

INSTRUCTION, FORD VAN SIDE DOOR KIT (WL) P/N 266996-01

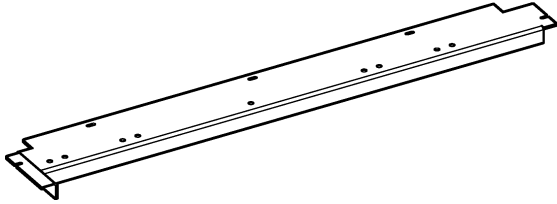

SIDE DOOR BRACKET
P/N 267057-01
QTY. 1

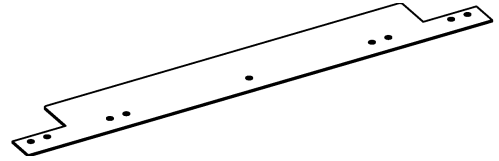

THRESHOLD SUPPORT PLATE
P/N 267059-01
QTY. 2

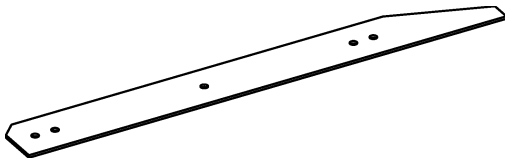

STEP SUPPORT PLATE
P/N 267058-01
QTY. 1

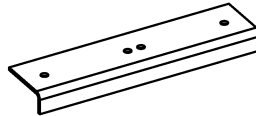

SUPPORT PLATES
P/N 267060-01
QTY. 2



ROUND TUBE 3/4" O.D.
P/N 092031-10
QTY. 3

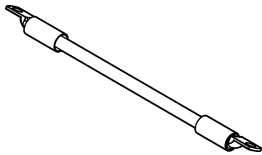

CABLE ASSY, 2 GA,
36" LG.
P/N 251871-11
QTY. 1

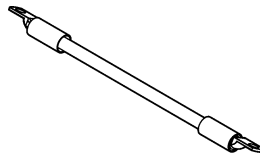

CABLE ASSY, 2 GA,
24" LG.
P/N 251871-12
QTY. 1

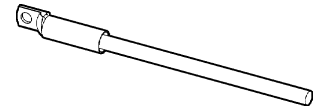

CABLE ASSY, 2 GA,
15' LG.
P/N 266999-03
QTY. 1

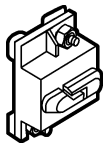

CIRCUIT BREAKER, 90 AMP
P/N 905037
QTY. 1

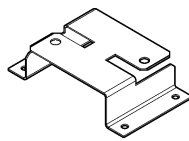

BRACKET, 90 AMP
CIRCUIT BREAKER
P/N 265151
QTY. 1



COPPER LUG, 2 GA,
5/16" STUD
P/N 906497-02
QTY. 1



HEATSHRINK TUBING,
5/8" I.D. X 2" LG.
P/N 253316-01
QTY. 1

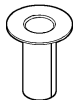

GROMMET, 1"
P/N 267066-01
QTY. 1

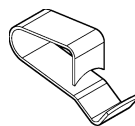

FRAME CLIP
P/N 050079
QTY. 6



PLASTIC TIE, 7"
P/N 205780
QTY. 6



**CARRIAGE SCREW,
SQUARE NECK
3/8"-16 X 2" LG.
GRADE 5, ZINC PLATED
P/N 900063-6
QTY. 7**



**CARRIAGE SCREW,
SQUARE NECK
3/8"-16 X 8" LG.
GRADE 5, ZINC PLATED
P/N 900063-17
QTY. 3**



**CAP SCREW, HEX
HEAD, 3/8"-16 X 1" LG.
GRADE 8, ZINC PLATED
P/N 900014-4
QTY. 1**

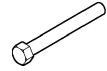

**CAP SCREW, HEX
HEAD, 1/4"-20 X 1" LG.
GRADE 8, ZINC PLATED
P/N 900004-3
QTY. 2**



**FLAT HEAD SOCKET SCREW
1/4"-20 X 1" LG.
P/N 900044-6
QTY. 3**



**SCREW, #12
SELF DRILLING, HEX
WASHER HEAD
P/N 900045-1
QTY. 6**



**SCREW, HEX SELF TAP # 14
WASHER SLOT, 1-1/4" LG.
P/N 900067-05
QTY. 2**



**LOCK NUT, 3/8"-16
GRADE 8, ZINC PLATED
P/N 901002
QTY. 10**



**LOCK NUT, 1/4"-20
GRADE 8, ZINC PLATED
P/N 901000
QTY. 5**



**HEX NUT, 3/8"-16
GRADE 8, ZINC PLATED
P/N 901011-5
QTY. 1**



**FLAT WASHER, 1/4"
P/N 902000-1
QTY. 5**



**LOCK WASHER, 1/4"
P/N 902011-2
QTY. 3**



**LOCK WASHER, 3/8"
P/N 902005-1
QTY. 11**



**FLAT WASHER (SHIM)
3/8" X 1/16" THICK
P/N 902001-2
QTY. 8**



**FLAT WASHER (SHIM)
3/8" X 1/8" THICK
P/N 902001-1
QTY. 20**



**FLAT WASHER, 7/16",
ZINC PLATED
P/N 906480-01
QTY. 4**

MOUNTING THE LIFT

NOTE: Lift installation is not complete until the following instructions and all the instructions in the Installation Manual are completed. See **MP-04-01** for the **WL7**, **MP-05-10** for the **WL7A**, and **MP-06-01** for the **WL7-vers. B**. The following steps are the instructions for bolting the Lift to a Bus floor with the correct screws, nuts, washers, and under-vehicle supports.

NOTE: **MAXON** recommends using all 10 Carriage Screws or Cap Screws (Kit items) to bolt Liftgate to Vehicle. At least 8 Carriage Screws or Cap Screws and use of holes 1, 2, 3, 4 & 9 are required for correct installation. Also, the front 3 holes should be selected to give a symmetrical bolt pattern (i.e. holes 5,10, & 8 or holes 6,10, & 7).

1. Drill the remaining holes marked according to instructions in the Installation Manual (i.e. holes 5, 10, & 8 or holes 6,10, & 7). See **MP-04-01** for the **WL7**, **MP-05-10** for the **WL7A**, and **MP-06-01** for the **WL7-vers. B**. Before drilling holes in the vehicle floor, make sure no wires and fluid lines are too close to hole locations.

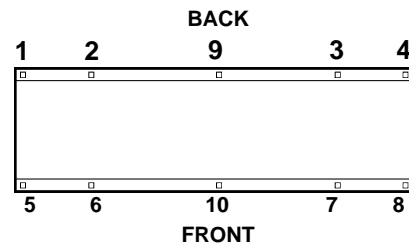

BASE PLATE BOLT HOLE PATTERN
FIG. 3-1

NOTE: Vehicle floor must meet the requirements shown at the beginning of the **VEHICLE REQUIREMENTS** section of the Installation Manual. See **MP-04-01** for the **WL7**, **MP-05-10** for the **WL7A**, and **MP-06-01** for the **WL7-vers. B**. If possible, use vehicle subframe members to help support Lift (**FIG. 3-2A**).

2. Insert 3/8"-16 Carriage Screws through the holes in the Base Plate (**FIG. 3-2B**), vehicle floor, and supports to hold the Lift in position. Use the 8" long or 2" long Carriage Screws as required.

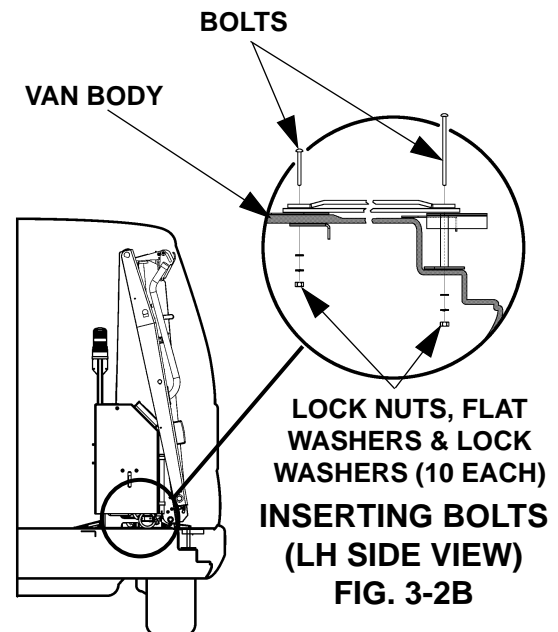

LIFT MOUNTED IN FORD VAN
(SIDE DOOR MODEL SHOWN)
FIG. 3-2A

3. Bolt the Base Plate (part of the Lift) to the Threshold Support Plates, Side Door Bracket, Round Tubes, Step Support Plate, and Support Plates (under vehicle) as shown in (FIG. 4-1). Under the vehicle, use Spacer Plates to support the Lift in places where the bolts cannot be used with Support Plates.

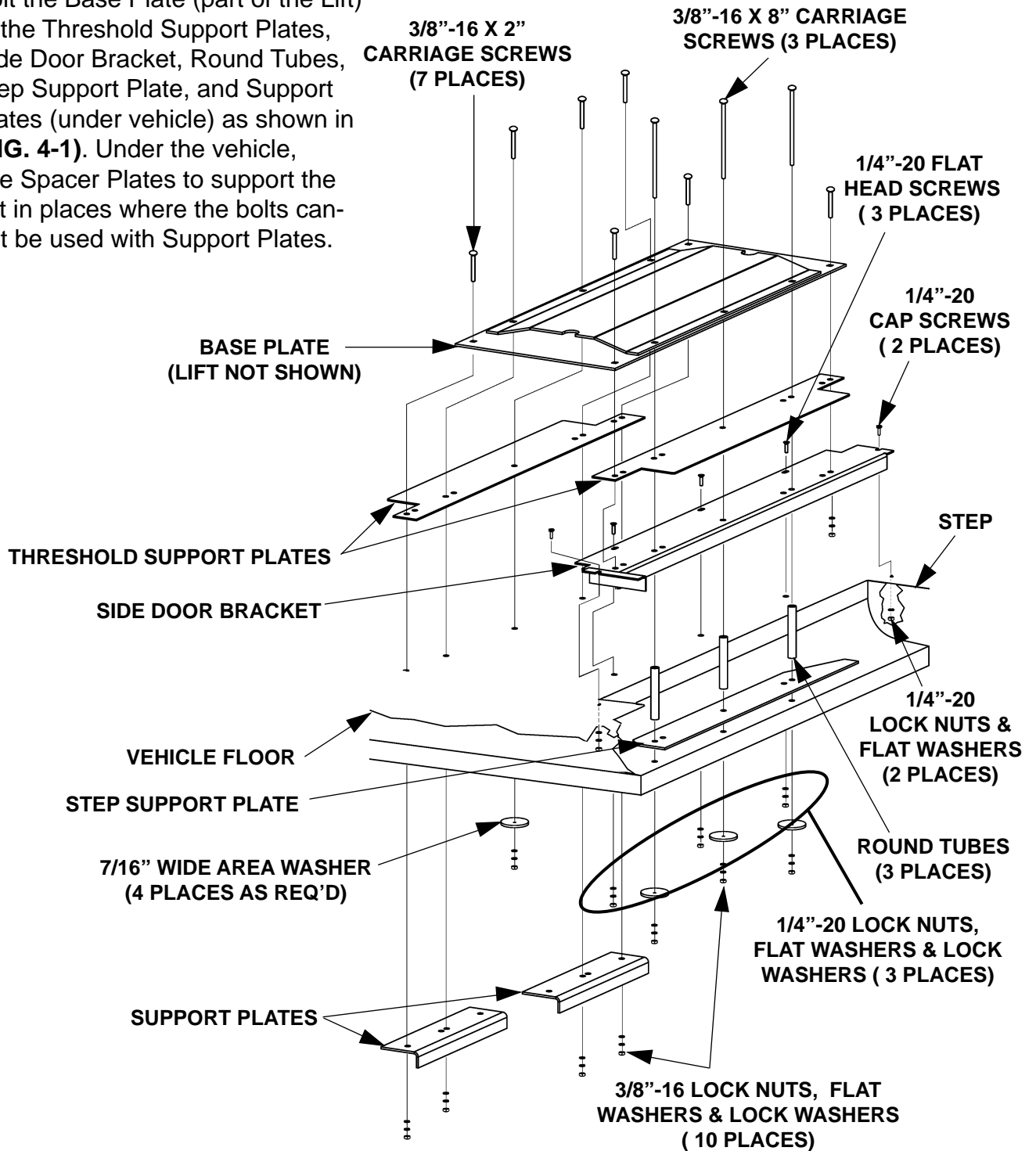

SECURING BASE PLATE WITH INSTALLATION KIT

FIG. 4-1

⚠ CAUTION

To prevent Lift base assembly from becoming warped, tighten attaching screws in the correct sequence indicated in the following NOTE. Warped base assembly can result in misaligned Lift traveling arms and cause Lift to operate incorrectly (uneven move-

4. Tighten each of the Carriage Screws or cap Screws and lock nuts in the correct sequence shown in **FIG. 5-1**. Start by tightening screw number 2. If a bolt hole is not used, skip over it in the tightening sequence. Torque each screw to **20 to 30 LBS.-FT.**

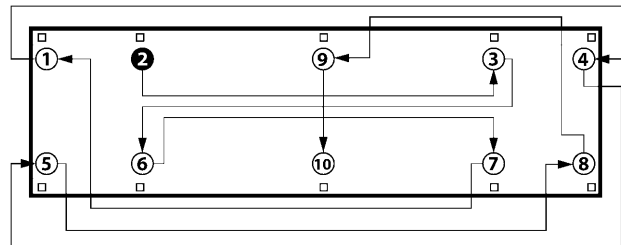

**BASE PLATE BOLT
TIGHTENING SEQUENCE
FIG. 5-1**

5. Check the Lift for correct alignment as follows. Measure angle between RH Tower and Base Plate (**FIG. 5-2**). Repeat for LH Tower. Both the RH and LH Towers must be approximately 90 degree angle to Base Plate (**FIG. 5-2**). If either Tower is not at the 90 degree angle, place shim washer (Kit item) on the affected side of the Base Plate, between Base Plate and Vehicle Floor. Use the existing screws to secure the shim. Retighten screws according to step 4 and the preceding **NOTE**.

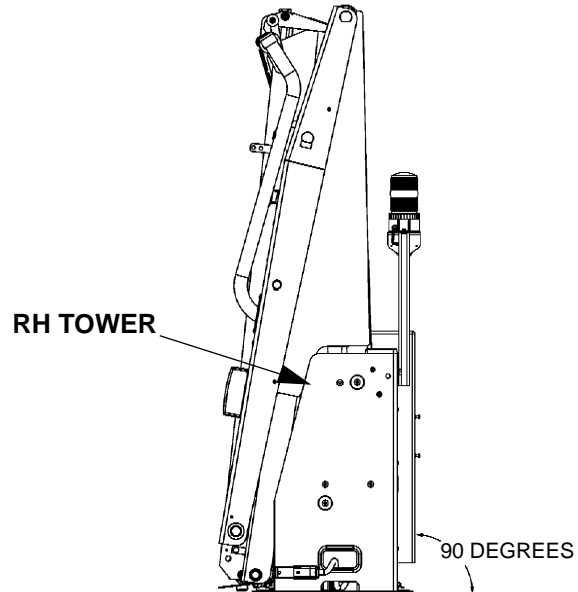

**CORRECT ALIGNMENT
(WL7-vers. B SHOWN)
FIG. 5-2**

6. Check stowed Lift for correct clearance (**FIG. 6-1**) between each Vertical Arm and Platform. If there is too much (**FIG. 6-2**) or too little clearance (**FIG. 6-3**), shim the Base Plate screws where shown in the applicable figure. Place shim washers (Kit item) between Base Plate and Vehicle floor. Use the existing screws to secure shim. Retighten screws according to step 4 and the preceding **NOTE**.

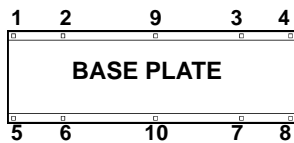
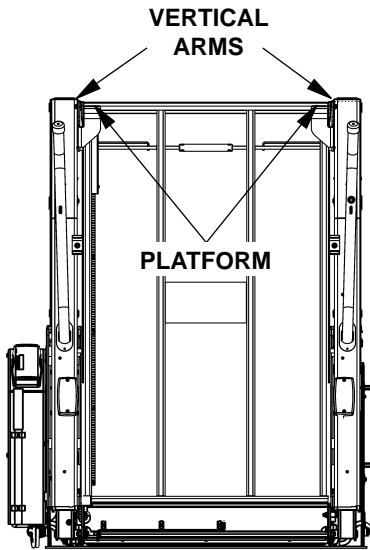

NO SHIMMING REQUIRED

CORRECT CLEARANCE
(WL7-vers. B SHOWN)
FIG. 6-1

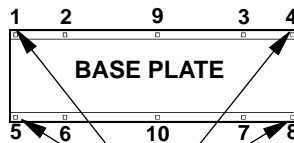
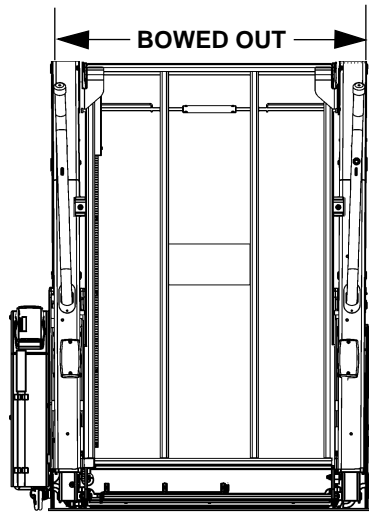

SHIM HERE

TOO MUCH CLEARANCE
(WL7-vers. B SHOWN)
FIG. 6-2

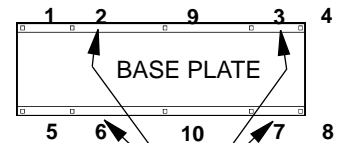
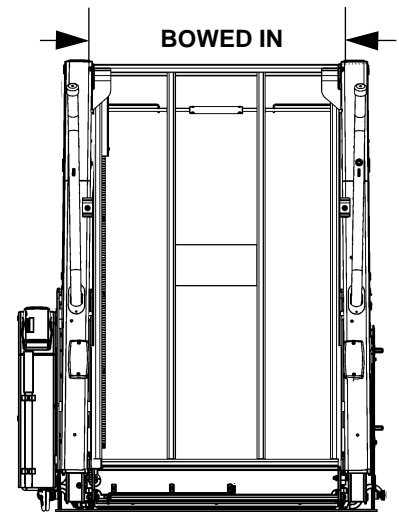

SHIM HERE

TOO LITTLE CLEARANCE
(WL7-vers. B SHOWN)
FIG. 6-3

7. For WL7 only, rotate the Threshold Plate into correct position above the Base Plate (**FIG. 6-4**).

8. Refer to the Installation Manual to finish the checks, adjustments and **COMPLETED LIFT INSTALLATION CHECKLIST**. See **MP-04-01** for the WL7, **MP-05-10** for the WL7A, and **MP-06-01** for the WL7-vers. B.

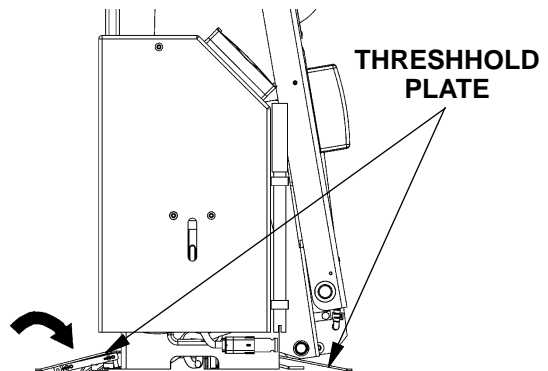

THRESHOLD PLATE SHOWN IN POSITION FOR OPERATING LIFT
(WL7-vers. B SHOWN)
FIG. 6-4