

# WL7-vers. B

# MAXON<sup>®</sup> MOBILITY™

## OPERATING INSTRUCTIONS FOR WHEELCHAIR LIFT MODEL NO. WL7-vers. B

### DOT-Public Use Lift

“DOT-Public Use Lift” verifies that this platform lift meets the “public use lift” requirements of FMVSS No. 403. This lift may be installed on all vehicles appropriate for the size and weight of the lift, but must be installed on buses, school buses, and multi-purpose passenger vehicles other than motor homes with a gross vehicle weight rating (GVWR) that exceeds 4,536 kg (10,000 lb).

**PATENTS PENDING**

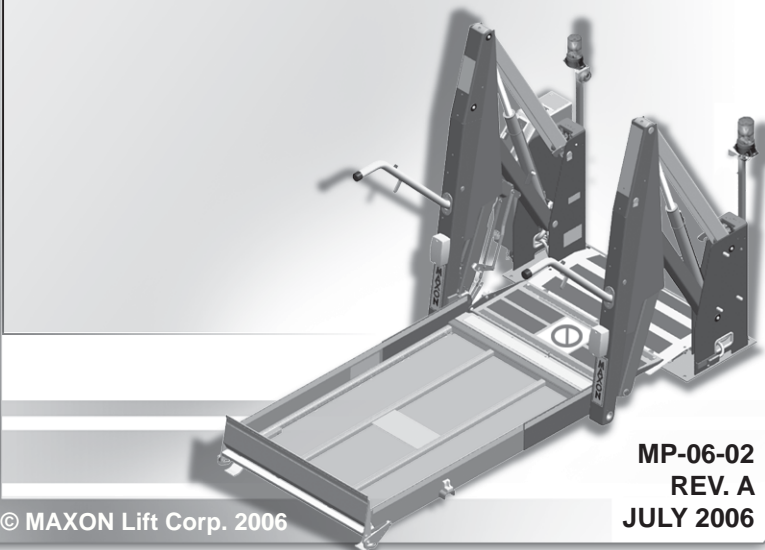

© MAXON Lift Corp. 2006

MP-06-02  
REV. A  
JULY 2006



# TABLE OF CONTENTS

<b>INTRODUCTION</b> .....	<b>4</b>
<b>SAFETY SUMMARY</b> .....	<b>4</b>
<b>DAILY PRE-OPERATION &amp; OPERATION CHECKLIST</b> .....	<b>6</b>
<b>MAINTENANCE SCHEDULE</b> .....	<b>8</b>
LIFT COMPONENTS & TERMINOLOGY.....	10
DECALS AND DECAL PLACEMENT .....	12
ANTI-SLIP & SAFETY STRIPING .....	15
<b>OPERATING INSTRUCTIONS</b> .....	<b>18</b>
ENTER VEHICLE .....	18
EXIT VEHICLE .....	21
STOW LIFT .....	23
<b>MANUAL PUMP OPERATION</b> .....	<b>24</b>
LOADING & UNLOADING OCCUPANT.....	24

# INTRODUCTION

This manual contains safety information and operating instructions for the Maxon Wheelchair and Standing Occupant Lift. Read and understand the **WARNINGS**, **SAFETY CONSIDERATIONS**, and operating instructions in this manual, before operating the Lift.

## SAFETY SUMMARY

### **WARNING**

1. This Wheelchair Lift is intended for Commercial Use and to be operated by an Attendant. Do Not attempt to ride Lift without the assistance of an Attendant.
2. Incorrect operation of this Lift can result in serious personal injury. Comply with the **WARNINGS** and Lift operating instructions in this manual. Do not allow untrained persons to operate the Lift. If you need to replace an Operator's Manual, additional copies are available from:

**MAXON Lift Corp.**  
**11921 Slauson Ave**  
**Santa Fe Springs, CA 90670**  
**(800) 227-4116**

3. Do not exceed rated load capacity of Lift which is **800 lbs. (364 kg)**.
4. Do not allow any part of your body, or the Lift occupant's body, to be placed under, within, or around any portion of the moving Lift or its mechanisms, or in a position that would trap them between the platform and the ground (or vehicle) when Lift is operated.
5. Consider the safety and location of bystanders and location of nearby objects when operating the Lift. Stand to one side of platform while operating the Lift. Be certain that the area the Lift will move through during operation is clear of all obstacles.
6. If possible, park the vehicle on level ground. Always set the vehicle emergency brake before operating the Lift. If the Lift is operated without setting the emergency brake, it may create a hazard for occupant and attendant.

7. Comply with all attached instruction decals and warning decals.
8. Above all, USE GOOD COMMON SENSE when operating this Lift.
9. Do not move vehicle when the wheelchair door is open.
10. MAXON recommends positioning the wheelchair so most of the weight is by the Inboard Rollstop (see illustration below).

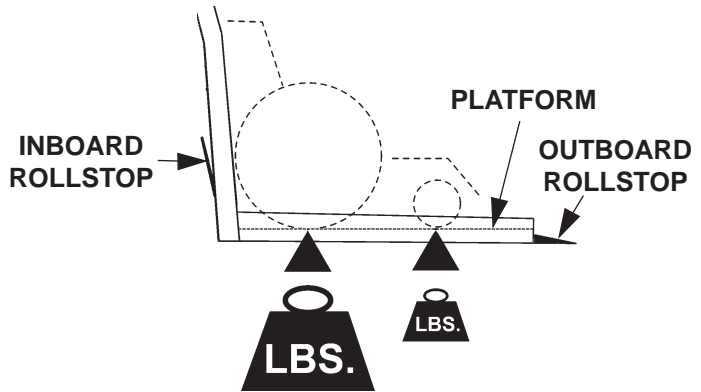

11. An ambulatory (standing) occupant may face outboard or inboard. If possible, position ambulatory occupant on the Lift, facing the direction of travel (face vehicle when entering or face away when exiting), and holding on the handrails.

# DAILY PRE-OPERATION & OPERATION CHECKLIST

**NOTE: PRE-OPERATION and OPERATION CHECKS should be performed by the Lift Operator.**

## PRE-OPERATION CHECKS

**Park vehicle on level ground, shift vehicle transmission to PARK, and set vehicle emergency brake before doing the following checks..**

- Visually check Lift for bent or broken parts, or for hydraulic fluid around base. Have hydraulic fluid leaks, and the fluid level in reservoir, checked by a qualified technician.
- Check for hydraulic fluid leaking from cylinders. Lift may be operated if cylinders are “weeping” a light film of hydraulic fluid. If hydraulic fluid drips from either cylinder, have it checked by a qualified technician.
- Check that all Decals are in place, undamaged, and legible (see **DECALS** pages).
- Check that all anti-slip and safety striping is in place (see **ANTI-SLIP & SAFETY STRIPING** pages).
- If the Lift is dirty, clean it.
- Make sure the ON/OFF switch on the Pump Cover is turned ON. If indicator on the switch is illuminated, Lift has power to operate.**

**NOTE: If any of the PRE-OPERATION CHECKS have incorrect indications, do not operate the Lift until repairs are performed by a qualified technician.**

## **OPERATION CHECKS**

**Operate the Lift through one full cycle to do the following checks.**

- Use Lift operating instructions in this manual to **UNFOLD**, **LOWER**, **RAISE**, and **FOLD** platform.
  
- Make sure the Lift responds properly to hand control switches.**
  
- Listen for unusual noises while the Lift operates.**
  
- Watch for uneven movement of the Lift arms, platform, and inboard and outboard rollstops.**

**NOTE: If any of the OPERATION CHECKS have incorrect indications, discontinue operating Lift until repairs are performed by a qualified technician.**

# MAINTENANCE SCHEDULE

**NOTE:** The Lift Controller counts the number of cycles & lifts over the lifetime of the Lift. One **CYCLE** is counted each time the Lift is unfolded from the stowed position to floor level, lowered to the ground, raised to floor level, and then stowed. One **LIFT** is counted each time the Lift is lowered from floor level to the ground, and raised back to floor level. Read the **LIFTS** and **CYCLES** counts from the Lift Controller display window periodically so you know when to do the maintenance checks listed below.

**NOTE:** Only a qualified technician should do the scheduled maintenance on this page and confirm compliance with **Federal Motor Vehicle Safety Standard 403**. For the compliance checks, refer to the **COMPLETED LIFT INSTALLATION CHECKLIST** in Installation Manual **MP-06-01**.

## EVERY 500 LIFTS

- Visually check the Lift for bent, broken, or worn out parts, and broken welds.
- Check the electrical wiring for worn insulation, and the terminals for corrosion and secure fit. Apply dielectric grease to connections if needed.
- Check for loose fasteners (nuts, bolts, screws & rivets). Also, check cotter pins, clevis pins, retaining ring pins & retaining rings for noticeable wear and damage.
- Check that all Decals are in place, undamaged, and legible (**see DECALS pages**).
- Check that all anti-slip and safety striping is in place and undamaged (**see ANTI-SLIP & SAFETY STRIPING pages**).
- Clean dust and debris from Outboard Switch & Ground Switch (magnetic switches on Platform). (**See ELECTRICAL COMPONENTS in the Maintenance Manual.**)

## EVERY 2500 CYCLES

- Replace both latch Solenoids P/N 266955-01
- Apply multi-use teflon spray lubricant to all springs on the Lift.

## EVERY 5000 LIFTS

- Replace both Platform light bulbs P/N 906475-01.

## EVERY 10000 LIFTS

- Check both Hydraulic Cylinders for leaks. If a film of hydraulic fluid is visible on cylinder seals Lift can still be operated. However, if fluid is dripping from the cylinders, replace them.



**THIS PAGE INTENTIONALLY LEFT BLANK**

# LIFT COMPONENTS & TERMINOLOGY

INBOARD

RIGHT

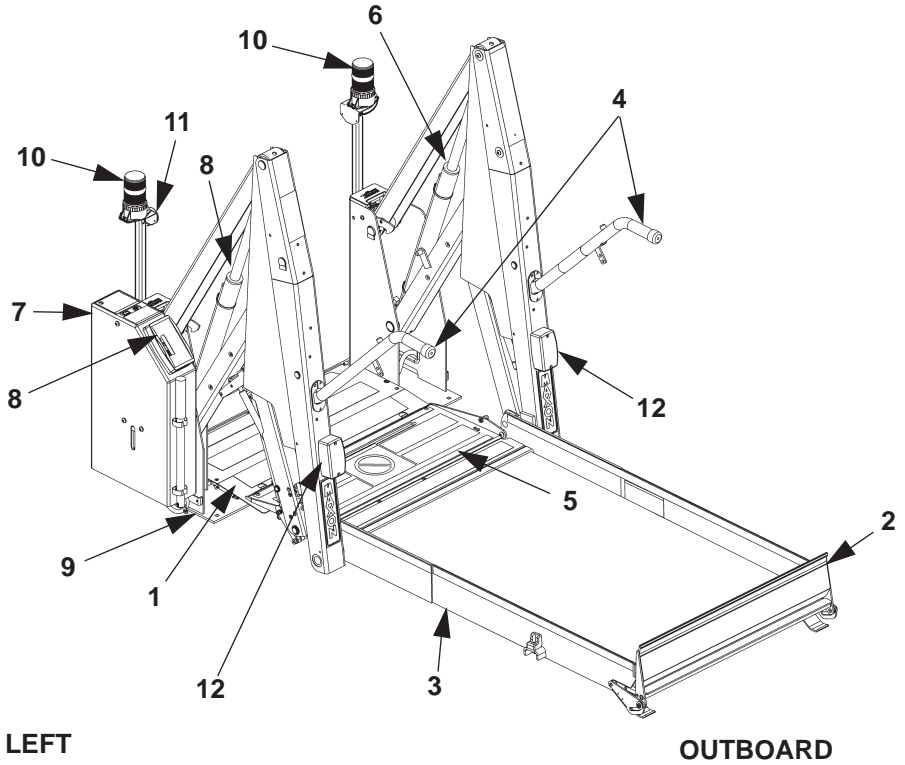

LIFT COMPONENTS (SEE TABLE 9-1)  
FIG. 10-1

<b>ITEM</b>	<b>NAME</b>	<b>DESCRIPTION</b>
1.	THRESHOLD PLATE	Component that bridges the entry way, through the Lift, into the vehicle. Detects if that portion of Lift is occupied during "UP/DOWN" operation between vehicle floor and the ground.
2.	OUTBOARD ROLLSTOP	Barrier to prevent the Wheelchair from rolling off of the Platform. Also provides entry/exit ramp for Platform on the ground.
3.	PLATFORM	Contains the Wheelchair and Occupant during "UP/DOWN" operation between vehicle floor and the ground.
4.	HANDRAILS	(Left/Right) Provides a hand hold for the Lift Occupant.
5.	INBOARD ROLLSTOP	Barrier to prevent the Wheelchair from rolling off inboard side of Platform. Also, provides bridge between Platform and Threshold.
6.	HYDRAULIC CYLINDER	(Left/Right) Telescoping steel tube and rod, pressurized by hydraulic fluid, that folds and unfolds the Lift and moves the Lift up and down.
7.	HYDRAULIC POWER UNIT (COVER IS SHOWN)	Contains motorized hydraulic pump, manually operated backup pump, fluid lines, and controls to operate the hydraulic cylinders.
8.	LIFT CONTROLLER	Electronic device that controls and monitors Lift operation and the interlock connection with the vehicle.
9.	BASE	Structure that secures Lift to the vehicle floor.
10.	THRESHOLD WARNING BEACON	Flashing red light indicates Threshold is occupied by a person or object when the Platform is below floor level. Also indicates Outboard Rollstop is open if Platform is at floor level.
11.	THRESHOLD WARNING ALARM	Audible alarm sounds when Threshold is occupied by a person or object when the Platform is below floor level. Also indicates Outboard Rollstop is open if Platform is at floor level.
12.	PLATFORM LIGHTS	Illuminates the Platform when ready to load at floor level and during "UP/DOWN" operation between vehicle floor and the ground.

**TABLE 11-1**

# DECALS AND DECAL PLACEMENT

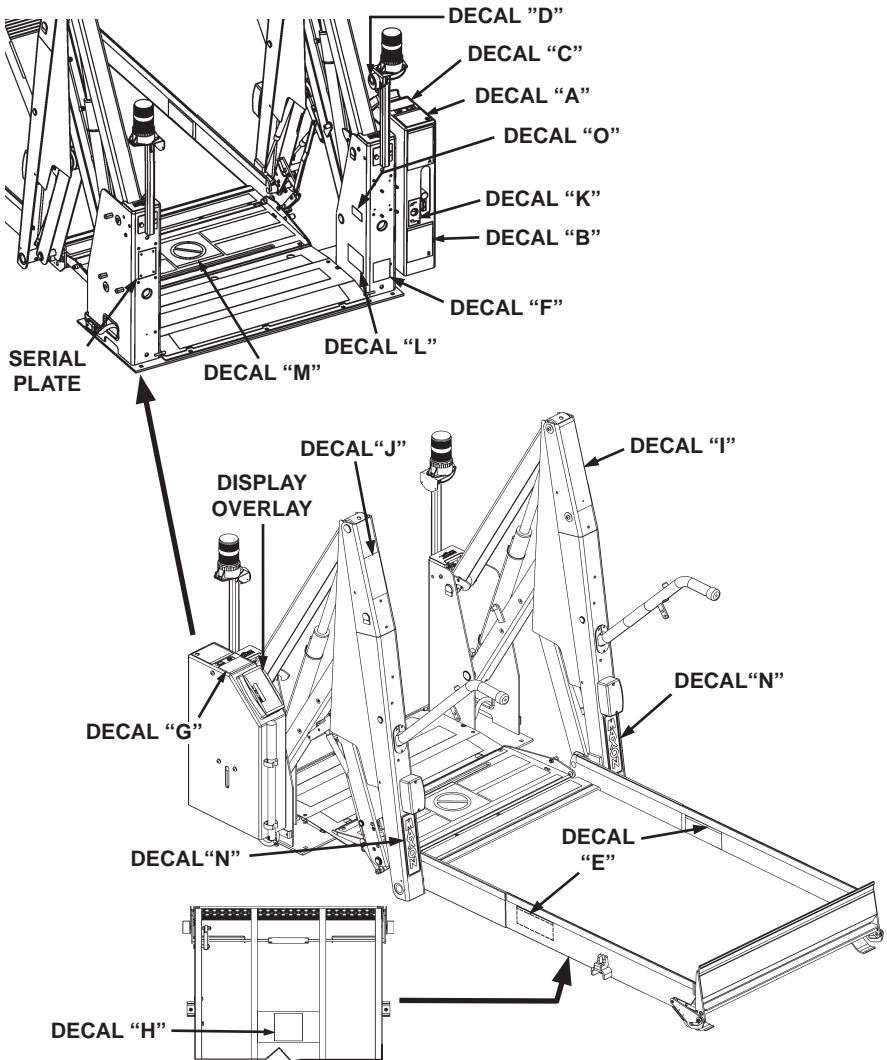

FIG. 12-1

All **WARNING**, **CAUTION**, and **OPERATION** decals provided with Wheelchair Lift must always be in place on the Lift and must always be legible. If decals are missing or illegible, get free replacement decals from:

**MAXON Lift Corp. - Customer Service**  
11921 Slauson Ave., Santa Fe Springs, CA 90670  
Phone: (800) 227-4116 FAX: (888) 771-7713  
E-mail: [cservice@maxonlift.com](mailto:cservice@maxonlift.com)

**BACKUP OPERATING INSTRUCTIONS FOR UNLOADING PASSENGERS DOT-PUBLIC USE LIFT** **A**

1. PUMP TO PRESSURIZE
2. RAISE LH & RH LATCHES
3. 1/4 - 1/2 TURN OPEN VALVE
4. UNFOLD
5. TIGHTEN CLOSE VALVE
6. LOAD OCCUPANT
7. 1/4 - 1/2 TURN OPEN VALVE
8. LOWER & UNLOAD OCCUPANT
9. TIGHTEN CLOSE VALVE

PIN 267620-01

**BACKUP OPERATING INSTRUCTIONS FOR LOADING PASSENGERS DOT-PUBLIC USE LIFT** **B**

1. LOAD OCCUPANT
2. TIGHTEN CLOSE VALVE
3. PUMP
4. RAISE & UNLOAD OCCUPANT
5. PUMP
6. STOW

PIN 267620-01

**OPERATING INSTRUCTIONS DOT-PUBLIC USE LIFT**

**UNFOLD LIFT:**

1. FULLY OPEN AND SECURE WHEELCHAIR DOOR(S).
2. MAKE SURE SEAT BELT IS FASTENED IF EQUIPPED.
3. PUSH FOLD SWITCH FOR 1-2 SECONDS.
4. PUSH UNFOLD SWITCH TO UNFOLD PLATFORM TO VEHICLE FLOOR LEVEL.

**LOAD PASSENGERS:**

1. PUSH DOWN SWITCH TO LOWER PLATFORM TO GROUND LEVEL.
2. UNFASTEN SEAT BELT IF EQUIPPED.
3. POSITION WHEELCHAIR IN THE CENTER OF PLATFORM AND LOCK WHEELCHAIR BRAKES.
4. FASTEN SEAT BELT IF EQUIPPED.
5. PUSH UP SWITCH TO RAISE PLATFORM TO VEHICLE FLOOR LEVEL.
6. RELEASE WHEELCHAIR BRAKES.
7. LOAD WHEELCHAIR IN VEHICLE.

**UNLOAD PASSENGERS:**

1. POSITION WHEELCHAIR IN THE CENTER OF PLATFORM AND LOCK WHEELCHAIR BRAKES.
2. MAKE SURE SEAT BELT IS FASTENED IF EQUIPPED.
3. PUSH DOWN SWITCH TO LOWER PLATFORM TO GROUND LEVEL.
4. UNFASTEN SEAT BELT IF EQUIPPED.
5. RELEASE WHEELCHAIR BRAKES
6. UNLOAD WHEELCHAIR FROM PLATFORM.

**STOW LIFT:**

**FROM VEHICLE FLOOR LEVEL**

1. MAKE SURE PLATFORM IS EMPTY AND SEAT BELT IS FASTENED IF EQUIPPED.
2. PUSH FOLD SWITCH UNTIL PLATFORM FOLDS COMPLETELY UNDER HYDRAULIC PRESSURE.

**FROM GROUND LEVEL**

1. MAKE SURE PLATFORM IS EMPTY AND SEAT BELT IS FASTENED IF EQUIPPED.
2. PUSH UP SWITCH TO RAISE PLATFORM TO VEHICLE FLOOR LEVEL.
3. PUSH FOLD SWITCH UNTIL PLATFORM FOLDS COMPLETELY UNDER HYDRAULIC PRESSURE.

**I** PIN 267620-01

**CAUTION** **C**

THRESHOLD PLATE  
ROLLSTOP

Prevent injury & damage to lift. Make sure Rollstop rests on top of Threshold Plate before loading & unloading passengers. Raise or lower Platform until Rollstop rests correctly on Threshold Plate.

PIN 267620-01

**Chassis Electrical Ground**

The surface finish of this lift is powder coat paint. To insure a proper electrical ground to the vehicle chassis remove the paint from the area around the chassis grounding strap mounting bolt hole by grinding or sanding the surface to expose bare metal. Also, remove any undercoating from the surface of the vehicle chassis where the strap will be fastened.

**F** PIN 267620-01



**STANDING POSITION ON PLATFORM**

Position a standing passenger in center of platform between handrails, gripping handrails, and facing direction of travel.

**E** PIN 267620-01

**G**

To automatically maintain hydraulic pressure when lift is stowed, keep power switch **ON**.

PIN 267620-01

**BACKUP OPERATION**

- TO UNFOLD, OPEN VALVE SLOWLY
- TO LOWER, OPEN VALVE

OPEN  
CLOSE

CLOSE VALVE TIGHTLY

- TO STOP UNFOLDING
- TO STOP LOWERING
- TO RAISE & FOLD

**K** PIN 267620-01

**WARNING** **H**

To avoid possible injury, stand clear of the Lift Platform.

PIN 267620-01

The MAXON Lift Corp. certifies that this wheelchair lift conforms to all applicable requirements of the Americans w/Disabilities Act of 1990, current National School Transportation Specifications and Procedures, and the California Code of Regulations requirements in effect on the date of manufacture.

**L** PIN 267620-01

**WARNING**

THIS WHEELCHAIR LIFT MUST BE OPERATED BY AN ATTENDANT. DO NOT ATTEMPT TO RIDE LIFT WITHOUT THE ASSISTANCE OF AN ATTENDANT. IMPROPER OPERATION OF THIS LIFT CAN RESULT IN SERIOUS PERSONAL INJURY. DO NOT OPERATE UNLESS YOU HAVE BEEN PROPERLY INSTRUCTED AND HAVE READ, AND ARE FAMILIAR WITH, THE OPERATING INSTRUCTIONS AND SAFETY SUMMARY CONTAINED IN THE OPERATOR'S MANUAL. IF YOU DO NOT HAVE A COPY OF THE OPERATOR'S MANUAL, ADDITIONAL COPIES ARE AVAILABLE FROM:

MAXON LIFT CORP.  
1152 SLAGSON AVE.  
SANTA FE SPRINGS, CA 90670  
(800) 227-4116  
WWW.MAXONMOBILITY.COM

DO NOT EXCEED RATED LOAD CAPACITY OF LIFT WHICH IS:

**800 lbs. (364 kg)**

**J** PIN 267620-01

**DOT-Public Use Lift** **O**

PIN 267620-01

**DECAL SET P/N 267620-01**  
**FIG. 13-1**

# DECALS AND DECAL PLACEMENT - Continued

The MAXON Lift Corp. certifies that this wheelchair lift conforms to all applicable requirements of the Americans w/Disabilities Act of 1990, current National School Transportation Specifications and Procedures, and the California Code of Regulations requirements in effect on the date of manufacture.

**L**

P/N 267620-01

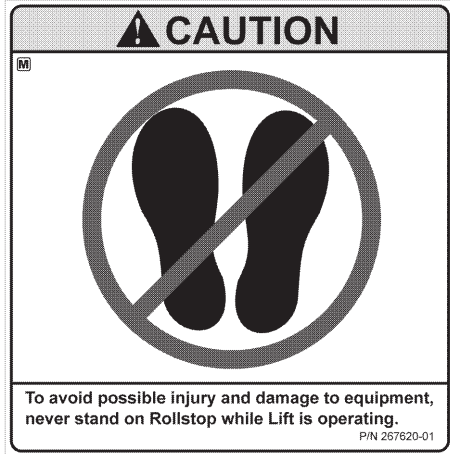

**DECAL SET P/N 267620-01  
FIG. 14-1**

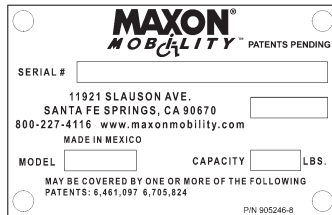

**SERIAL PLATE  
P/N 905246-8  
FIG. 14-2**



**DECAL-OVERLAY  
P/N 2667630-01  
FIG. 14-3**

# ANTI-SLIP & SAFETY STRIPING (30" WIDE PLATFORM)

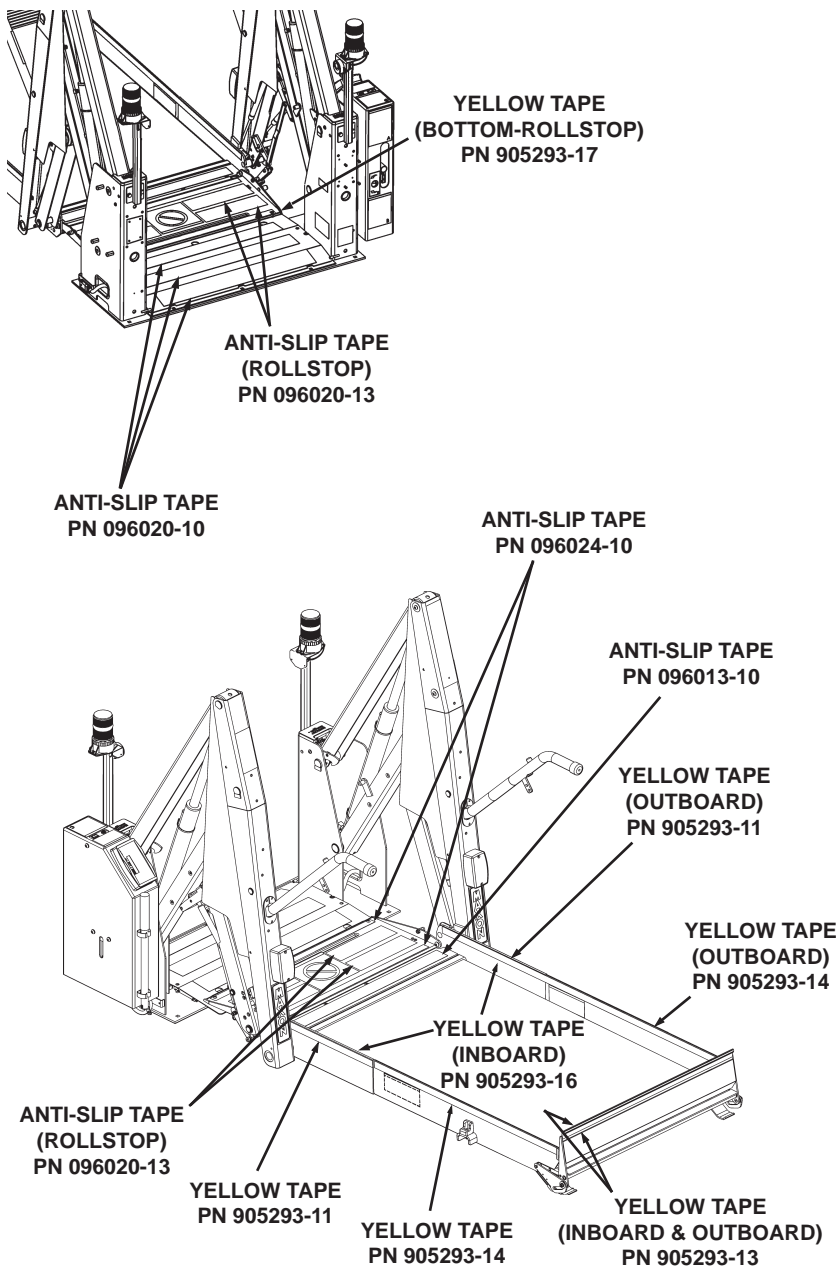

**FIG. 15-1**

# ANTI-SLIP & SAFETY STRIPING - Continued (33" WIDE PLATFORM)

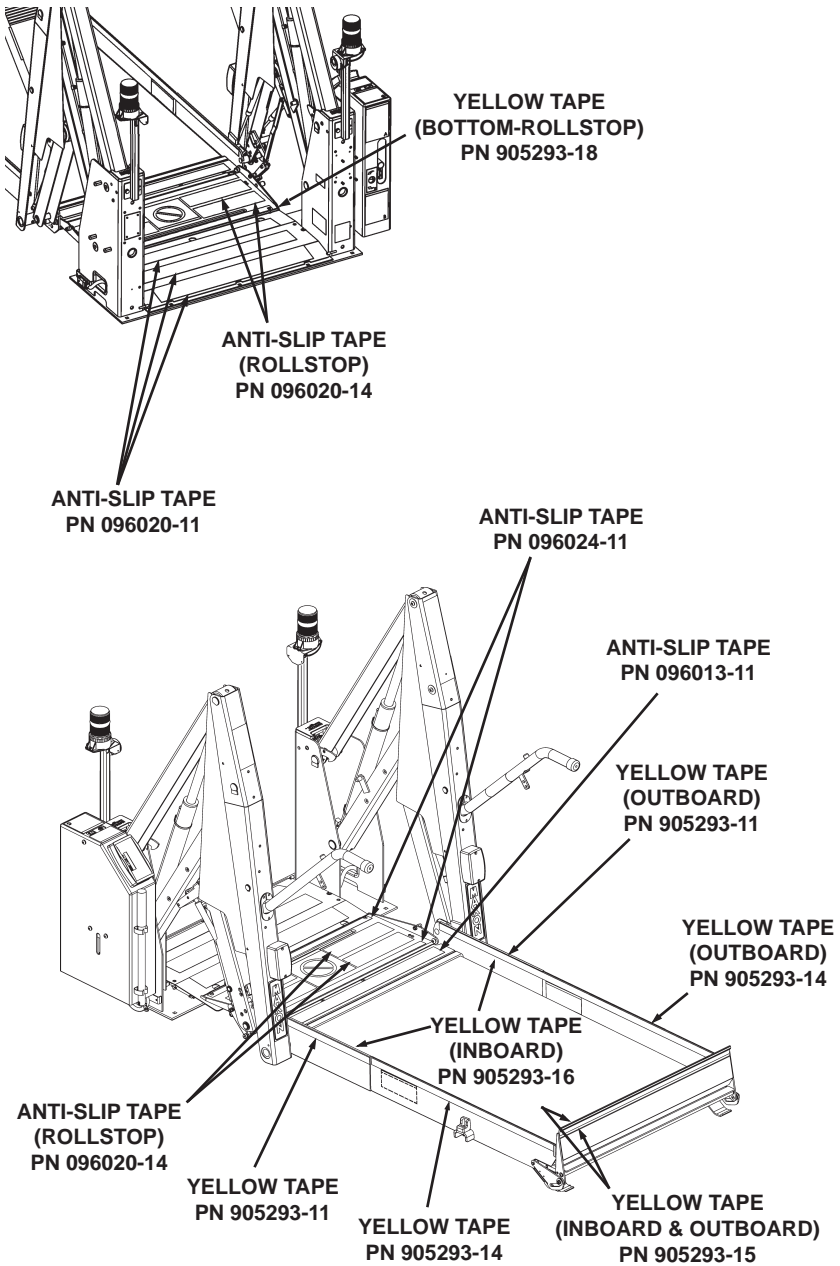

FIG. 16-1



# (34" WIDE PLATFORM)

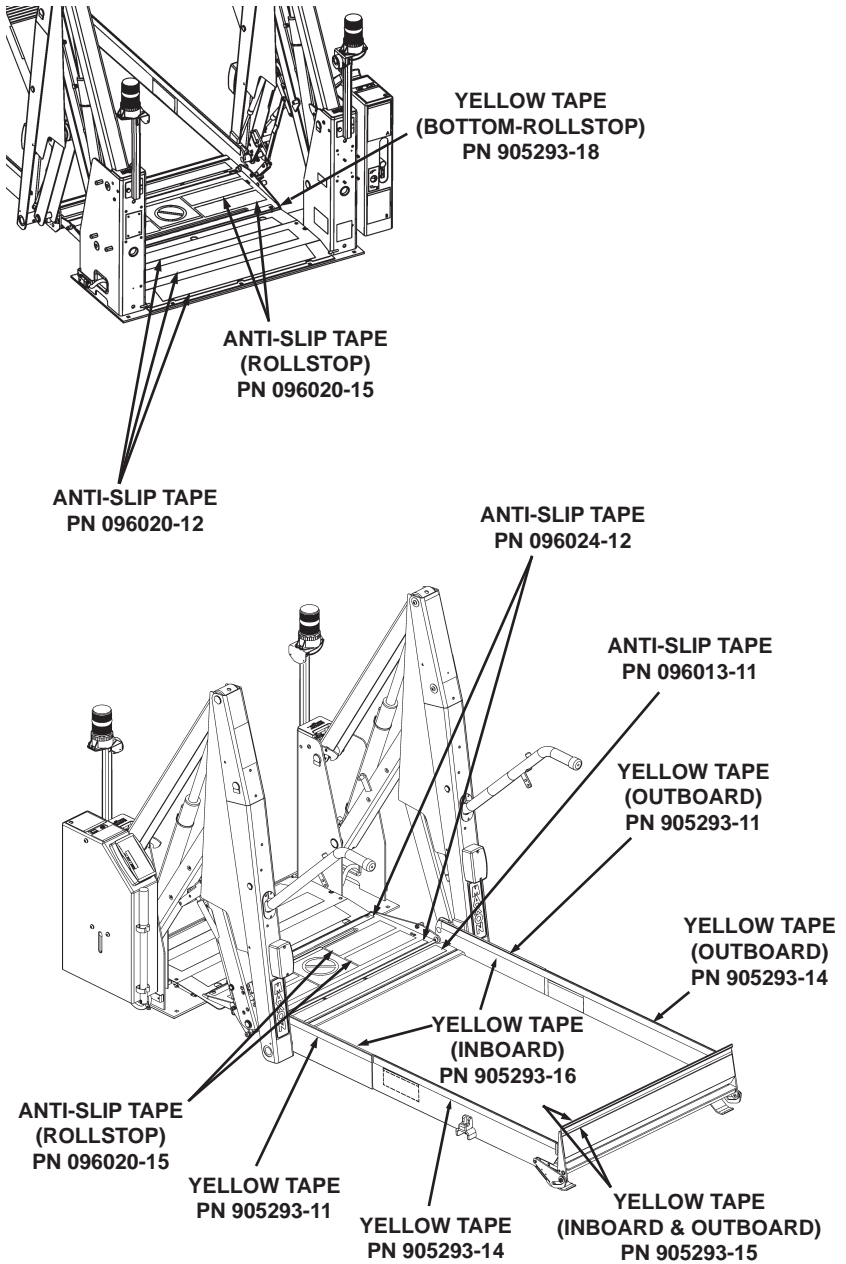

FIG. 17-1

# OPERATING INSTRUCTIONS

## ENTER VEHICLE

**NOTE:** If equipped, Seat Belt must be fastened for Lift to operate.

1. Fully open and secure Wheel-chair Lift access door(s) on the vehicle.

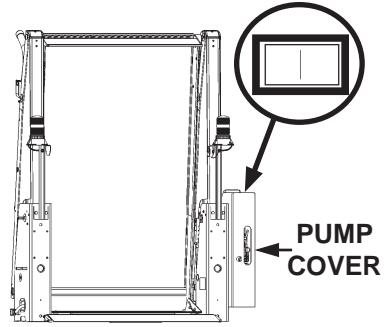

**POWER SWITCH  
(LH PUMP SHOWN)  
FIG. 18-1**

2. Apply power to the Lift by turning **ON** switch on the Pump Cover (**FIG. 18-2**). The switch is illuminated when turned **ON**.

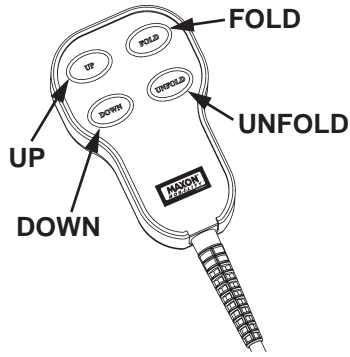

**HAND CONTROL  
FIG. 18-2**

3. Push the **UNFOLD** switch on HAND CONTROL (**FIG. 18-2**) to unfold PLATFORM to horizontal position (**FIG. 18-3**).

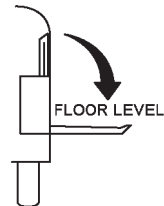

**UNFOLD PLATFORM  
FIG. 18-3**

4. Push the **DOWN** switch on **HAND CONTROL (FIG. 17-1)** to lower **PLATFORM** to ground level (**FIG. 19-1**).

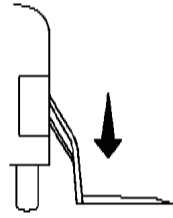

**LOWER PLATFORM  
TO GROUND  
FIG. 19-1**

5. If equipped, unfasten **SEAT BELT (FIG. 19-2)**. Place on hanger (**FIG. 19-3**).

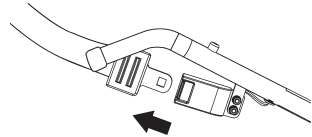

**UNFASTENING SEAT BELT  
(RH HANDRAIL SHOWN)  
FIG. 19-2**

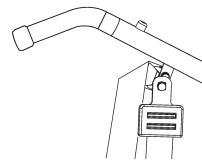

**SEAT BELT ON HANGER  
(LH HANDRAIL SHOWN)  
FIG. 19-3**

6. Position wheelchair or ambulatory occupant on the center of **PLATFORM (FIG. 19-4)**. **SET WHEELCHAIR BRAKES** or **SWITCH OFF POWERED WHEELCHAIR.**

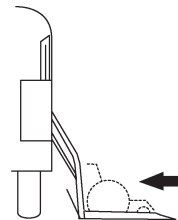

**POSITIONING OCCUPANT  
ON PLATFORM AT  
GROUND LEVEL  
FIG. 19-4**

# OPERATING INSTRUCTIONS - Continued

7. If equipped, fasten SEAT BELT (FIG. 20-1).

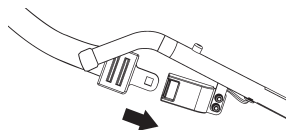

**FASTENING SEAT BELT  
(RH HANDRAIL SHOWN)  
FIG. 20-1**

8. Push the **UP** switch on HAND CONTROL (FIG. 20-2) to raise PLATFORM to vehicle floor level (FIG. 20-3).

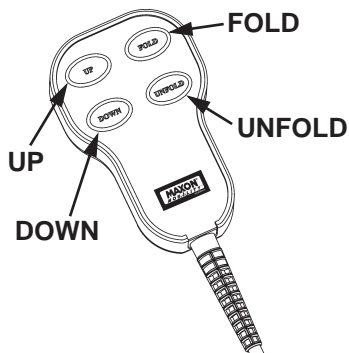

**HAND CONTROL  
FIG. 20-2**

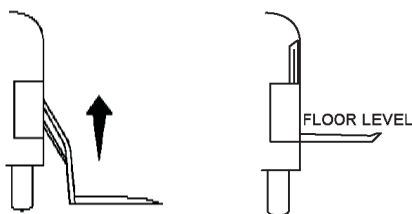

**RAISING LIFT UP TO VEHICLE FLOOR LEVEL  
FIG. 20-3**

9. **RELEASE WHEELCHAIR BRAKES** or **SWITCH ON POWERED WHEELCHAIR.**  
Move wheelchair or ambulatory occupant inside the vehicle.

## EXIT VEHICLE

1. Fully open and secure Wheelchair Lift access door(s) on the vehicle.
2. Push the **UNFOLD** switch on **HAND CONTROL (FIG. 20-2)** to unfold PLATFORM to horizontal position (**FIG. 21-1**).
3. If equipped, make sure **SEAT BELT** is fastened (**FIG. 21-2**).



**UNFOLD PLATFORM**  
**FIG. 21-1**

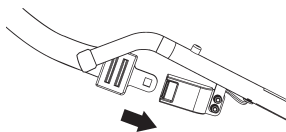

**FASTENING SEAT BELT**  
**(RH HANDRAIL SHOWN)**  
**FIG. 21-2**

4. Position wheelchair or ambulatory occupant on the center of platform (**FIG. 21-3**).  
**SET WHEELCHAIR BRAKES OR SWITCH OFF POWERED WHEELCHAIR.**

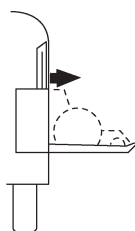

**POSITIONING OCCUPANT ON**  
**PLATFORM AT FLOOR LEVEL**  
**FIG. 21-3**

5. Push the **DOWN** switch on hand control (**FIG. 20-2**) to lower PLATFORM to ground level (**FIG. 21-4**).

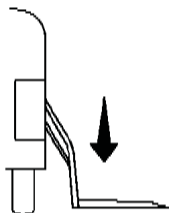

**LOWERING PLATFORM**  
**TO GROUND**  
**FIG. 21-4**

# OPERATING INSTRUCTIONS - Continued

6. If equipped, unfasten SEAT BELT (**FIG. 22-1**). Place on hanger (**FIG. 22-2**).

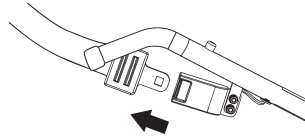

**UNFASTENING SEAT BELT  
(RH HANDRAIL SHOWN)  
FIG. 22-1**

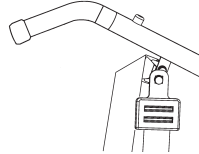

**SEAT BELT ON HANGER  
(LH HANDRAIL SHOWN)  
FIG. 22-2**

**7. RELEASE WHEELCHAIR BRAKES or SWITCH ON POWERED WHEELCHAIR.**

Move wheelchair or ambulatory occupant into the passenger unloading zone.

## STOW LIFT

1. If equipped, fasten SEAT BELT (FIG. 23-1).

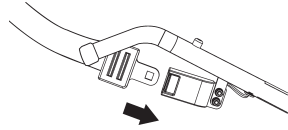

**FASTENING SEAT BELT  
(RH HANDRAIL SHOWN)  
FIG. 23-1**

2. Push the **UP** switch on HAND CONTROL (FIG. 23-2) to raise PLATFORM to vehicle floor level (FIG. 23-3).

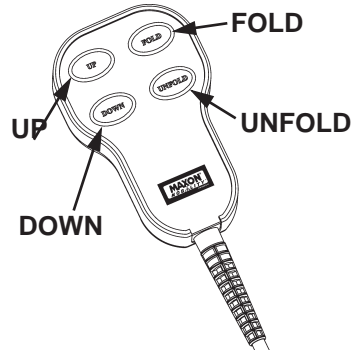

**HAND CONTROL  
FIG. 23-2**

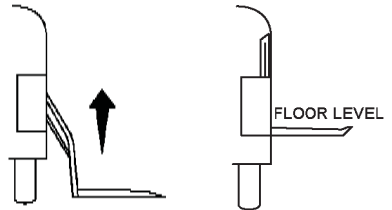

**RAISING LIFT TO VEHICLE  
FLOOR LEVEL  
FIG. 23-3**

3. Push the **FOLD** switch on HAND CONTROL (FIG. 23-2) to fold PLATFORM (FIG. 23-4). Fold operation will stop automatically when completed.

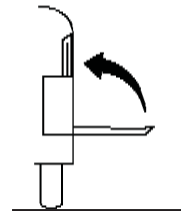

**FOLDING PLATFORM  
UP INTO VEHICLE  
FIG. 23-4**

# OPERATING INSTRUCTIONS - Continued

## MANUAL PUMP OPERATION

### LOADING & UNLOADING OCCUPANT

1. Reposition latches to manually unfold the Lift as follows. Raise latch off anchor pin (**FIG. 24-1A**) on LH side of Lift. Position the standoff to hold latch in place above the anchor pin (**FIG. 24-1B**). Repeat for latch on RH side of Lift.

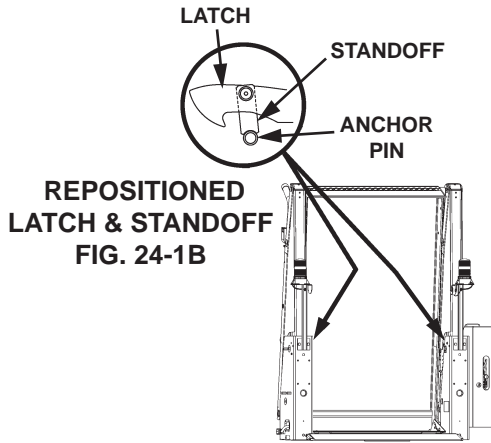

**REPOSITIONED  
LATCH & STANDOFF  
FIG. 24-1B**

**LIFT - BACK VIEW  
FIG. 24-1A**

2. Remove the MANUAL BACK-UP HANDLE from clips on the Pump Cover (**FIG. 24-2**).

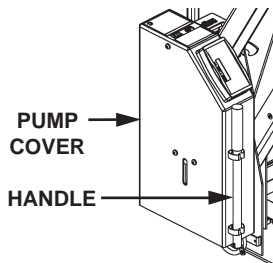

**MANUAL BACKUP HANDLE  
(LH PUMP SHOWN)  
FIG. 24-2**



3. Unfold the PLATFORM as follows. Open release valve on Manual Pump by turning MANUAL BACKUP HANDLE counter-clockwise (**FIG. 25-1**). Start with 1/4 turn and slowly increase to 1/2 turn counter-clockwise.

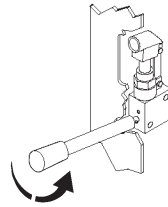

1/4 - 1/2 TURN  
**OPEN RELEASE VALVE**  
**FIG. 25-1**

4. Observe the PLATFORM unfolding to horizontal position at vehicle floor level (**FIG. 25-2**).



**UNFOLD PLATFORM**  
**FIG. 25-2**

5. When the PLATFORM reaches floor level, close release valve on Manual Pump by turning MANUAL BACKUP HANDLE clockwise until tight (**FIG. 25-3**).

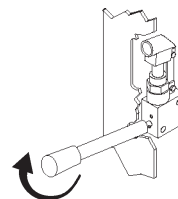

TIGHTEN  
**CLOSE RELEASE VALVE**  
**FIG. 25-3**

## MANUAL PUMP OPERATION - Continued

6. Ensure OUTBOARD ROLLSTOP is raised all the way (FIG. 26-1).

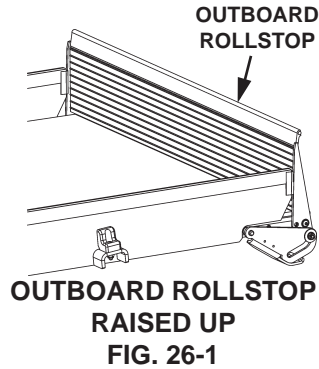

7. If equipped, make sure SEAT BELT is fastened (FIG. 26-2).



**NOTE:** If there are no occupants to unload from vehicle, skip step 8.

8. Position wheelchair or ambulatory occupant on the center of Platform (FIG. 26-3).  
**SET WHEELCHAIR BRAKES OR SWITCH OFF POWERED WHEELCHAIR.**



9. Lower the PLATFORM as follows. Re-enter the vehicle to access Manual Pump. Open release valve on Manual Pump by turning MANUAL BACKUP HANDLE counter-clockwise (FIG. 27-1). Lower the Lift slowly below floor level and check if Inboard Rollstop is raised and locked in the up position (FIG. 27-2).

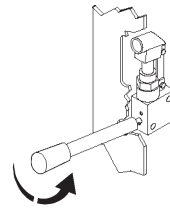

**OPEN RELEASE VALVE  
FIG. 27-1**

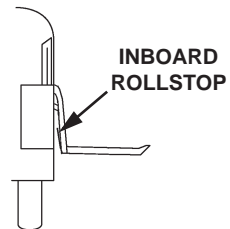

**PLATFORM LOWERED,  
INBOARD ROLLSTOP UP  
FIG. 27-2**

10. Watch PLATFORM (FIG. 27-3) as it lowers occupant to the ground.

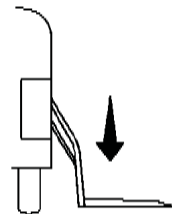

**LOWERING PLATFORM  
TO GROUND  
FIG. 27-3**

11. When PLATFORM rests on the ground, close release valve on Manual Pump by turning MANUAL BACKUP HANDLE clockwise until tight (FIG. 27-4).

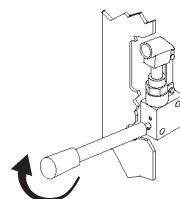

**TIGHTEN  
CLOSE RELEASE VALVE  
FIG. 27-4**

## MANUAL PUMP OPERATION - Continued

12. If equipped, unfasten SEAT BELT (FIG. 28-1). Place on hanger (FIG. 28-2).

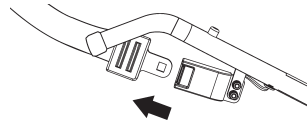

UNFASTENING SEAT BELT  
(RH HANDRAIL SHOWN)  
FIG. 28-1

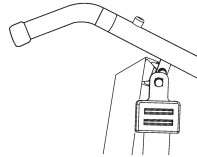

SEAT BELT ON HANGER  
(LH HANDRAIL SHOWN)  
FIG. 28-2

13. Ensure OUTBOARD ROLLSTOP on the PLATFORM is opened to the horizontal position (FIG. 28-3).

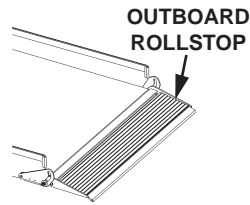

OUTBOARD ROLLSTOP IN  
HORIZONTAL POSITION  
FIG. 28-3

**NOTE:** If there are no occupants to unload, skip steps 14 & 15.

14. **RELEASE WHEELCHAIR BRAKES** or **SWITCH ON POWERED WHEELCHAIR.** Move wheelchair or ambulatory occupant into the unloading zone.
15. Position wheelchair or ambulatory occupant on the center of Platform (FIG. 28-4). **SET WHEELCHAIR BRAKES** or **SWITCH OFF POWERED WHEELCHAIR.**
16. If equipped, fasten SEAT BELT (FIG. 28-5).

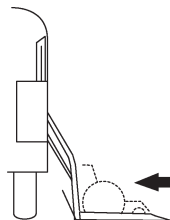

POSITIONING OCCUPANT  
ON PLATFORM  
FIG. 28-4

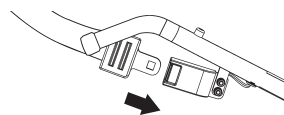

FASTENING SEAT BELT  
(RH HANDRAIL SHOWN)  
FIG. 28-5

# CAUTION

Prevent the **MANUAL BACKUP HANDLE** from getting damaged. Before you start pumping with the **HANDLE**, line up notches on tip of **HANDLE** as shown in **FIG. 29-1**. Then fully engage **HANDLE** with Manual Pump as shown in **FIG. 29-2**.

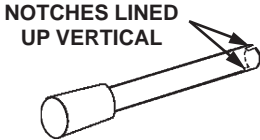

**HANDLE - NOTCHES LINED UP CORRECTLY**  
**FIG. 29-1**

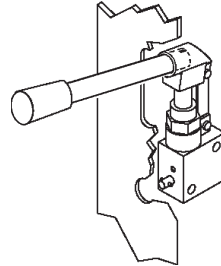

**HANDLE FULLY ENGAGED**  
**FIG. 29-2**

17. Raise the **PLATFORM** as follows. Insert **MANUAL BACK-UP HANDLE** in Manual Pump actuator. Pump the handle up and down (**FIG. 29-3**) until **PLATFORM** is raised up even with the vehicle floor (**FIG. 29-4**) and Inboard Rollstop lowers to rest on Threshold Plate.

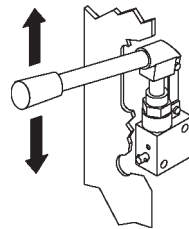

**PUMPING MANUAL BACKUP HANDLE**  
**FIG. 29-3**

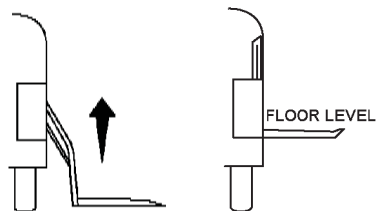

**RAISING LIFT TO VEHICLE FLOOR**  
**FIG. 29-4**

## MANUAL PUMP OPERATION - Continued

**NOTE:** If there are no occupants to load on Platform, skip step 18.

18. **RELEASE WHEELCHAIR BRAKES or SWITCH ON POWERED WHEELCHAIR.**  
Move wheelchair or ambulatory occupant inside the vehicle.

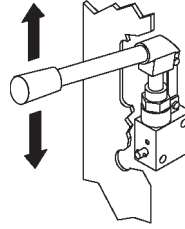

**PUMPING MANUAL  
BACKUP HANDLE  
FIG. 30-1**

19. Stow the Lift as follows.  
Pump the MANUAL BACKUP HANDLE up and down (**FIG. 30-1**) until PLATFORM folds up tightly inside the vehicle (**FIG. 30-2**)

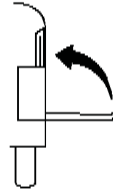

**FOLDING PLATFORM  
UP INTO VEHICLE  
FIG. 30-2**

20. Store MANUAL BACKUP HANDLE on Pump Cover (**FIG. 30-3**) using the clips provided.

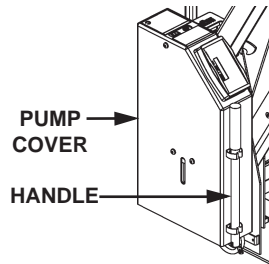

**MANUAL BACKUP HANDLE  
(LH PUMP SHOWN)  
FIG. 30-3**

