

M-03-15
REV. E
APRIL 2010

MAXON[®]

MAINTENANCE MANUAL

72-150 & TE-20

TUK-A-WAY[®]
LIFT GATE SERIES

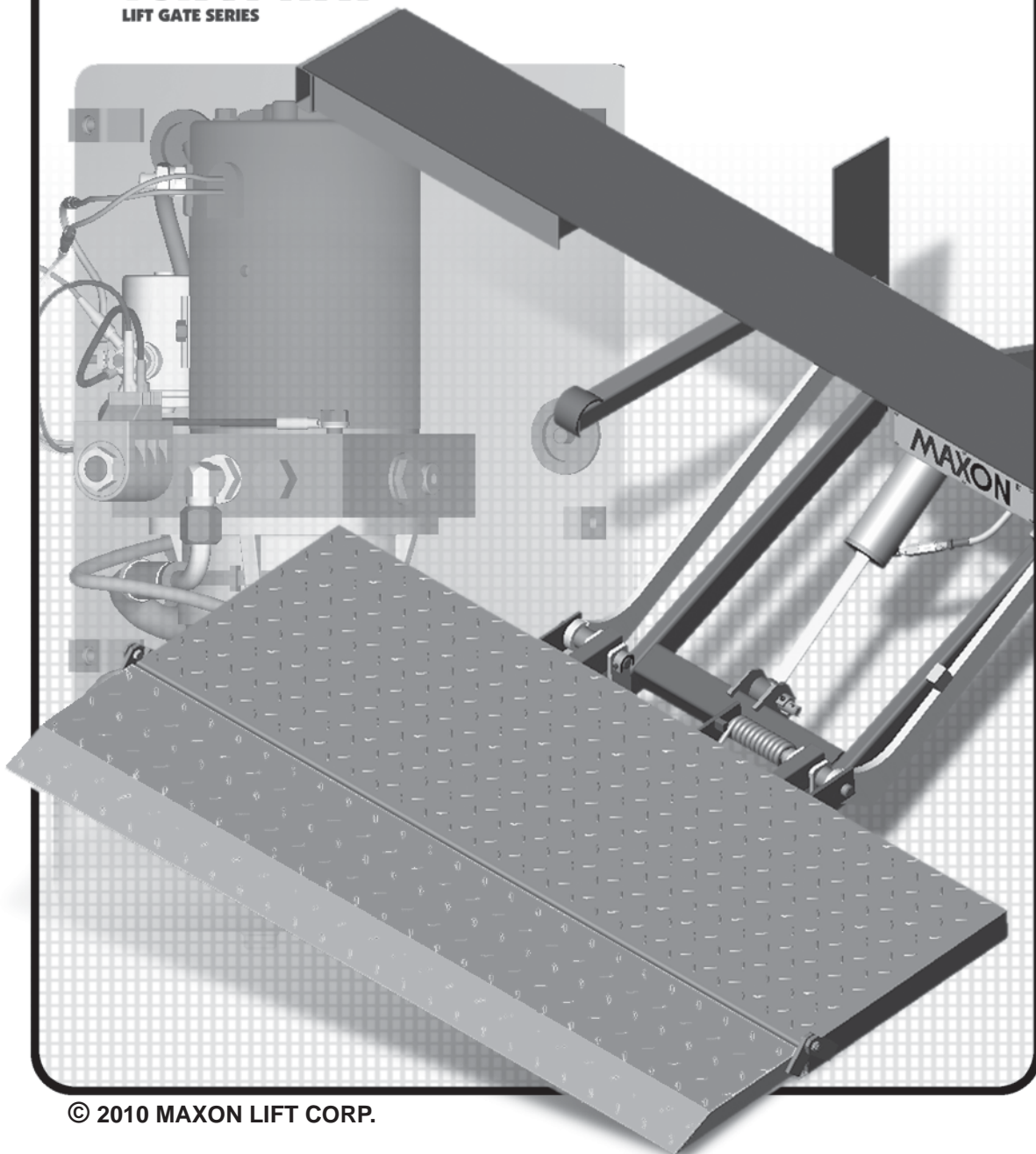

© 2010 MAXON LIFT CORP.

MAXON[®]

LIFT CORP.

11921 Slauson Ave.
Santa Fe Springs, CA. 90670

CUSTOMER SERVICE:

TELEPHONE (562) 464-0099 TOLL FREE (800) 227-4116

FAX: (888) 771-7713

NOTE: For latest version of all Manuals (and replacements), download the Manuals from Maxon's website at www.maxonlift.com.

WARRANTY/ RMA POLICY & PROCEDURE

LIFTGATE WARRANTY

Type of Warranty: Full Parts and Labor

Term of Warranty: Standard Liftgates - 2 years from ship date or 6,000 cycles
Premium Liftgates - 2 years from ship date or 10,000 cycles

This warranty shall not apply unless the product is installed, operated and maintained in accordance with MAXON Lift's specifications as set forth in MAXON Lift's Installation, Operation and Maintenance manuals. This warranty does not cover normal wear, maintenance or adjustments, damage or malfunction caused by improper handling, installation, abuse, misuse, negligence, or carelessness of operation. In addition, this warranty does not cover equipment that has had unauthorized modifications or alterations made to the product.

MAXON agrees to replace any components which are found to be defective during the first 2 years of service, and will reimburse for labor based on MAXON's Liftgate Warranty Flat Rate Schedule. (Copy of the Flat Rate is available at www.maxonlift.com.)

All warranty repairs must be performed by an authorized MAXON warranty facility. For any repairs that may exceed \$500, including parts and labor, MAXON's Technical Service Department must be notified and an "Authorization Number" obtained.

All claims for warranty must be received within 30 Days of the repair date, and include the following information:

1. Liftgate Model Number and Serial Number
2. The End User must be referenced on the claim
3. Detailed Description of Problem
4. Corrective Action Taken, and Date of Repair
5. Parts used for Repair, Including MAXON Part Number(s)
6. MAXON R.M.A. # and/or Authorization # if applicable (see below)
7. Person contacted at MAXON if applicable
8. Claim must show detailed information i.e. Labor rate and hours of work performed

Warranty claims can also be placed online at www.maxonlift.com. Online claims will be given priority processing.

All claims for warranty will be denied if paperwork has not been received or claim submitted via Maxon website for processing by MAXON's Warranty Department within 30 days of repair date.

All components may be subject to return for inspection, prior to the claim being processed. MAXON products may not be returned without prior written approval from MAXON's Technical Service Department. Returns must be accompanied by a copy of the original invoice or reference with original invoice number and are subject to a credit deduction to cover handling charges and any necessary reconditioning costs. **Unauthorized returns will be refused and will become the responsibility of the returner.**

Any goods being returned to MAXON Lift must be pre-approved for return, and have the R.M.A. number written on the outside of the package in plain view, and returned freight prepaid. All returns are subject to a 15% handling charge if not accompanied by a detailed packing list. Returned parts are subject to no credit and returned back to the customer. Defective parts requested for return must be returned within 30 days of the claim date for consideration to:

MAXON Lift Corp.
10321 Greenleaf Ave., Santa Fe Springs, CA 90670
Attn: RMA# _____

MAXON's warranty policy does not include the reimbursement for travel time, towing, vehicle rental, service calls, oil, batteries or loss of income due to downtime. Fabrication or use of non Maxon parts, which are available from MAXON, are also not covered.

MAXON's Flat Rate Labor Schedule takes into consideration the time required for diagnosis of a problem.

All Liftgates returned are subject to inspection and a 15% restocking fee. Any returned Liftgates or components that have been installed or not returned in new condition will be subject to an additional reworking charge, which will be based upon the labor and material cost required to return the Liftgate or component to new condition.

PURCHASE PART WARRANTY

Term of Warranty: 1 Year from Date of Purchase.

Type of Warranty: Part replacement only. MAXON will guarantee all returned genuine MAXON replacement parts upon receipt and inspection of parts and original invoice.

All warranty replacements parts will be sent out via ground freight. If a rush shipment is requested, all freight charges will be billed to the requesting party.

TABLE OF CONTENTS

WARNING	6
LIFTGATE TERMINOLOGY	9
PERIODIC MAINTENANCE	10
PERIODIC MAINTENANCE CHECKS	10
PERIODIC MAINTENANCE CHECKLIST	11
CHECKING HYDRAULIC FLUID	12
CHANGING HYDRAULIC FLUID	14
PLATFORM ADJUSTMENT	16
REPLACING PLATFORM TORSION SPRING	19
SAFETY HOOK MAINTENANCE	21
PARTS BREAKDOWN	23
72-150 & TE-20 MAIN ASSEMBLY	23
EXTENSION PLATE ASSEMBLY	24
LIFT FRAME & PARALLEL ARMS	25
PLATFORM & FLIPOVER ASSEMBLY (RAMP)	26
PLATFORM & FLIPOVER ASSEMBLY (WEDGE)	27
PUMP COVER & MOUNTING PLATE ASSEMBLY (GRAVITY DOWN)	28
PUMP COVER & MOUNTING PLATE ASSEMBLY (POWER DOWN)	29
GRAVITY DOWN HYDRAULIC COMPONENTS	31
12 VDC POWER UNIT (GRAVITY DOWN)	32
24 VDC POWER UNIT (GRAVITY DOWN)	34
POWER DOWN HYDRAULIC COMPONENTS	37
12 VDC POWER UNIT (POWER DOWN)	38
DECALS	40

CONTROL SWITCH AND POWER CABLE	41
HYDRAULIC SYSTEM DIAGRAMS	42
HYDRAULIC SCHEMATIC (GRAVITY DOWN).....	42
HYDRAULIC SCHEMATIC (POWER DOWN)	43
ELECTRICAL SYSTEM DIAGRAMS	44
ELECTRICAL SCHEMATIC (GRAVITY DOWN)	44
ELECTRICAL SCHEMATIC (POWER DOWN)	45
TROUBLESHOOTING	46
PLATFORM WILL NOT RAISE.....	46
PLATFORM RAISES BUT LEAKS DOWN	47
PLATFORM RAISES PARTIALLY AND STOPS.....	48
LIFTGATE WILL NOT LIFT RATED CAPACITY	49
PLATFORM RAISES SLOWLY	50
PLATFORM WILL NOT LOWER, LOWERS TOO SLOWLY OR TOO QUICKLY	51

Comply with the following **WARNINGS** while maintaining Liftgates. See Operation Manual for operating safety requirements.

⚠ WARNING

- Read and understand the instructions in this **Maintenance Manual** before performing maintenance on the Liftgate.
- Before operating the Liftgate, read and understand the operating instructions in **Operation Manual**.
- Comply with all **WARNING** and instruction decals attached to the Liftgate.
- Keep decals clean and legible. If decals are illegible or missing, replace them. Free replacement decals are available from **Maxon Customer Service**.
- Consider the safety and location of bystanders and location of nearby objects when operating the Liftgate. Stand to one side of the platform while operating the Liftgate
- Do not allow untrained persons to operate the Liftgate.
- Do not stand, or allow obstructions, under the platform when lowering the Liftgate. **Be sure your feet are clear of the Liftgate.**
- **Keep fingers, hands, arms, legs, and feet clear of moving Liftgate parts (and platform edges) when operating the Liftgate.**
- **Correctly stow platform when not in use. Extended platforms could create a hazard for people and vehicles passing by.**
- **Disconnect Liftgate power cable from battery** before repairing or servicing Liftgate.
- Wear appropriate safety equipment such as protective eyeglasses, faceshield and clothing while performing maintenance on the Liftgate and handling the battery. Debris from drilling and contact with battery acid may injure unprotected eyes and skin.
- Be careful working by an automotive type battery. Make sure the work area is well ventilated and there are no flames or sparks near the battery. Never lay objects on the battery that can short the terminals together. If battery acid gets in your eyes, immediately seek first aid. If acid gets on your skin, immediately wash it off with soap and water.
- If an emergency situation arises (vehicle or Liftgate) while operating the Liftgate, release the control switch to stop the Liftgate.
- A correctly installed Liftgate operates smoothly and reasonably quiet. The only noticeable noise during operation comes from the power unit while the platform is raised. Listen for scraping, grating and binding noises and correct the problem before continuing to operate Liftgate.
- If it is necessary to stand on the platform while maintaining the Liftgate, keep your feet and any objects clear of the inboard edge of the platform. Your feet or objects on the platform could be trapped between the platform and the Liftgate extension plate.
- Never perform unauthorized modifications on the Liftgate. Modifications may result in early failure of the Liftgate and may create hazards for Liftgate operators and maintainers.

MAXON[®]

11921 Slauson Ave. Santa Fe Springs, CA. 90670 (800) 227-4116 FAX (888) 771-7713

- Use only **Maxon Authorized Parts** for replacement parts. Provide Liftgate model and serial number information with your parts order. Order replacement parts from:

MAXON LIFT CORP. Customer Service
11921 Slauson Ave., Santa Fe Springs, CA 90670
Phone: (800) 227-4116

- To order parts by e-mail, submit orders to **cservice@maxonlift.com**.
- Recommended practices for welding on steel parts are contained in the current **AWS (American Welding Society) D1.1 Structural Welding Code - Steel**. Damage to Liftgate and/or vehicle, and personal injury could result from welds that are done incorrectly.
- Recommended practices for welding on aluminum parts are contained in the current **AWS (American Welding Society) D2.1 Structural Welding Code - Aluminum**. Damage to Liftgate and/or vehicle, and personal injury could result from welds that are done incorrectly.

THIS PAGE INTENTIONALLY LEFT BLANK

MAXON[®]

11921 Slauson Ave. Santa Fe Springs, CA. 90670 (800) 227-4116 FAX (888) 771-7713

LIFTGATE TERMINOLOGY

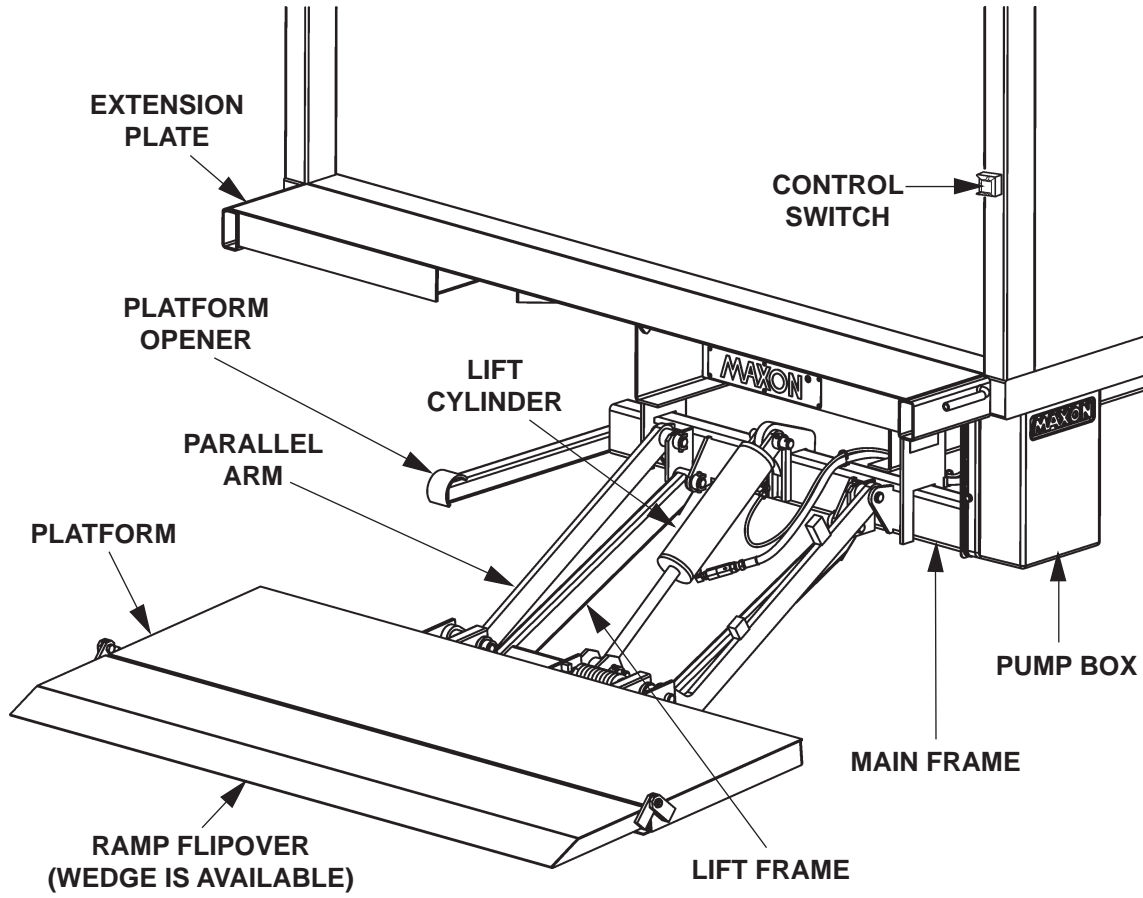

PERIODIC MAINTENANCE

PERIODIC MAINTENANCE CHECKS

WARNING

Never operate the Liftgate with parts loose or missing.

NOTE: Make sure vehicle is parked on level ground while performing the maintenance checks.

Quarterly or 1250 Cycles (whichever occurs first)

Check the hydraulic fluid level in the pump reservoir. Refer to the **CHECKING HYDRAULIC FLUID** procedure in the **PERIODIC MAINTENANCE** section.

If hydraulic fluid appears contaminated, refer to the **CHANGING HYDRAULIC FLUID** procedure in the **PERIODIC MAINTENANCE** section.

Keep track of the grade of hydraulic fluid in the pump reservoir and never mix two different grades of fluid.

Check all hoses and fittings for chafing and fluid leaks. Tighten loose fittings or replace parts as required.

Check electrical wiring for chafing and make sure wiring connections are tight and free of corrosion. Use dielectric grease to protect electrical connections.

Check that all **WARNING and instruction decals** are in place. Also, make sure decals are legible and decals are clean and undamaged.

Check that all bolts, nuts, and roll pins are in place. Make sure roll pins protrude evenly from both sides of hinge pin collar. Replace fasteners and roll pins if necessary.

Check for rust and oily surfaces on Liftgate. If there is rust or oil on Liftgate or if the Liftgate is dirty, clean it off. Touch up the paint where bare metal is showing. To maintain the protection provided by the original paint system, **MAXON** recommends aluminum primer touchup paint kit, P/N 908134-01.

Semi-annually or 2500 Cycles (whichever occurs first)

Visually check the platform hinge pins for excessive wear and broken welds. See **PARTS BREAKDOWN** section for replacement parts. Also, do the **Quarterly or 1250 Cycles** maintenance checks.

PERIODIC MAINTENANCE CHECKLIST

NOTE: Make sure vehicle is parked on level ground while performing the maintenance checks.

Quarterly or 1250 Cycles (whichever occurs first)

- Check the level and condition of the hydraulic fluid.
- Visually check all hoses for chafing and fluid leaks. Tighten loose fittings or replace parts as required.
- Check electrical wiring for chafing and make sure wiring connections are tight and free of corrosion. Use dielectric grease to protect electrical connections.
- Check that all **WARNING and instruction decals** are in place. Also, make sure decals are legible and decals are clean and undamaged.
- Check that all bolts, nuts, and roll pins are in place. Make sure roll pins protrude evenly from both sides of hinge pin collar. Replace fasteners and roll pins if necessary.

CAUTION

Damaged cylinder seals and contaminated hydraulic fluid can result from painting the polished portion of the cylinder rod. To prevent damage, protect the exposed polished portion of the cylinder rod while painting.

- Check for rust and oily surfaces on Liftgate. If there is rust or oil on Liftgate or if the Liftgate is dirty, clean it off. Touch up the paint where bare metal is showing. To maintain the protection provided by the original paint system, **MAXON** recommends aluminum primer touchup paint kit, P/N 908134-01.

Semi-annually or 2500 Cycles (whichever occurs first)

- Visually check the platform hinge pins for excessive wear and broken welds.
- Do the **Quarterly or 1250 Cycles Checks** on this checklist.

PERIODIC MAINTENANCE CHECKING HYDRAULIC FLUID

MAXON®
 11921 Slauson Ave. Santa Fe Springs, CA. 90670 (800) 227-4116 FAX (888) 771-7713

CAUTION

Keep dirt, water and other contaminants from entering the hydraulic system. Before opening the hydraulic fluid reservoir filler cap, drain plug and hydraulic lines, clean up contaminants that can get in the openings. Also, protect the openings from accidental contamination.

NOTE: Use correct grade of hydraulic fluid for your location.
+50 to +120 Degrees F - Grade ISO 32
Below + 70 Degrees F - Grade ISO 15 or MIL-H-5606
 See **TABLES 13-2 and 13-3** for recommended brands.

1. Unbolt & remove pump cover (FIG. 12-1).

NOTE: If the hydraulic fluid in the reservoir is contaminated, do the **CHANGING HYDRAULIC FLUID** procedure in this section.

NOTE: If you have a power down power unit, skip instructions 2 & 3.

2. For gravity down power unit, check the hydraulic fluid level "H" in reservoir (FIG. 12-2 and TABLE 12-1). If needed, add fluid to the reservoir as follows.

PLATFORM POSITION	FLUID LEVEL "H"
STOWED	1-7/8" to 2-3/8"
VEHICLE BED HEIGHT	1-7/8" to 2-3/8"
ON THE GROUND	3-1/2" to 4"

**GRAVITY DOWN FLUID LEVEL
TABLE 12-1**

3. Pull out (no threads) filler cap (FIG. 12-2). Fill the reservoir with hydraulic fluid to level "H" shown in FIG. 12-2 and TABLE 12-1. Reinstall filler cap (FIG. 12-2).

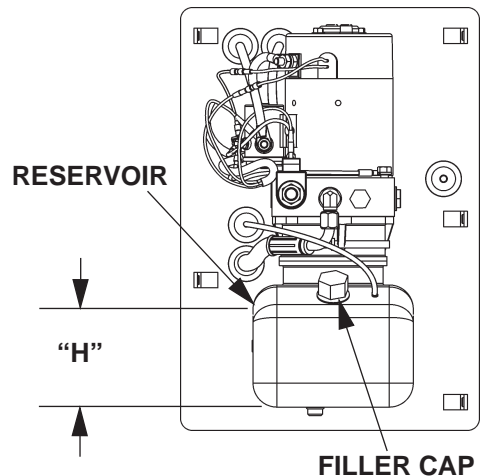
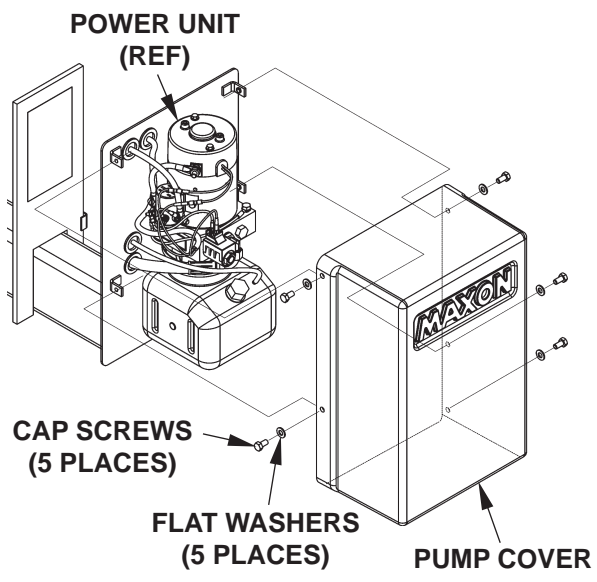

4. For power down power unit, check the hydraulic fluid level “H” in reservoir (**FIG. 13-1** and **TABLE 13-1**). If needed, add fluid to the reservoir as follows.

PLATFORM POSITION	FLUID LEVEL “H”
STOWED	2-5/8” to 3-1/8”
VEHICLE BED HEIGHT	2-5/8” to 3-1/8”
ON THE GROUND	2-3/8” to 2-7/8”

**POWER DOWN FLUID LEVEL
TABLE 13-1**

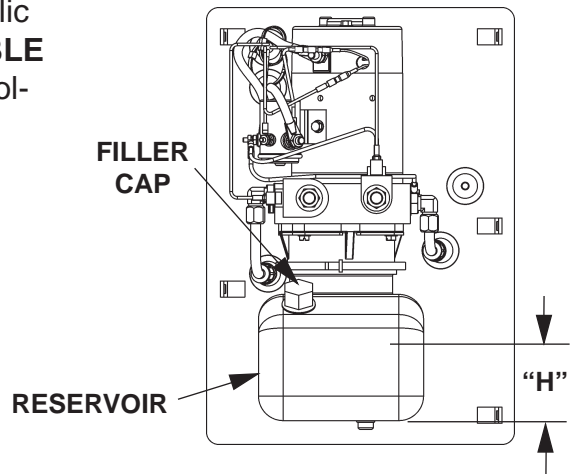

**POWER DOWN POWER UNIT
FIG. 13-1**

5. Pull out (no threads) filler cap (**FIG. 13-1**). Fill the reservoir with hydraulic fluid to level “H” shown in **FIG. 13-1** and **TABLE 13-1**. Reinstall filler cap (**FIG. 13-1**).

6. Bolt on the pump cover (**FIG. 12-1**). Torque the bolts (cap screws) to **10 - 14 lbs.- in.**

ISO 32 HYDRAULIC OIL	
RECOMMENDED BRANDS	PART NUMBER
AMSOIL	AWH-05
CHEVRON	HIPERSYN 32
KENDALL	GOLDEN MV
SHELL	TELLUS S2 V32
EXXON	UNIVIS N-32
MOBIL	DTE-13M, DTE-24, HYDRAULIC OIL-13

TABLE 13-2

ISO 15 OR MIL-H-5606 HYDRAULIC OIL	
RECOMMENDED BRANDS	PART NUMBER
AMSOIL	AWF-05
CHEVRON	FLUID A, AW-MV-15
KENDALL	GLACIAL BLU
SHELL	TELLUS S2 V15
EXXON	UNIVIS HVI-13
MOBIL	DTE-11M
ROSEMEAD	THS FLUID 17111

TABLE 13-3

PERIODIC MAINTENANCE CHANGING HYDRAULIC FLUID

CAUTION

Keep dirt, water and other contaminants from entering the hydraulic system. Before opening the hydraulic fluid reservoir filler cap, drain plug and hydraulic lines, clean up contaminants that can get in the openings. Also, protect the openings from accidental contamination.

NOTE: Use correct grade of hydraulic fluid for your location.

+50 to +120 Degrees F - Grade ISO 32

Below + 70 Degrees F - Grade ISO 15 or MIL-H-5606

See **TABLES 13-2 and 13-3** for recommended brands.

GRAVITY DOWN LIFTGATES

1. Remove the pump cover (**FIG. 15-1**). Place empty 5 gallon bucket under drain plug (**FIG. 14-1**).
2. Lower platform to ground. Pull out (no threads) drain plug (**FIG. 14-1**). Drain hydraulic fluid from system. Reinstall drain plug.
3. Pull out (no threads) filler cap (**FIG. 14-1**) and refill reservoir with hydraulic fluid to level shown in **FIG. 14-1**. Reinstall filler cap (**FIG. 14-1**).
4. Bolt on the pump cover as shown in **FIG. 15-1**. Torque the bolts (cap screws) to **10 - 14 lbs.- in.**

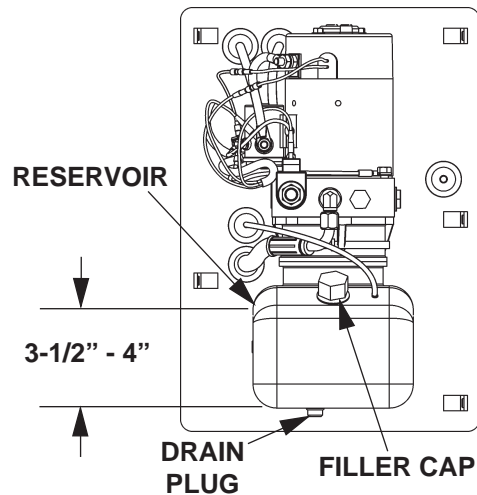

**LIFTGATE SHOWN WITH GRAVITY
DOWN PUMP & MOTOR**

FIG. 14-1

POWER DOWN LIFTGATES

1. Remove the pump cover (**FIG. 15-1**). Place empty 5 gallon bucket under drain plug (**FIG. 14-1**).
2. Open and raise platform to vehicle bed height. Pull out (no threads) drain plug (**FIG. 14-1**). Drain hydraulic fluid.
3. Disconnect the motor power cable (**FIG. 14-2**) from starter solenoid. Lower the platform while draining the remaining hydraulic fluid from system. Reinstall drain plug. Reconnect the motor power cable to starter solenoid.
4. Pull out (no threads) filler cap (**FIG. 14-1**) and refill reservoir with hydraulic fluid to level shown in **FIG. 14-1**. Reinstall filler cap (**FIG. 14-1**).

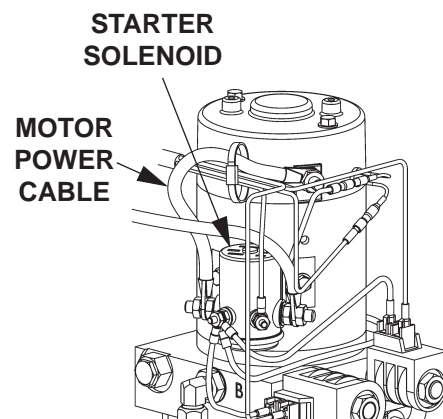

POWER DOWN PUMP
FIG. 14-2

5. Bolt on the pump cover as shown in **FIG. 15-1**. Torque the bolt (cap screws) to **10 - 14 lbs.- in.**

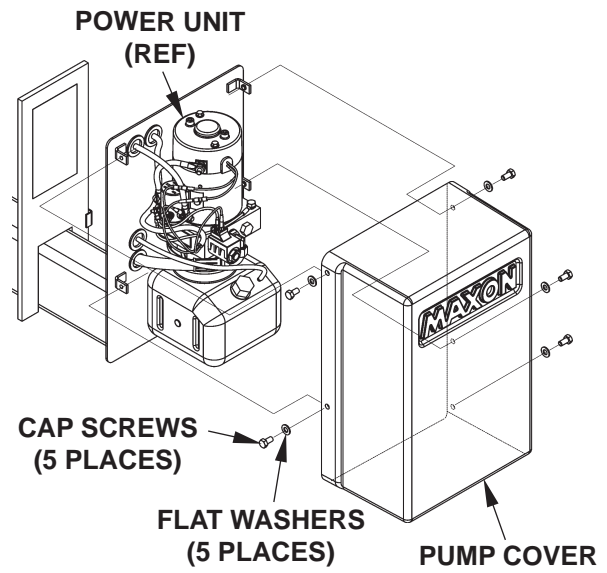

UNBOLTING / BOLTING PUMP COVER
FIG. 15-1

PERIODIC MAINTENANCE PLATFORM ADJUSTMENT

NOTE: Before doing the following procedure, make sure vehicle is parked on level ground.

1. Make sure platform is at ground level. Unfold the platform and flipover. As the platform first touches the ground, shackles and tip of flipover must touch the ground at the same time (**FIG. 16-1**). If the shackles and the tip of flipover touch the ground at the same time, **RAISE** platform to bed height. Outboard edge on top of flipover should be above bed level (**FIG. 16-2**). If indications are correct in both cases (**FIGS. 16-1 and 16-2**), Liftgate is installed correctly and no adjustment is needed. If indications are incorrect, continue with instruction 2.

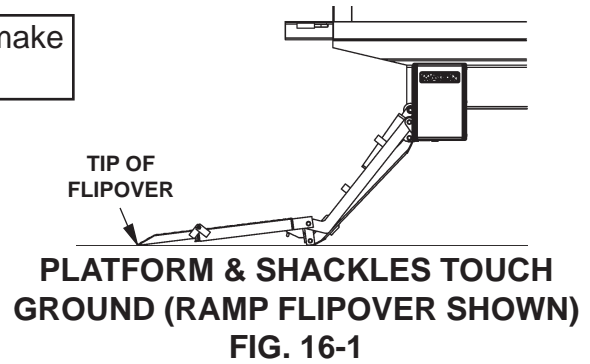

NOTE: If tip of flipover touches first (**FIG. 16-3A**), do instructions 2 and 3. If the shackle touches first (see **FIG. 18-1**), skip 2 and 3 and do instructions 4 and 5.

2. Make sure platform is still at ground level. If the shackle is not touching the ground, measure and compare distance "A" (**FIG. 16-3A**) with **TABLES 16-1 or TABLE 16-2** to determine the correct shim. Next, mark position on shackle (**FIG. 16-3B**).

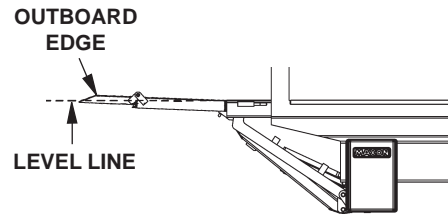

RAISE TIP OF RAMP FLIPOVER THIS DISTANCE "A"	REQUIRED SHIM THICKNESS	WELD SIZE "W"
11/16"	1/16"	1/16"
1-3/8"	1/8"	1/8"
2-1/16"	3/16"	3/16"
2-3/4"	1/4"	1/4"

**SHIMS TO RAISE RAMP FLIPOVER
TABLE 16-1**

RAISE TIP OF RAMP FLIPOVER THIS DISTANCE "A"	REQUIRED SHIM THICKNESS	WELD SIZE "W"
9/16"	1/16"	1/16"
1-1/4"	1/8"	1/8"
1-15/16"	3/16"	3/16"
2-5/8"	1/4"	1/4"

**SHIMS TO RAISE WEDGE FLIPOVER
TABLE 16-2**

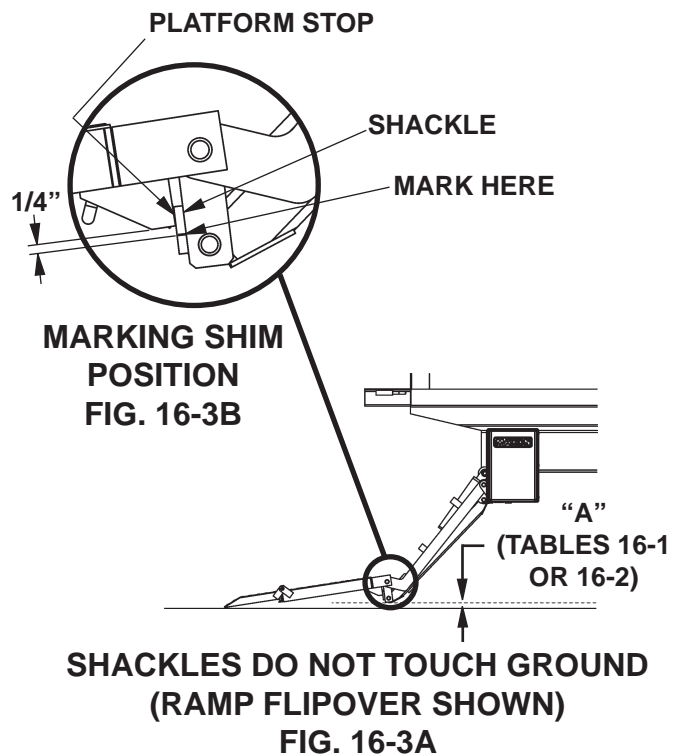

3. Make shims as needed (**FIG. 17-1**). Position bottom edge of shim to line up with mark on shackle (**see FIG. 16-3B**). Next, weld the shim to shackle as shown in **FIG. 17-2**.

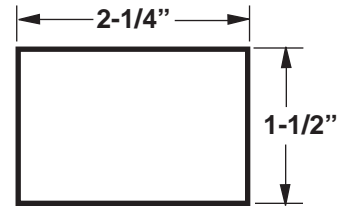

**SHIM (1/16", 1/8", 3/16", or 1/4")
MADE FROM STEEL FLAT
FIG. 17-1**

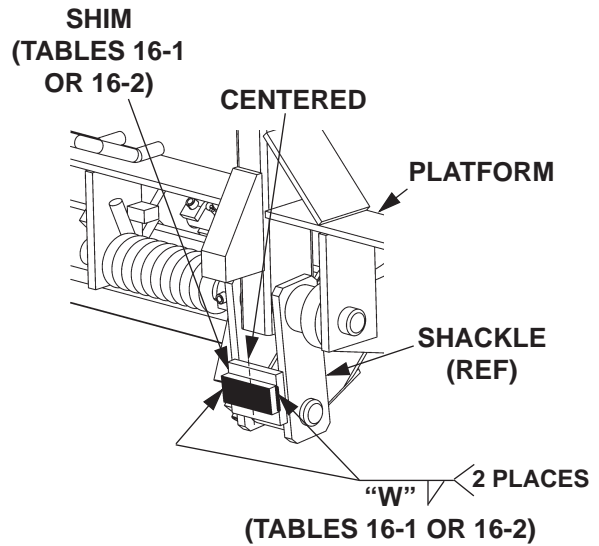

**WELDING SHIMS (RH SHACKLE SHOWN)
FIG. 17-2**

PERIODIC MAINTENANCE PLATFORM ADJUSTMENT - Continued

4. Make sure platform is still at ground level. If the tip of flipover is not touching the ground, measure and compare distance "B" (FIG. 18-1) with TABLES 18-1 or TABLE 18-2 to determine how much to grind from the platform stops (FIG. 18-2).

LOWER TIP OF RAMP FLIPOVER THIS DISTANCE "B"	GRIND METAL FROM PLATFORM STOP
11/16"	1/16"
1-3/8"	1/8"
2-1/16"	3/16"
2-3/4"	1/4"

**SHIMS TO LOWER RAMP FLIPOVER
TABLE 18-1**

LOWER TIP OF WEDGE FLIPOVER THIS DISTANCE "B"	GRIND METAL FROM PLATFORM STOP
9/16"	1/16"
1-1/4"	1/8"
1-15/16"	3/16"
2-5/8"	1/4"

**SHIMS TO LOWER WEDGE FLIPOVER
TABLE 18-2**

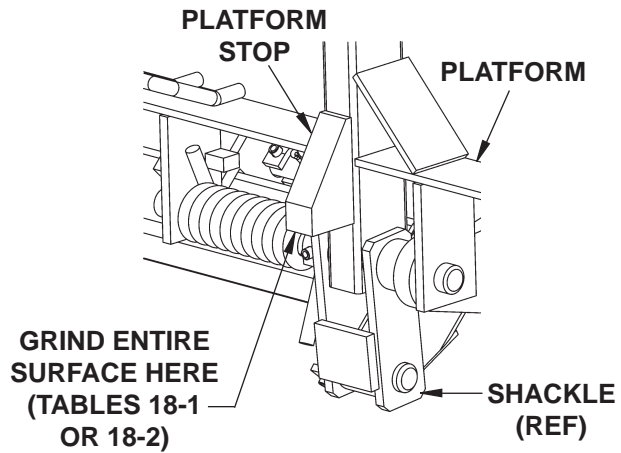
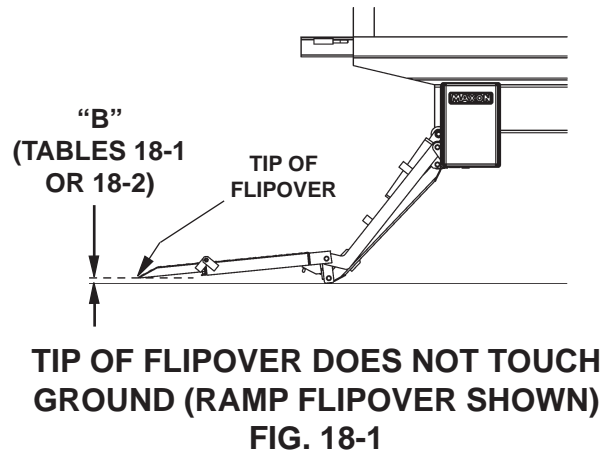

5. Grind correct amount of metal (TABLES 18-1 or 18-2) from platform stop as shown in FIG. 18-2.

6. **RAISE** the platform, then **LOWER** it to the ground. As the platform first touches the ground, the tip of flipover and shackle should touch at the same time as shown in FIG. 18-3.

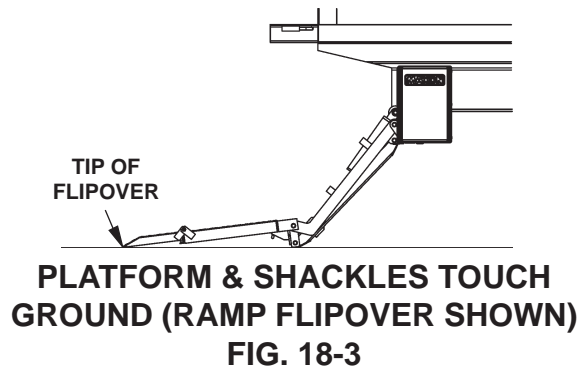

REPLACING PLATFORM TORSION SPRING

1. Fold flipover onto platform.
2. Fold platform.
3. Raise Liftgate to a convenient work height to gain access and release tension on the torsion spring.

CAUTION

To prevent injury and equipment damage, make sure there is no tension on torsion spring before removing hinge pin.

4. Drive out the roll pin from pin collar on the platform hinge bracket. Drive the platform hinge pin outboard from the shackle just enough to free the torsion spring (**FIG. 19-1**). Remove torsion spring.

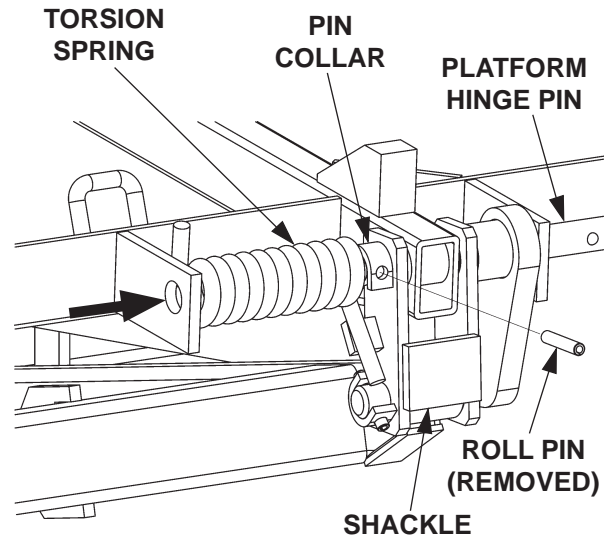

FIG. 19-1

5. Install the torsion spring as shown in (**FIG. 19-2**). Make sure the long leg of the spring is resting against the block on the shackle (**FIG. 19-2**). Make sure the short end of the spring is positioned as shown in **FIG. 19-2**.

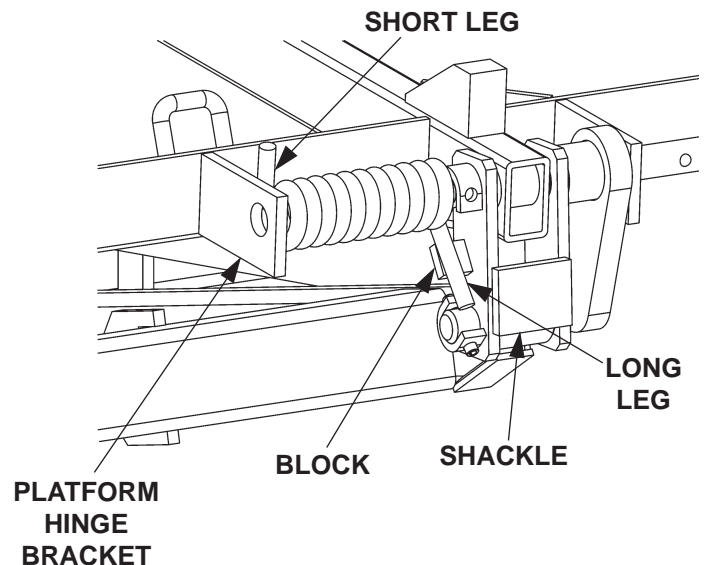

FIG. 19-2

PERIODIC MAINTENANCE

REPLACING PLATFORM TORSION SPRING - Continued

6. Drive platform hinge pin inboard to correct position through the platform hinge bracket (**FIG. 20-1**). Line up the hole in the platform hinge pin with the hole in the pin collar. Install the roll pin through the pin collar until roll pin protrudes equally from both sides of the collar (**FIG. 20-1**).
7. Operate the Liftgate according to instructions in **Operation Manual** to make sure it operates correctly.

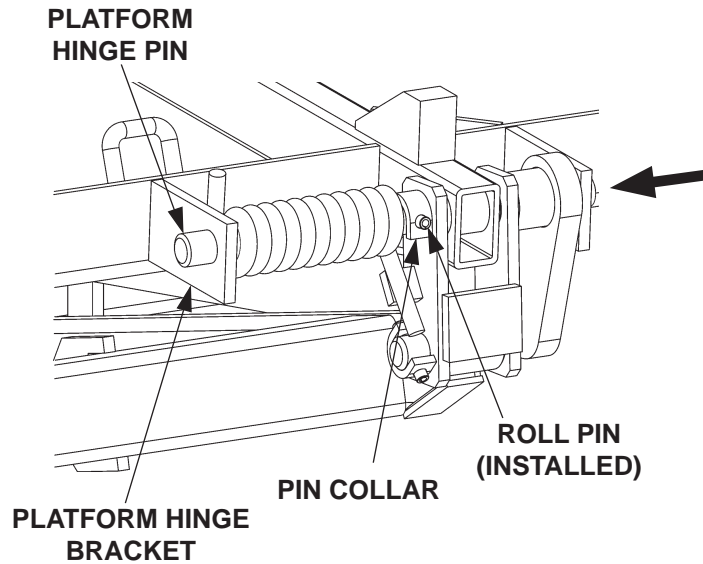

FIG. 20-1

SAFETY HOOK MAINTENANCE

CHECK SAFETY HOOK FUNCTION

1. When raising platform to stowed position, listen for sound of **safety hook** engaging **platform loop**.
2. When the Liftgate is stowed, see if **platform loop** is positioned above the **safety hook** as shown in **FIG. 21-1**.

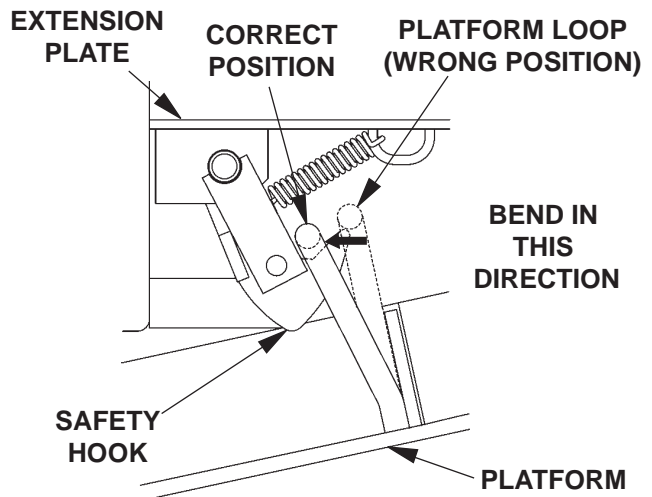

FIG. 21-1

LOOP ADJUSTMENT

1. If the safety hook is not positioned correctly, **LOWER** platform to ground level (**Operation Manual**).
2. Adjust by bending the platform loop as shown in **FIG. 21-1**.
3. Stow the platform and check for correct safety hook position. Repeat adjustment if required.

LUBRICATION (IF REQUIRED)

1. Make sure front surface of safety hook **FIG. 21-2** is lubricated with automotive grease. Apply grease if required.
2. Make sure control handle rod (**FIG. 21-2**) is lubricated where it has contact with brackets. Apply automotive grease if required.

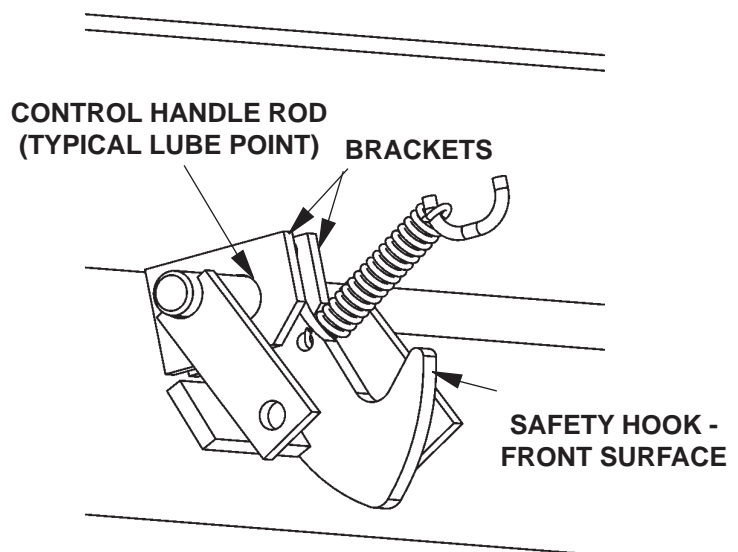

FIG. 21-2

THIS PAGE INTENTIONALLY LEFT BLANK

MAXON[®]

11921 Slauson Ave. Santa Fe Springs, CA. 90670 (800) 227-4116 FAX (888) 771-7713

PARTS BREAKDOWN

72-150 & TE-20 MAIN ASSEMBLY

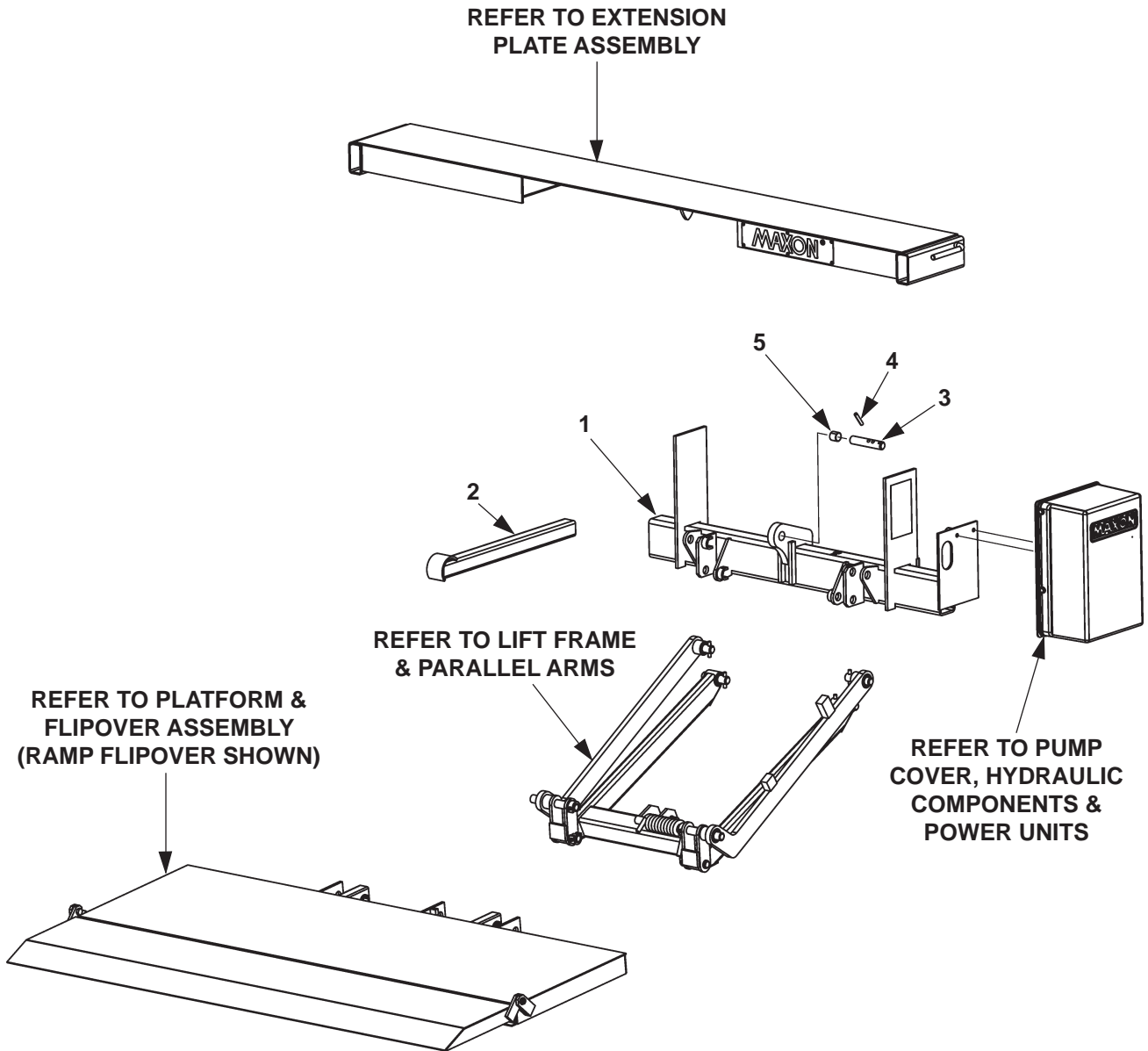

ITEM	QTY.	PART NO.	DESCRIPTION
1	1	266416-01	MAIN FRAME, 72-150 & TE-20
2	1	226046	PLATFORM OPENER
3	1	261895	PIN, 1" DIA X 5-1/8" LG.
4	1	221416	ROLL PIN, 3/8" X 2" LG.
5	1	260916-06	SELF LUBE BEARING, 1" DIA X 1" LG.

EXTENSION PLATE ASSEMBLY

VIEWED FROM UNDER
EXTENSION PLATE

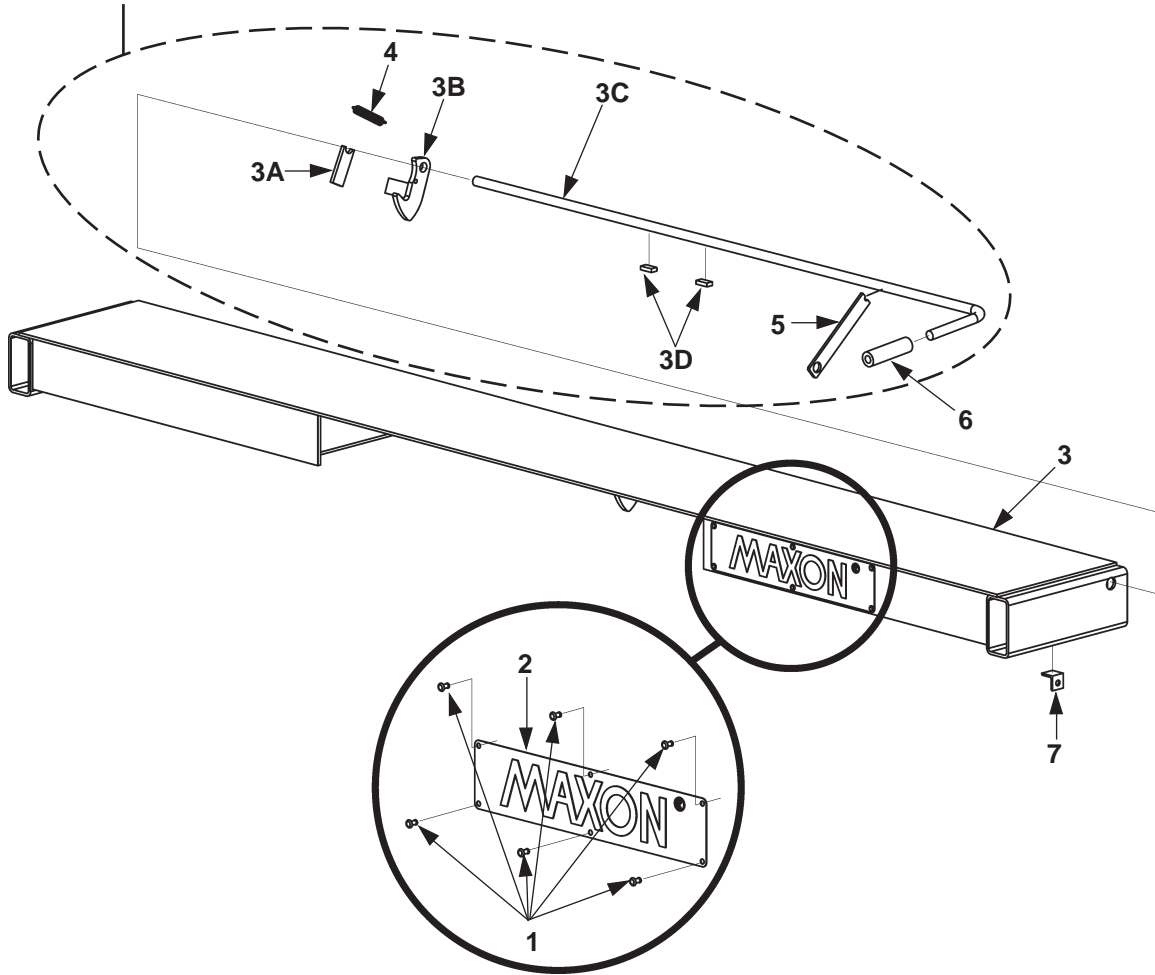

ITEM	QTY.	PART NO.	DESCRIPTION
1	6	207644	RIVET, 3/16" DIA, .40" LG
2	1	050175	MAXON PLATE
3	1	263000	EXTENSION PLATE WELDMENT
3A	1	215342	SPRING LEVER, 2-1/2" LG
3B	1	215341	SAFETY HOOK WELDMENT
3C	1	201606	HOOK RELEASE HANDLE, 5/8" X 52-3/4" LG
3D	2	201561	FLAT, 1/2" X 1/4"
4	1	215345	EXTENSION SPRING, 7/64" X 2-1/2" LG
5	1	203417	RENTAL LOCK BRACKET (OPTIONAL)
6	1	055011	HANDLE
7	1	203570	INNER BRACKET, RENTAL LOCK (OPTIONAL)

MAXON®

11921 Slauson Ave. Santa Fe Springs, CA. 90670 (800) 227-4116 FAX (888) 771-7713

LIFT FRAME & PARALLEL ARMS

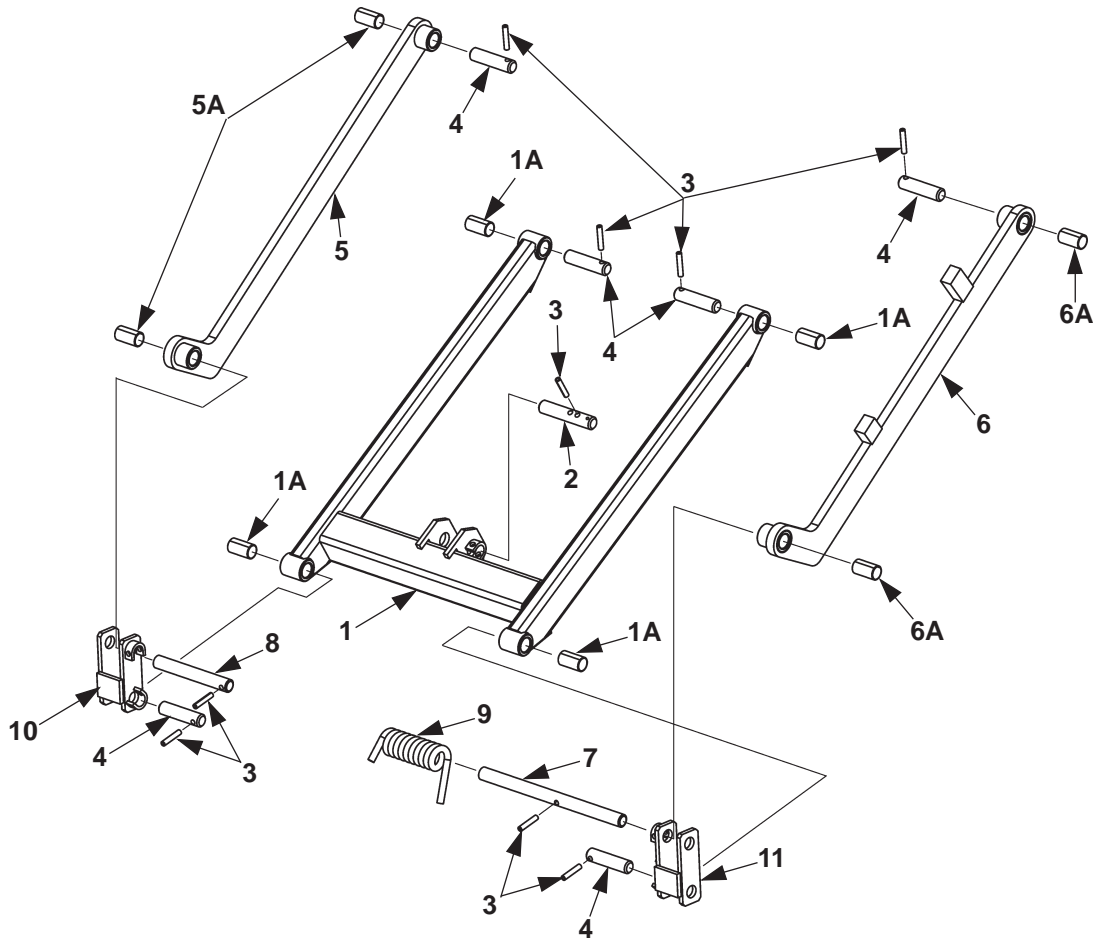

ITEM	QTY.	PART NO.	DESCRIPTION
1	1	262964	LIFT FRAME
1A	4	260916-03	SELF LUBE BEARING, 1" DIA. X 1" LG.
2	1	261895	PIN, 1" DIA. X 5-1/8" LG.
3	9	221416	ROLL PIN, 3/8" X 2" LG.
4	6	252686	PIN, 1" DIA. X 4" LG.
5	1	262965-01	PARALLEL ARM, LH
5A	2	260916-03	SELF LUBE BEARING, 1" DIA X 1" LG.
6	1	262965-02	PARALLEL ARM, LH
6A	2	260916-03	SELF LUBE BEARING, 1" DIA X 1" LG.
7	1	262981	PIN 1" DIA. X 14" LG.
8	1	260830	PIN 1" DIA. X 7-1/4" LG.
9	1	201640	TORSION SPRING
10	1	262979-01	SHACKLE ASSEMBLY, LH
11	1	262979-02	SHACKLE ASSEMBLY, RH

PLATFORM & FLIPOVER ASSEMBLY (RAMP)

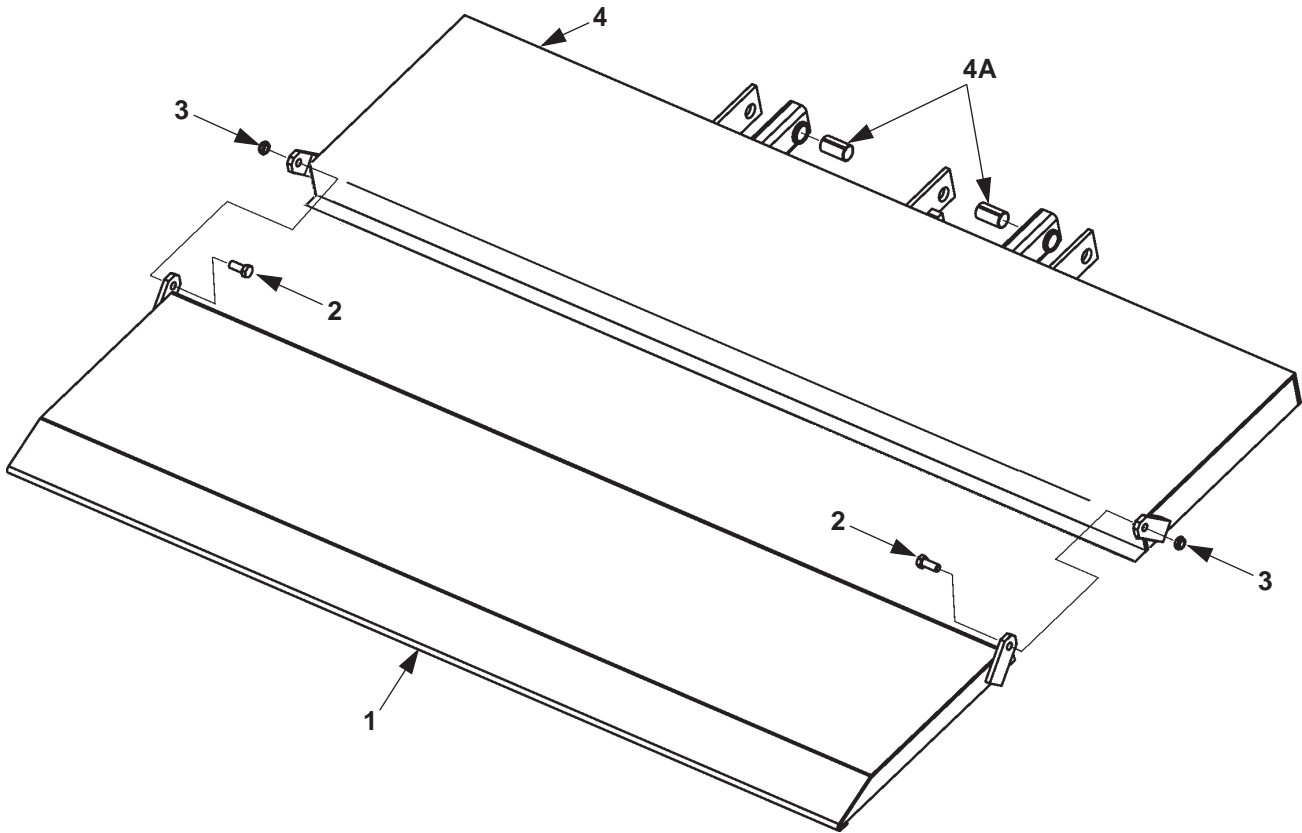

ITEM	QTY.	PART NO.	DESCRIPTION
1	1	205012	RAMP FLIPOVER (72" WIDE, 10" + 4" DEEP RAMP)
	1	205012-01	RAMP FLIPOVER (84" WIDE, 10" + 4" DEEP RAMP)
2	2	900033-2	CAP SCREW, 1/2"-20 x 1-1/4" LG.
3	2	901016-1	LOCK NUT, THIN HEAD, 1/2"-20
4	1	262975-01	PLATFORM (72" WIDE, 22" DEEP)
	1	262975-02	PLATFORM (84" WIDE, 22" DEEP)
4A	2	260916-03	BEARING, SELF LUBE

MAXON®

11921 Slauson Ave. Santa Fe Springs, CA. 90670 (800) 227-4116 FAX (888) 771-7713

PLATFORM & FLIPOVER ASSEMBLY (WEDGE)

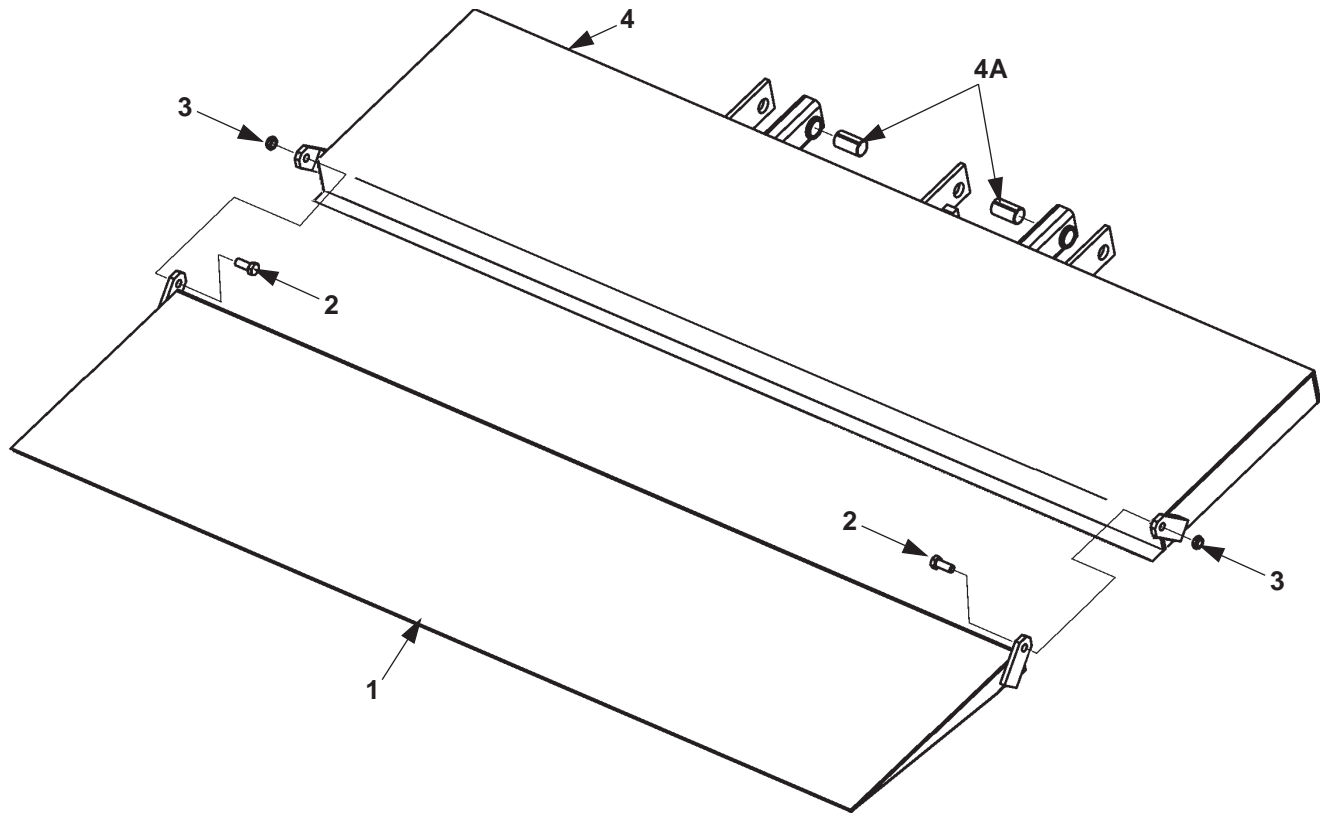

ITEM	QTY.	PART NO.	DESCRIPTION
1	1	266966-01	WEDGE FLIPOVER (72" WIDE, 14" DEEP WEDGE)
	1	266966-02	WEDGE FLIPOVER (84" WIDE, 14" DEEP WEDGE)
2	2	900033-2	CAP SCREW, 1/2"-20 x 1-1/4" LG.
3	2	901016-1	LOCK NUT, THIN HEAD, 1/2"-20
4	1	262975-01	PLATFORM (72" WIDE, 22" DEEP)
	1	262975-02	PLATFORM (84" WIDE, 22" DEEP)
4A	2	260916-03	BEARING, SELF LUBE

PUMP COVER & MOUNTING PLATE ASSEMBLY (GRAVITY DOWN)

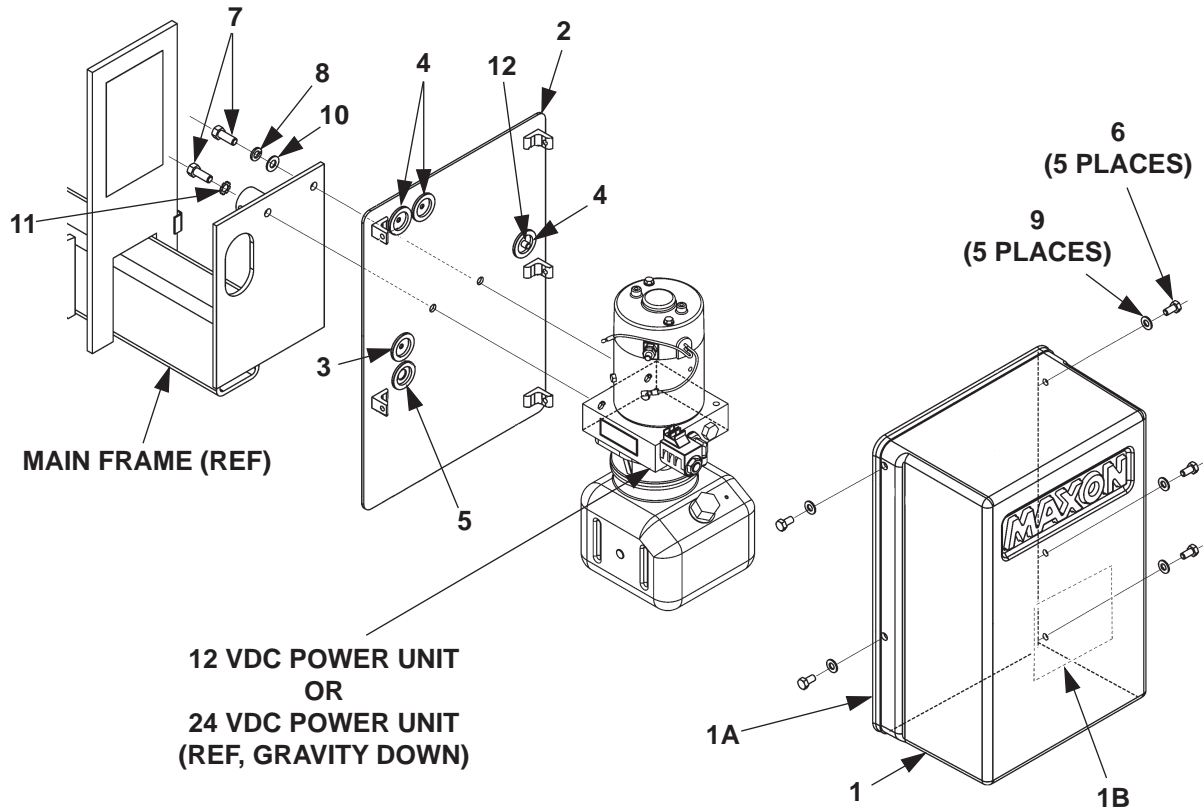

ITEM	QTY.	PART NO.	DESCRIPTION
REF	1	266406-01	PUMP ASSEMBLY, STANDARD TUK-A-WAY
		266406-02	PUMP ASSEMBLY, STANDARD TUK-A-WAY (24 VOLT)
1	1	266419-01	COVER ASSY
1A	1	093201-01	GASKET, RUBBER CHANNEL, 57-1/2" LG.
1B	1	261740	LABEL, OIL LEVEL
2	1	266427-01	PLATE, PUMP MOUNT
3	1	266428-01	GROMMET, 3/16" HOLE
4	3	266428-02	GROMMET, 1/4" HOLE
5	1	266428-06	GROMMET, 9/16" HOLE
6	5	900009-3	SCREW, CAP 5/16"-18 X 3/4" LG, GRADE 8
7	2	900014-4	SCREW, CAP 3/8"-16 X 1" LG, GRADE 8
8	1	902011-4	LOCK WASHER, 3/8"
9	5	902002-1	FLAT WASHER, 5/16"
10	1	902013-11	FLAT WASHER, 3/8"
11	1	903400-02	LOCK WASHER, EXTERNAL TOOTH, 3/8"
12	1	908022-02	PLUG, FLEXIBLE

MAXON[®]

11921 Slauson Ave. Santa Fe Springs, CA. 90670 (800) 227-4116 FAX (888) 771-7713

PUMP COVER & MOUNTING PLATE ASSEMBLY (POWER DOWN)

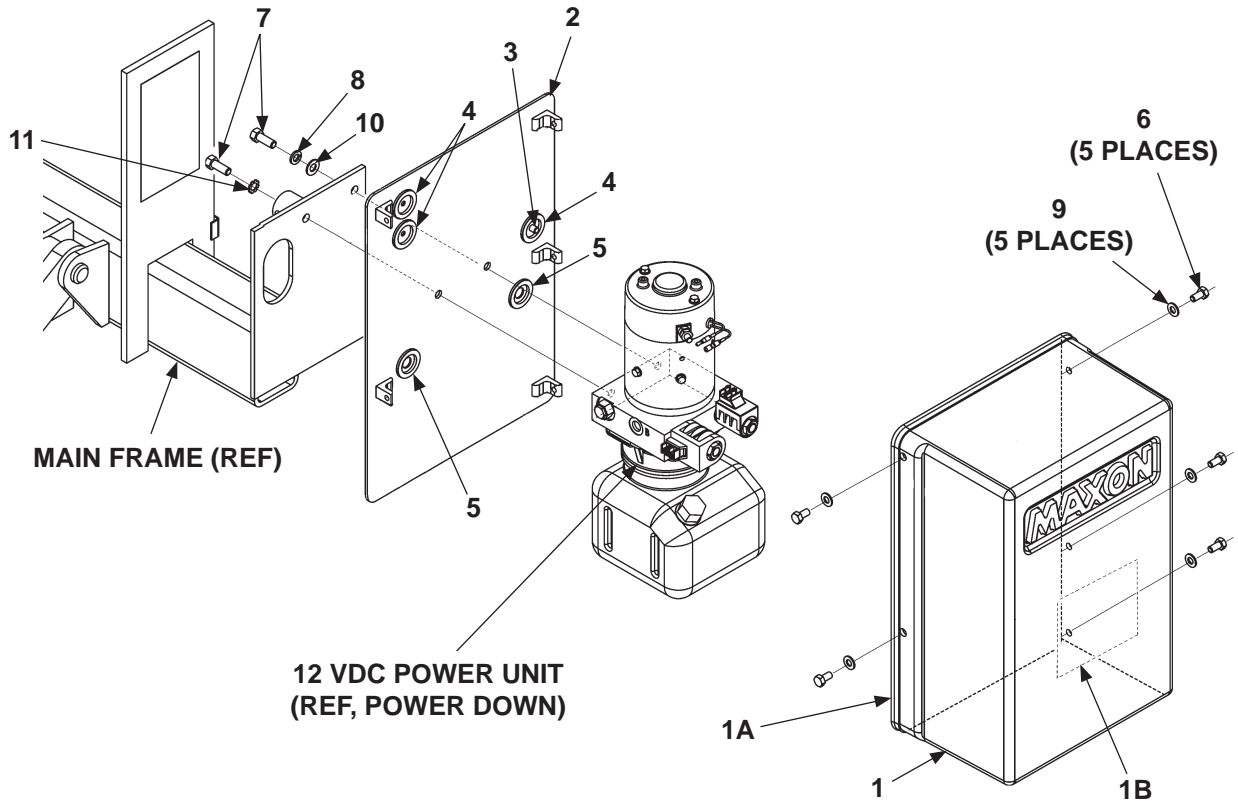

ITEM	QTY.	PART NO.	DESCRIPTION
REF	1	268180-01	PUMP ASSEMBLY, POWER DOWN TUK-A-WAY
1	1	266419-01	COVER ASSY
1A	1	093201-01	GASKET, RUBBER CHANNEL, 57-1/2" LG.
1B	1	261740	LABEL, OIL LEVEL
2	1	268179-01	PLATE, PUMP MOUNT
3	1	908022-02	PLUG, FLEXIBLE
4	3	266428-02	GROMMET, 1/4" HOLE
5	2	266428-06	GROMMET, 9/16" HOLE
6	5	900009-3	SCREW, CAP 5/16"-18 X 3/4" LG, GRADE 8
7	2	900014-4	SCREW, CAP 3/8"-16 X 1" LG, GRADE 8
8	1	902011-4	LOCK WASHER, 3/8"
9	5	902002-1	FLAT WASHER, 5/16"
10	1	902013-11	FLAT WASHER, 3/8"
11	1	903400-02	LOCK WASHER, EXTERNAL TOOTH, 3/8"

THIS PAGE INTENTIONALLY LEFT BLANK

MAXON[®]

11921 Slauson Ave. Santa Fe Springs, CA. 90670 (800) 227-4116 FAX (888) 771-7713

GRAVITY DOWN HYDRAULIC COMPONENTS

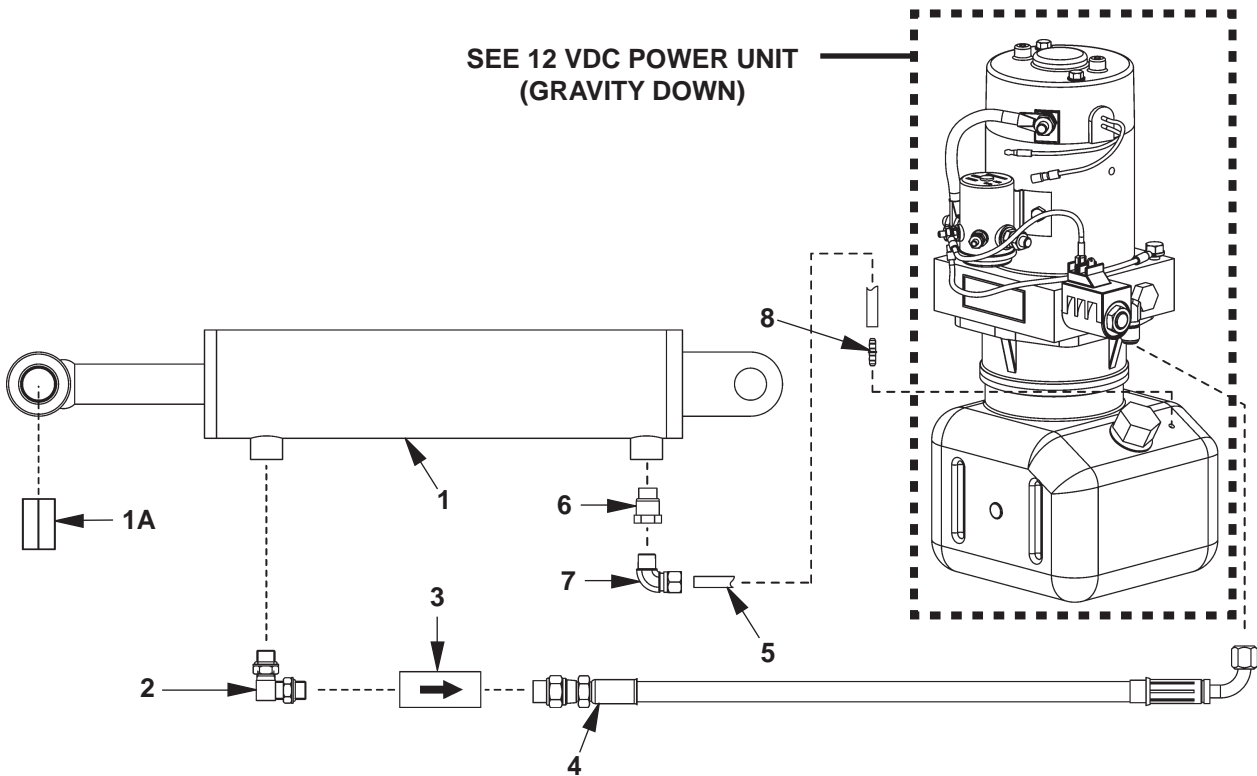

ITEM	QTY.	PART NO.	DESCRIPTION
1	1	266401-01	CYLINDER, 3" DIA X 10" STROKE (72-150)
		266401-02	CYLINDER, 3-1/2" DIA X 10" STROKE (TE-20)
1A	1	260916-03	BEARING, SELF LUBE
2	1	906722-01	ELBOW, 90 DEG O-RING, #6 M-M
3	1	906709-02	FLOW REGULATOR VALVE, 2 GPM
4	1	280635-01	HOSE ASSY, 3/8" HP, 54" LG.
5	1	224370-07	HOSE, PLASTIC 60-1/2" LG.
6	1	228012	ADAPTER, STRAIGHT THREAD, 9/16"-18 M - 1/4" F
7	1	202406	ELBOW, BRASS 1/4" x 1/4"
8	1	906728-01	DUAL BARBED FITTING, 1/64" I.D.

12 VDC POWER UNIT (GRAVITY DOWN)

CAUTION

To prevent damage to metal case starter solenoid, hold bottom terminal nut securely when loosening and tightening top terminal nut. Do not over-tighten the terminal nuts. For the 5/16" load terminals, torque nuts 35-40 lbs.-in. Torque the nuts on #10-32 control terminals 15-20 lbs.-in.

CAUTION

To prevent damage when installing 2-way valves, torque valve cartridge nut to 30 lbs.-in. max.

NOTE: MAXON recommends using dielectric grease on all electrical connections.

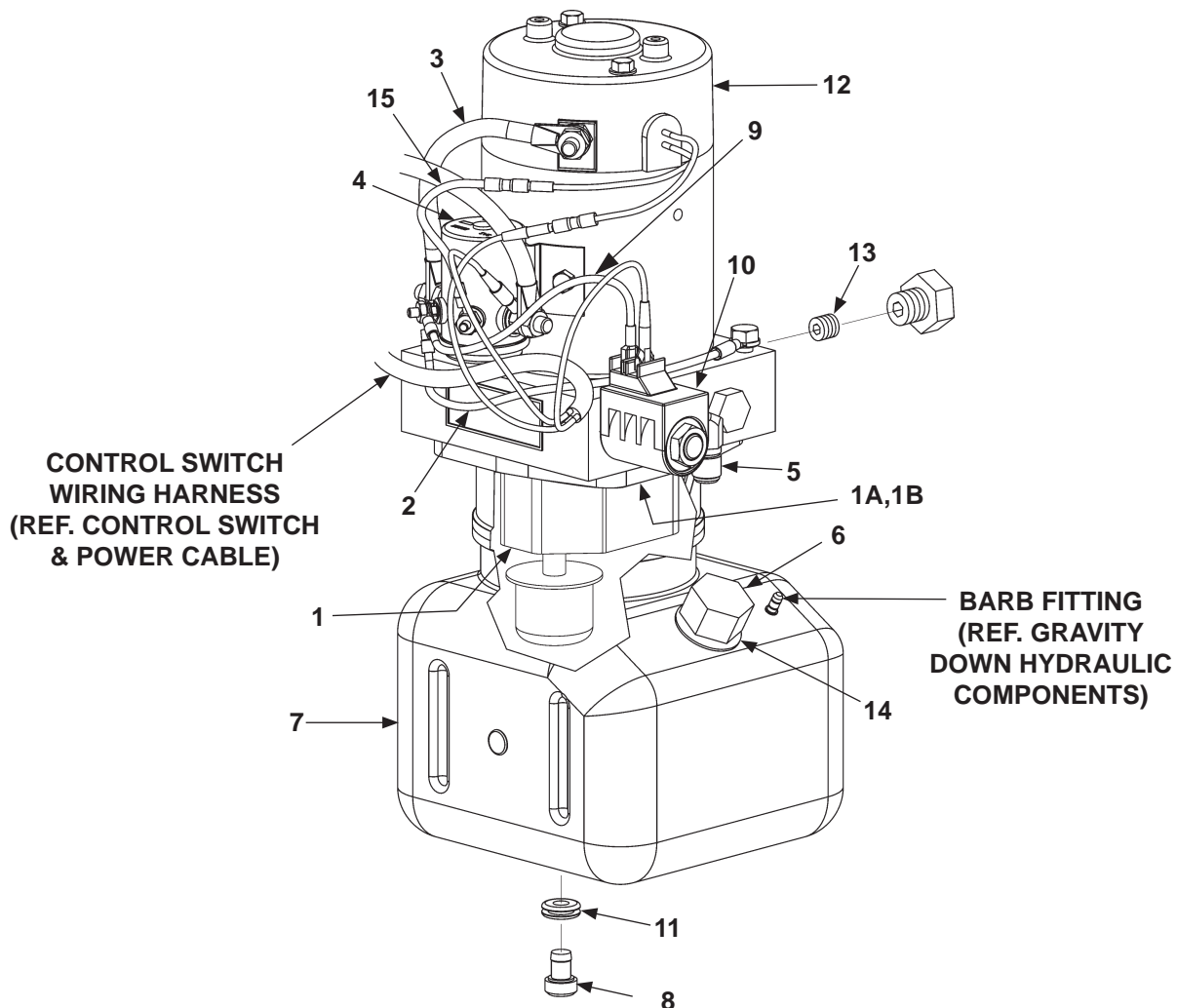

MAXON[®]

11921 Slauson Ave. Santa Fe Springs, CA. 90670 (800) 227-4116 FAX (888) 771-7713

ITEM	QTY.	PART NO.	DESCRIPTION
REF	1	268070-01	12 VDC POWER UNIT (GRAVITY DOWN)
1	1	290002	3-PIECE GEAR PUMP
1A	1	226594	OIL SEAL KIT
1B	1	290020	O-RING
2	1	268027-01	WIRE ASSEMBLY, 18 GA, #10 RING - 5/16" RING
3	1	280404	CABLE ASSEMBLY
4	1	268029-01	SOLENOID SWITCH
5	1	905152	ELBOW, 90 DEG, O-RING
6	1	280806-01	FILLER CAP
7	1	267733-11	RESERVOIR, 3 QT, VERTICAL WITH VENT
8	1	908017-01	DRAIN PLUG
9	1	280416	WIRE ASSEMBLY
10	1	290043	VALVE ASSEMBLY, 2 WAY
11	1	908018-01	GROMMET, 5/16" I.D.
12	1	280374	MOTOR, 12 VOLT DC
13	1	906740-01	RELIEF VALVE (RED SPRING)
14	1	908016-01	GROMMET, 3/4" I.D.
15	1	268024-01	WIRE ASSY, 16GA WHITE, 3" LG

24 VDC POWER UNIT (GRAVITY DOWN)

CAUTION

To prevent damage when installing 2-way valves, torque valve cartridge nut to 30 lbs.-in. max.

NOTE: MAXON recommends using dielectric grease on all electrical connections.

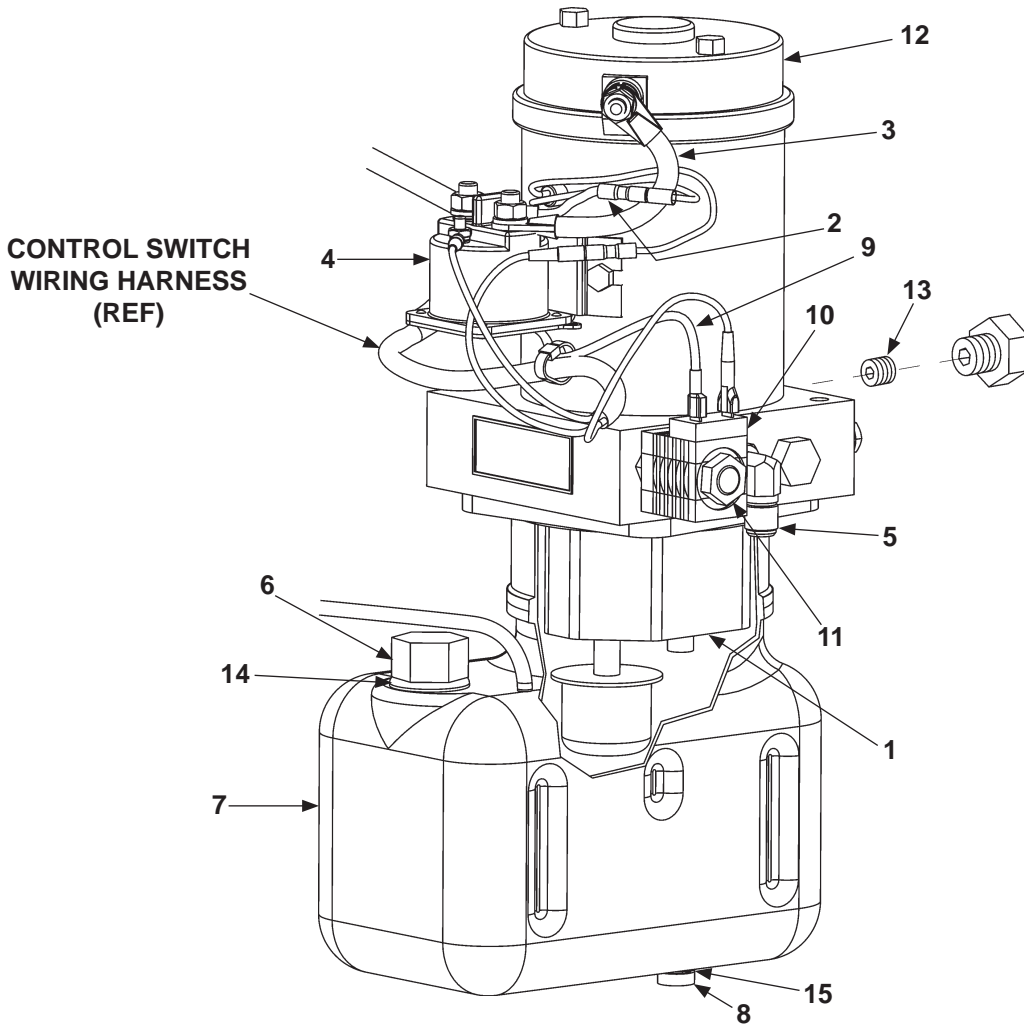

MAXON

11921 Slauson Ave. Santa Fe Springs, CA. 90670 (800) 227-4116 FAX (888) 771-7713

ITEM	QTY.	PART NO.	DESCRIPTION
REF	1	280610-24	24 VDC POWER UNIT (GRAVITY DOWN)
1	1	290065	3-PIECE GEAR PUMP
2	1	280566-01	WIRE ASSEMBLY, 16 GA, GREEN
3	1	280404	CABLE ASSEMBLY
4	1	281571-01	MOTOR STARTER SOLENOID, 24 VOLT DC
5	1	905152	90 DEG ELBOW
6	1	280806-01	FILLER CAP
7	1	280589-01	RESERVOIR
8	1	908017-01	DRAIN PLUG
9	1	280416	WIRE ASSEMBLY
10	1	281572-01	24 VDC COIL
11	1	906719-01	VALVE
12	1	281573-01	MOTOR, 24 VOLT DC
13	1	906737-01	RELIEF VALVE
14	1	908016-01	GROMMET, 19/32"
15	1	908018-01	GROMMET, 5/16"

MAXON[®] 11921 Slauson Ave. Santa Fe Springs, CA. 90670 (800) 227-4116 FAX (888) 771-7713

MAXON®

11921 Slauson Ave. Santa Fe Springs, CA. 90670 (800) 227-4116 FAX (888) 771-7713

THIS PAGE INTENTIONALLY LEFT BLANK

POWER DOWN HYDRAULIC COMPONENTS

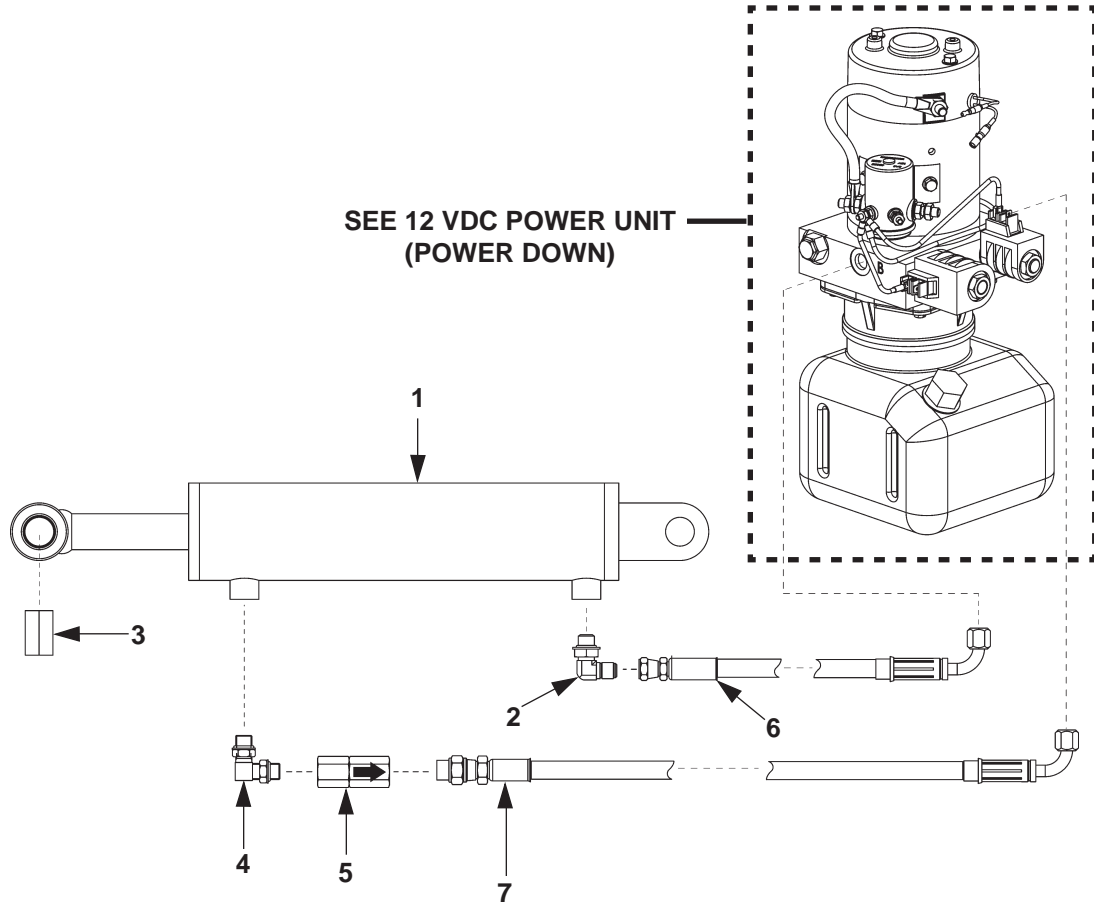

ITEM	QTY.	PART NO.	DESCRIPTION
1	1	266401-01	CYLINDER, 3" DIA X 10" STROKE (72-150)
		266401-02	CYLINDER, 3-1/2" DIA X 10" STROKE (TE-20)
2	1	905152	ELBOW, 90 DEG SAE #6-JIC37 #6
3	1	260916-03	BEARING, SELF LUBE
4	1	906722-01	ELBOW, 90 DEG, O-RING, #6 M-M
5	1	906709-02	FLOW REGULATOR VALVE, 2 GPM
6	1	280634-01	HOSE ASSEMBLY, 3/8"HP, 50"LG.
7	1	280635-01	HOSE ASSEMBLY, 3/8"HP, 54"LG.

12 VDC POWER UNIT (POWER DOWN)

CAUTION

To prevent damage to plastic case starter solenoid, do not over-tighten the terminal nuts. For the 5/16" load terminals, torque nuts 35-40 lbs.-in. Torque the nuts on #10-32 control terminals 15-20 lbs.-in.

CAUTION

To prevent damage when installing 2-way valves, torque valve cartridge nut to 30 lbs.-in. max.

NOTE: MAXON recommends using dielectric grease on all electrical connections.

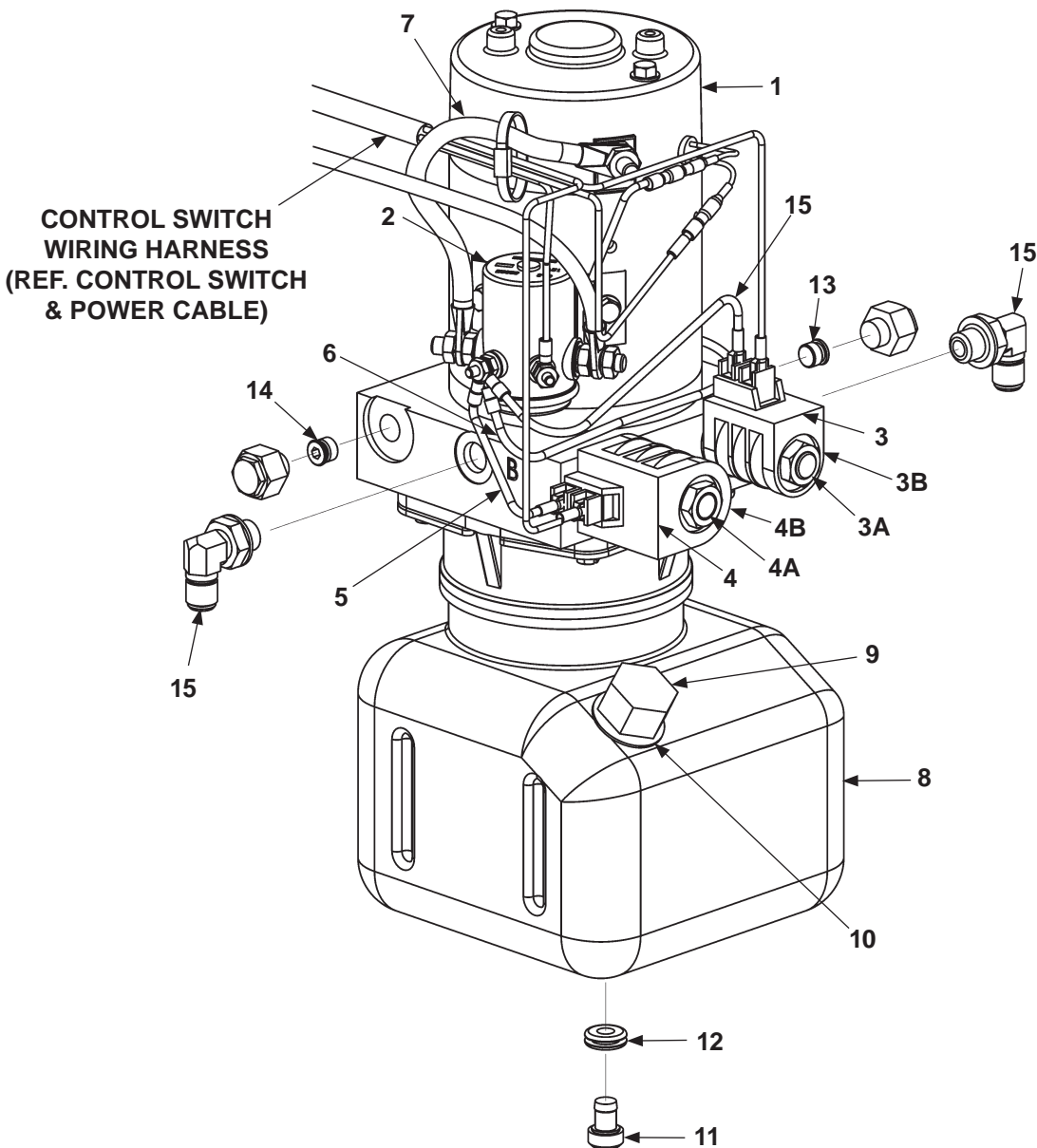

ITEM	QTY	PART NO.	DESCRIPTION
REF	1	268181-01	12 VDC POWER UNIT (POWER DOWN)
1	1	268176-01	MOTOR, 12 VDC
2	1	268029-01	SWITCH, SOLENOID
3	1	906821-01	2P2W VALVE & COIL ASSEMBLY, 4 WAY, DOUBLE SPADE
3A	1	906822-01	2P2W VALVE
3B	1	290045	COIL, DOUBLE SPADE, 2 WAY
4	1	290046	VALVE ASSEMBLY, 4 WAY, DOUBLE SPADE
4A	1	290047	VALVE CARTRIDGE, 4 WAY
4B	1	290048	COIL, DOUBLE SPADE, 3 OR 4 WAY
5	2	280416	WIRE ASSEMBLY
6	1	268079-01	WIRE ASSEMBLY, 18 GA, #10 RING - 5/16" RING
7	1	280404	CABLE ASSEMBLY
8	1	267733-01	RESERVOIR, 3 QT, VERTICAL WITH VENT
9	1	280806-01	FILLER CAP
10	1	908016-01	GROMMET, 3/4" I.D.
11	1	908017-01	DRAIN PLUG
12	1	908018-01	GROMMET, 5/16" I.D.
13	1	906738-02	RELIEF VALVE, ADJUST, 3200PSI
14	1	268174-01	RELIEF VALVE, ADJUST, 1100PSI
15	2	905152	ELBOW, 90 DEG, O-RING

DECALS

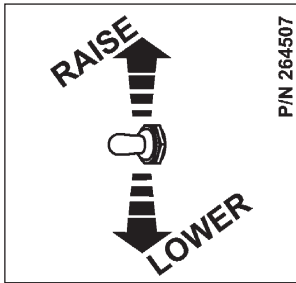

RAISE/LOWER DECAL
P/N 264507

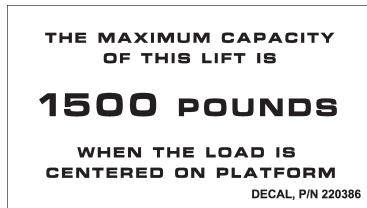

CAPACITY DECAL (72-150 ONLY)
P/N 220386

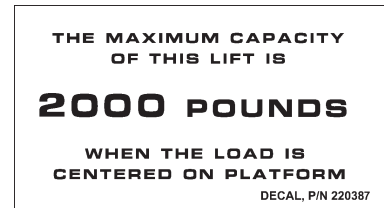

CAPACITY DECAL (TE-20 ONLY)
P/N 220387

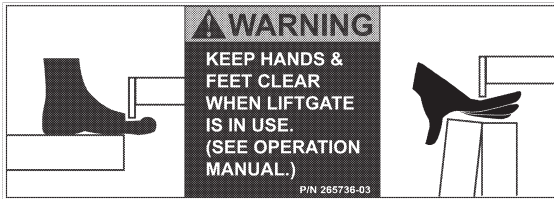

WARNING DECAL (2 PLACES, LH SIDE NOT SHOWN)
P/N 265736-03

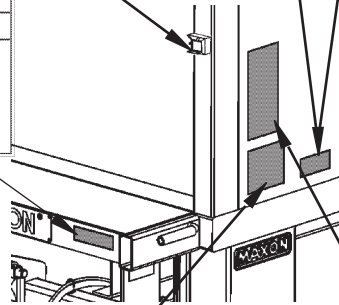

WARNING

READ THIS INFORMATION CAREFULLY

- Improper operation of this Liftgate can result in serious personal injury. Do not operate unless you have been properly instructed and have read, and are familiar with the operating instructions. If you do not have a copy of the instructions, please obtain them from your employer, distributor, or lessor before you attempt to operate Liftgate.
- Be certain that the vehicle is properly and securely braked before using the Liftgate.
- Always inspect this Liftgate for maintenance or damage before using it. If there are signs of improper maintenance, damage to vital parts, or slippery Platform surface, do not use the Liftgate until these problems have been corrected.
- Do not overload the Liftgate. The load limit is based on evenly distributed cargo over the entire Platform surface. If you are using a pallet jack, be sure it can be maneuvered safely. Do not operate a forklift on the Platform or travel with the platform in an open position at any time.
- Load should be placed in a stable position close to the edge of the Platform nearest the truck. The heaviest portion of the load should never be placed beyond the center of the Platform away from the truck.
- Never allow yourself, a helper, or bystander to stand in a position where a falling load could land on either of you. Also do not allow any part of yours or your helper's body to be placed under, within, or around any portion of the moving Liftgate, or its mechanisms, or in a position that would trap them between the platform and the ground or truck when the Liftgate is operated.
- If a helper is riding the Platform with you, make sure you are both doing so safely and that you are not in danger of coming in contact with any moving or potentially moving obstacles. USE GOOD COMMON SENSE. If load appears to be unsafe, do not lift or lower it.

For a free copy of other manuals that pertain to this model Liftgate, please visit our website at www.maxonlift.com or call Customer Service at (800) 227-4116.

MAXON LIFT CORP.PART NO. 264081

WARNING DECAL
P/N 264081

OPERATING INSTRUCTIONS

A. DEPRESS CONTROL HANDLE
B. PUSH CONTROL SWITCH

1 MUST TOUCH GROUND

USE HANDLE UNDER PLATFORM TO OPEN THE PLATFORM.

2

UNFOLD FLIPOVER.

3

4

5 TO TUCK UNIT AWAY REVERSE STEPS 1, 2, 3, & 4. STOW LIFTGATE UNDER HYDRAULIC PRESSURE.

DECAL, P/N 251867-06

INSTRUCTION DECAL
P/N 251867-06

FIG. 40-1

CONTROL SWITCH AND POWER CABLE

NOTE: Use switch to **RAISE** and **LOWER** Liftgate to make sure switch operates as shown on the decal.

NOTE: MAXON recommends using dielectric grease on all electrical connections.

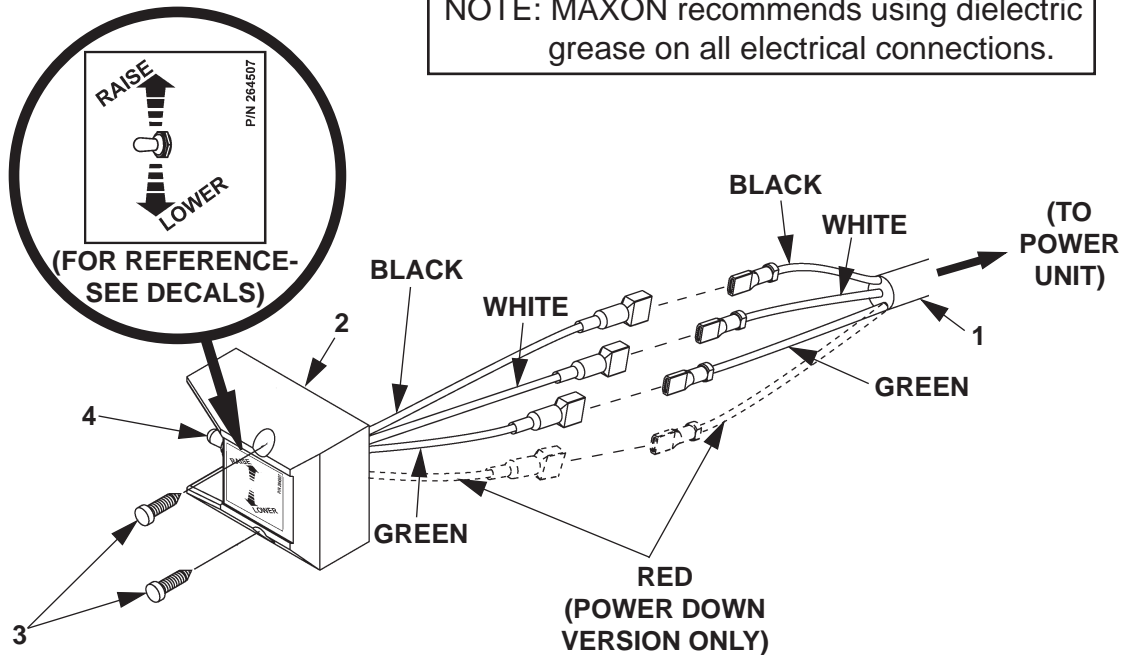

ITEM	QTY.	PART NO.	DESCRIPTION
1	1	268025-01	CABLE ASSEMBLY, 85" LG (12 VDC GRAVITY DOWN)
		280637-01	CABLE ASSEMBLY, 84" LG (24 VDC GRAVITY DOWN)
		268170-01	CABLE ASSEMBLY, 85" LG (POWER DOWN)
2	1	267959-01	MOLDED SWITCH ASSEMBLY (GRAVITY DOWN)
		264951-04	MOLDED SWITCH ASSEMBLY (POWER DOWN)
3	2	900057-5	SCREW, SELF-TAPPING #10-24 X 1" LG.
4	1	905206	SWITCH BOOT SEAL
5	1	264422	CABLE ASSEMBLY, 175 AMPS, 38' LG
6	1	264687	KIT, MEGAFUSE (175 AMP FUSE & HEATSHRINK TUBING)

SHORT END TO VEHICLE BATTERY

⚠ WARNING
Do not attach cable to battery until Liftgate repairs are completed.

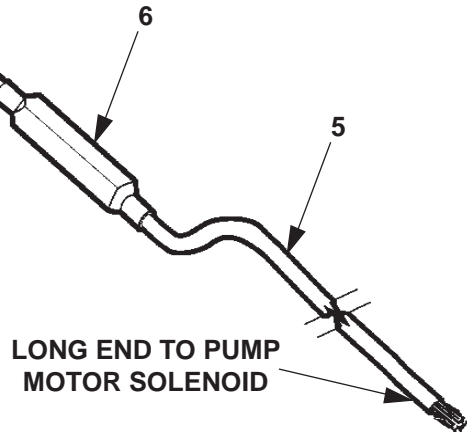

MAXON 11921 Slauson Ave. Santa Fe Springs, CA. 90670 (800) 227-4116 FAX (888) 771-7713

HYDRAULIC SYSTEM DIAGRAMS

HYDRAULIC SCHEMATIC (GRAVITY DOWN)

MAXON[®]

11921 Slauson Ave. Santa Fe Springs, CA. 90670 (800) 227-4116 FAX (888) 771-7713

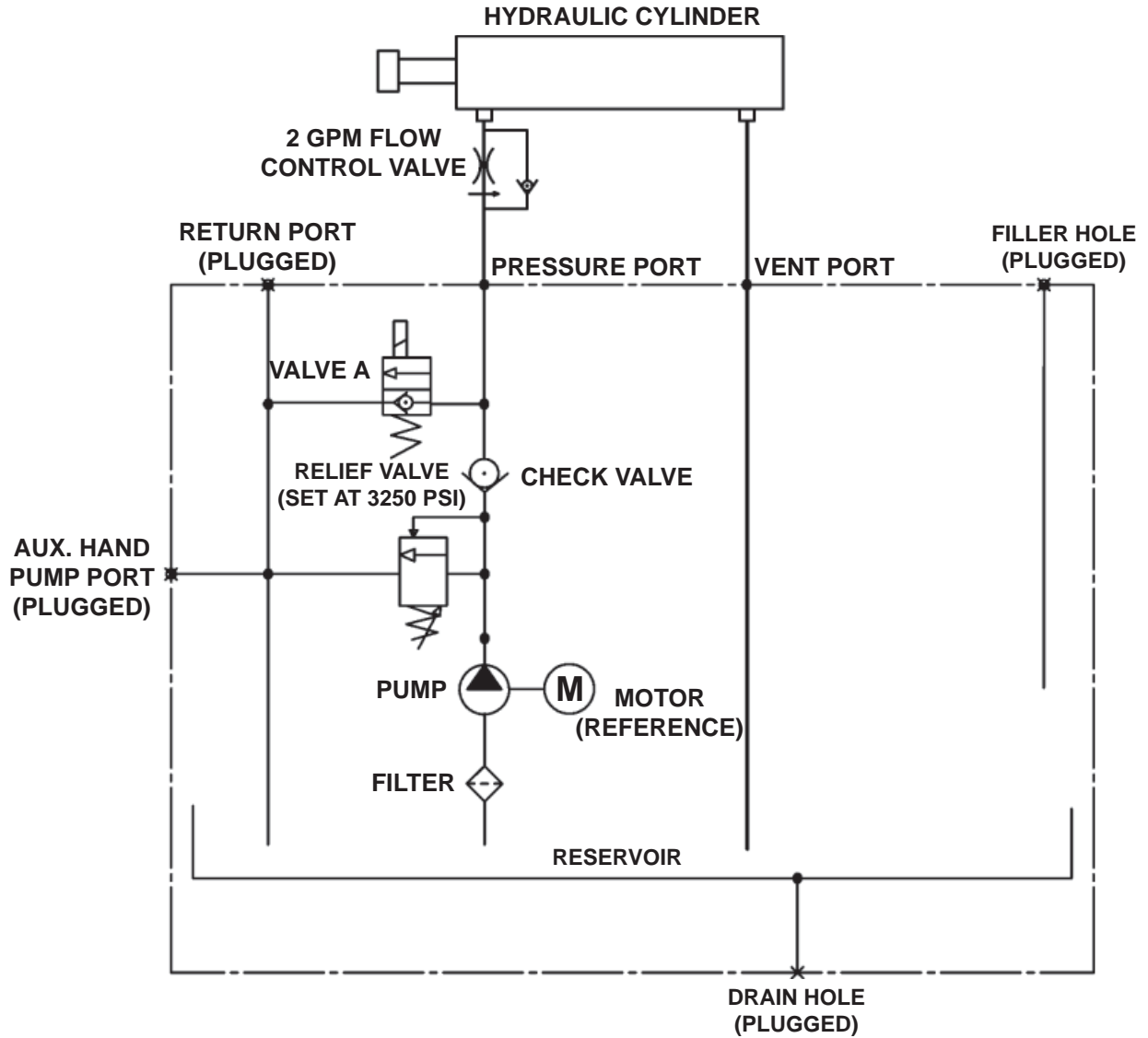

HYDRAULIC SCHEMATIC (POWER DOWN)

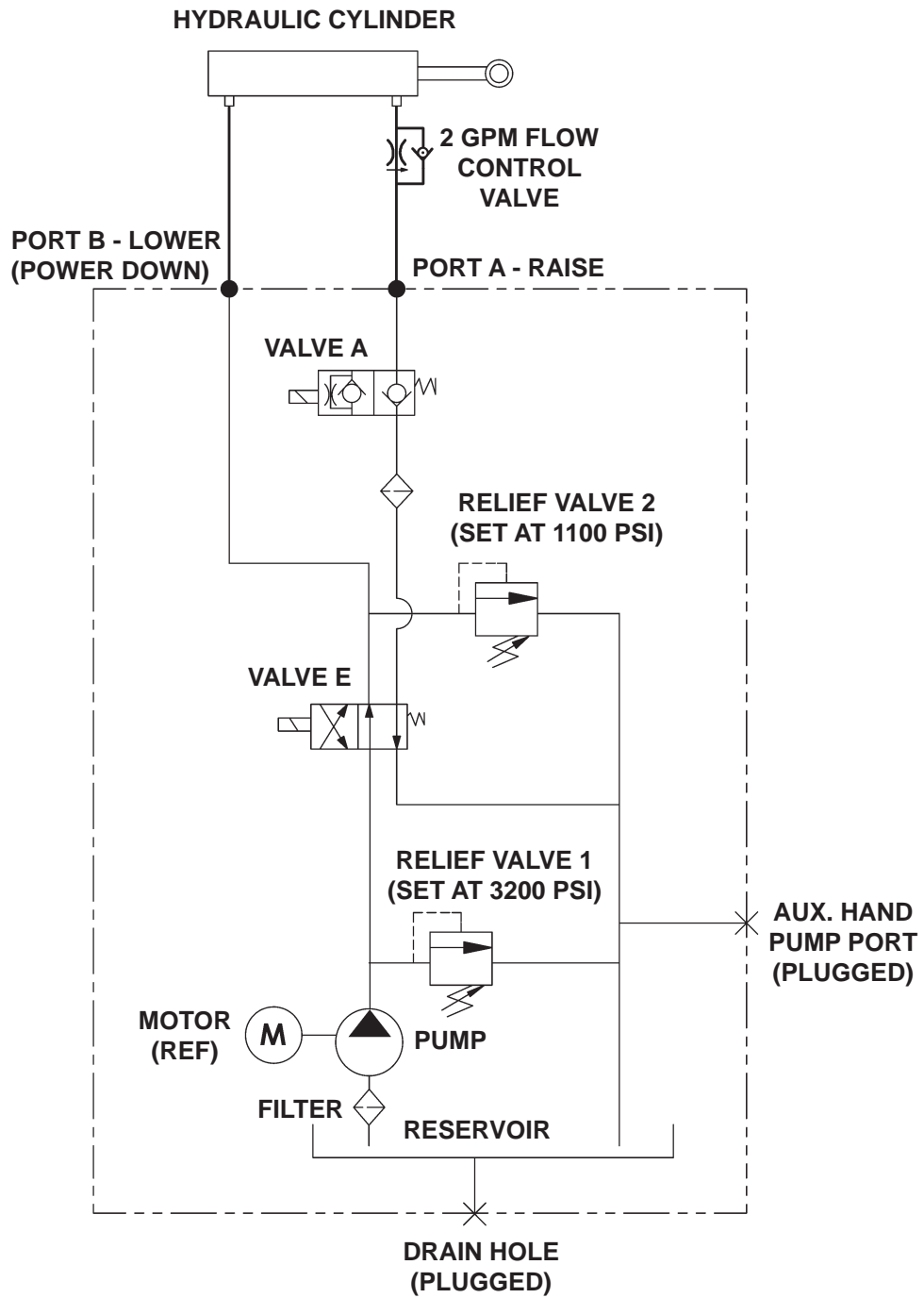

ELECTRICAL SYSTEM DIAGRAMS

ELECTRICAL SCHEMATIC (GRAVITY DOWN)

MAXON[®]

11921 Slauson Ave. Santa Fe Springs, CA. 90670 (800) 227-4116 FAX (888) 771-7713

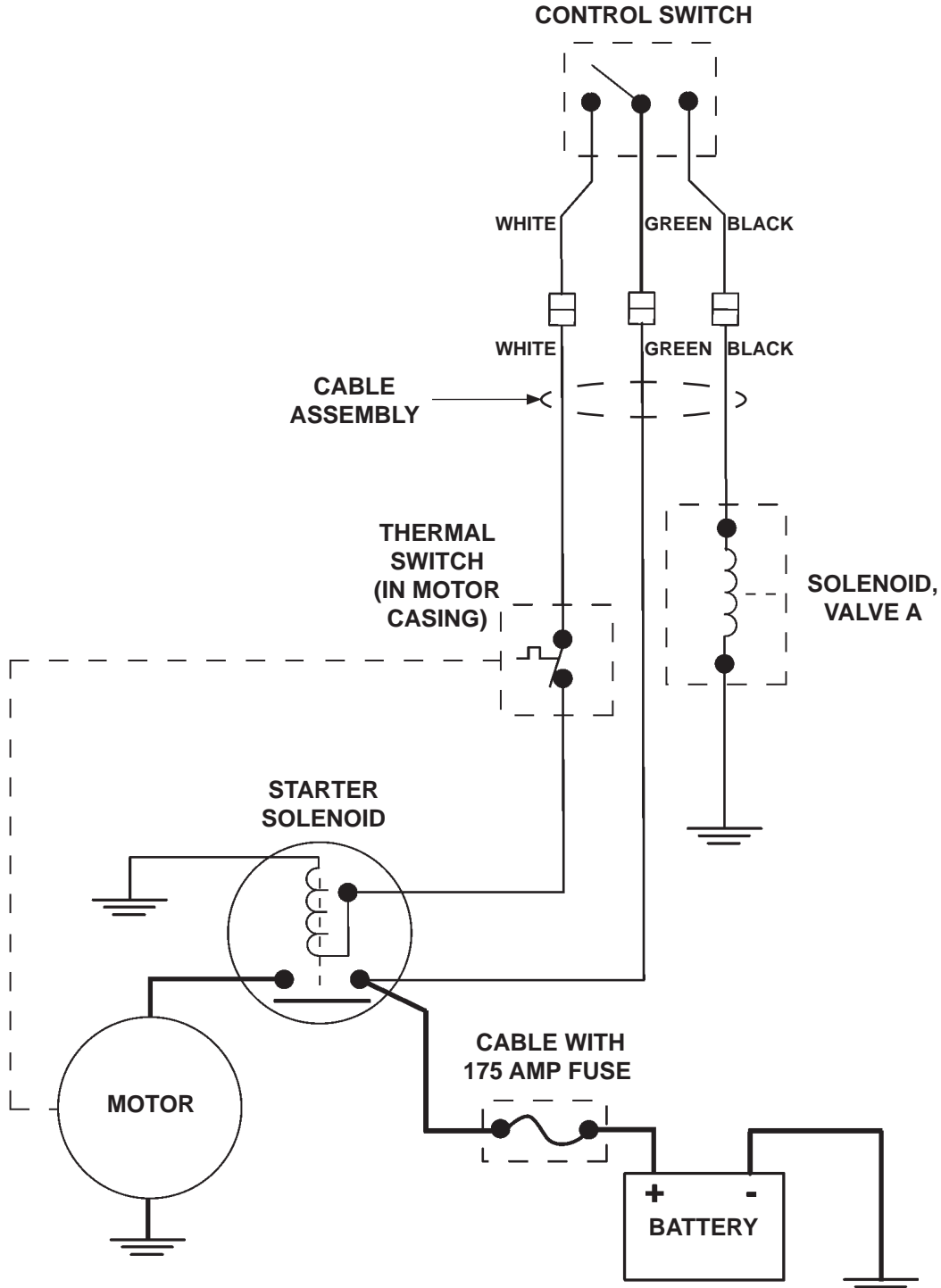

ELECTRICAL SCHEMATIC (POWER DOWN)

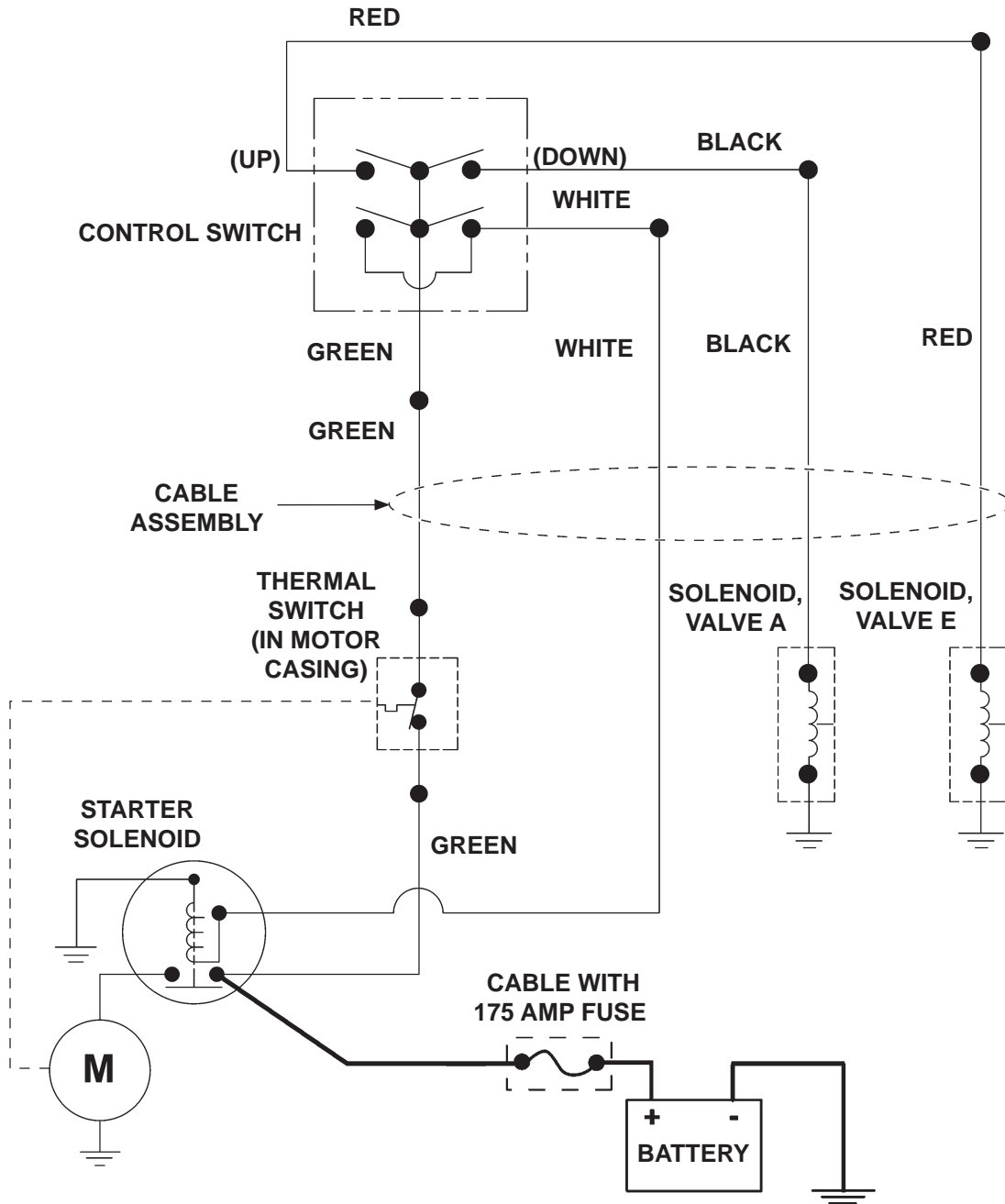

TROUBLESHOOTING

PLATFORM WILL NOT RAISE

1. Use voltmeter to verify power is being supplied to solenoid terminal "B" (FIG. 46-1). Recharge the battery if there is less than 12.6 volts.

CAUTION

Keep dirt, water and other contaminants from entering the hydraulic system. Before opening the hydraulic fluid reservoir filler cap, drain plug and hydraulic lines, clean up contaminants that can get in the openings. Also, protect the openings from accidental contamination during maintenance.

2. See the **CHECKING HYDRAULIC FLUID** procedure. If necessary, add hydraulic fluid.
3. Touch a jumper wire to terminals "B" & "D" (FIG. 46-1). If motor runs, check switch, switch connections, and white wire. Check and correct wiring connections or replace the switch.
4. Touch heavy jumper cables to terminals "A" & "B" (FIG. 46-1).
 - a. If motor runs, replace the motor solenoid.
 - b. If motor does not run, repair or replace the pump motor.

NOTE: In most cases, you can avoid having to manually bleed hydraulic system by correctly positioning Liftgate platform before disconnecting any lifting cylinder high pressure hydraulic lines. The following procedure can save time and prevent accidental fluid spills and hazards.

5. Check for structural damage and replace worn parts.
6. Check filter in the pump reservoir. Replace filter if necessary.
7. Check for dirty pump motor relief valve. Clean if necessary. Replace any worn out relief valve parts.

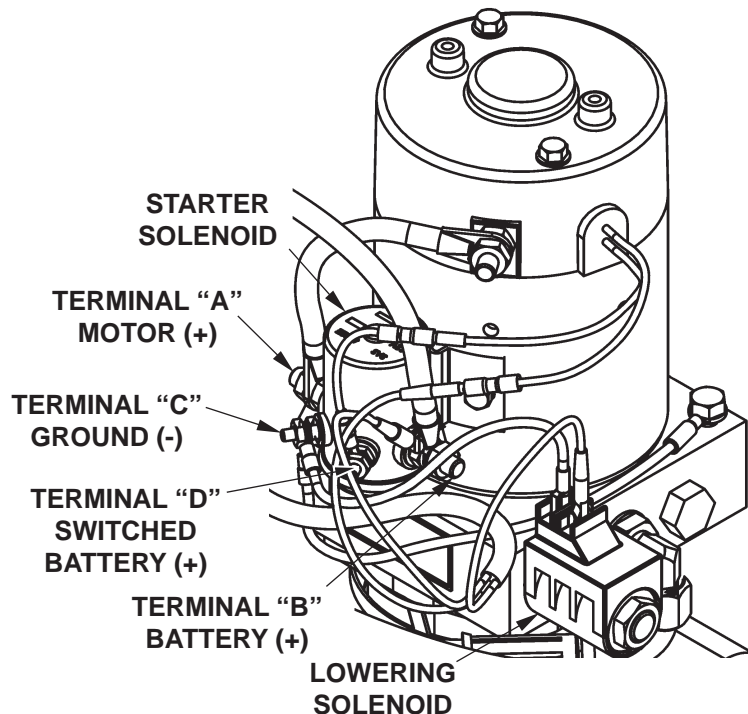

FIG. 46-1

PLATFORM RAISES BUT LEAKS DOWN

1. Check if solenoid valves are constantly energized by touching a screwdriver to the top nut of the solenoid (**FIG. 47-1**). Try pulling the screwdriver away from the solenoid. If the solenoid nut attracts the screwdriver (magnetically) without pushing the toggle switch, the control circuit is operating incorrectly. Check if toggle switch, wiring or coil are faulty.

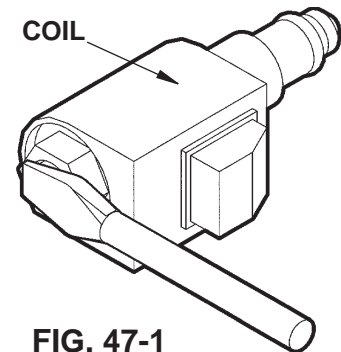

FIG. 47-1

CAUTION

Keep dirt, water and other contaminants from entering the hydraulic system. Before opening the hydraulic fluid reservoir filler cap, drain plug and hydraulic lines, clean up contaminants that can get in the openings. Also, protect the openings from accidental contamination during maintenance.

NOTE: In most cases, you can avoid having to manually bleed hydraulic system by correctly positioning Liftgate platform before disconnecting any lifting cylinder high pressure hydraulic lines. The following procedure can save time and prevent accidental fluid spills and hazards.

2. Check the valve stem by removing the coil assembly (**Item 1, FIG. 47-2**). With platform on ground, unscrew the valve stem (**Item 2, FIG. 47-2**) from the pump. Push on the plunger that is located inside the valve stem by inserting a small screwdriver blade in the end. If the plunger does not move freely, (approximately 1/8") replace the valve stem. **When reinstalling valve stem, torque hex nut to 30 in-lbs.**

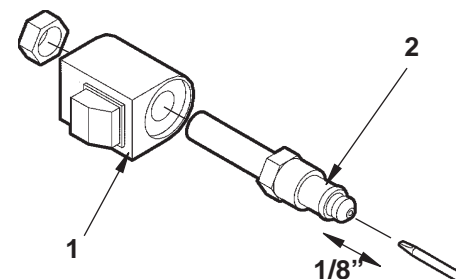

FIG. 47-2

3. Check the hydraulic cylinder. With the platform on the ground, remove the hydraulic line from the vent/down port of the cylinder (**FIG. 47-3**). Raise the platform even with the bed. Allow pump motor to run two seconds more while you watch for hydraulic fluid at the vent/down port. A few drops of hydraulic fluid escaping the vent/down port is normal; however, if it streams from the vent/down port, piston seals are worn. Replace seals.

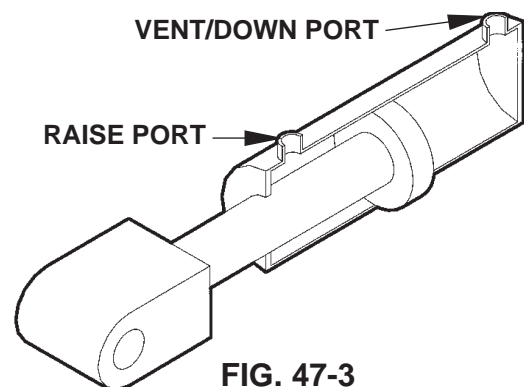

FIG. 47-3

TROUBLESHOOTING

PLATFORM RAISES PARTIALLY AND STOPS

CAUTION

Keep dirt, water and other contaminants from entering the hydraulic system. Before opening the hydraulic fluid reservoir filler cap, drain plug and hydraulic lines, clean up contaminants that can get in the openings. Also, protect the openings from accidental contamination during maintenance.

1. See the **CHECKING HYDRAULIC FLUID** procedure. If necessary, add hydraulic fluid.
2. Use voltmeter to verify the battery shows 12.6 volts or more.
3. Check for structural damage and poor lubrication. Replace worn parts.

NOTE: In most cases, you can avoid having to bleed the hydraulic system by correctly positioning Liftgate platform before opening hydraulic lines. Refer to following procedure. Save time on the job and prevent accidental fluid spills and hazards.

4. Check the hydraulic cylinder. With the platform on the ground, remove the breather plug or vent line from the vent/down port of the cylinder (**FIG. 48-1**). Raise the platform even with the bed. Allow pump motor to run two seconds more while you watch for hydraulic fluid at the vent/down port. A few drops of hydraulic fluid escaping the vent/down port is normal; however, if it streams from the vent/down port, piston seals are worn. Replace seals.
5. Check filter in the pump reservoir. Replace filter if necessary.
6. Check for dirty pump motor relief valve. Clean if necessary. Replace any worn out relief valve parts.

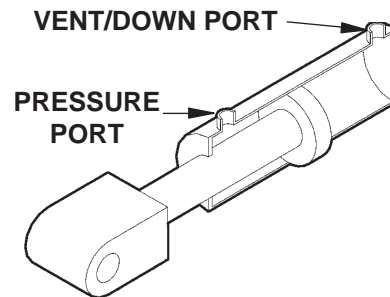

FIG. 48-1

MAXON[®]

11921 Slauson Ave. Santa Fe Springs, CA. 90670 (800) 227-4116 FAX (888) 771-7713

LIFTGATE WILL NOT LIFT RATED CAPACITY

1. Use voltmeter to verify the battery shows 12.6 volts or more under load from pump motor.
2. Check for structural damage and lack of lubrication. Replace worn parts.

CAUTION

Keep dirt, water and other contaminants from entering the hydraulic system. Before opening the hydraulic fluid reservoir filler cap, drain plug and hydraulic lines, clean up contaminants that can get in the openings. Also, protect the openings from accidental contamination during maintenance.

NOTE: In most cases, you can avoid having to bleed the hydraulic system by correctly positioning Liftgate platform before opening hydraulic lines. Refer to following procedure. Save time on the job and prevent accidental fluid spills and hazards.

3. With platform on the ground, remove the pressure hose and fitting from the pump and replace it with a 0-4000 PSI pressure gauge. Hold the switch in the "UP" position. Adjust the relief valve on the side of the pump until the gauge shows 3250 PSI (**FIG. 49-2**). Remove gauge and reinstall pressure hose.
4. Check for dirty pump motor relief valve. Clean if necessary. Replace any worn out relief valve parts.
5. Check the hydraulic cylinder. With the platform on the ground, remove the breather plug or vent line from the vent/down port of the cylinder (**FIG. 49-1**). Raise the platform even with the bed. Allow pump motor to run two seconds more while you watch for hydraulic fluid at the vent/down port. A few drops of hydraulic fluid escaping the vent/down port is normal; however, if it streams from the vent/down port, piston seals are worn. Replace seals.
6. If pump cannot produce 3250 PSI can't lift load capacity with a minimum of 12.6 volts available, the pump is worn and needs to be replaced.

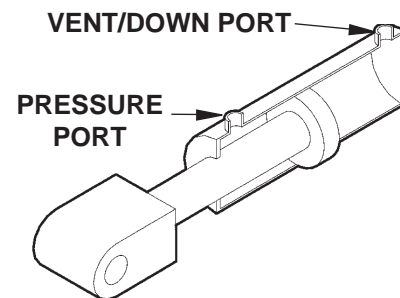

FIG. 49-1

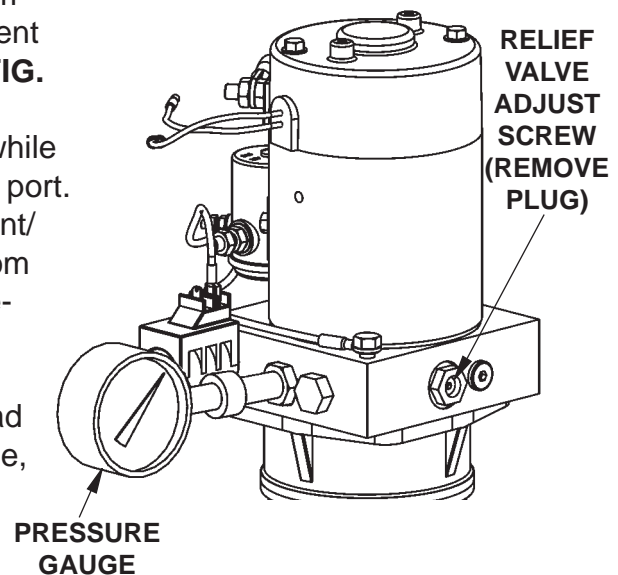

FIG. 49-2

TROUBLESHOOTING PLATFORM RAISES SLOWLY

1. Use voltmeter to verify power is being supplied to solenoid terminal "B". Recharge the battery if voltmeter indicates less than 12.6 volts (FIG. 50-1).

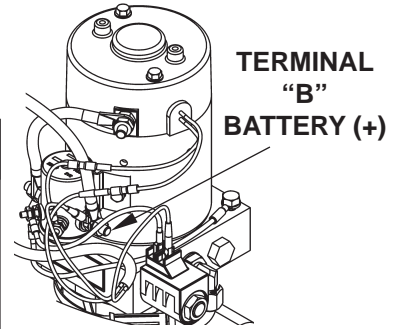

FIG. 50-1

CAUTION

Keep dirt, water and other contaminants from entering the hydraulic system. Before opening the hydraulic fluid reservoir filler cap, drain plug and hydraulic lines, clean up contaminants that can get in the openings. Also, protect the openings from accidental contamination during maintenance.

2. Check the hydraulic cylinder. With the platform on the ground, remove the breather plug or vent line from the vent/down port of the cylinder (FIG. 50-3). Raise the platform even with the bed. Allow pump motor to run two seconds more while you watch for hydraulic fluid at the vent/down port. A few drops of hydraulic fluid escaping the vent/down port is normal; however, if it streams from the vent/down port, piston seals are worn. Replace seals.

NOTE: In most cases, you can avoid having to bleed the hydraulic system by correctly positioning Liftgate platform before opening hydraulic lines. Refer to following procedure. Save time on the job and prevent accidental fluid spills and hazards.

3. Check and clean flow control valve in high pressure hydraulic line attached to cylinder. When installing flow control valve, make sure arrow on valve is oriented as shown in FIG. 50-3.

4. See the **CHECKING HYDRAULIC FLUID** procedure. If necessary, add hydraulic fluid.

5. Verify the pump motor is grounded to the vehicle frame.

6. Check for leaking hoses and fittings. Tighten or replace as required.

7. Check for structural damage or poor lubrication. Replace worn parts.

8. Check the filter in the pump reservoir. Replace if necessary.

9. With platform on the ground, remove the pressure hose and fitting from the pump and replace it with a 0-4000 PSI pressure gauge. Hold the control switch in the "RAISE" position. Adjust the relief valve on the side of the pump until the gauge shows 3250 PSI (FIG. 50-2). Remove gauge and reinstall pressure hose.

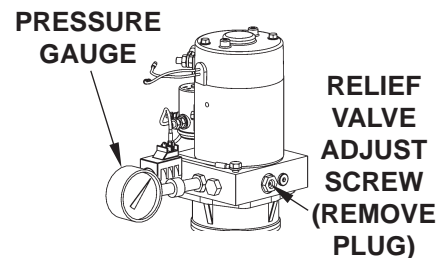

FIG. 50-2

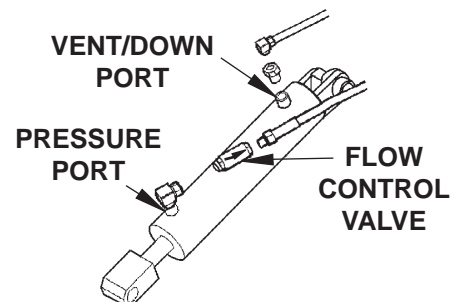

FIG. 50-3

PLATFORM WILL NOT LOWER, LOWERS TOO SLOWLY OR TOO QUICKLY

1. Use voltmeter to verify power is being supplied to solenoid terminal "B". Recharge the battery if voltmeter displays less than 12.6 volts (**FIG. 51-1**).
2. Check for structural damage or poor lubrication. Replace worn parts.
3. Check if solenoid valve is getting power by holding a screwdriver against the top nut of the solenoid. Push control switch to "**LOWER**" position to energize solenoid (**FIG. 51-2**). A good solenoid will attract (magnetically) the screwdriver to the nut and make it difficult to pull the screwdriver away from the nut.

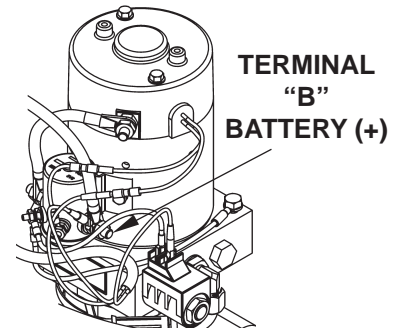

FIG. 51-1

CAUTION

Keep dirt, water and other contaminants from entering the hydraulic system. Before opening the hydraulic fluid reservoir filler cap, drain plug and hydraulic lines, clean up contaminants that can get in the openings. Also, protect the openings from accidental contamination during maintenance.

NOTE: In most cases, you can avoid having to bleed the hydraulic system by correctly positioning Liftgate platform before opening hydraulic lines. Refer to following procedure. Save time on the job and prevent accidental fluid spills and hazards.

4. Check the valve stem by removing the coil assembly (**Item 1, FIG. 51-2**). With platform supported, unscrew the valve stem (**Item 2, FIG. 51-2**) from the pump. Push on the plunger located inside the valve stem by inserting a small screwdriver blade in the end. If the plunger does not move freely (approximately 1/8"), replace the valve stem.
5. Check if filtering screen on solenoid valve is plugged. Clean carefully if required.
6. Check and clean flow control valve in high pressure hydraulic line attached to cylinder.
7. Check if flow control valve (**FIG. 51-3**) is pointing to the direction of restricted fluid flow (back toward pump). If required, remove flow control valve and install it correctly (**FIG. 51-3**).

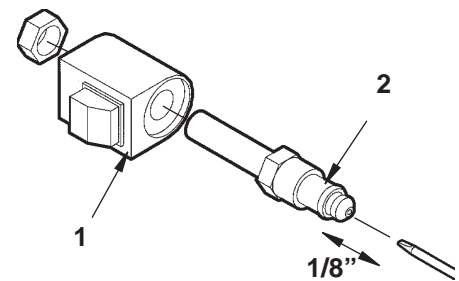

FIG. 51-2

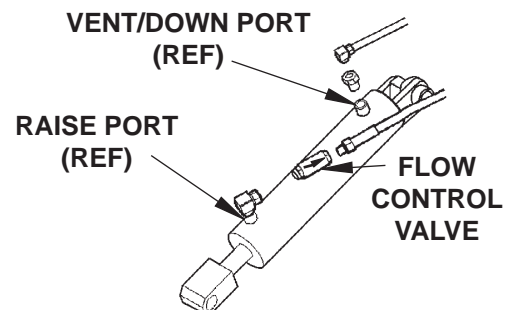

FIG. 51-3

