

M-04-04
REV. C
APRIL 2006

MAXON®

MAINTENANCE MANUAL

GPTLR-25, GPTLR-33, GPTLR-44, & GPTLR-55

TUK-A-WAY®
LIFT GATE SERIES

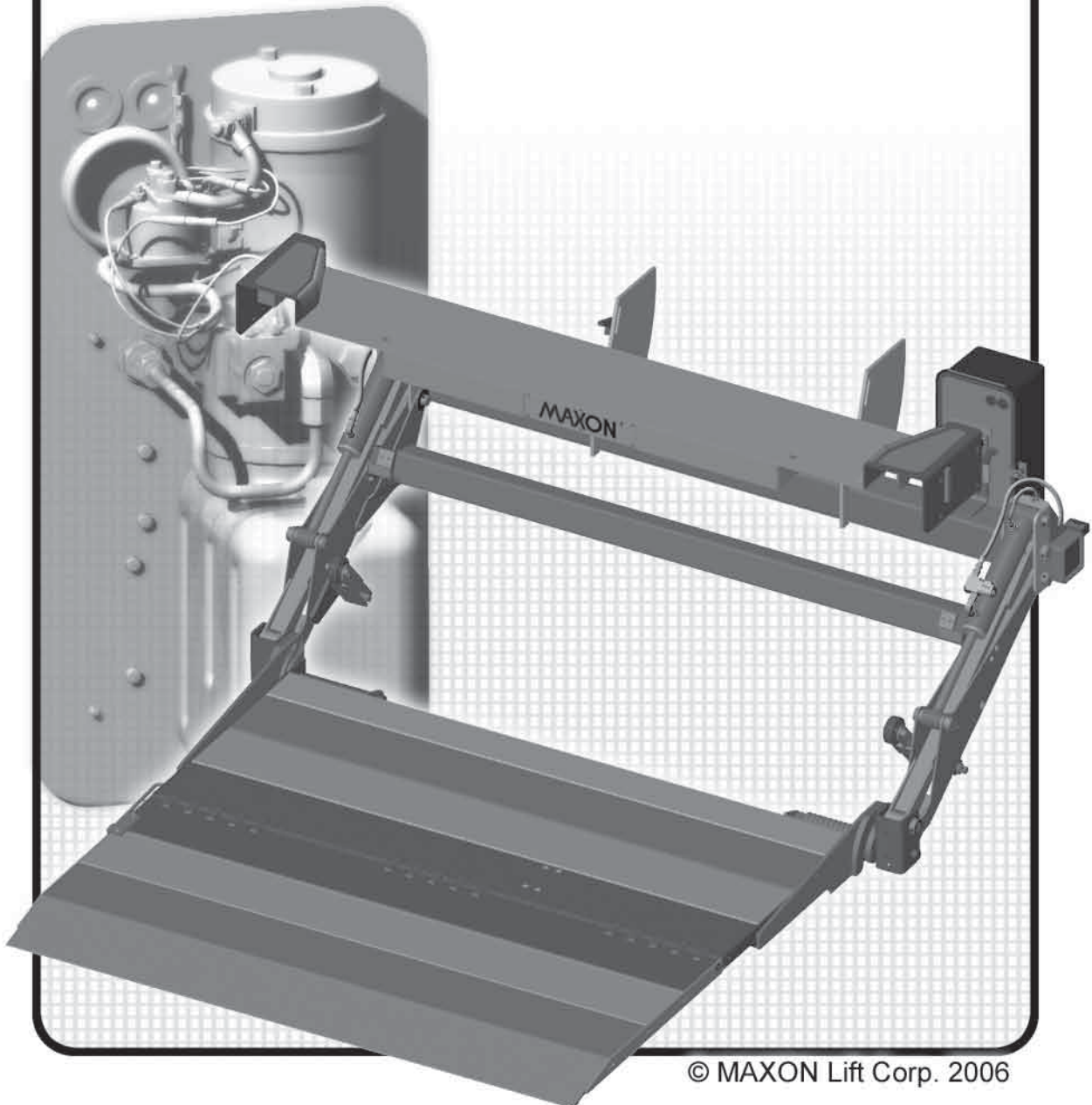

© MAXON Lift Corp. 2006

MAXON[®]

LIFT CORP.

11921 Slauson Ave.
Santa Fe Springs, CA. 90670

CUSTOMER SERVICE:

TELEPHONE (562) 464-0099 TOLL FREE (800) 227-4116

FAX: (888) 771-7713

NOTE: For latest version of all Manuals (and replacements), download the Manuals from Maxon's website at www.maxonlift.com.

WARRANTY/ RMA POLICY & PROCEDURE

LIFTGATE WARRANTY

Type of Warranty: Full Parts and Labor

Term of Warranty: Standard Liftgates - 2 years from ship date or 6,000 cycles
Premium Liftgates - 2 years from ship date or 10,000 cycles

This warranty shall not apply unless the product is installed, operated and maintained in accordance with MAXON Lift's specifications as set forth in MAXON Lift's Installation, Operation and Maintenance manuals. This warranty does not cover normal wear, maintenance or adjustments, damage or malfunction caused by improper handling, installation, abuse, misuse, negligence, or carelessness of operation. In addition, this warranty does not cover equipment that has had unauthorized modifications or alterations made to the product.

MAXON agrees to replace any components which are found to be defective during the first 2 years of service, and will reimburse for labor based on MAXON's Liftgate Warranty Flat Rate Schedule. (Copy of the Flat Rate is available at www.maxonlift.com.)

All warranty repairs must be performed by an authorized MAXON warranty facility. For any repairs that may exceed \$500, including parts and labor, MAXON's Technical Service Department must be notified and an "Authorization Number" obtained.

All claims for warranty must be received within 30 Days of the repair date, and include the following information:

1. Liftgate Model Number and Serial Number
2. The End User must be referenced on the claim
3. Detailed Description of Problem
4. Corrective Action Taken, and Date of Repair
5. Parts used for Repair, Including MAXON Part Number(s)
6. MAXON R.M.A. # and/or Authorization # if applicable (see below)
7. Person contacted at MAXON if applicable
8. Claim must show detailed information i.e. Labor rate and hours of work performed

Warranty claims can also be placed on-line at www.maxonlift.com. On-line claims will be given priority processing.

All claims for warranty will be denied if paperwork has not been received or claim submitted via Maxon website for processing by MAXON's Warranty Department within 30 days of repair date.

All components may be subject to return for inspection, prior to the claim being processed. MAXON products may not be returned without prior written approval from MAXON's Technical Service Department. Returns must be accompanied by a copy of the original invoice or reference with original invoice number and are subject to a credit deduction to cover handling charges and any necessary reconditioning costs. **Unauthorized returns will be refused and will become the responsibility of the returnee.**

Any goods being returned to MAXON Lift must be pre-approved for return, and have the R.M.A. number written on the outside of the package in plain view, and returned freight prepaid. All returns are subject to a 15% handling charge if not accompanied by a detailed packing list. Returned parts are subject to no credit and returned back to the customer.

Defective Parts requested for return must be returned within 30 days of the claim date for consideration to:

MAXON Lift Corp.
16205 Distribution Way, Cerritos, CA 90703
Attn: RMA# _____

MAXON's warranty policy does not include the reimbursement for travel time, towing, vehicle rental, service calls, oil, batteries or loss of income due to downtime. Fabrication or use of non Maxon parts, which are available from MAXON, are also not covered.

MAXON's Flat Rate Labor Schedule takes into consideration the time required for diagnosis of a problem.

All Liftgates returned are subject to inspection and a 15% restocking fee. Any returned Liftgates or components that have been installed or not returned in new condition will be subject to an additional reworking charge which will be based upon the labor and material cost required to return the Liftgate or component to new condition.

PURCHASE PART WARRANTY

Term of Warranty: 1 Year from Date of Purchase.

Type of Warranty: Part replacement only

will guarantee all returned genuine MAXON replacement parts upon receipt and inspection of parts and original invoice.

All warranty replacements parts will be sent out via ground freight. If a Rush Shipment is requested all freight charges will be billed to the requesting party.

MAXON

TABLE OF CONTENTS

WARNINGS	6
LIFTGATE TERMINOLOGY	7
PERIODIC MAINTENANCE	8
PERIODIC MAINTENANCE CHECKS.....	8
PERIODIC MAINTENANCE CHECKLIST	11
CHECKING HYDRAULIC FLUID.....	12
CHANGING HYDRAULIC FLUID	14
PLATFORM TORSION SPRING ADJUSTMENT	17
REPLACING PLATFORM TORSION SPRING	20
PARTS BREAKDOWN	22
MAIN ASSEMBLY: GPTLR-25 & GPTLR-33 (ALUMINUM PLATFORM)	22
MAIN ASSEMBLY: GPTLR-44 & GPTLR-55 (ALUMINUM PLATFORM)	24
MAIN ASSEMBLY: GPTLR-25 & GPTLR-33 (STEEL PLATFORM & RAMP OPTION).....	26
MAIN FRAME, LIFTING ARMS, & PARALLEL ARMS: GPTLR-25 & GPTLR-33.....	28
MAIN FRAME, LIFTING ARMS, & PARALLEL ARMS: GPTLR-44 & GPTLR-55.....	32
LH & RH PLATFORM SEATS: GPTLR-25 & GPTLR-33 (ALUMINUM PLATFORM WITH FIXED RAMP OR CART STOPS ONLY).....	36
LH & RH PLATFORM SEATS: GPTLR-25 & GPTLR-33 (ALUMINUM PLATFORM WITH RETENTION RAMP ONLY).....	37
LH & RH PLATFORM SEATS: GPTLR-25 & GPTLR-33 (STEEL PLATFORM ONLY)	38
LH & RH PLATFORM SEATS: GPTLR-44 & GPTLR-55 (ONLY ALUMINUM PLATFORM WITH FIXED RAMP OR CART STOPS).....	39
LH & RH PLATFORM SEATS: GPTLR-44 & GPTLR-55 (ONLY PLATFORM WITH RETENTION RAMP).....	40
PLATFORM & FLIPOVER ASSEMBLY (ALUMINUM)	42
PLATFORM & FLIPOVER ASSEMBLY WITH CART STOPS (ALUMINUM)	44
FLIPOVER WITH SINGLE CART STOP (ALUMINUM).....	46

FLIPOVER WITH DUAL CART STOPS (ALUMINUM)	48
PLATFORM & FLIPOVER ASSEMBLY WITH SINGLE RETENTION RAMP (ALUMINUM).....	50
FLIPOVER WITH SINGLE RETENTION RAMP (ALUMINUM)	52
PLATFORM & FLIPOVER ASSEMBLY (STEEL)	54
PUMP COVER & MOUNTING PLATE ASSEMBLY	55
GRAVITY DOWN HYDRAULIC COMPONENTS.....	56
POWER DOWN HYDRAULIC COMPONENTS.....	58
12 VDC POWER UNIT (GRAVITY DOWN)	60
12 VDC POWER UNIT (POWER DOWN)	62
DECALS	64
NONSKID & SAFETY STRIPING	66
CONTROL SWITCH AND POWER CABLE	67
HYDRAULIC SYSTEM DIAGRAMS	68
HYDRAULIC SCHEMATIC (GRAVITY DOWN).....	68
HYDRAULIC SCHEMATIC (POWER DOWN)	69
ELECTRICAL SYSTEM DIAGRAMS	70
ELECTRICAL SCHEMATIC (GRAVITY DOWN)	70
ELECTRICAL SCHEMATIC (POWER DOWN)	71
RECOMMENDED BOLT TORQUES	72
TROUBLESHOOTING	73
PLATFORM WILL NOT RAISE	73
PLATFORM RAISES BUT LEAKS DOWN	74
PLATFORM RAISES PARTIALLY AND STOPS.....	75
LIFTGATE WILL NOT LIFT RATED CAPACITY	76
PLATFORM RAISES SLOWLY.....	77
PLATFORM WILL NOT LOWER, LOWERS TOO SLOWLY, OR LOWERS TOO QUICKLY	78

Comply with the following **WARNINGS** while maintaining Liftgates. See Operation Manual M-04-05 for operating safety requirements.

WARNING

- Read and understand the instructions in this **Maintenance Manual** before performing maintenance on the Liftgate.
- Before operating the Liftgate, read and understand the operating instructions in **Operation Manual M-04-05**.
- Comply with all **WARNING** and instruction decals attached to the Liftgate.
- Keep decals clean and legible. If decals are defaced or missing, replace them. Free replacement decals are available from **Maxon Parts Department**.
- Consider the safety and location of bystanders and location of nearby objects when operating the Liftgate. Stand to one side of the platform while operating the Liftgate
- Do not allow untrained persons to operate the Liftgate.
- Do not stand under, or allow obstructions under the platform when lowering the Liftgate. **Be sure your feet are clear of the Liftgate.**
- **Keep fingers, hands, arms, legs, and feet clear of moving Liftgate parts (and platform edges) when operating the Liftgate.**
- **Correctly stow platform when not in use. Extended platforms could create a hazard for people and vehicles passing by.**
- **Disconnect Liftgate power cable from battery** before repairing or servicing Liftgate.
- Wear appropriate safety equipment such as protective eyeglasses, faceshield and clothing while performing maintenance on the Liftgate and handling the battery. Debris from drilling and contact with battery acid may injure unprotected eyes and skin.
- Be careful working by an automotive type battery. Make sure the work area is well ventilated and there are no flames or sparks near the battery. Never lay objects on the battery that can short the terminals together. If battery acid gets in your eyes, immediately seek first aid. If acid gets on your skin, immediately wash it off with soap and water.
- If an emergency situation arises (vehicle or Liftgate) while operating the Liftgate, release the control Toggle Switch and the Liftgate will stop.
- A correctly installed Liftgate operates smoothly and reasonably quiet. The only noticeable noise during operation comes from the pump unit while the platform is raised. Listen for scraping, grating and binding noises and correct the problem before continuing to operate Liftgate.
- If it is necessary to stand on the platform while maintaining the Liftgate, keep your feet and any objects clear of the inboard edge of the platform. Your feet or objects on the platform could be trapped between the platform and the Liftgate extension plate.
- Never perform unauthorized modifications on the Liftgate. Modifications may result in early failure of the Liftgate and may create hazards for Liftgate operators and maintainers.
- Use only **Maxon Authorized Parts** for replacement parts. Provide Liftgate model and serial number information with your parts order. Order replacement parts from:

MAXON LIFT CORP. Customer Service
11921 Slauson Ave., Santa Fe Springs, CA 90670
Phone: (800) 227-4116

- To order parts by e-mail, submit orders to partssales@maxonlift.com.

MAXON[®]

11921 Slauson Ave. Santa Fe Springs, CA. 90670 (800) 227-4116 FAX (888) 771-7713

LIFTGATE TERMINOLOGY

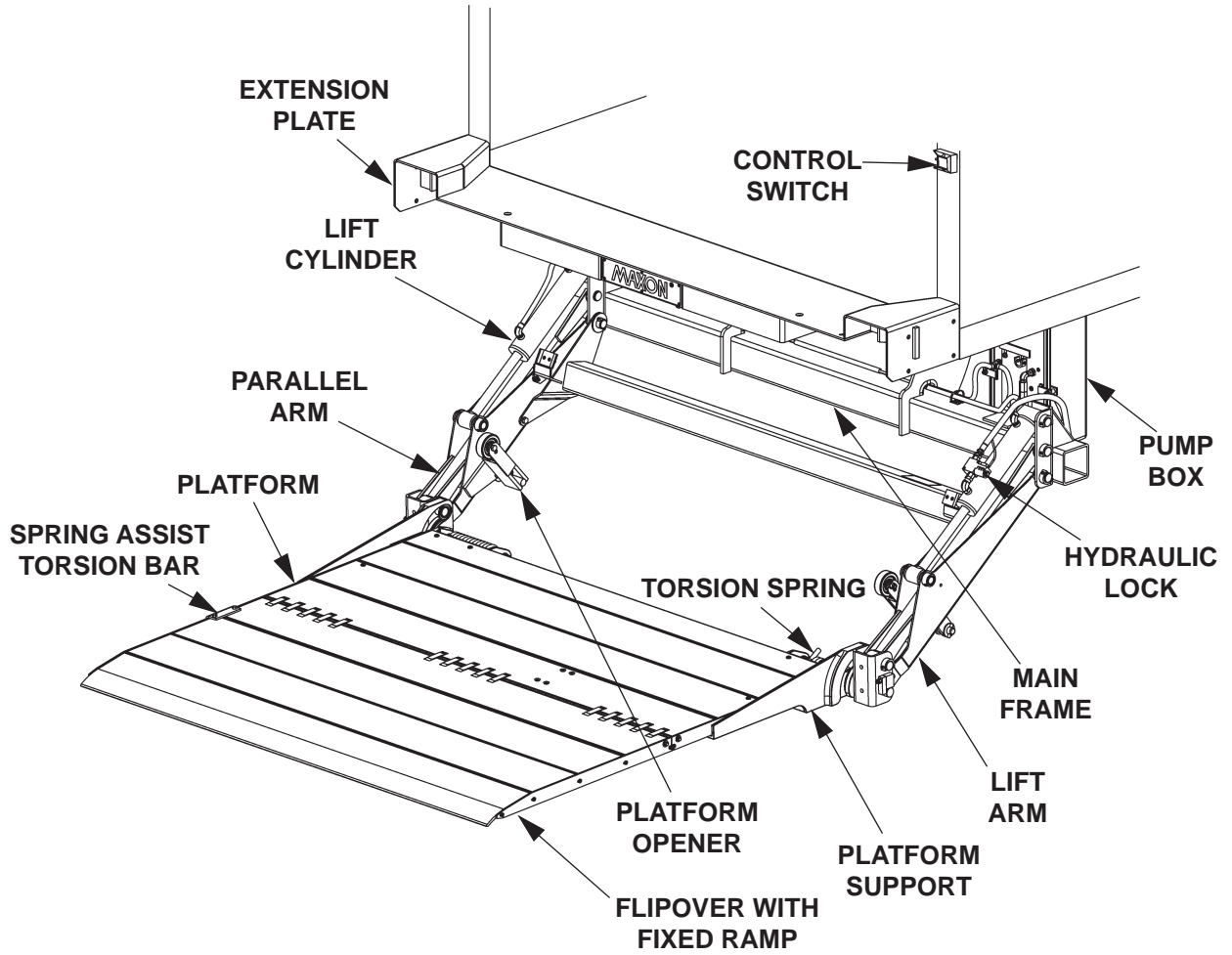

PERIODIC MAINTENANCE

PERIODIC MAINTENANCE CHECKS

WARNING

Never operate the Liftgate if parts are loose or missing.

NOTE: Make sure Vehicle is parked on level ground while performing the maintenance checks.

Quarterly or 1250 Cycles (whichever occurs first)

Check the Hydraulic Fluid level in the Pump Reservoir. Refer to the **CHECKING HYDRAULIC FLUID** procedure in the **PERIODIC MAINTENANCE** section.

If Hydraulic Fluid appears contaminated, refer to the **CHANGING HYDRAULIC FLUID** procedure in the **PERIODIC MAINTENANCE** section.

Keep track of the grade of Hydraulic Fluid in the Pump Reservoir and never mix two different grades of fluid.

Check all Hoses and Fittings for chafing and fluid leaks. Make sure Hydraulic Lock is in place and undamaged. Replace if necessary.

Check electrical wiring for chafing and make sure wiring connections are tight and free of corrosion.

Check that all **WARNING and instruction decals, nonskid stickers, and safety striping** are in place. Also make sure decals are readable and decals, nonskid, and safety striping are clean and undamaged.

Check that all roll pins are in place and protrude evenly from both sides of Hinge Pin collar. Replace roll pins if necessary.

Check for rust and oily surfaces on Liftgate. If there is rust or oil on Liftgate or if the Liftgate is dirty, clean it off. Touch up the paint where bare metal is showing.

Check both Platform torsion springs to make sure there is grease between the coils. If grease is not visible in the valley between each coil, apply spray-on white lithium grease.

Semi-annually or 2500 Cycles (whichever occurs first)

Visually check the Platform Hinge Pins for excessive wear and broken welds. See **PARTS BREAKDOWN** section for replacement parts. Also, do the **Quarterly or 1250 Cycles** maintenance checks.

Annually or 5000 Cycles (whichever occurs first)

Visually check the entire Liftgate for excessively worn parts and broken welds, especially Hinge Pins. See **PARTS BREAKDOWN** section for replacement parts.

Check the Platform and Flipover as follows. Unfold the Platform and Flipover. Raise the Platform to Vehicle Bed height and then lower it to the ground. Check if the Shackles and tip of Flipover touch the ground at the same time (**FIG. 9-1**). With the Shackles touching, tip of a ramp-style Flipover may be no more than 1/4" above the ground. A Flipover equipped with Retention Ramp may have a maximum 2" of ground clearance at the tip of the Flipover.

If the Shackles are 1" or more above the ground when the tip of the Flipover is touching the ground, perform the **ADJUST PLATFORM** procedure in the **Installation Manual (M-04-06)**. If the adjustment does not correct the problem, check pins and bearings at the pivot points on both sides of the Liftgate (**see FIG. 9-3**). See **PARTS BREAKDOWN** section for replacement parts.

Also, for Aluminum Flipovers equipped with Single Retention Ramp and for Steel Flipovers, ensure latch is in place, undamaged, and working correctly. See **PARTS BREAKDOWN** section for replacement parts.

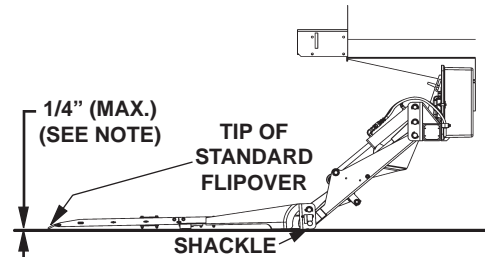

PLATFORM & SHACKLES TOUCHING THE GROUND
FIG. 9-1

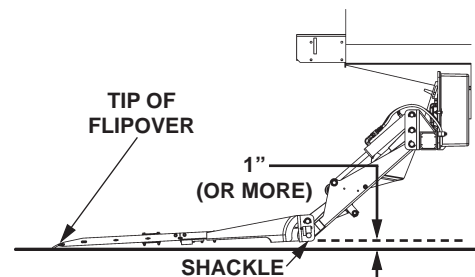

SHACKLES NOT TOUCHING THE GROUND
FIG. 9-2

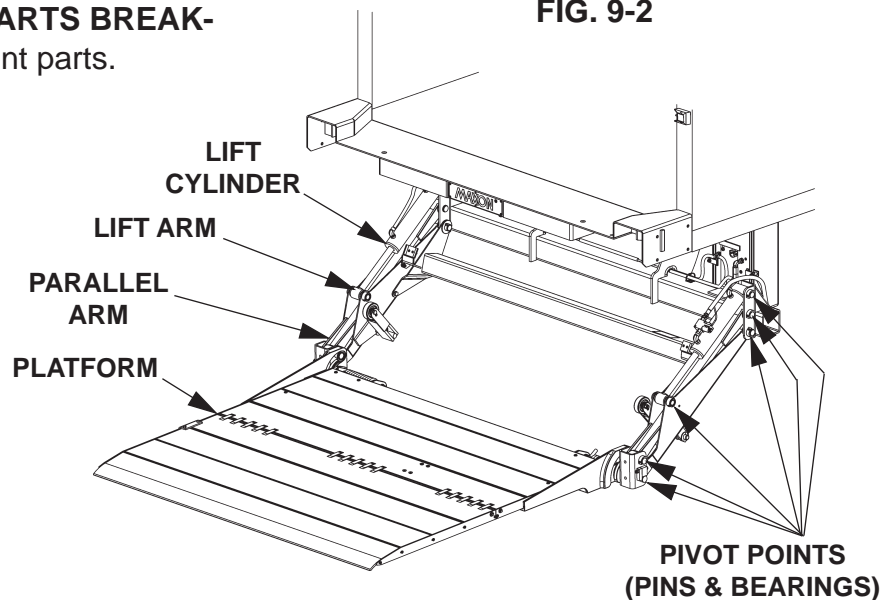

PIVOT POINTS TO CHECK
FIG. 9-3

PERIODIC MAINTENANCE

PERIODIC MAINTENANCE CHECKS - Continued

Annually or 5000 Cycles - Continued

To prevent unnecessary wear on Parallel Arms, check for worn Thrust Bearings as follows. Position the Platform 1"-2" above ground (FIG. 9-2A). Push against the Shackle (FIG. 9-2B, item 1) and measure clearance (FIG. 9-2B, item 1). Then push against other side of Shackle (FIG. 9-2B, item 2) and measure clearance (FIG. 9-2B, item 2). Repeat for LH side Shackle. If clearance is less than 0.050", replace Thrust Bearing. See **PARTS BREAKDOWN** section for replacement parts.

Also, do the **Semi-annual or 2500 Cycles** and **Quarterly or 1250 Cycles** checks.

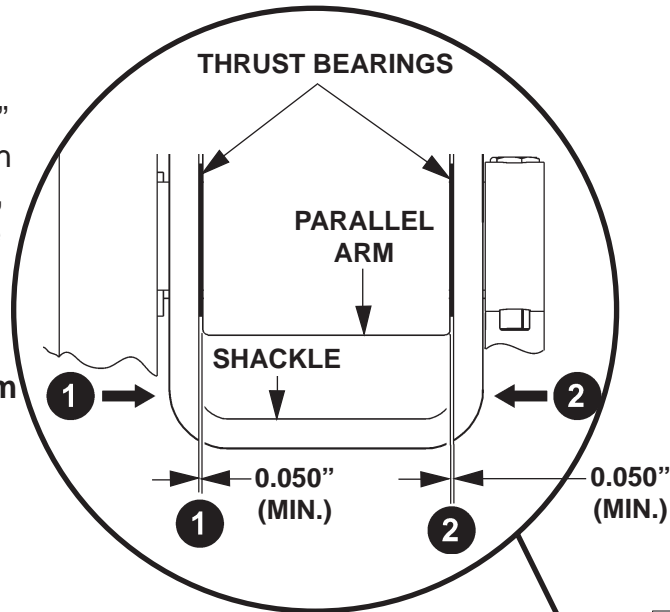

CHECKING SHACKLE CLEARANCES (RH SIDE SHOWN)
FIG. 10-2B

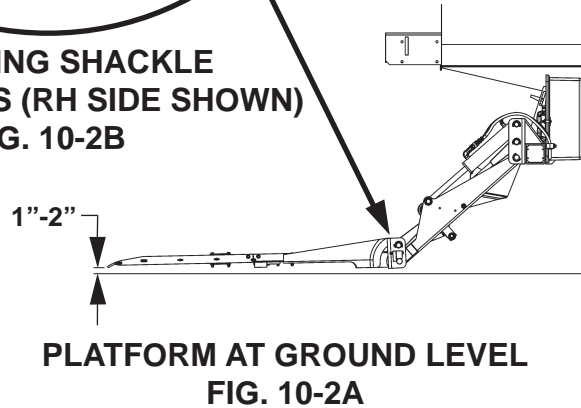

MAXON

11921 Slauson Ave. Santa Fe Springs, CA. 90670 (800) 227-4116 FAX (888) 771-7713

PERIODIC MAINTENANCE CHECKLIST

NOTE: Make sure Vehicle is parked on level ground while performing maintenance checks.

Quarterly or 1250 Cycles (whichever occurs first)

- Check the level and condition of the Hydraulic Fluid .
- Visually check all Hoses and Fittings for chafing and fluid leaks, and check Hydraulic Lock.
- Check electrical wiring for chafing and make sure wiring connections are tight and free of corrosion.
- Check that all **WARNING and instruction decals, nonskid stickers, and safety striping** are in place. Also make sure decals are readable and decals, nonskid, and safety striping are clean and undamaged.
- Check that all roll pins are in place and protrude evenly from both sides of Hinge Pin collar. Replace roll pins if necessary.
- Check for rust and oily surfaces on Liftgate. If there is rust or oil on Liftgate or if the Liftgate is dirty, clean it off. Touch up the paint where bare metal is showing.
- Check both Platform torsion springs to make sure there is grease in the valley between each coil. If grease is not visible, apply spray-on white lithium grease to the valley between each coil.

Semi-annually or 2500 Cycles (whichever occurs first)

- Visually check the Platform Hinge Pins for excessive wear and broken welds.
- Do the **Quarterly or 1250 Cycles Checks** on this Checklist.

Annually or 5000 Cycles (whichever occurs first)

- Visually check the entire Liftgate for excessively worn parts and broken welds, especially Hinge Pins.
- Visually check Platform & Flipover. (See the **PERIODIC MAINTENANCE CHECKS** topic for more information).
- Visually check the Thrust Bearings on the Shackles.
- Do the **Semi-annual or 2500 Cycles Checks** on this Checklist.
- Do the **Quarterly or 1250 Cycles Checks** on this Checklist.

For more details pertaining to this Checklist, see the **PERIODIC MAINTENANCE CHECKS** section in this Maintenance Manual).

PERIODIC MAINTENANCE CHECKING HYDRAULIC FLUID

CAUTION

Keep dirt, water and other contaminants from entering the hydraulic system. Before opening the hydraulic fluid reservoir filler cap, drain plug and hydraulic lines, clean up contaminants that can get in the openings. Also, protect the openings from accidental contamination.

NOTE: Use correct grade of hydraulic fluid for your location.

- | | |
|------------------------------|-------------------------------------|
| +70 to +140 Degrees F | - Grade ISO 32 |
| +40 to +105 Degrees F | - Grade ISO 15 |
| Below + 70 Degrees F | - Grade ISO 10 or MIL-H-5606 |

See **TABLES 13-1, 13-2 & 13-3**, on page 13, for recommended brands.

1. Unbolt and remove Pump Cover (**FIG. 12-1**).
2. Check the Hydraulic Fluid level in Reservoir as follows. With Liftgate stowed, or Platform at Vehicle bed height, level should be as shown in **FIG. 12-2**.

NOTE: If the Hydraulic Fluid in the Reservoir is contaminated, do the **CHANGING HYDRAULIC FLUID** procedure in this section.

3. If needed, add fluid to the Reservoir as follows. Pull out (no threads) Filler Cap (**FIG. 12-2**). Fill the Reservoir with Hydraulic Fluid to level shown in **FIG. 12-2**. Reinstall Filler Cap (**FIG. 12-2**).

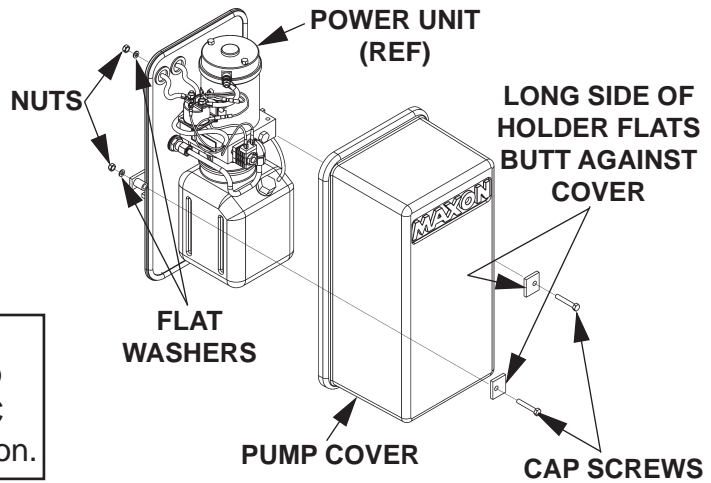

**UNBOLTING / BOLTING PUMP COVER
FIG. 12-1**

CAUTION

Pump Cover must be correctly secured to prevent it from becoming a hazard. To secure Pump Cover, the long side of the Holder Flats must butt against Pump Cover as shown in the illustration.

4. Bolt on the Pump Cover as shown in **FIG. 12-1**. Torque the 5/16"-18 cover bolts from **20 to 29 LBS.-FT.**

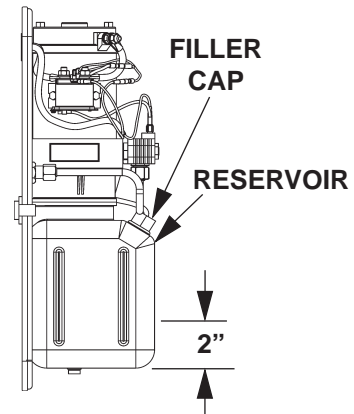

**POWER UNIT FLUID LEVEL
FIG. 12-2**

ISO 32 HYDRAULIC OIL	
RECOMMENDED BRANDS	PART NUMBER
AMSOIL	AWH-05
CHEVRON	HIPERSYN 32
KENDALL	GOLDEN MV
SHELL	TELLUS T-32
EXXON	UNIVIS N-32
MOBIL	DTE-13M, DTE-24, HY- DRAULIC OIL-13

TABLE 13-1

ISO 15 HYDRAULIC OIL	
RECOMMENDED BRANDS	PART NUMBER
AMSOIL	AWF-05
CHEVRON	FLUID A, AW-MV-15
KENDALL	GLACIAL BLU
SHELL	TELLUS T-15
EXXON	UNIVIS HVI-13
MOBIL	DTE-11M
ROSEMEAD	THS FLUID 17111

TABLE 13-2

ISO-10 OR MIL-H-5606 HYDRAULIC FLUID	
RECOMMENDED BRANDS	PART NUMBER
AMSOIL	N/A
CHEVRON	FLUID A, FLUID G
KENDALL	GLACIAL BLU
SHELL	AEROSHELL FLUID-41
EXXON	UNIVIS HVI-13
MOBIL	AERO HFA
ROSEMEAD	THS FLUID 17111

TABLE 13-3

PERIODIC MAINTENANCE CHANGING HYDRAULIC FLUID

CAUTION

Keep dirt, water and other contaminants from entering the hydraulic system. Before opening the hydraulic fluid reservoir filler cap, drain plug and hydraulic lines, clean up contaminants that can get in the openings. Also, protect the openings from accidental contamination.

NOTE: Use correct grade of hydraulic fluid for your location.

+70 to +140 Degrees F - Grade ISO 32
+40 to +105 Degrees F - Grade ISO 15
Below + 70 Degrees F - Grade ISO 10 or MIL-H-5606

See TABLES 13-1, 13-2 & 13-3 on previous page for recommended brands.

GRAVITY DOWN & POWER DOWN LIFTGATES

1. Unbolt and remove Pump Cover (FIG. 14-1). Place empty 5 Gallon Bucket under Drain Plug (FIG. 14-2).

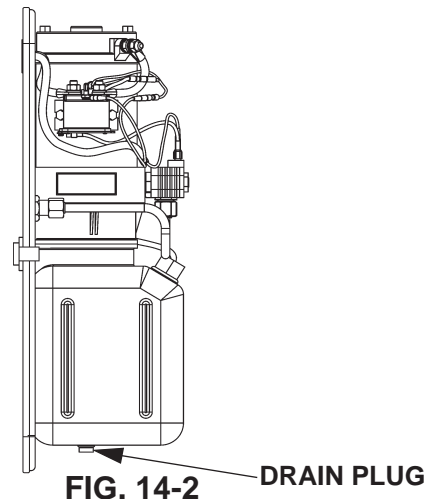
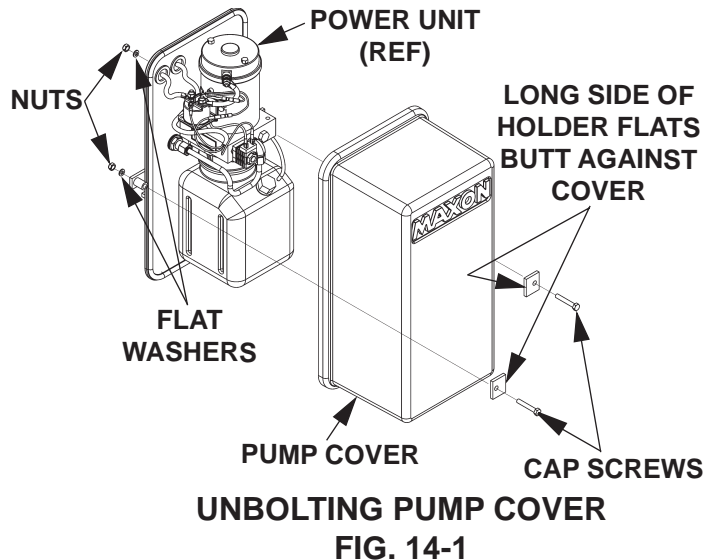

MAXON

11921 Slauson Ave. Santa Fe Springs, CA. 90670 (800) 227-4116 FAX (888) 771-7713

GRAVITY DOWN LIFTGATES

1. Lower Platform to ground. Pull out (no threads) Drain Plug (**FIG. 15-1**). Drain hydraulic fluid from system. Reinstall Drain Plug.
2. Pull out (no threads) Filler Cap (**FIG. 15-1**) and refill reservoir with Hydraulic Fluid to level shown in **FIG. 15-1**. Reinstall Filler Cap (**FIG. 15-1**).
3. Stow the Lift and do the **CHECKING HYDRAULIC FLUID** procedure in this section of the manual.

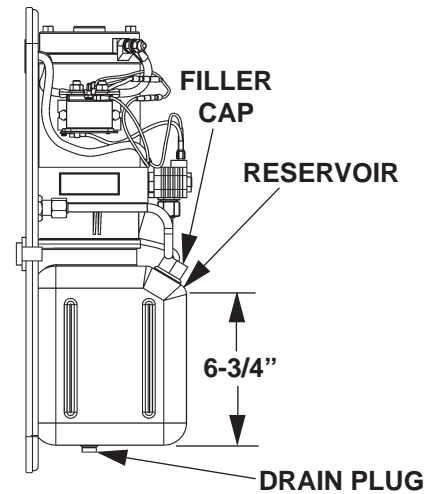

GRAVITY DOWN PUMP & MOTOR
FIG. 15-1

POWER DOWN LIFTGATES

1. Open and raise Platform to vehicle bed height. Pull out (no threads) Drain Plug (**FIG. 15-1**). Drain hydraulic fluid.

NOTE: MAXON recommends using dielectric grease on all electrical connections.

2. Disconnect the Motor Power Cable (**FIG. 15-2**) from bottom Starter Solenoid. Lower the Platform while draining the remaining hydraulic fluid from system. Reinstall Drain Plug. Reconnect the Motor Power Cable to bottom Starter Solenoid. Torque hex nut to **95 LBS.-IN.**
3. Pull out (no threads) Filler Cap (**FIG. 15-1**) and refill reservoir with Hydraulic Fluid to level shown in **FIG. 15-1**. Reinstall Filler Cap (**FIG. 15-1**).
4. Stow the Lift and do the **CHECKING HYDRAULIC FLUID** procedure in this section of the manual.

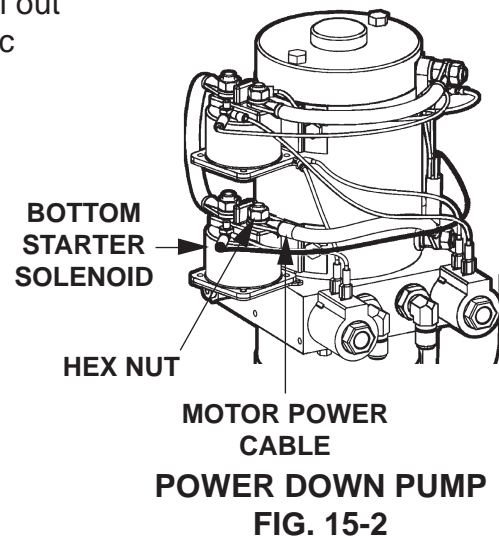

POWER DOWN PUMP
FIG. 15-2

CHANGING HYDRAULIC FLUID - Continued

GRAVITY DOWN & POWER DOWN LIFTGATES

CAUTION

Pump Cover must be correctly secured to prevent it from becoming a hazard. To secure Pump Cover, the long side of the Holder Flats must butt against Pump Cover as shown in the illustration.

Bolt on the Pump Cover as shown in FIG. 16-1. Torque the 5/16"-18 cover bolts from **20 to 29 LBS.-FT.**

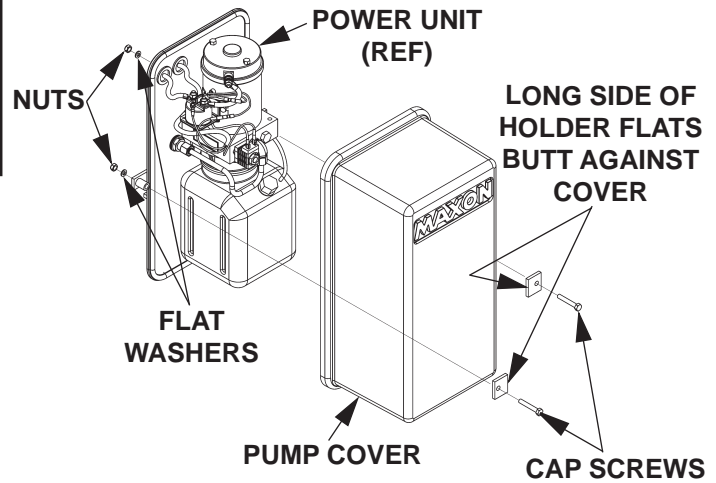

BOLTING PUMP COVER

FIG. 16-1

MAXON

11921 Slauson Ave. Santa Fe Springs, CA. 90670 (800) 227-4116 FAX (888) 771-7713

PERIODIC MAINTENANCE

PLATFORM TORSION SPRING ADJUSTMENT

NOTE: Perform the following adjustment if Platform feels heavy as you start to fold it for stowing. If adjusted as follows, the torsion springs will reduce the amount of effort you need to start folding the Platform.

1. Make sure vehicle is parked on level ground. **LOWER** the Liftgate about 1" above the ground (**FIG. 17-1**).

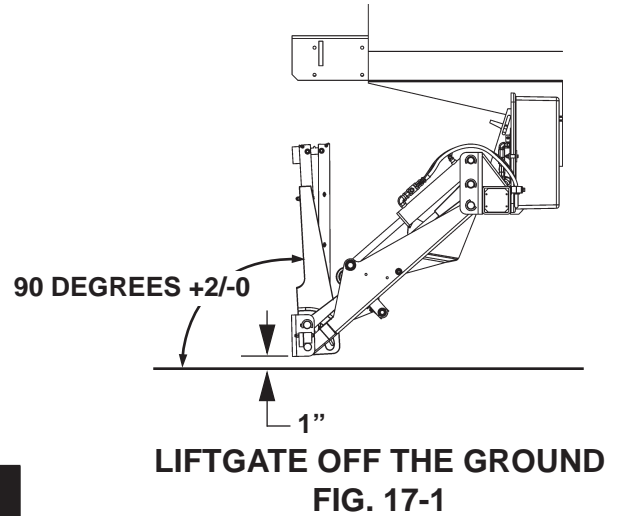

! WARNING

To prevent possible injury and damage to Liftgate, have another qualified person hold Platform in position to keep it from falling open.

2. Position Platform and Flipover to 90 degrees, +2 / -0 degrees (**FIG. 17-1**). Get a second person to hold the Platform in place while you take measurements.
3. On RH side of Platform, position the Torsion Spring so it rests on Pin (**FIGS. 17-1 & 17-2B**). Make sure long leg of Torsion Spring is parallel to chamfered surface on Support Block (**FIG. 17-2B**). Measure gap "H" between leg of the Torsion Spring and Support Block (**FIG. 17-2B**). Repeat for Torsion Spring on LH side of Platform.

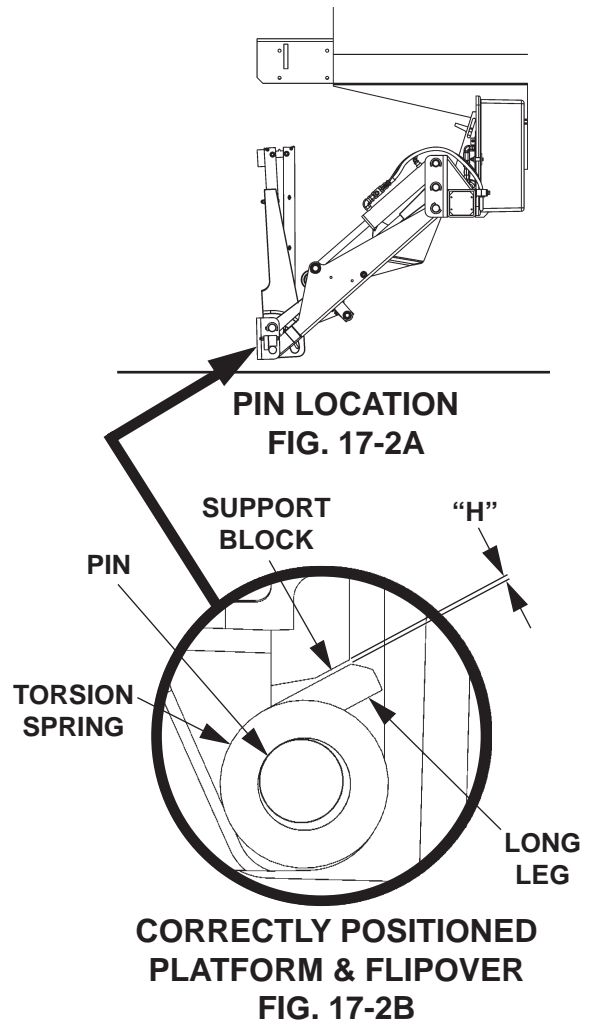

PLATFORM TORSION SPRING ADJUSTMENT - Continued

NOTE: If there is little or no gap, a shim is not required. Skip to step 7.

- Fabricate 2 shims from A-36 steel as shown in **FIG 18-1**. The thickness must be equal to the “H” measurement taken in the previous step and an added 1/16”. **For example, if you measured 1/8” for “H”, add another 1/16” to make the shim 3/16” thick.**

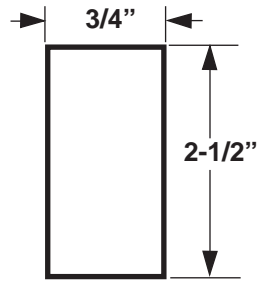

SHIM (THICKNESS “H”) MADE FROM STEEL FLAT
FIG. 18-1

CAUTION
Heat from welding near the Platform Torsion Springs can weaken the Springs. Cover the Torsion Springs with a wet cloth before welding.

- Weld 1 shim (**FIG. 18-2**) to Support Block on RH side of Platform as shown in **FIG. 18-2**. Repeat for Support Block on LH side of Platform.

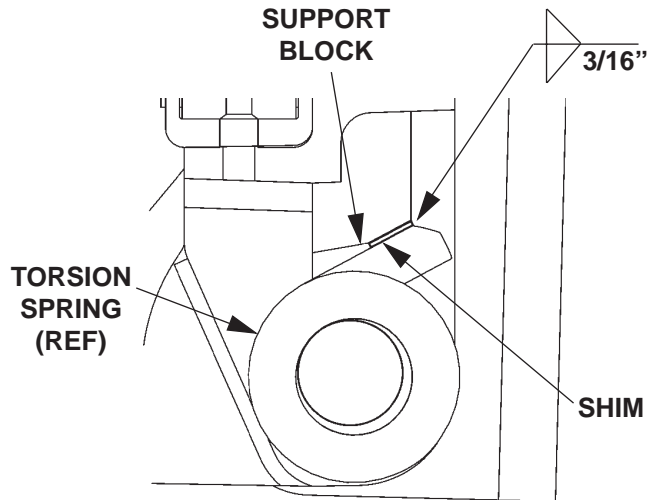

WELDING SHIM ON SUPPORT BLOCK
FIG. 18-2

6. **LOWER** Platform to the ground. Make sure Platform folds (**FIG. 19-1**) and unfolds (**FIG. 19-2**) easily.

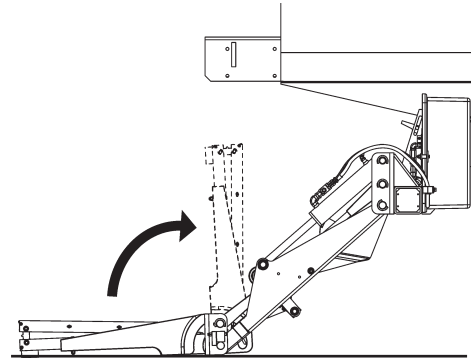

FOLDING PLATFORM
FIG. 19-1

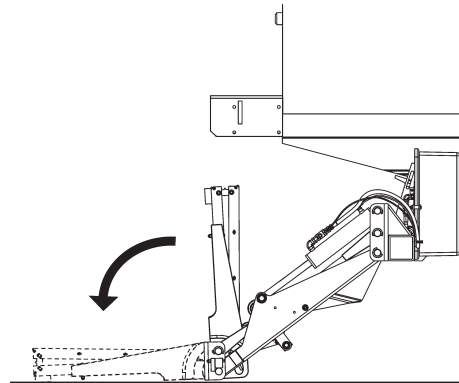

UNFOLDING PLATFORM
FIG. 19-2

CAUTION
Stow Liftgate under hydraulic pressure.

7. Fold the Platform (**FIG. 19-1**) and stow Liftgate (**FIG. 19-3**).

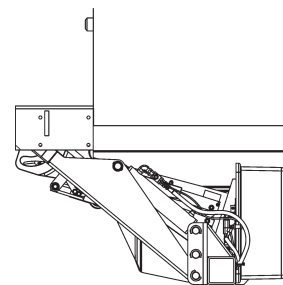

LIFTGATE STOWED
FIG. 19-3

PERIODIC MAINTENANCE

REPLACING PLATFORM TORSION SPRING

NOTE: The following procedure shows how to replace Torsion Spring on RH side of Platform. Use this procedure for replacing Torsion Spring on the LH Side.

1. Fold Flipover onto Platform.
2. Fold Platform.
3. Raise Liftgate to a convenient work height to gain access and release tension on the Torsion Spring.

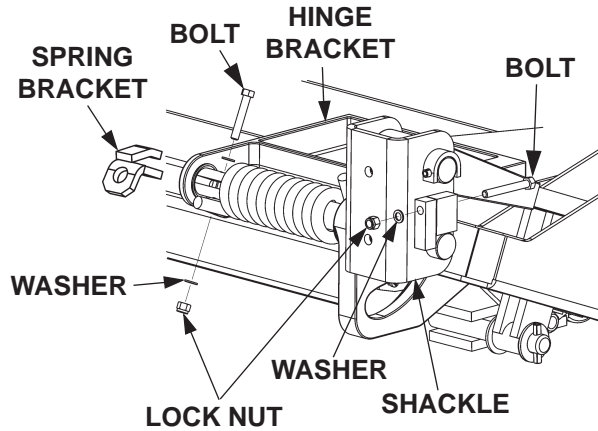

FIG. 20-1

CAUTION

To prevent injury and equipment damage, make sure there is no tension on torsion spring before removing hinge pin.

4. Unbolt Hinge Pin from Shackle and Spring Bracket (FIG. 20-1). Remove bolts, washers, and lock nuts. Drive the Hinge Pin outboard toward the Shackle just enough to free the torsion spring (FIG. 20-2). Remove the Torsion Spring.

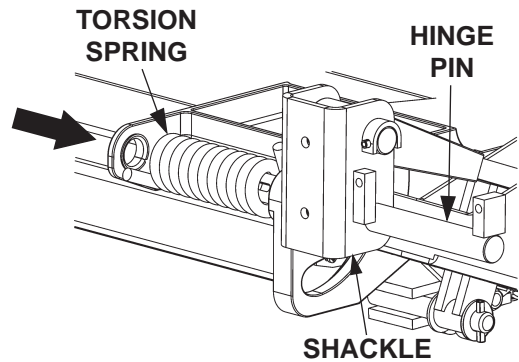

FIG. 20-2

5. Install the Torsion Spring as shown in **FIG. 21-1**. Make sure the long leg of the spring is inserted in the Spring Bracket (**FIG. 21-1**). Make sure the short end of the spring is visible and resting against the Hinge Bracket (**FIG. 21-1**).

6. Drive the Hinge Pin into correct position through the Hinge Bracket as shown in **FIG. 21-1**. Line up the bolt hole in the Hinge Pin with the hole in the Shackle and Spring Bracket. Bolt the Hinge Pin to Hinge Bracket and Spring Bracket with bolts, washers, lock nuts (**FIG. 21-1**). Torque the 3/8"-16 Spring Pin bolt and 3/8"-16 Spring Bracket bolt **35 to 52 LBS.-FT.**

7. Operate the Liftgate according to instructions in **Operation Manual** to make sure it operates correctly.

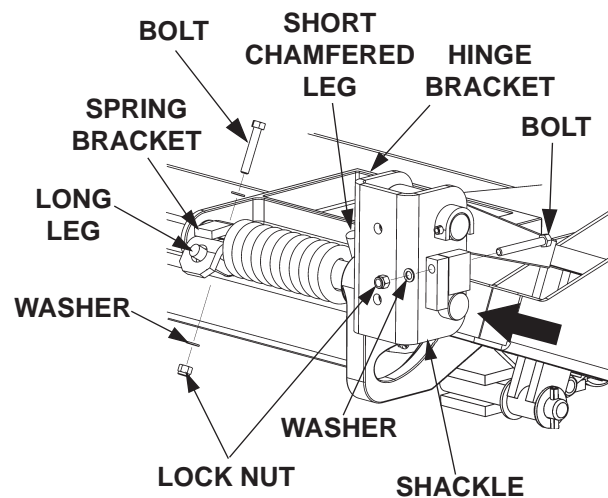

FIG. 21-1

PARTS BREAKDOWN

MAIN ASSEMBLY: GPTLR-25 & GPTLR-33 (ALUMINUM PLATFORM)

MAXON®

11921 Slauson Ave. Santa Fe Springs, CA. 90670 (800) 227-4116 FAX (888) 771-7713

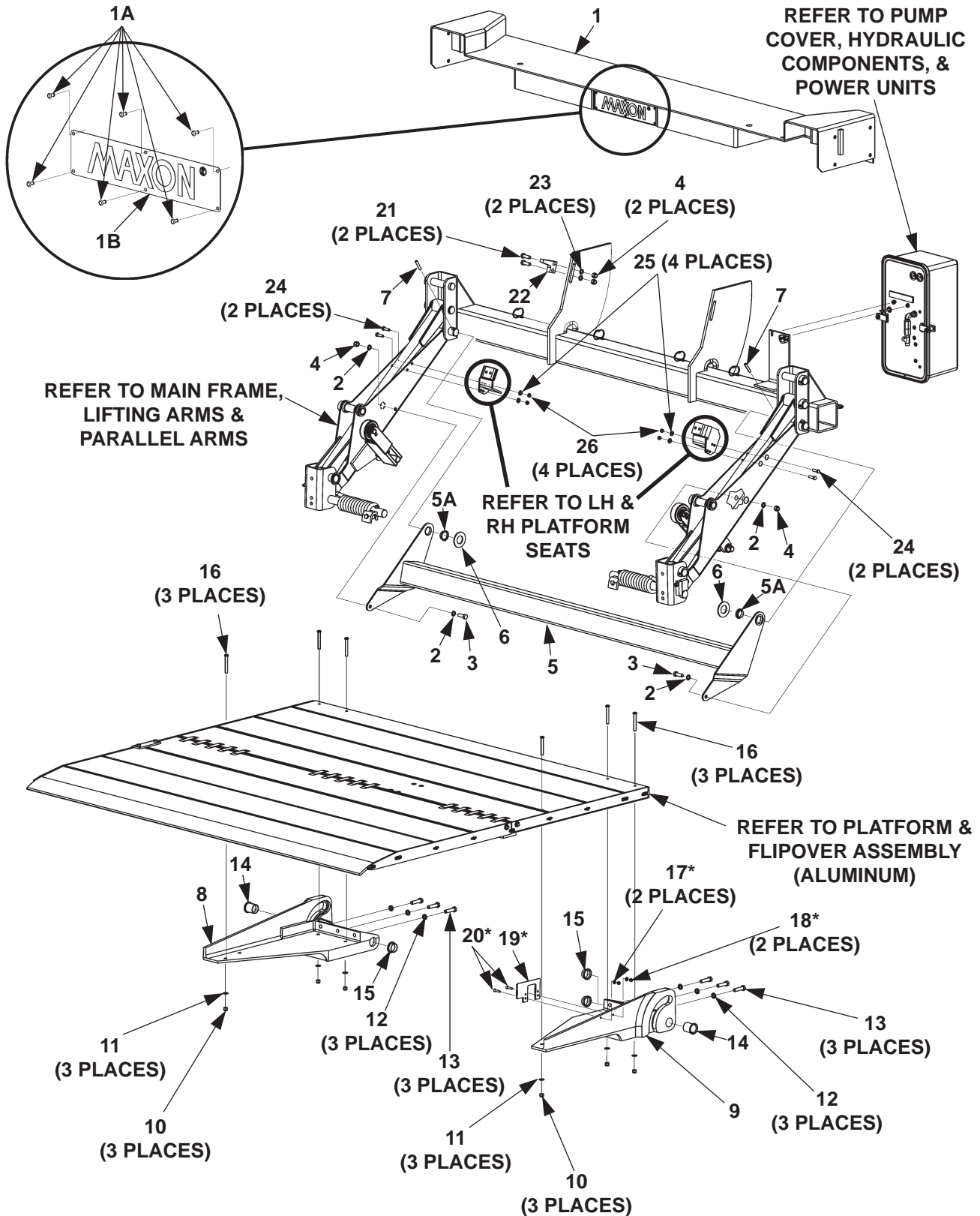

ITEM	QTY.	PART NO.	DESCRIPTION
1	1	281090-01	EXTENSION PLATE ASSEMBLY (96" WIDE)
		281090-02	EXTENSION PLATE ASSEMBLY (102" WIDE)
1A	6	207644	RIVET, 3/16" X .40" GRIP
1B	1	050175	MAXON PLATE
2	4	902000-14	FLAT WASHER, 1/2"
3	2	900035-3	CAP SCREW, 1/2"-13 X 1-1/2" LG.
4	4	901010	LOCK NUT, 1/2"-13
5	1	281580-01	ICC BUMPER (96" WIDE)
		281580-02	ICC BUMPER (102" WIDE)
5A	2	908088-01	BEARING, FLANGED
6	2	902013-21	FLAT WASHER, 1-3/8"
7	2	221416	ROLL PIN, 3/8" X 2" LG.
8	1	280981-01	SUPPORT, LH
9	1	280981-02	SUPPORT, RH
10	6	901002	LOCK NUT, 3/8"-16
11	6	902013-11	FLAT WASHER, 3/8"
12	6	902011-6	LOCK WASHER, 1/2"
13	6	900035-5	CAP SCREW, 1/2"-13 X 2" LG.
14	2	908026-01	BEARING, 1-3/4" LG.
15	2	908008-02	BEARING, 5/8" LG.
16	6	900064-07	BUTTONHEAD SCREW, 3/8"-16 X 3" LG.
17*	2	902013-09	FLAT WASHER, 1/4"
18*	2	901000	LOCK NUT, 1/4"-20
19*	1	281154-01	LATCH BRACKET
20*	2	900044-7	SOCKET SCREW, 1/4"-20 X 1-1/4" LG.
21	2	900035-7	CAP SCREW, 1/2"-13 X 2-1/2" LG.
22	1	281673-01	STOP BLOCK
23	2	902000-16	FLAT WASHER, 5/8"
24	4	900014-5	CAP SCREW, 3/8"-16 X 1-1/4" LG, GRADE 8
25	4	902000-10	FLAT WASHER, 3/8"
26	4	901016-4	LOCK NUT, 3/8"-16

*PART OF GPTLR WITH SINGLE RETENTION RAMP FLIPOVER, ONLY

MAIN ASSEMBLY: GPTLR-44 & GPTLR-55 (ALUMINUM PLATFORM)

MAXON®

11921 Slauson Ave. Santa Fe Springs, CA. 90670 (800) 227-4116 FAX (888) 771-7713

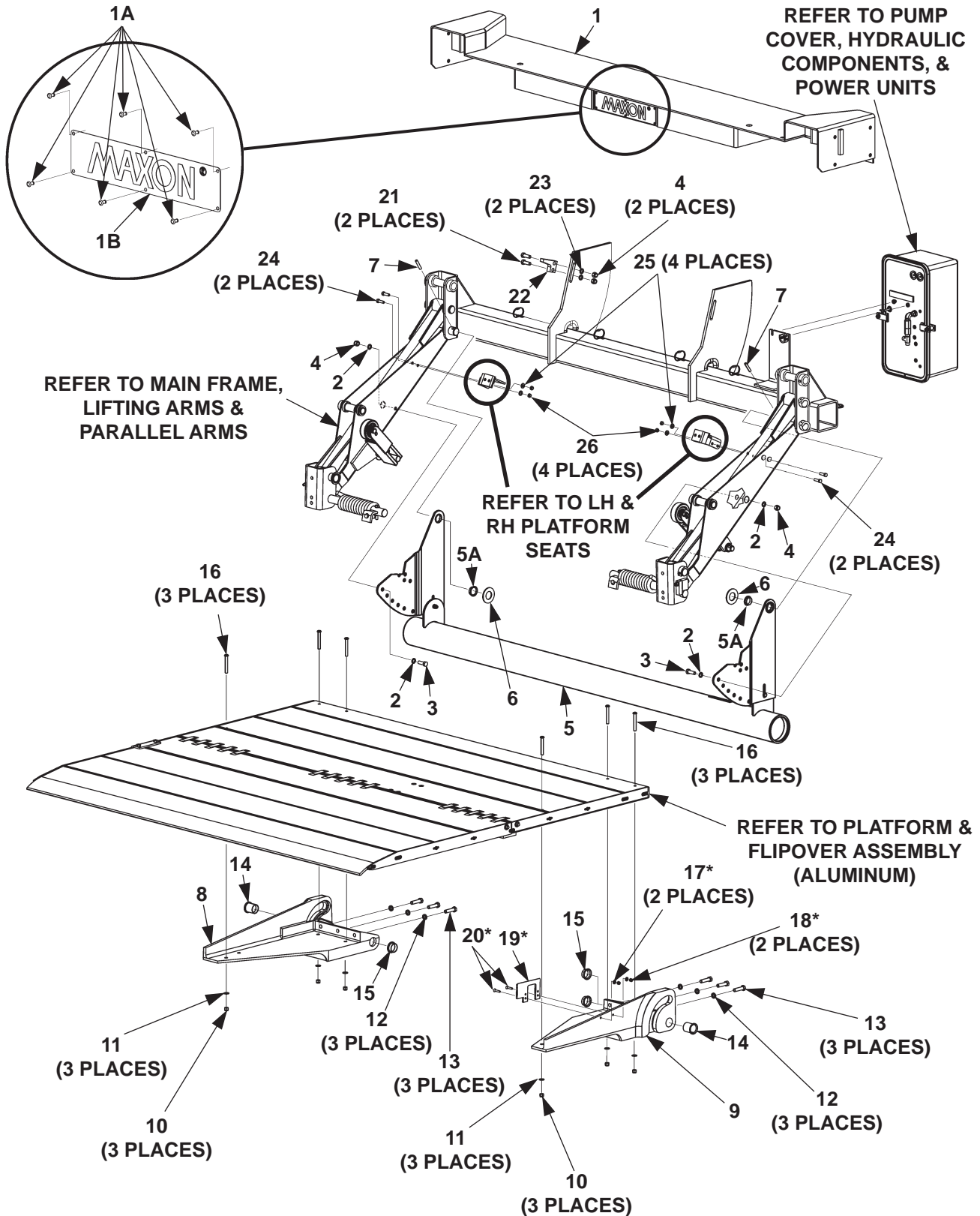

ITEM	QTY.	PART NO.	DESCRIPTION
1	1	281120-01	EXTENSION PLATE ASSEMBLY (96" WIDE)
		281120-02	EXTENSION PLATE ASSEMBLY (102" WIDE)
1A	6	207644	RIVET, 3/16" X .40" GRIP
1B	1	050175	MAXON PLATE
2	4	902000-14	FLAT WASHER, 1/2"
3	2	900035-3	CAP SCREW, 1/2"-13 X 1-1/2" LG.
4	4	901010	LOCK NUT, 1/2"-13
5	1	281399-01	UNDERRIDE (96" WIDE)
		281399-02	UNDERRIDE (102" WIDE)
5A	2	908088-01	BEARING, FLANGED
6	2	902013-21	FLAT WASHER, 1-3/8"
7	2	221416	ROLL PIN, 3/8" X 2" LG.
8	1	281340-01	SUPPORT, LH
9	1	281340-02	SUPPORT, RH
10	6	901002	LOCK NUT, 3/8"-16
11	6	902013-11	FLAT WASHER, 3/8"
12	6	902011-6	LOCK WASHER, 1/2"
13	6	900035-5	CAP SCREW, 1/2"-13 X 2" LG.
14	2	908026-01	BEARING, 1-3/4" LG.
15	2	908008-02	BEARING, 5/8" LG.
16	6	900064-07	BUTTONHEAD SCREW, 3/8"-16 X 3" LG.
17*	2	902013-09	FLAT WASHER, 1/4"
18*	2	901000	LOCK NUT, 1/4"-20
19*	1	281154-01	LATCH BRACKET
20*	2	900044-7	SOCKET SCREW, 1/4"-20 X 1-1/4" LG.
21	2	900035-7	CAP SCREW, 1/2"-13 X 2-1/2" LG.
22	1	281673-01	STOP BLOCK
23	2	902000-16	FLAT WASHER, 5/8"
24	4	900014-6	CAP SCREW, 3/8"-16 X 1-1/2" LG, GRADE 8
25	4	902000-10	FLAT WASHER, 3/8"
26	4	901016-4	LOCK NUT, 3/8"-16

*PART OF GPTLR WITH SINGLE RETENTION RAMP FLIPOVER, ONLY

MAIN ASSEMBLY: GPTLR-25 & GPTLR-33 (STEEL PLATFORM & RAMP OPTION)

MAXON

11921 Slauson Ave. Santa Fe Springs, CA. 90670 (800) 227-4116 FAX (888) 771-7713

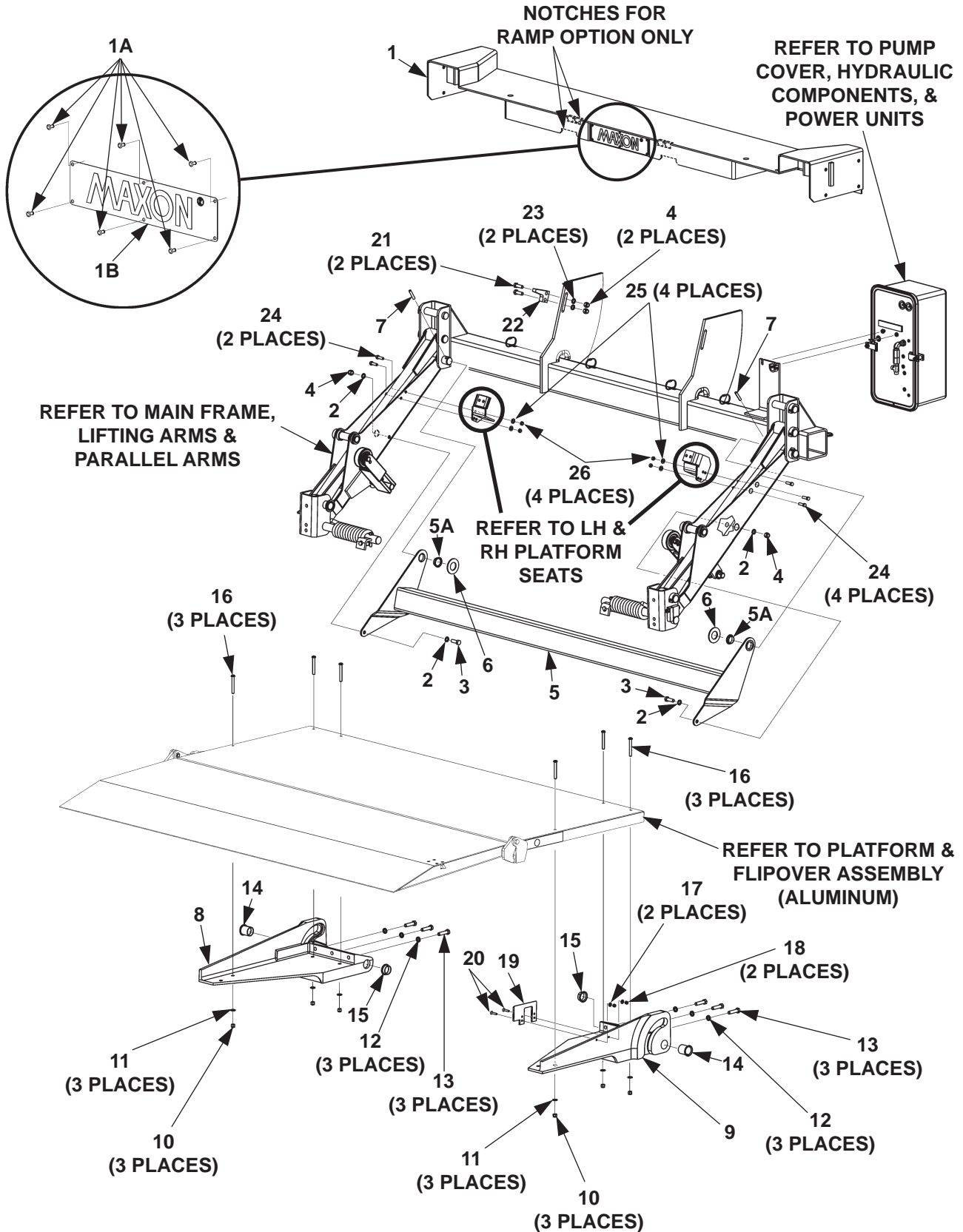

ITEM	QTY.	PART NO.	DESCRIPTION
1	1	281090-01	EXTENSION PLATE ASSEMBLY (96" WIDE)
		281090-02	EXTENSION PLATE ASSEMBLY (102" WIDE)
		281484-01	EXTENSION PLATE ASSEMBLY (96" WIDE RAMP OPTION)
		281484-02	EXTENSION PLATE ASSEMBLY (102" WIDE RAMP OPTION)
1A	6	207644	RIVET, 3/16" X .40" GRIP
1B	1	050175	MAXON PLATE
2	4	902000-14	FLAT WASHER, 1/2"
3	2	900035-3	CAP SCREW, 1/2"-13 X 1-1/2" LG.
4	2	901010	LOCK NUT, 1/2"-13
5	1	281580-01	ICC BUMPER (96" WIDE)
		281580-02	ICC BUMPER (102" WIDE)
5A	2	908088-01	BEARING, FLANGED
6	2	902013-21	FLAT WASHER, 1-3/8"
7	2	221416	ROLL PIN, 3/8" X 2" LG.
8	1	280981-01	SUPPORT, LH
9	1	280981-02	SUPPORT, RH
10	6	901002	LOCK NUT, 3/8"-16
11	6	902013-11	FLAT WASHER, 3/8"
12	6	902011-6	LOCK WASHER, 1/2"
13	6	900035-11	CAP SCREW, 1/2"-13 X 4" LG.
14	2	908026-01	BEARING, 1-3/4" LG.
15	2	908008-02	BEARING, 5/8" LG.
16	6	900064-07	BUTTONHEAD SCREW, 3/8"-16 X 3" LG.
17	2	902013-09	FLAT WASHER, 1/4"
18	2	901000	LOCK NUT, 1/4"-20
19	1	281415-01	LATCH BRACKET
20	2	900044-7	SOCKET SCREW, 1/4"-20 X 1-1/4" LG.
21	2	900035-7	CAP SCREW, 1/2"-13 X 2-1/2" LG.
22	1	281673-01	STOP BLOCK
23	2	902000-16	FLAT WASHER, 5/8"
24	4	900014-5	CAP SCREW, 3/8"-16 X 1-1/4" LG, GRADE 8
25	4	902000-10	FLAT WASHER, 3/8"
26	4	901016-4	LOCK NUT, 3/8"-16

MAIN FRAME, LIFTING ARMS, & PARALLEL ARMS: GPTLR-25 & GPTLR-33

MAXON®

11921 Slauson Ave. Santa Fe Springs, CA. 90670 (800) 227-4116 FAX (888) 771-7713

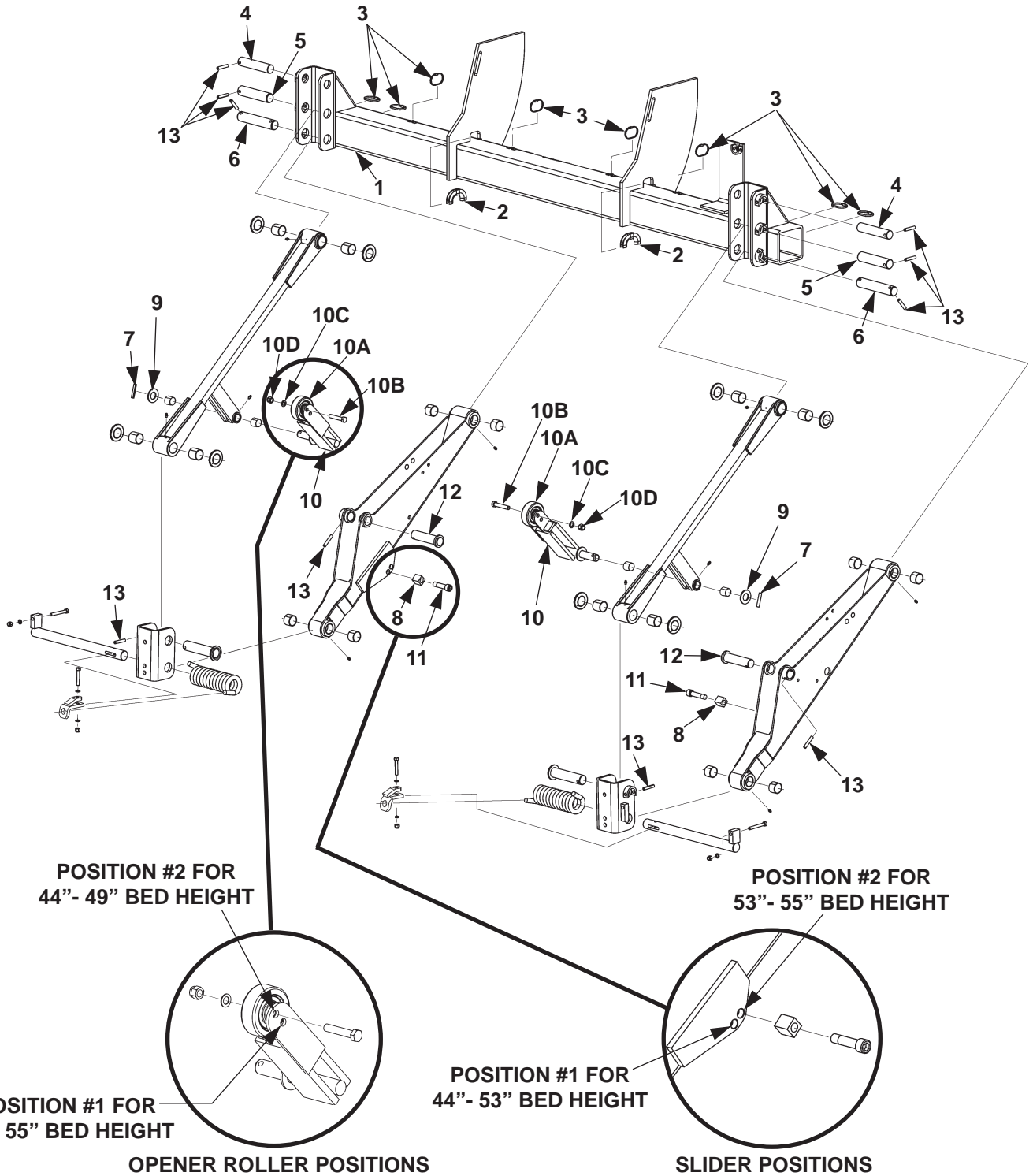

ITEM	QTY.	PART NO.	DESCRIPTION
1	1	280910-01	MAIN FRAME (96" WIDE GPTLR-25/33)
		280910-02	MAIN FRAME (102" WIDE GPTLR-25/33)
2	2	040103-5	SPLIT LOOM, 1/2" X 5" LG.
3	8	905322-01	PLASTIC TIE, 8" LG.
4	2	280969-02	PIN, 1-1/4" DIA X 5-13/16" LG.
5	2	280968-01	PIN, 1-3/8" DIA X 5-7/8" LG.
6	2	281005-01	PIN, 7" LG.
7	2	221416	ROLL PIN, 3/8" X 2" LG.
8	2	281643-01	SLIDER
9	2	902013-18	FLAT WASHER, 1-1/16"
10	2	281669-01	OPENER
10A	2	280082-01	ROLLER
10B	2	900035-8	CAP SCREW, 1/2"-13 X 2-3/4" LG.
10C	2	902000-14	FLAT WASHER, 1/2"
10C	2	901010	LOCK NUT, 1/2"-13
11	2	281644-01	PIN, SOCKET HEAD
12	2	281127-01	PIN, CYLINDER
13	10	904717-08	ROLL PIN, 3/8" X 2-1/2" LG.

MAIN FRAME, LIFTING ARMS, & PARALLEL ARMS: GPTLR-25 & GPTLR-33 - Continued

MAXON[®]

11921 Slauson Ave. Santa Fe Springs, CA. 90670 (800) 227-4116 FAX (888) 771-7713

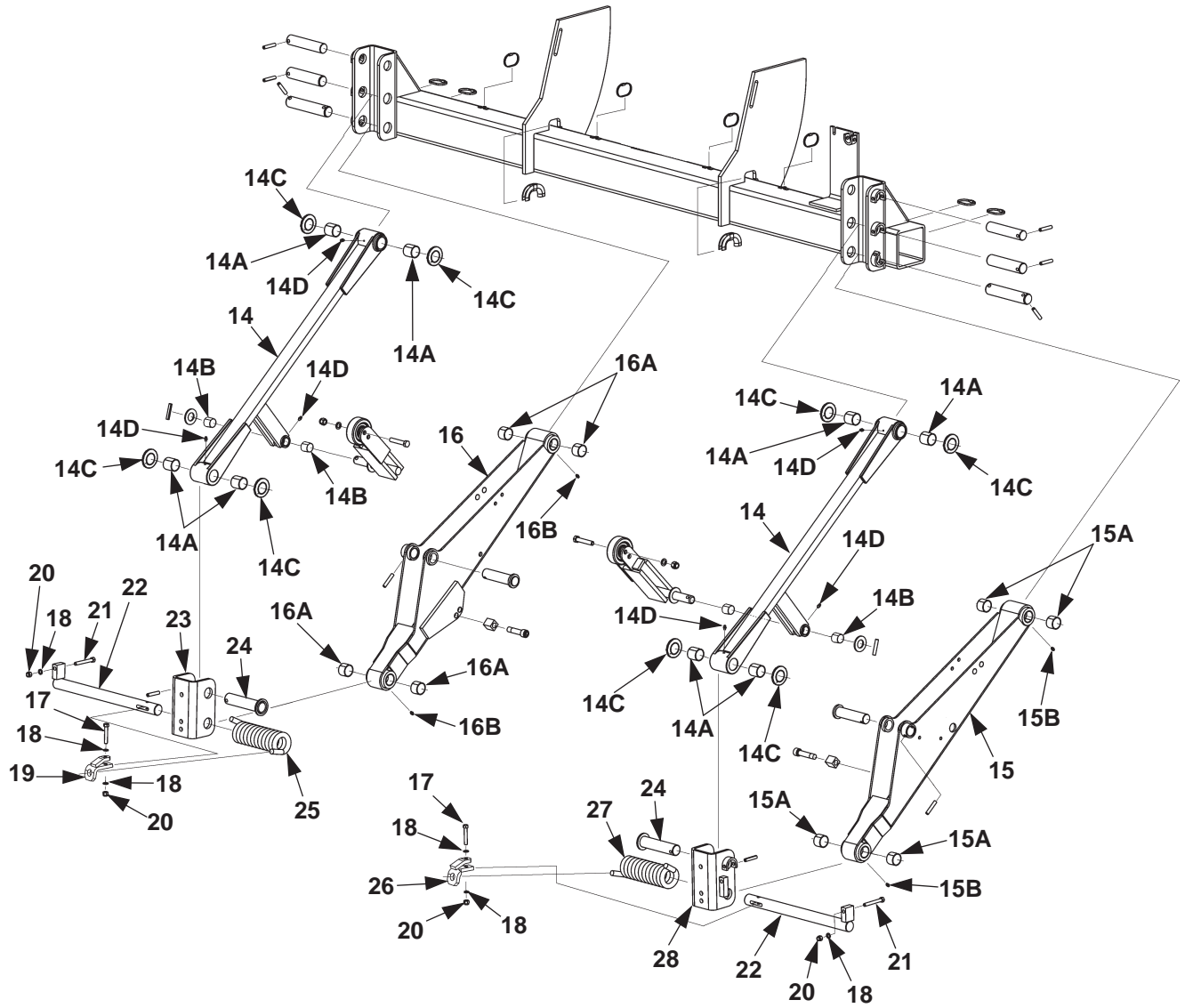

ITEM	QTY.	PART NO.	DESCRIPTION
14	2	280912-01	PARALLEL ARMS
14A	4	908065-04	BEARING, SELF-LUBE, 1-1/2" LG.
14B	2	908045-02	BEARING, SELF-LUBE, 3/4" LG.
14C	4	908059-01	BEARING, THRUST
14D	3	224342	LUBE FITTING
15	1	280915-01	LIFT ARM, RH
15A	4	908047-02	BEARING, SELF-LUBE
15B	2	224342	LUBE FITTING
16	1	280915-02	LIFT ARM, LH
16A	4	908047-02	BEARING, SELF-LUBE
16B	2	224342	LUBE FITTING
17	2	900014-10	CAP SCREW, 3/8"-16 X 2-1/2" LG., GRADE 8
18	6	902000-10	FLAT WASHER, 3/8"
19	1	281515-02	BRACKET, REINFORCEMENT, LH
20	4	901002	LOCK NUT, 3/8"-16
21	2	900014-11	CAP SCREW, 3/8"-16 X 3" LG.
22	2	281004-01	PIN, SPRING
23	1	280971-02	SHACKLE, LH
24	2	280976-01	PIN, 6" LG.
25	1	280950-02	TORSION SPRING, LH (ALUMINUM PLATFORM)
		281319-02	TORSION SPRING, LH (STEEL PLATFORM)
26	1	281515-01	BRACKET, REINFORCEMENT, RH
27	1	280950-01	TORSION SPRING, RH (ALUMINUM PLATFORM)
		281319-01	TORSION SPRING, RH (STEEL PLATFORM)
28	1	280971-01	SHACKLE, RH

MAIN FRAME, LIFTING ARMS, & PARALLEL ARMS: GPTLR-44 & GPTLR-55

MAXON

11921 Slauson Ave. Santa Fe Springs, CA. 90670 (800) 227-4116 FAX (888) 771-7713

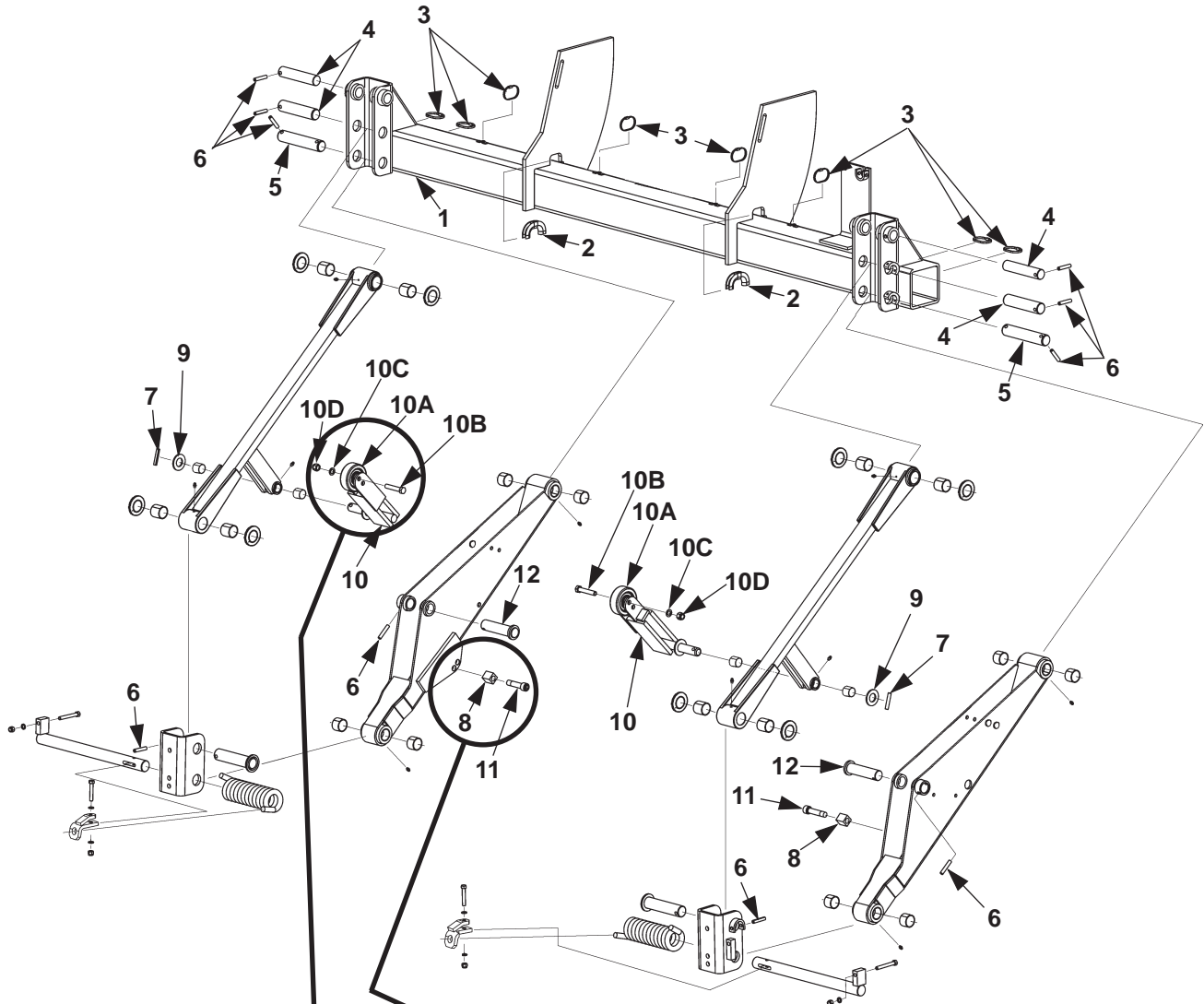

**POSITION #2 FOR
44"- 49" BED HEIGHT**

**POSITION #2 FOR
53"- 55" BED HEIGHT**

**POSITION #1 FOR
49"- 55" BED HEIGHT**

**POSITION #1 FOR
44"- 53" BED HEIGHT**

OPENER ROLLER POSITIONS

SLIDER POSITIONS

ITEM	QTY.	PART NO.	DESCRIPTION
1	1	281018-01	MAIN FRAME (96" WIDE GPTLR-44/55)
		281018-02	MAIN FRAME (102" WIDE GPTLR-44/55)
2	2	040103-5	SPLIT LOOM, 1/2" X 5" LG.
3	8	905322-01	PLASTIC TIE, 8" LG.
4	4	280968-04	PIN, 1-3/8" DIA X 7-1/8" LG.
5	2	281005-01	PIN, 8-1/16" LG.
6	10	904717-08	ROLL PIN, 3/8" X 2-1/2" LG.
7	2	221416	ROLL PIN, 3/8" X 2" LG.
8	2	281643-01	SLIDER
9	2	902013-18	FLAT WASHER, 1-1/16"
10	2	281701-01	OPENER
10A	2	280082-01	ROLLER
10B	2	900035-8	CAP SCREW, 1/2"-13 X 2-3/4" LG.
10C	2	902000-14	FLAT WASHER, 1/2"
10C	2	901010	LOCK NUT, 1/2"-13
11	2	281644-01	PIN, SOCKET HEAD
12	2	281127-01	PIN, CYLINDER

MAIN FRAME, LIFTING ARMS, & PARALLEL ARMS: GPTLR-44 & GPTLR-55 - Continued

MAXON[®]

11921 Slauson Ave. Santa Fe Springs, CA. 90670 (800) 227-4116 FAX (888) 771-7713

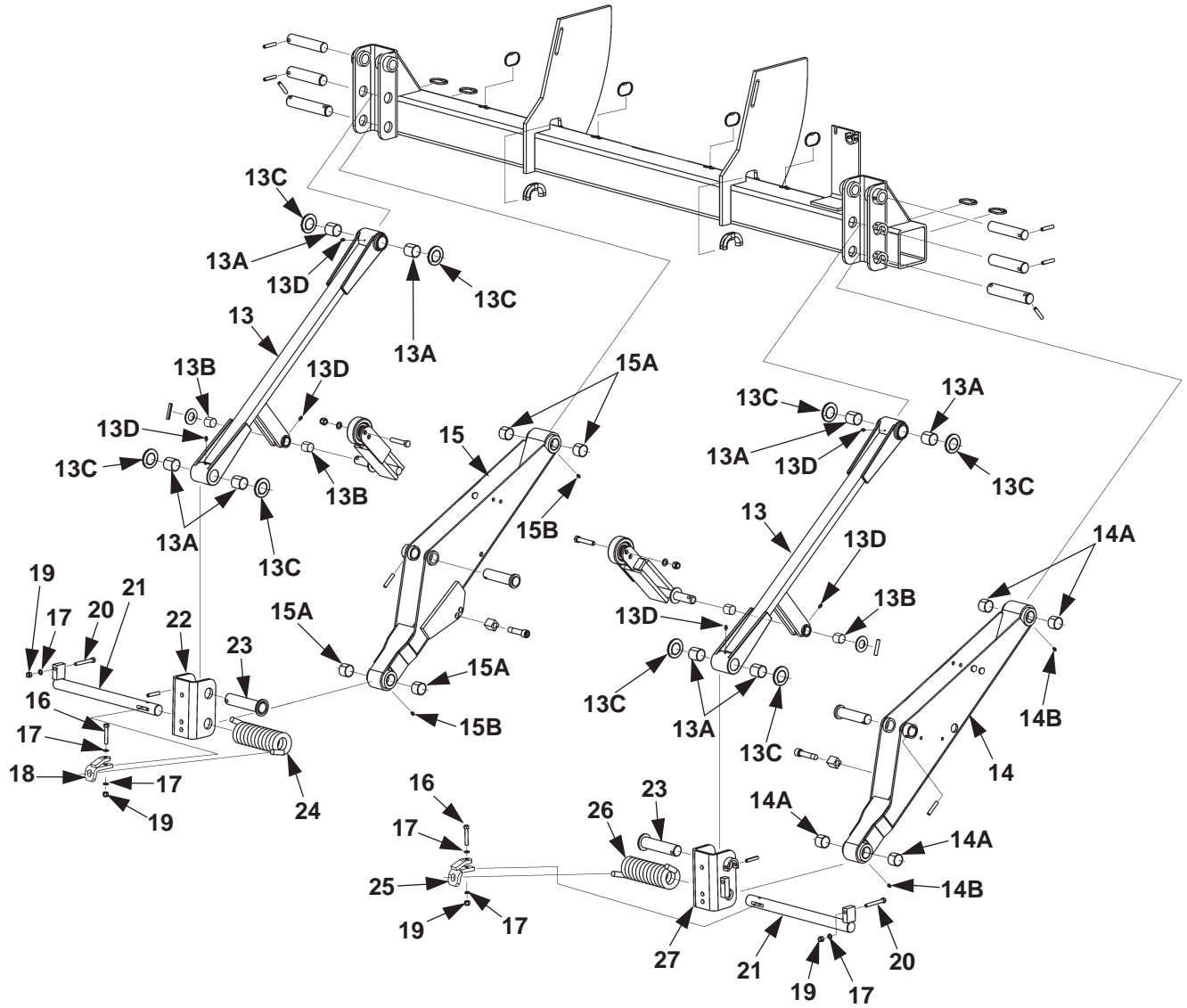

ITEM	QTY.	PART NO.	DESCRIPTION
13	2	281042-01	PARALLEL ARMS
13A	4	908065-04	BEARING, SELF-LUBE, 1-1/2" LG.
13B	2	908045-02	BEARING, SELF-LUBE, 3/4" LG.
13C	4	908059-01	BEARING, THRUST
13D	3	224342	LUBE FITTING
14	1	281025-01	LIFT ARM, RH
14A	4	908047-02	BEARING, SELF-LUBE
14B	2	224342	LUBE FITTING
15	1	281025-02	LIFT ARM, LH
15A	4	908047-02	BEARING, SELF-LUBE
15B	2	224342	LUBE FITTING
16	2	900014-10	CAP SCREW, 3/8"-16 X 2-1/2" LG., GRADE 8
17	6	902000-10	FLAT WASHER, 3/8"
18	1	281515-02	BRACKET, REINFORCEMENT, LH
19	4	901002	LOCK NUT, 3/8"-16
20	2	900014-11	CAP SCREW, 3/8"-16 X 3" LG.
21	2	281053-01	PIN, SPRING
22	1	281033-02	SHACKLE, LH
23	2	280976-02	PIN, 7" LG.
24	1	280950-02	TORSION SPRING, LH (ALUMINUM PLATFORM)
25	1	281515-01	BRACKET, REINFORCEMENT, RH
26	1	280950-01	TORSION SPRING, RH (ALUMINUM PLATFORM)
27	1	281033-01	SHACKLE, RH

LH & RH PLATFORM SEATS: GPTLR-25 & GPTLR-33 (ALUMINUM PLATFORM WITH FIXED RAMP OR CART STOPS ONLY)

MAXON[®]

11921 Slauson Ave. Santa Fe Springs, CA. 90670 (800) 227-4116 FAX (888) 771-7713

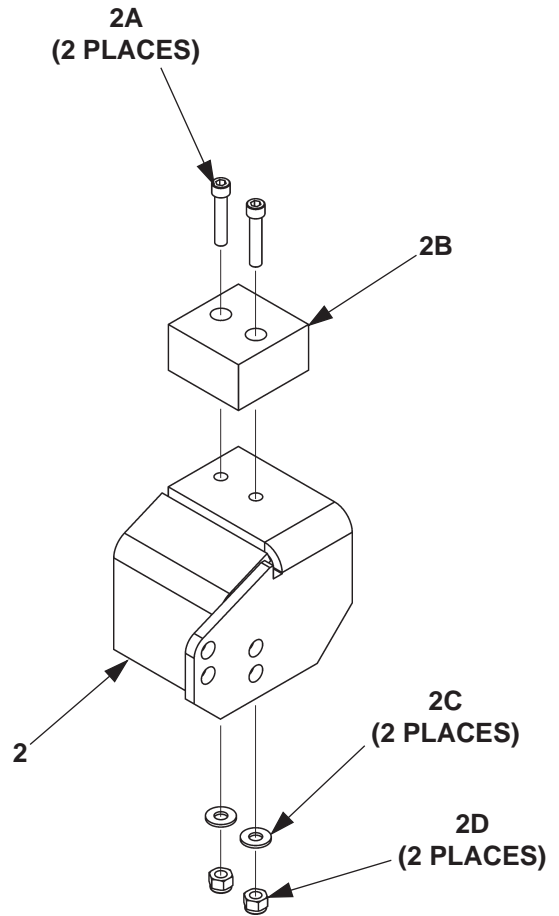
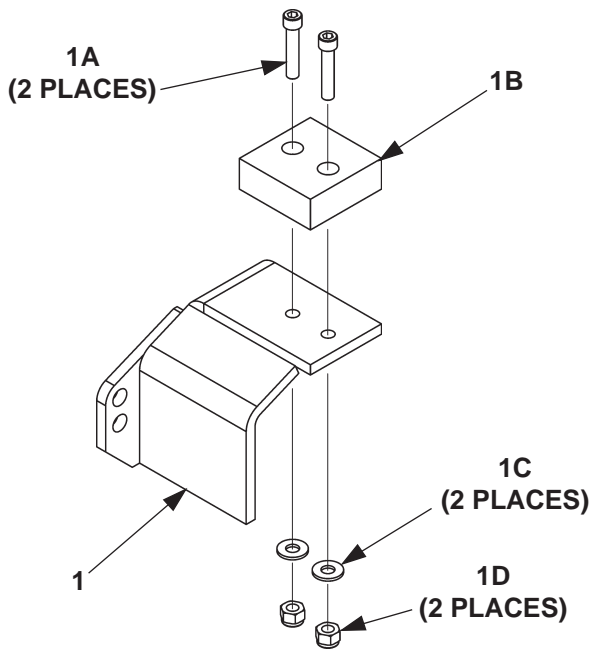

ITEM	QTY.	PART NO.	DESCRIPTION
1	1	281650-02	PLATFORM SEAT, LH (1/2" THICK PAD)
1A	2	900025-1	SOCKET SCREW, 1/4"-20 X 1" LG.
1B	1	281649-01	PLASTIC PAD (1/2" THICK PAD)
1C	2	902013-09	FLAT WASHER, 1/4"
1D	2	901000	LOCK NUT, 1/4"-20
2	1	281653-01	PLATFORM SEAT, RH (3/4" THICK PAD)
2A	2	900025-1	SOCKET SCREW, 1/4"-20 X 1" LG.
2B	1	281652-01	PLASTIC PAD (3/4" THICK PAD)
2C	2	902013-09	FLAT WASHER, 1/4"
2D	2	901000	LOCK NUT, 1/4"-20

LH & RH PLATFORM SEATS: GPTLR-25 & GPTLR-33 (ALUMINUM PLATFORM WITH RETENTION RAMP ONLY)

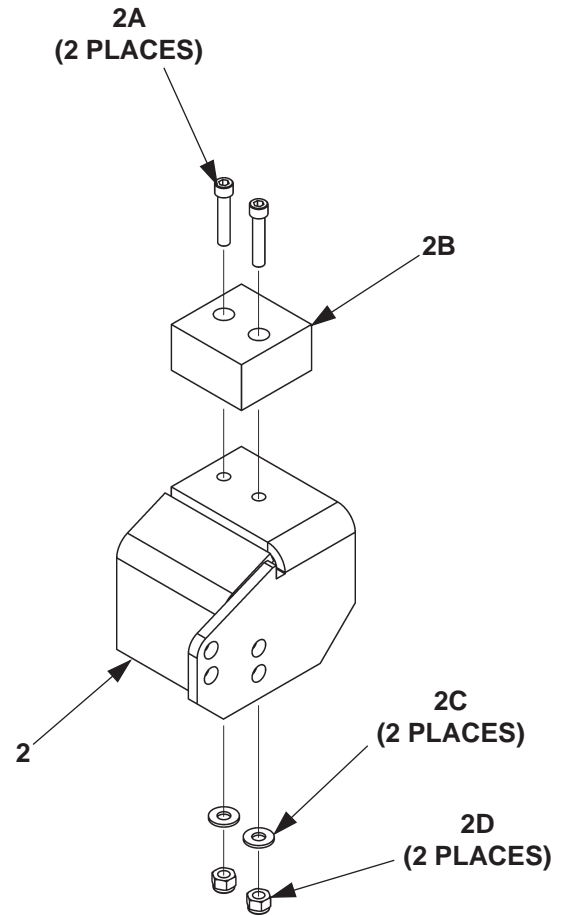
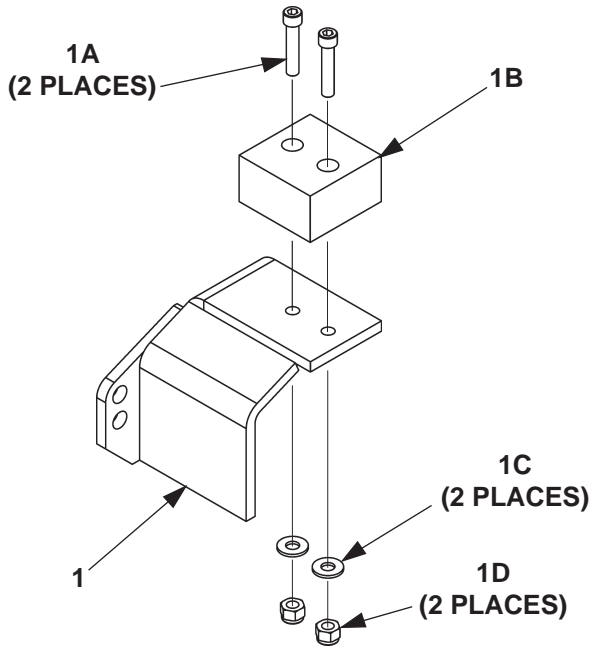

ITEM	QTY.	PART NO.	DESCRIPTION
1	1	281653-02	PLATFORM SEAT, LH (3/4" THICK PAD)
1A	2	900025-1	SOCKET SCREW, 1/4"-20 X 1" LG.
1B	1	281652-01	PLASTIC PAD (3/4" THICK PAD)
1C	2	902013-09	FLAT WASHER, 1/4"
1D	2	901000	LOCK NUT, 1/4"-20
2	1	281653-01	PLATFORM SEAT, RH (3/4" THICK PAD)
2A	2	900025-1	SOCKET SCREW, 1/4"-20 X 1" LG.
2B	1	281652-01	PLASTIC PAD (3/4" THICK PAD)
2C	2	902013-09	FLAT WASHER, 1/4"
2D	2	901000	LOCK NUT, 1/4"-20

LH & RH PLATFORM SEATS: GPTLR-25 & GPTLR-33 (STEEL PLATFORM ONLY)

MAXON®

11921 Slauson Ave. Santa Fe Springs, CA. 90670 (800) 227-4116 FAX (888) 771-7713

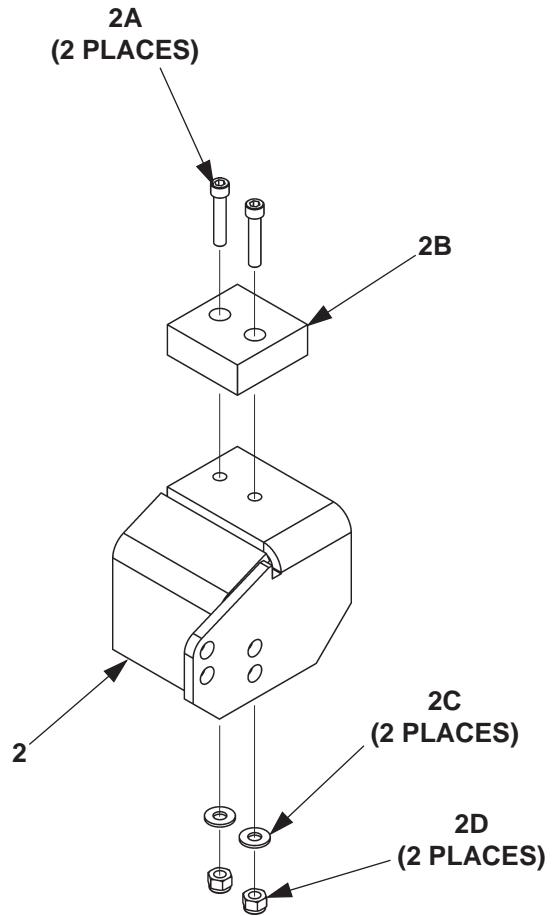
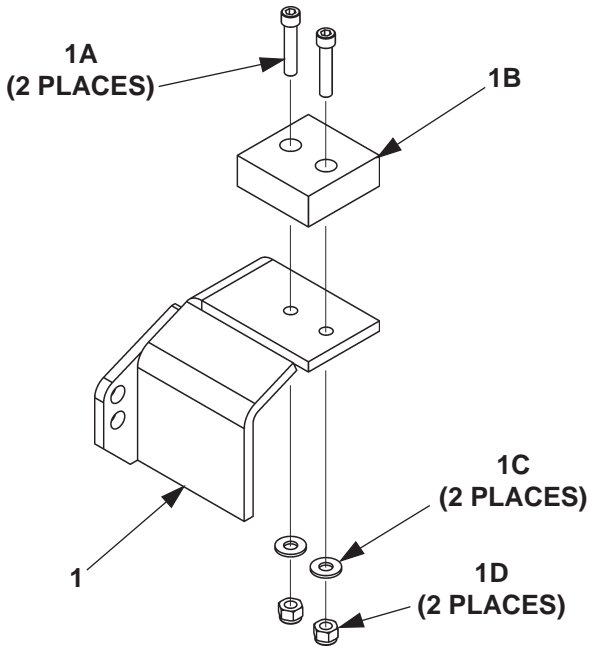

ITEM	QTY.	PART NO.	DESCRIPTION
1	1	281650-02	PLATFORM SEAT, LH (1/2" THICK PAD)
1A	2	900025-1	SOCKET SCREW, 1/4"-20 X 1" LG.
1B	1	281649-01	PLASTIC PAD (1/2" THICK PAD)
1C	2	902013-09	FLAT WASHER, 1/4"
1D	2	901000	LOCK NUT, 1/4"-20
2	1	281650-01	PLATFORM SEAT, RH (1/2" THICK PAD)
2A	2	900025-1	SOCKET SCREW, 1/4"-20 X 1" LG.
2B	1	281649-01	PLASTIC PAD (1/2" THICK PAD)
2C	2	902013-09	FLAT WASHER, 1/4"
2D	2	901000	LOCK NUT, 1/4"-20

**LH & RH PLATFORM SEATS: GPTLR-44 & GPTLR-55
(ONLY ALUMINUM PLATFORM WITH FIXED RAMP OR CART STOPS)**

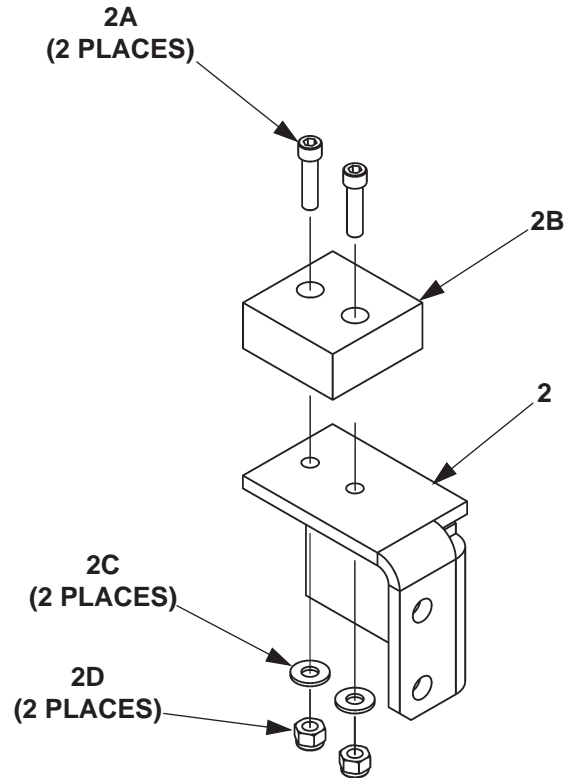
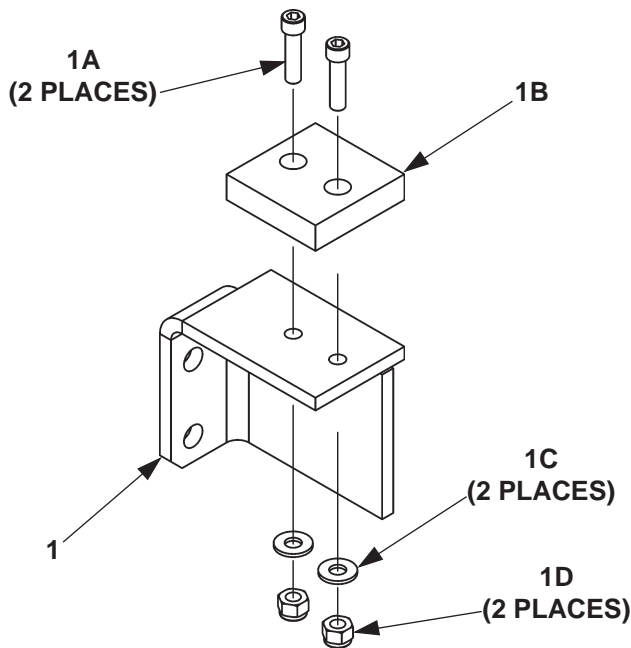

ITEM	QTY.	PART NO.	DESCRIPTION
1	1	281698-02	PLATFORM SEAT, LH (1/2" THICK PAD)
1A	2	900025-1	SOCKET SCREW, 1/4"-20 X 1" LG.
1B	1	281649-01	PLASTIC PAD (1/2" THICK PAD)
1C	2	902013-09	FLAT WASHER, 1/4"
1D	2	901000	LOCK NUT, 1/4"-20
2	1	281716-01	PLATFORM SEAT, RH (3/4" THICK PAD)
2A	2	900025-1	SOCKET SCREW, 1/4"-20 X 1" LG.
2B	1	281649-01	PLASTIC PAD (3/4" THICK PAD)
2C	2	902013-09	FLAT WASHER, 1/4"
2D	2	901000	LOCK NUT, 1/4"-20

LH & RH PLATFORM SEATS: GPTLR-44 & GPTLR-55 (ONLY PLATFORM WITH RETENTION RAMP)

MAXON®

11921 Slauson Ave. Santa Fe Springs, CA. 90670 (800) 227-4116 FAX (888) 771-7713

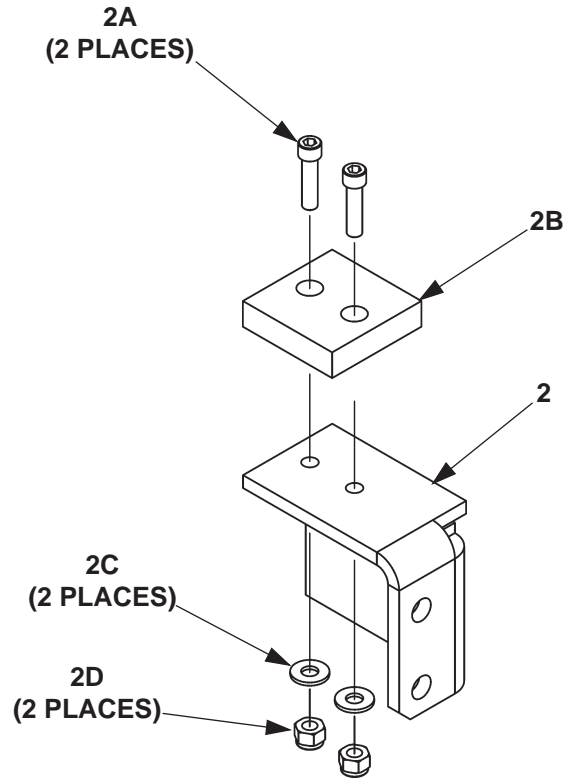
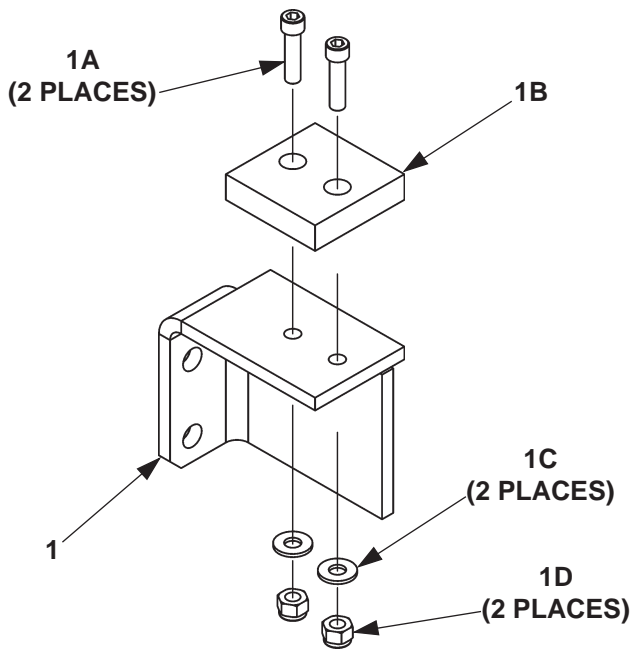

ITEM	QTY.	PART NO.	DESCRIPTION
1	1	281698-02	PLATFORM SEAT, LH (1/2" THICK PAD)
1A	2	900025-1	SOCKET SCREW, 1/4"-20 X 1" LG.
1B	1	281649-01	PLASTIC PAD (1/2" THICK PAD)
1C	2	902013-09	FLAT WASHER, 1/4"
1D	2	901000	LOCK NUT, 1/4"-20
2	1	281698-01	PLATFORM SEAT, RH (1/2" THICK PAD)
2A	2	900025-1	SOCKET SCREW, 1/4"-20 X 1" LG.
2B	1	281649-01	PLASTIC PAD (1/2" THICK PAD)
2C	2	902013-09	FLAT WASHER, 1/4"
2D	2	901000	LOCK NUT, 1/4"-20

THIS PAGE INTENTIONALLY LEFT BLANK

PLATFORM & FLIPOVER ASSEMBLY (ALUMINUM)

MAXON®

11921 Slauson Ave. Santa Fe Springs, CA. 90670 (800) 227-4116 FAX (888) 771-7713

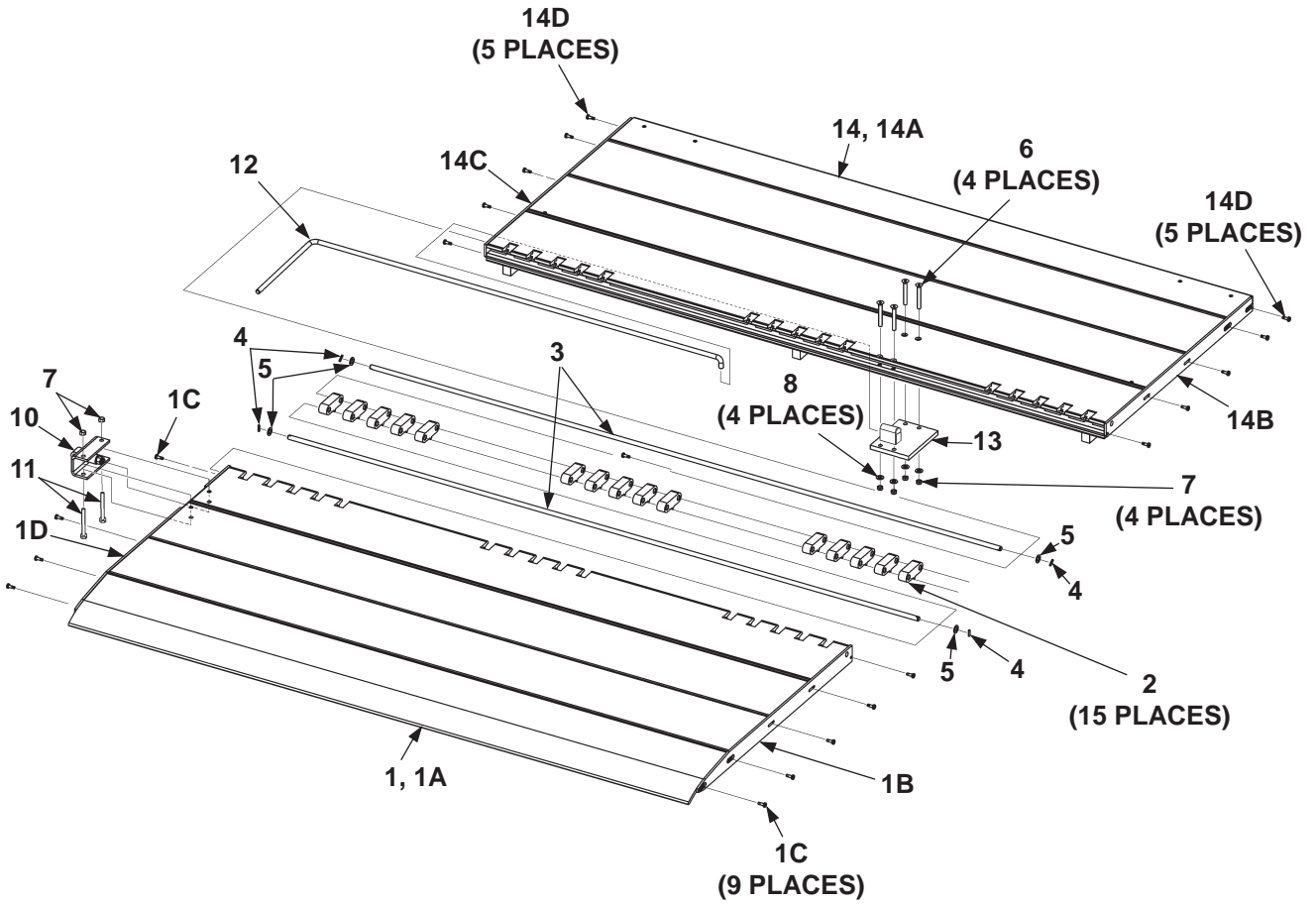

ITEM	QTY.	PART NO.	DESCRIPTION
1	1	281145-01	FLIPOVER ASSEMBLY, 79-1/2" (WIDE)
		281145-02	FLIPOVER ASSEMBLY, 85-1/2" (WIDE)
1A	1	281142-01	FLIPOVER WELDMENT, 79" (WIDE)
		281142-02	FLIPOVER WELDMENT, 85" (WIDE)
1B	1	281635-01	SIDE PLATE, FLIPOVER RH
1C	9	900705-01	SELF-TAPPING SCREW, 1/4"-20 X 1" LG.
1D	1	281636-01	SIDE PLATE, FLIPOVER LH
2	15	281010-01	HINGE ASSEMBLY
3	2	263456-12	HINGE, ROD, 80" LG. (79-1/2" WIDE PLATFORM)
		263456-13	HINGE, ROD, 86" LG. (85-1/2" WIDE PLATFORM)
4	4	905015-1	ROLL PIN, 3/16" X 3/4" LG.
5	4	902000-14	FLAT WASHER, 1/2"
6	4	900040-11	FLAT HEAD SOCKET SCREW, 3/8"-16 X 3" LG.
7	6	901016-4	LOCK NUT, THIN HEAD, 3/8"-16
8	4	902013-11	FLAT WASHER, 3/8"
9	2	901002	LOCK NUT, 3/8"-16
10	1	281135-01	TORSION BAR BRACKET
11	2	900014-20	CAP SCREW, 3/8"-16 X 3-1/4" LG.
12	1	281141-01	TORSION BAR
13	1	281410-01	TORSION BAR HOLDER
14	1	281330-01	PLATFORM ASSEMBLY, 79-1/2" (WIDE)
		281330-02	PLATFORM ASSEMBLY, 85-1/2" (WIDE)
14A	1	281144-01	PLATFORM WELDMENT, 79" (WIDE)
		281144-02	PLATFORM WELDMENT, 85" (WIDE)
14B	1	280987-01	SIDE PLATE, RH, PLATFORM
14C	1	281143-01	SIDE PLATE, LH, PLATFORM
14D	10	900705-01	SELF-TAPPING SCREW, 1/4"-20 X 1" LG.

ITEM	QTY.	PART NO.	DESCRIPTION
1	1	281410-01	TORSION BAR HOLDER
2	15	281010-01	HINGE ASSEMBLY
3	2	263456-12	HINGE, ROD, 80" LG. (79-1/2" WIDE PLATFORM)
		263456-13	HINGE, ROD, 86" LG. (85-1/2" WIDE PLATFORM)
4	4	905015-1	ROLL PIN, 3/16" X 3/4" LG.
5	4	902000-14	FLAT WASHER, 1/2"
6	4	900040-11	FLAT HEAD SOCKET SCREW, 3/8"-16 X 3" LG.
7	6	901016-4	LOCK NUT, THIN HEAD, 3/8"-16
8	6	902013-11	FLAT WASHER, 3/8"
9	1	281141-01	TORSION BAR
10	1	281135-01	TORSION BAR BRACKET
11	2	900014-11	CAP SCREW, 3/8"-16 X 3" LG.
12	1	281130-01	PLATFORM ASSEMBLY, 79-1/2" (WIDE)
		281130-02	PLATFORM ASSEMBLY, 85-1/2" (WIDE)
12A	1	281144-01	PLATFORM WELDMENT, 79" (WIDE)
		281144-02	PLATFORM WELDMENT, 85" (WIDE)
12B	1	280987-01	SIDE PLATE, RH, PLATFORM
12C	1	281143-01	SIDE PLATE, LH, PLATFORM
12D	10	900705-01	85-1/2" (WIDE) SELF-TAPPING SCREW, 1/4"-20 X 1" LG.

FLIPOVER WITH SINGLE CART STOP (ALUMINUM)

MAXON[®]

11921 Slauson Ave. Santa Fe Springs, CA. 90670 (800) 227-4116 FAX (888) 771-7713

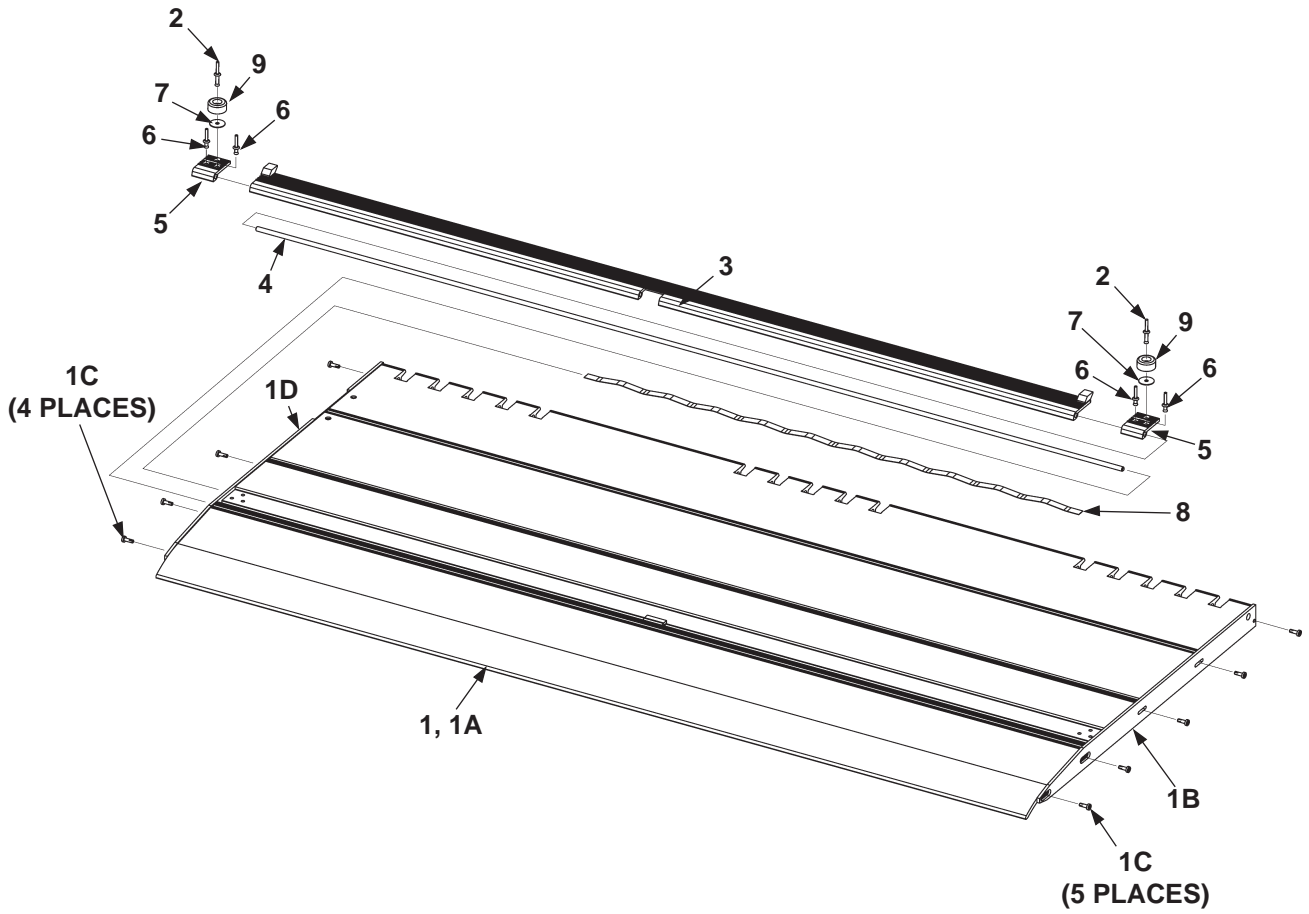

ITEM	QTY.	PART NO.	DESCRIPTION
1	1	267055-03	FLIPOVER ASSEMBLY, 79-1/2" (WIDE)
		267055-04	FLIPOVER ASSEMBLY, 85-1/2" (WIDE)
1A	1	267087-01	FLIPOVER WELDMENT, 79" (WIDE)
		267087-02	FLIPOVER WELDMENT, 85" (WIDE)
1B	1	281635-01	SIDE PLATE, FLIPOVER RH
1C	9	900705-01	SELF-TAPPING SCREW, 1/4"-20 X 1" LG.
1D	1	281636-01	SIDE PLATE, FLIPOVER LH
2	2	903705-06	RIVET, BLIND, 1/4" X 1-7/32" LG.
3	1	267092-08	CART STOP WELDMENT RH, 75" (WIDE)
		267092-09	CART STOP WELDMENT RH, 81" (WIDE)
4	1	267094-01	PIN, 78-3/4" LG. (79-1/2" WIDE FLIPOVER)
		267094-02	PIN, 84-3/4" LG. (85-1/2" WIDE FLIPOVER)
5	2	267088-01	CART STOP LINK
6	4	903705-02	RIVET, BLIND, 1/4" X 5/8" LG.
7	2	903409-07	FENDER WASHER, 9/32" X 1-1/4" O.D.
8	1	267581-01	SPRING, FLIPOVER, 42" LG.
9	2	905314-05	BUMPER

FLIPOVER WITH DUAL CART STOPS (ALUMINUM)

MAXON®

11921 Slauson Ave. Santa Fe Springs, CA. 90670 (800) 227-4116 FAX (888) 771-7713

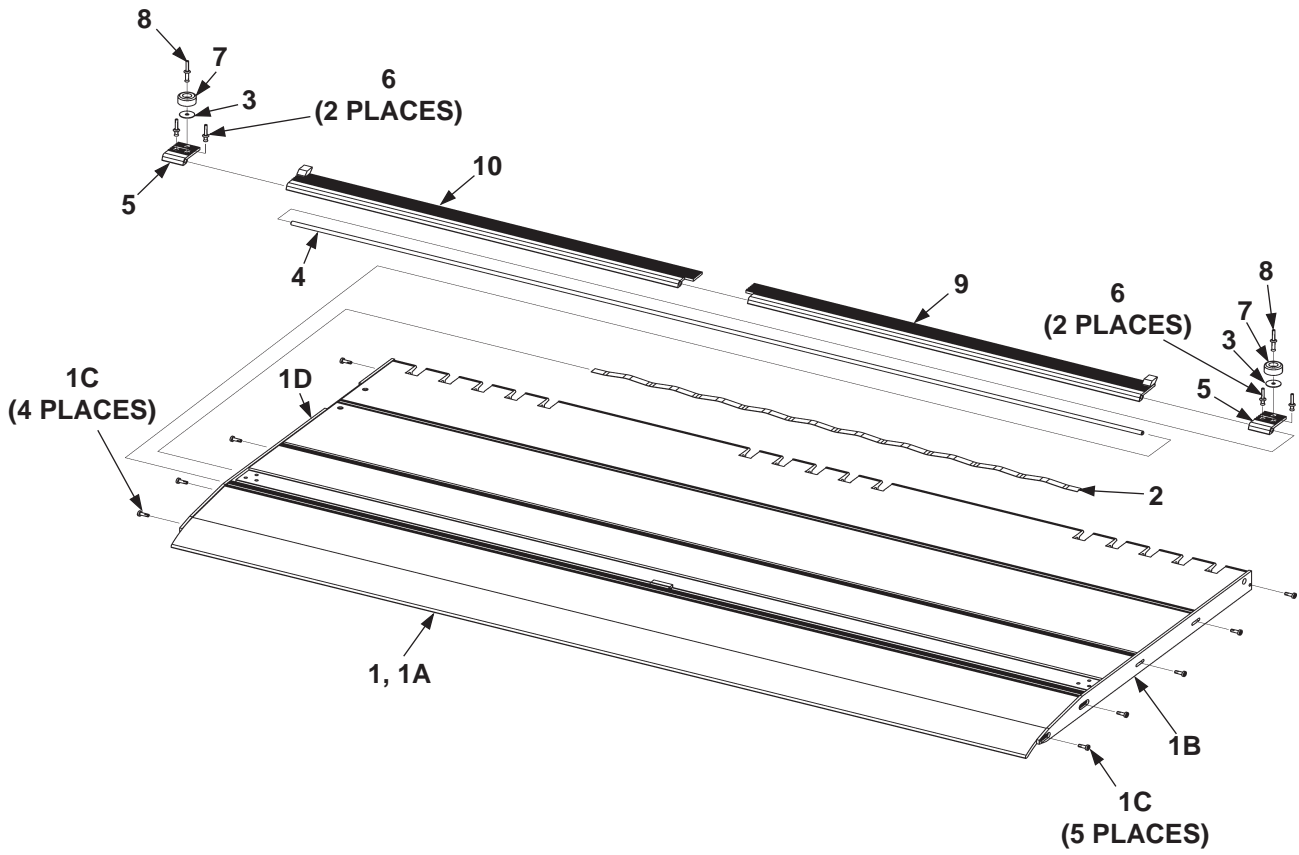

ITEM	QTY.	PART NO.	DESCRIPTION
1	1	267055-01	FLIPOVER ASSEMBLY, 79-1/2" (WIDE)
		267055-02	FLIPOVER ASSEMBLY, 85-1/2" (WIDE)
1A	1	267087-01	FLIPOVER WELDMENT, 79" (WIDE)
		267087-02	FLIPOVER WELDMENT, 85" (WIDE)
1B	1	281635-01	SIDE PLATE, FLIPOVER RH
1C	9	900705-01	SELF-TAPPING SCREW, 1/4"-20 X 1" LG.
1D	1	281636-01	SIDE PLATE, FLIPOVER LH
2	1	267581-01	SPRING, FLIPOVER, 42" LG.
3	2	903409-07	FENDER WASHER, 9/32" X 1-1/4" O.D.
4	1	267094-01	PIN, 78-3/4" LG. (79-1/2" WIDE FLIPOVER)
		267094-02	PIN, 84-3/4" LG. (85-1/2" WIDE FLIPOVER)
5	2	267088-01	CART STOP LINK
6	2	903705-02	RIVET, BLIND, 1/4" X 5/8" LG.
7	2	905314-05	BUMPER
8	2	903705-06	RIVET, BLIND, 1/4" X 1-7/32" LG.
9	1	267092-04	CART STOP WELDMENT RH, 36-3/8" (WIDE)
		267092-06	CART STOP WELDMENT RH, 39-3/8" (WIDE)
10	1	267092-05	CART STOP WELDMENT LH, 36-3/8" (WIDE)
		267092-07	CART STOP WELDMENT LH, 39-3/8" (WIDE)

MAXON[®] 11921 Slauson Ave. Santa Fe Springs, CA. 90670 (800) 227-4116 FAX (888) 771-7713

PLATFORM & FLIPOVER ASSEMBLY WITH SINGLE RETENTION RAMP (ALUMINUM)

NOTE: This Platform & Flipover with Retention Ramp is only available for GPTLR-44 & GPTLR-55.

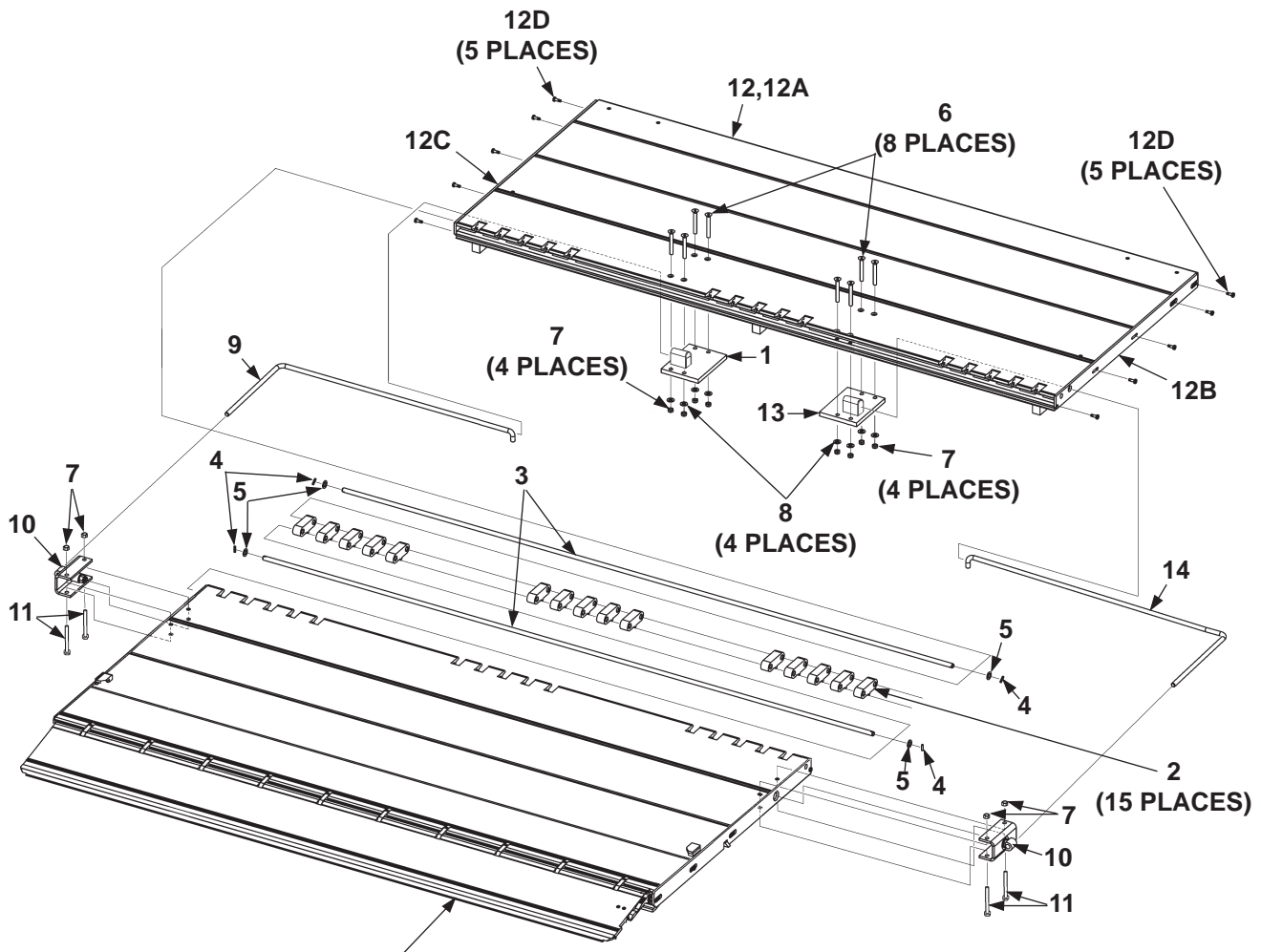

REFER TO FLIPOVER WITH
SINGLE RETENTION RAMP

MAXON®

11921 Slauson Ave. Santa Fe Springs, CA. 90670 (800) 227-4116 FAX (888) 771-7713

ITEM	QTY.	PART NO.	DESCRIPTION
1	1	281410-01	TORSION BAR HOLDER, LH
2	15	281010-01	HINGE ASSEMBLY
3	2	263456-12	HINGE, ROD, 80" LG. (79-1/2" WIDE PLATFORM)
		263456-13	HINGE, ROD, 86" LG. (85-1/2" WIDE PLATFORM)
4	4	905015-1	ROLL PIN, 3/16" X 3/4" LG.
5	4	902000-14	FLAT WASHER, 1/2"
6	8	900040-11	FLAT HEAD SOCKET SCREW, 3/8"-16 X 3" LG.
7	12	901016-4	LOCK NUT, THIN HEAD, 3/8"-16
8	8	902013-11	FLAT WASHER, 3/8"
9	1	281414-01	TORSION BAR, LH
10	2	281135-01	TORSION BAR BRACKET
11	4	900014-11	CAP SCREW, 3/8"-16 X 3" LG.
12	1	281330-03	PLATFORM ASSEMBLY, 79-1/2" (WIDE)
		281330-04	PLATFORM ASSEMBLY, 85-1/2" (WIDE)
12A	1	281144-03	PLATFORM WELDMENT, 79" (WIDE)
		281144-04	PLATFORM WELDMENT, 85" (WIDE)
12B	1	281143-02	SIDE PLATE, RH, PLATFORM
12C	1	281143-01	SIDE PLATE, LH, PLATFORM
12D	10	900705-01	SELF-TAPPING SCREW, 1/4"-20 X 1" LG.
13	1	281410-02	TORSION BAR HOLDER, RH
14	1	281414-02	TORSION BAR, RH

FLIPOVER WITH SINGLE RETENTION RAMP (ALUMINUM)

MAXON[®]

11921 Slauson Ave. Santa Fe Springs, CA. 90670 (800) 227-4116 FAX (888) 771-7713

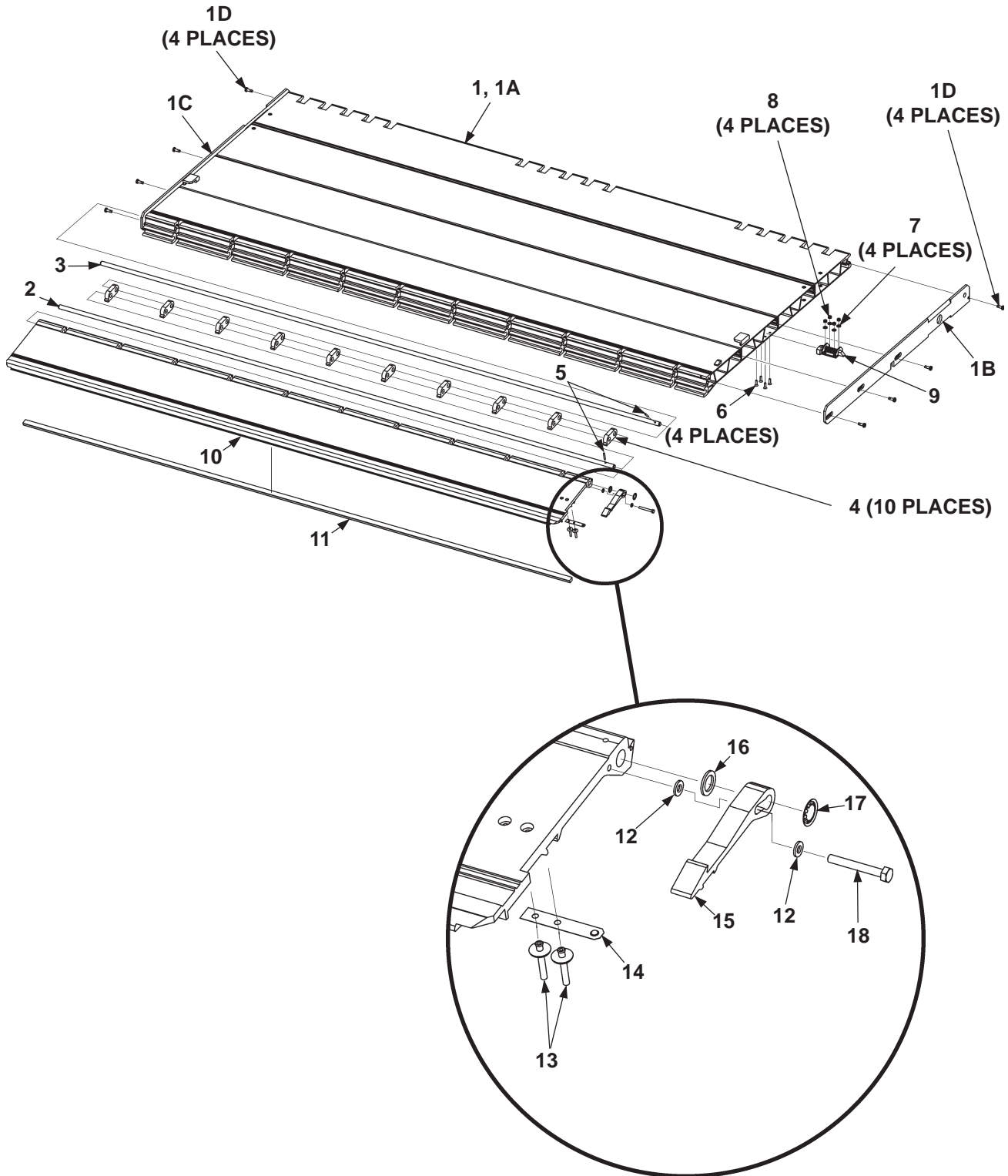

ITEM	QTY.	PART NO.	DESCRIPTION
1	1	267051-01	FLIPOVER ASSEMBLY, 79-1/2" (WIDE)
		267051-02	FLIPOVER ASSEMBLY, 85-1/2" (WIDE)
1A	1	267052-01	FLIPOVER WELDMENT, 79-1/2" (WIDE)
		267052-02	FLIPOVER WELDMENT, 85-1/2" (WIDE)
1B	1	267044-01	SIDE PLATE, FLIPOVER RH
1C	1	267044-02	SIDE PLATE, FLIPOVER LH
1D	8	900705-01	SELF-TAPPING SCREW, 1/4"-20 X 1" LG.
2	1	267045-01	HINGE, ROD, 78-1/4" LG. (79-1/2" WIDE FLIPOVER)
		267045-03	HINGE, ROD, 84-1/4" LG. (85-1/2" WIDE FLIPOVER)
3	1	267045-02	HINGE, ROD, 78-3/4" LG. (79-1/2" WIDE FLIPOVER)
		267045-04	HINGE, ROD, 84-3/4" LG. (85-1/2" WIDE FLIPOVER)
4	10	311022-10	HINGE ASSEMBLY
5	2	905007-07	ROLL PIN, 5/32" X 1" LG.
6	4	900028-3	PAN HEAD SCREW, #10-24 X 3/4" LG.
7	4	902013-07	FLAT WASHER, #10
8	4	901003	NYLON NUT, #10-24
9	1	267201-02	SLAM-LATCH
10	1	267041-01	RETENTION RAMP, 78" (WIDE)
		267041-02	RETENTION RAMP, 84" (WIDE)
11	1	905318-01	BUMPER
12	2	903421-02	FLAT WASHER, 1/4", NYLON
13	2	904005-1	RIVET, 3/16" DIA. X 7/16" LG.
14	1	267326-01	RETENTION RAMP SPRING HOOK
15	1	311038-11	RETENTION RAMP HOOK
16	1	903413-02	NYLON WASHER, 1/2", 1/16" THICK
17	1	903420-01	SELF-LOCKING RETENTION RING, 1/2"
18	1	900004-8	CAP SCREW, 1/4"-20 X 2" LG.

PLATFORM & FLIPOVER ASSEMBLY (STEEL)

NOTE: This Steel Platform & Flipover Assembly is only available for GPTLR-25 & GPTLR-33.

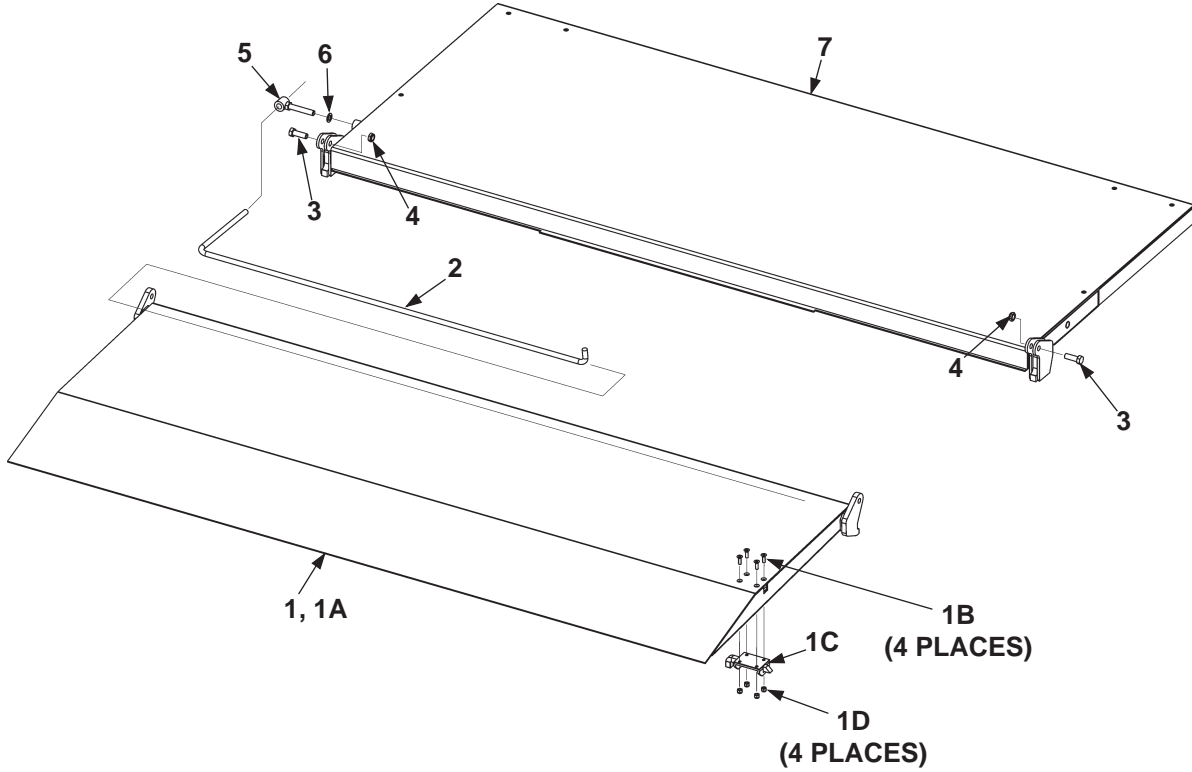

ITEM	QTY.	PART NO.	DESCRIPTION
1	1	267301-01	FLIPOVER ASSEMBLY, 79" (WIDE)
		267301-02	FLIPOVER ASSEMBLY, 85" (WIDE)
1A	1	267820-01	FLIPOVER WELDMENT, 79" (WIDE)
		267820-02	FLIPOVER WELDMENT, 85" (WIDE)
1B	4	900044-5	SOCKET SCREW, 1/4"-20 X 7/8" LG..
1C	1	267201-03	SLAM-LATCH
1D	4	901000	LOCK NUT, 1/4"-20
2	1	281302-01	TORSION BAR
3	2	900033-3	CAP SCREW, 1/2"-20 X 1-1/2" LG.
4	2	901016-1	LOCK NUT, 1/2"-20
5	1	280749-01	ANCHOR BOLT
6	1	902000-14	FLAT WASHER, 1/2"
7	1	267825-01	PLATFORM WELDMENT, 79" (WIDE)
		267825-02	PLATFORM WELDMENT, 85" (WIDE)

MAXON®

11921 Slauson Ave. Santa Fe Springs, CA. 90670 (800) 227-4116 FAX (888) 771-7713

PUMP COVER & MOUNTING PLATE ASSEMBLY

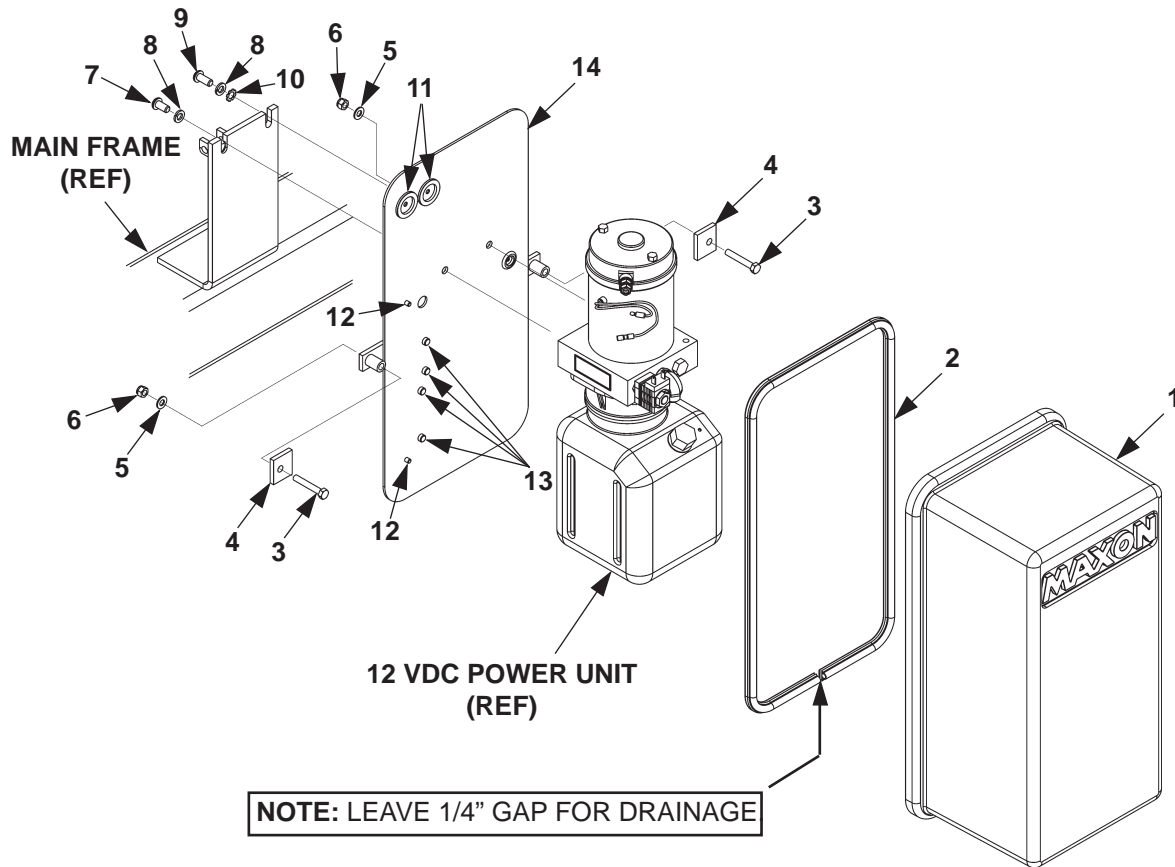

ITEM	QTY.	PART NO.	DESCRIPTION
1	1	281038-01	COVER ASSY
2	1	093203-10	GASKET, RUBBER CHANNEL, 60" LG.
3	2	90009-8	CAP SCREW, 5/16"-18 X 2" LG.
4	2	281062-02	HOLDER FLATS
5	2	902013-10	FLAT WASHER, 5/16"
6	2	901001	LOCK NUT, 5/16"-18
7	1	900064-03	BUTTONHEAD SCREW, 3/8"-16 X 3/4" LG.
8	2	902011-4	LOCK WASHER, 3/8"
9	1	900064-04	BUTTONHEAD SCREW, 3/8"-16 X 7/8" LG.
10	1	903400-02	LOCK WASHER, EXTERNAL TOOTH
11	2	266428-02	GROMMET, 1/4"HOLE
12	2	908022-01	PLUG, FLEXIBLE
13	4	908022-03	PLUG, FLEXIBLE
14	1	281065-01	PLATE, PUMP MOUNT

MAXON[®] 11921 Slauson Ave. Santa Fe Springs, CA. 90670 (800) 227-4116 FAX (888) 771-7713

GRAVITY DOWN HYDRAULIC COMPONENTS

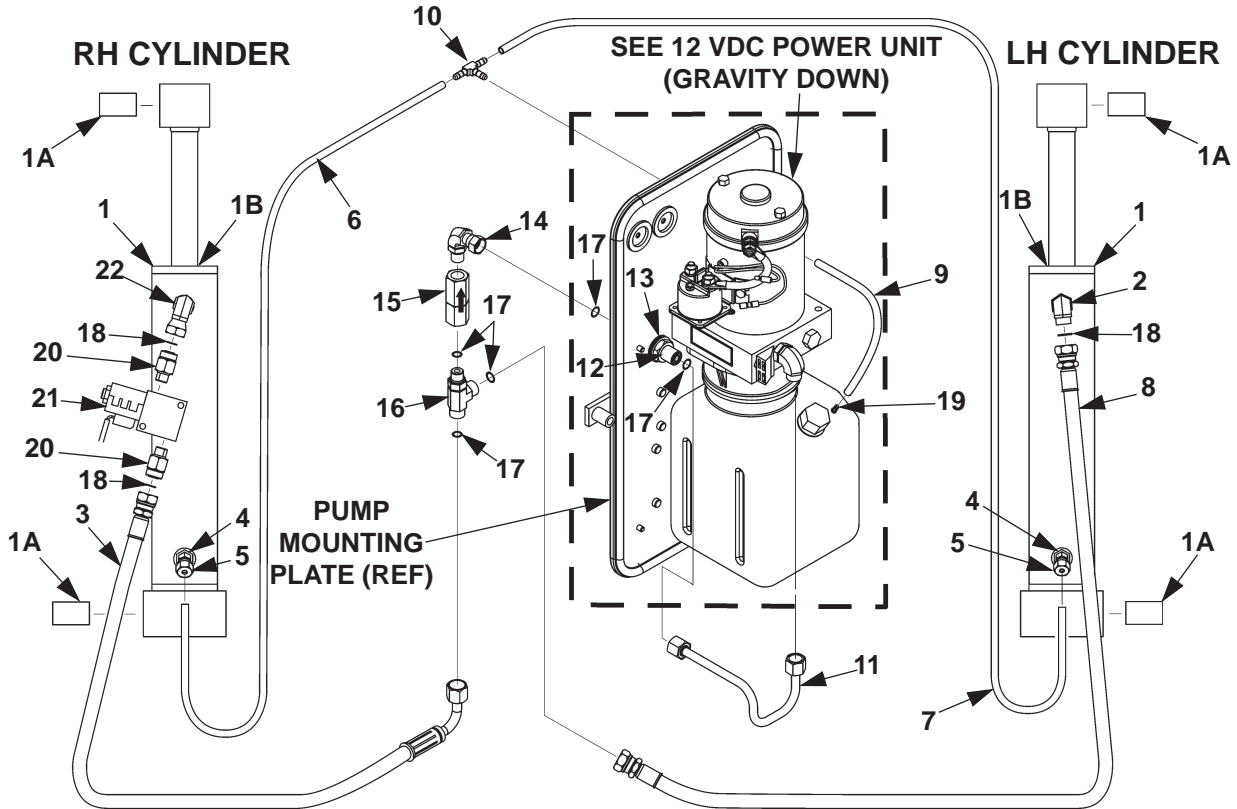

CAUTION

To prevent incorrect operation & damage to liftgate, make sure arrow on flow regulator valve points up as shown in illustration.

MAXON®

11921 Slauson Ave. Santa Fe Springs, CA. 90670 (800) 227-4116 FAX (888) 771-7713

ITEM	QTY.	PART NO.	DESCRIPTION
1	2	280990-01	CYLINDER, 2-3/4" x 11-1/2" STROKE (GPTLR-25/33)
		281035-01	CYLINDER, 3-1/4" X 12-1/2" STROKE (GPTLR-44)
		281040-01	CYLINDER 3-1/2" X 12-1/2" STROKE (GPTLR-55)
1A	2	908046-02	POLYLUBE BEARING (GPTLR-25/33 CYLINDER)
		908047-02	POLYLUBE BEARING (GPTLR-44/55 CYLINDER)
1B	2	280990SK-01	SEAL KIT (GPTLR-25/33 CYLINDER)
		281035SK-01	SEAL KIT (GPTLR-44 CYLINDER)
		281040SK-01	SEAL KIT (GPTLR-55 CYLINDER)
2	1	906704-01	ELBOW, 90° F/S, #8 M-M (WITH O-RING)
3	1	281069-01	HOSE ASSY, 3/8" HP, 43" LG.
4	2	228012	ADAPTER, STRAIGHT THREAD, 9/16"-18 M - 1/4" F
5	2	263811	ELBOW, MALE 45°
6	1	224370-21	HOSE, PLASTIC 38" LG.
7	1	224370-18	HOSE, PLASTIC 95" LG.
8	1	281057-02	HOSE ASSY, 3/8" HP, 121" LG.
9	1	224370-20	HOSE, PLASTIC 9" LG.
10	1	906749-01	UNION TEE
11	1	281067-01	F/S TUBE ASSY
12	1	906744-01	BULKHEAD UNION (WITH O-RING)
13	3	902028-12	FLAT WASHER, 3/4"
14	1	906708-01	ELBOW, 90° F/S, #6 M-M
15	1	906709-04	FLOW REGULATOR VALVE, 4.5 GPM
16	1	906745-01	BRANCH TEE (WITH O-RINGS)
17	5	906712-02	O-RING, #6 (3/8" FACE SEAL TUBE-END)
18	3	906712-03	O-RING, #8 (1/2" FACE SEAL TUBE-END)
19	1	906728-01	DUAL BARBED FITTING
20	2	906762	CONNECTOR, M-M, 9/16"-18 X 3/4" (WITH O-RING)
21	1	281308-01	LOCK VALVE
22	1	906763-01	CONNECTOR, M-M, 9/16"-18 X 13/16"-16 (WITH O-RING)

POWER DOWN HYDRAULIC COMPONENTS

MAXON

11921 Slauson Ave. Santa Fe Springs, CA. 90670 (800) 227-4116 FAX (888) 771-7713

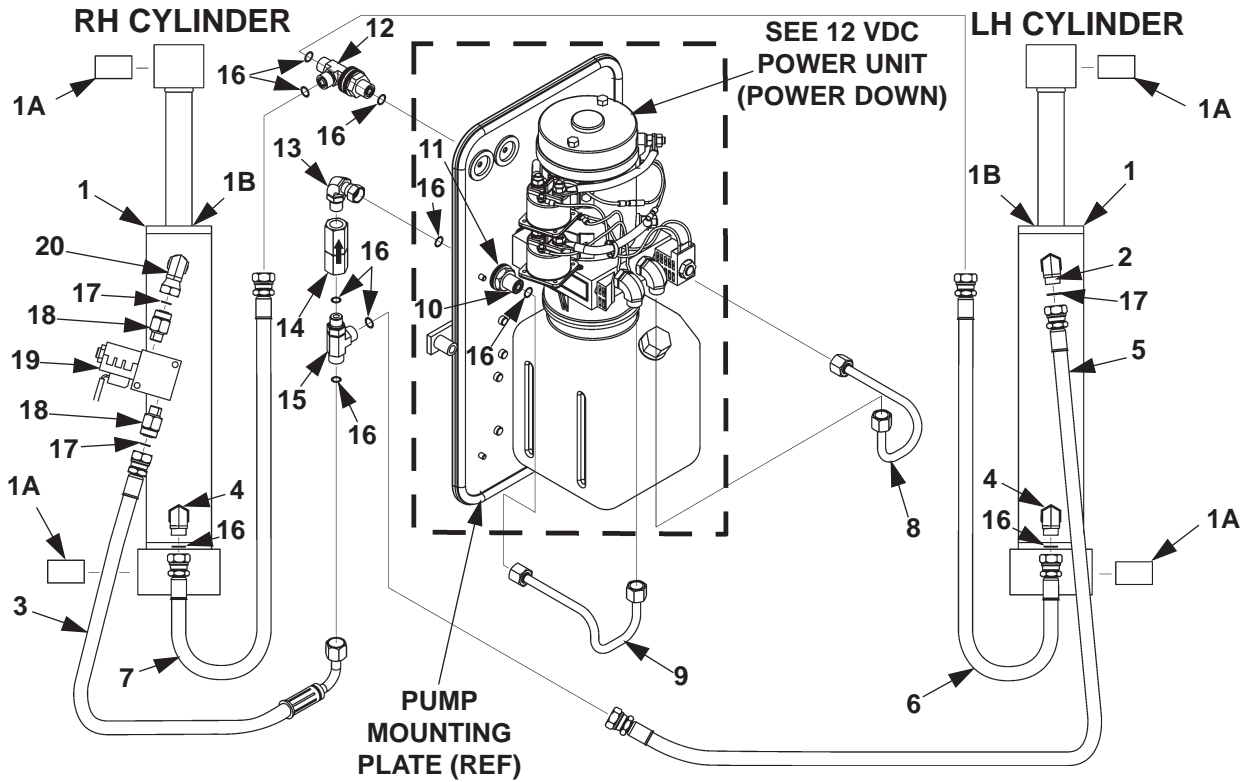

CAUTION

To prevent incorrect operation & damage to liftgate, make sure arrow on flow regulator valve points up as shown in illustration.

ITEM	QTY.	PART NO.	DESCRIPTION
1	2	280990-01	CYLINDER, 2-3/4" x 11-1/2" STROKE (GPTLR-25/33)
		281035-01	CYLINDER, 3-1/4" X 12-1/2" STROKE (GPTLR-44)
		281040-01	CYLINDER, 3-1/2" X 12-1/2" STROKE (GPTLR-55)
1A	2	908046-02	POLYLUBE BEARING (GPTLR-25/33 CYLINDER)
		908047-02	POLYLUBE BEARING (GPTLR-44/55 CYLINDER)
1B	2	280990SK-01	SEAL KIT (GPTLR-25/33 CYLINDER)
		281035SK-01	SEAL KIT (GPTLR-44 CYLINDER)
		281040SK-01	SEAL KIT (GPTLR-55 CYLINDER)
2	1	906704-01	ELBOW, 90° F/S, #8 M-M (WITH O-RING)
3	1	281069-01	HOSE ASSY, 3/8" HP, 43" LG.
4	2	906707-01	ELBOW, 90° F/S, #6 M-M (WITH O-RING)
5	1	281057-02	HOSE ASSY, 3/8" HP, 121" LG.
6	1	281058-02	HOSE ASSY, 3/8" HP, 95" LG.
7	1	281058-01	HOSE ASSY, 3/8" HP, 38" LG.
8	1	281055-01	F/S TUBE ASSY
9	1	281056-01	F/S TUBE ASSY
10	1	906744-01	BULKHEAD UNION (WITH O-RING)
11	9	902028-12	FLAT WASHER, 3/4"
12	1	906748-01	BULKHEAD RUN TEE (WITH O-RINGS)
13	1	906708-01	ELBOW, 90° F/S, #6 M-M (WITH O-RING)
14	1	906709-04	FLOW REGULATOR VALVE, 4.5 GPM
15	1	906745-01	BRANCH TEE (WITH O-RINGS)
16	10	906712-02	O-RING, #6 (3/8" FACE SEAL TUBE-END)
17	3	906712-03	O-RING, #8 (1/2" FACE SEAL TUBE-END)
18	2	906762	CONNECTOR, M-M, 9/16"-18 X 3/4" (WITH O-RING)
19	1	281308-01	HYDRAULIC LOCK
20	1	906763-01	CONNECTOR, M-M, 9/16"-18 X 13/16"-16 (WITH O-RING)

MAXON[®] 11921 Slauson Ave. Santa Fe Springs, CA. 90670 (800) 227-4116 FAX (888) 771-7713

12 VDC POWER UNIT (GRAVITY DOWN)

MAXON[®]

11921 Slauson Ave. Santa Fe Springs, CA. 90670 (800) 227-4116 FAX (888) 771-7713

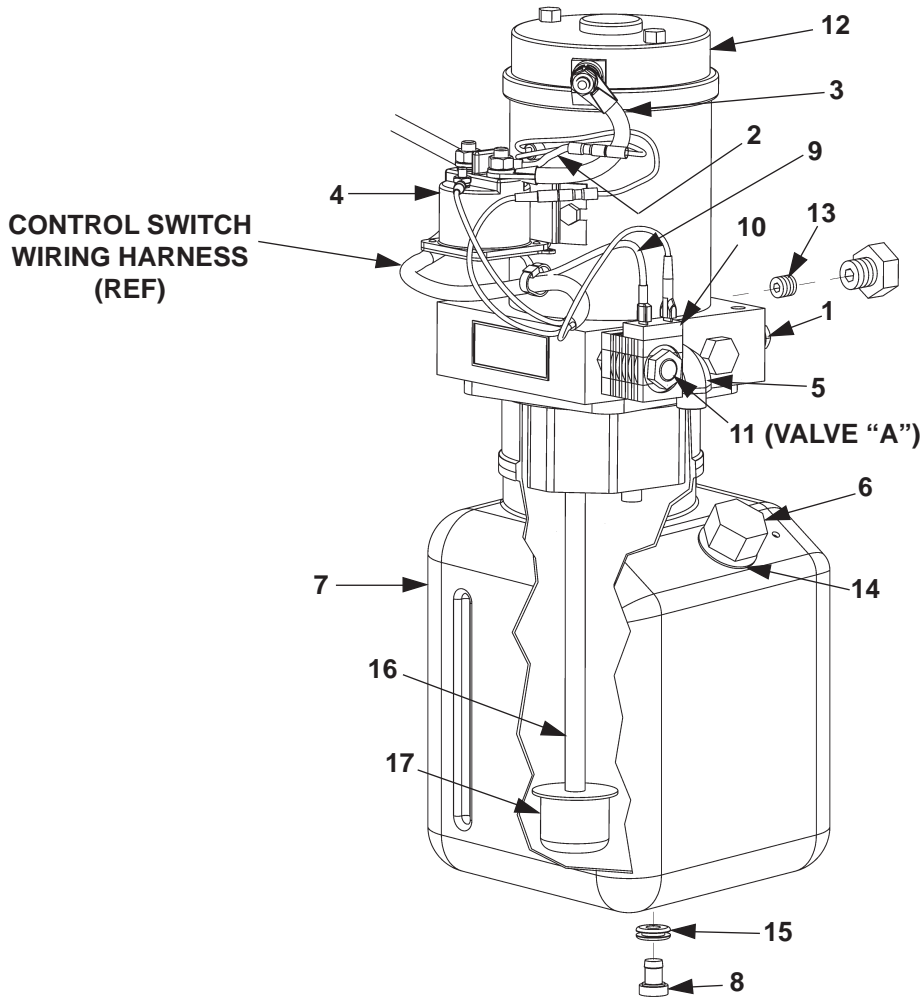

NOTE: MAXON recommends using dielectric grease on all electrical connections.

ITEM	QTY.	PART NO.	DESCRIPTION
	REF	281015-01	12 VDC POWER UNIT (GRAVITY DOWN)
1	1	290002	3 PIECE GEAR PUMP (GRAVITY DOWN)
2	1	280566-01	WIRE ASSEMBLY, 16 GA, GREEN
3	1	280404	CABLE ASSEMBLY
4	1	280394	MOTOR STARTER SOLENOID, 12 VOLTS DC, 3-TERMINAL
5	1	906707	90° ELBOW
6	1	280806-01	FILLER CAP
7	1	281438-01	RESERVOIR, 5 QUARTS (CAPACITY)
8	1	908017-01	DRAIN PLUG
9	1	280416	WIRE ASSEMBLY
10	1	290064	12 VDC COIL
11	1	906719-01	VALVE, N.C. (VALVE "A")
12	1	280374	MOTOR, 12 VOLTS DC, 1-TERMINAL
13	1	906737-01	RELIEF VALVE
14	1	908016-01	GROMMET, 19/32"
15	1	908018-01	GROMMET, 5/16"
16	1	290075	SUCTION TUBE
17	1	290073	SUCTION FILTER

12 VDC POWER UNIT (POWER DOWN)

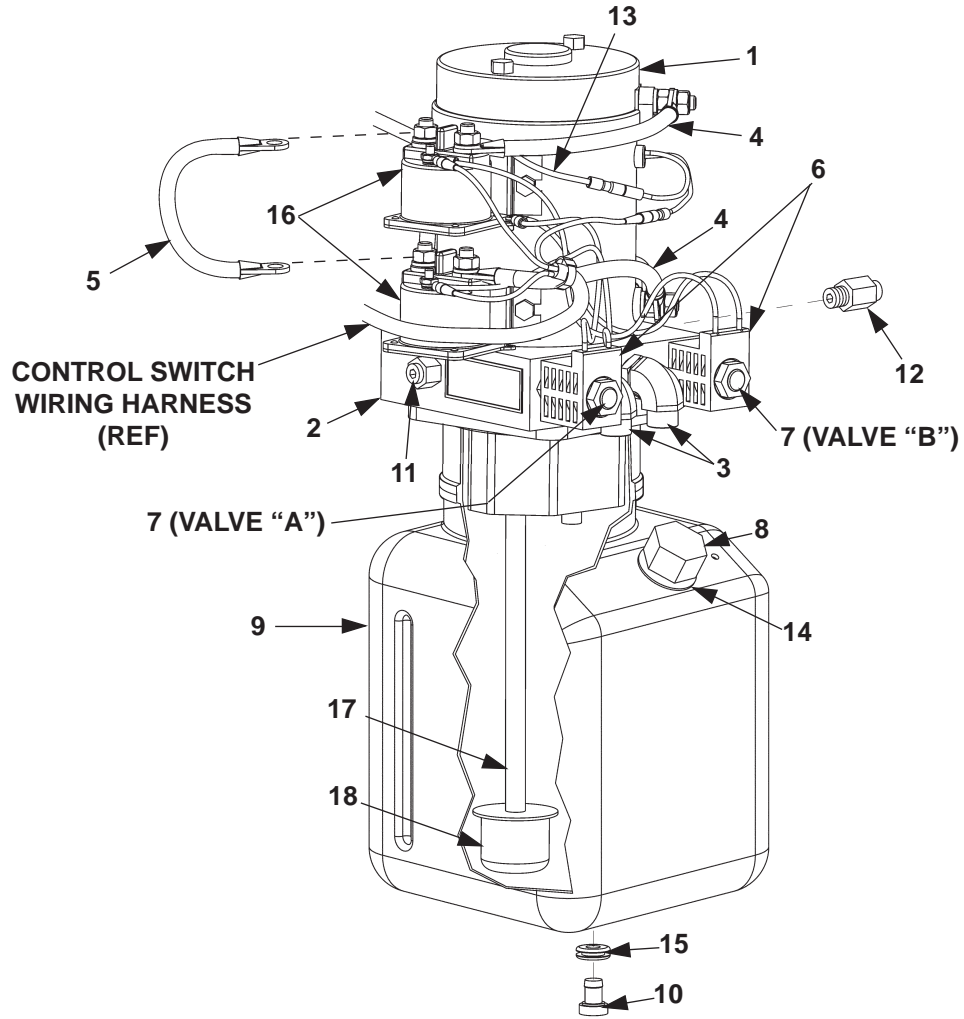

NOTE: MAXON recommends using dielectric grease on all electrical connections.

MAXON[®]

11921 Slauson Ave. Santa Fe Springs, CA. 90670 (800) 227-4116 FAX (888) 771-7713

ITEM	QTY.	PART NO.	DESCRIPTION
	REF	281020-01	12 VDC POWER UNIT (POWER DOWN)
1	1	280381	MOTOR, 12 VOLTS DC, 2-TERMINAL BI-ROT.
2	1	290076	3 PIECE GEAR PUMP, BI-ROTATIONAL (POWER DOWN)
3	2	906707-01	ELBOW, 90°
4	2	280404	CABLE ASSEMBLY
5	1	280543	CABLE ASSEMBLY
6	2	906720-01	10 VDC COIL
7	2	906719-01	VALVE, N.C.
8	1	280806-01	FILLER CAP
9	1	281437-01	RESERVOIR, 5 QUARTS (CAPACITY)
10	1	908017-01	DRAIN PLUG
11	1	906738-02	RELIEF VALVE, HP
12	1	906738-01	RELIEF VALVE, LP
13	1	280566-01	WIRE ASSEMBLY, 16 GA, GREEN
14	1	908016-01	GROMMET, 19/32"
15	1	908018-01	GROMMET, 5/16"
16	2	280394	MOTOR STARTER SOLENOID, 12 VOLTS DC, 3-TERMINAL
17	1	290075	SUCTION TUBE
18	1	290073	SUCTION FILTER

MAXON

11921 Slauson Ave. Santa Fe Springs, CA. 90670 (800) 227-4116 FAX (888) 771-7713

DECALS

OPERATING INSTRUCTIONS	
OPERATE	STOW
<p>1 PUSH CONTROL SWITCH</p> <p>MUST TOUCH GROUND</p>	<p>1 FOLD FLIPOVER. LATCH IF EQUIPPED</p> <p>(SEE CAUTION)</p>
<p>2 UNFOLD PLATFORM</p>	<p>2 FOLD PLATFORM</p>
<p>3 UNFOLD FLIPOVER. UNLATCH IF EQUIPPED</p>	<p>3 PUSH CONTROL SWITCH</p>
<p>4 RAISE/LOWER</p>	<p>4 STOWED</p>

DECAL, P/N 251867-09

**INSTRUCTION DECAL
P/N 251867-09.**

WARNING

NEVER OPERATE LIFTGATE WHEN WALK RAMP IS EXTENDED.

ALWAYS STOW WALK RAMP BEFORE OPERATING LIFTGATE.

DECAL, P/N 265441-01

**WALK RAMP WARNING DECAL (WALK RAMP EQUIPPED VEHICLES ONLY)
P/N 265441-01**

NOTICE

- LOWER LIFTGATE TO GROUND BEFORE YOU SET UP WALK RAMP. REFER TO LIFTGATE OPERATING INSTRUCTIONS DECAL.
- READ WALK RAMP WARNING DECAL BEFORE YOU SET UP WALK RAMP.
- TO SET UP WALK RAMP & STOW WALK RAMP, REFER TO WALK RAMP MANUFACTURER'S INSTRUCTIONS.
- TO STOW LIFTGATE (AFTER WALK RAMP IS STOWED), REFER TO LIFTGATE OPERATING INSTRUCTIONS DECAL.

DECAL, P/N 266013-01

**WALK RAMP NOTICE DECAL (WALK RAMP EQUIPPED VEHICLES ONLY)
P/N 266013-01**

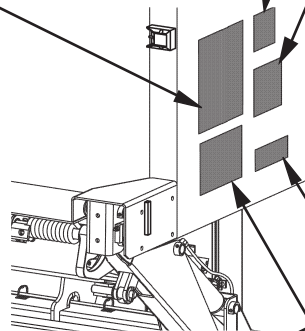

WARNING

READ THIS INFORMATION CAREFULLY

- Improper operation of this Liftgate can result in serious personal injury. Do not operate unless you have been properly instructed and have read, and are familiar with the operating instructions. If you do not have a copy of the instructions, please obtain them from your employer, distributor, or lessor before you attempt to operate Liftgate.
- Be certain that the vehicle is properly and securely braked before using the Liftgate.
- Always inspect this Liftgate for maintenance or damage before using it. If there are signs of improper maintenance, damage to vital parts, or slippery Platform surface, do not use the Liftgate until these problems have been corrected.
- Do not overload the Liftgate. The load limit is based on evenly distributed cargo over the entire Platform surface. If you are using a pallet jack, be sure it can be maneuvered safely. Do not operate a forklift on the Platform or travel with the platform in an open position at any time.
- Load should be placed in a stable position close to the edge of the Platform nearest the truck. The heaviest portion of the load should never be placed beyond the center of the Platform away from the truck.
- Never allow yourself, a helper, or bystander to stand in a position where a falling load could land on either of you. Also do not allow any part of yours or your helper's body to be placed under, within, or around any portion of the moving Liftgate, or its mechanisms, or in a position that would trap them between the platform and the ground or truck when the Liftgate is operated.
- If a helper is riding the Platform with you, make sure you are both doing so safely and that you are not in danger of coming in contact with any moving or potentially moving obstacles. USE GOOD COMMON SENSE. If load appears to be unsafe, do not lift or lower it.

For a free copy of other manuals that pertain to this model Liftgate, please visit our website at www.maxonlift.com or call Customer Service at (800) 227-4116.

MAXON LIFT CORP. PART NO. 264081

**WARNING DECAL
P/N 264081**

THE MAXIMUM CAPACITY OF THIS LIFT IS

POUNDS

WHEN THE LOAD IS CENTERED ON PLATFORM

CAPACITY DECAL (SEE TABLE 64-1)

CAPACITY DECALS	
CAPACITY	PART NO.
2500 LBS.	220382
3300 LBS.	220388-02
4400 LBS.	253155
5500 LBS.	253161

TABLE 64-1

FIG. 64-1



WARNING DECAL
P/N 265736-01

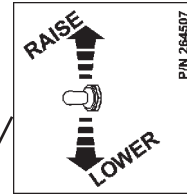

CONTROL SWITCH DECAL
P/N 264507

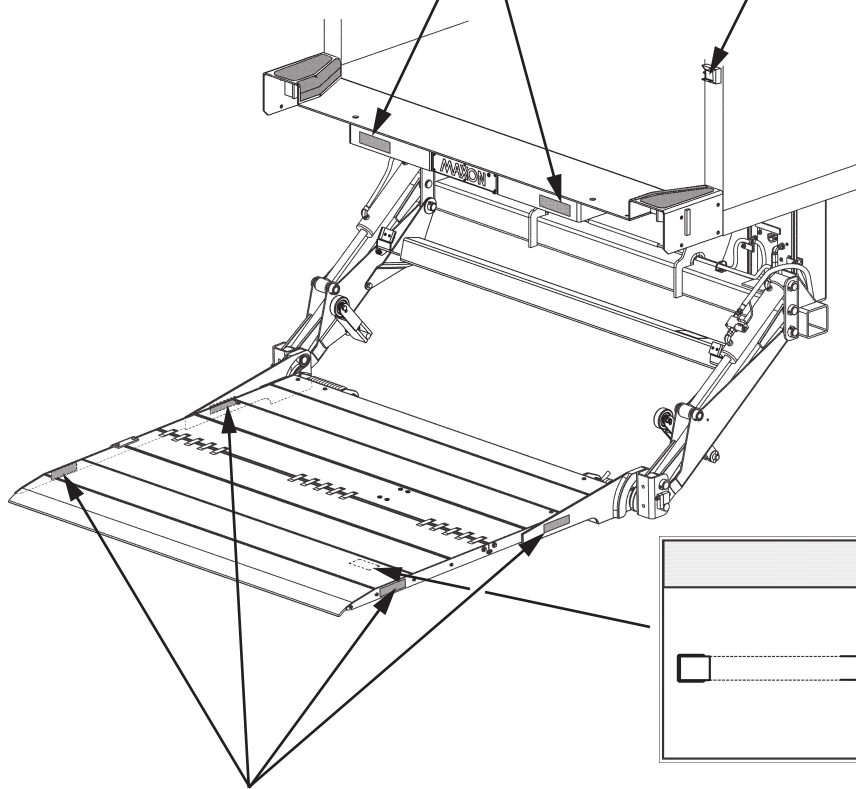

CAUTION DECAL
(FLIPOVER EQUIPPED WITH LATCH, ONLY)
P/N 267694-01



WARNING DECAL
P/N 265736-02

FIG. 65-1

NONSKID & SAFETY STRIPING

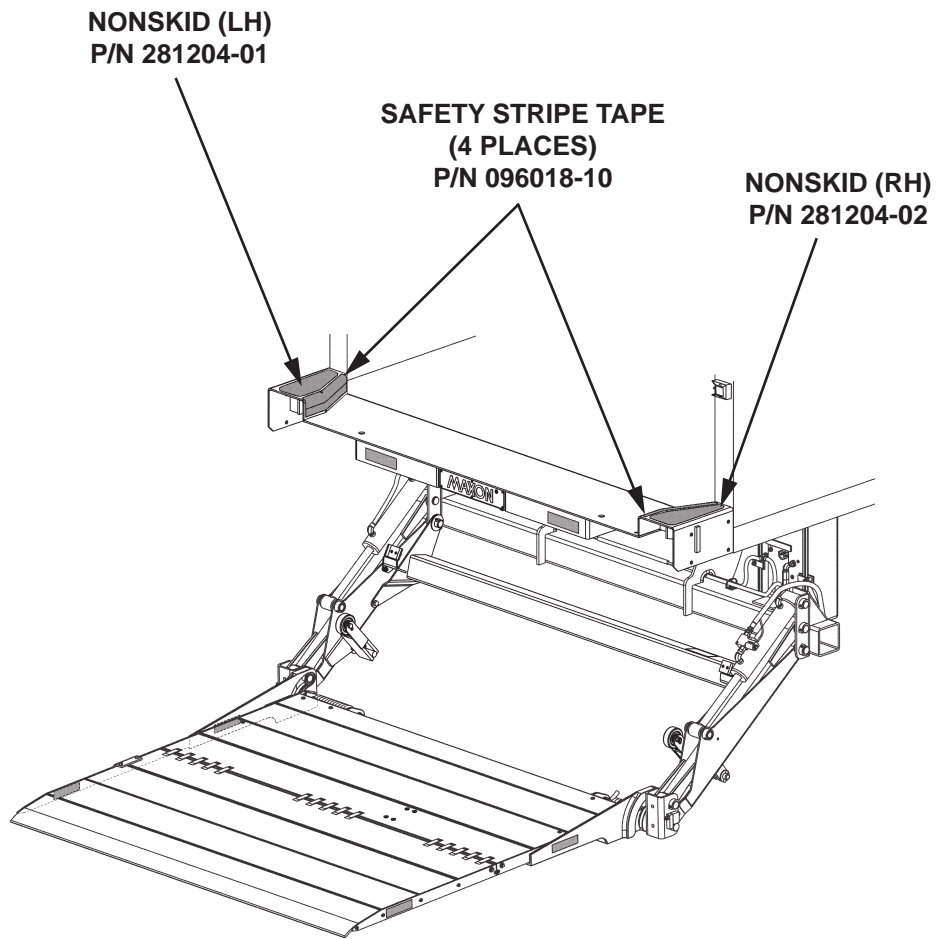

FIG. 66-1

MAXON[®]

11921 Slauson Ave. Santa Fe Springs, CA. 90670 (800) 227-4116 FAX (888) 771-7713

CONTROL SWITCH AND POWER CABLE

NOTE: Use Switch to **RAISE** and **LOWER** Liftgate to make sure Switch operates as shown on the decal.

NOTE: MAXON recommends using dielectric grease on all electrical connections.

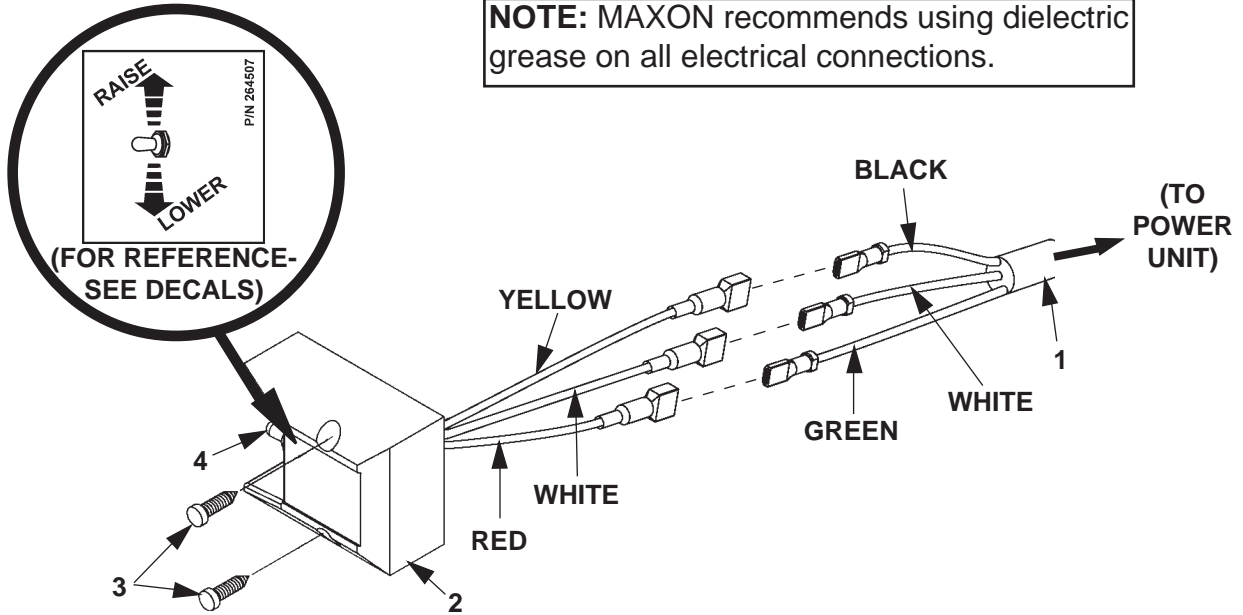
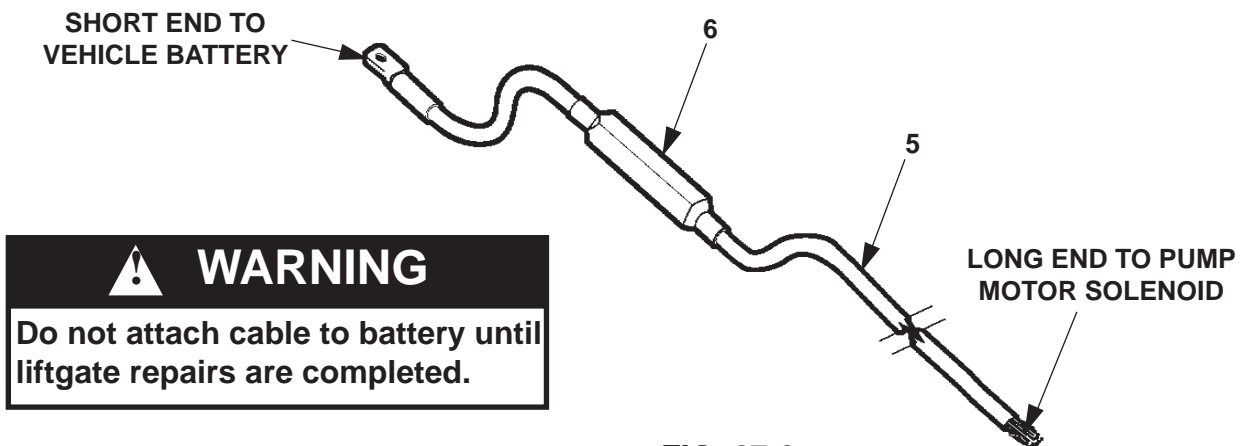

FIG. 67-1

ITEM	QTY.	PART NO.	DESCRIPTION
1	1	280637-01	HARNESS ASSEMBLY, 84" LG. (GRAVITY DOWN)
		280638-01	HARNESS ASSEMBLY, 84" LG. (POWER DOWN)
2	1	264346	SWITCH & CABLE
3	2	900057-5	SCREW, SELF-TAPPING #10-24 X 1" LG.
4	1	905206	SWITCH BOOT SEAL
5	1	264422	CABLE ASSEMBLY, 200 AMPS, 38' LG.
6	1	264687	KIT, MEGAFUSE (200 AMP FUSE & HEATSHRINK TUBING)

TABLE 67-1



⚠ WARNING

Do not attach cable to battery until liftgate repairs are completed.

FIG. 67-2

HYDRAULIC SYSTEM DIAGRAMS

HYDRAULIC SCHEMATIC (GRAVITY DOWN)

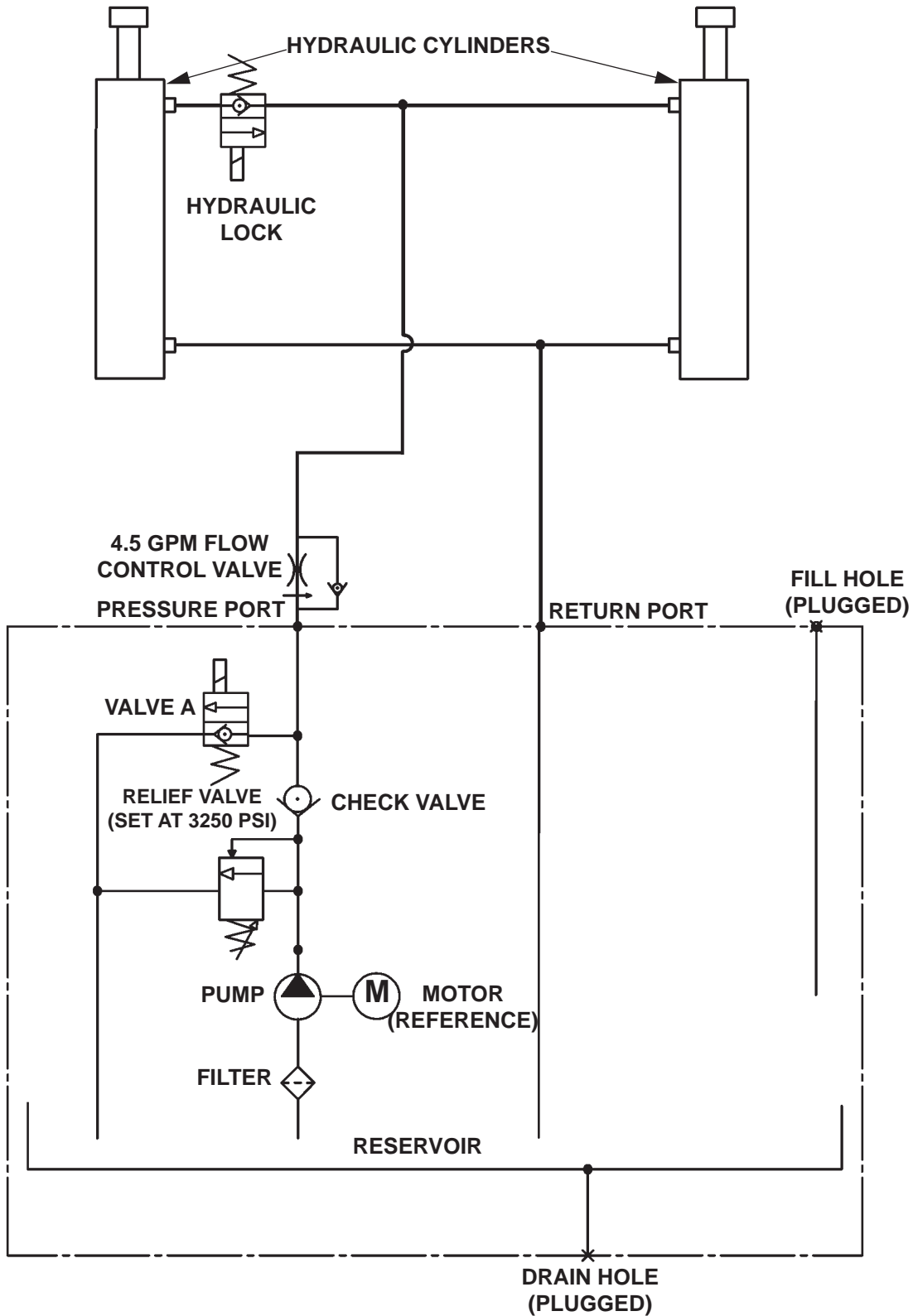

FIG. 68-1

HYDRAULIC SCHEMATIC (POWER DOWN)

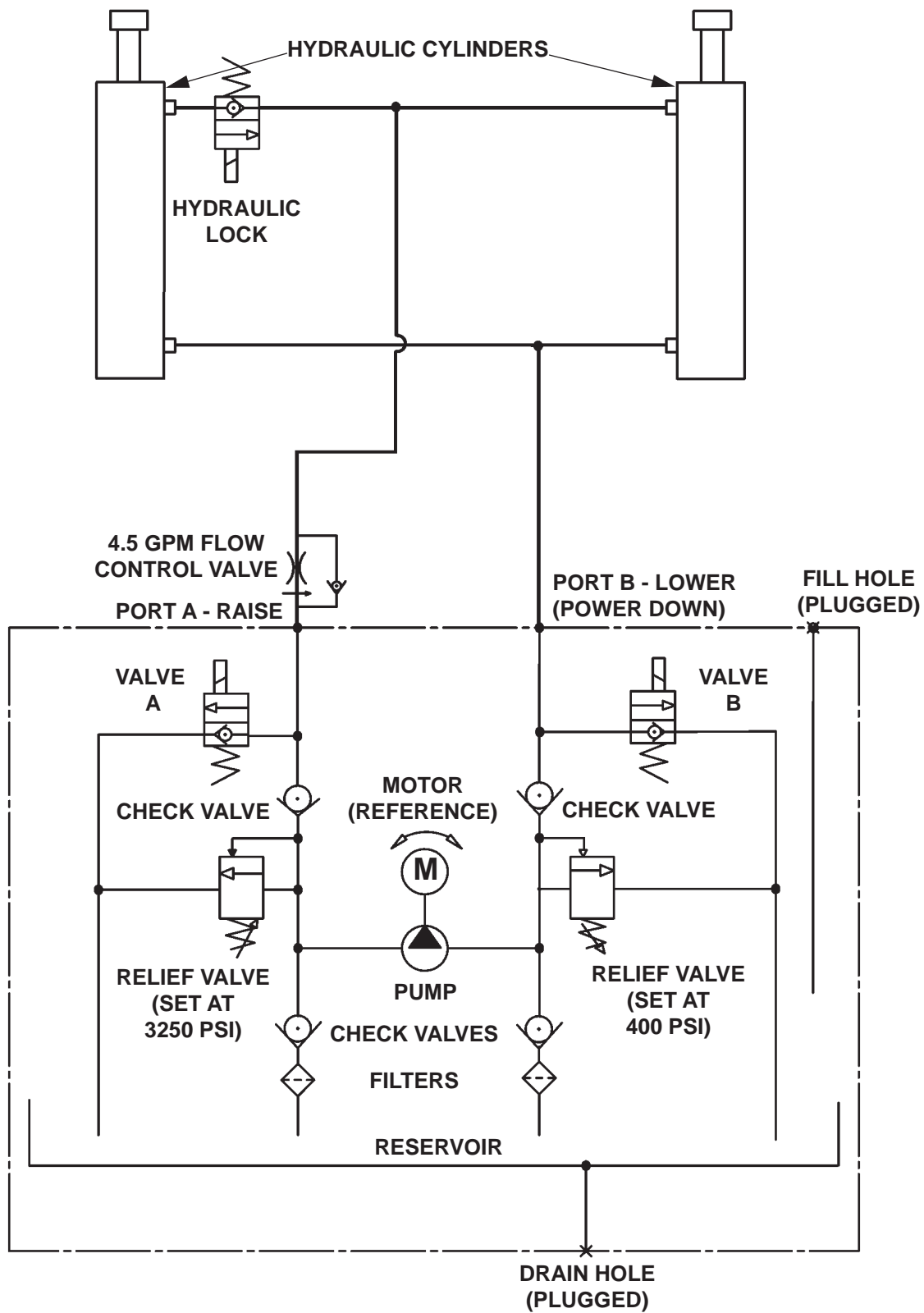

FIG. 69-1

ELECTRICAL SYSTEM DIAGRAMS

ELECTRICAL SCHEMATIC (GRAVITY DOWN)

MAXON[®]

11921 Slauson Ave. Santa Fe Springs, CA. 90670 (800) 227-4116 FAX (888) 771-7713

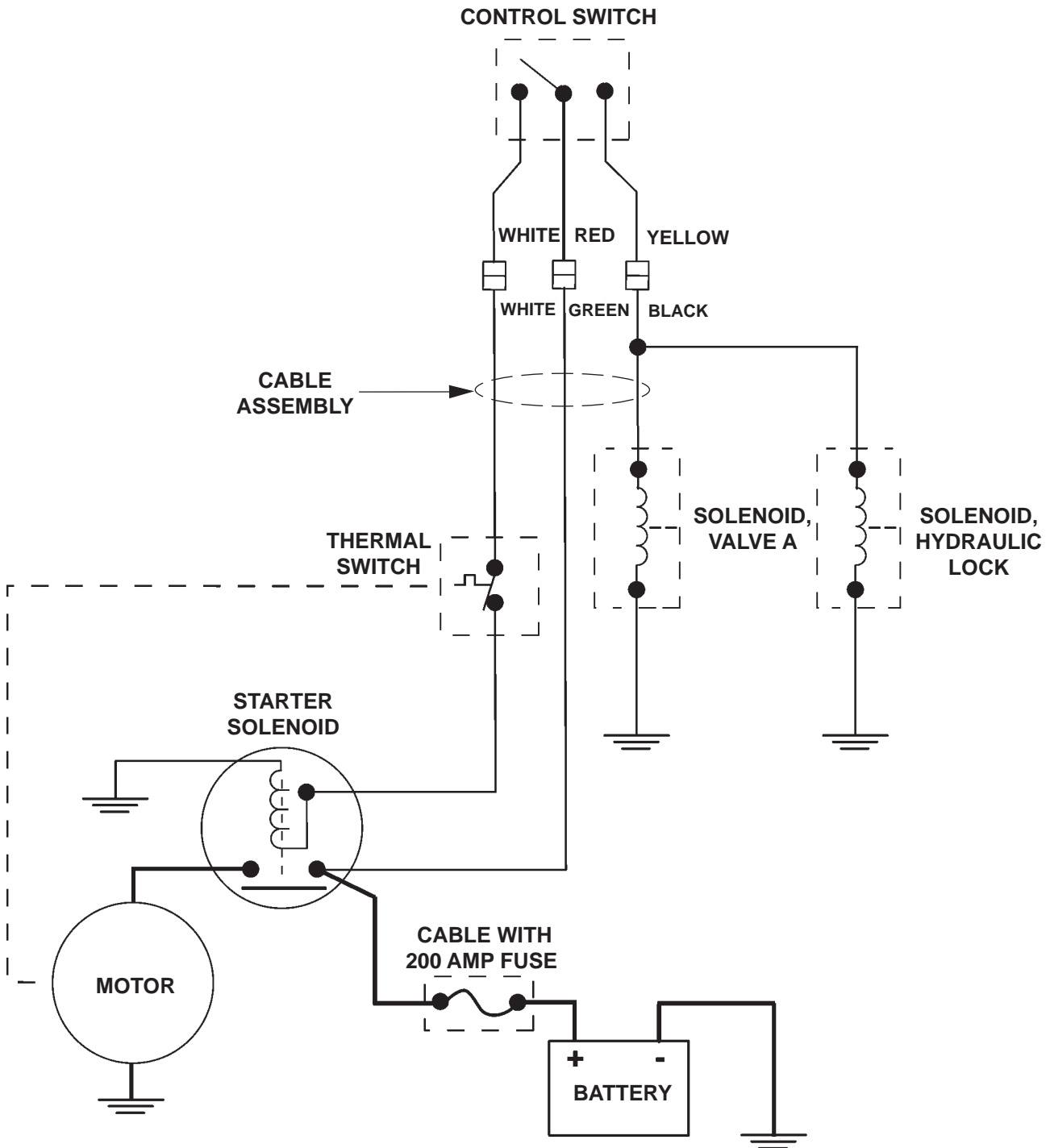

FIG. 70-1

ELECTRICAL SCHEMATIC (POWER DOWN)

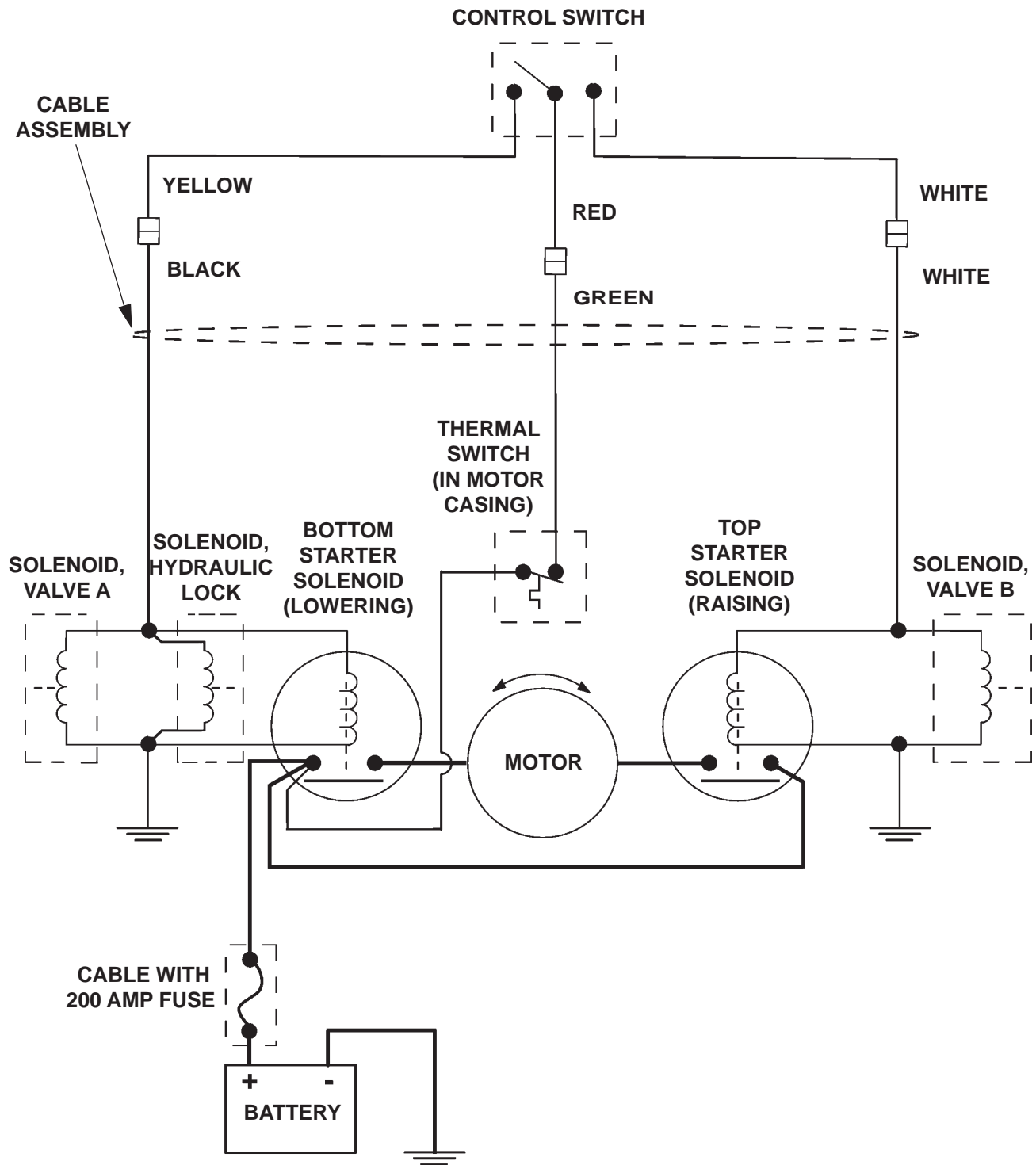

FIG. 71-1

RECOMMENDED BOLT TORQUES

CAUTION

The torque values in the following table are provided for torquing Grade 8 bolts on Liftgate mechanical parts. To prevent damage, never use the information in this table for torquing electrical or hydraulic hose connections on the Pump Assembly.

GRADE 8 BOLT TIGHTENING TORQUE	
DIAMETER & THREAD PITCH	TORQUE
1/4"-20	10-14 LBS.-FT.
1/4"-28	11-16 LBS.-FT.
5/16"-18	20-29 LBS.-FT.
5/16"-24	22-33 LBS.-FT.
3/8"-16	35-52 LBS.-FT.
3/8"-24	40-59 LBS.-FT.
7/16"-14	56-84 LBS.-FT.
7/16"-20	62-93 LBS.-FT.
1/2"-13	85-128 LBS.-FT.
1/2"-20	96-144 LBS.-FT.
9/16"-12	123-184 LBS.-FT.
9/16"-18	137-206 LBS.-FT.
5/8"-11	170-254 LBS.-FT.
5/8"-18	192-288 LBS.-FT.
3/4"-10	301-451 LBS.-FT.
3/4"-18	336-504 LBS.-FT.

TABLE 72-1

MAXON[®]

11921 Slauson Ave. Santa Fe Springs, CA. 90670 (800) 227-4116 FAX (888) 771-7713

TROUBLESHOOTING

PLATFORM WILL NOT RAISE

1. Use voltmeter to verify that power is being supplied to Solenoid Terminal "A" (FIG. 73-1.) Recharge the battery if less than 12.6 volts.

CAUTION

Keep dirt, water and other contaminants from entering the hydraulic system. Before opening the hydraulic fluid reservoir filler cap, drain plug and hydraulic lines, clean up contaminants that can get in the openings. Also, protect the openings from accidental contamination during maintenance.

2. Fill Reservoir to within 1/2" below the top with the hydraulic fluid recommended in the Periodic Maintenance Checklist.
3. Touch a jumper wire to terminals "B" & "C" (FIG. 73-1). If motor runs check Switch, switch connections, and White wire. Check and correct wiring connections or replace the Switch.
4. Touch heavy jumper cables to terminals "A" & "B" (FIG. 73-1).
 - a. If motor runs, replace the motor solenoid.
 - b. If motor does not run, repair or replace the pump motor.

NOTE: In most cases, you can avoid having to bleed the hydraulic system by correctly positioning Liftgate Platform before opening hydraulic lines. Refer to following procedure. Save time on the job and prevent accidental fluid spills and hazards.

5. Check for structural damage and replace worn parts.
6. Check filter in the pump Reservoir. Replace filter if necessary.
7. Check for dirty pump motor relief valve. Clean if necessary. Replace any worn out relief valve parts.

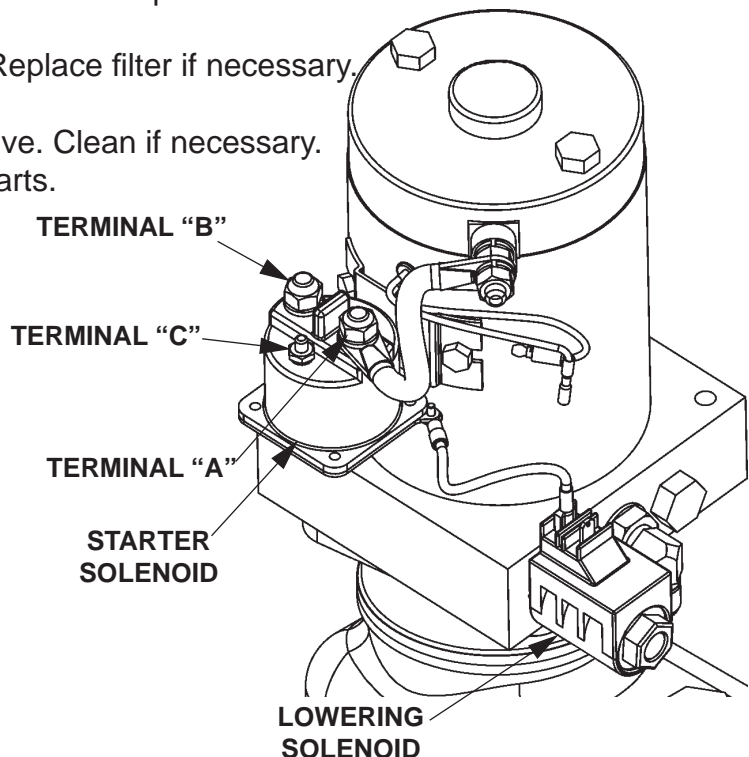

FIG. 73-1

TROUBLESHOOTING

PLATFORM RAISES BUT LEAKS DOWN

1. Check if Solenoid Valves are constantly energized by touching a screwdriver to the top nut of the Solenoid (**FIG. 74-1**). Try pulling the screwdriver away from the solenoid. If the solenoid nut attracts the screwdriver (magnetically) without pushing the toggle switch, the control circuit is operating incorrectly. Check if toggle switch, wiring or coil are faulty.

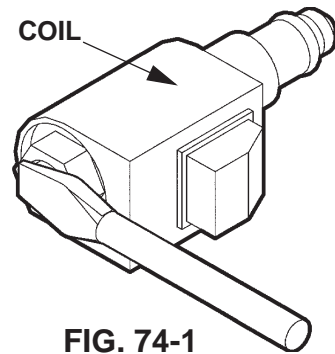

FIG. 74-1

CAUTION

Keep dirt, water and other contaminants from entering the hydraulic system. Before opening the hydraulic fluid reservoir filler cap, drain plug and hydraulic lines, clean up contaminants that can get in the openings. Also, protect the openings from accidental contamination during maintenance.

NOTE: In most cases, you can avoid having to manually bleed Hydraulic System by correctly positioning Liftgate Platform before disconnecting any Lifting Cylinder high pressure Hydraulic Lines. The following procedure can save time and prevent accidental fluid spills and hazards.

2. Check the Valve Stem by removing the Coil Assembly (**Item 1, FIG. 74-2**). With platform on ground, unscrew the Valve Stem, (**Item 2, FIG. 74-2**) from the Pump. Push on the plunger that is located inside the Valve Stem by inserting a small screwdriver blade in the end. If the Plunger does not move freely (approximately 1/8") replace the Valve Stem. **When re-installing valve stem, torque hex nut to 30 in-lbs.**
3. Check the Hydraulic Cylinder. With the Platform on the ground, remove the hydraulic line from the Down Port of the Cylinder (**FIG. 74-3**). Raise the Platform even with the bed. Allow pump motor to run two seconds more while you watch for hydraulic fluid at the Down Port. A few drops of hydraulic fluid escaping the Down Port is normal; however, if it streams from the Down Port, Piston Seals are worn. Replace Seals.

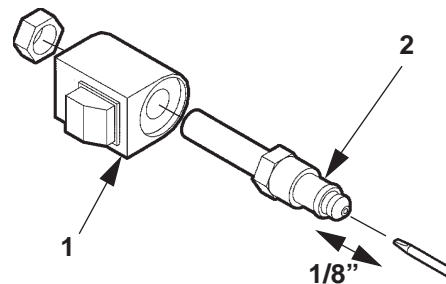

FIG. 74-2

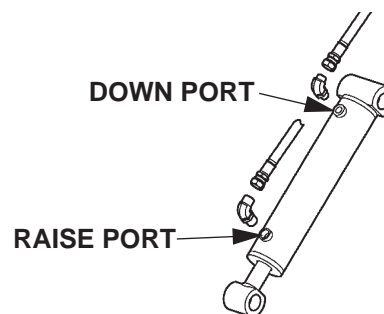

FIG. 74-3

PLATFORM RAISES PARTIALLY AND STOPS

CAUTION

Keep dirt, water and other contaminants from entering the hydraulic system. Before opening the hydraulic fluid reservoir filler cap, drain plug and hydraulic lines, clean up contaminants that can get in the openings. Also, protect the openings from accidental contamination during maintenance.

1. Lower the opened Platform to the ground. Fill the Pump Reservoir on Gravity-Down Liftgates to within 1/2" below the top with hydraulic fluid recommended in Periodic Maintenance Checklist.
2. Use voltmeter to verify that the Battery shows 12.6 volts or more.
3. Check for Structural damage, or poor lubrication. Replace worn parts.

NOTE: In most cases, you can avoid having to bleed the hydraulic system by correctly positioning Liftgate Platform before opening hydraulic lines. Refer to following procedure. Save time on the job and prevent accidental fluid spills and hazards.

4. Check the Hydraulic Cylinder. With the Platform on the ground, remove the Breather Plug or Vent Line from the Vent Port of the Cylinder (**FIG. 75-1**). Raise the Platform even with the bed. Allow pump motor to run two seconds more while you watch for hydraulic fluid at the Vent Port. A few drops of hydraulic fluid escaping the Vent Port is normal; however, if it streams from the Vent Port, Piston Seals are worn. Replace Seals.

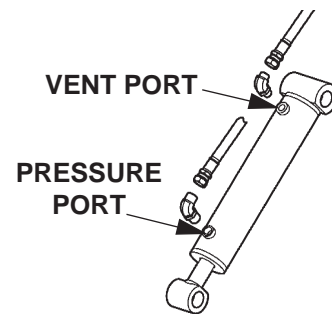

FIG. 75-1

5. Check Filter in the Pump Reservoir. Replace filter if necessary.
6. Check for dirty pump motor relief valve. Clean if necessary. Replace any worn out relief valve parts.

TROUBLESHOOTING

LIFTGATE WILL NOT LIFT RATED CAPACITY

1. Use voltmeter to verify that the Battery shows 12.6 volts or more under load from pump motor.
2. Check for Structural damage or lack of lubrication. Replace worn parts.

CAUTION

Keep dirt, water and other contaminants from entering the hydraulic system. Before opening the hydraulic fluid reservoir filler cap, drain plug and hydraulic lines, clean up contaminants that can get in the openings. Also, protect the openings from accidental contamination during maintenance.

NOTE: In most cases, you can avoid having to bleed the hydraulic system by correctly positioning Liftgate Platform before opening hydraulic lines. Refer to following procedure. Save time on the job and prevent accidental fluid spills and hazards.

3. With Platform on the ground, remove the pressure hose and fitting from the Pump and replace it with a 0-3000 PSI Pressure Gauge. Hold the switch in the "UP" position. Adjust the Relief Valve on the side of the Pump until the gauge shows 2800 to 3000 PSI (**FIG. 76-2**). Remove gauge and re-install pressure hose.
4. Check for dirty pump motor relief valve. Clean if necessary. Replace any worn out relief valve parts.
5. Check the Hydraulic Cylinder. With the Platform on the ground, remove the Breather Plug or Vent Line from the Vent Port of the Cylinder (**FIG. 76-1**). Raise the Platform even with the bed. Allow pump motor to run two seconds more while you watch for hydraulic fluid at the Vent Port. A few drops of hydraulic fluid escaping the Vent Port is normal; however, if it streams from the Vent Port, Piston Seals are worn. Replace Seals.
6. If Pump cannot produce 2800-3000 PSI with a minimum of 12.6 Volts available, the Pump is worn and needs to be replaced.

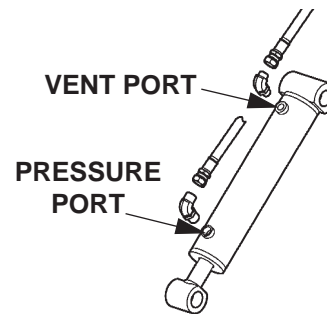

FIG. 76-1

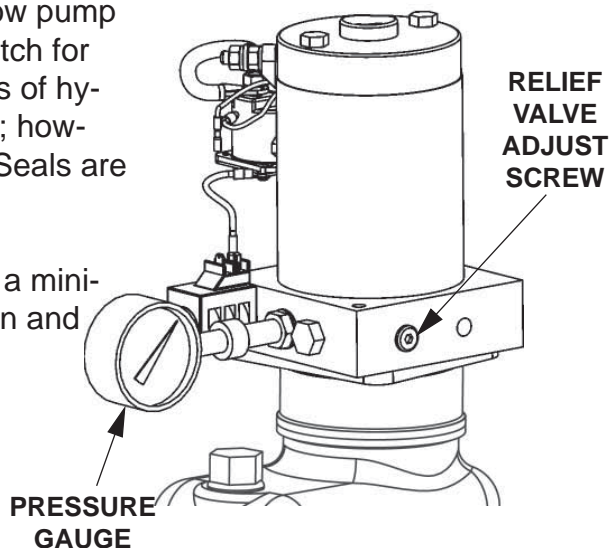

FIG. 76-2

PLATFORM RAISES SLOWLY

1. Use voltmeter to verify that power is being supplied to Solenoid Terminal "B". Recharge the battery if voltmeter indicates less than 12.6 Volts (FIG. 77-1).

CAUTION

Keep dirt, water and other contaminants from entering the hydraulic system. Before opening the hydraulic fluid reservoir filler cap, drain plug and hydraulic lines, clean up contaminants that can get in the openings. Also, protect the openings from accidental contamination during maintenance.

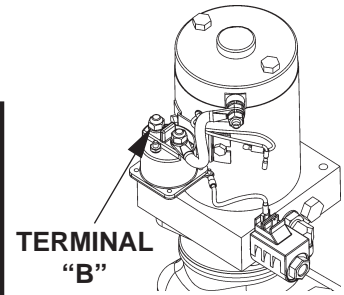

FIG. 77-1

2. Check the Hydraulic Cylinder. With the Platform on the ground, remove the Breather Plug or Vent Line from the Vent Port of the Cylinder (FIG. 77-3). Raise the Platform even with the bed. Allow pump motor to run two seconds more while you watch for hydraulic fluid at the Vent Port. A few drops of hydraulic fluid escaping the Vent Port is normal; however, if it streams from the Vent Port, Piston Seals are worn. Replace Seals.

NOTE: In most cases, you can avoid having to bleed the hydraulic system by correctly positioning Liftgate Platform before opening hydraulic lines. Refer to following procedure. Save time on the job and prevent accidental fluid spills and hazards.

3. Check and clean Flow Control Valve in high pressure hydraulic line attached to Pump Mounting Plate. When installing Flow Control Valve, make sure it is pointing to the direction of restricted fluid flow (pointing up and back toward pump) (FIG. 77-3).
4. Lower the opened Platform to the ground. Fill the Pump Reservoir on Gravity-Down Liftgates to within 1/2" below the top with hydraulic fluid recommended in Periodic Maintenance Checklist.
5. Verify the Pump Motor is grounded to vehicle frame. Make sure external tooth lock washer is installed under Pump mounting screw and flat washer (FIG. 77-3).

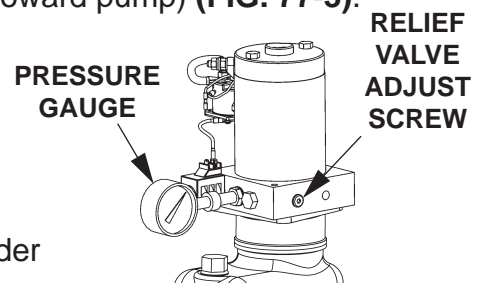

FIG. 77-2

6. Check for leaking hoses and fittings. Tighten or replace as required.
7. Check for structural damage or poor lubrication. Replace worn parts.
8. Check the Filter in the Pump Reservoir. Replace if necessary.
9. With Platform on the ground, remove the pressure hose and fitting from Pump and replace it with a 0-3000 PSI Pressure Gauge. Hold the Control Switch in the "RAISE" position. Adjust the Relief Valve on the side of the Pump until the gauge shows 2800 to 3000 PSI (FIG. 77-2). Remove gauge and reinstall pressure hose.

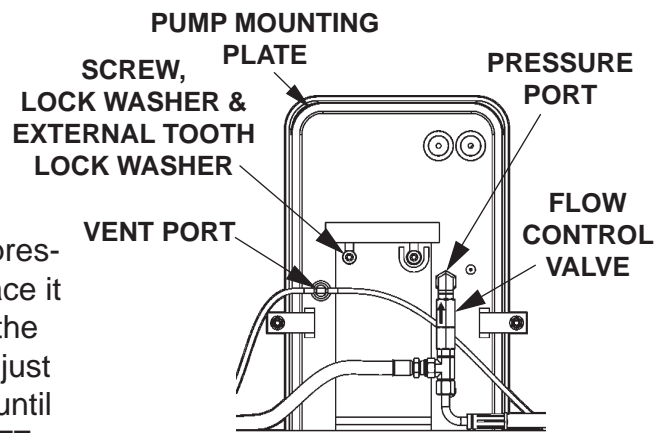

FIG. 77-3

TROUBLESHOOTING

PLATFORM WILL NOT LOWER, LOWERS TOO SLOWLY, OR LOWERS TOO QUICKLY

1. Use voltmeter to verify that power is being supplied to Solenoid Terminal "B". Recharge the battery if voltmeter indicates less than 12.6 Volts (**FIG. 78-1**).
2. Check for structural damage or poor lubrication. Replace worn parts.
3. Check if Solenoid Valve is getting power by holding a screwdriver against the top nut of the Solenoid. Push Control Switch to "**LOWER**" position to energize solenoid (**FIG. 78-2**). A good solenoid will attract (magnetically) the screwdriver to the nut and make it difficult to pull the screwdriver away from the nut.

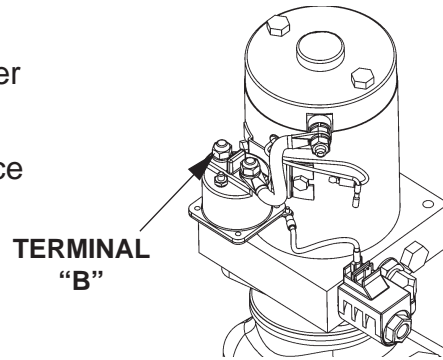

FIG. 78-1

CAUTION

Keep dirt, water and other contaminants from entering the hydraulic system. Before opening the hydraulic fluid reservoir filler cap, drain plug and hydraulic lines, clean up contaminants that can get in the openings. Also, protect the openings from accidental contamination during maintenance.

NOTE: In most cases, you can avoid having to bleed the hydraulic system by correctly positioning Liftgate Platform before opening hydraulic lines. Refer to following procedure. Save time on the job and prevent accidental fluid spills and hazards.

4. Check the Valve Stem by removing the Coil Assembly (**Item 1, FIG. 78-2**). With platform supported, unscrew the Valve Stem (**Item 2, FIG. 78-2**) from the Pump. Push on the plunger located inside the Valve Stem by inserting a small screwdriver blade in the end. If the Plunger does not move freely (approximately 1/8") replace the Valve Stem.
5. Check if filtering screen on solenoid valve is plugged. Clean carefully if required.
6. Check and clean Flow Control Valve in high pressure hydraulic line attached to Pump.
7. Check if Flow Control Valve (**FIG. 78-3**) is pointing to the direction of restricted fluid flow (pointing up and back toward pump). If required, remove Flow Control Valve and install it correctly (**FIG. 78-3**).

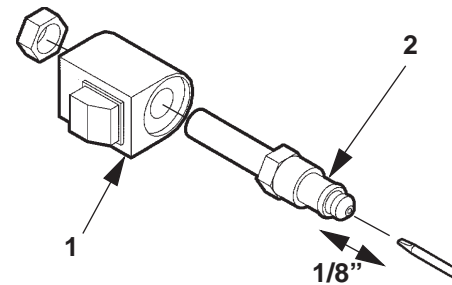

FIG. 78-2

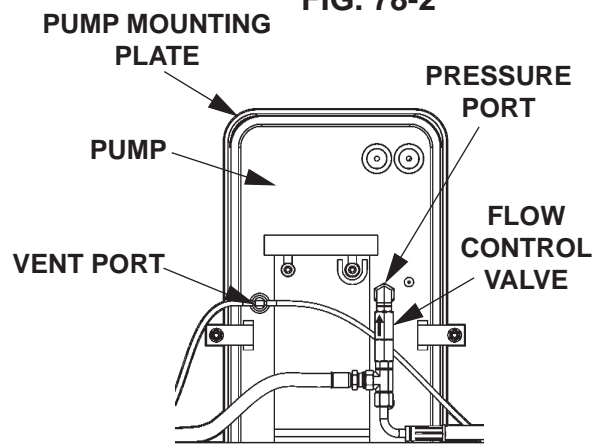

FIG. 78-3

