

M-04-04  
REV. D  
APRIL 2008

# MAXON<sup>®</sup>

## MAINTENANCE MANUAL

GPTLR-25, GPTLR-33, GPTLR-44, & GPTLR-55

**TUK-A-WAY<sup>®</sup>**  
LIFT GATE SERIES

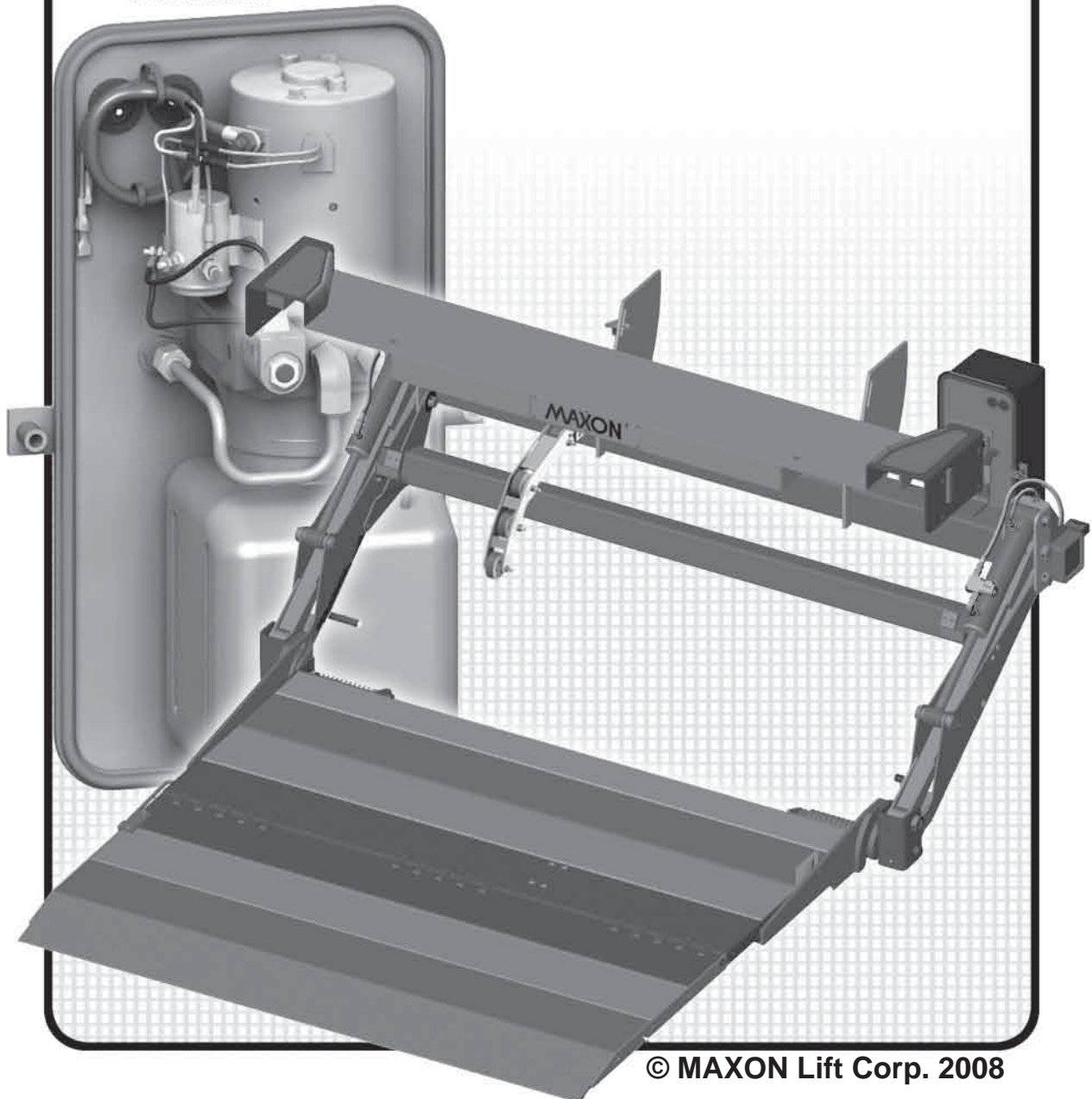

© MAXON Lift Corp. 2008



# MAXON<sup>®</sup>

## LIFT CORP.

11921 Slauson Ave.  
Santa Fe Springs, CA. 90670

### CUSTOMER SERVICE:

TELEPHONE (562) 464-0099 TOLL FREE (800) 227-4116

FAX: (888) 771-7713

NOTE: For latest version of all Manuals (and replacements), download the Manuals from Maxon's website at [www.maxonlift.com](http://www.maxonlift.com).

## WARRANTY/ RMA POLICY & PROCEDURE

### LIFTGATE WARRANTY

Type of Warranty: Full Parts and Labor

Term of Warranty: Standard Liftgates - 2 years from ship date or 6,000 cycles  
Premium Liftgates - 2 years from ship date or 10,000 cycles

This warranty shall not apply unless the product is installed, operated and maintained in accordance with MAXON Lift's specifications as set forth in MAXON Lift's Installation, Operation and Maintenance manuals. This warranty does not cover normal wear, maintenance or adjustments, damage or malfunction caused by improper handling, installation, abuse, misuse, negligence, or carelessness of operation. In addition, this warranty does not cover equipment that has had unauthorized modifications or alterations made to the product.

MAXON agrees to replace any components which are found to be defective during the first 2 years of service, and will reimburse for labor based on MAXON's Liftgate Warranty Flat Rate Schedule. (Copy of the Flat Rate is available at [www.maxonlift.com](http://www.maxonlift.com).)

All warranty repairs must be performed by an authorized MAXON warranty facility. For any repairs that may exceed \$500, including parts and labor, MAXON's Technical Service Department must be notified and an "Authorization Number" obtained.

All claims for warranty must be received within 30 Days of the repair date, and include the following information:

1. Liftgate Model Number and Serial Number
2. The End User must be referenced on the claim
3. Detailed Description of Problem
4. Corrective Action Taken, and Date of Repair
5. Parts used for Repair, Including MAXON Part Number(s)
6. MAXON R.M.A. # and/or Authorization # if applicable (see below)
7. Person contacted at MAXON if applicable
8. Claim must show detailed information i.e. Labor rate and hours of work performed

Warranty claims can also be placed online at [www.maxonlift.com](http://www.maxonlift.com). Online claims will be given priority processing.

All claims for warranty will be denied if paperwork has not been received or claim submitted via Maxon website for processing by MAXON's Warranty Department within 30 days of repair date.

All components may be subject to return for inspection, prior to the claim being processed. MAXON products may not be returned without prior written approval from MAXON's Technical Service Department. Returns must be accompanied by a copy of the original invoice or reference with original invoice number and are subject to a credit deduction to cover handling charges and any necessary reconditioning costs. **Unauthorized returns will be refused and will become the responsibility of the returnee.**

Any goods being returned to MAXON Lift must be pre-approved for return, and have the R.M.A. number written on the outside of the package in plain view, and returned freight prepaid. All returns are subject to a 15% handling charge if not accompanied by a detailed packing list. Returned parts are subject to no credit and returned back to the customer. Defective parts requested for return must be returned within 30 days of the claim date for consideration to:

MAXON Lift Corp.  
10321 Greenleaf Ave., Santa Fe Springs, CA 90670  
Attn: RMA# \_\_\_\_\_

MAXON's warranty policy does not include the reimbursement for travel time, towing, vehicle rental, service calls, oil, batteries or loss of income due to downtime. Fabrication or use of non Maxon parts, which are available from MAXON, are also not covered.

MAXON's Flat Rate Labor Schedule takes into consideration the time required for diagnosis of a problem.

All Liftgates returned are subject to inspection and a 15% restocking fee. Any returned Liftgates or components that have been installed or not returned in new condition will be subject to an additional reworking charge, which will be based upon the labor and material cost required to return the Liftgate or component to new condition.

### PURCHASE PART WARRANTY

Term of Warranty: 1 Year from Date of Purchase.

Type of Warranty: Part replacement only. MAXON will guarantee all returned genuine MAXON replacement parts upon receipt and inspection of parts and original invoice.

All warranty replacements parts will be sent out via ground freight. If a rush shipment is requested, all freight charges will be billed to the requesting party.

# TABLE OF CONTENTS

<b>WARNINGS</b> .....	<b>7</b>
<b>LIFTGATE TERMINOLOGY</b> .....	<b>10</b>
<b>PERIODIC MAINTENANCE</b> .....	<b>11</b>
PERIODIC MAINTENANCE CHECKS .....	11
PERIODIC MAINTENANCE CHECKLIST .....	14
CHECKING HYDRAULIC FLUID .....	16
CHANGING HYDRAULIC FLUID .....	18
PLATFORM TORSION SPRING ADJUSTMENT .....	21
REPLACING PLATFORM TORSION SPRING .....	24
<b>PARTS BREAKDOWN</b> .....	<b>26</b>
MAIN ASSEMBLY: GPTLR-25 & GPTLR-33 (ALUMINUM PLATFORM) .....	26
MAIN ASSEMBLY: GPTLR-44 & GPTLR-55 (ALUMINUM PLATFORM) .....	30
MAIN ASSEMBLY: GPTLR-25 & GPTLR-33 (STEEL PLATFORM & RAMP OPTION) .....	34
MAIN FRAME, LIFTING ARMS, & PARALLEL ARMS: GPTLR-25 & GPTLR-33.....	38
MAIN FRAME, LIFTING ARMS, & PARALLEL ARMS: GPTLR-44 & GPTLR-55.....	42
OPENER (GPTLR-25 & GPTLR-33) .....	46
OPENER (GPTLR-44 & GPTLR-55) .....	47
LH & RH PLATFORM SEATS: GPTLR-25 & GPTLR-33 (ALUMINUM PLATFORM WITH FIXED RAMP OR CART STOPS ONLY).....	48
LH & RH PLATFORM SEATS: GPTLR-25 & GPTLR-33 (ALUMINUM PLATFORM WITH RETENTION RAMP ONLY).....	49
LH & RH PLATFORM SEATS: GPTLR-25 & GPTLR-33 (STEEL PLATFORM ONLY) .....	50
LH & RH PLATFORM SEATS: GPTLR-44 & GPTLR-55 (ONLY ALUMINUM PLATFORM WITH FIXED RAMP OR CART STOPS) .....	51

LH & RH PLATFORM SEATS: GPTLR-44 & GPTLR-55 (ONLY PLATFORM WITH RETENTION RAMP) .....	52
PLATFORM & FLIPOVER ASSEMBLY (ALUMINUM).....	54
PLATFORM & FLIPOVER ASSEMBLY WITH CART STOPS (ALUMINUM).....	56
FLIPOVER WITH SINGLE CART STOP (ALUMINUM) .....	58
FLIPOVER WITH DUAL CART STOPS (ALUMINUM).....	60
PLATFORM & FLIPOVER ASSEMBLY WITH SINGLE RETENTION RAMP (ALUMINUM).....	62
FLIPOVER WITH SINGLE RETENTION RAMP (ALUMINUM).....	64
PLATFORM & FLIPOVER ASSEMBLY (STEEL) .....	66
PUMP COVER & MOUNTING PLATE ASSEMBLY (GRAVITY DOWN) .....	68
PUMP COVER & MOUNTING PLATE ASSEMBLY (POWER DOWN).....	69
GRAVITY DOWN HYDRAULIC COMPONENTS .....	70
POWER DOWN HYDRAULIC COMPONENTS .....	72
12 VDC POWER UNIT (GRAVITY DOWN).....	74
12 VDC POWER UNIT (POWER DOWN).....	76
DECALS .....	78
NONSKID & SAFETY STRIPING.....	80
CONTROL SWITCH AND POWER CABLE .....	81
<b>SYSTEM DIAGRAMS .....</b>	<b>82</b>
PUMP & MOTOR SOLENOID OPERATION (GRAVITY DOWN).....	82
PUMP & MOTOR SOLENOID OPERATION (POWER DOWN).....	83
HYDRAULIC SCHEMATIC (GRAVITY DOWN).....	84
HYDRAULIC SCHEMATIC (POWER DOWN) .....	85
ELECTRICAL SCHEMATIC (GRAVITY DOWN) .....	86
ELECTRICAL SCHEMATIC (POWER DOWN) .....	87

<b>RECOMMENDED BOLT TORQUES .....</b>	<b>88</b>
<b>TROUBLESHOOTING .....</b>	<b>90</b>
PLATFORM WILL NOT RAISE & MOTOR WILL NOT RUN .....	90
PLATFORM WILL NOT RAISE, BUT MOTOR RUNS .....	91
PLATFORM RAISES BUT LEAKS DOWN .....	92
PLATFORM RAISES PARTIALLY AND STOPS.....	94
LIFTGATE WILL NOT LIFT RATED CAPACITY .....	96
PLATFORM WILL NOT LOWER, LOWERS TOO SLOWLY, OR TOO QUICKLY .....	98

Comply with the following **WARNINGS** while maintaining Liftgates. See Operation Manual for operating safety requirements.

## **WARNING**

- Read and understand the instructions in this **Maintenance Manual** before performing maintenance on the Liftgate.
- Before operating the Liftgate, read and understand the operating instructions in **Operation Manual**.
- Comply with all **WARNING** and instruction decals attached to the Liftgate.
- Keep decals clean and legible. If decals are illegible or missing, replace them. Free replacement decals are available from **Maxon Parts Department**.
- Consider the safety and location of bystanders and location of nearby objects when operating the Liftgate. Stand to one side of the platform while operating the Liftgate.
- Do not allow untrained persons to operate the Liftgate.
- Do not stand, or allow obstructions, under the platform when lowering the Liftgate. **Be sure your feet are clear of the Liftgate.**
- **Keep fingers, hands, arms, legs, and feet clear of moving Liftgate parts (and platform edges) when operating the Liftgate.**
- **Correctly stow platform when not in use. Extended platforms could create a hazard for people and vehicles passing by.**
- **Disconnect Liftgate power cable from battery** before repairing or servicing Liftgate.
- Wear appropriate safety equipment such as protective eyeglasses, faceshield and clothing while performing maintenance on the Liftgate and handling the battery. Debris from drilling and contact with battery acid may injure unprotected eyes and skin.
- Be careful working by an automotive type battery. Make sure the work area is well ventilated and there are no flames or sparks near the battery. Never lay objects on the battery that can short the terminals together. If battery acid gets in your eyes, immediately seek first aid. If acid gets on your skin, immediately wash it off with soap and water.
- If an emergency situation arises (vehicle or Liftgate) while operating the Liftgate, release the control toggle switch to stop the Liftgate.
- A correctly installed Liftgate operates smoothly and reasonably quiet. The only noticeable noise during operation comes from the pump unit while the platform is raised. Listen for scraping, grating and binding noises and correct the problem before continuing to operate Liftgate.
- If it is necessary to stand on the platform while maintaining the Liftgate, keep your feet and any objects clear of the inboard edge of the platform. Your feet or objects on the platform can become trapped between the platform and the Liftgate extension plate.
- Never perform unauthorized modifications on the Liftgate. Modifications may result in early failure of the Liftgate and may create hazards for Liftgate operators and maintainers.
- Use only **Maxon Authorized Parts** for replacement parts. Provide Liftgate model and serial number information with your parts order. Order replacement parts from:

**MAXON LIFT CORP. Customer Service**  
**11921 Slauson Ave., Santa Fe Springs, CA 90670**  
**Phone: (800) 227-4116**

- To order parts by e-mail, submit orders to **[cservice@maxonlift.com](mailto:cservice@maxonlift.com)**.

- Recommended practices for welding on steel parts are contained in the current **AWS (American Welding Society) D1.1 Structural Welding Code - Steel**. Damage to Liftgate and/or vehicle, and personal injury could result from welds that are done incorrectly.
- Recommended practices for welding on aluminum parts are contained in the current **AWS (American Welding Society) D2.1 Structural Welding Code - Aluminum**. Damage to Liftgate and/or vehicle, and personal injury could result from welds that are done incorrectly.



THIS PAGE INTENTIONALLY LEFT BLANK

# LIFTGATE TERMINOLOGY

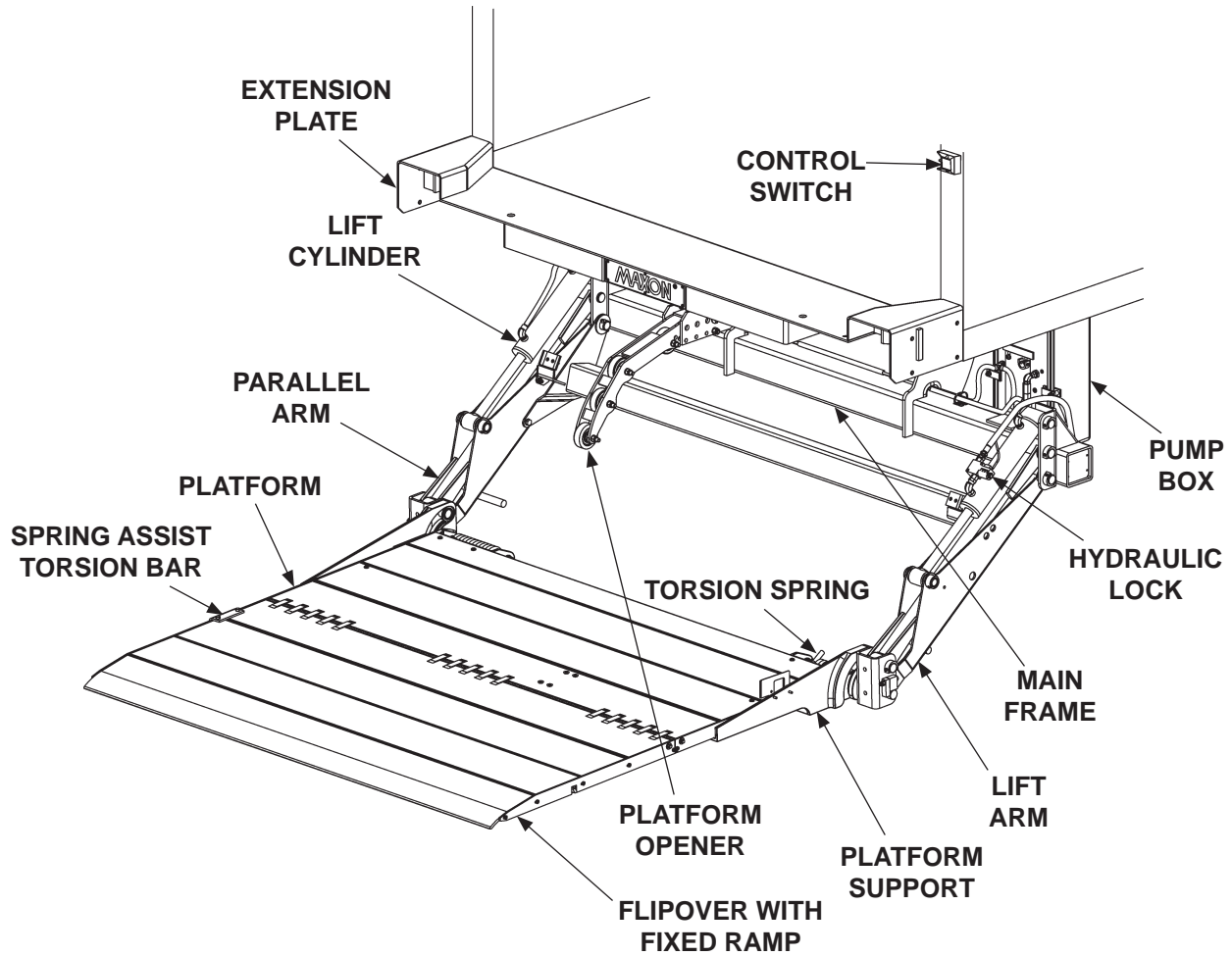

**MAXON**<sup>®</sup>

11921 Slauson Ave. Santa Fe Springs, CA. 90670 (800) 227-4116 FAX (888) 771-7713

## PERIODIC MAINTENANCE PERIODIC MAINTENANCE CHECKS

### **WARNING**

**Never operate the Liftgate if parts are loose or missing.**

**NOTE:** Make sure vehicle is parked on level ground while performing the maintenance checks.

### **Quarterly or 1250 Cycles (whichever occurs first)**

Check the hydraulic fluid level in the pump reservoir. Refer to the **CHECKING HYDRAULIC FLUID** procedure in the **PERIODIC MAINTENANCE** section.

If hydraulic fluid appears contaminated, refer to the **CHANGING HYDRAULIC FLUID** procedure in the **PERIODIC MAINTENANCE** section.

Keep track of the grade of hydraulic fluid in the pump reservoir. Never mix two different grades of fluid.

Check all hoses and fittings for chafing and fluid leaks. Make sure hydraulic lock is in place and undamaged. Replace if necessary.

Check electrical wiring for chafing and make sure wiring connections are tight and free of corrosion.

Check that all **WARNING and instruction decals, nonskid stickers, and safety striping** are in place. Also, make sure decals are legible and decals, nonskid, and safety striping are clean and undamaged.

Check that all roll pins are in place and protrude evenly from both sides of hinge pin collar. Replace roll pins if necessary.

Check both platform torsion springs to make sure there is grease between the coils. If grease is not visible in the valley between each coil, apply spray-on white lithium grease.

### **CAUTION**

**Damaged cylinder seals and contaminated hydraulic fluid can result from painting the polished portion of the cylinder rod. To prevent damage, protect the exposed polished portion of the cylinder rod while painting.**

Check for rust and oily surfaces on Liftgate. If there is rust or oil on Liftgate, clean it off. Touch up the paint where bare metal is showing. MAXON recommends using the aluminum primer touchup paint kit, P/N 908119-01.

### **Semi-annually or 2500 Cycles (whichever occurs first)**

Visually check the platform hinge pins for excessive wear and broken welds. See **PARTS BREAKDOWN** section for replacement parts. Also, do the **Quarterly or 1250 Cycles** maintenance checks.

# PERIODIC MAINTENANCE

## PERIODIC MAINTENANCE CHECKS - Continued

### Annually or 5000 Cycles (whichever occurs first)

Visually check the entire Liftgate for excessively worn parts and broken welds, especially hinge pins. See **PARTS BREAKDOWN** section for replacement parts.

Check the platform and flipover as follows. Unfold the platform and flipover. Raise the platform to vehicle bed height and then lower it to the ground. Check if the shackles and tip of flipover touch the ground at the same time (**FIG. 12-1**). With the shackles touching, tip of a ramp-style flipover may be no more than 1/4" above the ground. A flipover equipped with retention ramp may have a maximum 2" of ground clearance at the tip of the flipover.

If the shackles are 1" or more above the ground when the tip of the flipover is touching the ground, perform the **ADJUST PLATFORM** procedure in the **Installation Manual (M-04-06)**. If the adjustment does not correct the problem, check pins and bearings at the pivot points on both sides of the Liftgate (**see FIG. 12-3**). See **PARTS BREAKDOWN** section for replacement parts.

Also, for aluminum flipovers equipped with single retention ramp and for steel flipovers, ensure latch is in place, undamaged, and working correctly. See **PARTS BREAKDOWN** section for replacement parts.

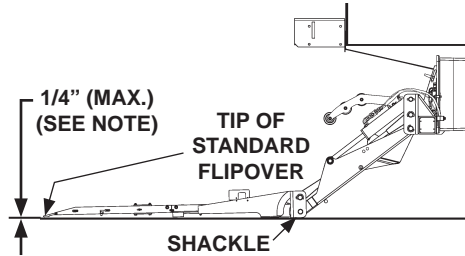

**PLATFORM & SHACKLES TOUCHING THE GROUND**  
**FIG. 12-1**

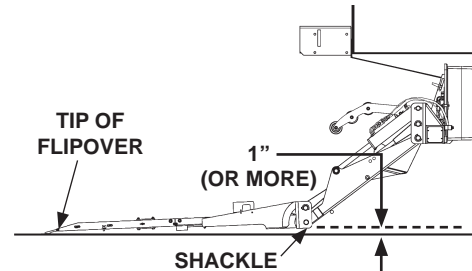

**SHACKLES NOT TOUCHING THE GROUND**  
**FIG. 12-2**

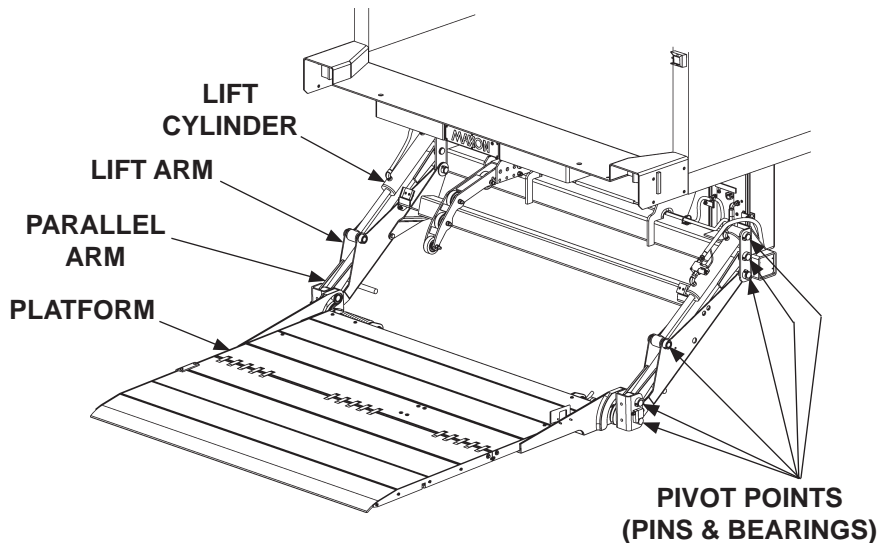

**PIVOT POINTS TO CHECK**  
**FIG. 12-3**

## Annually or 5000 Cycles - Continued

To prevent unnecessary wear on parallel arms, check for worn thrust bearings as follows. Position the platform 1"-2" above ground (**FIG. 13-2A**). Push against the shackle (**Item 1, FIG. 13-2B**) and measure clearance (**Item 1, FIG. 13-2B**). Then, push against other side of shackle (**Item 2, FIG. 13-2B**) and measure clearance (**Item 2, FIG. 13-2B**). Repeat for LH side shackle. If clearance is less than 0.050", replace thrust bearing. See **PARTS BREAKDOWN** section for replacement parts.

Also, do the **Semi-annual or 2500 Cycles** and **Quarterly or 1250 Cycles** checks.

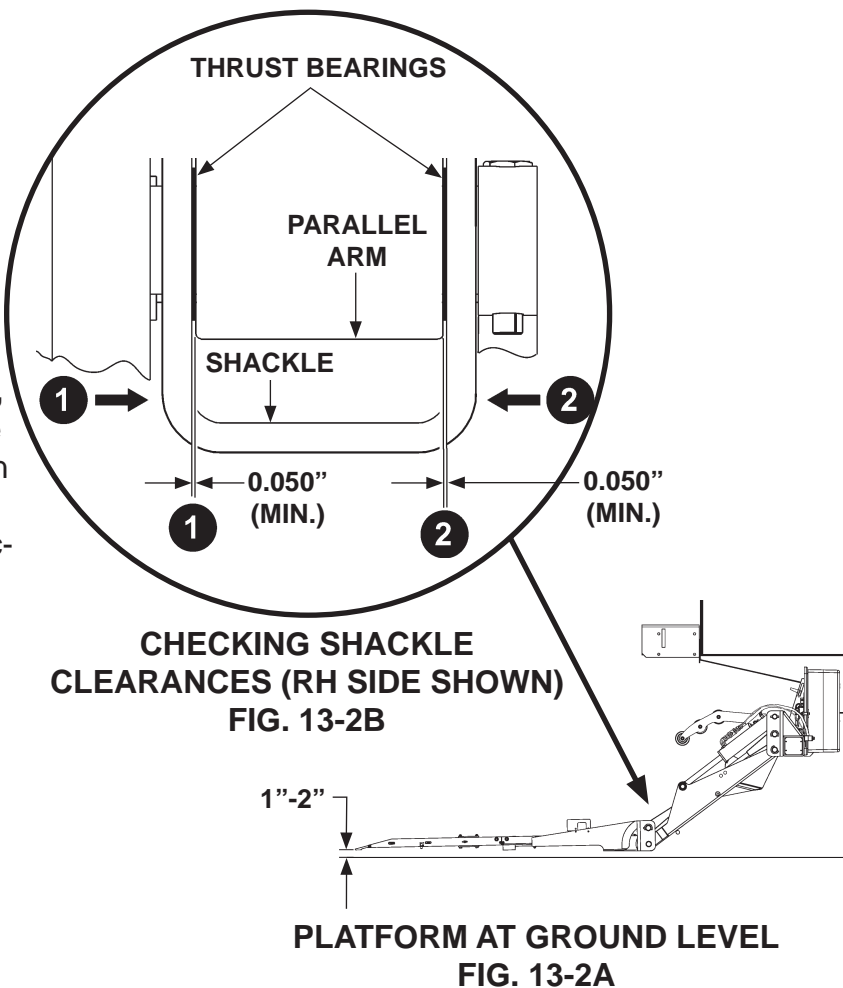

# PERIODIC MAINTENANCE

## PERIODIC MAINTENANCE CHECKLIST

**NOTE:** Make sure vehicle is parked on level ground while performing maintenance checks.

### Quarterly or 1250 Cycles (whichever occurs first)

- Check the level and condition of the hydraulic fluid.
- Visually check all hoses and fittings for chafing and fluid leaks, and check hydraulic lock.
- Check electrical wiring for chafing and make sure wiring connections are tight and free of corrosion.
- Check that all **WARNING and instruction decals, nonskid stickers, and safety striping** are in place. Also, make sure decals are legible and decals, nonskid, and safety striping are clean and undamaged.
- Check that all roll pins are in place and protrude evenly from both sides of hinge pin collar. Replace roll pins if necessary.
- Check for rust and oily surfaces on Liftgate. If there is rust or oil on Liftgate or if the Liftgate is dirty, clean it off. Touch up the paint where bare metal is showing.
- Check both platform torsion springs to make sure there is grease in the valley between each coil. If grease is not visible, apply spray-on white lithium grease to the valley between each coil.

### Semi-annually or 2500 Cycles (whichever occurs first)

- Visually check the platform hinge pins for excessive wear and broken welds.
- Do the **Quarterly or 1250 Cycles Checks** on this checklist.

### Annually or 5000 Cycles (whichever occurs first)

- Visually check the entire Liftgate for excessively worn parts and broken welds, especially hinge pins.
- Visually check platform & flipover. (See the **PERIODIC MAINTENANCE CHECKS** topic for more information.)
- Visually check the thrust bearings on the shackles.
- Do the **Semi-annual or 2500 Cycles Checks** on this checklist.
- Do the **Quarterly or 1250 Cycles Checks** on this checklist.

For more details pertaining to this checklist, see the **PERIODIC MAINTENANCE CHECKS** section in this Maintenance Manual.

**MAXON**<sup>®</sup>

11921 Slauson Ave. Santa Fe Springs, CA. 90670 (800) 227-4116 FAX (888) 771-7713

THIS PAGE INTENTIONALLY LEFT BLANK

# PERIODIC MAINTENANCE

## CHECKING HYDRAULIC FLUID

**MAXON**

11921 Slauson Ave. Santa Fe Springs, CA. 90670 (800) 227-4116 FAX (888) 771-7713

### CAUTION

Keep dirt, water and other contaminants from entering the hydraulic system. Before opening the hydraulic fluid reservoir filler cap, drain plug and hydraulic lines, clean up contaminants that can get in the openings. Also, protect the openings from accidental contamination.

**NOTE:** Use correct grade of hydraulic fluid for your location.

**+50 to +120 Degrees F - Grade ISO 32**

**Below + 70 Degrees F - Grade ISO 15 or MIL-H-5606**

See TABLES 17-1 & 17-2 for recommended brands.

1. Unbolt and remove pump cover (FIG. 16-1).
2. Check the hydraulic fluid level in reservoir as follows. With Liftgate stowed, or platform at vehicle bed height, level should be as shown in FIG. 16-2.

**NOTE:** If the hydraulic fluid in the reservoir is contaminated, do the **CHANGING HYDRAULIC FLUID** procedure in this section.

3. If needed, add fluid to the reservoir as follows. Pull out (no threads) filler cap (FIG. 16-2). Fill the reservoir with hydraulic fluid to level shown in FIG. 16-2. Reinstall filler cap (FIG. 16-2).

### CAUTION

Pump cover must be correctly secured to prevent it from becoming a hazard. To secure pump cover, the long side of the holder flats must butt against pump cover as shown in the illustration.

4. Bolt on the pump cover as shown in FIG. 16-1. Torque the 5/16"-18 cover bolts from 10 to 14 lbs.-ft.

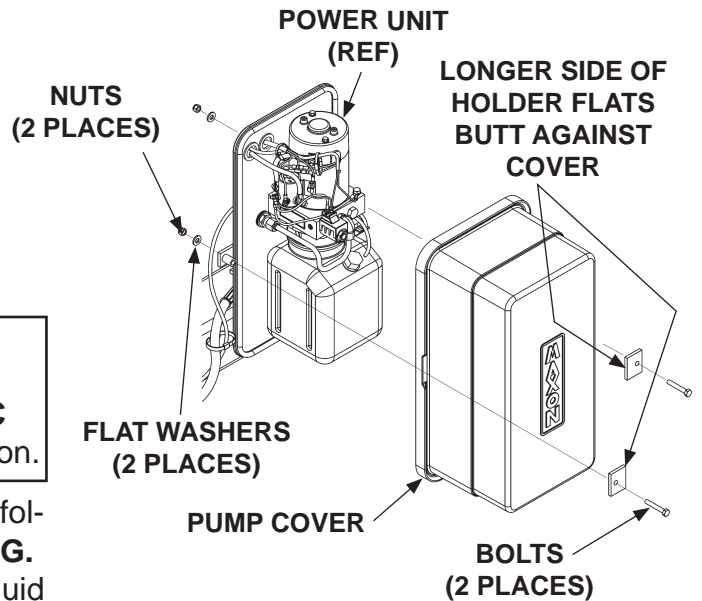

**UNBOLTING / BOLTING PUMP COVER**  
FIG. 16-1

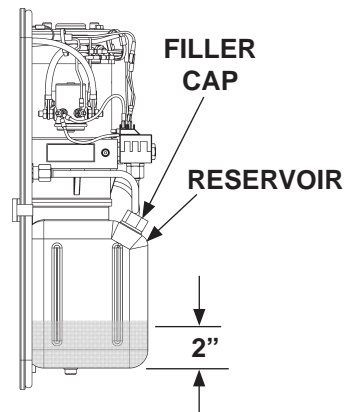

**POWER UNIT FLUID LEVEL**  
FIG. 16-2



ISO 32 HYDRAULIC OIL	
RECOMMENDED BRANDS	PART NUMBER
AMSOIL	AWH-05
CHEVRON	HIPERSYN 32
KENDALL	GOLDEN MV
SHELL	TELLUS T-32
EXXON	UNIVIS N-32
MOBIL	DTE-13M, DTE-24, HYDRAULIC OIL-13

**TABLE 17-1**

ISO 15 OR MIL-H-5606 HYDRAULIC OIL	
RECOMMENDED BRANDS	PART NUMBER
AMSOIL	AWF-05
CHEVRON	FLUID A, AW-MV-15
KENDALL	GLACIAL BLU
SHELL	TELLUS T-15
EXXON	UNIVIS HVI-13
MOBIL	DTE-11M
ROSEMEAD	THS FLUID 17111

**TABLE 17-2**

# PERIODIC MAINTENANCE

## CHANGING HYDRAULIC FLUID

### CAUTION

Keep dirt, water and other contaminants from entering the hydraulic system. Before opening the hydraulic fluid reservoir filler cap, drain plug and hydraulic lines, clean up contaminants that can get in the openings. Also, protect the openings from accidental contamination.

**NOTE:** Use correct grade of hydraulic fluid for your location.

**+50 to +120 Degrees F - Grade ISO 32**

**Below + 70 Degrees F - Grade ISO 15 or MIL-H-5606**

See TABLES 17-1 & 17-2 for recommended brands.

### GRAVITY DOWN & POWER DOWN LIFTGATES

1. Unbolt and remove pump cover (FIG. 18-1). Place empty 5 gallon bucket under drain plug (FIG. 18-2).

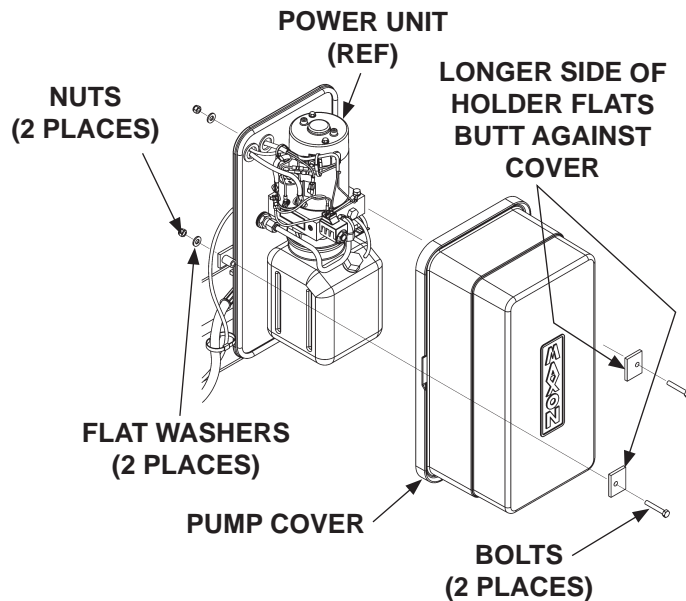

**UNBOLTING PUMP COVER**

**FIG. 18-1**

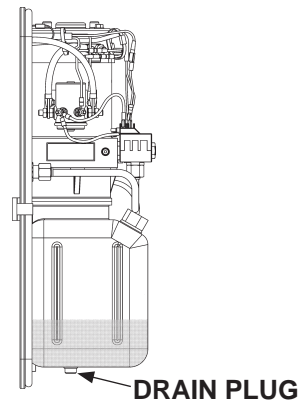

**FIG. 18-2**

**MAXON**

11921 Slauson Ave. Santa Fe Springs, CA. 90670 (800) 227-4116 FAX (888) 771-7713

## GRAVITY DOWN LIFTGATES

1. Lower platform to ground. Pull out (no threads) drain plug (**FIG. 19-1**). Drain hydraulic fluid from system. Reinstall drain plug.
2. Pull out (no threads) filler cap (**FIG. 19-1**) and refill reservoir with hydraulic fluid to level shown in **FIG. 19-1**. Reinstall filler cap (**FIG. 19-1**).
3. Stow the Lift and do the **CHECKING HYDRAULIC FLUID** procedure in this section of the manual.

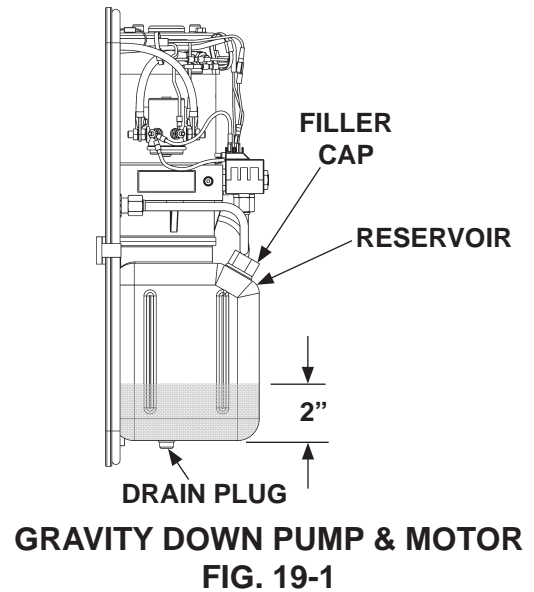

## POWER DOWN LIFTGATES

1. Open and raise platform to vehicle bed height. Pull out (no threads) drain plug (**FIG. 19-1**). Drain hydraulic fluid.

**NOTE:** MAXON recommends using dielectric grease on all electrical connections.

2. Disconnect the white wire (**FIG. 19-2**) from starter solenoid. Lower the platform while draining the remaining hydraulic fluid from system. Reinstall drain plug. Reconnect the white wire to starter solenoid.
3. Pull out (no threads) filler cap (**FIG. 19-1**) and refill reservoir with hydraulic fluid to level shown in **FIG. 19-1**. Reinstall filler cap (**FIG. 19-1**).
4. Stow the Lift and do the **CHECKING HYDRAULIC FLUID** procedure in this section of the manual.

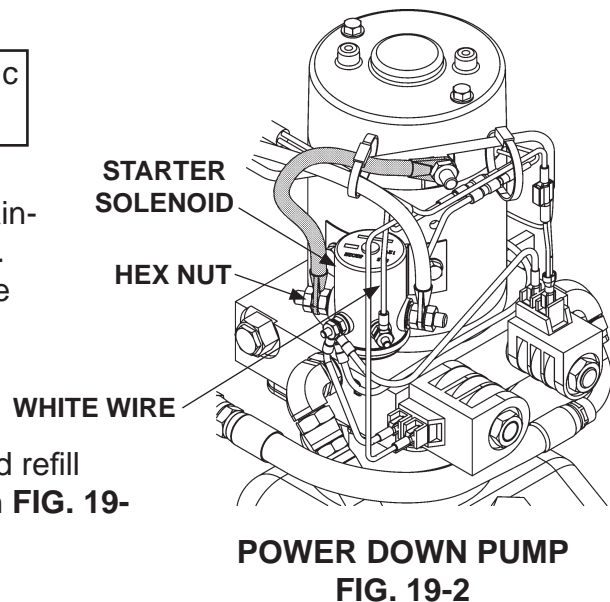

# PERIODIC MAINTENANCE

## GRAVITY DOWN & POWER DOWN LIFTGATES

### CAUTION

Pump cover must be correctly secured to prevent it from becoming a hazard. To secure pump cover, the long side of the holder flats must butt against pump cover as shown in the illustration.

Bolt on the pump cover as shown in FIG. 20-1. Torque the 5/16"-18 cover bolts from **10 to 14 lbs.-ft.**

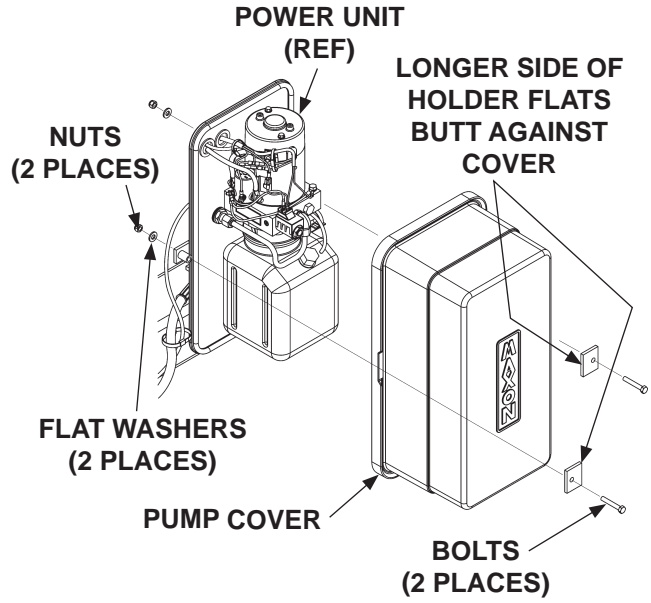

**BOLTING ON PUMP COVER  
FIG. 20-1**

**MAXON**

11921 Slauson Ave. Santa Fe Springs, CA. 90670 (800) 227-4116 FAX (888) 771-7713

## PLATFORM TORSION SPRING ADJUSTMENT

**NOTE:** Perform the following adjustment if platform feels heavy as you start to fold it for stowing. If adjusted as follows, the torsion springs will reduce the amount of effort you need to start folding the platform.

1. Make sure vehicle is parked on level ground. **LOWER** the Liftgate about 1" above the ground (**FIG. 21-1**).

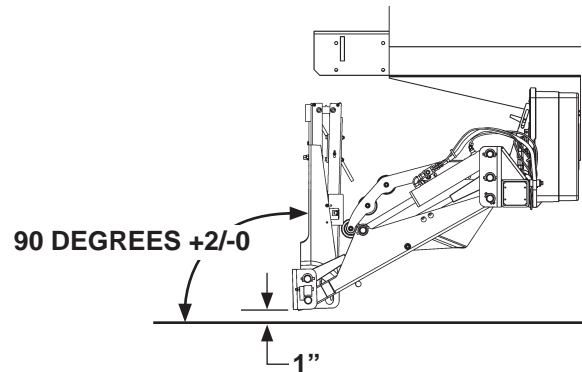

**LIFTGATE OFF THE GROUND**  
**FIG. 21-1**

**! WARNING**  
To prevent possible injury and damage to Liftgate, have another qualified person hold platform in position to keep it from falling open.

2. Position platform and flipover to 90 degrees, +2 / -0 degrees (**FIG. 21-1**). Get a second person to hold the platform in place while you take measurements.
3. On RH side of platform, position the torsion spring so it rests on pin (**FIGS. 21-2A & 21-2B**). Make sure long leg of torsion spring is parallel to chamfered surface on support block (**FIG. 21-2B**). Measure gap "H" between leg of the torsion spring and support block (**FIG. 21-2B**). Repeat for torsion spring on LH side of platform.

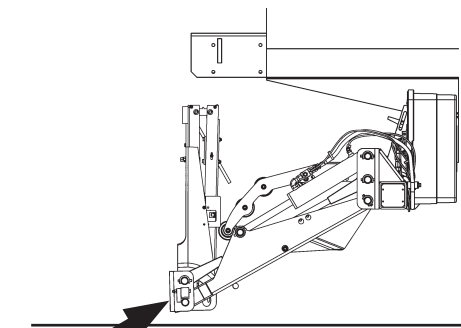

**PIN LOCATION**  
**FIG. 21-2A**

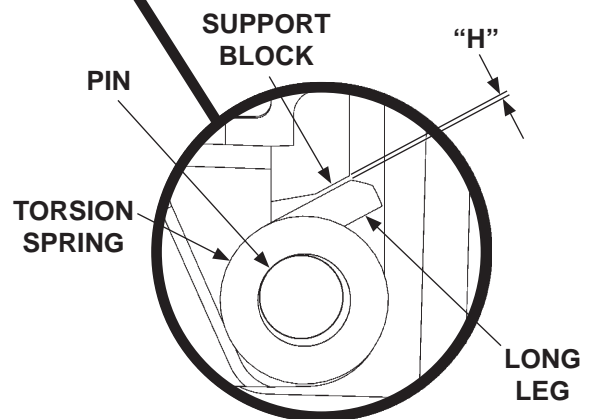

**CORRECTLY POSITIONED**  
**PLATFORM & FLIPOVER**  
**FIG. 21-2B**

# PERIODIC MAINTENANCE

## PLATFORM TORSION SPRING ADJUSTMENT - Continued

**NOTE:** If there is little or no gap, a shim is not required. Skip to step 7.

- Fabricate 2 shims from A-36 steel as shown in **FIG 22-1**. The thickness must be equal to the “H” measurement taken in the previous step and an added 1/16”. For example, if you measured 1/8” for “H”, add another 1/16” to make the shim 3/16” thick.

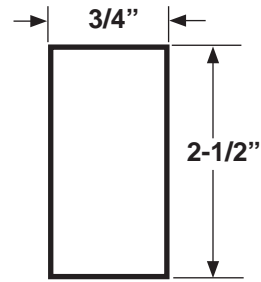

**SHIM (THICKNESS “H”)  
MADE FROM STEEL FLAT  
FIG. 22-1**

### CAUTION

Heat from welding near the platform torsion springs can weaken the springs. Cover the torsion springs with a wet cloth before welding.

- Weld 1 shim (**FIG. 22-2**) to support block on RH side of platform as shown in **FIG. 22-2**. Repeat for support block on LH side of platform.

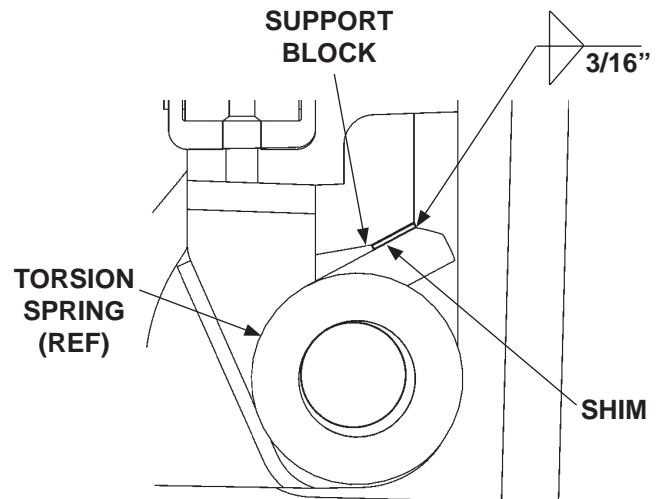

**WELDING SHIM ON  
SUPPORT BLOCK  
FIG. 22-2**

**MAXON**

11921 Slauson Ave. Santa Fe Springs, CA. 90670 (800) 227-4116 FAX (888) 771-7713

6. **LOWER** platform to the ground. Make sure platform easily folds (**FIG. 23-1**) and unfolds (**FIG. 23-2**).

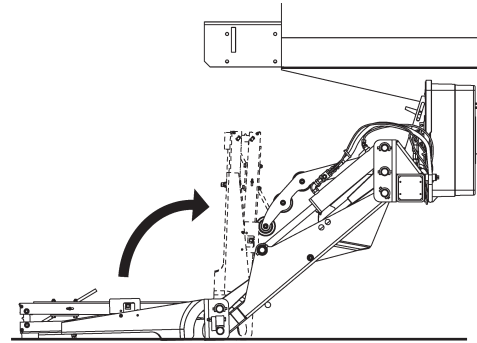

**FOLDING PLATFORM**  
**FIG. 23-1**

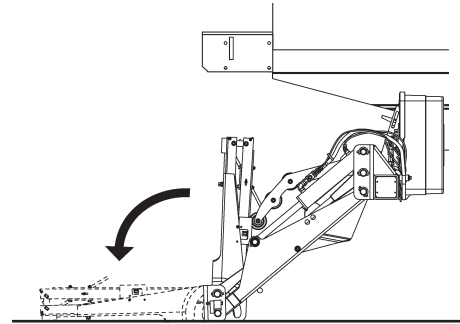

**UNFOLDING PLATFORM**  
**FIG. 23-2**

**CAUTION**  
Stow Liftgate under hydraulic pressure.

7. Fold platform and stow Liftgate (**FIG. 23-3**).

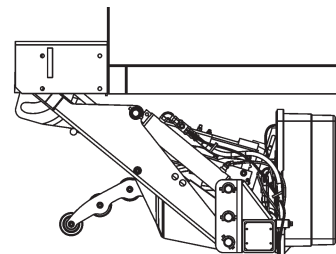

**LIFTGATE STOWED**  
**FIG. 23-3**

# PERIODIC MAINTENANCE

## REPLACING PLATFORM TORSION SPRING

**NOTE:** The following procedure shows how to replace torsion spring on RH side of platform. Use this procedure for replacing torsion spring on the LH side.

1. Fold flipover onto platform.
2. Fold platform.
3. Raise Liftgate to a convenient work height to gain access and release tension on the torsion spring.

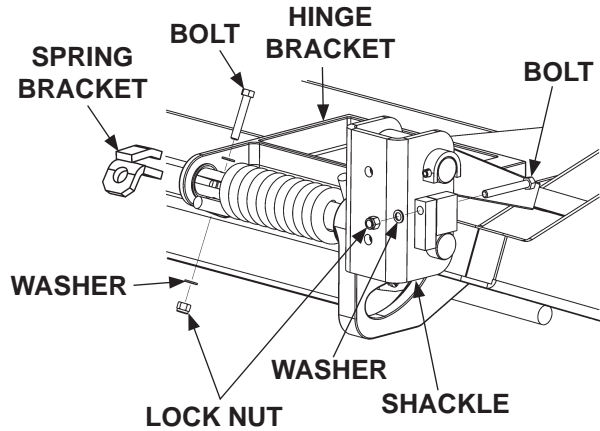

FIG. 24-1

### ⚠ CAUTION

To prevent injury and equipment damage, make sure there is no tension on torsion spring before removing hinge pin.

4. Unbolt hinge pin from shackle and spring bracket (FIG. 24-1). Remove bolts, washers, and lock nuts. Drive the hinge pin outboard toward the shackle just enough to free the torsion spring (FIG. 24-2). Remove the torsion spring.

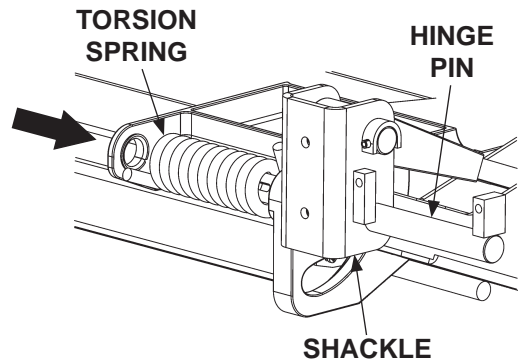

FIG. 24-2



5. Install the torsion spring as shown in **FIG. 25-1**. Make sure the long leg of the spring is inserted in the spring bracket (**FIG. 25-1**). Make sure the short end of the spring is visible and resting against the hinge bracket (**FIG. 25-1**).

6. Drive the hinge pin into correct position through the hinge bracket as shown in **FIG. 25-1**. Line up the bolt hole in the hinge pin with the hole in the shackle and spring bracket. Bolt the hinge pin to hinge bracket and spring bracket with bolts, washers, lock nuts (**FIG. 25-1**). Torque the 3/8"-16 spring pin bolt and 3/8"-16 spring bracket bolt **35 to 52 lbs.-ft.**

7. Operate the Liftgate according to instructions in **Operation Manual** to make sure it operates correctly.

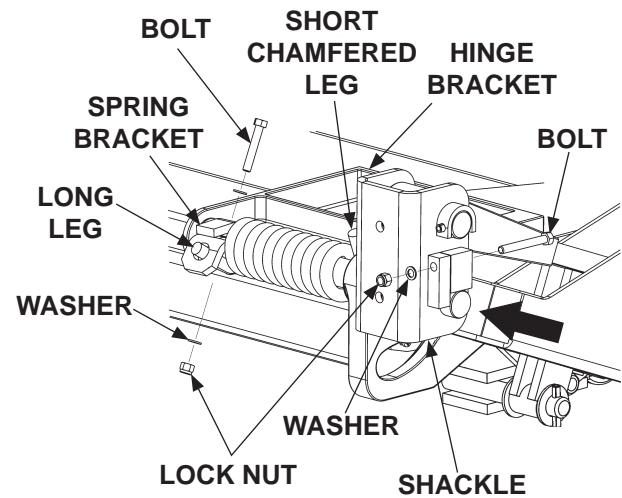

**FIG. 25-1**

# PARTS BREAKDOWN

## MAIN ASSEMBLY: GPTLR-25 & GPTLR-33 (ALUMINUM PLATFORM)

**MAXON**

11921 Slauson Ave. Santa Fe Springs, CA. 90670 (800) 227-4116 FAX (888) 771-7713

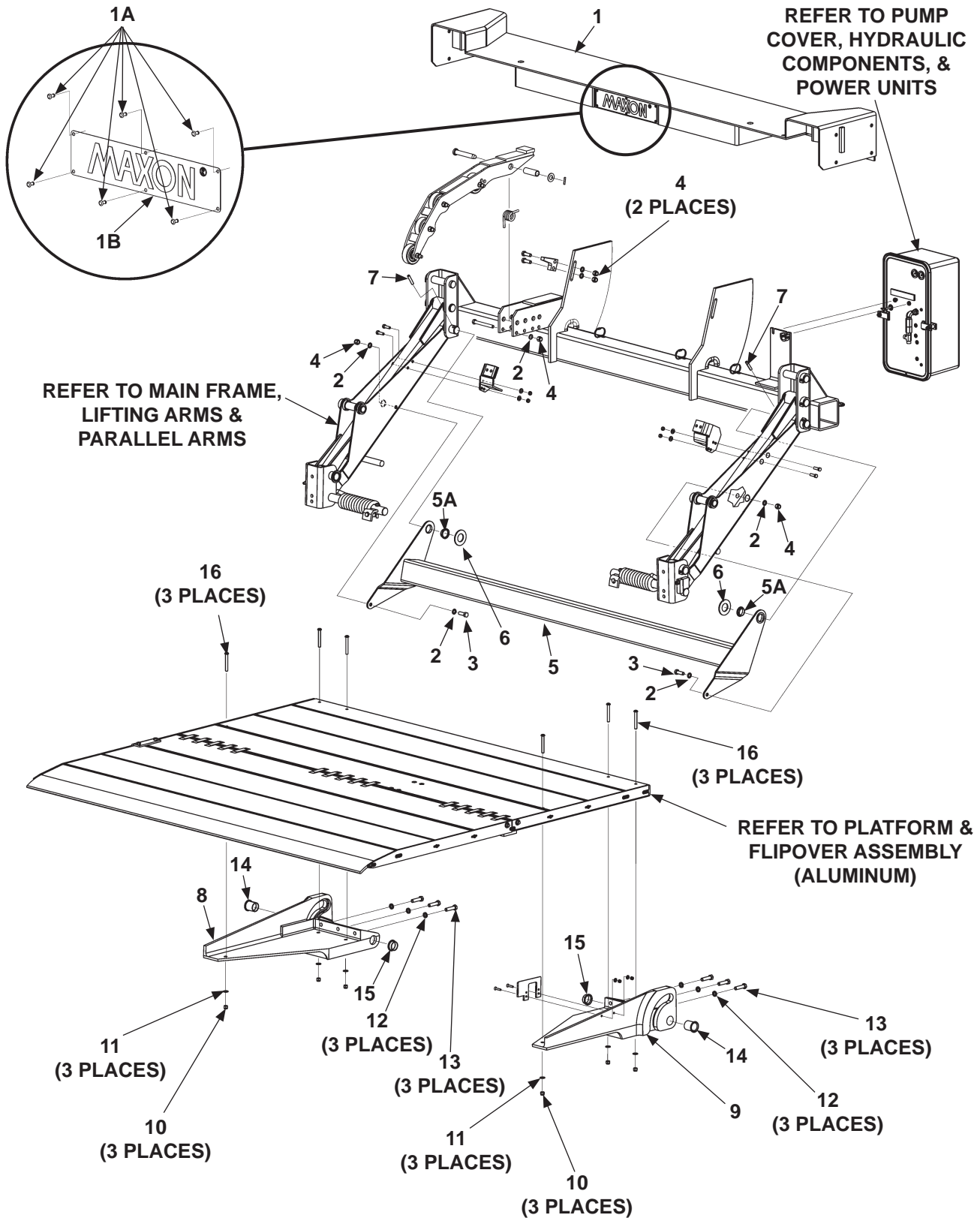

ITEM	QTY.	PART NO.	DESCRIPTION
1	1	281090-01	EXTENSION PLATE ASSEMBLY (96" WIDE)
		281090-02	EXTENSION PLATE ASSEMBLY (102" WIDE)
1A	6	207644	RIVET, 3/16" X .40" GRIP
1B	1	050175	MAXON PLATE
2	5	902000-14	FLAT WASHER, 1/2"
3	2	900035-3	CAP SCREW, 1/2"-13 X 1-1/2" LG.
4	5	901010	LOCK NUT, 1/2"-13
5	1	281580-01	ICC BUMPER (96" WIDE)
		281580-02	ICC BUMPER (102" WIDE)
5A	2	908088-01	BEARING, FLANGED
6	2	902013-21	FLAT WASHER, 1-3/8"
7	2	221416	ROLL PIN, 3/8" X 2" LG.
8	1	280981-01	SUPPORT, LH
9	1	280981-02	SUPPORT, RH
10	6	901002	LOCK NUT, 3/8"-16
11	6	902013-11	FLAT WASHER, 3/8"
12	6	902011-6	LOCK WASHER, 1/2"
13	6	900035-5	CAP SCREW, 1/2"-13 X 2" LG.
14	2	908026-01	BEARING, 1-3/4" LG.
15	2	908008-02	BEARING, 5/8" LG.
16	6	900064-08	BUTTONHEAD SCREW, 3/8"-16 X 3-1/4" LG.

# PARTS BREAKDOWN

## MAIN ASSEMBLY: GPTLR-25 & GPTLR-33 (ALUMINUM PLATFORM) - Continued

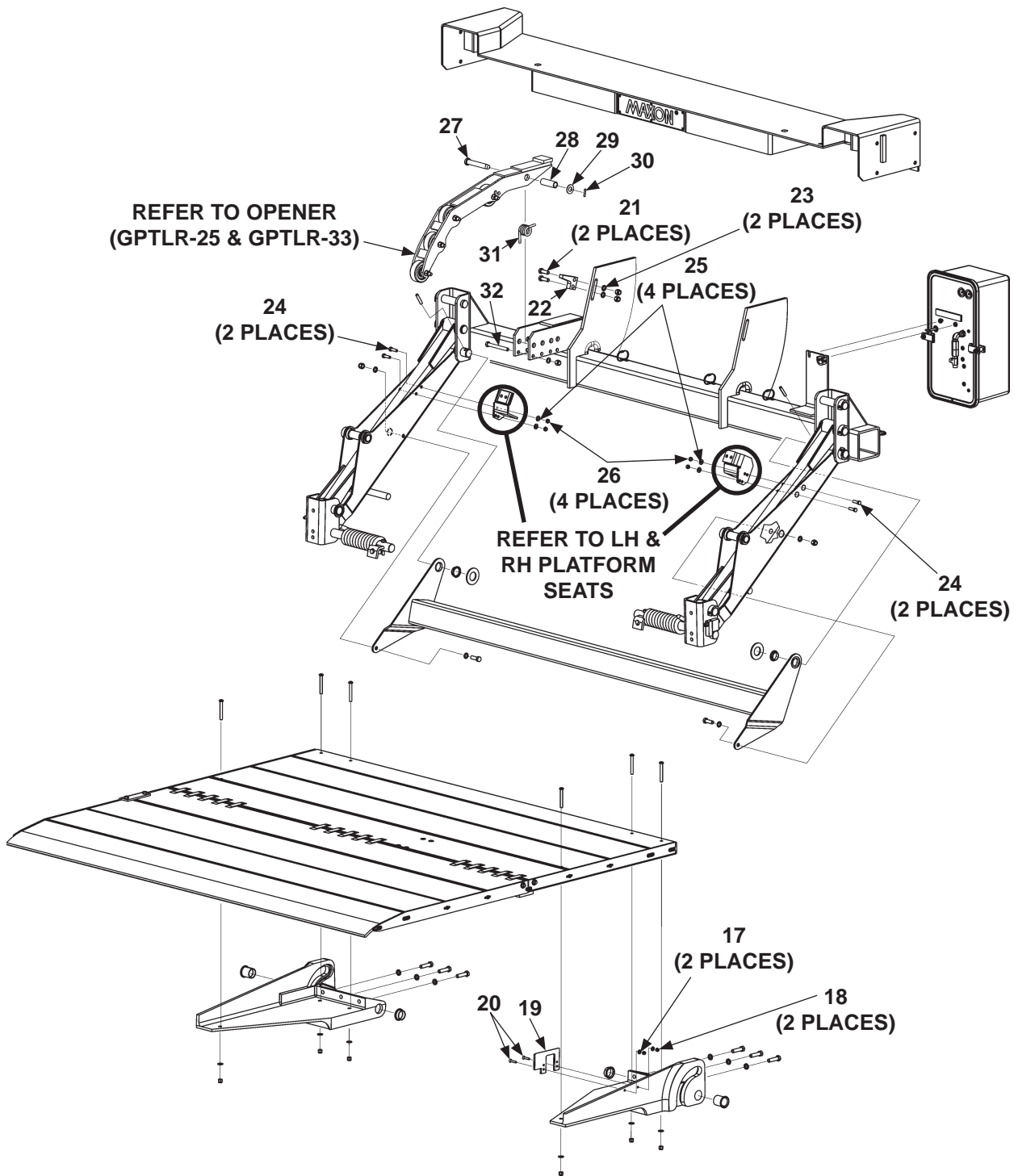

**MAXON**<sup>®</sup>

11921 Slauson Ave. Santa Fe Springs, CA. 90670 (800) 227-4116 FAX (888) 771-7713

ITEM	QTY.	PART NO.	DESCRIPTION
17	2	902013-09	FLAT WASHER, 1/4"
18	2	901000	LOCK NUT, 1/4"-20
19	1	281154-01	LATCH BRACKET
20	2	900044-7	SOCKET SCREW, 1/4"-20 X 1-1/4" LG.
21	2	900035-7	CAP SCREW, 1/2"-13 X 2-1/2" LG.
22	1	281673-01	STOP BLOCK
23	2	902000-16	FLAT WASHER, 5/8"
24	4	900014-5	CAP SCREW, 3/8"-16 X 1-1/4" LG, GRADE 8
25	4	902000-10	FLAT WASHER, 3/8"
26	4	901016-4	LOCK NUT, 3/8"-16
27	1	282277-01	OPENER PIN
28	1	092046-10	BUSHING
29	1	902000-20	FLAT WASHER, 3/4"
30	1	905033-2	ROLL PIN, 1/4" X 1-1/4"
31	1	282272-01	OPENER TORSION SPRING
32	1	900035-12	CAP SCREW, 1/2"-13 X 4-1/2"

# PARTS BREAKDOWN

## MAIN ASSEMBLY: GPTLR-44 & GPTLR-55 (ALUMINUM PLATFORM)

**MAXON®**

11921 Slauson Ave. Santa Fe Springs, CA. 90670 (800) 227-4116 FAX (888) 771-7713

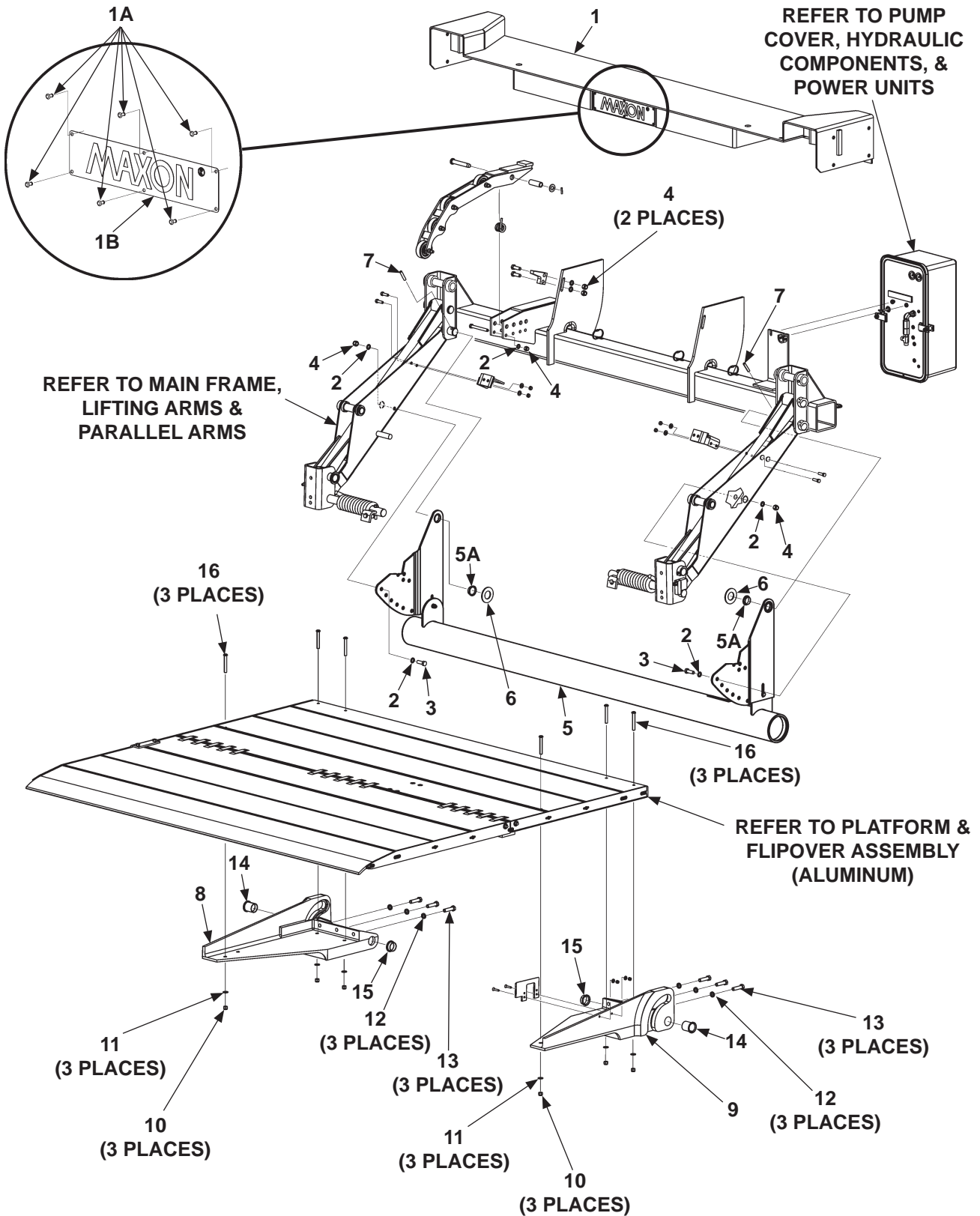

ITEM	QTY.	PART NO.	DESCRIPTION
1	1	281120-01	EXTENSION PLATE ASSEMBLY (96" WIDE)
		281120-02	EXTENSION PLATE ASSEMBLY (102" WIDE)
1A	6	207644	RIVET, 3/16" X .40" GRIP
1B	1	050175	MAXON PLATE
2	5	902000-14	FLAT WASHER, 1/2"
3	2	900035-3	CAP SCREW, 1/2"-13 X 1-1/2" LG.
4	5	901010	LOCK NUT, 1/2"-13
5	1	281399-01	UNDERRIDE (96" WIDE)
		281399-02	UNDERRIDE (102" WIDE)
5A	2	908088-01	BEARING, FLANGED
6	2	902013-21	FLAT WASHER, 1-3/8"
7	2	221416	ROLL PIN, 3/8" X 2" LG.
8	1	281340-01	SUPPORT, LH
9	1	281340-02	SUPPORT, RH
10	6	901002	LOCK NUT, 3/8"-16
11	6	902013-11	FLAT WASHER, 3/8"
12	6	902011-6	LOCK WASHER, 1/2"
13	6	900035-5	CAP SCREW, 1/2"-13 X 2" LG.
14	2	908026-01	BEARING, 1-3/4" LG.
15	2	908008-02	BEARING, 5/8" LG.
16	6	900064-08	BUTTONHEAD SCREW, 3/8"-16 X 3-1/4" LG.

# PARTS BREAKDOWN

## MAIN ASSEMBLY: GPTLR-44 & GPTLR-55 (ALUMINUM PLATFORM) - Continued

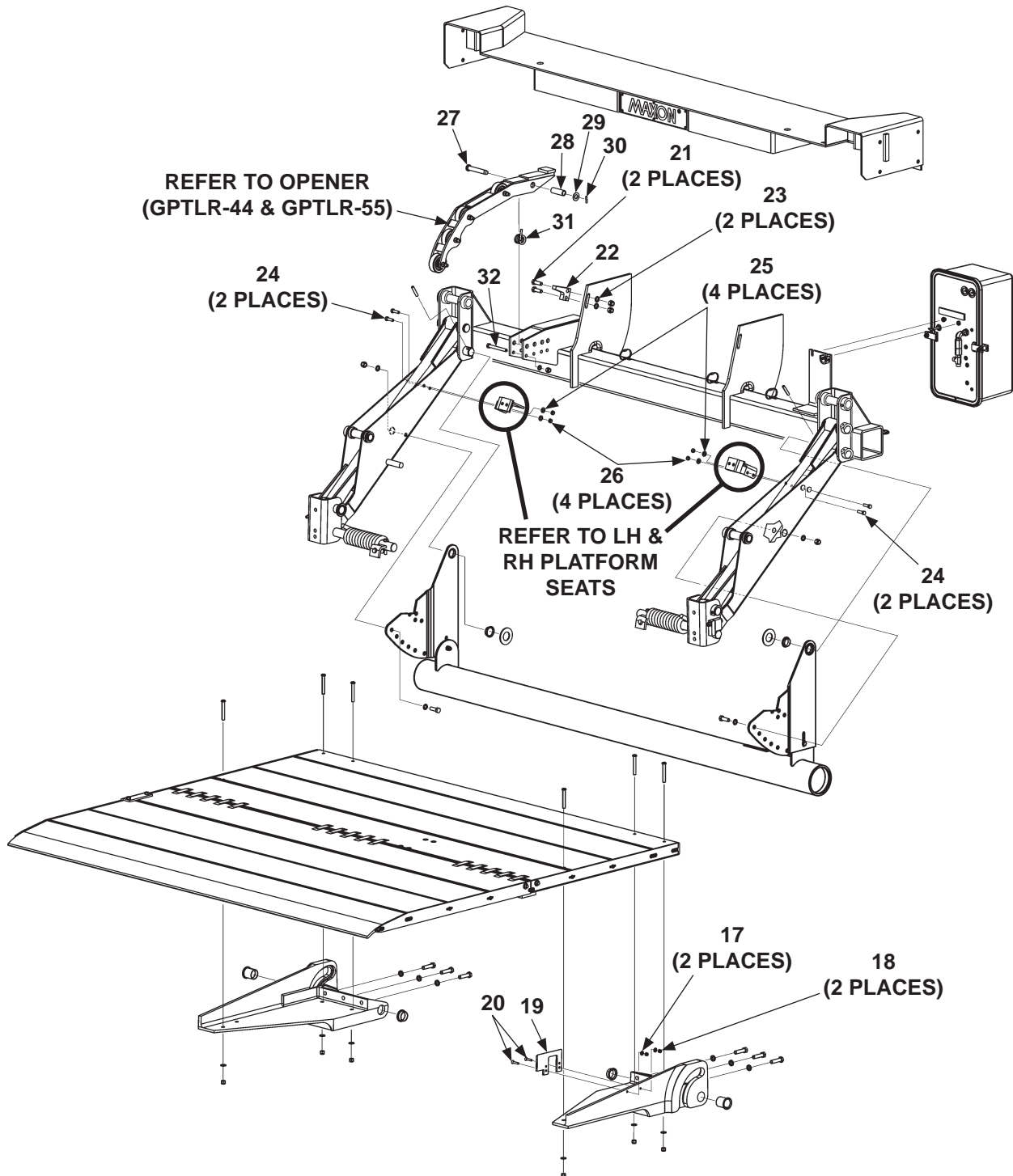

**MAXON**

11921 Slauson Ave. Santa Fe Springs, CA. 90670 (800) 227-4116 FAX (888) 771-7713



ITEM	QTY.	PART NO.	DESCRIPTION
17	2	902013-09	FLAT WASHER, 1/4"
18	2	901000	LOCK NUT, 1/4"-20
19	1	281154-01	LATCH BRACKET
20	2	900044-7	SOCKET SCREW, 1/4"-20 X 1-1/4" LG.
21	2	900035-7	CAP SCREW, 1/2"-13 X 2-1/2" LG.
22	1	281673-01	STOP BLOCK
23	2	902000-16	FLAT WASHER, 5/8"
24	4	900014-6	CAP SCREW, 3/8"-16 X 1-1/2" LG, GRADE 8
25	4	902000-10	FLAT WASHER, 3/8"
26	4	901016-4	LOCK NUT, 3/8"-16
27	1	282277-01	OPENER PIN
28	1	092046-10	BUSHING
29	1	902000-20	FLAT WASHER, 3/4"
30	1	905033-2	ROLL PIN, 1/4" X 1-1/4"
31	1	282272-01	OPENER TORSION SPRING
32	1	900035-12	CAP SCREW, 1/2"-13 X 4-1/2"

# PARTS BREAKDOWN

## MAIN ASSEMBLY: GPTLR-25 & GPTLR-33 (STEEL PLATFORM & RAMP OPTION)

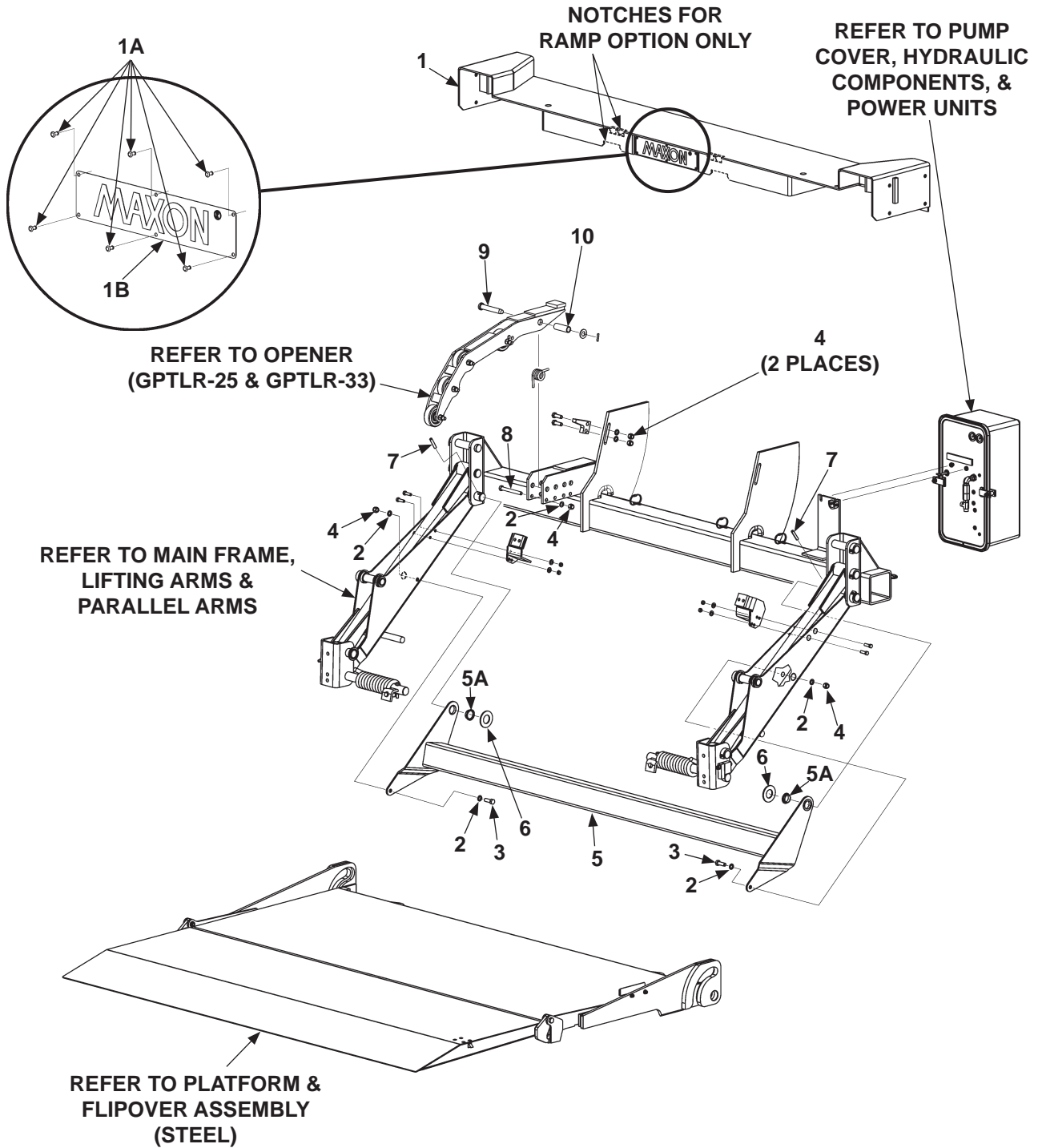

**MAXON®**

11921 Slauson Ave. Santa Fe Springs, CA. 90670 (800) 227-4116 FAX (888) 771-7713

ITEM	QTY.	PART NO.	DESCRIPTION
<b>1</b>	1	281090-01	EXTENSION PLATE ASSEMBLY (96" WIDE)
		281090-02	EXTENSION PLATE ASSEMBLY (102" WIDE)
		281484-01	EXTENSION PLATE ASSEMBLY (96" WIDE RAMP OPTION)
		281484-02	EXTENSION PLATE ASSEMBLY (102" WIDE RAMP OPTION)
<b>1A</b>	6	207644	RIVET, 3/16" X .40" GRIP
<b>1B</b>	1	050175	MAXON PLATE
<b>2</b>	5	902000-14	FLAT WASHER, 1/2"
<b>3</b>	2	900035-3	CAP SCREW, 1/2"-13 X 1-1/2" LG.
<b>4</b>	3	901010	LOCK NUT, 1/2"-13
<b>5</b>	1	281580-01	ICC BUMPER (96" WIDE)
		281580-02	ICC BUMPER (102" WIDE)
<b>5A</b>	2	908088-01	BEARING, FLANGED
<b>6</b>	2	902013-21	FLAT WASHER, 1-3/8"
<b>7</b>	2	221416	ROLL PIN, 3/8" X 2" LG.
<b>8</b>	1	900035-12	CAP SCREW, 1/2"-13 X 4-1/2"
<b>9</b>	1	282277-01	OPENER PIN
<b>10</b>	1	092046-10	BUSHING

**MAXON**<sup>®</sup>

11921 Slauson Ave. Santa Fe Springs, CA. 90670 (800) 227-4116 FAX (888) 771-7713

# PARTS BREAKDOWN

## MAIN ASSEMBLY: GPTLR-25 & GPTLR-33 (STEEL PLATFORM & RAMP OPTION) - Continued

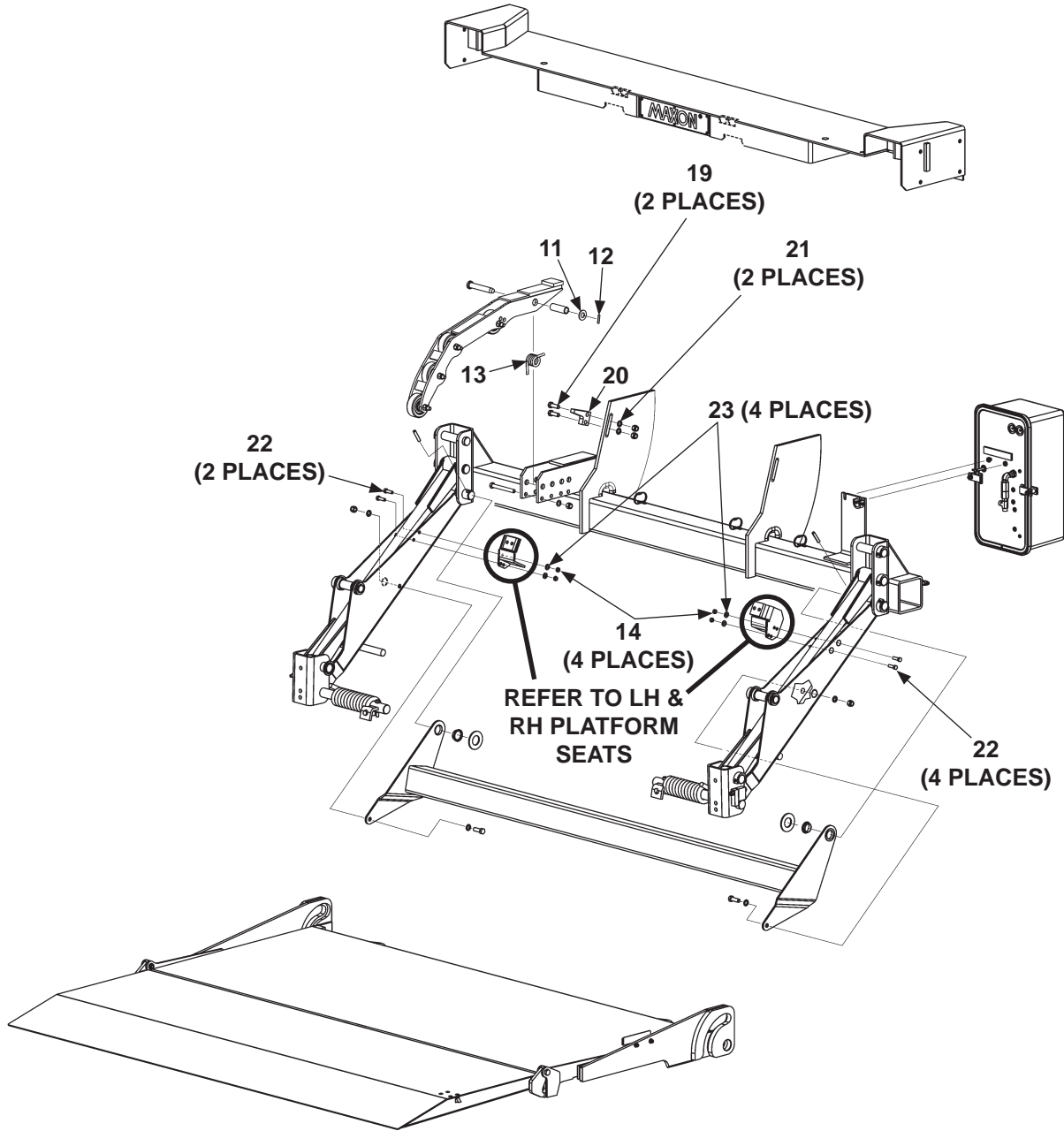

ITEM	QTY.	PART NO.	DESCRIPTION
11	1	902000-20	FLAT WASHER, 3/4"
12	1	905033-2	ROLL PIN, 1/4" X 1-1/4"
13	1	282272-01	OPENER TORSION SPRING
14	4	901016-4	LOCK NUT, 3/8"-16
15	2	902013-09	FLAT WASHER, 1/4"
16	2	901000	LOCK NUT, 1/4"-20
17	1	281415-01	LATCH BRACKET
18	2	900044-7	SOCKET SCREW, 1/4"-20 X 1-1/4" LG.
19	2	900035-7	CAP SCREW, 1/2"-13 X 2-1/2" LG.
20	1	281673-01	STOP BLOCK
21	2	902000-16	FLAT WASHER, 5/8"
22	4	900014-5	CAP SCREW, 3/8"-16 X 1-1/4" LG, GRADE 8
23	4	902000-10	FLAT WASHER, 3/8"

# PARTS BREAKDOWN

## MAIN FRAME, LIFTING ARMS, & PARALLEL ARMS: GPTLR-25 & GPTLR-33

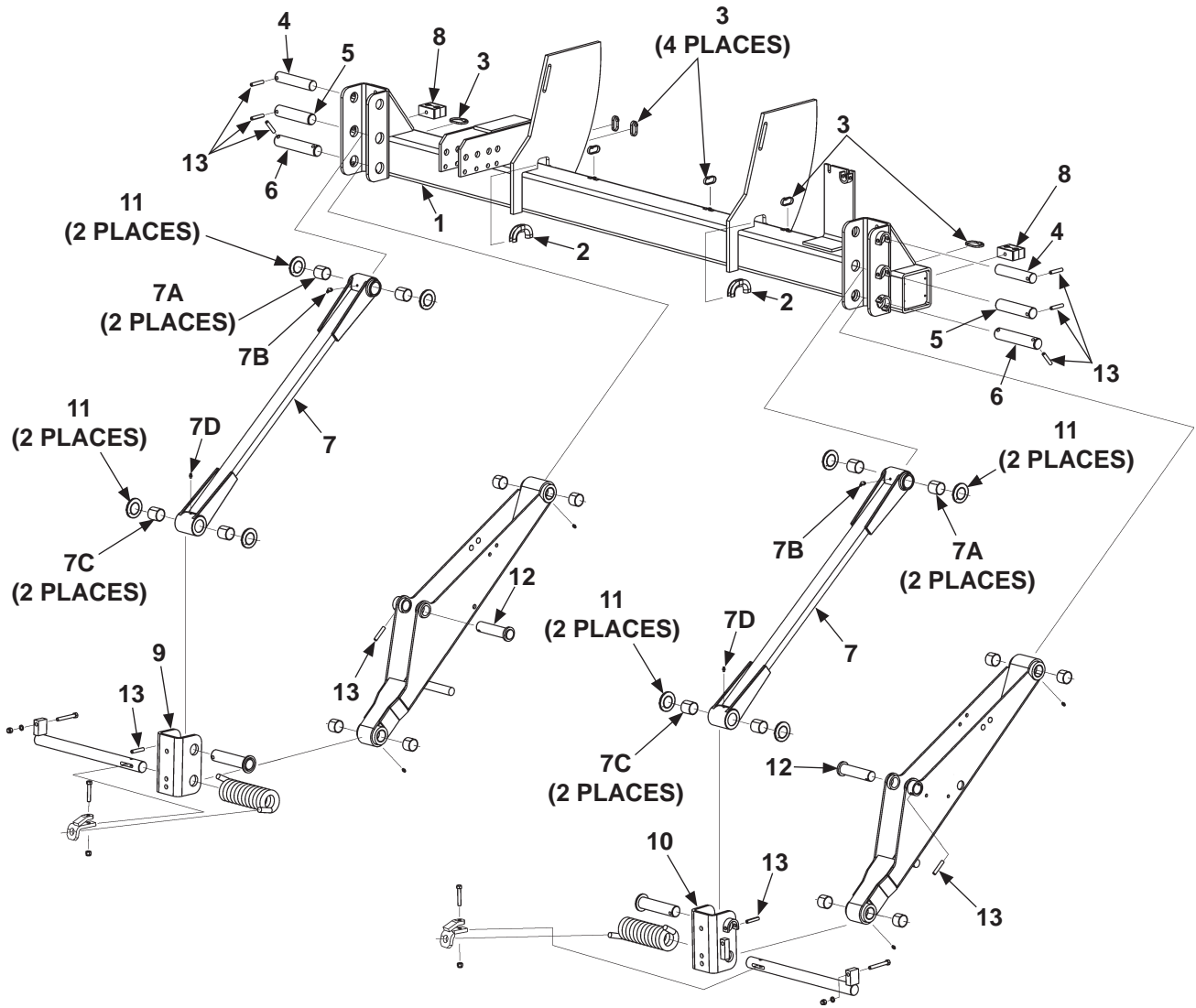

**MAXON**

11921 Slauson Ave. Santa Fe Springs, CA. 90670 (800) 227-4116 FAX (888) 771-7713

ITEM	QTY.	PART NO.	DESCRIPTION
1	1	280910-01	MAIN FRAME (96" WIDE GPTLR-25/33)
		280910-02	MAIN FRAME (102" WIDE GPTLR-25/33)
2	2	040103-5	SPLIT LOOM, 1/2" X 5" LG.
3	7	905322-01	PLASTIC TIE, 8" LG.
4	2	280969-02	PIN, 1-1/4" DIA X 5-13/16" LG.
5	2	280968-01	PIN, 1-3/8" DIA X 5-7/8" LG.
6	2	281005-01	PIN, 7" LG.
7	2	282435-01	PARALLEL ARMS
7A	4	905112-04	BEARING, SELF-LUBE, 1-1/2" LG.
7B	1	906796-01	45° LUBE FITTING
7C	4	905112-03	BEARING, SELF-LUBE, 1-3/8" LG.
7D	1	224342	LUBE FITTING
8	2	262415	DUAL TUBE CLAMP
9	1	280971-02	SHACKLE, LH
10	1	280971-01	SHACKLE, RH
11	8	908059-01	BEARING, THRUST
12	2	281127-01	PIN, CYLINDER
13	10	904717-08	ROLL PIN, 3/8" X 2-1/2" LG.

**MAXON®**

11921 Slauson Ave. Santa Fe Springs, CA. 90670 (800) 227-4116 FAX (888) 771-7713

# PARTS BREAKDOWN

## MAIN FRAME, LIFTING ARMS, & PARALLEL ARMS: GPTLR-25 & GPTLR-33 - Continued

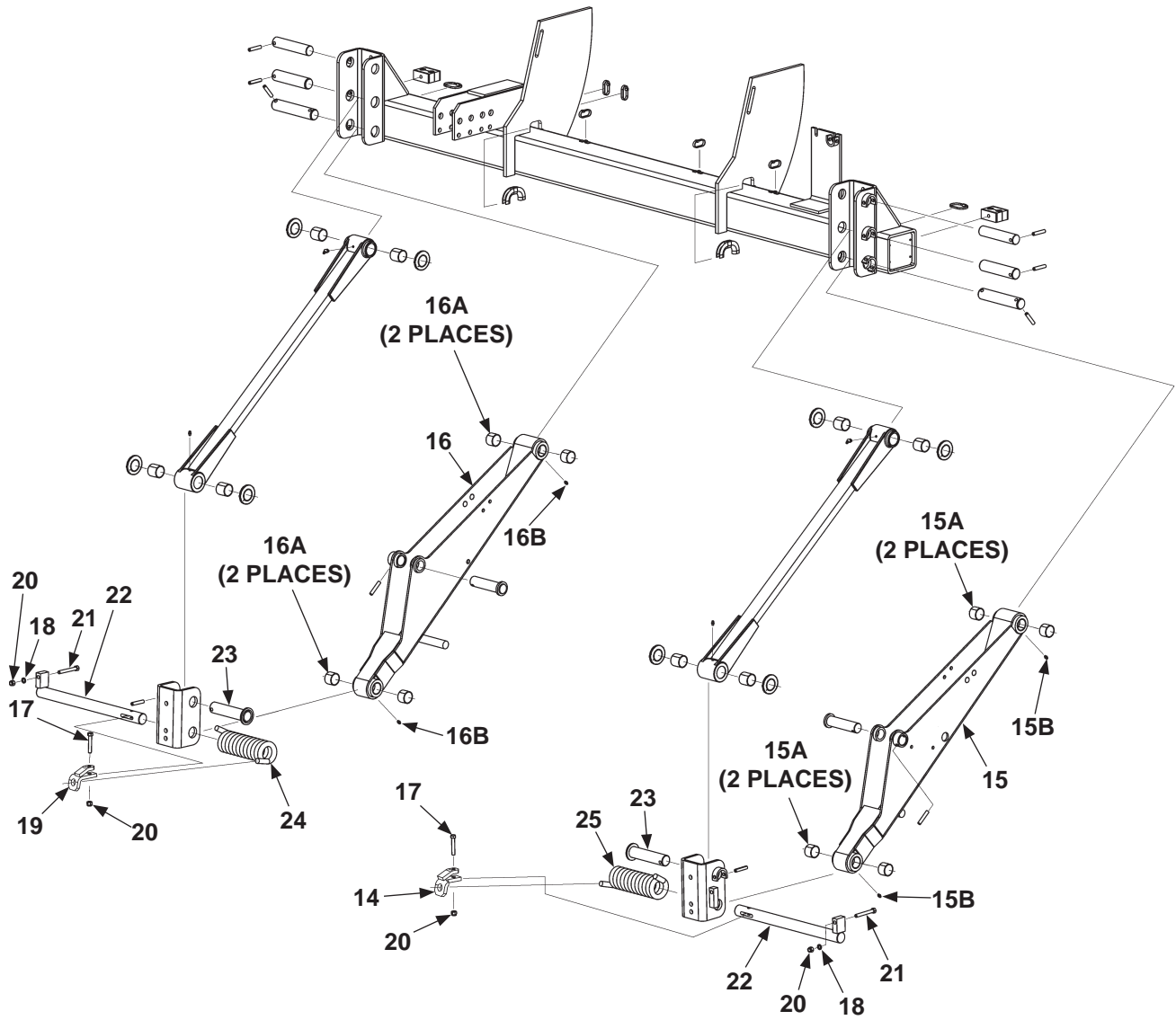



ITEM	QTY.	PART NO.	DESCRIPTION
14	1	281515-01	BRACKET, REINFORCEMENT, RH
15	1	282440-01	LIFT ARM, RH
15A	4	908047-02	BEARING, SELF-LUBE
15B	2	224342	LUBE FITTING
16	1	282440-02	LIFT ARM, LH
16A	4	908047-02	BEARING, SELF-LUBE
16B	2	224342	LUBE FITTING
17	2	900014-10	CAP SCREW, 3/8"-16 X 2-1/2" LG, GRADE 8
18	2	902000-10	FLAT WASHER, 3/8"
19	1	281515-02	BRACKET, REINFORCEMENT, LH
20	4	901002	LOCK NUT, 3/8"-16
21	2	900014-11	CAP SCREW, 3/8"-16 X 3" LG.
22	2	281004-01	PIN, SPRING
23	2	280976-01	PIN, 6" LG.
24	1	280950-02	TORSION SPRING, LH (ALUMINUM PLATFORM)
		281319-02	TORSION SPRING, LH (STEEL PLATFORM)
25	1	280950-01	TORSION SPRING, RH (ALUMINUM PLATFORM)
		281319-01	TORSION SPRING, RH (STEEL PLATFORM)

# PARTS BREAKDOWN

## MAIN FRAME, LIFTING ARMS, & PARALLEL ARMS: GPTLR-44 & GPTLR-55

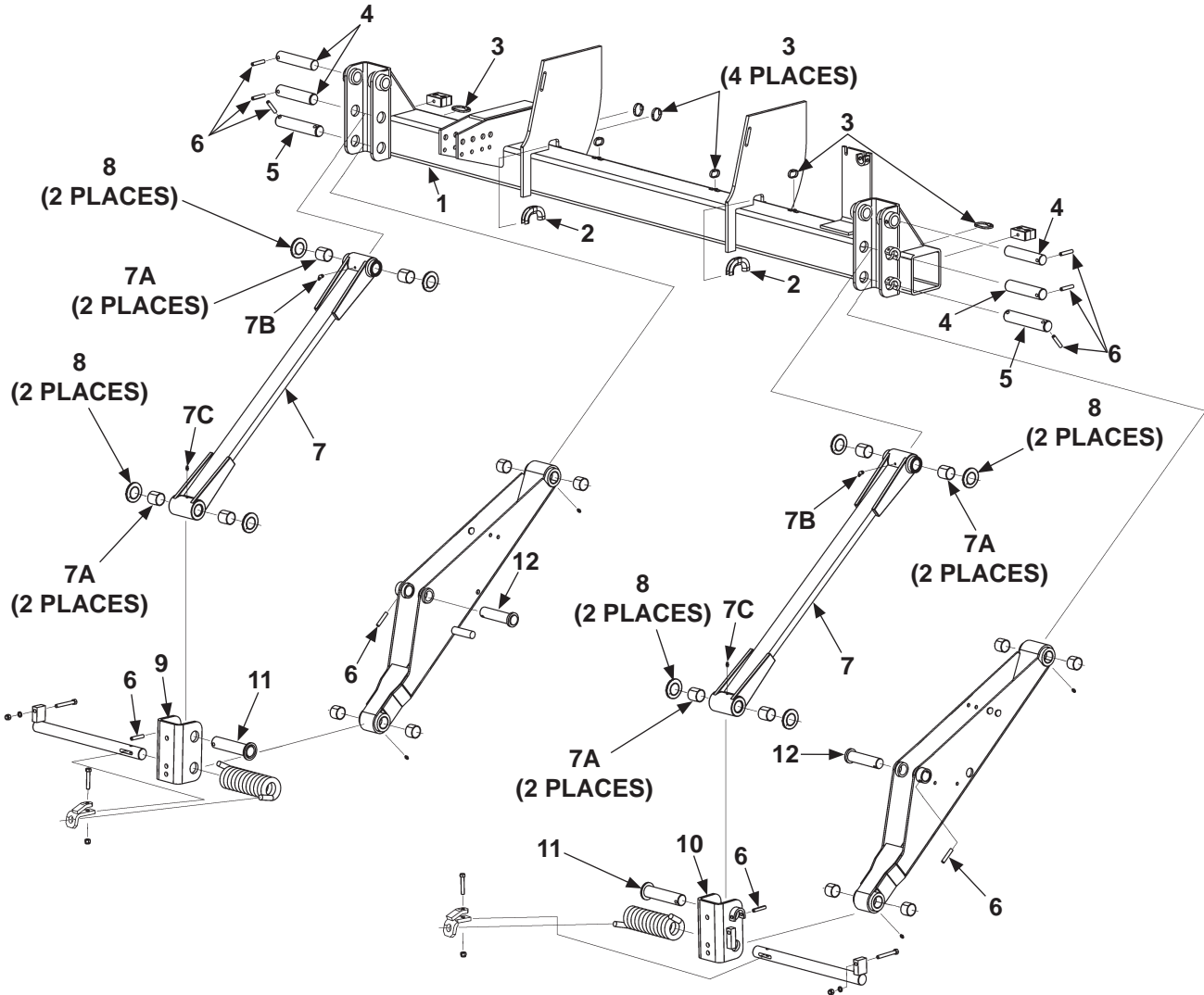

**MAXON**

11921 Slauson Ave. Santa Fe Springs, CA. 90670 (800) 227-4116 FAX (888) 771-7713

ITEM	QTY.	PART NO.	DESCRIPTION
1	1	282545-01	MAIN FRAME (96" WIDE GPTLR-44/55)
		282545-02	MAIN FRAME (102" WIDE GPTLR-44/55)
2	2	040103-5	SPLIT LOOM, 1/2" X 5" LG.
3	7	905322-01	PLASTIC TIE, 8" LG.
4	4	280968-04	PIN, 1-3/8" DIA X 7-1/8" LG.
5	2	281005-01	PIN, 8-1/16" LG.
6	10	904717-08	ROLL PIN, 3/8" X 2-1/2" LG.
7	2	282546-01	PARALLEL ARMS
7A	4	908065-04	BEARING, SELF-LUBE, 1-1/2" LG.
7B	1	906796-01	45° LUBE FITTING
7C	3	224342	LUBE FITTING
8	8	908059-01	BEARING, THRUST
9	1	281033-02	SHACKLE, LH
10	1	281033-01	SHACKLE, RH
11	2	280976-02	PIN, 7" LG.
12	2	281119-01	PIN, CYLINDER

# PARTS BREAKDOWN

## MAIN FRAME, LIFTING ARMS, & PARALLEL ARMS: GPTLR-44 & GPTLR-55 - Continued

**MAXON**<sup>®</sup>

11921 Slauson Ave. Santa Fe Springs, CA. 90670 (800) 227-4116 FAX (888) 771-7713

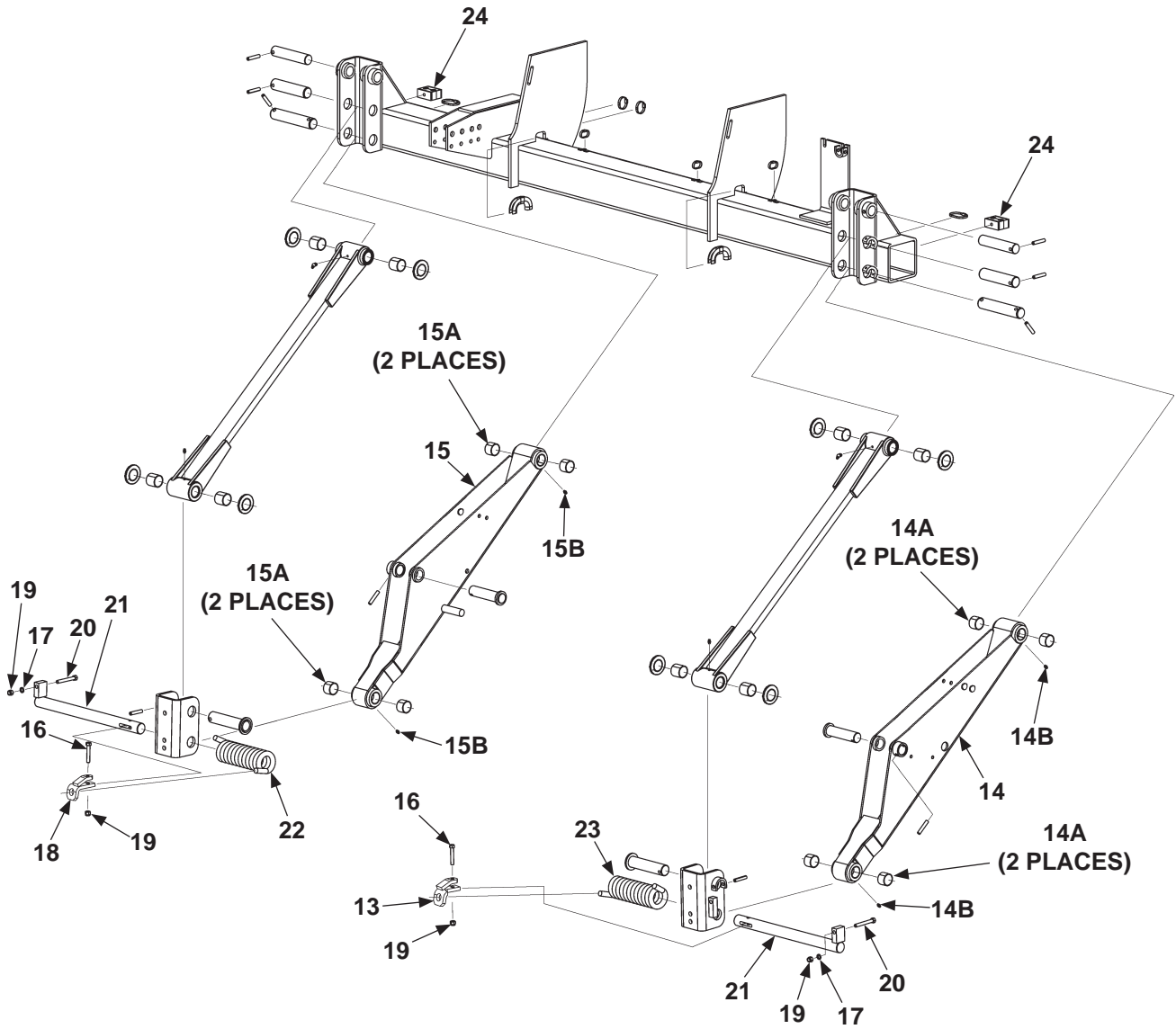

ITEM	QTY.	PART NO.	DESCRIPTION
13	1	281515-01	BRACKET, REINFORCEMENT, RH
14	1	282543-01	LIFT ARM, RH
14A	4	908047-02	BEARING, SELF-LUBE
14B	2	224342	LUBE FITTING
15	1	282543-02	LIFT ARM, LH
15A	4	908047-02	BEARING, SELF-LUBE
15B	2	224342	LUBE FITTING
16	2	900014-10	CAP SCREW, 3/8"-16 X 2-1/2" LG, GRADE 8
17	6	902000-10	FLAT WASHER, 3/8"
18	1	281515-02	BRACKET, REINFORCEMENT, LH
19	4	901002	LOCK NUT, 3/8"-16
20	2	900014-11	CAP SCREW, 3/8"-16 X 3" LG.
21	2	281053-01	PIN, SPRING
22	1	280950-02	TORSION SPRING, LH (ALUMINUM PLATFORM)
23	1	280950-01	TORSION SPRING, RH (ALUMINUM PLATFORM)
24	2	262415	DUAL TUBE CLAMP

**MAXON**<sup>®</sup> 11921 Slauson Ave. Santa Fe Springs, CA. 90670 (800) 227-4116 FAX (888) 771-7713

# PARTS BREAKDOWN

## OPENER (GPTLR-25 & GPTLR-33)

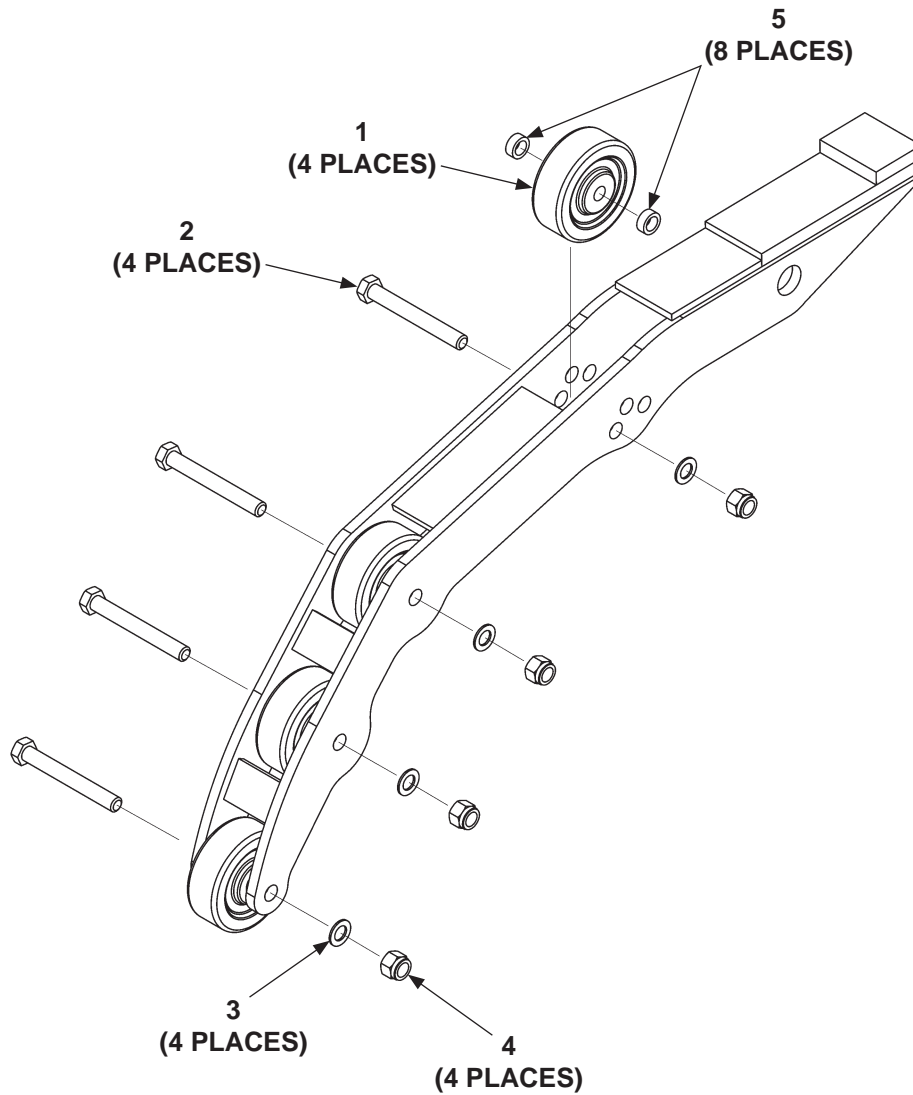

ITEM	QTY	PART NO.	DESCRIPTION
REF	1	282275-01	OPENER ASSEMBLY, GPTLR 25/33
1	4	280082-01	ROLLER, OPENER, 3-1/2" X 1-1/4" X 1/2"
2	4	900035-11	CAP SCREW, 1/2"-13 X 4" LG.
3	4	902000-14	FLAT WASHER, 1/2"
4	4	901010	LOCK NUT, 1/2"-13
5	8	092028-10	SPACER

**MAXON®**

11921 Slauson Ave. Santa Fe Springs, CA. 90670 (800) 227-4116 FAX (888) 771-7713

## OPENER (GPTLR-44 & GPTLR-55)

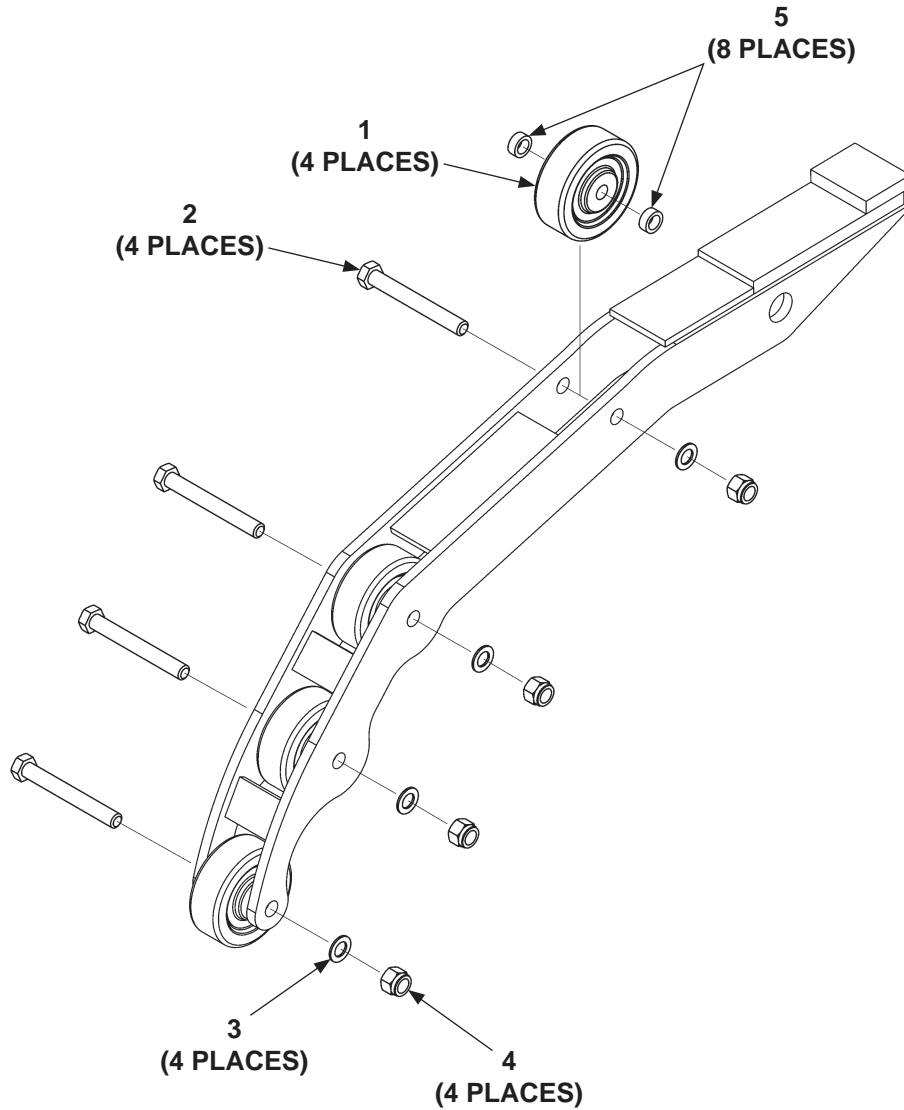

ITEM	QTY	PART NO.	DESCRIPTION
REF	1	282505-01	OPENER ASSEMBLY, GPTLR 44/55
1	4	280082-01	OPENER ROLLER, 3-1/2" X 1-1/4" X 1/2"
2	4	900035-11	CAP SCREW, 1/2"-13 X 4" LG.
3	4	902000-14	FLAT WASHER, 1/2"
4	4	901010	LOCK NUT, 1/2"-13
5	8	092028-10	SPACER

# PARTS BREAKDOWN

## LH & RH PLATFORM SEATS: GPTLR-25 & GPTLR-33 (ALUMINUM PLATFORM WITH FIXED RAMP OR CART STOPS ONLY)

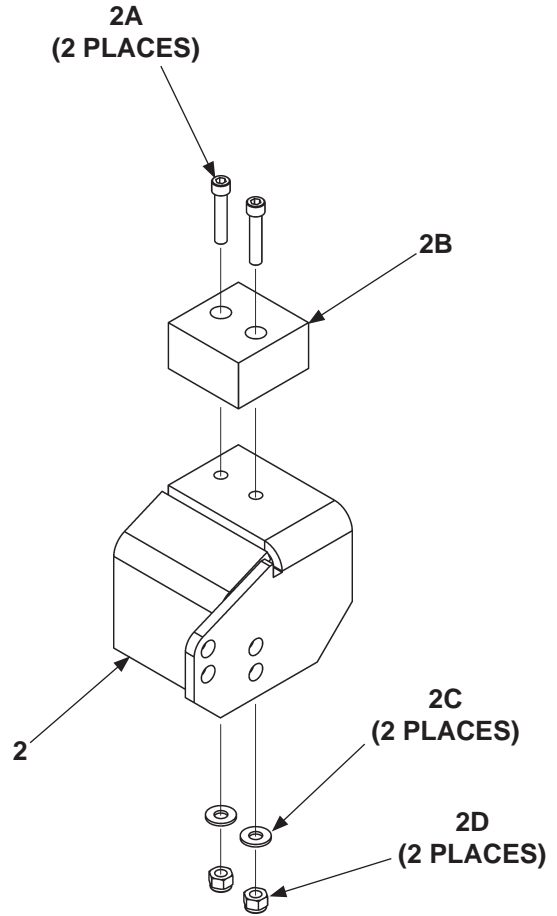
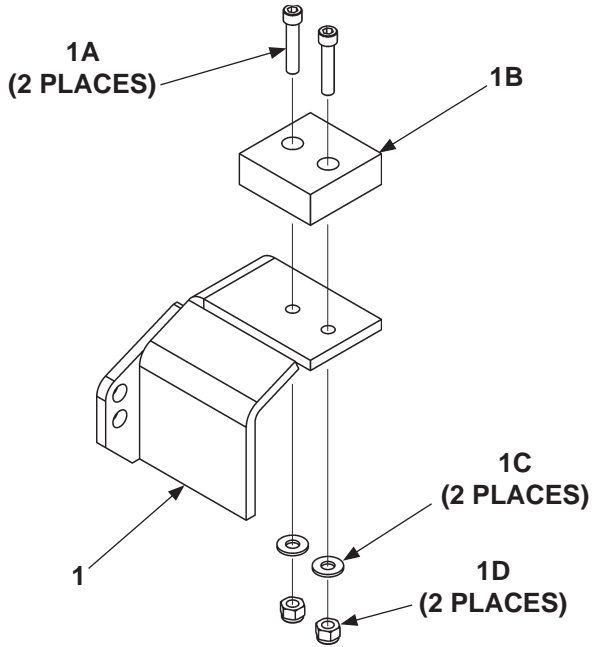

ITEM	QTY.	PART NO.	DESCRIPTION
1	1	281650-02	PLATFORM SEAT, LH (1/2" THICK PAD)
1A	2	900025-1	SOCKET SCREW, 1/4"-20 X 1" LG.
1B	1	281649-01	PLASTIC PAD (1/2" THICK PAD)
1C	2	902013-09	FLAT WASHER, 1/4"
1D	2	901000	LOCK NUT, 1/4"-20
2	1	281653-01	PLATFORM SEAT, RH (3/4" THICK PAD)
2A	2	900025-5	SOCKET SCREW, 1/4"-20 X 1-1/4" LG.
2B	1	281652-01	PLASTIC PAD (3/4" THICK PAD)
2C	2	902013-09	FLAT WASHER, 1/4"
2D	2	901000	LOCK NUT, 1/4"-20

**MAXON®**

11921 Slauson Ave. Santa Fe Springs, CA. 90670 (800) 227-4116 FAX (888) 771-7713



## LH & RH PLATFORM SEATS: GPTLR-25 & GPTLR-33 (ALUMINUM PLATFORM WITH RETENTION RAMP ONLY)

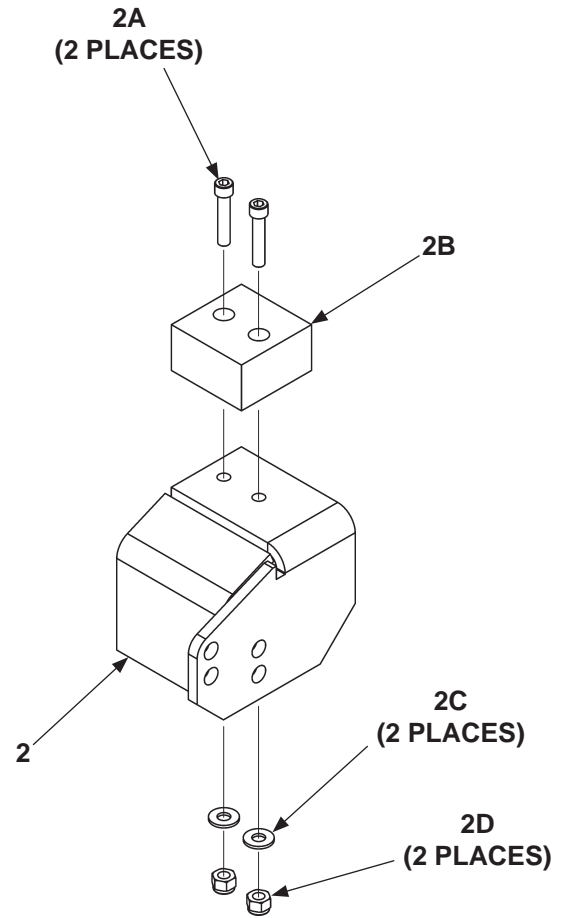
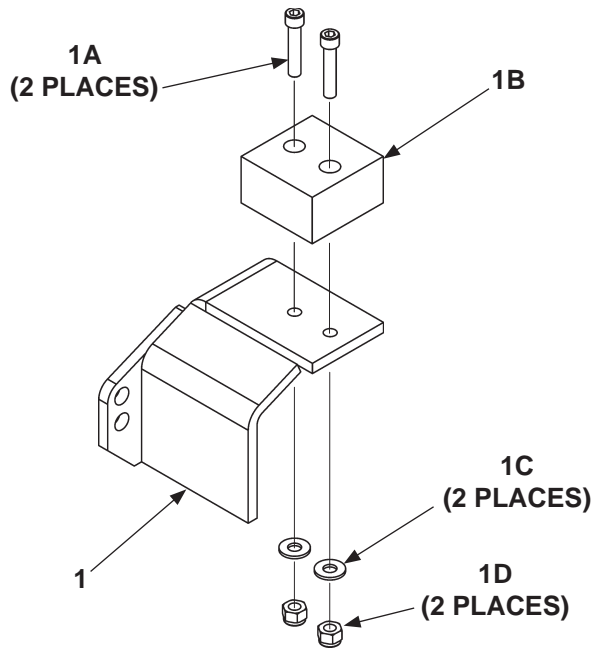

ITEM	QTY.	PART NO.	DESCRIPTION
1	1	281653-02	PLATFORM SEAT, LH (3/4" THICK PAD)
1A	2	900025-5	SOCKET SCREW, 1/4"-20 X 1-1/4" LG.
1B	1	281652-01	PLASTIC PAD (3/4" THICK PAD)
1C	2	902013-09	FLAT WASHER, 1/4"
1D	2	901000	LOCK NUT, 1/4"-20
2	1	281653-01	PLATFORM SEAT, RH (3/4" THICK PAD)
2A	2	900025-5	SOCKET SCREW, 1/4"-20 X 1-1/4" LG.
2B	1	281652-01	PLASTIC PAD (3/4" THICK PAD)
2C	2	902013-09	FLAT WASHER, 1/4"
2D	2	901000	LOCK NUT, 1/4"-20

**MAXON**<sup>®</sup>

11921 Slauson Ave. Santa Fe Springs, CA. 90670 (800) 227-4116 FAX (888) 771-7713

# PARTS BREAKDOWN

## LH & RH PLATFORM SEATS: GPTLR-25 & GPTLR-33

(STEEL PLATFORM ONLY)

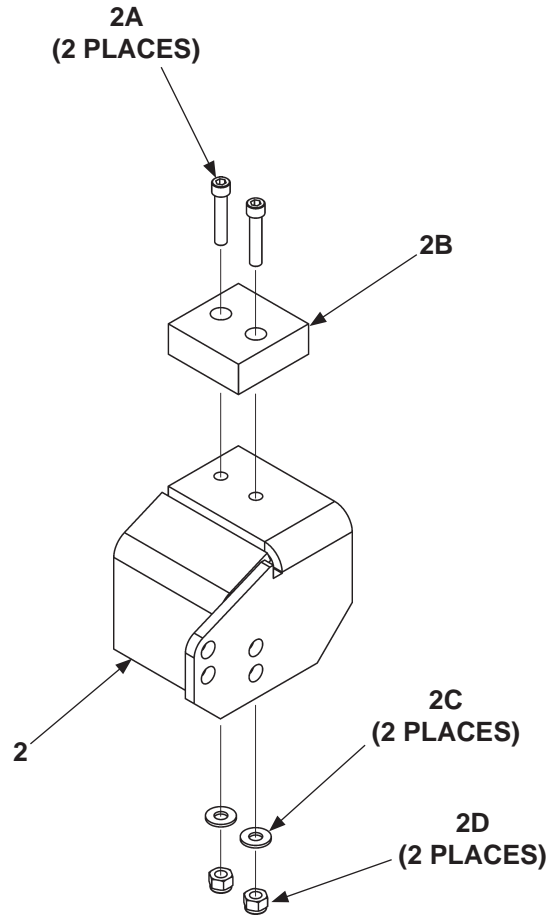
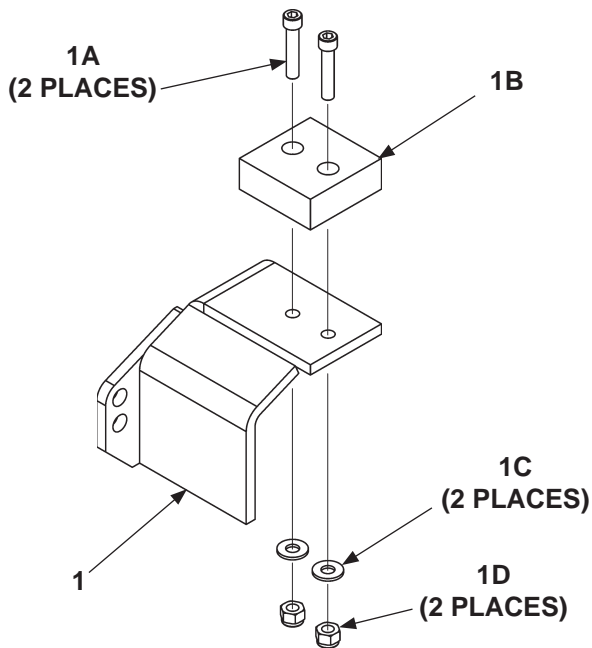

ITEM	QTY.	PART NO.	DESCRIPTION
1	1	281650-02	PLATFORM SEAT, LH (1/2" THICK PAD)
1A	2	900025-1	SOCKET SCREW, 1/4"-20 X 1" LG.
1B	1	281649-01	PLASTIC PAD (1/2" THICK PAD)
1C	2	902013-09	FLAT WASHER, 1/4"
1D	2	901000	LOCK NUT, 1/4"-20
2	1	281650-01	PLATFORM SEAT, RH (1/2" THICK PAD)
2A	2	900025-1	SOCKET SCREW, 1/4"-20 X 1" LG.
2B	1	281649-01	PLASTIC PAD (1/2" THICK PAD)
2C	2	902013-09	FLAT WASHER, 1/4"
2D	2	901000	LOCK NUT, 1/4"-20

## LH & RH PLATFORM SEATS: GPTLR-44 & GPTLR-55 (ONLY ALUMINUM PLATFORM WITH FIXED RAMP OR CART STOPS)

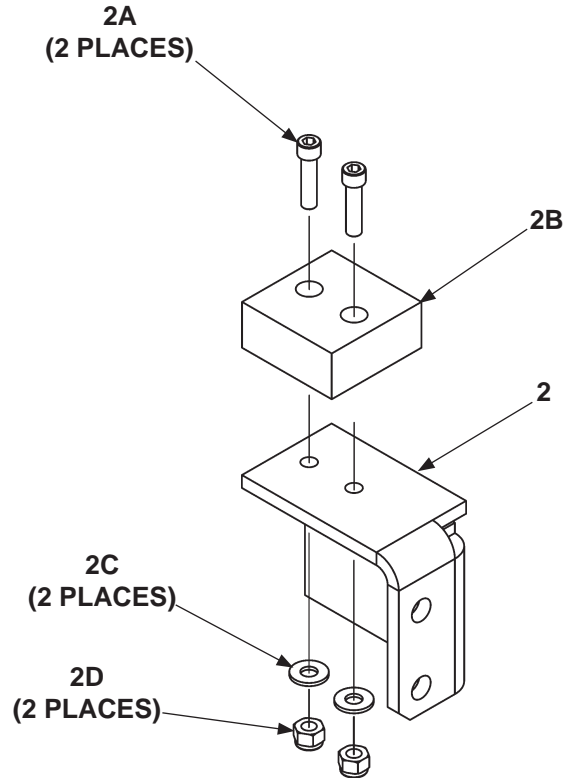
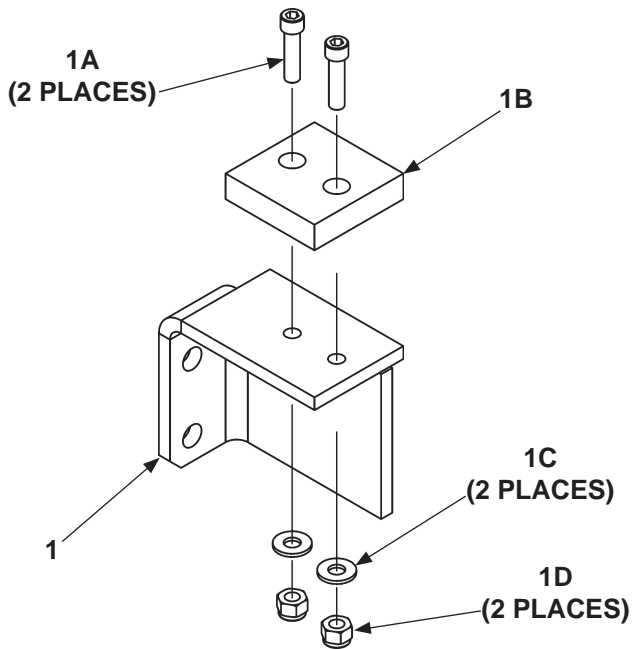

ITEM	QTY.	PART NO.	DESCRIPTION
1	1	281698-02	PLATFORM SEAT, LH (1/2" THICK PAD)
1A	2	900025-1	SOCKET SCREW, 1/4"-20 X 1" LG.
1B	1	281649-01	PLASTIC PAD (1/2" THICK PAD)
1C	2	902013-09	FLAT WASHER, 1/4"
1D	2	901000	LOCK NUT, 1/4"-20
2	1	281716-01	PLATFORM SEAT, RH (3/4" THICK PAD)
2A	2	900025-5	SOCKET SCREW, 1/4"-20 X 1-1/4" LG.
2B	1	281652-01	PLASTIC PAD (3/4" THICK PAD)
2C	2	902013-09	FLAT WASHER, 1/4"
2D	2	901000	LOCK NUT, 1/4"-20

**MAXON**<sup>®</sup>

11921 Slauson Ave. Santa Fe Springs, CA. 90670 (800) 227-4116 FAX (888) 771-7713

# PARTS BREAKDOWN

## LH & RH PLATFORM SEATS: GPTLR-44 & GPTLR-55

(ONLY PLATFORM WITH RETENTION RAMP)

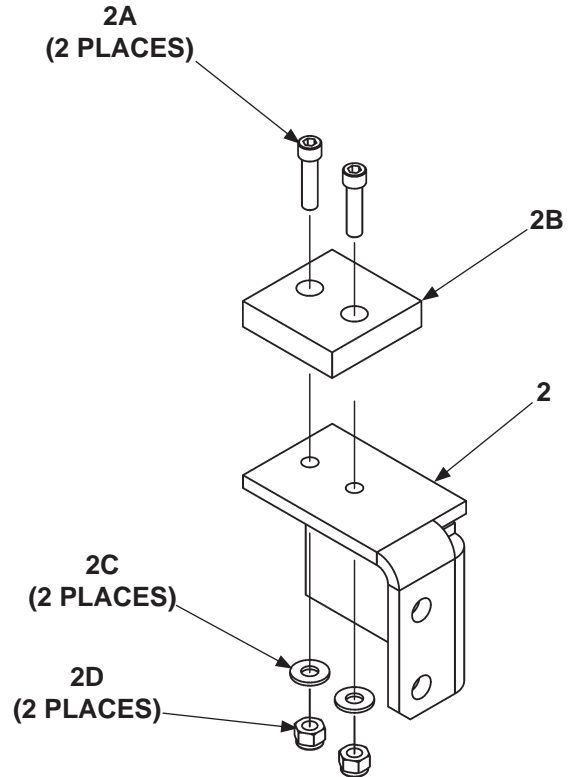
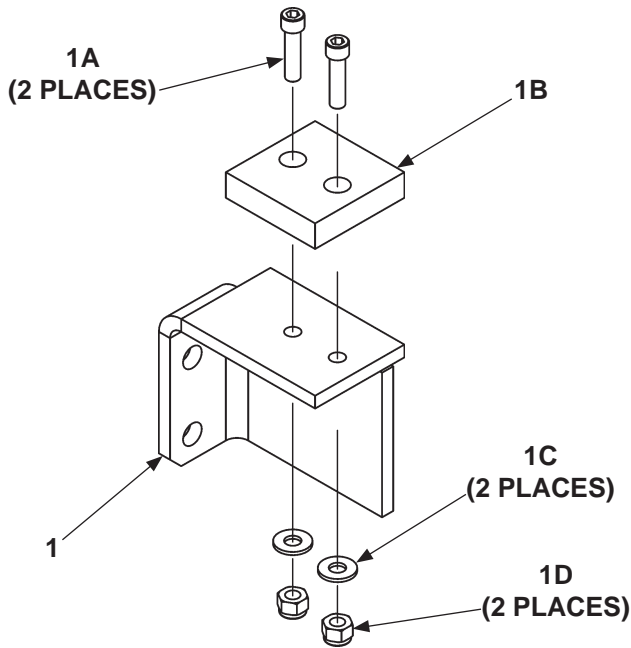

ITEM	QTY.	PART NO.	DESCRIPTION
1	1	281698-02	PLATFORM SEAT, LH (1/2" THICK PAD)
1A	2	900025-1	SOCKET SCREW, 1/4"-20 X 1" LG.
1B	1	281649-01	PLASTIC PAD (1/2" THICK PAD)
1C	2	902013-09	FLAT WASHER, 1/4"
1D	2	901000	LOCK NUT, 1/4"-20
2	1	281698-01	PLATFORM SEAT, RH (1/2" THICK PAD)
2A	2	900025-1	SOCKET SCREW, 1/4"-20 X 1" LG.
2B	1	281649-01	PLASTIC PAD (1/2" THICK PAD)
2C	2	902013-09	FLAT WASHER, 1/4"
2D	2	901000	LOCK NUT, 1/4"-20

THIS PAGE INTENTIONALLY LEFT BLANK

# PARTS BREAKDOWN PLATFORM & FLIPOVER ASSEMBLY (ALUMINUM)

**MAXON®**

11921 Slauson Ave. Santa Fe Springs, CA. 90670 (800) 227-4116 FAX (888) 771-7713

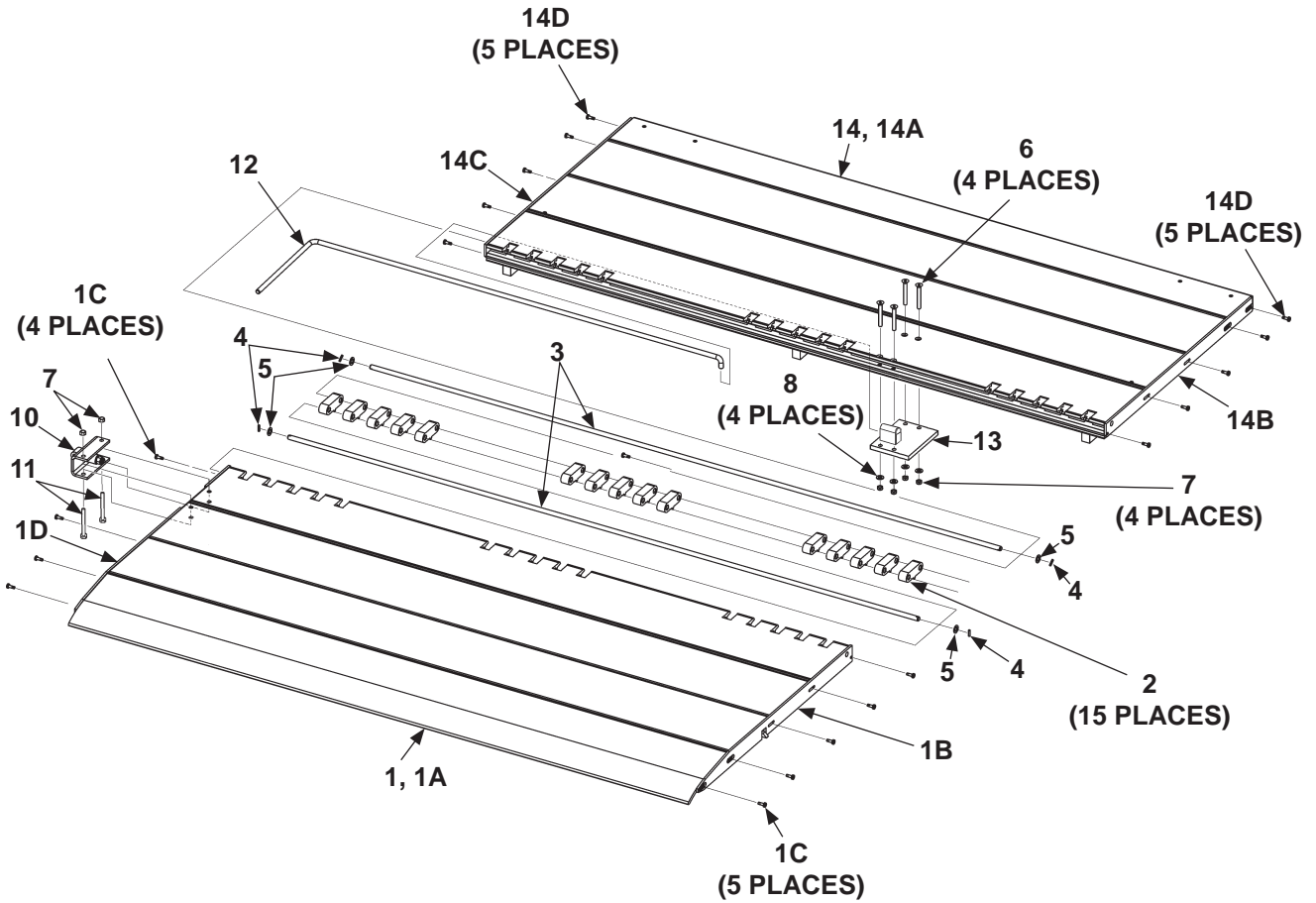

ITEM	QTY.	PART NO.	DESCRIPTION
1	1	282515-01	FLIPOVER ASSEMBLY, 79-1/2" (WIDE)
		282515-02	FLIPOVER ASSEMBLY, 85-1/2" (WIDE)
1A	1	282514-01	FLIPOVER WELDMENT, 79" (WIDE)
		282514-02	FLIPOVER WELDMENT, 85" (WIDE)
1B	1	281635-01	SIDE PLATE, FLIPOVER RH
1C	9	900705-01	SELF-TAPPING SCREW, 1/4"-20 X 1" LG.
1D	1	281636-01	SIDE PLATE, FLIPOVER LH
2	15	281010-01	HINGE ASSEMBLY
3	2	263456-12	HINGE, ROD, 80" LG. (79-1/2" WIDE PLATFORM)
		263456-13	HINGE, ROD, 86" LG. (85-1/2" WIDE PLATFORM)
4	4	905015-1	ROLL PIN, 3/16" X 3/4" LG.
5	4	902000-14	FLAT WASHER, 1/2"
6	4	900040-11	FLAT HEAD SOCKET SCREW, 3/8"-16 X 3" LG, GRADE 8
7	6	901016-4	LOCK NUT, THIN HEAD, 3/8"-16, GRADE 8
8	4	902013-11	FLAT WASHER, 3/8"
9	2	901002	LOCK NUT, 3/8"-16, GRADE 8
10	1	281135-01	TORSION BAR BRACKET
11	2	900014-20	CAP SCREW, 3/8"-16 X 3-1/4" LG, GRADE 8
12	1	281141-01	TORSION BAR
13	1	281410-01	TORSION BAR HOLDER
14	1	281330-01	PLATFORM ASSEMBLY, 79-1/2" (WIDE)
		281330-02	PLATFORM ASSEMBLY, 85-1/2" (WIDE)
14A	1	281144-01	PLATFORM WELDMENT, 79" (WIDE)
		281144-02	PLATFORM WELDMENT, 85" (WIDE)
14B	1	280987-01	SIDE PLATE, RH, PLATFORM
14C	1	281143-01	SIDE PLATE, LH, PLATFORM
14D	10	900705-01	SELF-TAPPING SCREW, 1/4"-20 X 1" LG.

# PARTS BREAKDOWN

## PLATFORM & FLIPOVER ASSEMBLY WITH CART STOPS

(ALUMINUM)

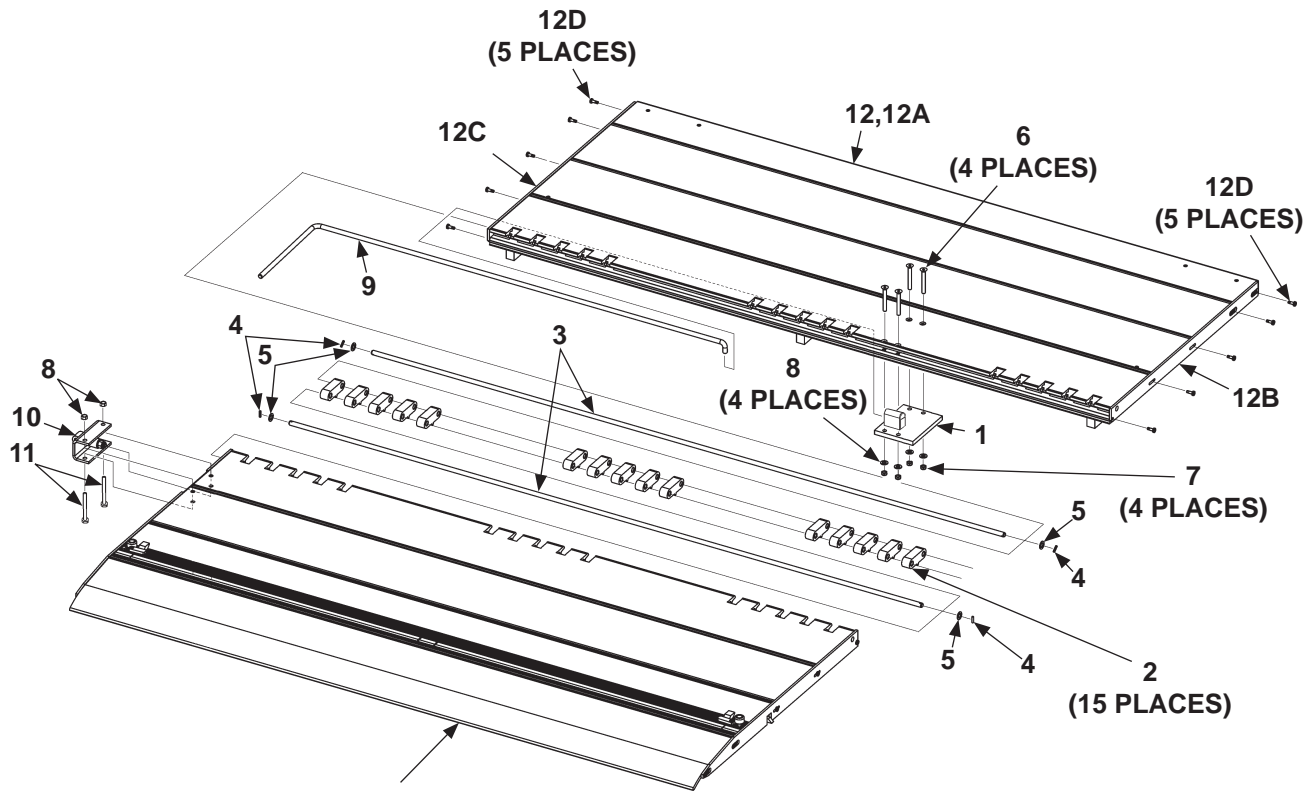

REFER TO FLIPOVER WITH SINGLE  
CART STOP OR FLIPOVER WITH DUAL  
CART STOPS (SINGLE IS SHOWN)



ITEM	QTY.	PART NO.	DESCRIPTION
1	1	281410-01	TORSION BAR HOLDER
2	15	281010-01	HINGE ASSEMBLY
3	2	263456-12	HINGE, ROD, 80" LG. (79-1/2" WIDE PLATFORM)
		263456-13	HINGE, ROD, 86" LG. (85-1/2" WIDE PLATFORM)
4	4	905015-1	ROLL PIN, 3/16" X 3/4" LG.
5	4	902000-14	FLAT WASHER, 1/2"
6	4	900040-11	FLAT HEAD SOCKET SCREW, 3/8"-16 X 3" LG, GRADE 8
7	6	901016-4	LOCK NUT, THIN HEAD, 3/8"-16, GRADE 8
8	6	902013-11	FLAT WASHER, 3/8"
9	1	281141-01	TORSION BAR
10	1	281135-01	TORSION BAR BRACKET
11	2	900014-11	CAP SCREW, 3/8"-16 X 3" LG, GRADE 8
12	1	281330-01	PLATFORM ASSEMBLY, 79-1/2" (WIDE)
		281330-02	PLATFORM ASSEMBLY, 85-1/2" (WIDE)
12A	1	281144-01	PLATFORM WELDMENT, 79" (WIDE)
		281144-02	PLATFORM WELDMENT, 85" (WIDE)
12B	1	280987-01	SIDE PLATE, RH, PLATFORM
12C	1	281143-01	SIDE PLATE, LH, PLATFORM
12D	10	900705-01	SELF-TAPPING SCREW, 1/4"-20 X 1" LG.

# PARTS BREAKDOWN FLIPOVER WITH SINGLE CART STOP (ALUMINUM)

**MAXON®**

11921 Slauson Ave. Santa Fe Springs, CA. 90670 (800) 227-4116 FAX (888) 771-7713

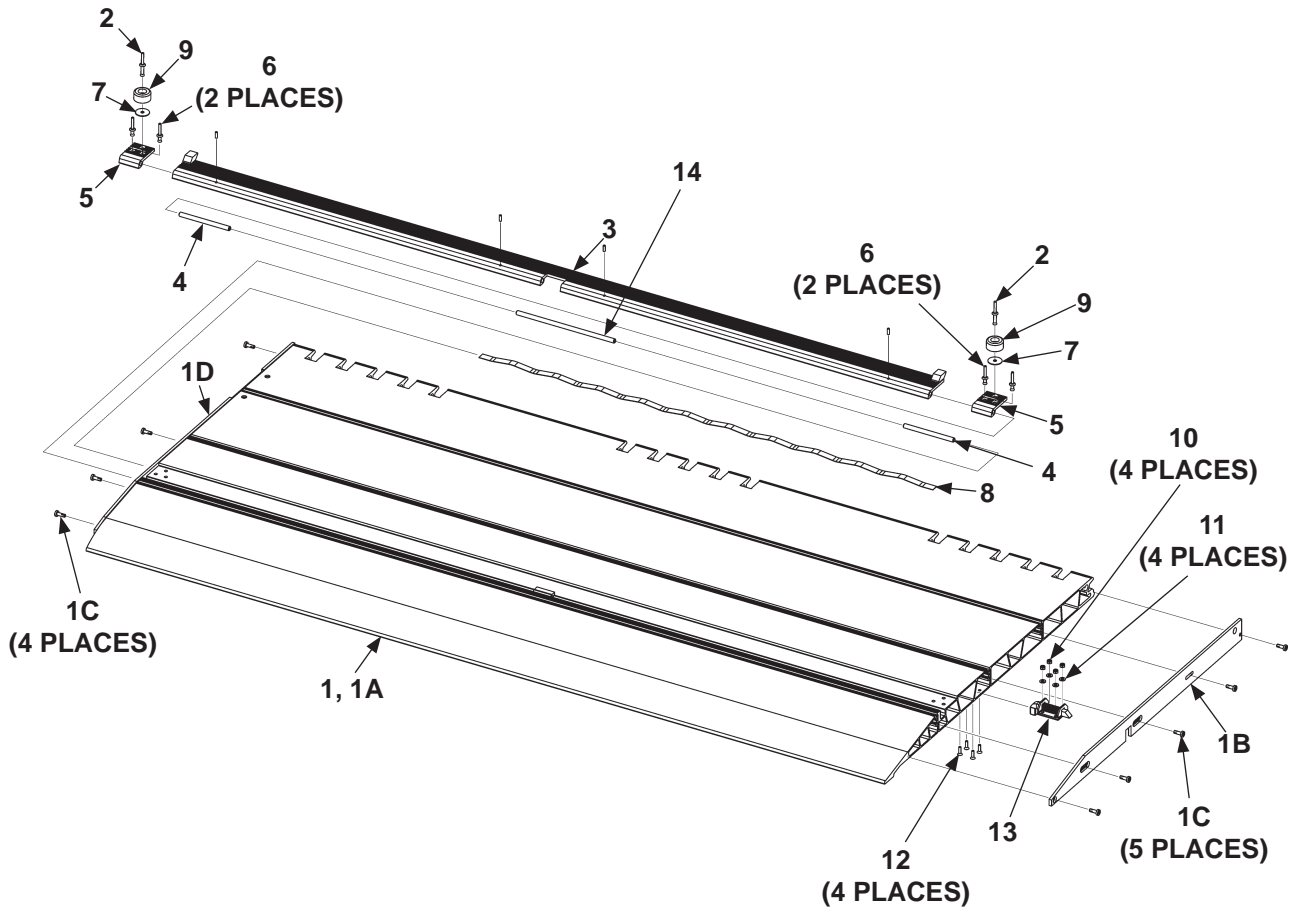

ITEM	QTY.	PART NO.	DESCRIPTION
1	1	282535-03	FLIPOVER ASSEMBLY, 79-1/2" (WIDE)
		282535-04	FLIPOVER ASSEMBLY, 85-1/2" (WIDE)
1A	1	282512-01	FLIPOVER WELDMENT, 79" (WIDE)
		282512-02	FLIPOVER WELDMENT, 85" (WIDE)
1B	1	281635-01	SIDE PLATE, FLIPOVER RH
1C	9	900705-01	SELF-TAPPING SCREW, 1/4"-20 X 1" LG.
1D	1	281636-01	SIDE PLATE, FLIPOVER LH
2	2	903705-06	RIVET, BLIND, 1/4" X 1-7/32" LG.
3	1	267092-08	CART STOP WELDMENT RH, 75" (WIDE)
		267092-09	CART STOP WELDMENT RH, 81" (WIDE)
4	2	267094-03	PIN, 5" LG.
5	2	267088-01	CART STOP LINK
6	4	903705-02	RIVET, BLIND, 1/4" X 5/8" LG.
7	2	903409-07	FENDER WASHER, 9/32" X 1-1/4" O.D.
8	1	267581-01	SPRING, FLIPOVER, 42" LG.
9	2	905314-05	BUMPER
10	4	902013-07	FLAT WASHER, #10
11	4	900028-3	SCREW, #10-24 X 3/4" LG.
12	4	901003	LOCK NUT, #10-24, GRADE 8
13	1	267201-02	SLAM LATCH, 7/16" LG.
14	1	267094-04	PIN, 9-3/4" LG.

# PARTS BREAKDOWN FLIPOVER WITH DUAL CART STOPS (ALUMINUM)

**MAXON®**

11921 Slauson Ave. Santa Fe Springs, CA. 90670 (800) 227-4116 FAX (888) 771-7713

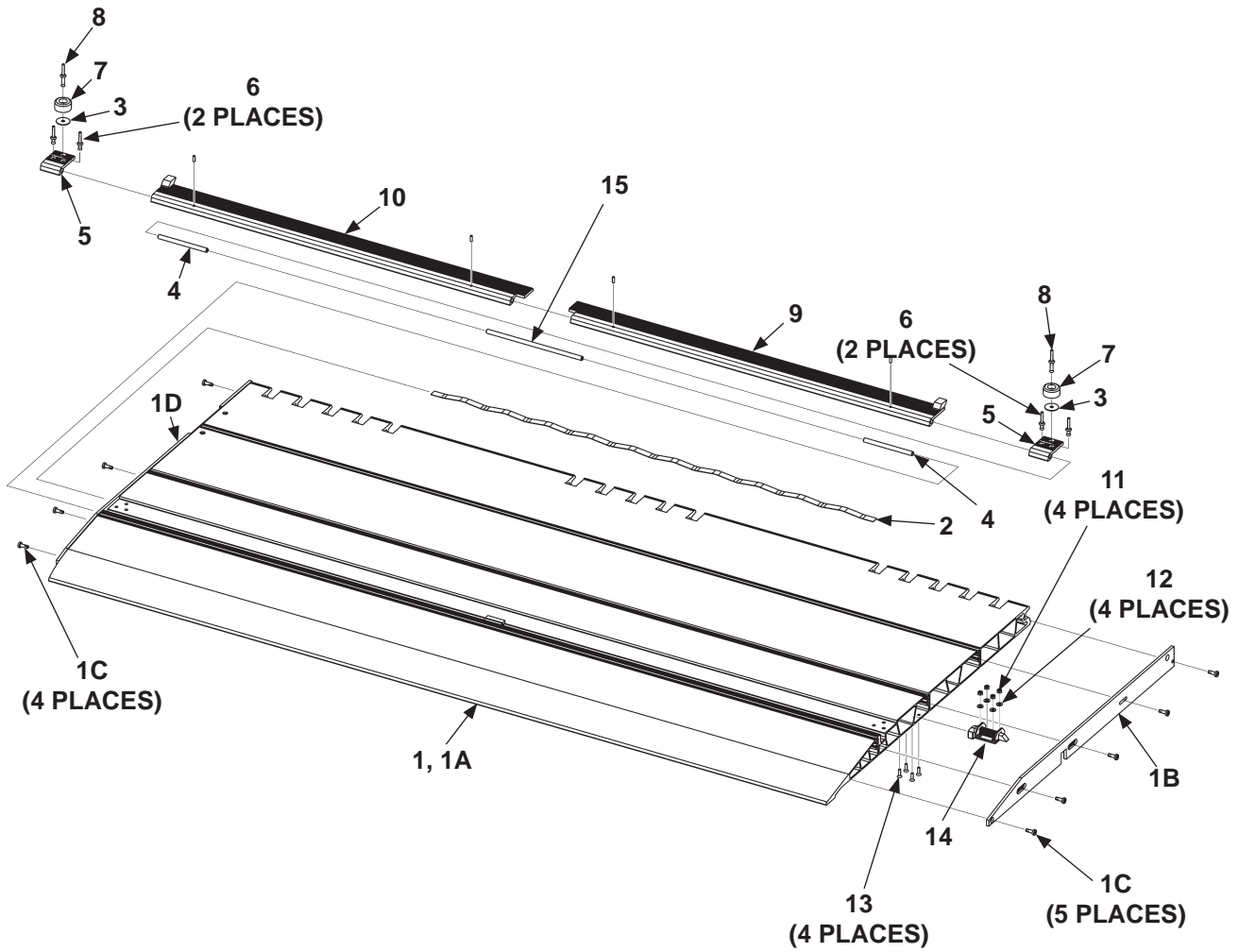

ITEM	QTY.	PART NO.	DESCRIPTION
1	1	282535-01	FLIPOVER ASSEMBLY, 79-1/2" (WIDE)
		282535-02	FLIPOVER ASSEMBLY, 85-1/2" (WIDE)
1A	1	282512-01	FLIPOVER WELDMENT, 79" (WIDE)
		282512-02	FLIPOVER WELDMENT, 85" (WIDE)
1B	1	281635-01	SIDE PLATE, FLIPOVER RH
1C	9	900705-01	SELF-TAPPING SCREW, 1/4"-20 X 1" LG.
1D	1	281636-01	SIDE PLATE, FLIPOVER LH
2	1	267581-01	SPRING, FLIPOVER, 42" LG.
3	2	903409-07	FENDER WASHER, 9/32" X 1-1/4" O.D.
4	2	267094-03	PIN, 5" LG.
5	2	267088-01	CART STOP LINK
6	2	903705-02	RIVET, BLIND, 1/4" X 5/8" LG.
7	2	905314-05	BUMPER
8	2	903705-06	RIVET, BLIND, 1/4" X 1-7/32" LG.
9	1	267092-04	CART STOP WELDMENT RH, 36-3/8" (WIDE)
		267092-06	CART STOP WELDMENT RH, 39-3/8" (WIDE)
10	1	267092-05	CART STOP WELDMENT LH, 36-3/8" (WIDE)
		267092-07	CART STOP WELDMENT LH, 39-3/8" (WIDE)
11	4	902013-07	FLAT WASHER, #10
12	4	900028-3	SCREW, #10-24 X 3/4" LG.
13	4	901003	LOCK NUT, #10-24, GRADE 8
14	1	967201-02	SLAM LATCH, 7/16" LG.
15	1	267094-04	PIN, 9-3/4" LG.

# PARTS BREAKDOWN

## PLATFORM & FLIPOVER ASSEMBLY WITH SINGLE RETENTION RAMP (ALUMINUM)

**NOTE:** This platform & flipover with retention ramp is only available for GPTLR-44 & GPTLR-55.

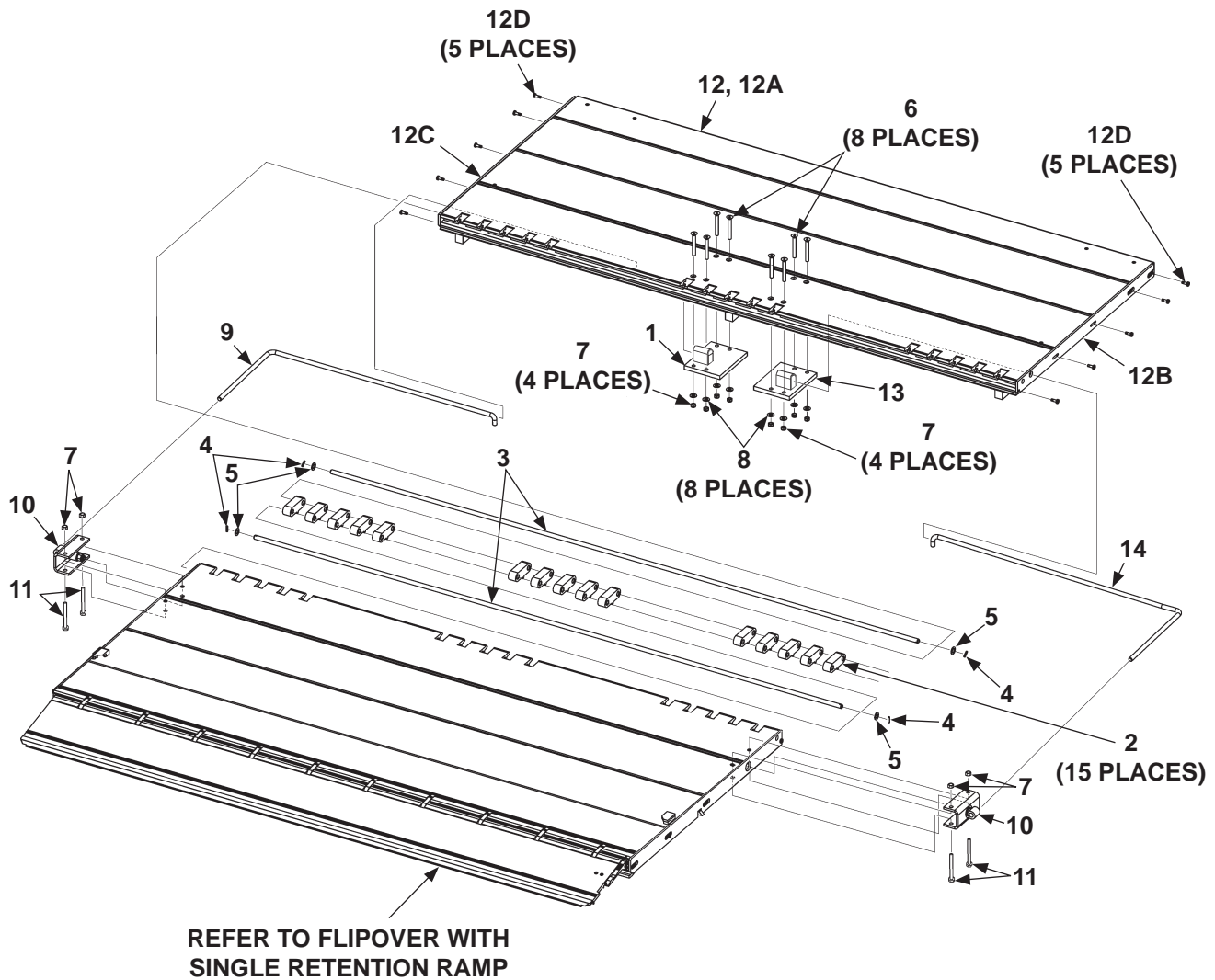

**MAXON®**

11921 Slauson Ave. Santa Fe Springs, CA. 90670 (800) 227-4116 FAX (888) 771-7713

ITEM	QTY.	PART NO.	DESCRIPTION
1	1	281410-01	TORSION BAR HOLDER, LH
2	15	281010-01	HINGE ASSEMBLY
3	2	263456-12	HINGE, ROD, 80" LG. (79-1/2" WIDE PLATFORM)
		263456-13	HINGE, ROD, 86" LG. (85-1/2" WIDE PLATFORM)
4	4	905015-1	ROLL PIN, 3/16" X 3/4" LG.
5	4	902000-14	FLAT WASHER, 1/2"
6	8	900040-11	FLAT HEAD SOCKET SCREW, 3/8"-16 X 3" LG, GRADE 8
7	12	901016-4	LOCK NUT, THIN HEAD, 3/8"-16, GRADE 8
8	8	902013-11	FLAT WASHER, 3/8"
9	1	281414-01	TORSION BAR, LH
10	2	281135-01	TORSION BAR BRACKET
11	4	900014-11	CAP SCREW, 3/8"-16 X 3" LG, GRADE 8
12	1	281330-03	PLATFORM ASSEMBLY, 79-1/2" (WIDE)
		281330-04	PLATFORM ASSEMBLY, 85-1/2" (WIDE)
12A	1	281144-03	PLATFORM WELDMENT, 79" (WIDE)
		281144-04	PLATFORM WELDMENT, 85" (WIDE)
12B	1	281143-02	SIDE PLATE, RH, PLATFORM
12C	1	281143-01	SIDE PLATE, LH, PLATFORM
12D	10	900705-01	SELF-TAPPING SCREW, 1/4"-20 X 1" LG.
13	1	281410-02	TORSION BAR HOLDER, RH
14	1	281414-02	TORSION BAR, RH

# PARTS BREAKDOWN FLIPOVER WITH SINGLE RETENTION RAMP (ALUMINUM)

**MAXON®**

11921 Slauson Ave. Santa Fe Springs, CA. 90670 (800) 227-4116 FAX (888) 771-7713

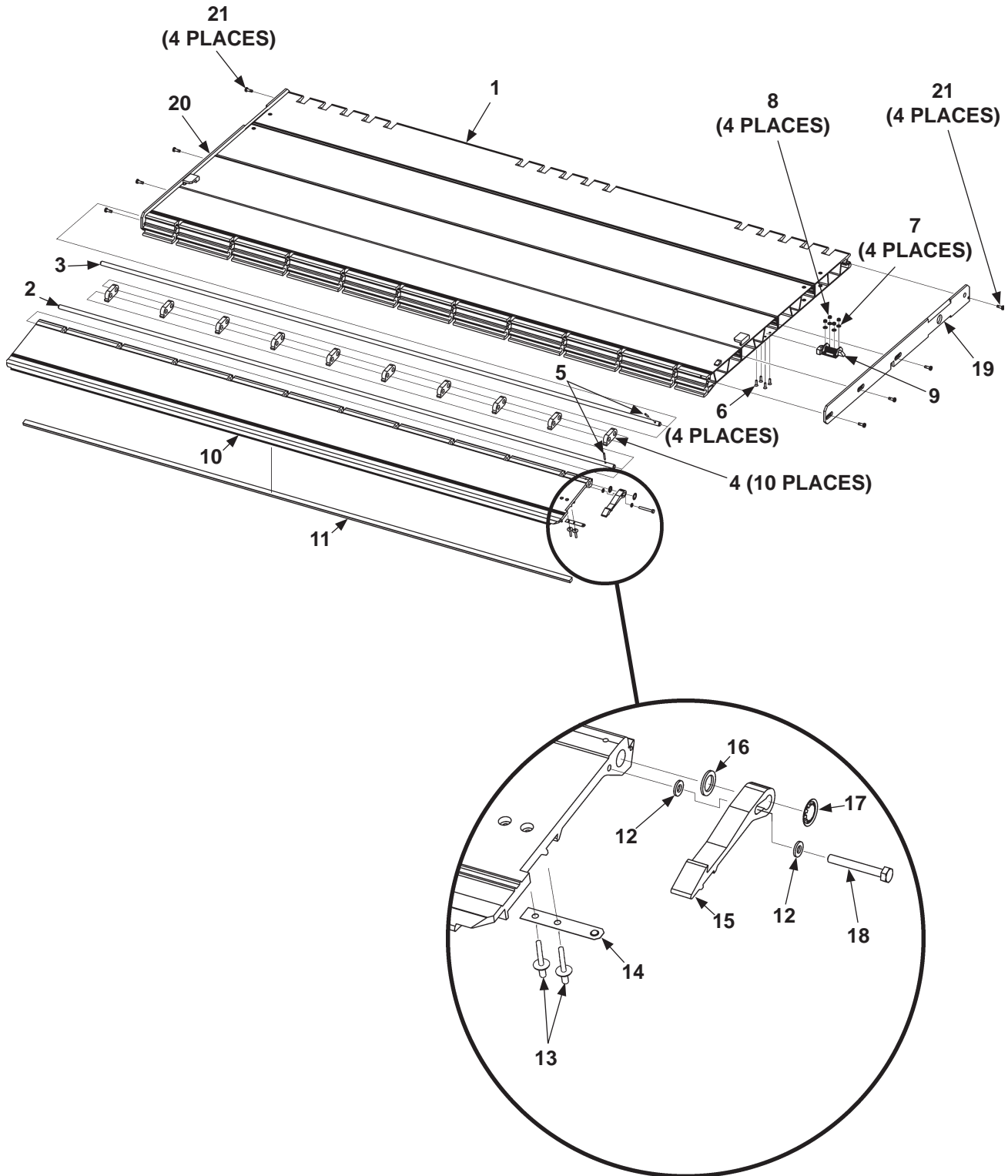



ITEM	QTY.	PART NO.	DESCRIPTION
REF	1	282533-01	FLIPOVER ASSEMBLY, 79-1/2" (WIDE)
		282533-02	FLIPOVER ASSEMBLY, 85-1/2" (WIDE)
1	1	282532-01	FLIPOVER WELDMENT, 79-1/2" (WIDE)
		282532-02	FLIPOVER WELDMENT, 85-1/2" (WIDE)
2	1	267045-01	HINGE, ROD, 78-9/16" LG. (79-1/2" WIDE FLIPOVER)
		267045-03	HINGE, ROD, 84-9/16" LG. (85-1/2" WIDE FLIPOVER)
3	1	267045-02	HINGE, ROD, 78-3/4" LG. (79-1/2" WIDE FLIPOVER)
		267045-04	HINGE, ROD, 84-3/4" LG. (85-1/2" WIDE FLIPOVER)
4	10	311022-10	HINGE ASSEMBLY
5	2	905007-07	ROLL PIN, 5/32" X 1" LG.
6	4	900028-4	PAN HEAD SCREW, #10-24 X 1" LG.
7	4	902013-07	FLAT WASHER, #10
8	4	901003	LOCK NUT, #10-24
9	1	267201-02	SLAM LATCH, 7/16" LG.
10	1	267041-01	RETENTION RAMP, 78" (WIDE)
		267041-02	RETENTION RAMP, 84" (WIDE)
11	1	905318-01	BUMPER, 74-1/2" LG. (79-1/2" WIDE FLIPOVER)
		905318-02	BUMPER, 80-1/2" LG. (85-1/2" WIDE FLIPOVER)
12	2	903421-02	FLAT WASHER, NYLON, 1/4", 1/16" THK.
13	2	904005-1	RIVET, 3/16" DIA. X 7/16" LG.
14	1	267326-01	SPRING, RETENTION RAMP HOOK
15	1	311038-11	RETENTION RAMP HOOK
16	1	903413-02	FLAT WASHER, NYLON, 1/2", 1/16" THK.
17	1	903420-01	RETAINING RING, SELF LOCKING, 1/2"
18	1	900004-8	CAP SCREW, 1/4"-20 X 2" LG, GRADE 8
19	1	267044-01	SIDE PLATE, FLIPOVER RH
20	1	267044-02	SIDE PLATE, FLIPOVER LH
21	8	900705-01	SELF-TAPPING SCREW, 1/4"-20 X 1" LG.

# PARTS BREAKDOWN PLATFORM & FLIPOVER ASSEMBLY (STEEL)

**NOTE:** This steel platform & flipover assembly is only available for GPTLR-25 & GPTLR-33.

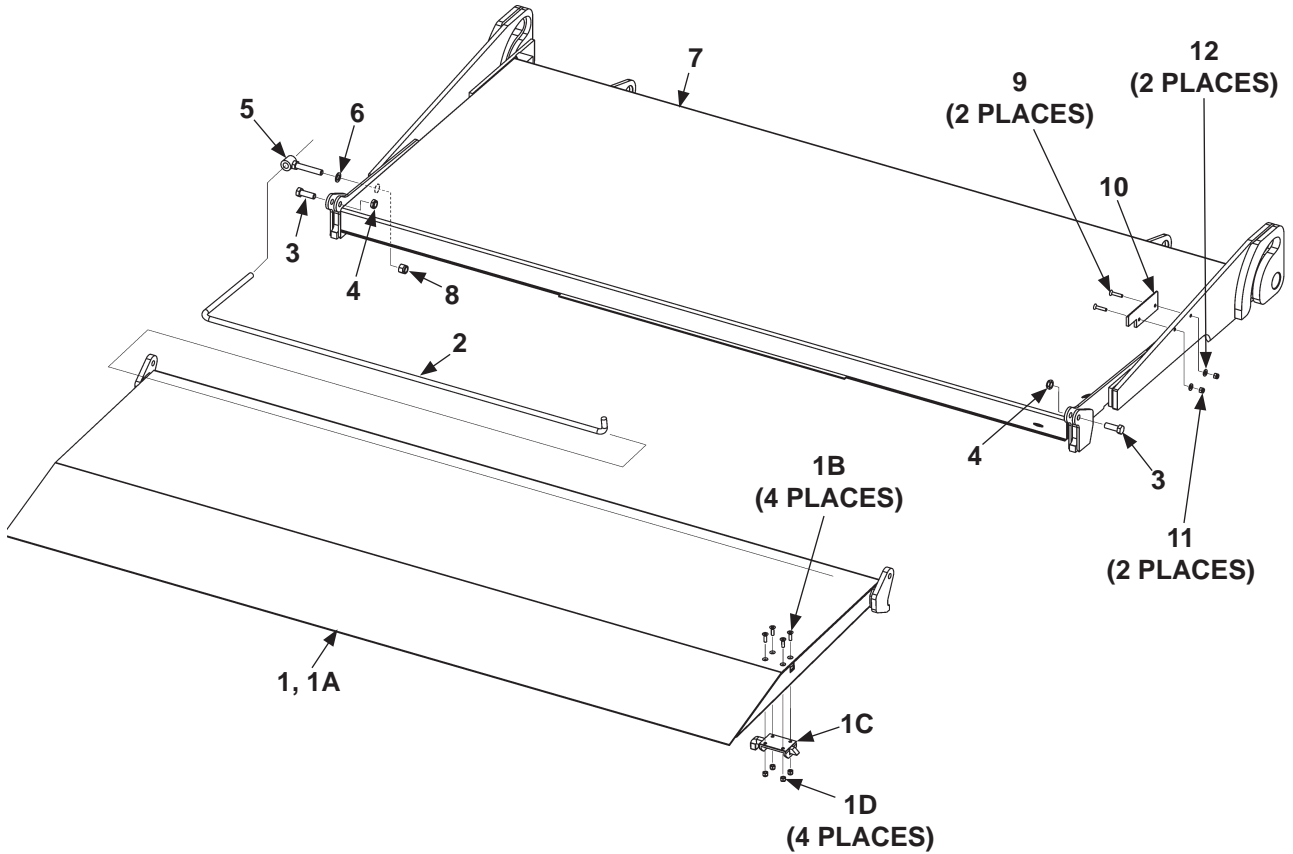

**MAXON**<sup>®</sup>

11921 Slauson Ave. Santa Fe Springs, CA. 90670 (800) 227-4116 FAX (888) 771-7713

ITEM	QTY.	PART NO.	DESCRIPTION
1	1	282510-01	FLIPOVER ASSEMBLY, 79" (WIDE)
		282510-02	FLIPOVER ASSEMBLY, 85" (WIDE)
1A	1	282507-01	FLIPOVER WELDMENT, 79" (WIDE)
		282507-02	FLIPOVER WELDMENT, 85" (WIDE)
1B	4	900044-5	FLAT HEAD SKT SCREW, 1/4"-20 X 7/8" LG, GRADE 8
1C	1	267201-03	SLAM LATCH, 1/2" LG.
1D	4	901000	LOCK NUT, 1/4"-20, GRADE 8
2	1	281302-01	TORSION BAR
3	2	900033-3	CAP SCREW, 1/2"-20 X 1-1/2" LG, GRADE 8
4	2	901016-1	LOCK NUT, THIN HEAD, 1/2"-20, GRADE 8
5	1	280749-01	ANCHOR BOLT
6	1	902000-14	FLAT WASHER, 1/2"
7	1	281770-01	PLATFORM WELDMENT, 79" (WIDE)
		281770-02	PLATFORM WELDMENT, 85" (WIDE)
8	1	901010	LOCK NUT, 1/2"-13, GRADE 8
9	2	900044-7	FLAT HEAD SKT SCREW, 1/4"-20 X 1-1/4" LG, GRADE 8
10	1	281415-01	BRACKET LATCH
11	2	901000	LOCK NUT, 1/4"-20, GRADE 8
12	2	902013-09	FLAT WASHER, 1/4"

## PUMP COVER & MOUNTING PLATE ASSEMBLY (GRAVITY DOWN)

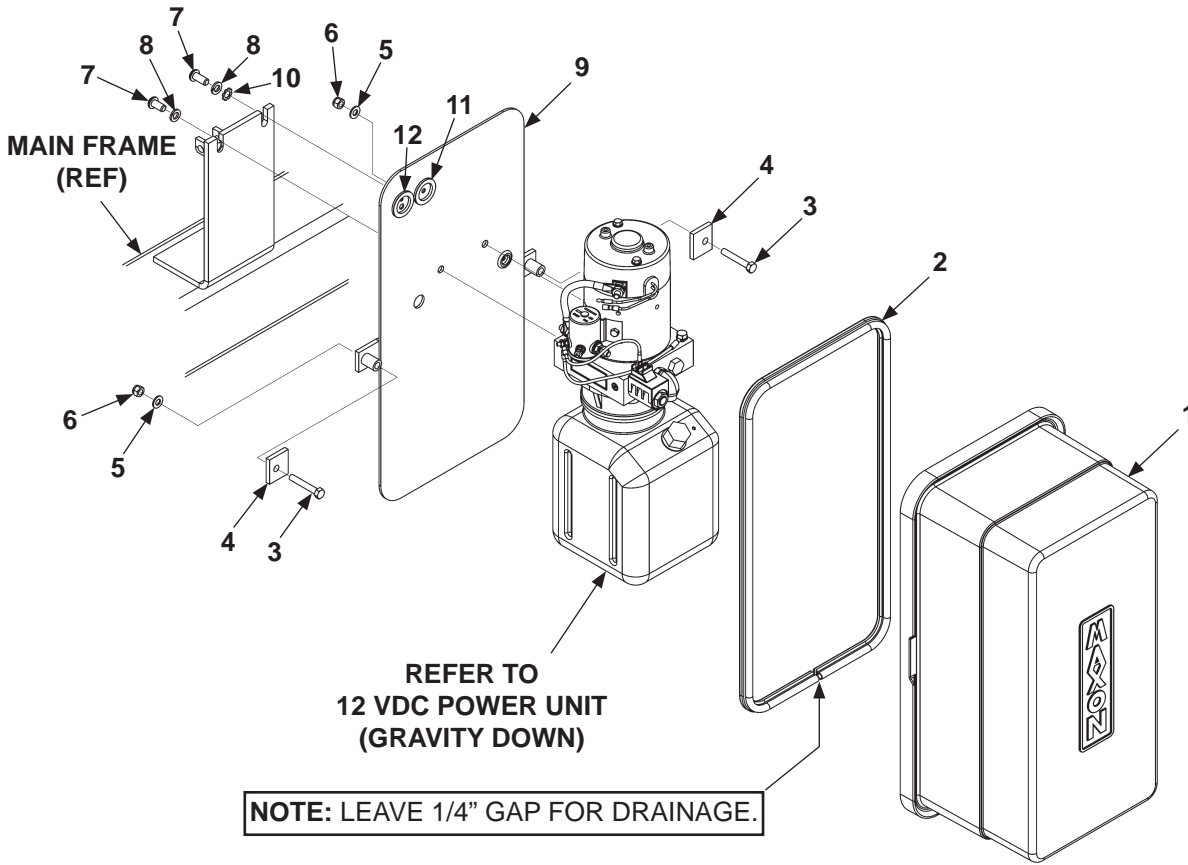

ITEM	QTY.	PART NO.	DESCRIPTION
REF	1	281059-01	PUMP ASSEMBLY
1	1	281038-01	COVER ASSY
2	1	093203-10	GASKET, RUBBER CHANNEL, 60" LG.
3	2	900009-8	CAP SCREW, 5/16"-18 X 2" LG.
4	2	281062-02	HOLDER FLATS
5	2	902013-10	FLAT WASHER, 5/16"
6	2	901001	LOCK NUT, 5/16"-18
7	2	900064-05	BUTTONHEAD SCREW, 3/8"-16 X 1" LG.
8	2	902011-4	LOCK WASHER, 3/8"
9	1	281065-01	PLATE, PUMP MOUNT
10	1	903400-02	LOCK WASHER, EXTERNAL TOOTH
11	1	266428-02	GROMMET, 1/4" HOLE
12	1	266428-08	GROMMET, 3/16" HOLE & 5/16" HOLE

**MAXON®**

11921 Slauson Ave. Santa Fe Springs, CA. 90670 (800) 227-4116 FAX (888) 771-7713

## PUMP COVER & MOUNTING PLATE ASSEMBLY (POWER DOWN)

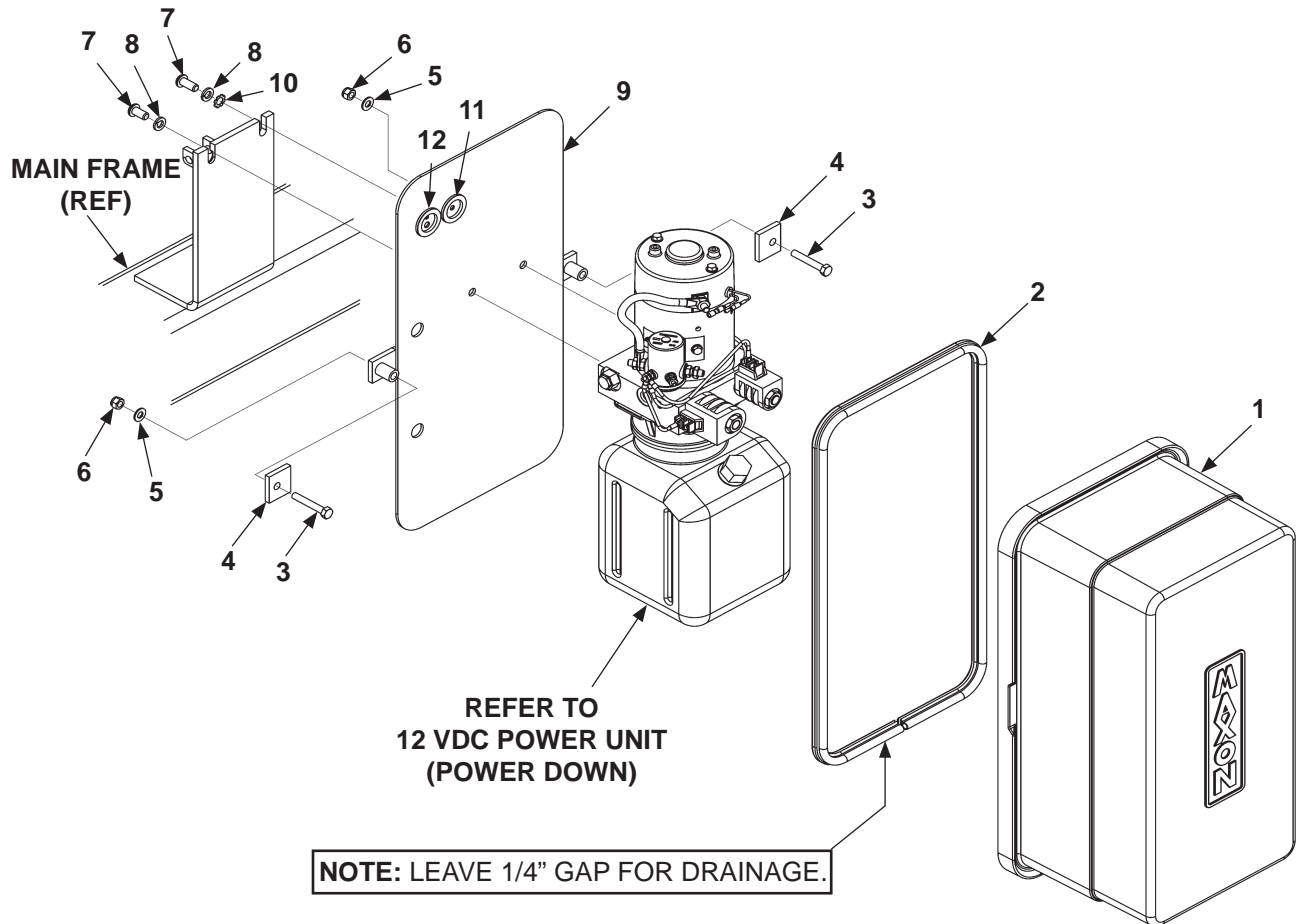

ITEM	QTY.	PART NO.	DESCRIPTION
REF	1	282330-01	PUMP ASSEMBLY
1	1	281038-01	COVER ASSY
2	1	093203-10	GASKET, RUBBER CHANNEL, 60" LG.
3	2	900009-8	CAP SCREW, 5/16"-18 X 2" LG.
4	2	281062-02	HOLDER FLATS
5	2	902013-10	FLAT WASHER, 5/16"
6	2	901001	LOCK NUT, 5/16"-18
7	2	900064-05	BUTTONHEAD SCREW, 3/8"-16 X 1" LG.
8	2	902011-4	LOCK WASHER, 3/8"
9	1	282322-01	PLATE, PUMP MOUNT
10	1	903400-02	LOCK WASHER, EXTERNAL TOOTH
11	1	266428-02	GROMMET, 1/4" HOLE
12	1	266428-08	GROMMET, 3/16" HOLE & 5/16" HOLE

# PARTS BREAKDOWN

## GRAVITY DOWN HYDRAULIC COMPONENTS

### CAUTION

To prevent incorrect operation & damage to Liftgate, make sure arrow on flow regulator valve points up as shown in illustration.

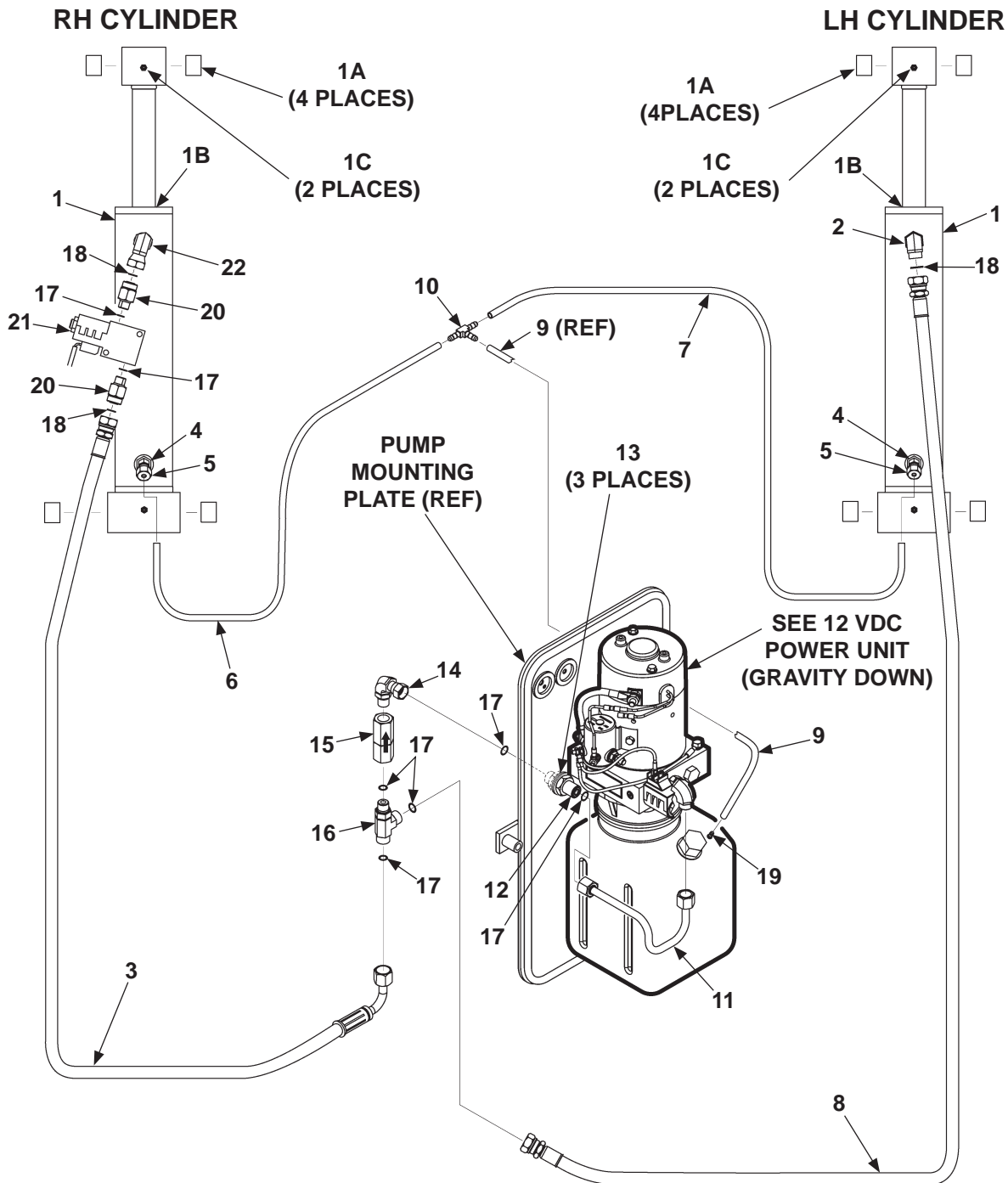

**MAXON®**

11921 Slauson Ave. Santa Fe Springs, CA. 90670 (800) 227-4116 FAX (888) 771-7713

ITEM	QTY.	PART NO.	DESCRIPTION
1	2	280990-01	CYLINDER, 2-3/4" x 11-1/2" STROKE (GPTLR-25/33)
		281035-01	CYLINDER, 3-1/4" X 12-1/2" STROKE (GPTLR-44)
		281040-01	CYLINDER 3-1/2" X 12-1/2" STROKE (GPTLR-55)
1A	4	908046-02	SELF-LUBE BEARING (GPTLR-25/33 CYLINDER)
		908047-02	SELF-LUBE BEARING (GPTLR-44/55 CYLINDER)
1B	1	280990SK-01	SEAL KIT (GPTLR-25/33 CYLINDER)
		281035SK-01	SEAL KIT (GPTLR-44 CYLINDER)
		281040SK-01	SEAL KIT (GPTLR-55 CYLINDER)
1C	2	224342	GREASE FITTING
2	1	906704-01	ELBOW, 90° FACE SEAL, #8 M-M (WITH O-RING)
3	1	281069-01	HOSE ASSY, 3/8" HP, 43" LG.
4	2	228012	ADAPTER, STRAIGHT THREAD, 9/16"-18 M - 1/4" F
5	2	263811	ELBOW, MALE 45°
6	1	224370-21	HOSE, PLASTIC 38" LG.
7	1	224370-22	HOSE, PLASTIC 107" LG.
8	1	281057-02	HOSE ASSY, 3/8" HP, 121" LG.
9	1	224370-20	HOSE, PLASTIC 9" LG.
10	1	906749-01	UNION TEE
11	1	281067-01	FACE SEAL TUBE ASSY
12	1	906744-01	BULKHEAD UNION (WITH O-RING)
13	3	902028-12	FLAT WASHER, 3/4"
14	1	906708-01	ELBOW, 90° FACE SEAL, #6 M-M
15	1	906709-04	FLOW REGULATOR VALVE, 4.5 GPM
16	1	906754-01	BRANCH TEE (WITH O-RINGS)
17	7	906712-02	O-RING, #6 (3/8" FACE SEAL, TUBE-END)
18	3	906712-03	O-RING, #8 (1/2" FACE SEAL, TUBE-END)
19	1	906728-01	DUAL BARBED FITTING
20	2	906762-01	CONNECTOR, M-M, 9/16"-18 X 3/4" (WITH O-RING)
21	1	281308-01	LOCK VALVE
22	1	906763-01	CONNECTOR ELBOW, M-M, 9/16"-18 X 13/16"-16 (WITH O-RING)

# PARTS BREAKDOWN POWER DOWN HYDRAULIC COMPONENTS

## CAUTION

To prevent incorrect operation & damage to Liftgate, make sure arrow on flow regulator valve points up as shown in illustration.

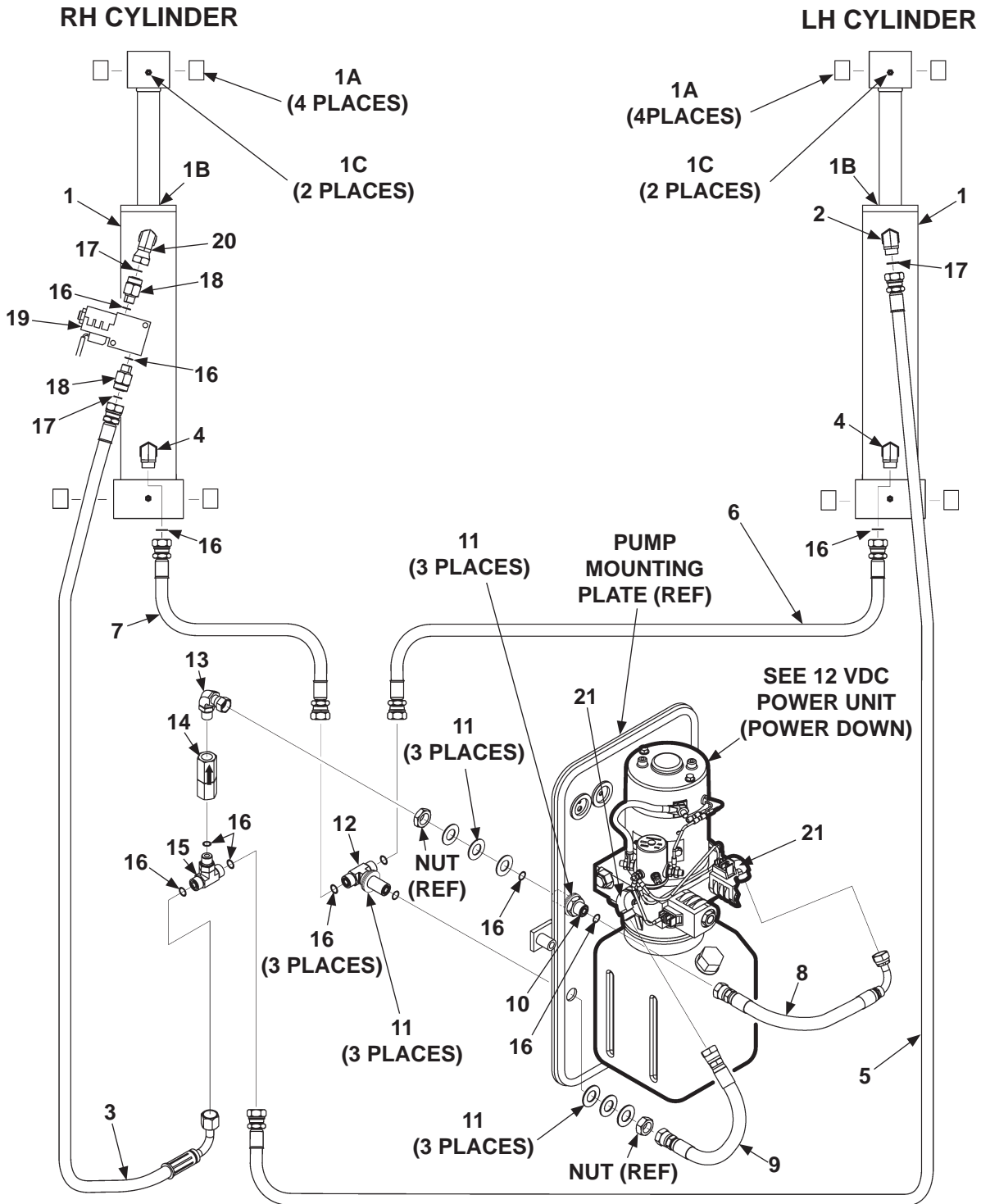

**MAXON**

11921 Slauson Ave. Santa Fe Springs, CA. 90670 (800) 227-4116 FAX (888) 771-7713



ITEM	QTY.	PART NO.	DESCRIPTION
1	2	280990-01	CYLINDER, 2-3/4" x 11-1/2" STROKE (GPTLR-25/33)
		281035-01	CYLINDER, 3-1/4" X 12-1/2" STROKE (GPTLR-44)
		281040-01	CYLINDER, 3-1/2" X 12-1/2" STROKE (GPTLR-55)
1A	4	908046-02	SELF-LUBE BEARING (GPTLR-25/33 CYLINDER)
		908047-02	SELF-LUBE BEARING (GPTLR-44/55 CYLINDER)
1B	1	280990SK-01	SEAL KIT (GPTLR-25/33 CYLINDER)
		281035SK-01	SEAL KIT (GPTLR-44 CYLINDER)
		281040SK-01	SEAL KIT (GPTLR-55 CYLINDER)
1C	2	224342	GREASE FITTING
2	1	906704-01	ELBOW, 90° FACE SEAL, #8 M-M (WITH O-RING)
3	1	282392-01	HOSE ASSY, 3/8" HP, 43" LG.
4	2	906775-01	ELBOW, 90° FACE SEAL, #6 M-M (WITH O-RING)
5	1	281057-02	HOSE ASSY, 3/8" HP, 121" LG.
6	1	282391-01	HOSE ASSY, 3/8" HP, 116" LG.
7	1	282393-01	HOSE ASSY, 3/8" HP, 40" LG.
8	1	282324-01	HOSE ASSY, 3/8" HP, #6 F SWIVEL 90° ELBOW
9	1	282325-01	HOSE ASSY, 3/8" HP, #6 F-F SWIVEL
10	1	906744-01	BULKHEAD UNION, #6 (WITH O-RING)
11	12	902028-12	FLAT WASHER, 3/4"
12	1	906810-01	BRANCH TEE BULKHEAD, #6 (WITH O-RING)
13	1	906708-01	ELBOW, 90° FACE SEAL, #6 M-M (WITH O-RING)
14	1	906709-04	FLOW REGULATOR VALVE, 4.5 GPM
15	1	906745-01	BRANCH TEE, #6 (WITH O-RINGS)
16	12	906712-02	O-RING, #6 (3/8" FACE SEAL TUBE-END)
17	3	906712-03	O-RING, #8 (1/2" FACE SEAL TUBE-END)
18	2	906762-01	CONNECTOR, M-M, 9/16"-18 X 3/4" (WITH O-RING)
19	1	281308-01	HYDRAULIC LOCK
20	1	906763-01	CONNECTOR, M-M, 9/16"-18 X 13/16"-16 (WITH O-RING)
21	2	906707-01	ELBOW, 90°, FACE SEAL, #6 M-M (WITH O-RING)

**MAXON** 11921 Slauson Ave. Santa Fe Springs, CA. 90670 (800) 227-4116 FAX (888) 771-7713

# PARTS BREAKDOWN

## 12 VDC POWER UNIT (GRAVITY DOWN)

### CAUTION

Do not over-tighten the terminal nuts on starter solenoid. For the load terminals, torque nuts to 40 lbs.-in. max. Torque the nuts on #10-32 control terminals 15-20 lbs.-in.

### CAUTION

To prevent damage when installing 2-way valves, torque valve cartridge nut to 30 lbs.-in. max.

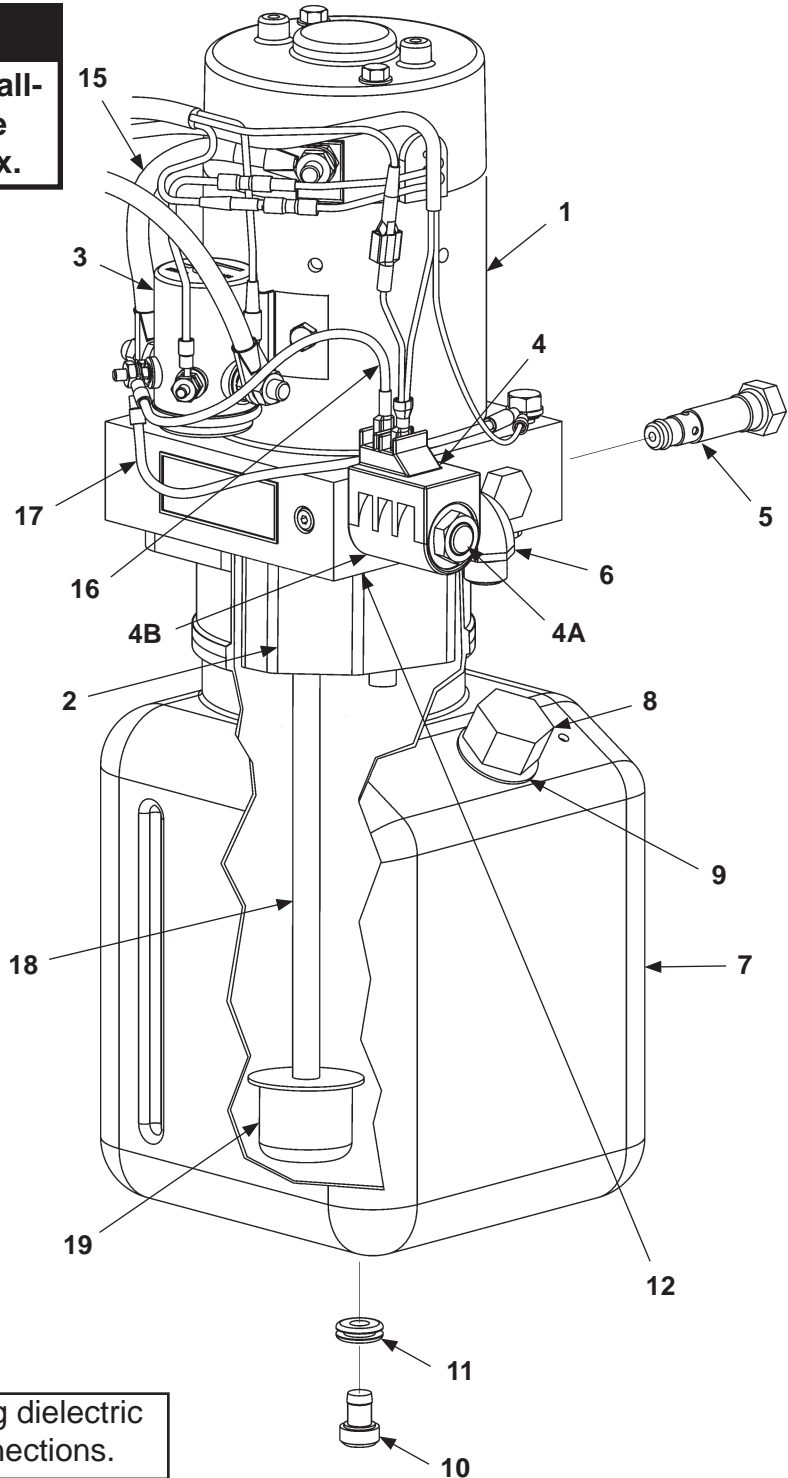

**NOTE:** MAXON recommends using dielectric grease on all electrical connections.

**MAXON**<sup>®</sup>

11921 Slauson Ave. Santa Fe Springs, CA. 90670 (800) 227-4116 FAX (888) 771-7713

ITEM	QTY.	PART NO.	DESCRIPTION
REF	1	282321-01	12 VDC POWER UNIT, GRAVITY DOWN
1	1	280374	12 VDC MOTOR
2	1	290002	3-PIECE GEAR PUMP
3	1	268029-01	SWITCH, SOLENOID (12 VDC)
4	1	290043	VALVE ASSEMBLY, 2-WAY
4A	1	290044	VALVE CARTRIDGE (2-WAY VALVE)
4B	1	290045	COIL, DOUBLE SPADE (2-WAY VALVE)
5	1	906737-01	CARTRIDGE RELIEF VALVE
6	1	906707-01	ELBOW, SAE #6, FACE SEAL O-RING, M-M
7	1	281438-01	RESERVOIR, VERTICAL (5 QUART)
8	1	280806-01	FILLER, BREATHER CAP
9	1	908016-01	RUBBER GROMMET, 3/4" I.D. (FILLER CAP)
10	1	908017-01	PLUG, DRAIN PORT
11	1	908018-01	RUBBER GROMMET, 5/16" I.D. (DRAIN PLUG)
12	1	290061	SEAL, SQUARE CUT (FOR RESERVOIR)
13	1	260261	OIL SEAL (NOT SHOWN FOR 3-PIECE GEAR PUMP)
14	1	290020	O-RING (NOT SHOWN FOR 3-PIECE GEAR PUMP)
15	1	280404	CABLE ASSEMBLY
16	1	280416	WIRE ASSEMBLY (#10 RING & QUICK DISCONN. TERMINALS)
17	1	268027-01	WIRE ASSY, 18 GA (#10 RING & 5/16" RING TERMINALS)
18	1	290075	SUCTION TUBE, PLASTIC
19	1	290073	INLET FILTER

# PARTS BREAKDOWN

## 12 VDC POWER UNIT (POWER DOWN)

### CAUTION

Do not over-tighten the terminal nuts on starter solenoid. For the load terminals, torque nuts to 40 lbs.-in. max. Torque the nuts on #10-32 control terminals 15-20 lbs.-in.

### CAUTION

To prevent damage when installing 2-way valves, torque valve cartridge nut to 30 lbs.-in. max.

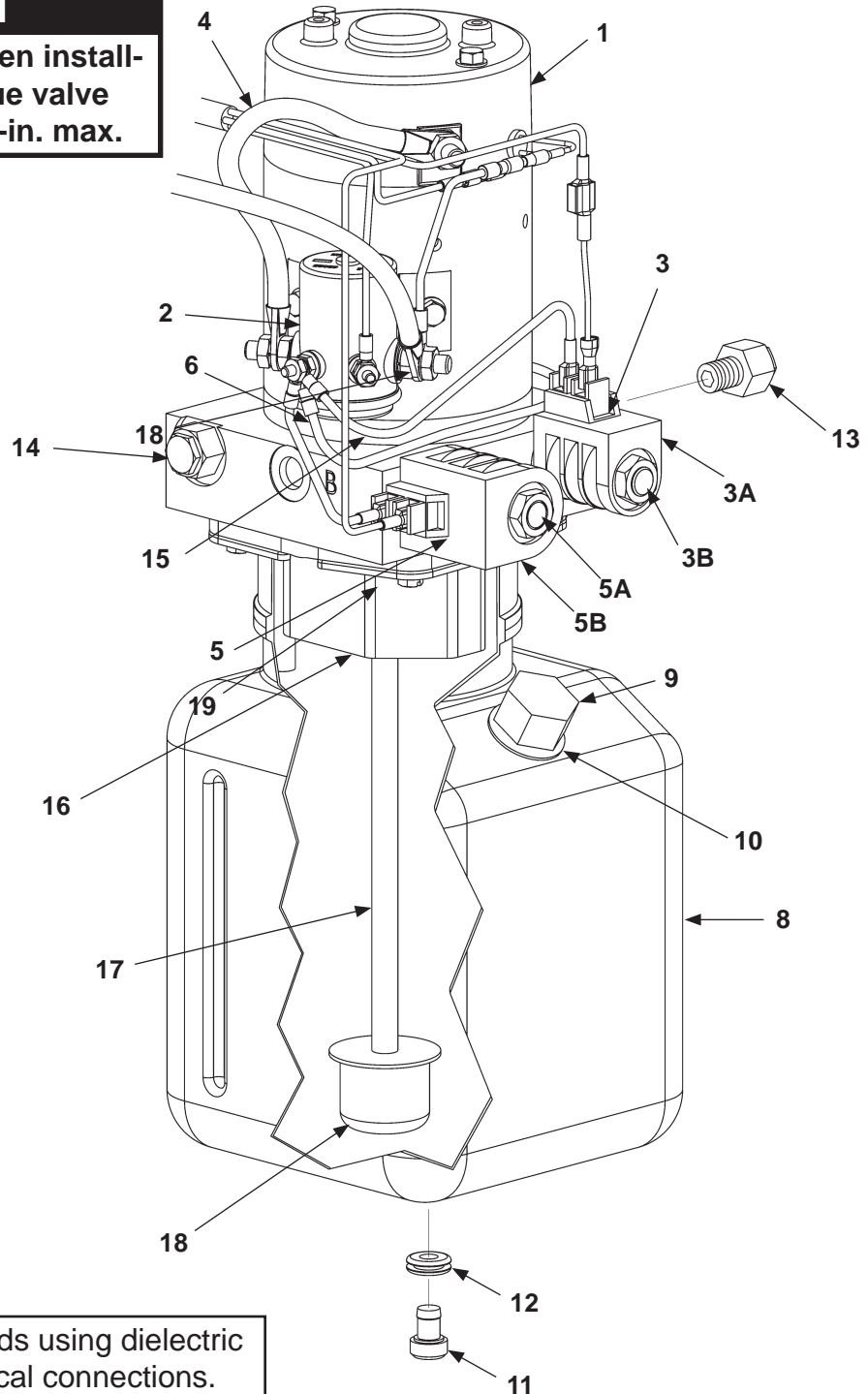

**NOTE:** MAXON recommends using dielectric grease on all electrical connections.

**MAXON**<sup>®</sup>

11921 Slauson Ave. Santa Fe Springs, CA. 90670 (800) 227-4116 FAX (888) 771-7713

ITEM	QTY.	PART NO.	DESCRIPTION
REF	1	282331-01	12 VDC POWER UNIT, POWER DOWN
1	1	268176-01	12 VDC MOTOR
2	1	268029-01	SWITCH, SOLENOID (12 VDC)
3	1	906821-01	VALVE ASSEMBLY, 2-WAY
3A	1	290045	COIL, DOUBLE SPADE (2-WAY VALVE)
3B	1	906822-01	VALVE CARTRIDGE (2-WAY VALVE)
4	1	280404	CABLE ASSEMBLY
5	1	290046	VALVE ASSEMBLY, 4-WAY
5A	1	290047	VALVE CARTRIDGE (4-WAY VALVE)
5B	1	290048	COIL, DOUBLE SPADE (4-WAY VALVE)
6	1	268079-01	WIRE ASSEMBLY, 18 GA, (#10 RING & 5/16 RING TERMINALS)
7	1	261067	PLUG, O-RING, SAE #6
8	1	281437-01	RESERVOIR, VERTICAL (5 QUART)
9	1	280806-01	FILLER, BREATHER CAP
10	1	908016-01	GROMMET (FILLER CAP)
11	1	908017-01	PLUG, DRAIN PORT
12	1	908018-01	RUBBER GROMMET, 5/16" I.D. (DRAIN PLUG)
13	1	906738-02	RELIEF VALVE, ADJUSTABLE, 3200 PSI
14	1	268174-01	RELIEF VALVE, ADJUSTABLE, 1100 PSI
15	2	280416	WIRE ASSY (#10 RING & QUICK DISCONN. TERMINALS)
16	1	906781-01	PUMP ASSY, POWER DOWN (GEAR PUMP & MANIFOLD)
17	1	290103	SUCTION TUBE, PLASTIC
18	1	290073	INLET FILTER

**MAXON**

11921 Slauson Ave. Santa Fe Springs, CA. 90670 (800) 227-4116 FAX (888) 771-7713

**DECALS**

**OPERATING INSTRUCTIONS**

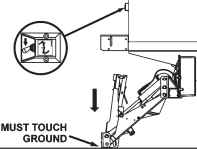
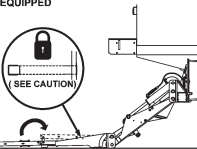
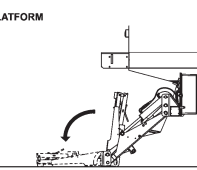
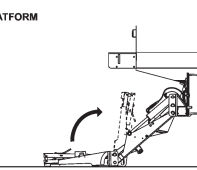
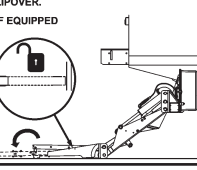
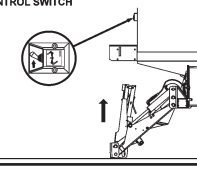
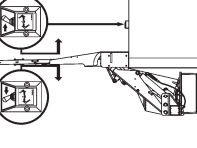
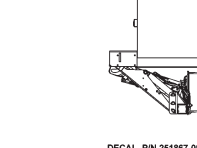
OPERATE	STOW
<p><b>PUSH CONTROL SWITCH</b></p>  <p>1 MUST TOUCH GROUND</p>	<p><b>FOLD FLIPOVER. LATCH IF EQUIPPED</b></p>  <p>1 (SEE CAUTION)</p>
<p><b>UNFOLD PLATFORM</b></p>  <p>2</p>	<p><b>FOLD PLATFORM</b></p>  <p>2</p>
<p><b>UNFOLD FLIPOVER. UNLATCH IF EQUIPPED</b></p>  <p>3</p>	<p><b>PUSH CONTROL SWITCH</b></p>  <p>3</p>
<p><b>RAISE/LOWER</b></p>  <p>4</p>	<p><b>STOWED</b></p>  <p>4</p>

DECAL, P/N 251867-09

**INSTRUCTION DECAL  
P/N 251867-09.**

**WARNING**

**READ THIS INFORMATION CAREFULLY**

- Improper operation of this Liftgate can result in serious personal injury. Do not operate unless you have been properly instructed and have read, and are familiar with the operating instructions. If you do not have a copy of the instructions, please obtain them from your employer, distributor, or lessor before you attempt to operate Liftgate.
- Be certain that the vehicle is properly and securely braked before using the Liftgate.
- Always inspect this Liftgate for maintenance or damage before using it. If there are signs of improper maintenance, damage to vital parts, or slippery Platform surface, do not use the Liftgate until these problems have been corrected.
- Do not overload the Liftgate. The load limit is based on evenly distributed cargo over the entire Platform surface. If you are using a pallet jack, be sure it can be maneuvered safely. Do not operate a forklift on the Platform or travel with the platform in an open position at any time.
- Load should be placed in a stable position close to the edge of the Platform nearest the truck. The heaviest portion of the load should never be placed beyond the center of the Platform away from the truck.
- Never allow yourself, a helper, or bystander to stand in a position where a falling load could land on either of you. Also do not allow any part of yours or your helper's body to be placed under, within, or around any portion of the moving Liftgate, or its mechanisms, or in a position that would trap them between the platform and the ground or truck when the Liftgate is operated.
- If a helper is riding the Platform with you, make sure you are both doing so safely and that you are not in danger of coming in contact with any moving or potentially moving obstacles. USE GOOD COMMON SENSE. If load appears to be unsafe, do not lift or lower it.

For a free copy of other manuals that pertain to this model Liftgate, please visit our website at [www.maxonlift.com](http://www.maxonlift.com) or call Customer Service at (800) 227- 4116.

MAXON LIFT CORP. PART NO. 264081

**WARNING DECAL  
P/N 264081**

**WARNING**



NEVER OPERATE LIFTGATE WHEN WALK RAMP IS EXTENDED.

ALWAYS STOW WALK RAMP BEFORE OPERATING LIFTGATE.

DECAL, P/N 265441-01

**WALK RAMP  
WARNING DECAL  
(WALK RAMP  
EQUIPPED VEHICLES  
ONLY)  
P/N 265441-01**

**NOTICE**

- 1 LOWER LIFTGATE TO GROUND BEFORE YOU SET UP WALK RAMP. REFER TO LIFTGATE OPERATING INSTRUCTIONS DECAL.
- 2 READ WALK RAMP WARNING DECAL BEFORE YOU SET UP WALK RAMP.
- 3 TO SET UP WALK RAMP & STOW WALK RAMP, REFER TO WALK RAMP MANUFACTURER'S INSTRUCTIONS.
- 4 TO STOW LIFTGATE (AFTER WALK RAMP IS STOWED), REFER TO LIFTGATE OPERATING INSTRUCTIONS DECAL.

DECAL, P/N 266013-01

**WALK RAMP  
NOTICE DECAL  
(WALK RAMP EQUIPPED  
VEHICLES ONLY)  
P/N 266013-01**

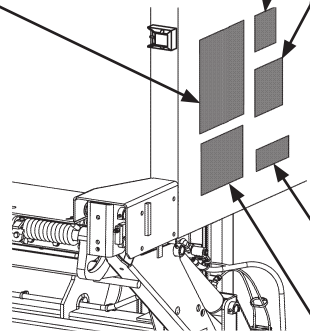

THE MAXIMUM CAPACITY OF THIS LIFT IS

**POUNDS**

WHEN THE LOAD IS CENTERED ON PLATFORM

**CAPACITY DECAL  
(SEE TABLE 78-1)**

CAPACITY DECALS	
CAPACITY	PART NO.
2500 LBS.	220382
3300 LBS.	220388-02
4400 LBS.	253155
5500 LBS.	253161

**TABLE 78-1**

**FIG. 78-1**



**WARNING DECAL**  
P/N 265736-03

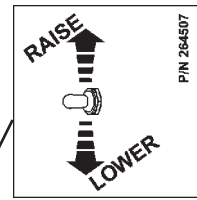

**CONTROL SWITCH DECAL**  
P/N 264507



**PAINT DECAL**  
P/N 267338-01

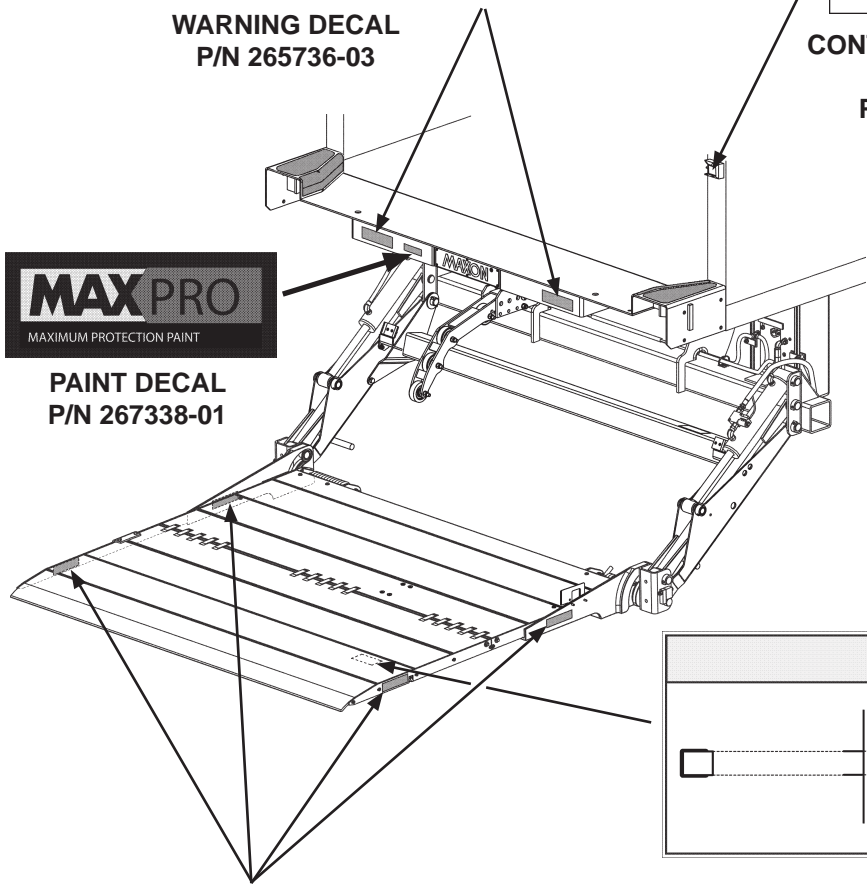

**CAUTION DECAL**  
(FLIPOVER EQUIPPED WITH LATCH ONLY)  
P/N 267694-01

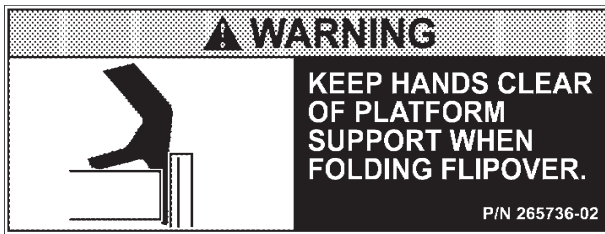

**WARNING DECAL**  
P/N 265736-02

**MAXON** 11921 Slauson Ave. Santa Fe Springs, CA. 90670 (800) 227-4116 FAX (888) 771-7713

**FIG. 79-1**

# PARTS BREAKDOWN NONSKID & SAFETY STRIPING

**MAXON**<sup>®</sup>

11921 Slauson Ave. Santa Fe Springs, CA. 90670 (800) 227-4116 FAX (888) 771-7713

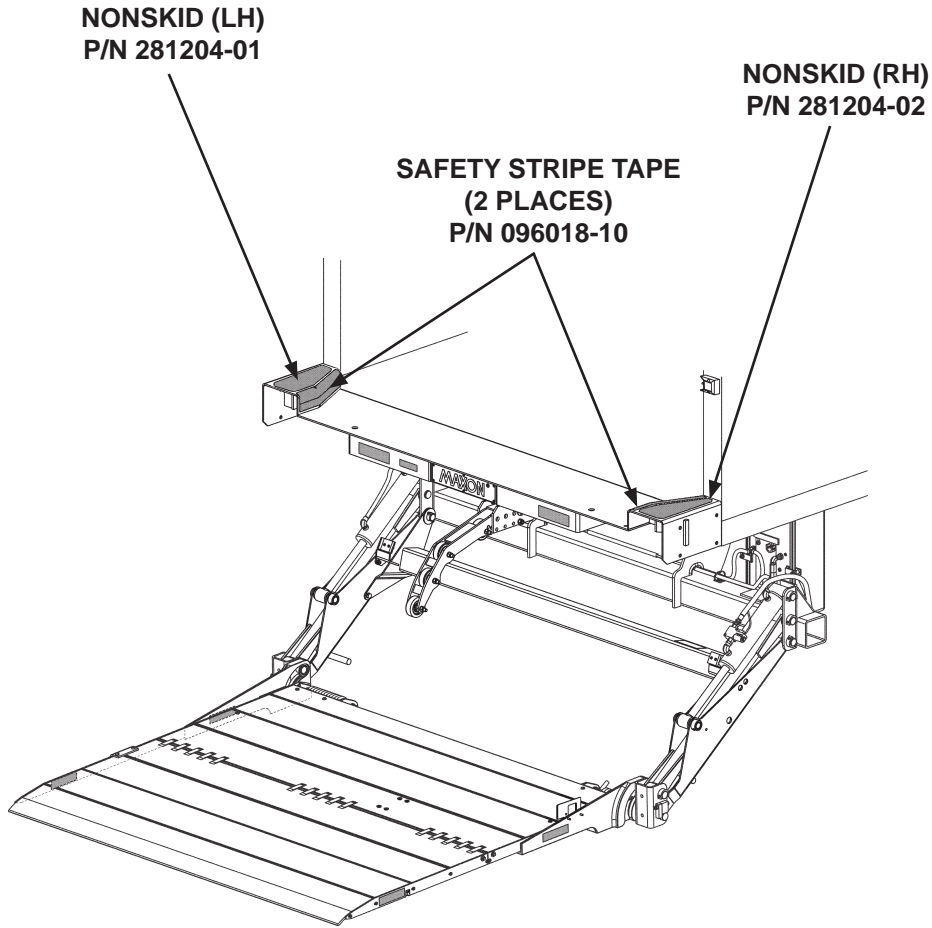

**FIG. 80-1**



## CONTROL SWITCH AND POWER CABLE

**NOTE:** Use switch to **RAISE** and **LOWER** Liftgate to make sure switch operates as shown on the decal.

**NOTE:** MAXON recommends using dielectric grease on all electrical connections.

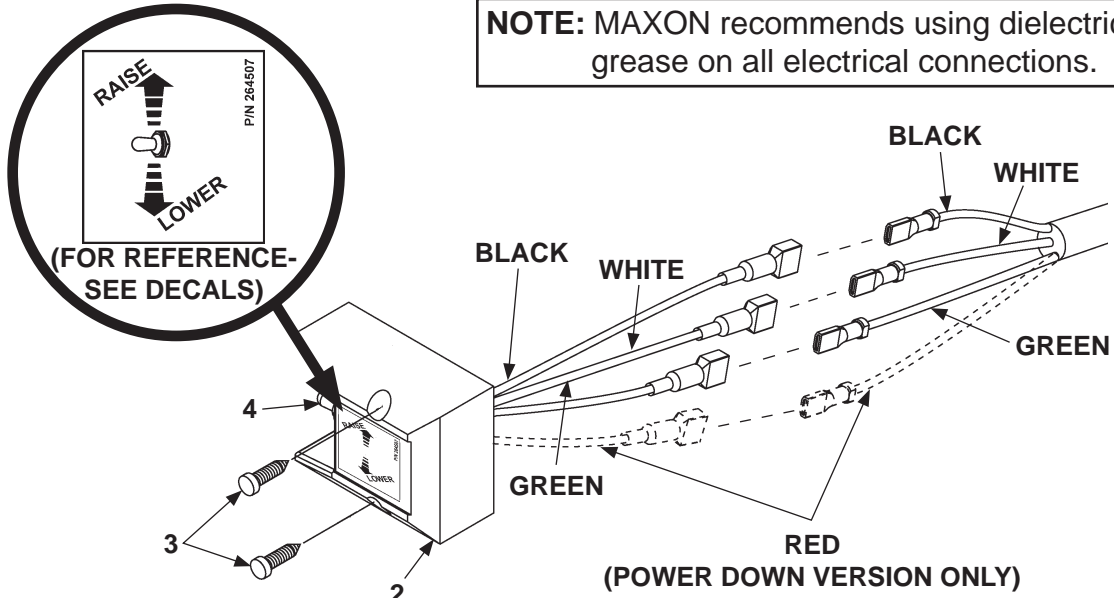

ITEM	QTY.	PART NO.	DESCRIPTION
1	1	268025-01	CABLE ASSEMBLY, 85" LG. (GRAVITY DOWN)
		268170-01	CABLE ASSEMBLY, 85" LG. (POWER DOWN)
2	1	267959-01	MOLDED SWITCH ASSEMBLY (GRAVITY DOWN)
		264951-04	MOLDED SWITCH ASSEMBLY (POWER DOWN)
3	2	900057-5	SCREW, SELF-TAPPING #10-24 X 1" LG.
4	1	905206	SWITCH BOOT SEAL
5	1	264422	CABLE ASSEMBLY, 200 AMPS, 38' LG.
6	1	264687	KIT, MEGAFUSE (200 AMP FUSE & HEATSHRINK TUBING)

**TABLE 81-1**

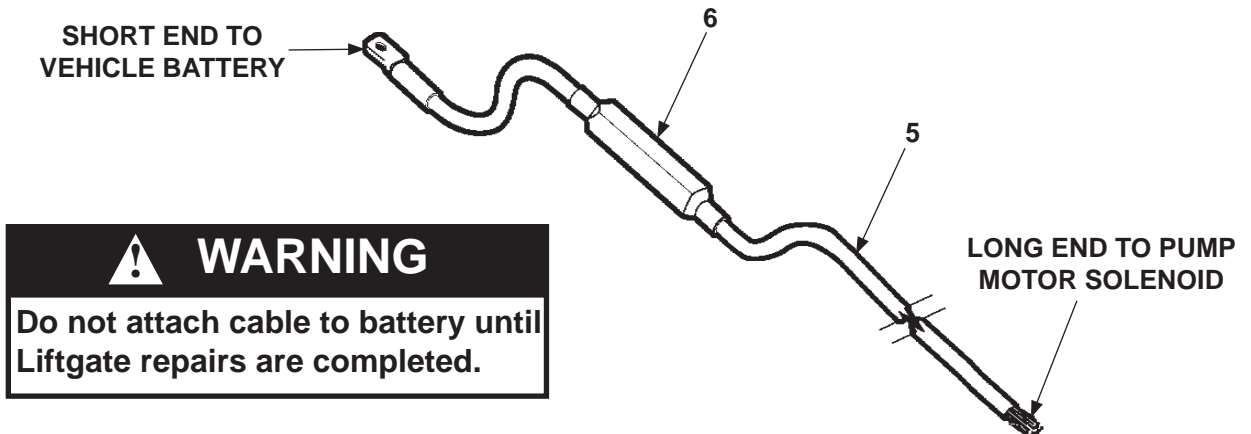

# SYSTEM DIAGRAMS

## PUMP & MOTOR SOLENOID OPERATION (GRAVITY DOWN)

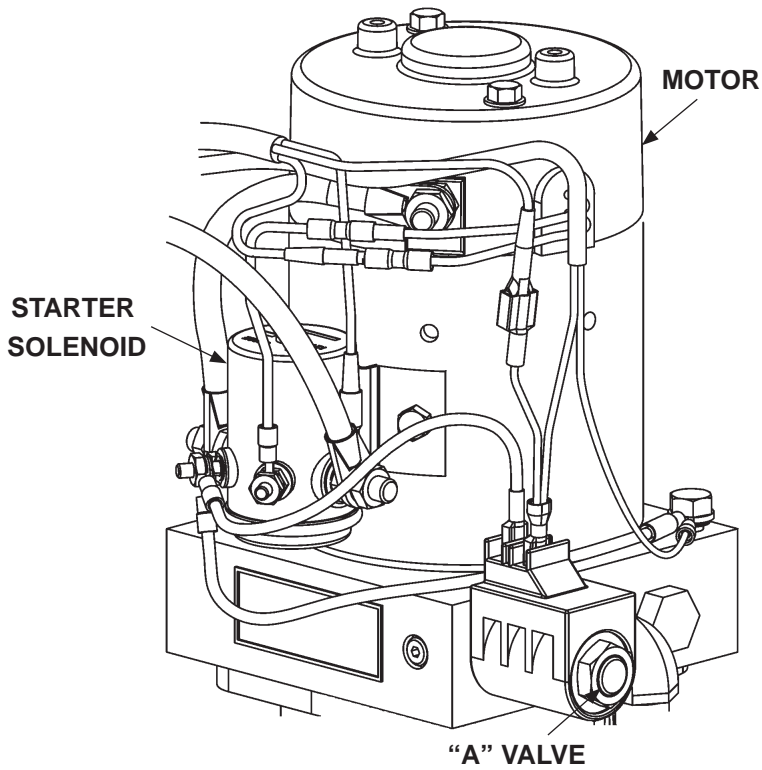

**GRAVITY DOWN POWER UNIT  
FIG. 82-1**

POWER UNIT MOTOR & SOLENOID OPERATION				
LIFTGATE FUNCTION	PORT	SOLENOID OPERATION (✓ MEANS ENERGIZED)		
		MOTOR	VALVE "A"	LOCK VALVE
RAISE	A	✓	-	-
LOWER	VENT	-	✓	✓
REFER TO VALVES SHOWN ON HYDRAULIC SCHEMATIC				

**TABLE 82-1**

## PUMP & MOTOR SOLENOID OPERATION (POWER DOWN)

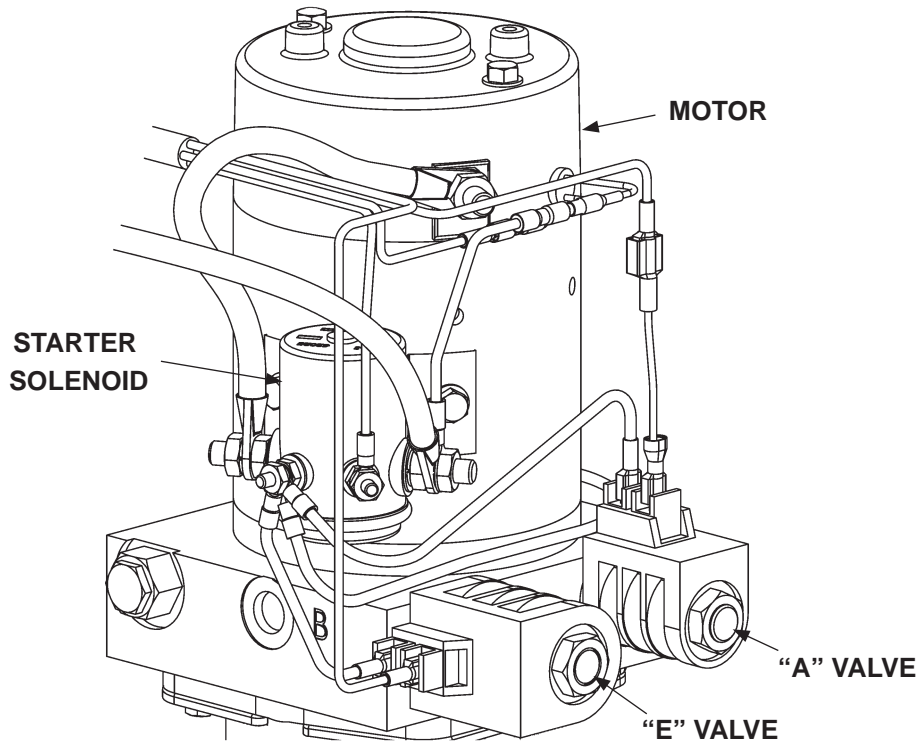

**POWER DOWN POWER UNIT  
FIG. 83-1**

POWER UNIT MOTOR & SOLENOID OPERATION					
LIFTGATE FUNCTION	PORT	SOLENOID OPERATION (✓ MEANS ENERGIZED)			
		MOTOR	VALVE "A"	VALVE "E"	LOCK VALVE
RAISE	A	✓	-	✓	-
LOWER	B	✓	✓	-	✓
REFER TO VALVES SHOWN ON HYDRAULIC SCHEMATIC					

**TABLE 83-1**

# HYDRAULIC SCHEMATIC (GRAVITY DOWN)

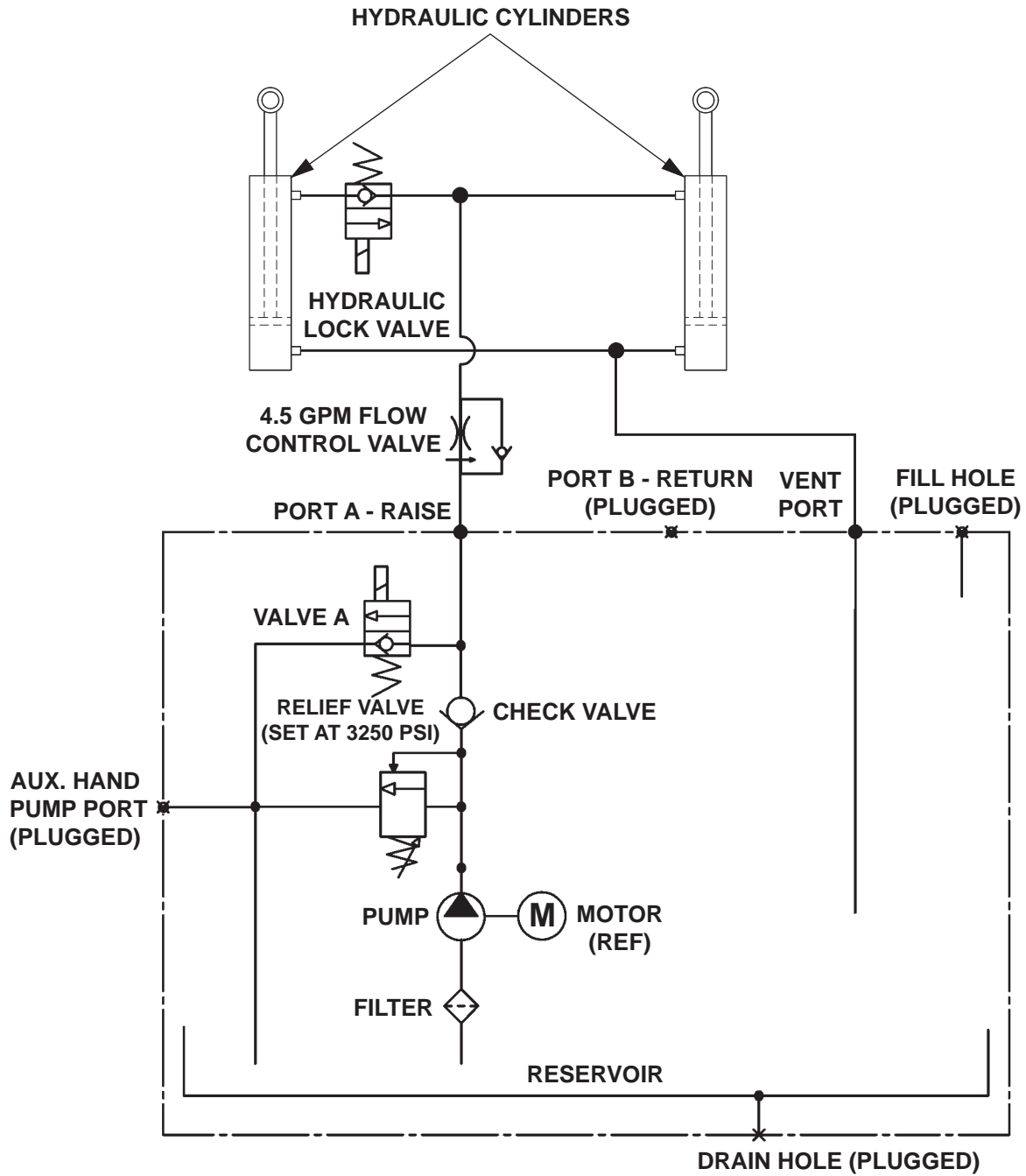

FIG. 84-1

**MAXON**

11921 Slauson Ave. Santa Fe Springs, CA. 90670 (800) 227-4116 FAX (888) 771-7713

# HYDRAULIC SCHEMATIC (POWER DOWN)

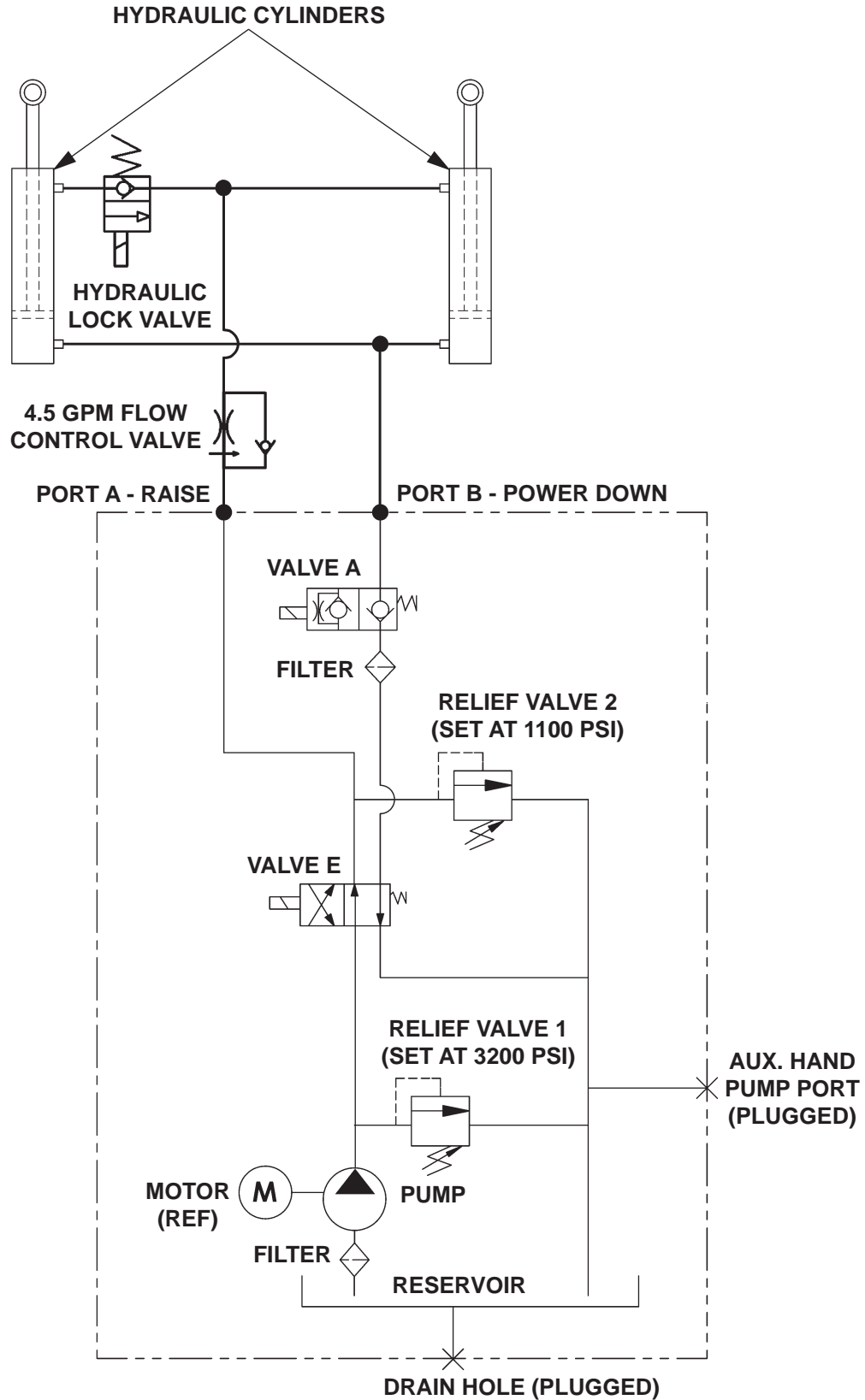

FIG. 85-1

# ELECTRICAL SCHEMATIC (GRAVITY DOWN)

**MAXON**<sup>®</sup>

11921 Slauson Ave. Santa Fe Springs, CA. 90670 (800) 227-4116 FAX (888) 771-7713

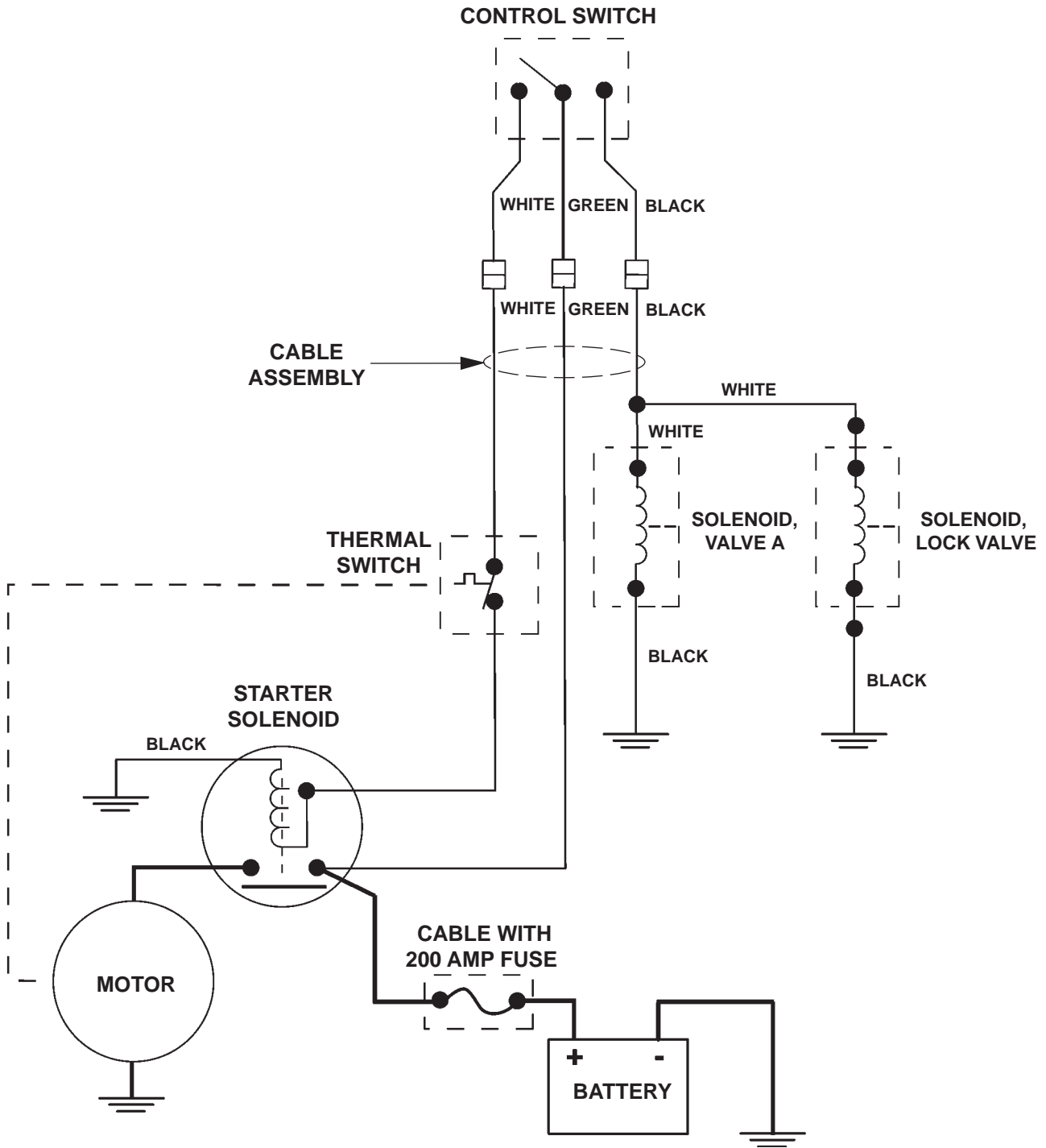

FIG. 86-1

# ELECTRICAL SCHEMATIC (POWER DOWN)

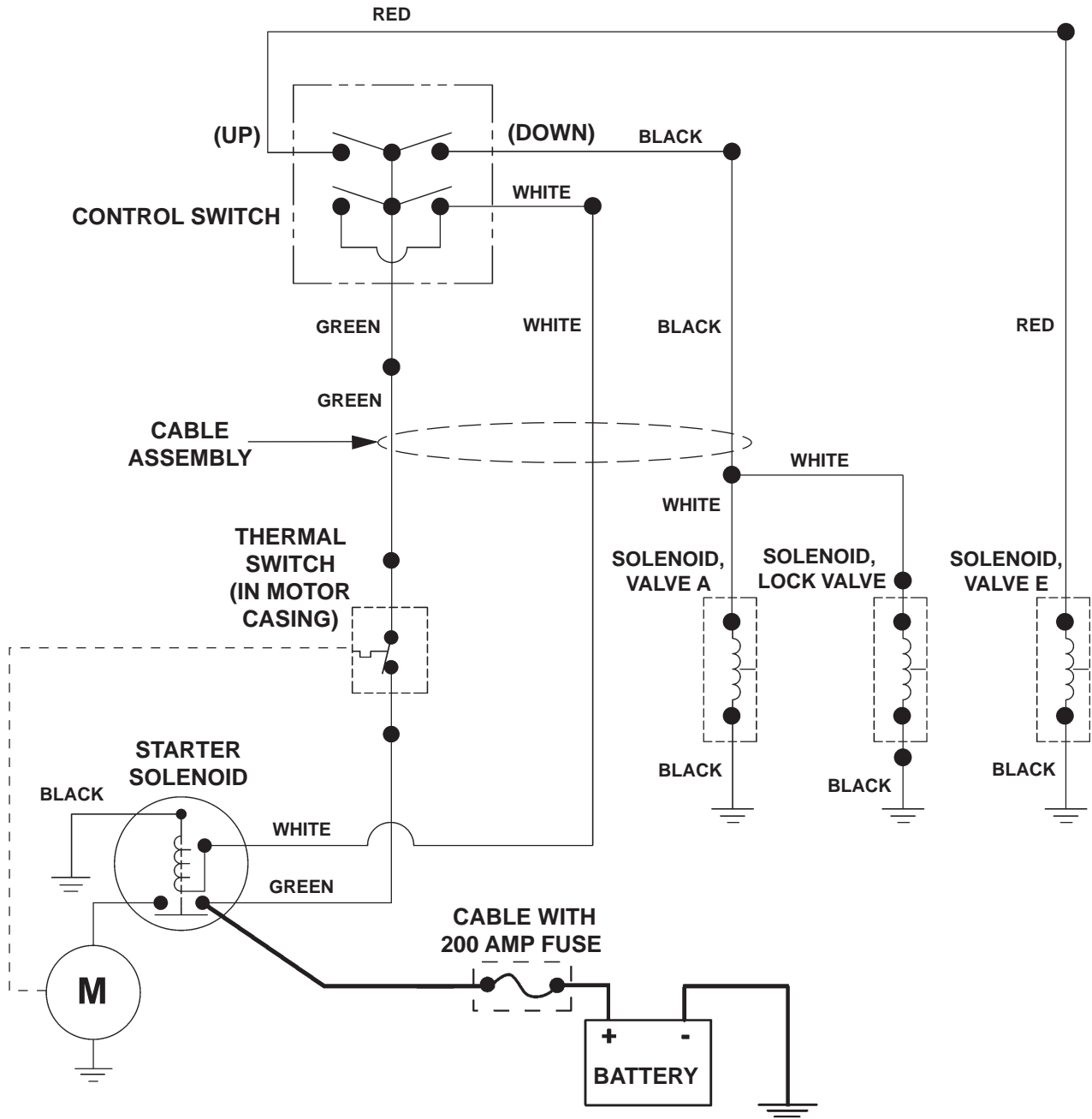

FIG. 87-1

# RECOMMENDED BOLT TORQUES

## CAUTION

The torque values in the following table are provided for torquing grade 8 bolts on Liftgate mechanical parts. To prevent damage, never use the information in this table for torquing electrical or hydraulic hose connections on the pump assembly.

GRADE 8 BOLT TIGHTENING TORQUE	
DIAMETER & THREAD PITCH	TORQUE
1/4"-20	10-14 LBS.-FT.
1/4"-28	11-16 LBS.-FT.
5/16"-18	20-29 LBS.-FT.
5/16"-24	22-33 LBS.-FT.
3/8"-16	35-52 LBS.-FT.
3/8"-24	40-59 LBS.-FT.
7/16"-14	56-84 LBS.-FT.
7/16"-20	62-93 LBS.-FT.
1/2"-13	85-128 LBS.-FT.
1/2"-20	96-144 LBS.-FT.
9/16"-12	123-184 LBS.-FT.
9/16"-18	137-206 LBS.-FT.
5/8"-11	170-254 LBS.-FT.
5/8"-18	192-288 LBS.-FT.
3/4"-10	301-451 LBS.-FT.
3/4"-18	336-504 LBS.-FT.

TABLE 88-1

**MAXON**<sup>®</sup>

11921 Slauson Ave. Santa Fe Springs, CA. 90670 (800) 227-4116 FAX (888) 771-7713



THIS PAGE INTENTIONALLY LEFT BLANK

## TROUBLESHOOTING

### PLATFORM WILL NOT RAISE & MOTOR WILL NOT RUN

1. Connect voltmeter between motor solenoid terminal "B" and ground wires connection on pump (FIG. 90-1). Verify that full battery voltage is at "B". Recharge the battery if voltmeter indicates less than 12.6 volts dc.

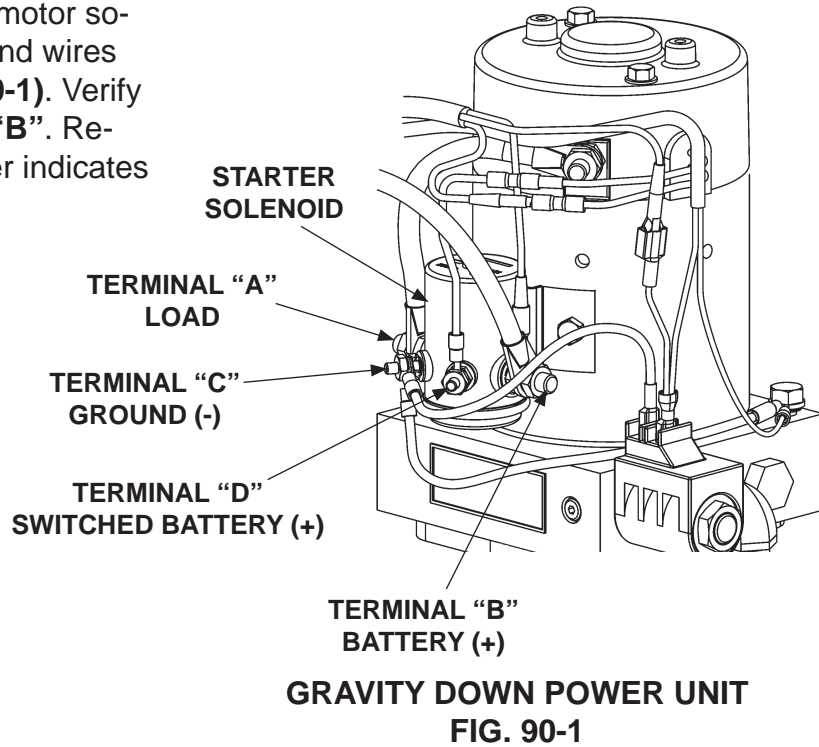

2. Touch a jumper wire to terminals "B" & "D" (FIG. 90-1).  
If motor runs, check control switch, the switch connections, and white wire. Check and correct wiring connections or replace the control switch.
3. Touch heavy jumper cables to terminals "A" & "B" (FIG. 90-1).
  - a. If motor runs, replace the motor solenoid.
  - b. If motor does not run, repair or replace the pump motor.

## PLATFORM WILL NOT RAISE, BUT MOTOR RUNS

1. Do the **CHECKING HYDRAULIC FLUID** procedure in this manual. If necessary, add hydraulic fluid.
2. Check for structural damage and replace worn parts.

### CAUTION

Keep dirt, water and other contaminants from entering the hydraulic system. Before opening the hydraulic fluid reservoir filler cap, drain plug and hydraulic lines, clean up contaminants that can get in the openings. Also, protect the openings from accidental contamination during maintenance.

3. Check pump oil filter in the reservoir (FIGS. 91-1 and 91-2). Clean or replace filter, if necessary.

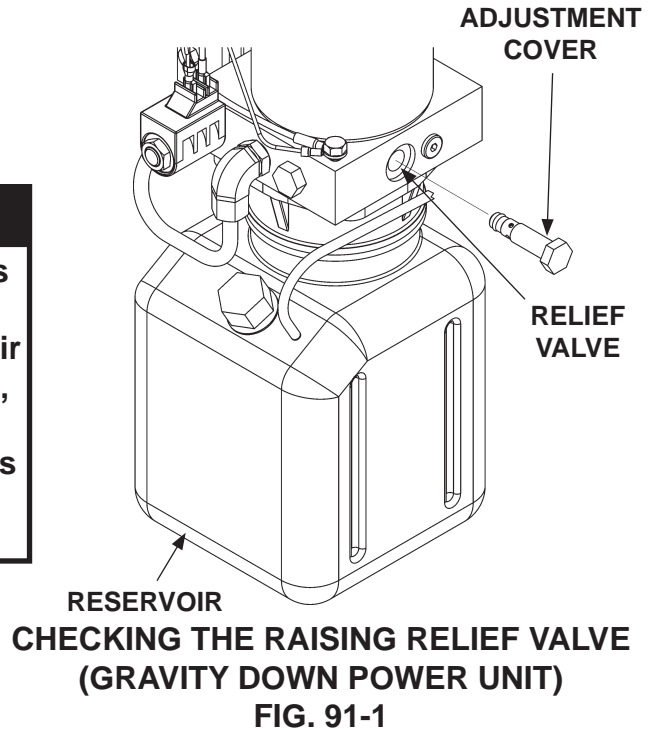

4. Check for dirty raising relief valve (FIGS. 91-1 and 91-2). Clean or replace relief valve if necessary.

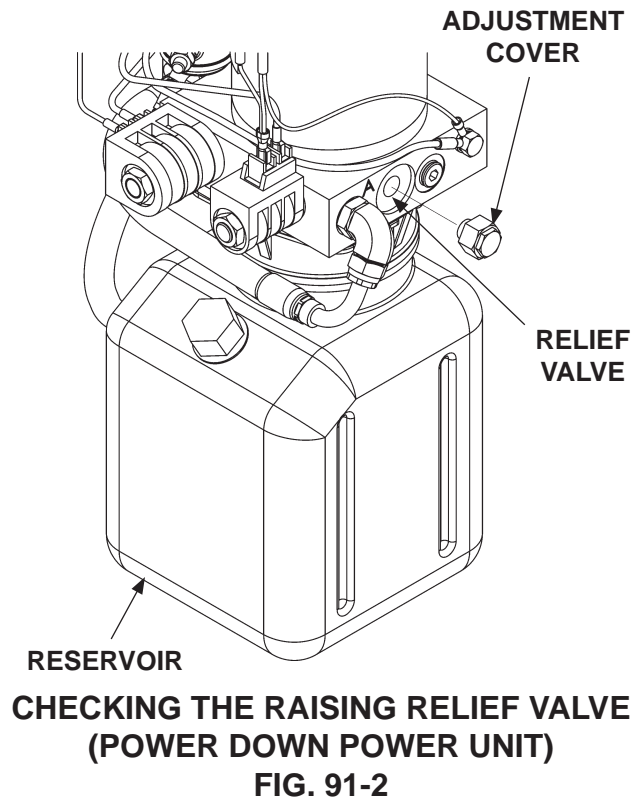

# TROUBLESHOOTING

## PLATFORM RAISES BUT LEAKS DOWN

1. Check if the "A" (lowering) solenoid valve is constantly energized. Connect voltmeter negative (-) lead to ground (-) wires connection on pump and positive (+) lead to (+) terminal on the "A" (lowering) solenoid valve (**FIG. 92-1**). If voltmeter reads battery voltage, check for faulty wiring or toggle switch.

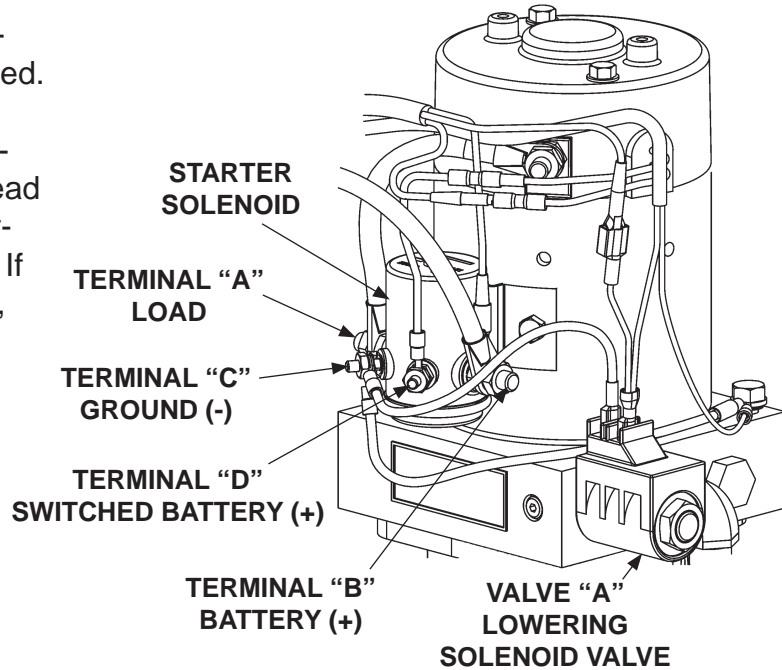

**GRAVITY DOWN POWER UNIT**  
**FIG. 92-1**

**MAXON**

11921 Slauson Ave. Santa Fe Springs, CA. 90670 (800) 227-4116 FAX (888) 771-7713

## CAUTION

Keep dirt, water and other contaminants from entering the hydraulic system. Before opening the hydraulic fluid reservoir filler cap, drain plug and hydraulic lines, clean up contaminants that can get in the openings. Also, protect the openings from accidental contamination during maintenance.

2. Make sure platform is on the ground. Remove lowering solenoid valve (FIGS. 92-1 and 92-2). Push on the plunger in the valve by inserting small screwdriver in the open end (FIG. 92-3). If the plunger does not move with a smooth, spring-loaded action (approximately 1/8"), replace the valve cartridge. **Reinstall lowering solenoid valve. Torque valve cartridge to 30 lbs.-ft. and hex nut to 30 lbs.-in.**

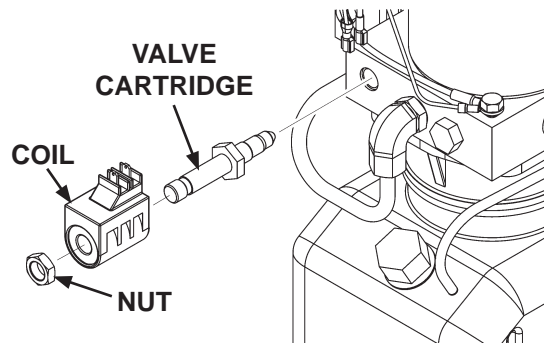

REMOVING SOLENOID VALVE  
(GRAVITY DOWN POWER UNIT)  
FIG. 93-1

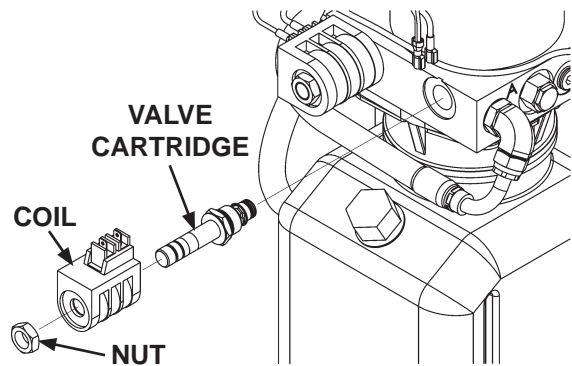

REMOVING SOLENOID VALVE  
(POWER DOWN POWER UNIT)  
FIG. 93-2

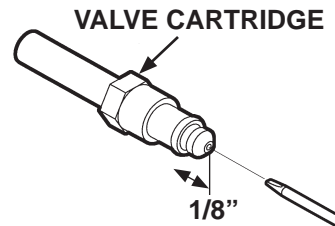

CHECKING SOLENOID VALVE  
FIG. 93-3

3. Check the hydraulic cylinder. With the platform at vehicle floor level, remove the hydraulic line from the **LOWER** port on the cylinder (FIG. 93-1). Hold the control switch in the "**RAISE**" position for two seconds while you watch for hydraulic fluid at the **LOWER** port. A few drops of hydraulic fluid escaping the port is normal. However, if fluid streams out, piston seals are worn. Replace seals.

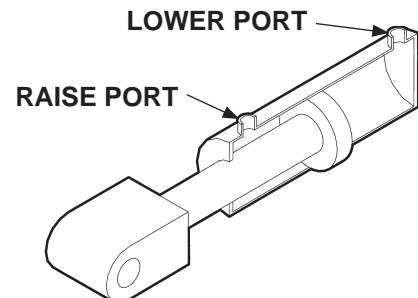
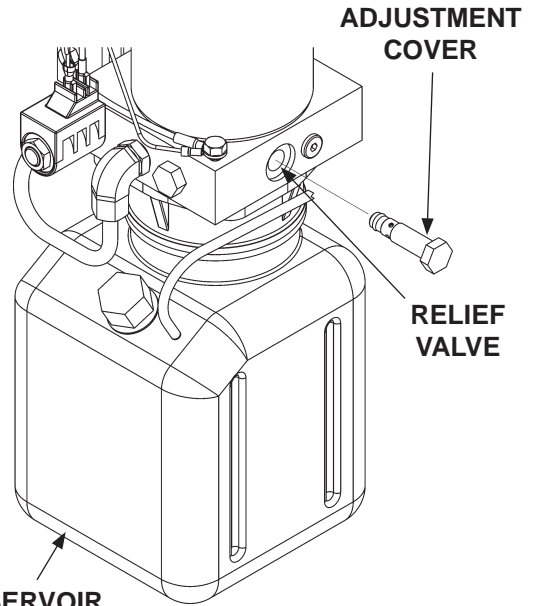

FIG. 93-4

## TROUBLESHOOTING PLATFORM RAISES PARTIALLY AND STOPS

1. Lower the opened platform to the ground. Do the **CHECKING HYDRAULIC FLUID** procedure in this manual. If necessary, add hydraulic fluid.
2. Use voltmeter to verify the battery voltage is 12.6 volts or more under load from pump motor.
3. Check for structural damage and poor lubrication. Replace worn parts.



**RESERVOIR**  
**CHECKING THE RAISING RELIEF VALVE**  
**(GRAVITY DOWN POWER UNIT)**  
**FIG. 94-1**

**CAUTION**

Keep dirt, water and other contaminants from entering the hydraulic system. Before opening the hydraulic fluid reservoir filler cap, drain plug and hydraulic lines, clean up contaminants that can get in the openings. Also, protect the openings from accidental contamination during maintenance.

4. Check for dirty raising relief valve (**FIGS. 94-1 and 94-2**). Clean or replace relief valve, if necessary.

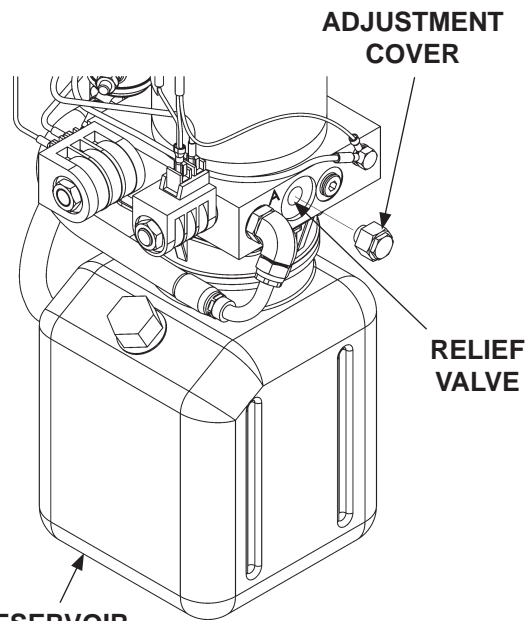

**RESERVOIR**  
**CHECKING THE RAISING RELIEF VALVE**  
**(POWER DOWN POWER UNIT)**  
**FIG. 94-2**

5. Check the hydraulic cylinder. With the platform at vehicle floor level, remove the hydraulic line from the **LOWER** port on the cylinder (**FIG. 95-1**). Hold the control switch in the “**RAISE**” position for two seconds while you watch for hydraulic fluid at the **LOWER** port. A few drops of hydraulic fluid escaping the port is normal. However, if fluid streams out, piston seals are worn. Replace seals.

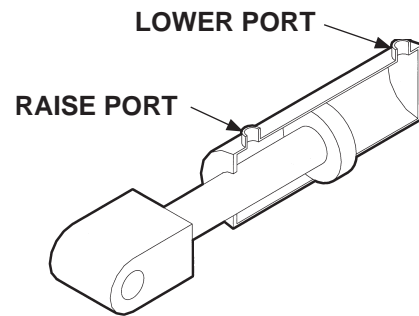

**FIG. 95-1**

6. Check pump oil filter in the reservoir (**FIGS. 94-1 and 94-2**). Clean or replace filter, if necessary.

# TROUBLESHOOTING

## LIFTGATE WILL NOT LIFT RATED CAPACITY

1. Use voltmeter to verify the battery voltage is 12.6 volts or more under load from pump motor.
2. Check for structural damage or lack of lubrication. Replace worn parts.

**CAUTION**

Keep dirt, water and other contaminants from entering the hydraulic system. Before opening the hydraulic fluid reservoir filler cap, drain plug and hydraulic lines, clean up contaminants that can get in the openings. Also, protect the openings from accidental contamination during maintenance.

3. Check the 3200 PSI relief valve as follows. With platform on the ground, remove plug from hand pump port (**FIGS. 96-1 and 96-2**). Install 0-4000 PSI pressure gauge in the hand pump port (**FIGS. 96-1 and 96-2**). Remove cover for access to relief valve. Hold the control switch in the “**RAISE**” position. Adjust the relief valve until the gauge reads 3200 PSI (**FIGS. 96-1 and 96-2**). Remove gauge and reinstall plug in the port. Then, reinstall relief valve cover.
4. Check if pump relief valve is dirty. Clean or replace relief valve, if necessary.

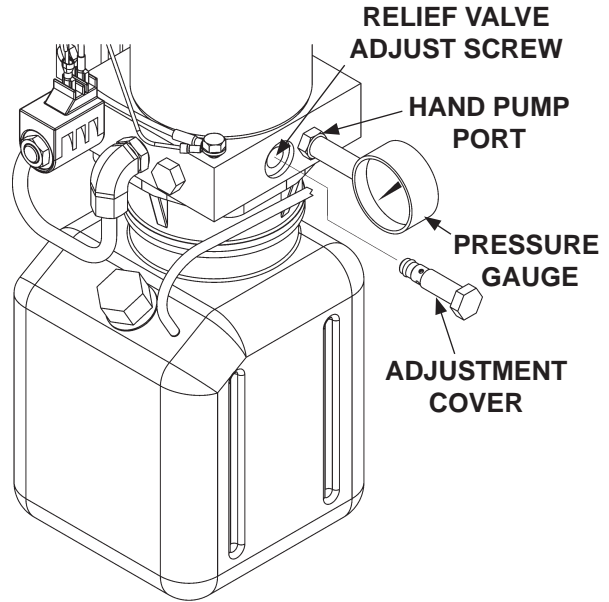

**ADJUSTING RAISING RELIEF VALVE  
(GRAVITY DOWN POWER UNIT)  
FIG. 96-1**

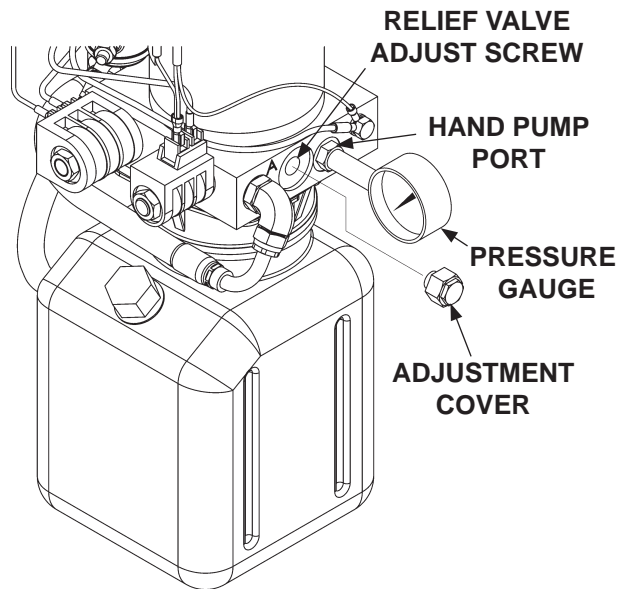

**ADJUSTING RAISING RELIEF VALVE  
(POWER DOWN POWER UNIT)  
FIG. 96-2**



5. Check the hydraulic cylinder. With the platform at vehicle floor level, remove the hydraulic line from the **LOWER** port on the cylinder (**FIG. 97-1**). Hold the control switch in the “**RAISE**” position for two seconds while you watch for hydraulic fluid at the **LOWER** port. A few drops of hydraulic fluid escaping the port is normal. However, if fluid streams out, piston seals are worn. Replace seals.
  
6. If pump cannot produce 3200 PSI or lift the load capacity with a minimum of 12.6 volts available, the pump is worn and needs to be replaced.

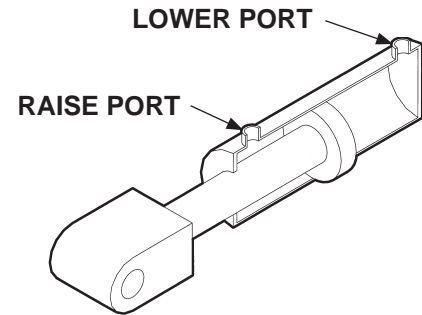

**FIG. 97-1**

# TROUBLESHOOTING

## PLATFORM WILL NOT LOWER, LOWERS TOO SLOWLY, OR TOO QUICKLY

1. Connect voltmeter (+) lead to motor solenoid terminal “B” and the (-) lead to the ground wires connection on pump (FIG. 98-1). Verify that full battery voltage is at “B”. Recharge the battery if voltmeter indicates less than 12.6 volts dc.

2. Check for structural damage or poor lubrication. Replace worn parts.

3. Check if the “D” terminal and “A” (lowering) solenoid valve are getting battery voltage (FIG. 98-1). Connect voltmeter negative (-) lead to ground (-) wires connection on pump and positive (+) lead to the “D” terminal (FIG. 98-1). Hold control switch in the “LOWER” position. Then, connect voltmeter (+) lead to (+) terminal on the “A” (lowering) solenoid valve (FIG. 98-1). If voltmeter shows a much lower reading than +12.6 volts dc or a reading of 0 volts, check for faulty control switch and wiring, battery cable, ground wire connections in pump assembly, and pump motor.

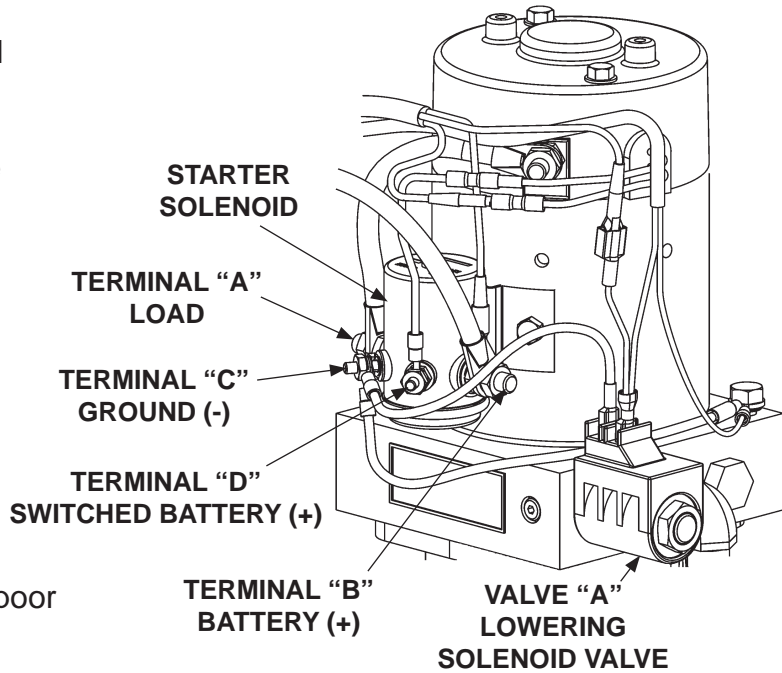

**GRAVITY DOWN POWER UNIT  
FIG. 98-1**

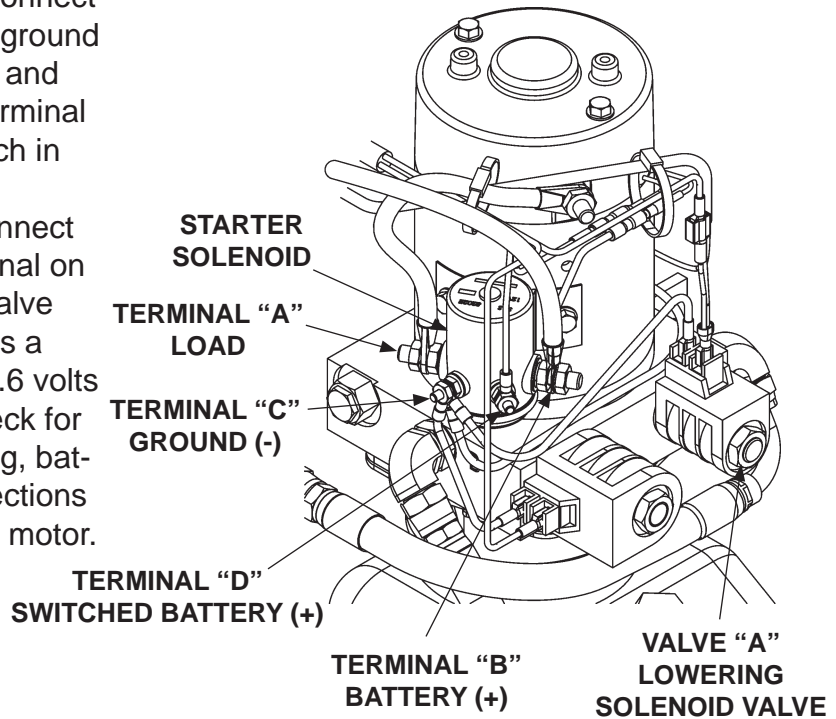

**POWER DOWN POWER UNIT  
FIG. 98-2**

**MAXON**

11921 Slauson Ave. Santa Fe Springs, CA. 90670 (800) 227-4116 FAX (888) 771-7713

## CAUTION

Keep dirt, water and other contaminants from entering the hydraulic system. Before opening the hydraulic fluid reservoir filler cap, drain plug and hydraulic lines, clean up contaminants that can get in the openings. Also, protect the openings from accidental contamination during maintenance.

## CAUTION

To prevent damage to flow control valve, do not disassemble the valve.

4. Make sure platform is on the ground. Check the flow control valve as follows. Remove flow control valve (**FIG. 99-1**). Ensure the flow control valve operates with a smooth spring-loaded action. Check for debris inside the valve. Clean or replace the flow control valve, if necessary. Reinstall flow control valve (if good) or a replacement.

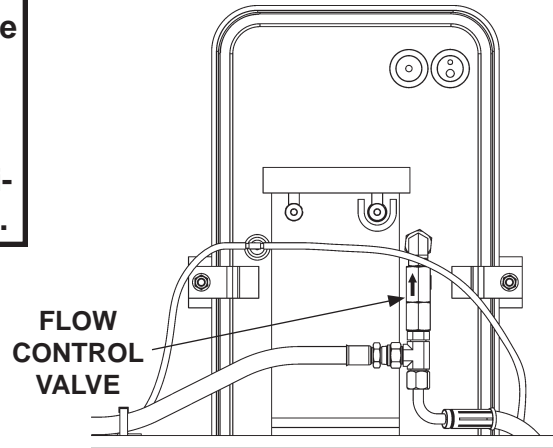

**FLOW CONTROL VALVE ON BACK OF GRAVITY DOWN PUMP ASSEMBLY**  
**FIG. 99-1**

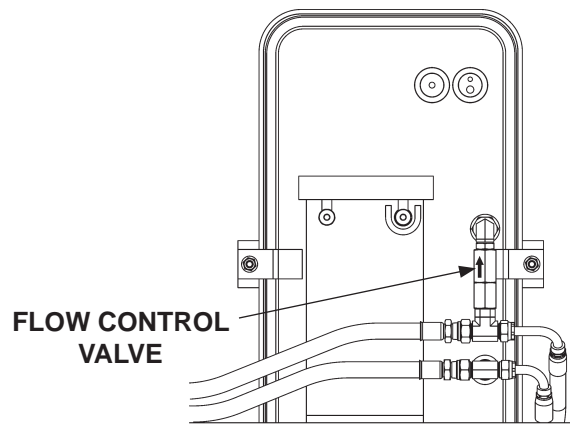

**FLOW CONTROL VALVE ON BACK OF POWER DOWN PUMP ASSEMBLY**  
**FIG. 99-2**

5. Check the lowering solenoid valve as follows. Check if filtering screen is plugged. Clean carefully if required. Push on the plunger in the valve by inserting small screwdriver in the open end (**FIG. 99-3**). If the plunger does not move with a smooth, spring-loaded action (approximately 1/8"), replace the valve cartridge. **Reinstall lowering solenoid valve** (if good) or a replacement. **Torque valve cartridge to 30 lbs.-ft. and hex nut to 30 lbs.-in.**

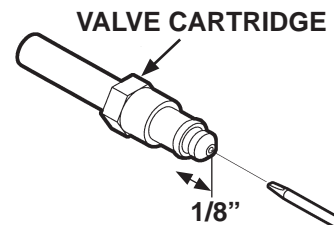

**CHECKING SOLENOID VALVE**  
**FIG. 99-3**

