

M-90-1
REV. C
MAR. 2000

MAXON[®]

INSTALLATION MANUAL

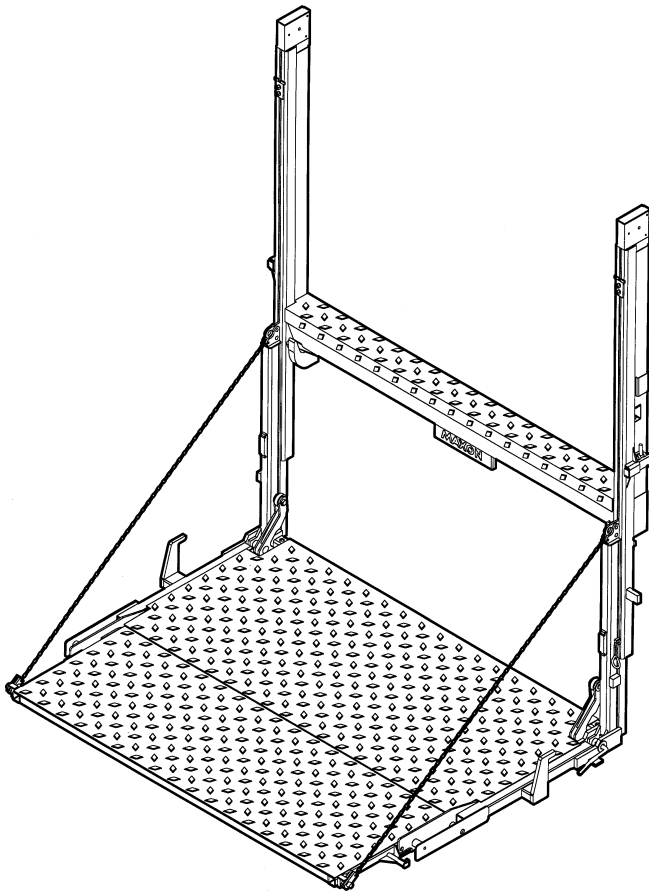

RC-2B

RC-3B

RC-4B

RC-5B

RC-6B

RC-6K

MAXON[®]

11921 Slauson Avenue.
Santa Fe Springs, CA. 90670
(800) 227-4116

MAXON[®]

LIFT CORP.

11921 Slauson Ave.
Santa Fe Springs, CA. 90670

CUSTOMER SERVICE:

(562) 464-0099

(800) 227-4116

FAX: (888) 771-7713

TECHNICAL SERVICE:

(800) 8-MAXTEK (862-9835)

NOTE: Check with Customer Service Department for updated versions of Manuals on an annual basis.

WARRANTY POLICY & PROCEDURE

NEW LIFTGATE WARRANTY

Term of Warranty: 2 Years from Date of In-Service

Type of Warranty: Full Parts and Labor

MAXON agrees to replace any components which are found to be defective during the first 2 years of service, and will reimburse for labor based on MAXON's Liftgate Warranty Flat Rate Labor Schedule. (Call MAXON Customer Service for a copy).

All claims for warranty must be received within 30 Days of the repair date, and include the following information:

1. Liftgate Model Number
2. Liftgate Serial Number
3. Description of Problem
4. Corrective Action Taken, and Date of Repair.
5. Parts used for Repair, Including MAXON Part Number(s).
6. MAXON R.G.A. # and/or Authorization # if applicable (see below).
7. Person contacted at MAXON if applicable.

PURCHASE PART WARRANTY

Term of Warranty: 1 Year from Date of Purchase Type of Warranty: Part Replacement and Replacement Labor.

MAXON will guarantee all returned genuine replacement parts upon receipt, and inspection of parts and invoice. All Warranty repairs must be performed by an authorized MAXON warranty station.

For major repairs, MAXON's Warranty Department must be notified, and an "Authorization Number" received. Major repairs would generally be considered repairs made to the structural assembly of the liftgate and/or repairs not outlined in the MAXON Liftgate Warranty Flat Rate Schedule.

Major components (i.e. hydraulic pumps, cylinders, valves, or failed structural parts) must be returned, freight pre-paid, prior to the claim being processed. To ensure timely processing of these warranty claims, an R.G.A. (Returned Goods Authorization) number must be obtained from MAXON's Warranty Department prior to the return of any defective part. Defective Parts must be returned within 60 days of the claim date for consideration to:

**Warranty Department, MAXON Lift Corp.
5920 Alameda St., Huntington Park, CA. 90255**

MAXON's warranty policy does not include the reimbursement for travel time; towing; vehicle rental; service calls; fabrication of parts which are available from MAXON; oil; defects due to misuse or abuse; loss of income due to downtime.

MAXON's Flat Rate Labor Schedule times takes into consideration time required for diagnosis of problem.

Warranty and Technical Information is available by calling MAXON's Customer Service Department.

Table of Contents

INTRODUCTION.....	PAGE 4
UNIT AS SHIPPED.....	PAGE 5
INSTALLATION OF UNIT	PAGE 6
WELDING TO FLATBED.....	PAGE 11
HYDRAULIC PIPE INSTALLATION	PAGE 12
POWER PACK INSTALLATION	PAGE 13
FUSED POWER CABLE.....	PAGE 16
PUMP WIRING CAM CLOSER.....	PAGE 17
PUMP WIRING HYDRAULIC CLOSER	PAGE 18
FINAL ADJUSTMENTS	PAGE 19
OPTIONAL INSTALLATIONS.....	PAGE 21
RCT LIGHT INSTALLATION	PAGE 22
HAND PUMP OPTION FOR CAM CLOSER.....	PAGE 24
BATTERY PAK INSTALLATION (For Trailers).....	PAGE 25
TRACTOR TO TRAILER CONNECTION.....	PAGE 26
INSTALLING POWER CABLE CONNECTOR (For Trailers)	PAGE 27
BATTERY CABLE MOUNTING, 6 VOLT SYSTEM	PAGE 28
BATTERY CABLE MOUNTING, 12 VOLT SYSTEM	PAGE 29
FIXED RAMP INSTALLATION, 6"	PAGE 30
FIXED RAMP INSTALLATION, 12"	PAGE 31
CART STOP & DUAL CART STOP RAMP INSTALLATION	PAGE 32
HINGED RAMP INSTALLATION (STEEL)	PAGE 33
HINGED RAMP INSTALLATION (ALUMINUM)	PAGE 34

INTRODUCTION

This publication contains the information required to install the following models and their options; **RC, RCW, RCT, RC-CL, and RCHL** from 2000 to 6000 pound capacities. If there is any doubt in your mind regarding the suitability of these lifts being installed on its intended vehicle, or any portion of these instructions that you do not understand, please contact the Maxon Customer Service Department for consultation.

Unauthorized modification to this equipment may cause premature failure or create hazards in its use that are not foreseen at the time of the installation. These kinds of changes should be discussed with our Engineering Department before being undertaken.

Bed height requirements to ground are 38" laden to 56" unladen.

These lifts cannot be installed on bodies with swing type doors.

These lifts have been designed to fit bodies that are 96" wide, (102" wide, in the case of the RCW Models). If this body has dimensions that are much different than these, special brackets will have to be fabricated for attachment. The corner posts of the body must also be made of steel so that the lift columns can be welded to it. If they are aluminum, then steel plates will have to be fabricated to bolt to these corner posts for welding to the lift assembly. Both of the above conditions are rare and therefore have not been provided for in this manual. Contact the Customer Service Department if either of the above conditions exist.

UNIT AS SHIPPED

Do not remove stands at bottom of column until instructed to do so.

Steel box containing pump assembly, also contains a packing list, instruction manuals, decals, and all necessary hardware to complete installation.

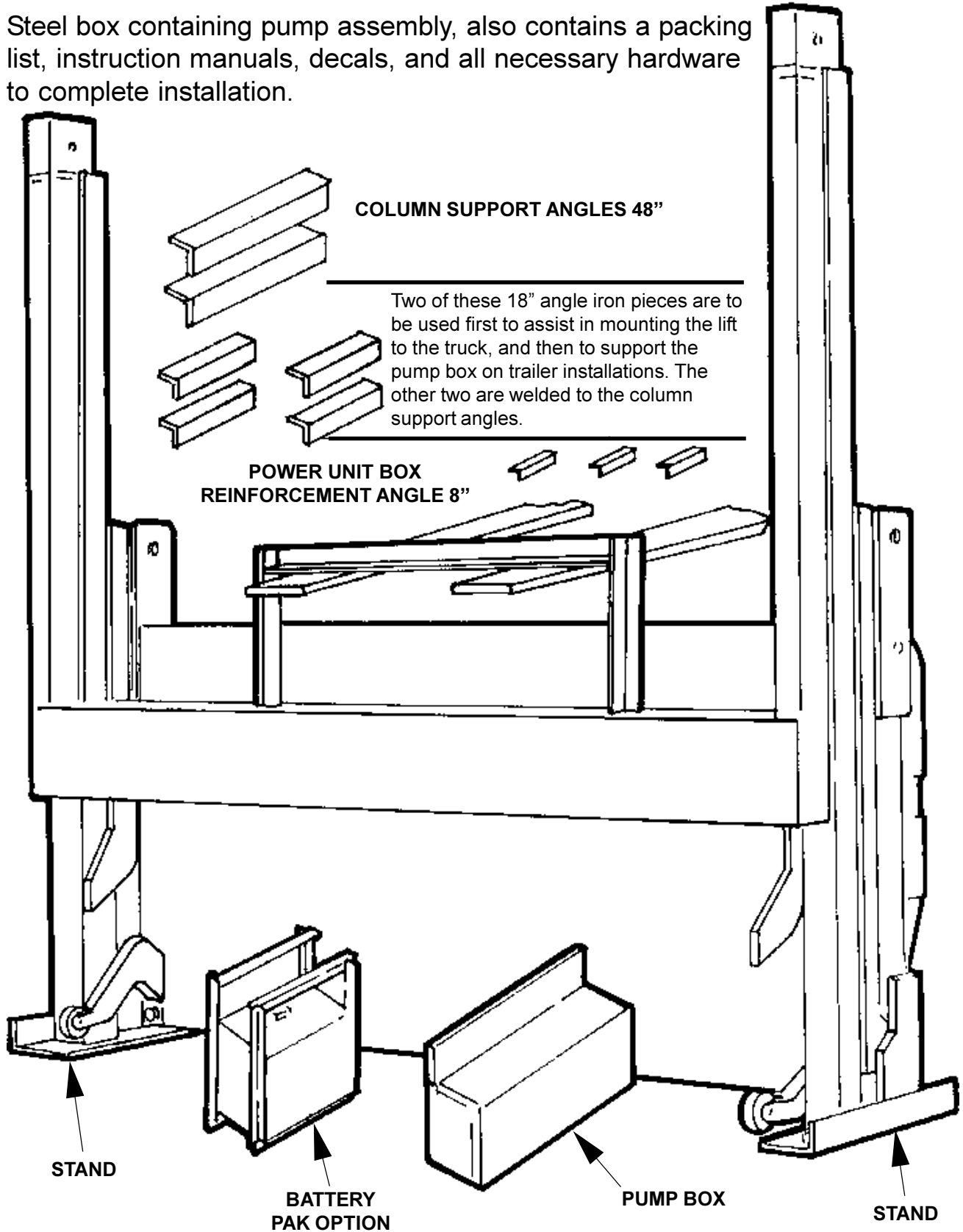

INSTALLATION OF UNIT

There are two pieces of angle iron supports (2-1/2 x 2-1/2 x 18") that have been provided to assist in lining the unit up to the body. Tack weld them to the top of the lift's main section, just strong enough to support it on the truck floor till the lift is secured and ready to weld. Put a chalk mark on the center of the unit (on the thread plate surface) for aligning with the center of the truck body.

Remove support angles after lift is mounted and use them for pump box mount reinforcement.

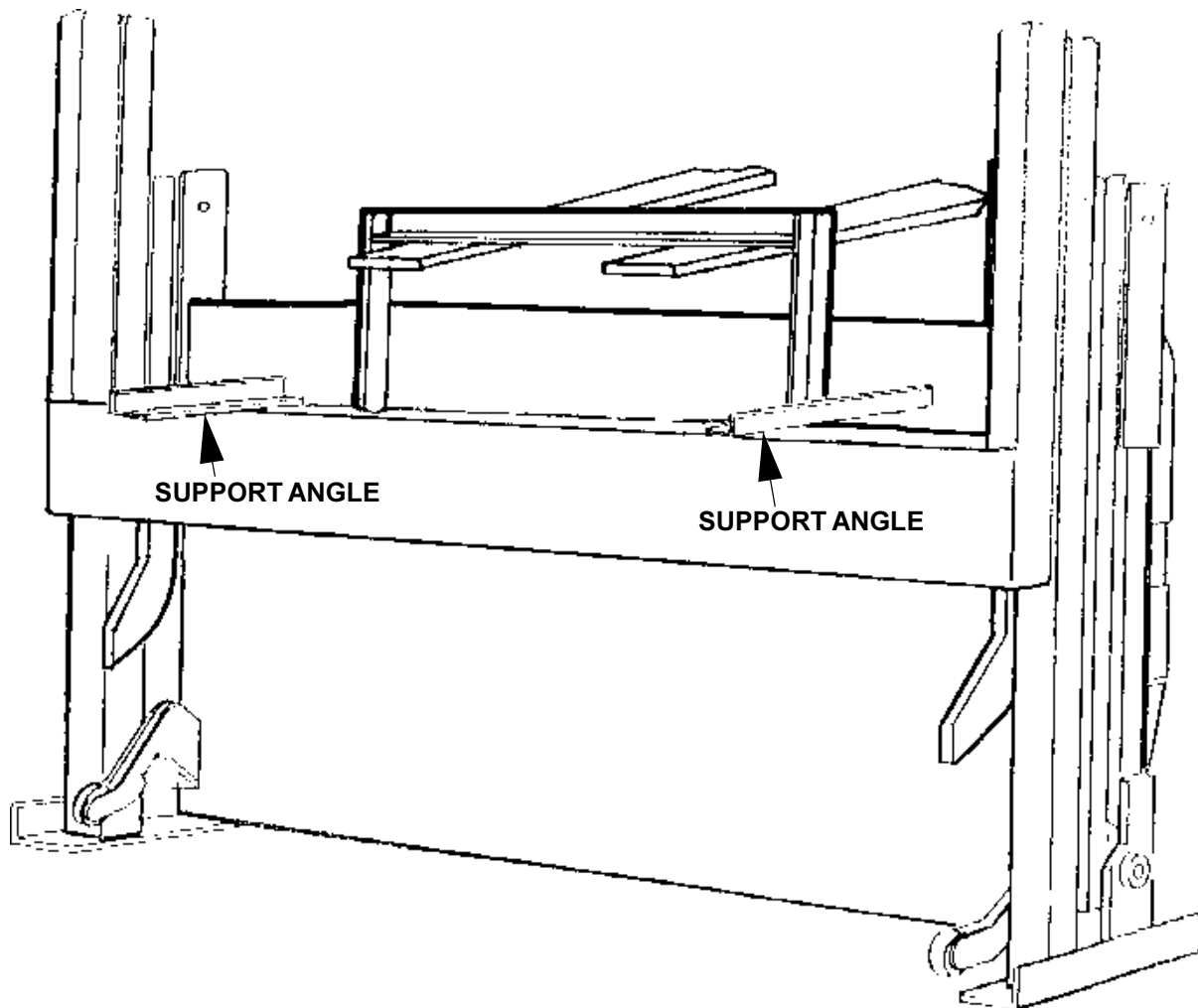

MAXON[®]

11921 Slauson Ave. Santa Fe Springs, CA. 90670 (800) 227-4116 FAX (888) 771-7713

INSTALLATION OF UNIT

Corner posts and sill under rear of floor must be clean and free of any obstructions so that the columns of the rail lift can fit flat against the rear of the body.

Chalk mark a center line at the edge of the rear of the truck floor to line up with the mark on the liftgate.

Using the lifting straps, the unit can now be raised either with a chain hoist or fork lift to a height which will allow the temporary support angles to rest on the body floor. The unit can be moved to the vehicle or the vehicle to the unit till they meet.

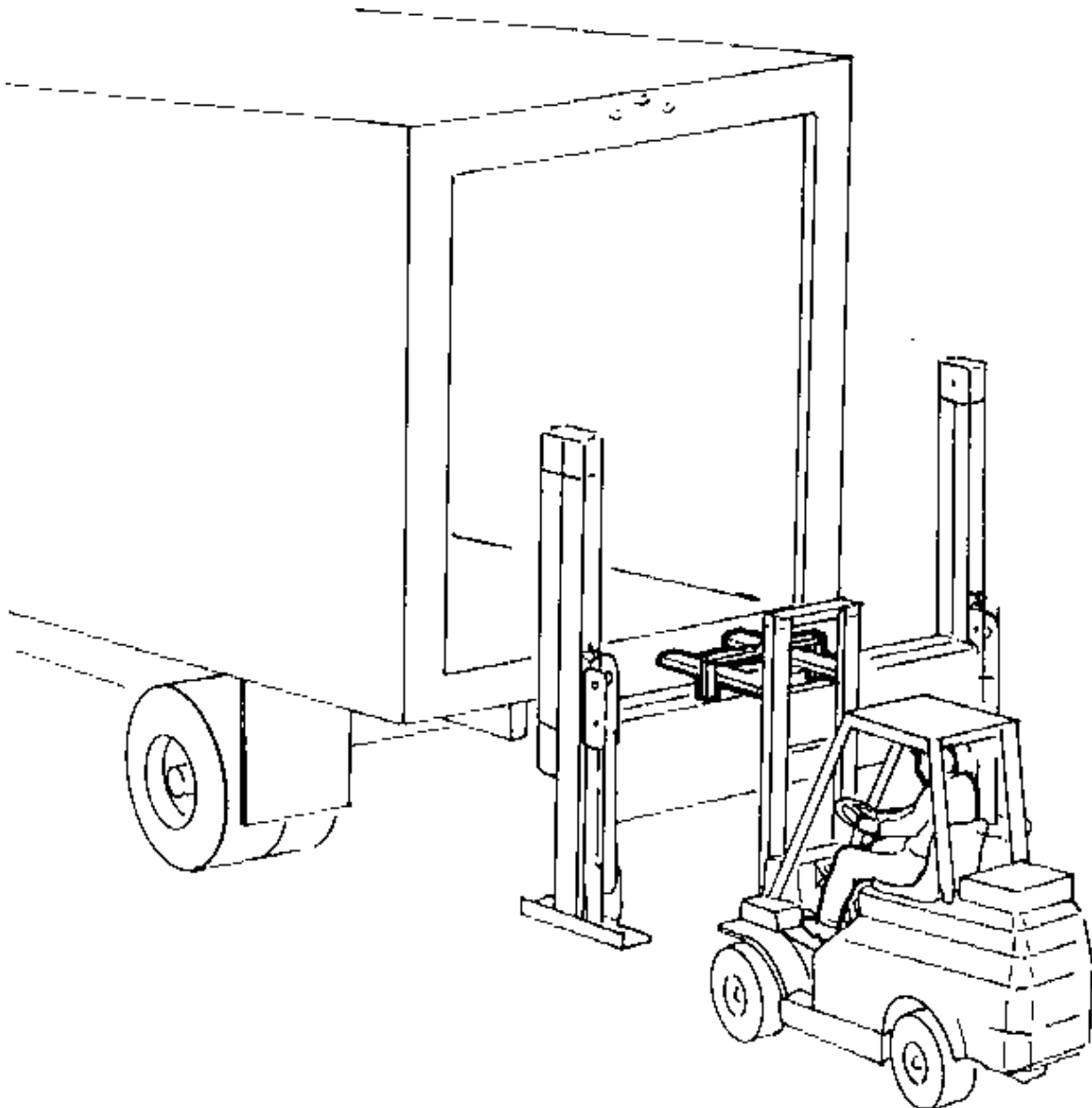

INSTALLATION OF UNIT

Clamp columns to the truck body and weld as shown. Remove forklift or chain hoist.

RC-2000/3000/RC-CR3

1/4" Fillet Weld. 2" Long

RC-4000

1/4" Fillet Weld. 3" Long

RC-5000/6000

1/4" Fillet Weld. 4" Long

NOTE: See views A & B on next page.

ALL UNITS: 1/8" fillet weld
approx. halfway
down the column.

ALL UNITS: See view C on
the next page.

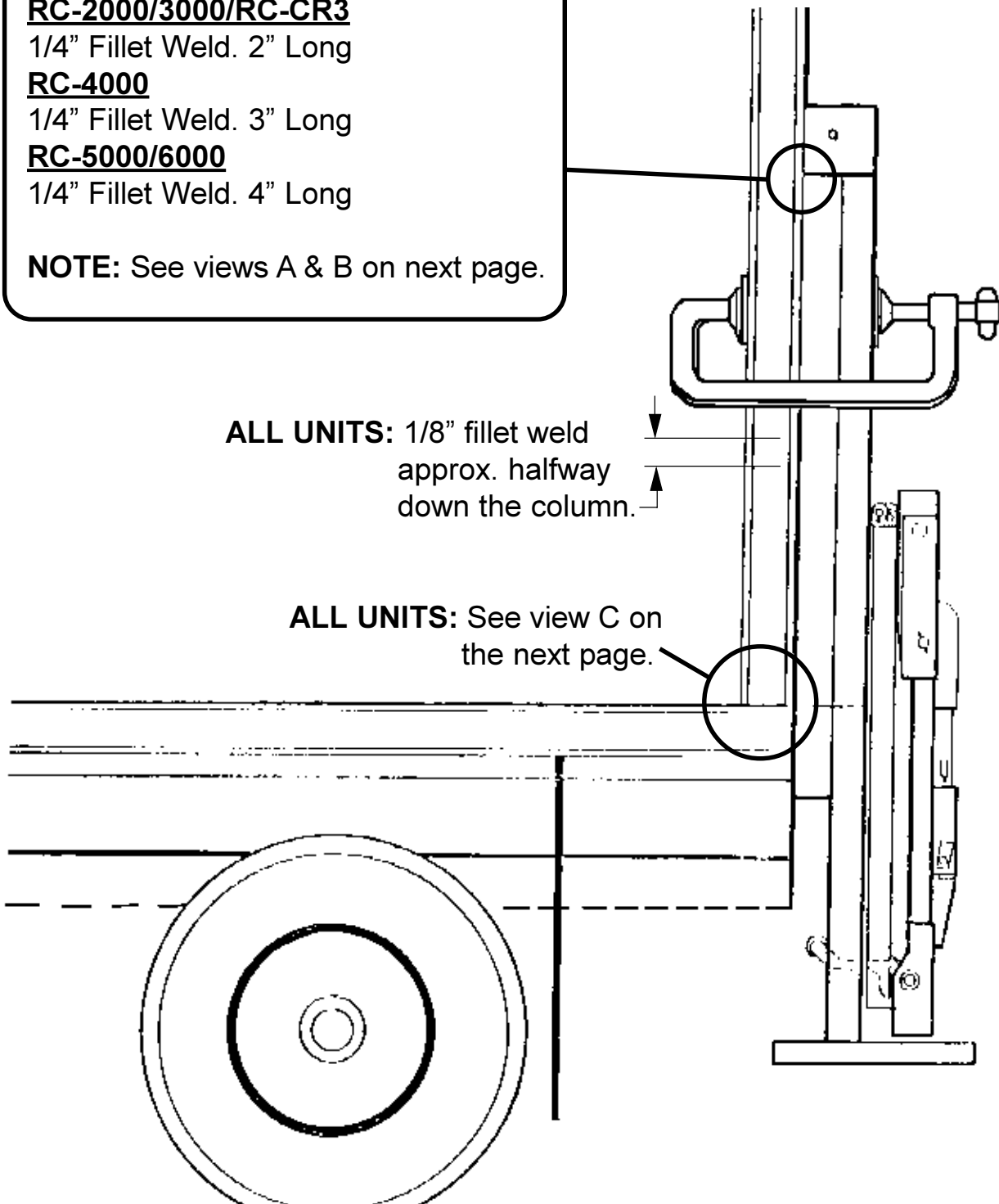

MAXON[®]

11921 Slauson Ave. Santa Fe Springs, CA. 90670 (800) 227-4116 FAX (888) 771-7713

INSTALLATION OF UNIT

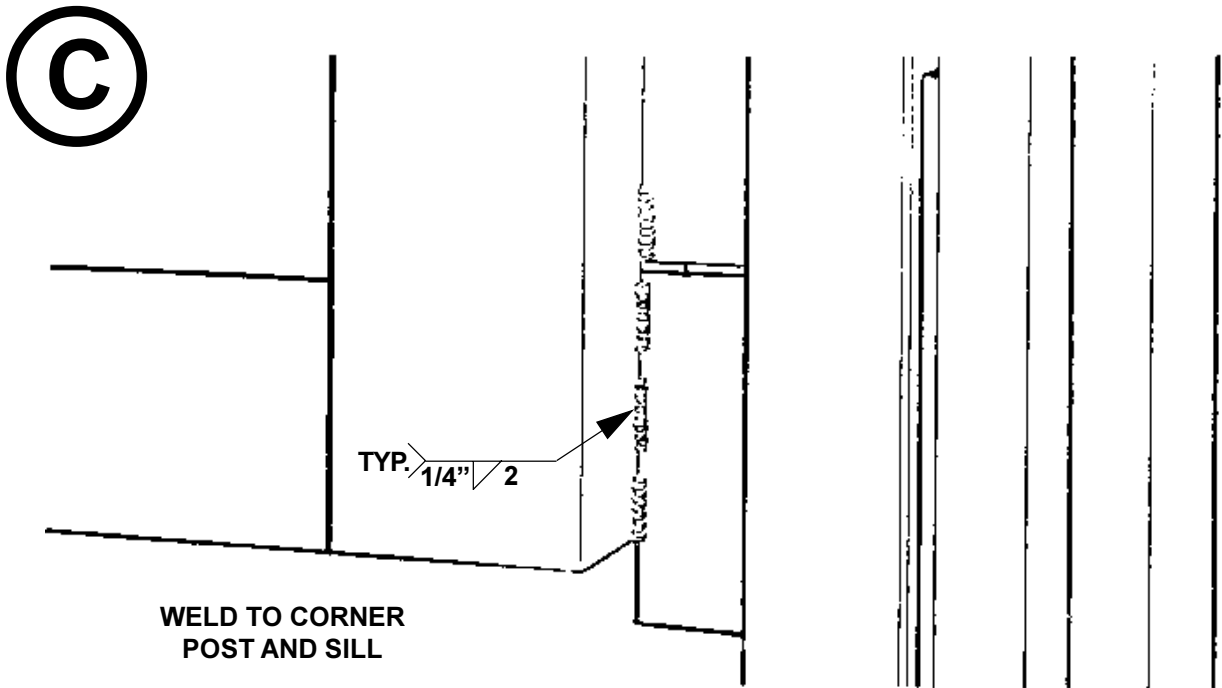
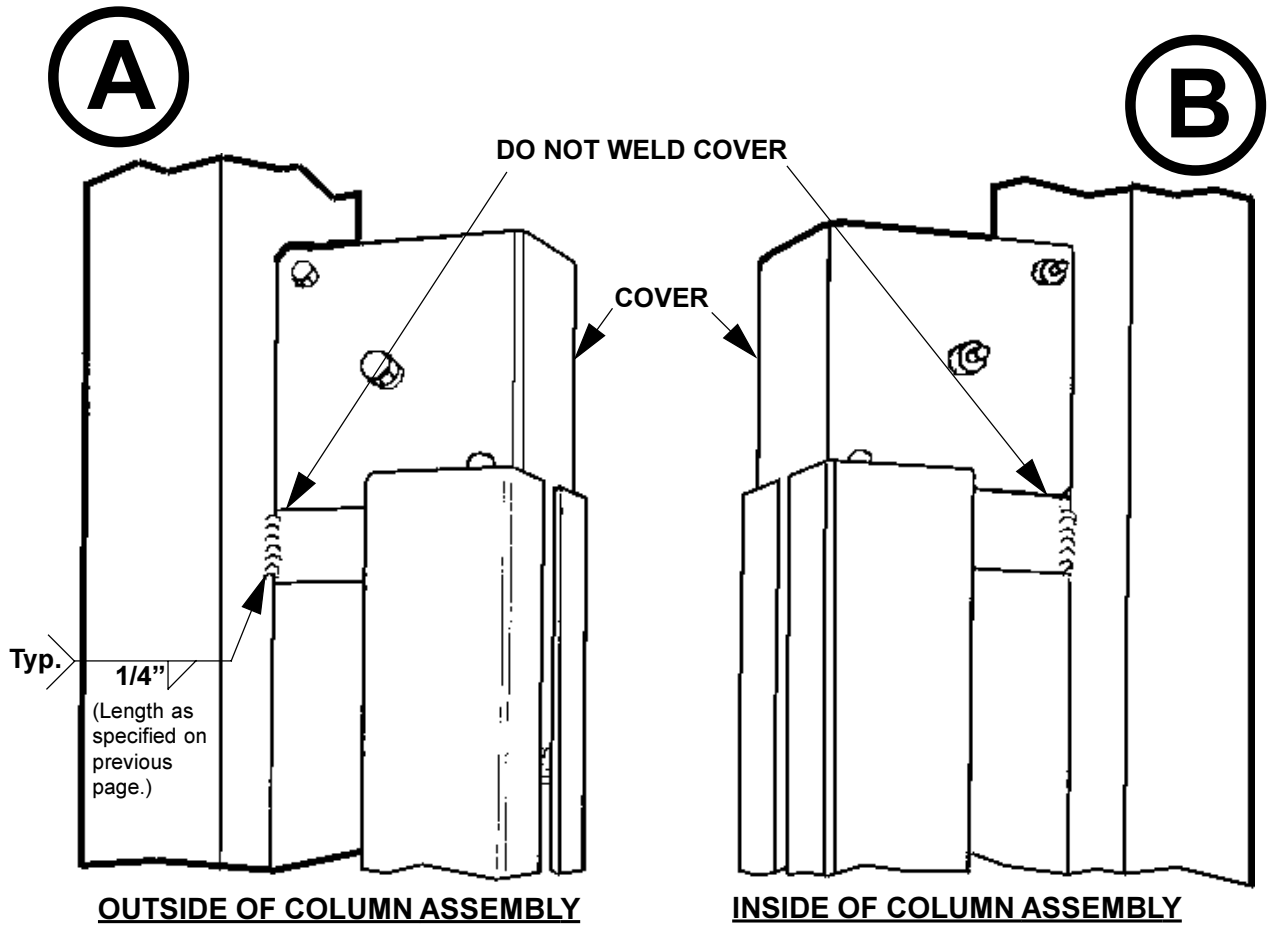

BOTTOM CORNER OF TRUCK BODY

INSTALLATION OF UNIT

Cut columns off 20" from ground. Place the 2-1/2" x 18" angle iron provided under at least 2 cross members, to prepare for the following step and weld.

Cut one end of each of the 4 foot long angle iron braces so that it lines up with the lift column and the other end lays flat against the angle iron referred to in the previous paragraph.

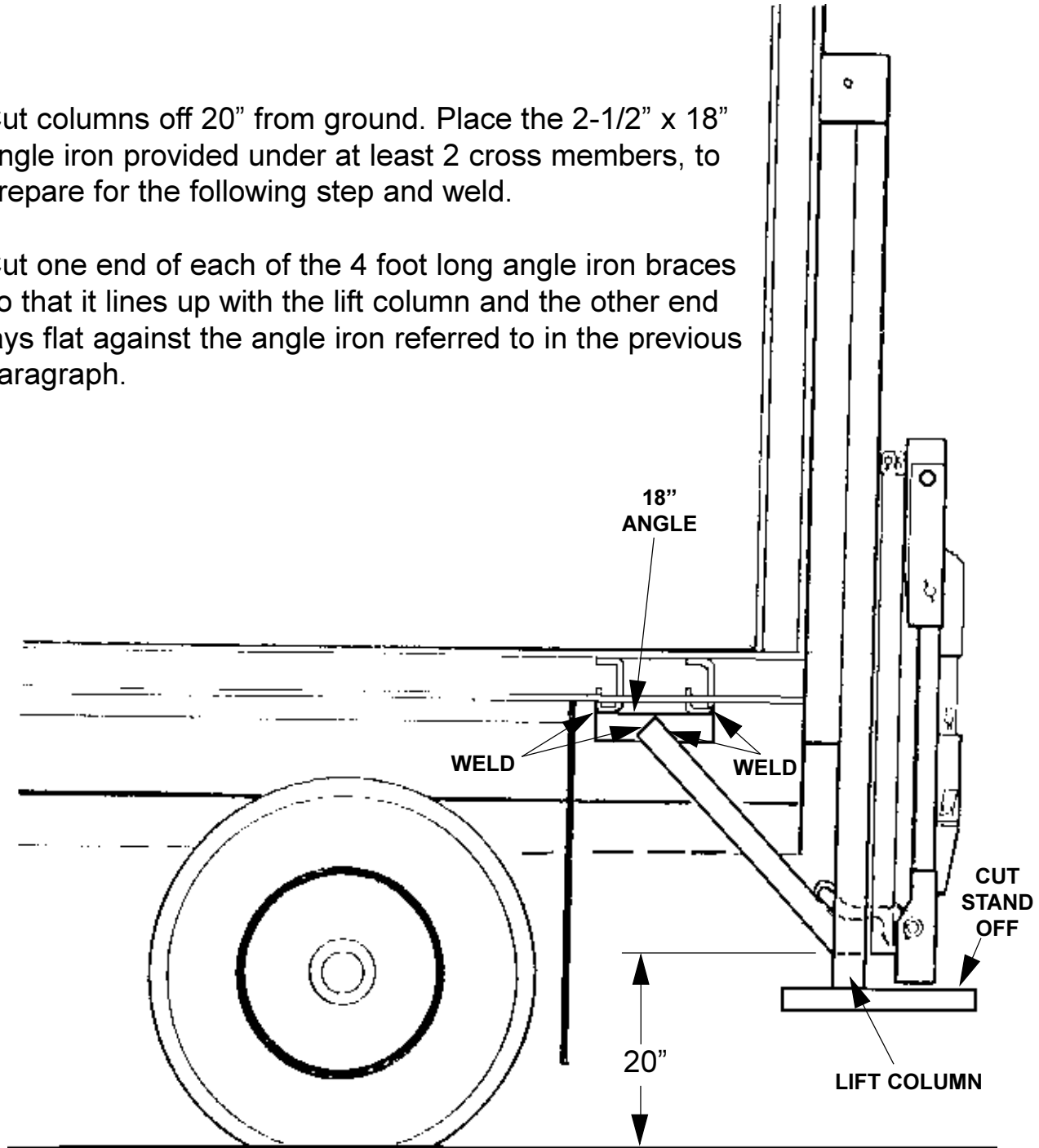

WELDING TO FLATBED

The column assemblies are tied in to the flat bed side rails with two lengths of channel. The required sizes are listed below.

RC-2000/3000/4000

3" of 1/4" fillet weld

RC-5000/6000

4" of 1/4" fillet weld

NOTE: Mounting Channel is not supplied by Maxon

RC-2000/3000/4000

3"-4.1 #/ft. Channel

RC-5000/6000

4"-5.4 #/ft. Channel

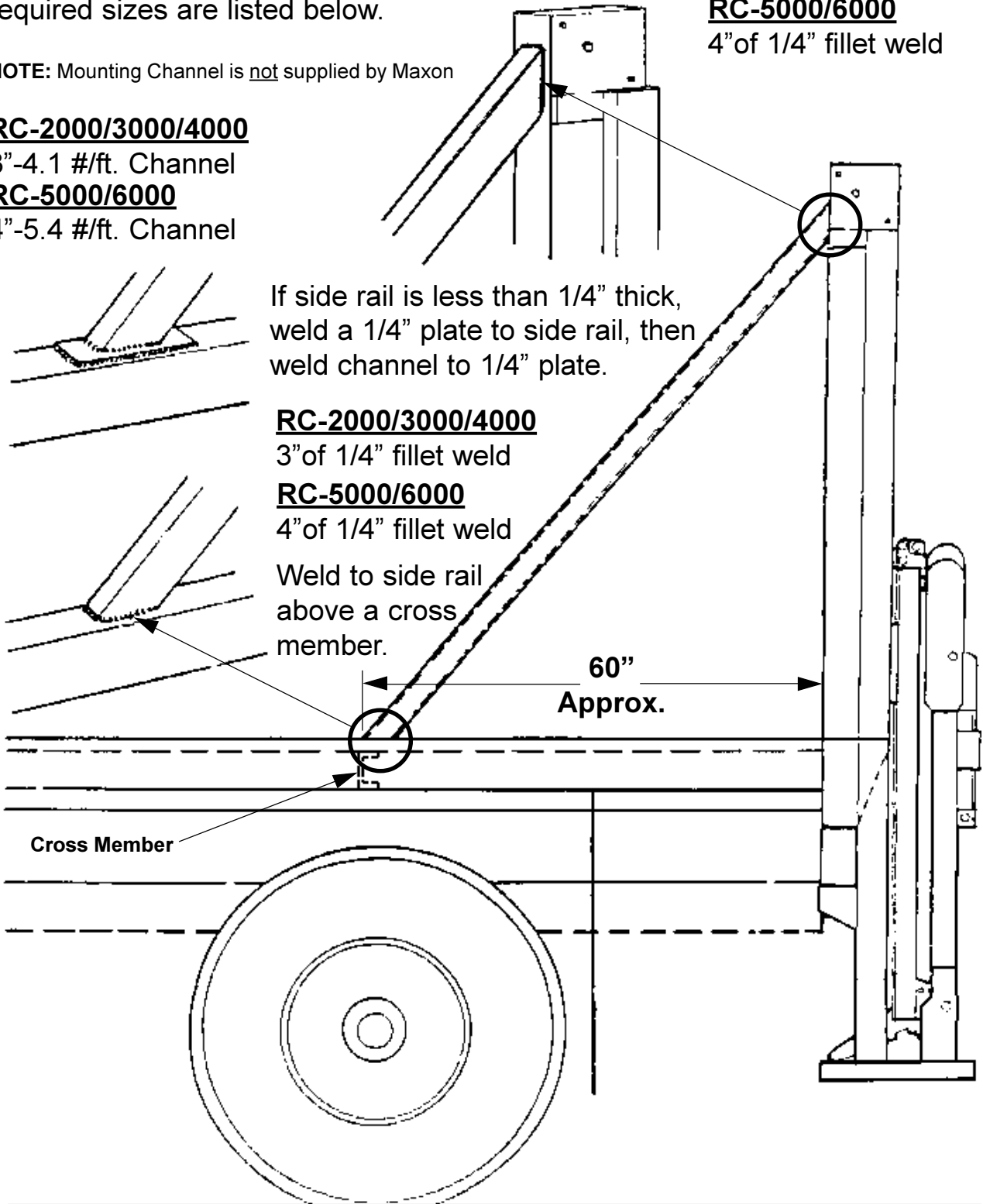

HYDRAULIC PIPE INSTALLATION

Remove the seven foot long pipe that is strapped to this column of the lift gate (two pipes if lift has hydraulic platform closer), and weld to under side of floor cross members. End of pipe to be about two feet from the end of the truck body. Connect the four foot hoses to the end of the pipe(s) closest to the power unit and the other end through the pump box to the pump assembly. See the last page of "Power Pak Installation" for details.

NOTE: Blow air through pipes and hoses before connections are made.

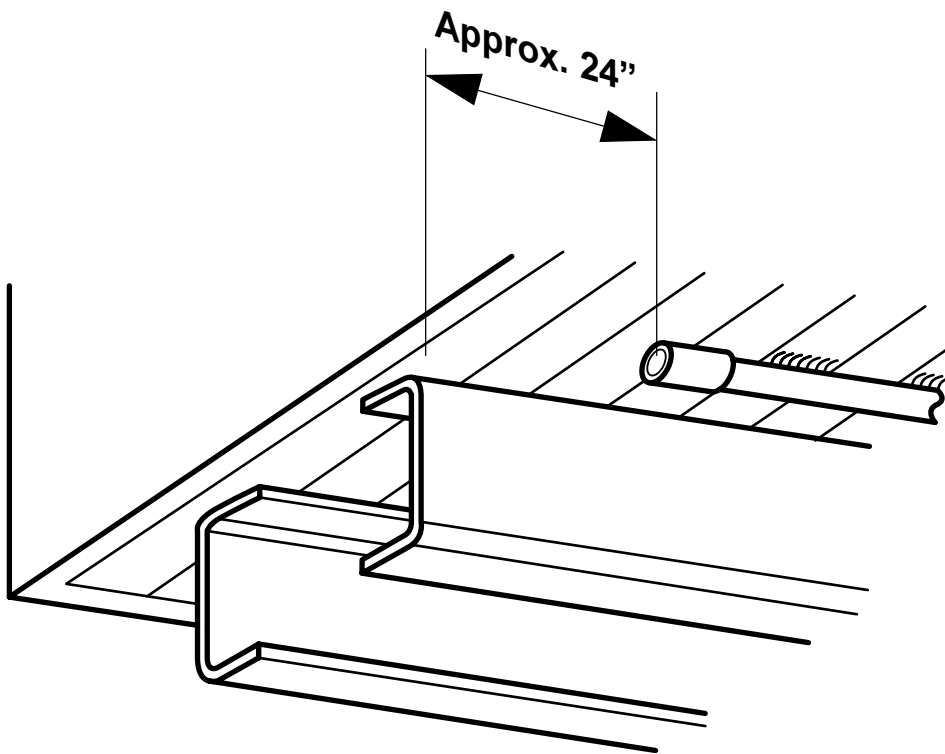

MAXON

11921 Slauson Ave. Santa Fe Springs, CA. 90670 (800) 227-4116 FAX (888) 771-7713

POWER PACK INSTALLATION

TRUCK BODIES

Jack up the steel box containing the pump assembly until it touches at least two cross members under the floor, three if possible, and the back of the box touches the truck chassis frame. Weld where instructed and remove jack. Leave room for tail lights.

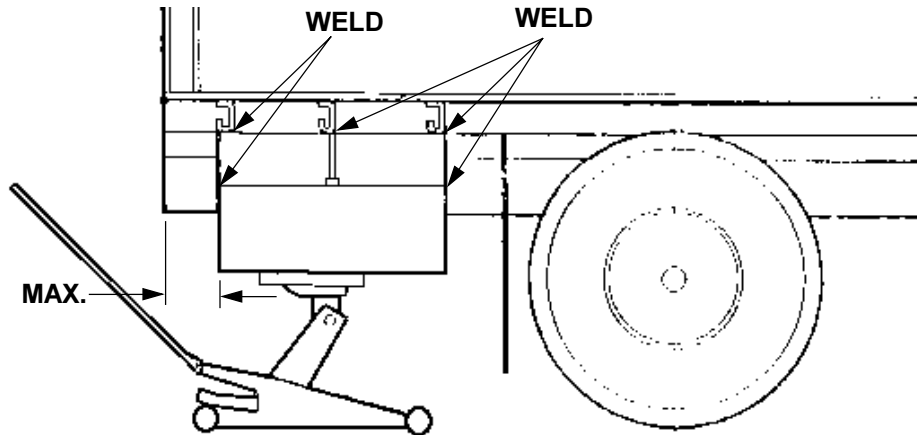

TRAILER BODIES

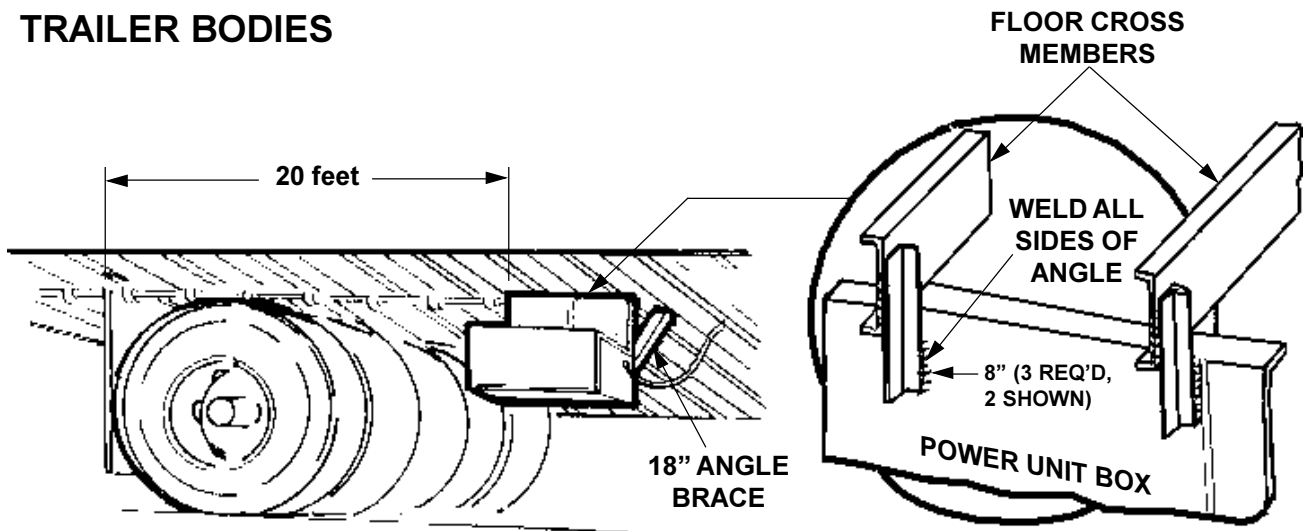

Jack up the steel box containing the pump assembly until it touches at least two cross members under the floor, three if possible and tack weld. Add braces provided to the back of the box and the side of the floor cross members. Weld both ends of braces and top of box. Use short pieces of angle iron provided to weld from the side of the floor cross members to the front of the box.

Make sure the box is not in a position to interfere with the wheels of the trailer with sliding axle.

Box can also be placed behind the wheels if room permits.

POWER PACK INSTALLATION

Run 32 ft. power cable from the pump box, along the chassis frame to the positive terminal of the battery (assuming the negative is ground). Use frame clips to secure the cable. (Do not attach to the battery terminal until the other end is fastened on the pump). If the cable is too long, cut to proper length.

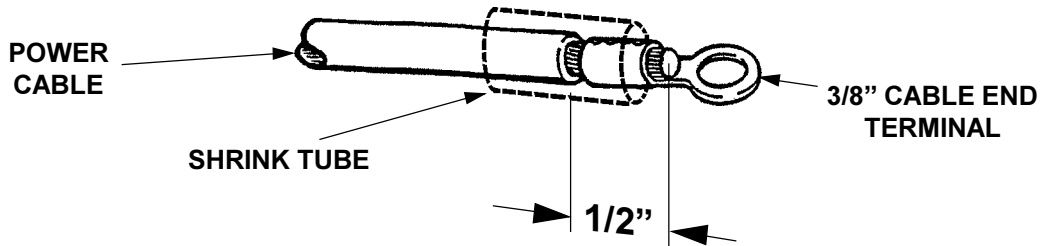

Strip about 1/2" of the insulation from the end and slide one of the pieces of shrink tube far enough down that it's out of your way. Solder the terminal end firmly onto the cable.

Always wear protective eye covering while you are doing soldering operations.

When it's cool, slide the shrink tube over the terminal end and heat with a heat gun til it shrinks tightly over the cable and terminal.

NOTE:

Proper cable connections are extremely important to insure a long and efficient life to all electrical components, therefore, solder type terminals, solder and shrink tubing are provided to insure proper connections. Please do not use the hammer smashing method since the constant bouncing and vibration of the vehicle can eventually cause these types of joints to loosen and deteriorate.

This could also be true of crimping if not done properly or the wrong size tool is used.

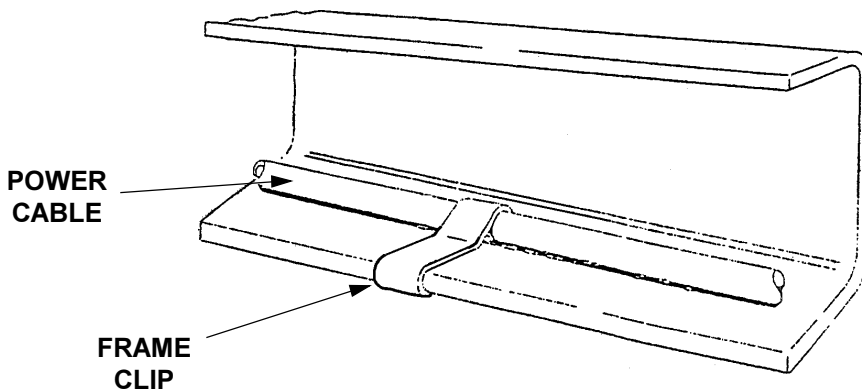

POWER PACK INSTALLATION

TRUCKS ONLY

Route the two hoses (3 if hydraulic closer) and the three conductor cord (two cords if hydraulic closer), that come out of the bottom of the lift gate main frame through the power pak box and connect as shown.

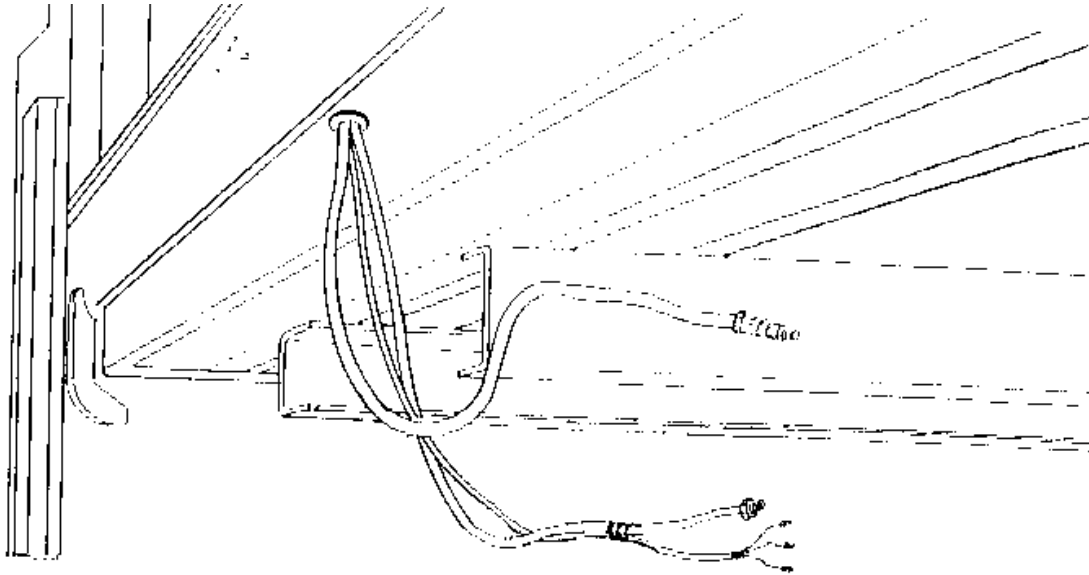

TRAILERS ONLY

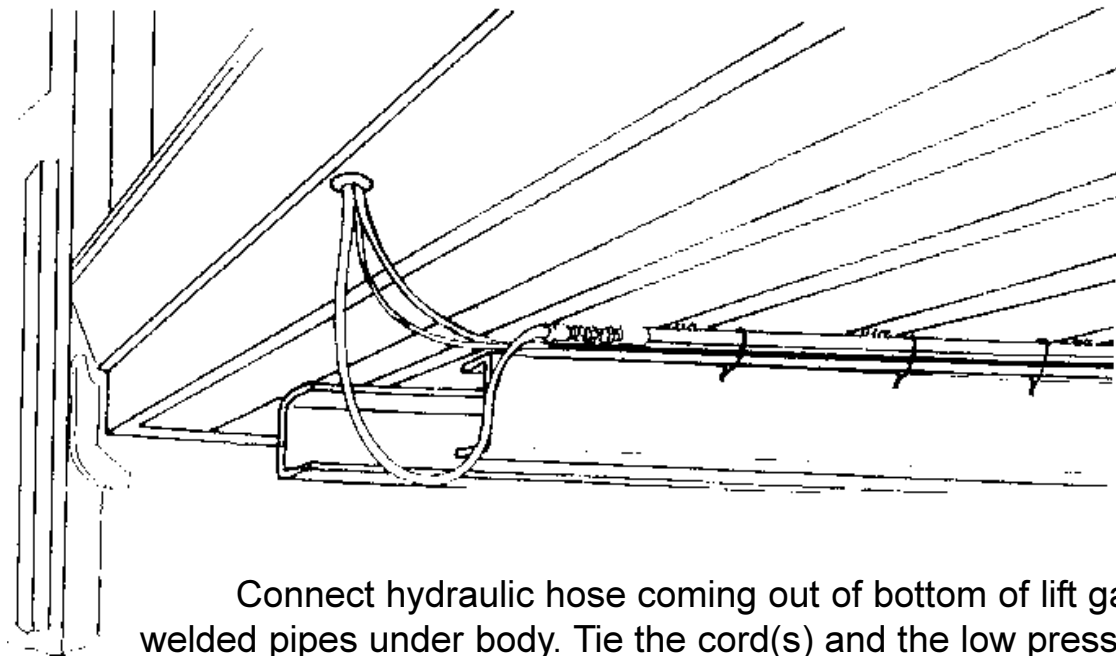

Connect hydraulic hose coming out of bottom of lift gate to welded pipes under body. Tie the cord(s) and the low pressure line to the pipe and route through power unit box.

FUSED POWER CABLE

Short End to Vehicle Battery



Battery Cable Assembly (32' Std.)
(Includes Replacement Fuse Kit)
P/N 264422

200AMP Replacement Fuse Kit (P/N 264687)

WARNING
Do not attach cable to battery until liftgate is completely installed.

Long End to Motor Solenoid

ADDITIONAL AVAILABLE BATTERY CABLE KITS

	PART NUMBER	
40' CABLE ASSEMBLY	264848	Cable Assembly 
10' EXTENSION CABLE ASSEMBLY	264849	Extension Cable Assembly 

MAXON[®]

11921 Slauson Ave. Santa Fe Springs, CA. 90670 (800) 227-4116 FAX (888) 771-7713

PUMP WIRING CAM CLOSER

TOGGLE SWITCH

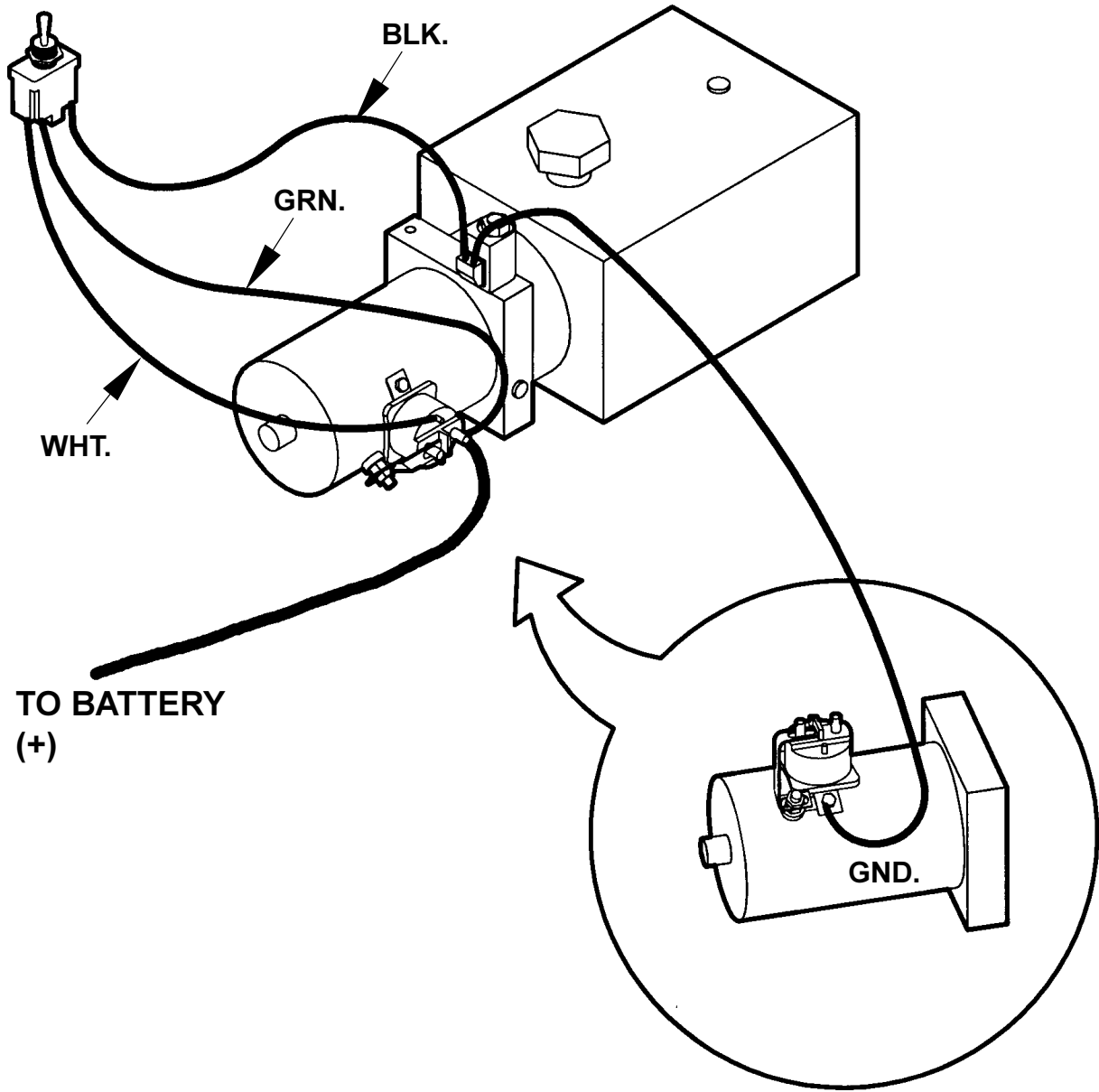

	POWER TO
UP	WHT.
DOWN	BLK.

PUMP WIRING HYDRAULIC CLOSER

MAXON® 11921 Slauson Ave. Santa Fe Springs, CA. 90670 (800) 227-4116 FAX (888) 771-7713

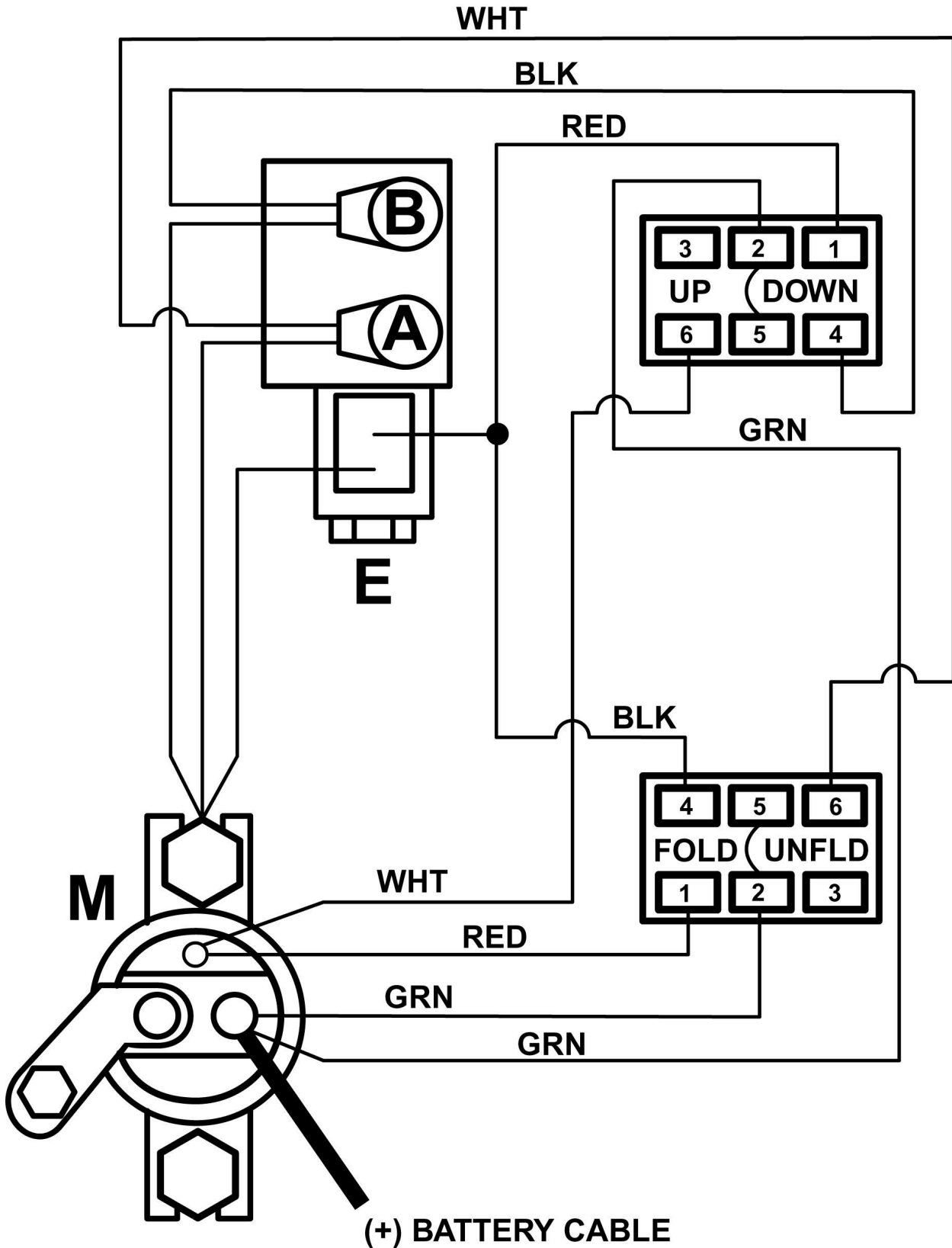

FINAL ADJUSTMENTS

Fill the system with fluid by activating the raise control switch until the runners hit the stops.

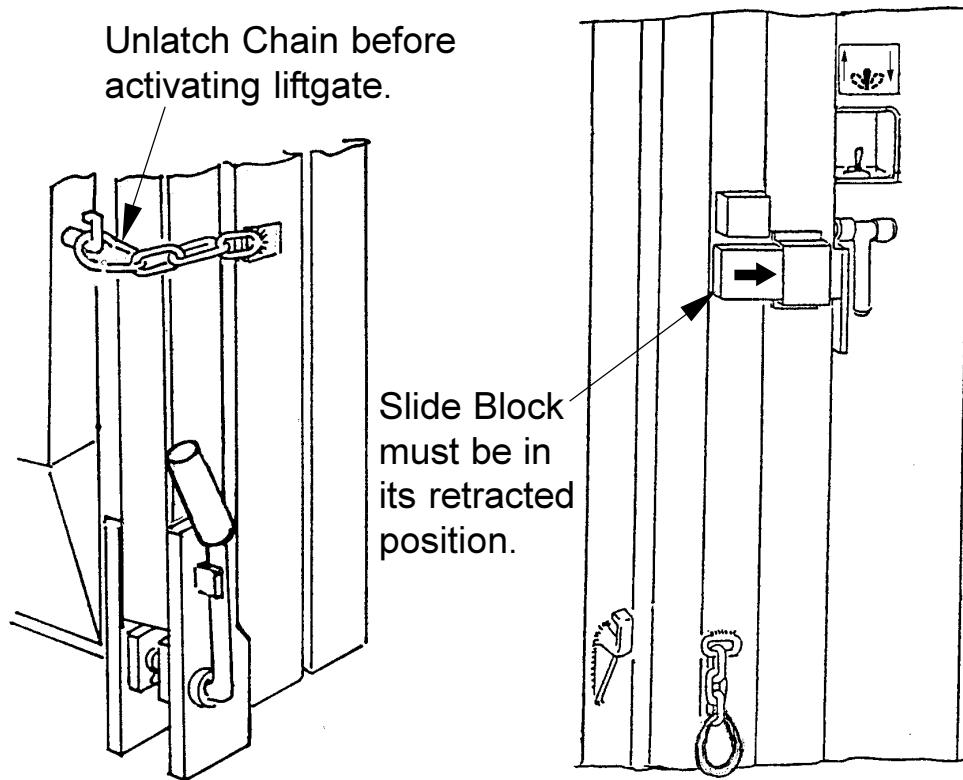

Remove platform holding chain and activate switch to let unit down until platform rests on ground.

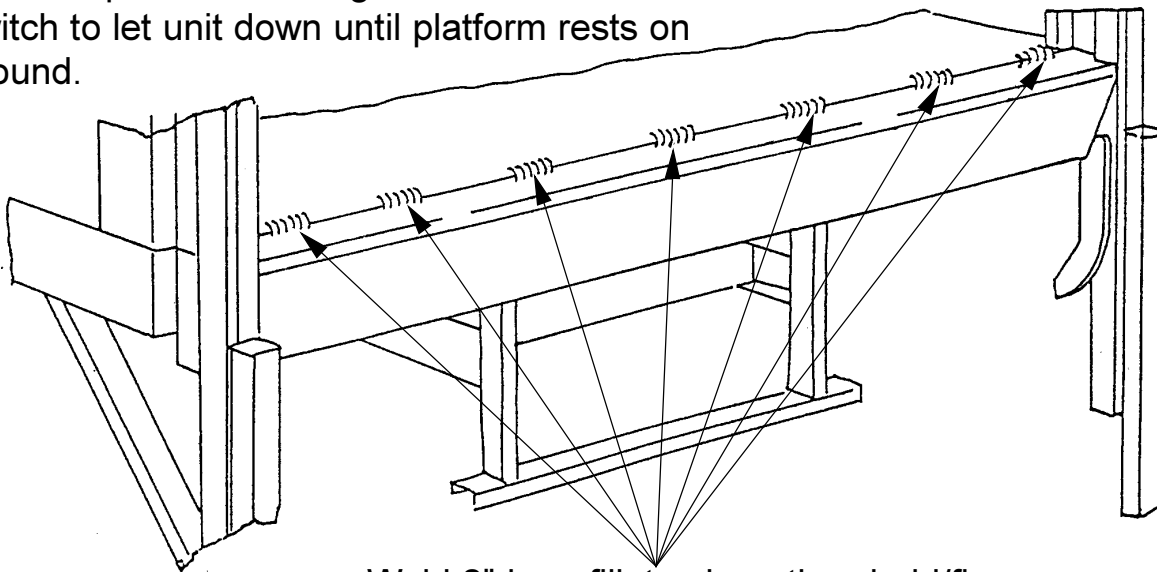

Weld 2" long fillets along threshold/floor about every 8 to 10 inches. No welding is necessary on the bottom.

FINAL ADJUSTMENTS

Adjust Flow Control valve on power pak so that platform opens from a vertical position just slow enough so as not to create a banging condition.

To ensure that the platform brakes are working properly, perform the following simple test:

1. Open Platform and let unit down so that the bottom of the Runner on one side rests on a floor jack.
2. Raise the jack about 3" or so and let the jack down.
3. The Runner should stay in the position that it was jacked up to. If it falls down to its original position resting on the jack, then the brake is not working and must be checked.
4. To release engaged brake, raise unit.

Perform test on opposite side as well.

If platform raises uneven from side to side, adjust per instructions in maintenance manual. Install lights and add decals.

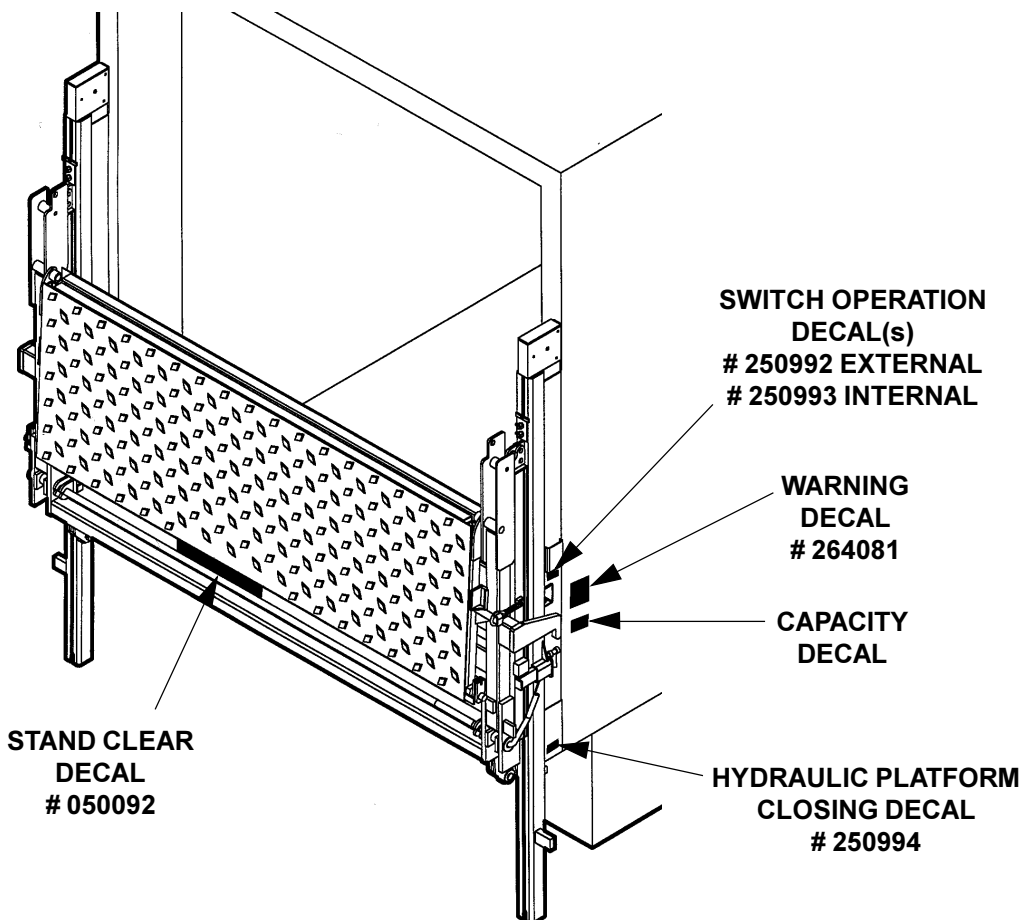

OPTIONAL INSTALLATIONS

RCT LIGHT INSTALLATION

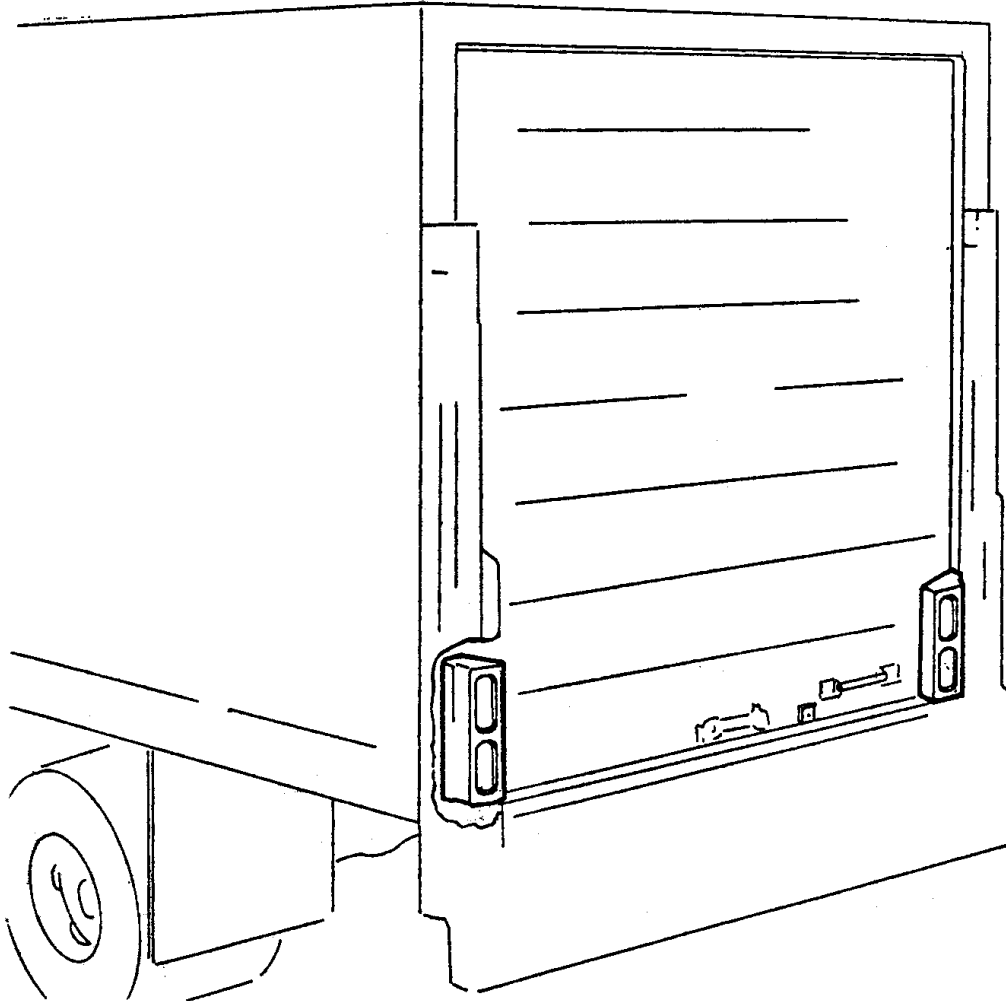

ALL RCT UNITS INCLUDE BACK LIGHTS

MAXON[®]

11921 Slauson Ave. Santa Fe Springs, CA. 90670 (800) 227-4116 FAX (888) 771-7713

RCT LIGHT INSTALLATION

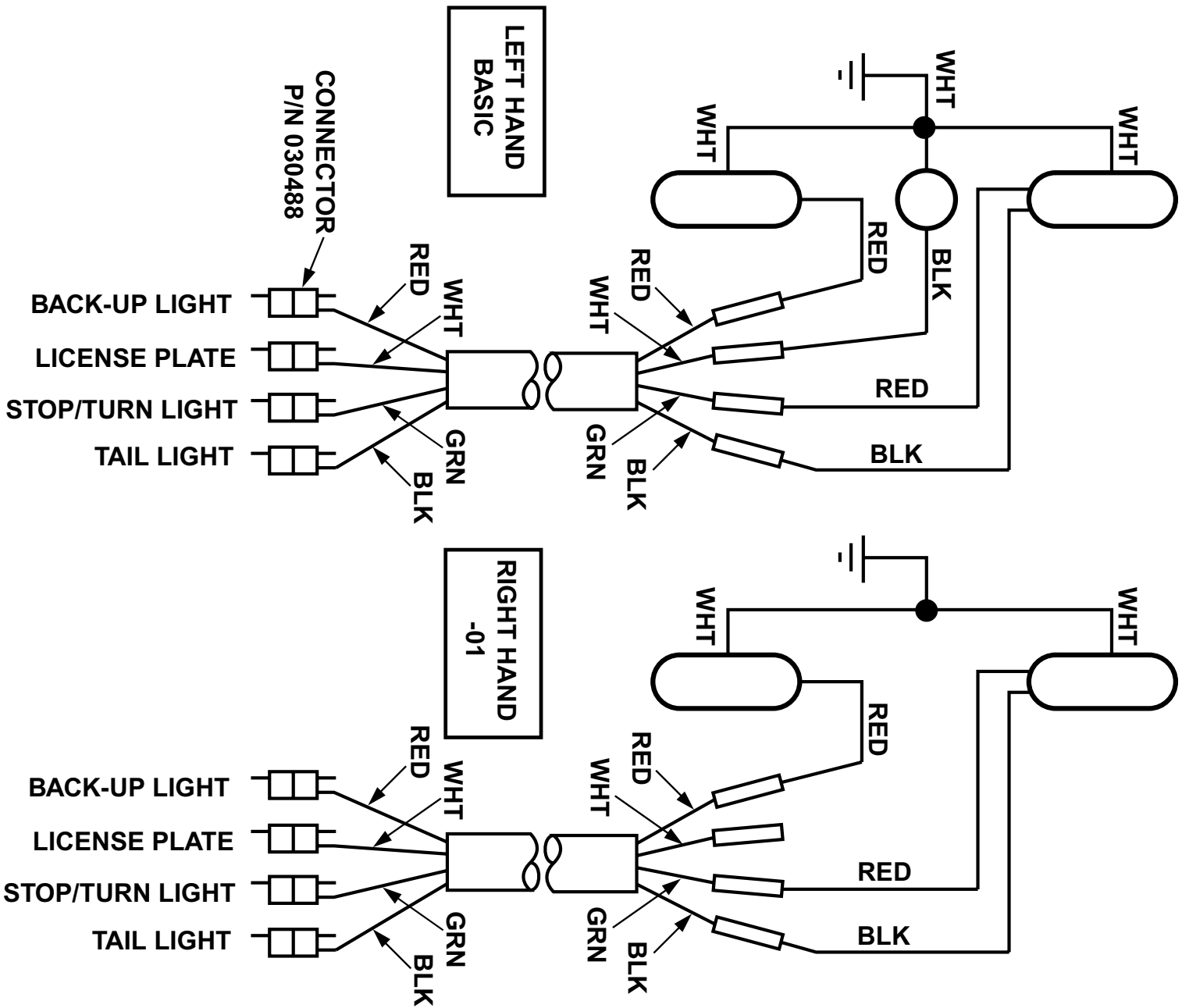

HAND PUMP OPTION FOR CAM CLOSER

The procedure for lifting the platform using the hand pump is as follows:

1. Check if the relief valve is closed by using the handle to turn it clockwise until complete stop.
2. Close the flow control valve by turning the knob clockwise until it is fully closed.
3. Locate the handle in the hand pump and operate with an up and down motion.

To lower the platform, open the hand pump relief valve slowly to be able to control the down speed with this valve.

NOTE:

- When going back to normal operation,
- a. Be sure to have the hand pump closed.
 - b. Open and adjust the flow control valve.

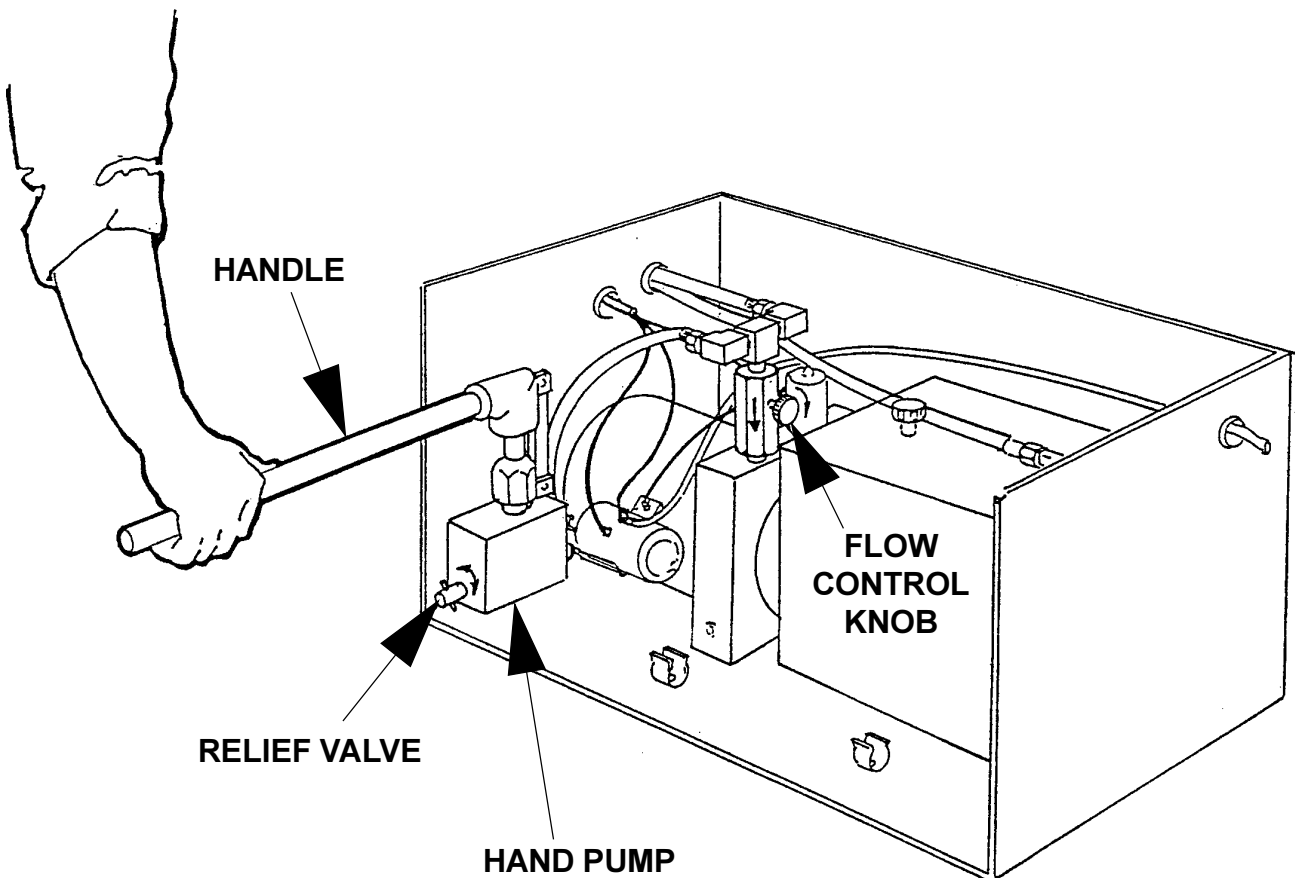

BATTERY PAK INSTALLATION (For Trailers)

Mount the battery pak on either side of the trailer body, as close to the power source as possible. Using a floor jack or other lifting device, raise the box so that its top touches the underside of the cross members and tack weld to the crossmembers (unless the cross members are aluminum).

Place the four plates (included with this kit) against the cross members and slide down against the battery pak. Weld to both structures. (NOTE: Holes are provided in the mounting plates to allow bolting to aluminum cross members).

Make sure the box is not in a position to interfere with the wheels of the trailer with sliding axle.

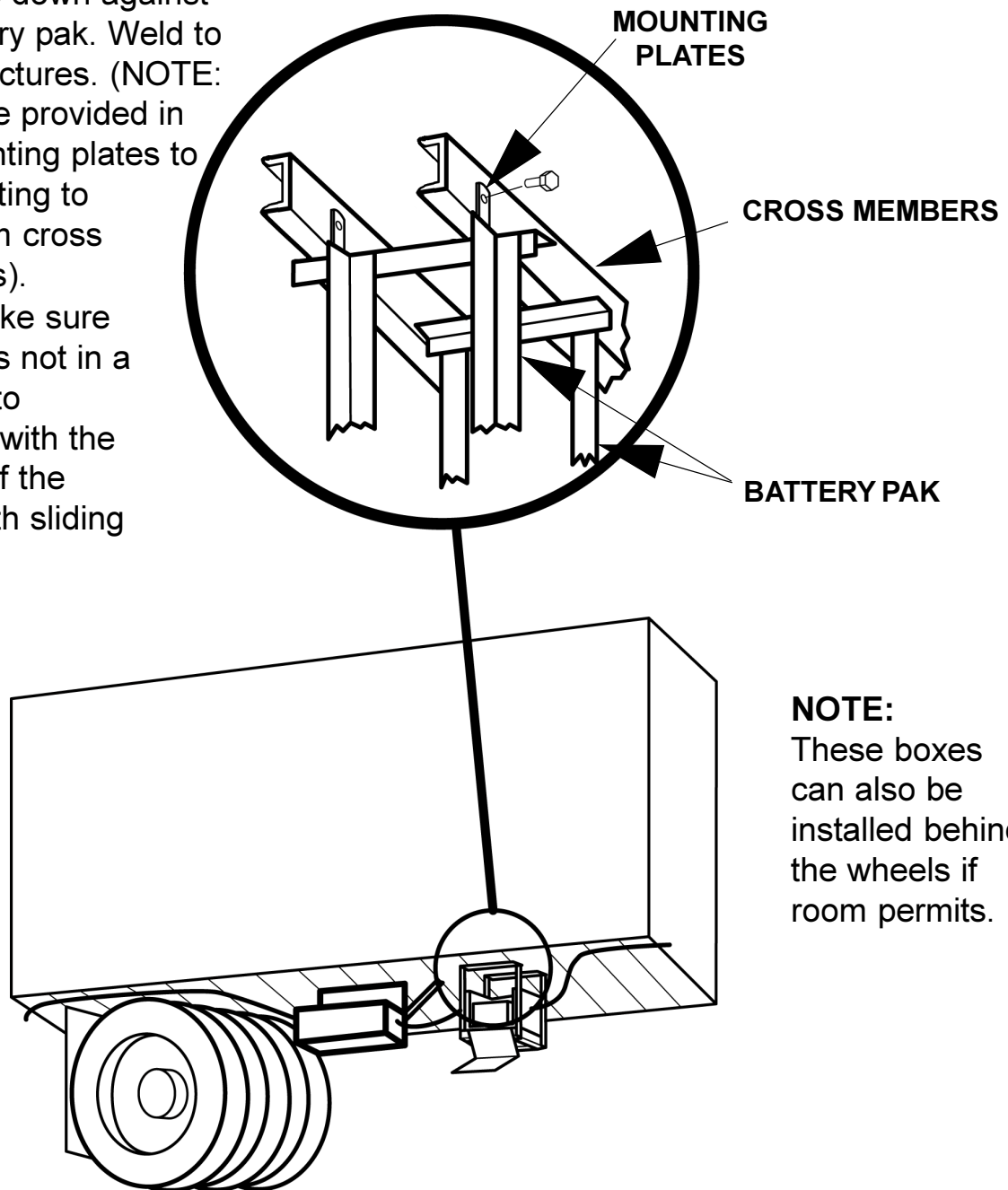

For easier service, mount boxes so that the front of each box is recessed one foot from the side wall of the vehicle body.

TRACTOR TO TRAILER CONNECTION (TRACTOR CHASSIS SHOWN)

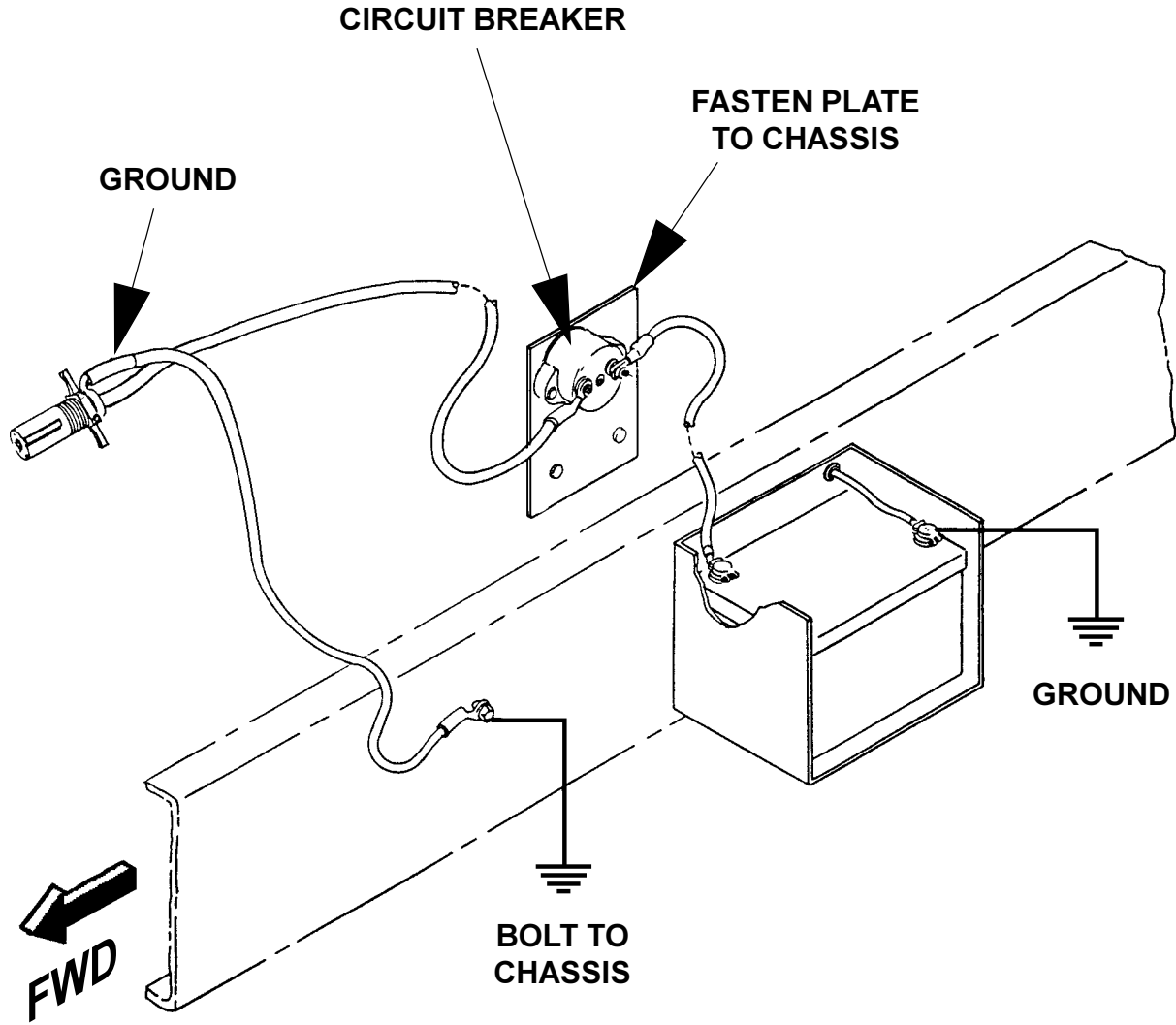

MAXON[®]

11921 Slauson Ave. Santa Fe Springs, CA. 90670 (800) 227-4116 FAX (888) 771-7713

INSTALLING POWER CABLE CONNECTOR (For Trailers)

Select an area on the front wall of the trailer as close to the center as possible and install the socket portion of the connector plug. Use the screws provided.

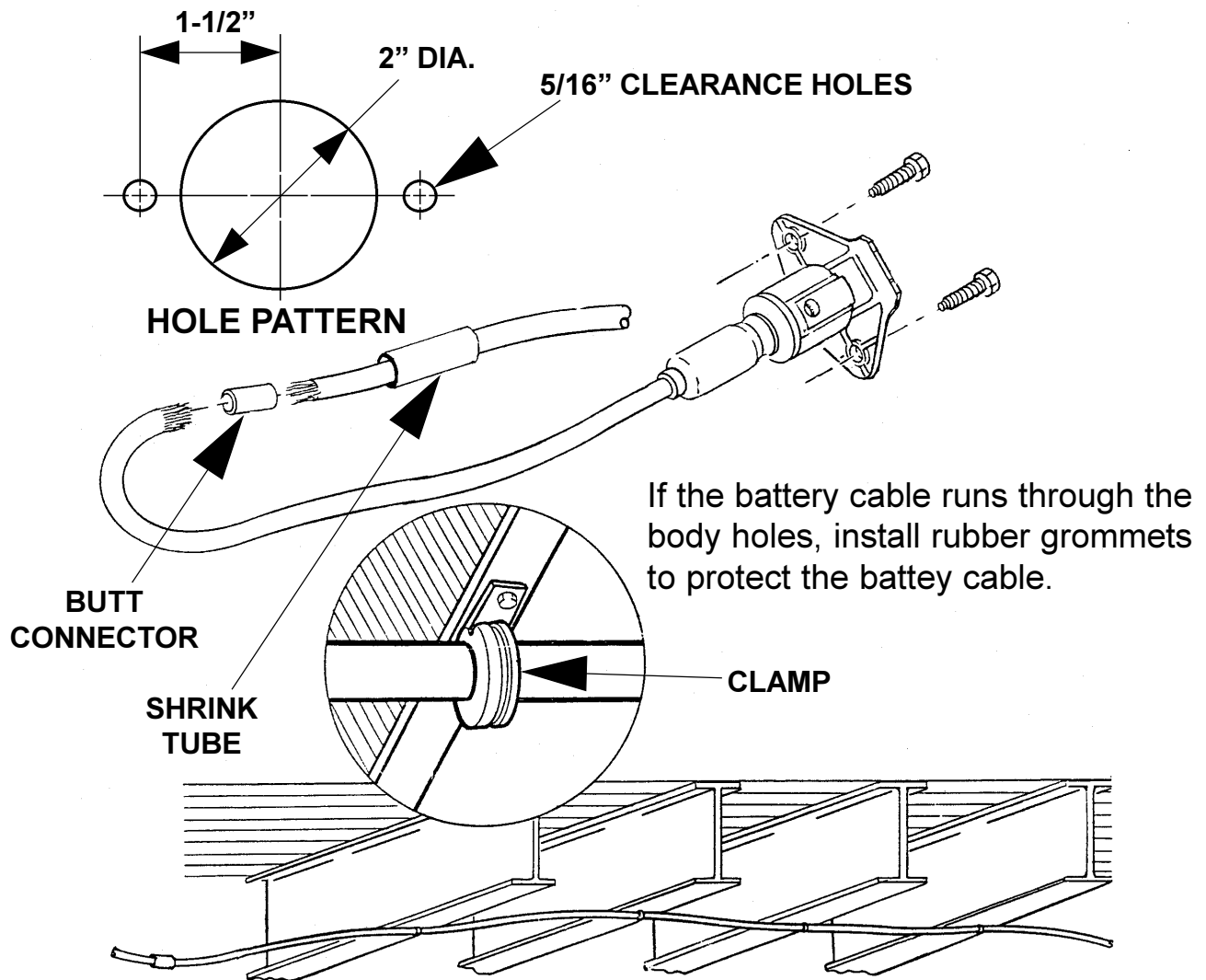

Using butt connector and solder (supplied), splice this cable to the 32' cable and run along the underside of the floor cross members to the battery pak. Use clamps to secure the cable to the cross members. Heat shrink tube over splice to insulate.

Care should be taken to insure that the cable does not come in contact with sharp edges of bare metal that could cause the breaking or wearing away of the insulation.

BATTERY CABLE MOUNTING, 6 VOLT SYSTEM

MAXON

11921 Slauson Ave. Santa Fe Springs, CA. 90670 (800) 227-4116 FAX (888) 771-7713

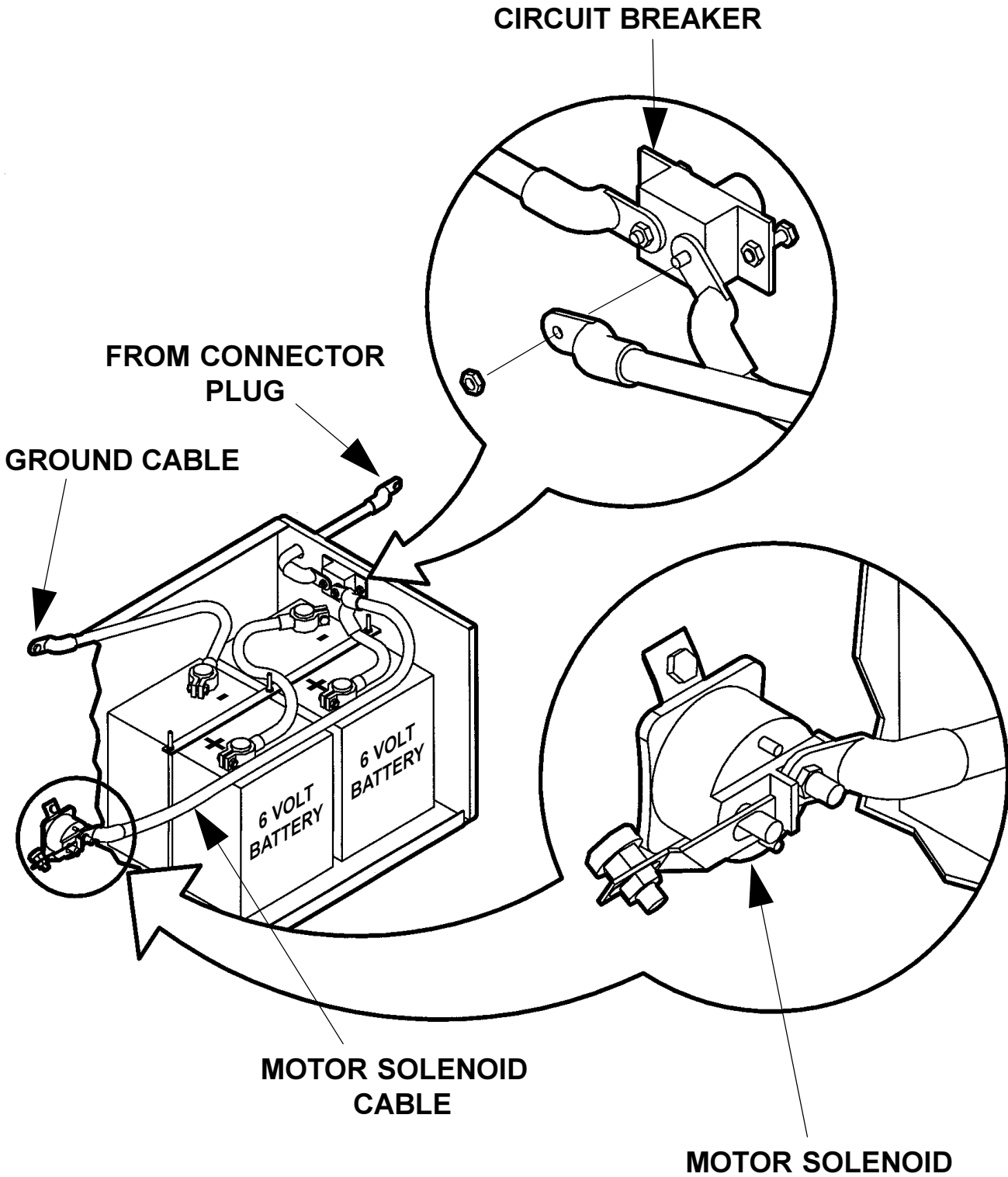

BATTERY CABLE MOUNTING, 12 VOLT SYSTEM

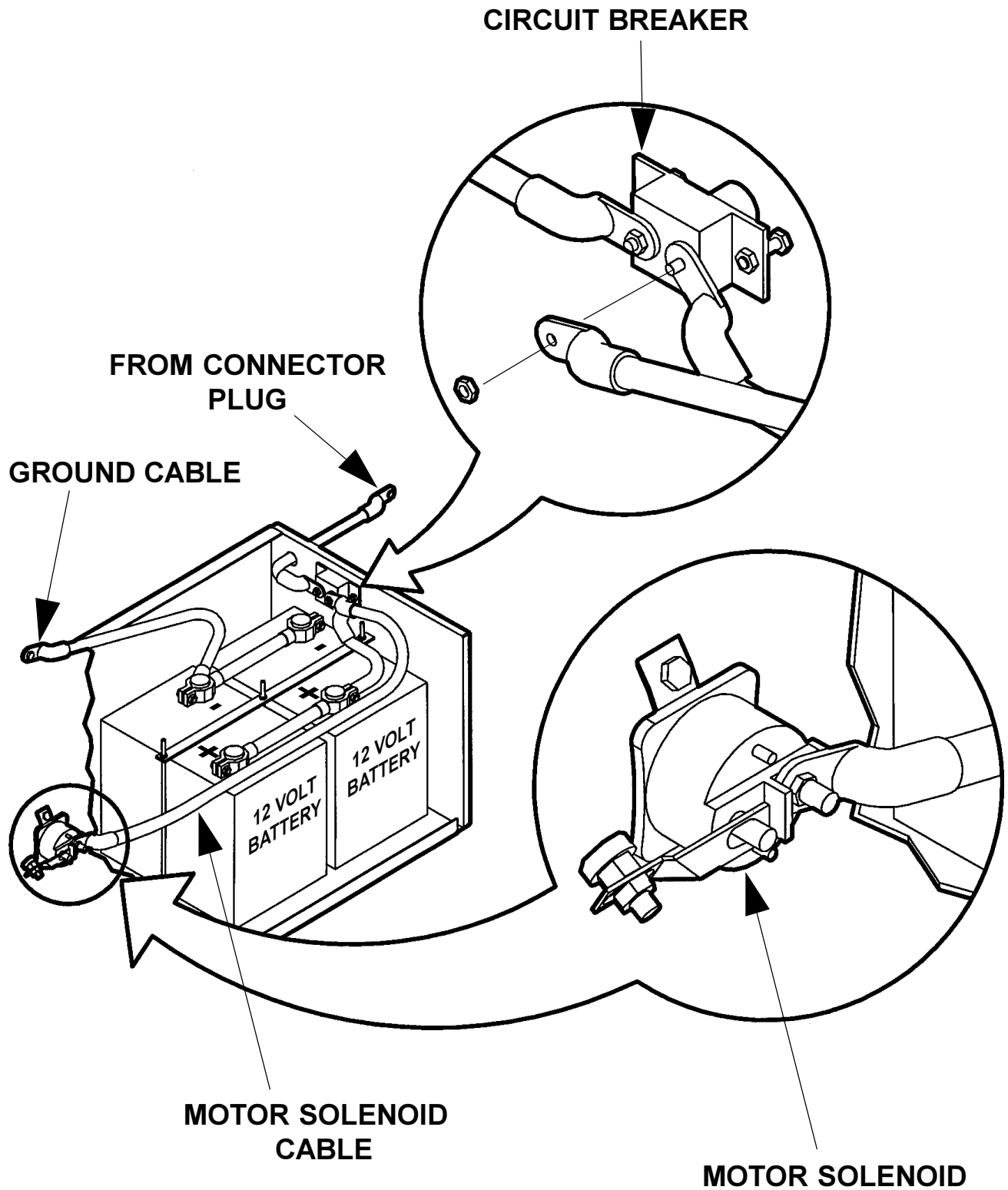

FIXED RAMP INSTALLATION, 6"

Lower the platform to level ground. Line up top edge of ramp with the front edge of the platform.

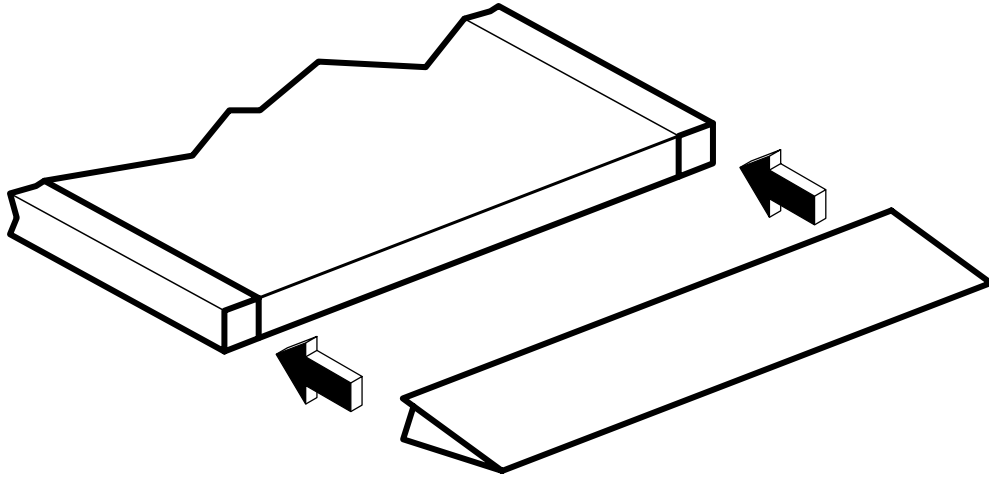

Weld 1/8" beads two inches long about every 6 or 8 inches along the entire length of the platform. Repeat procedure for the underside of the platform.

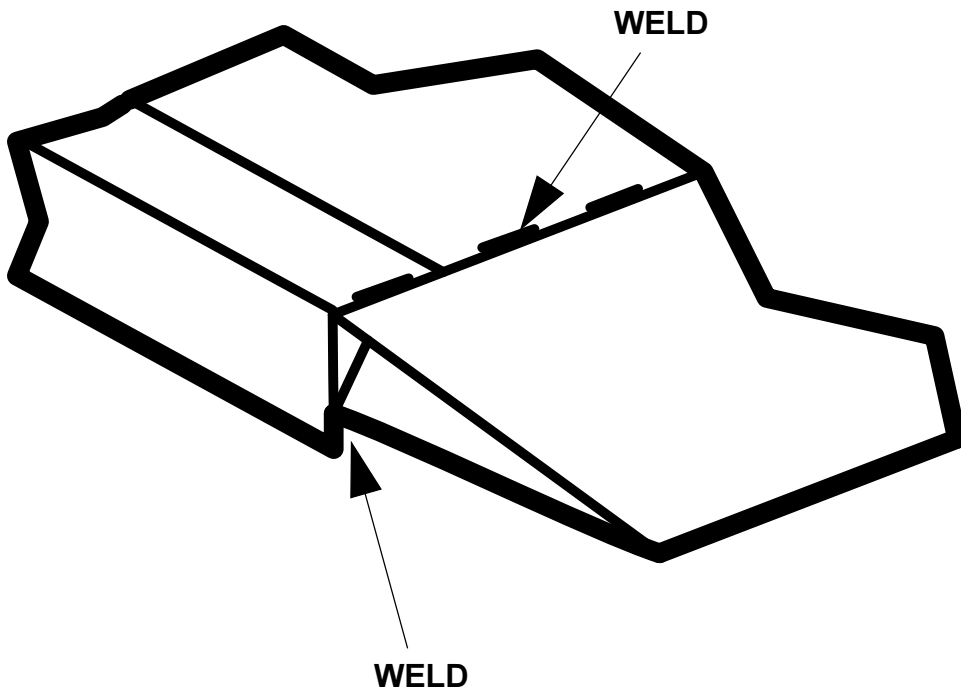

MAXON[®]

11921 Slauson Ave. Santa Fe Springs, CA. 90670 (800) 227-4116 FAX (888) 771-7713

FIXED RAMP INSTALLATION, 12"

Lower the platform to level ground. Line up top edge of ramp with the front edge of the platform.

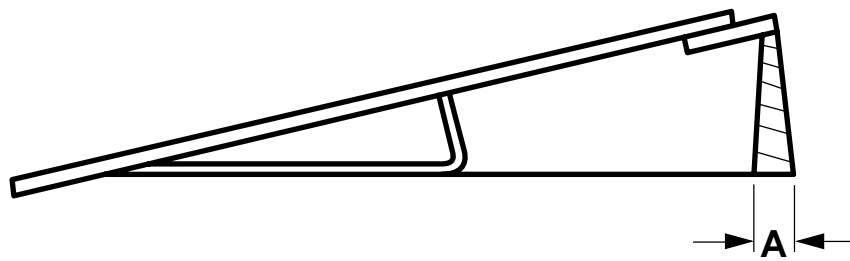
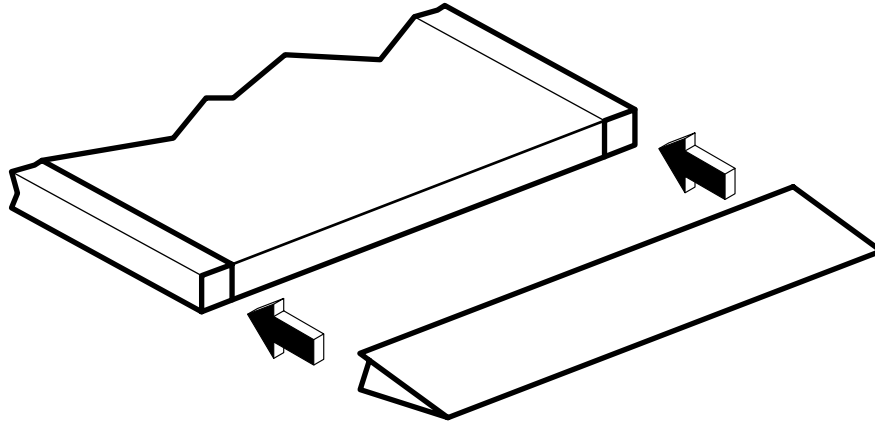

Cut rear edges of ramp as shown:
Single piece platform "A" = 3/8"
Folding platforms "A" = 1/2"

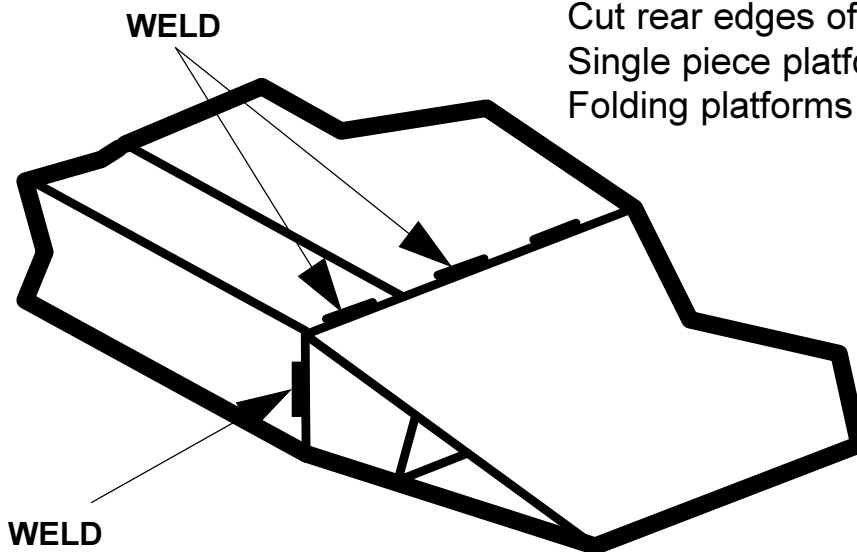

Weld 1/8" beads two inches long about every 6 or 8 inches along the entire length of the platform. Repeat procedure for the underside of the platform. Weld gussets full length.

CART STOP & DUAL CART STOP RAMP INSTALLATION

1. With the platform on the ground, center the Cart Stop Ramp against the butt end of the platform. Rest the Ramp Blocks on top of the platform and let the Ramp Tip touch the ground. Weld both sides into place.

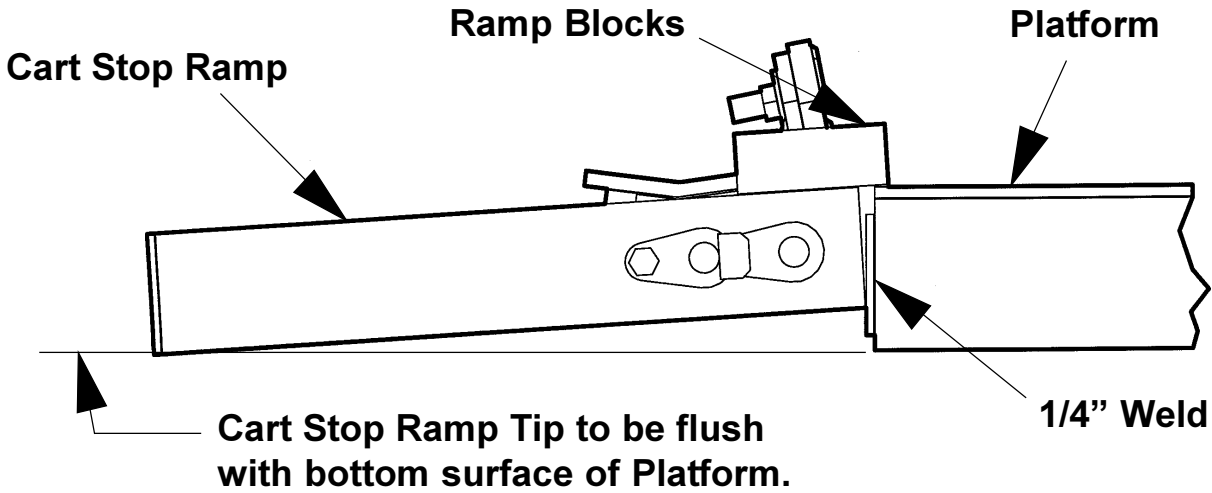

2. Pop open the Cart Stop Section of the ramp for ease of welding. Weld the top & bottom of the Ramp to the Platform with 2" long welds on approximately 12" centers. Grind all welds smooth and touch up with paint.

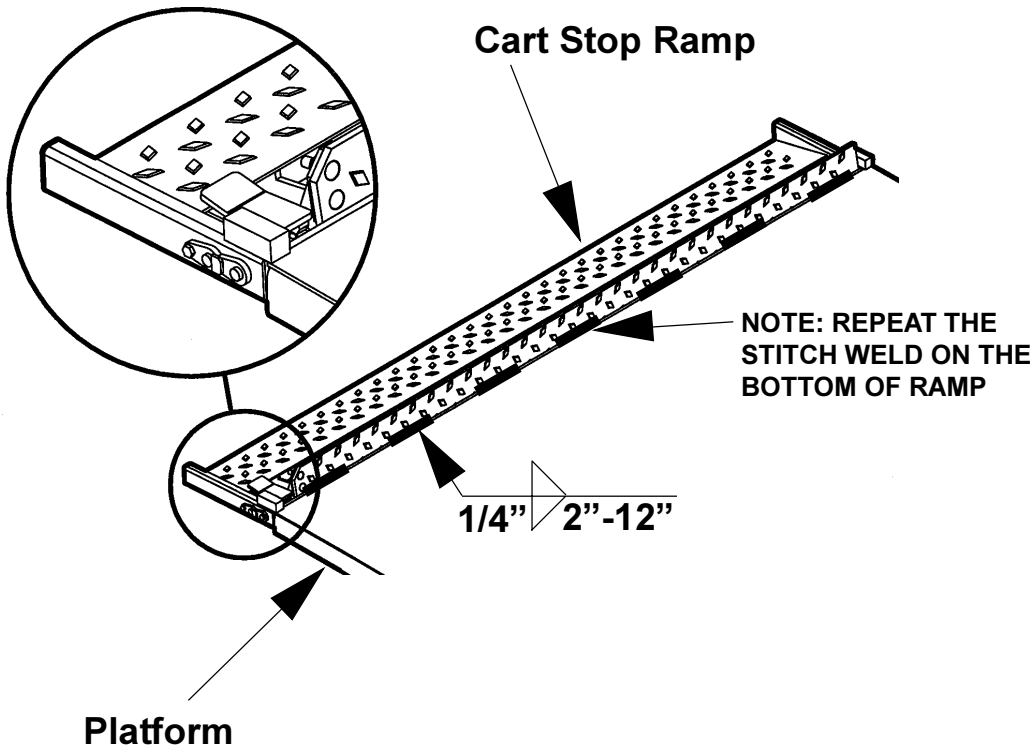

MAXON

11921 Slauson Ave. Santa Fe Springs, CA. 90670 (800) 227-4116 FAX (888) 771-7713

HINGED RAMP INSTALLATION (STEEL)

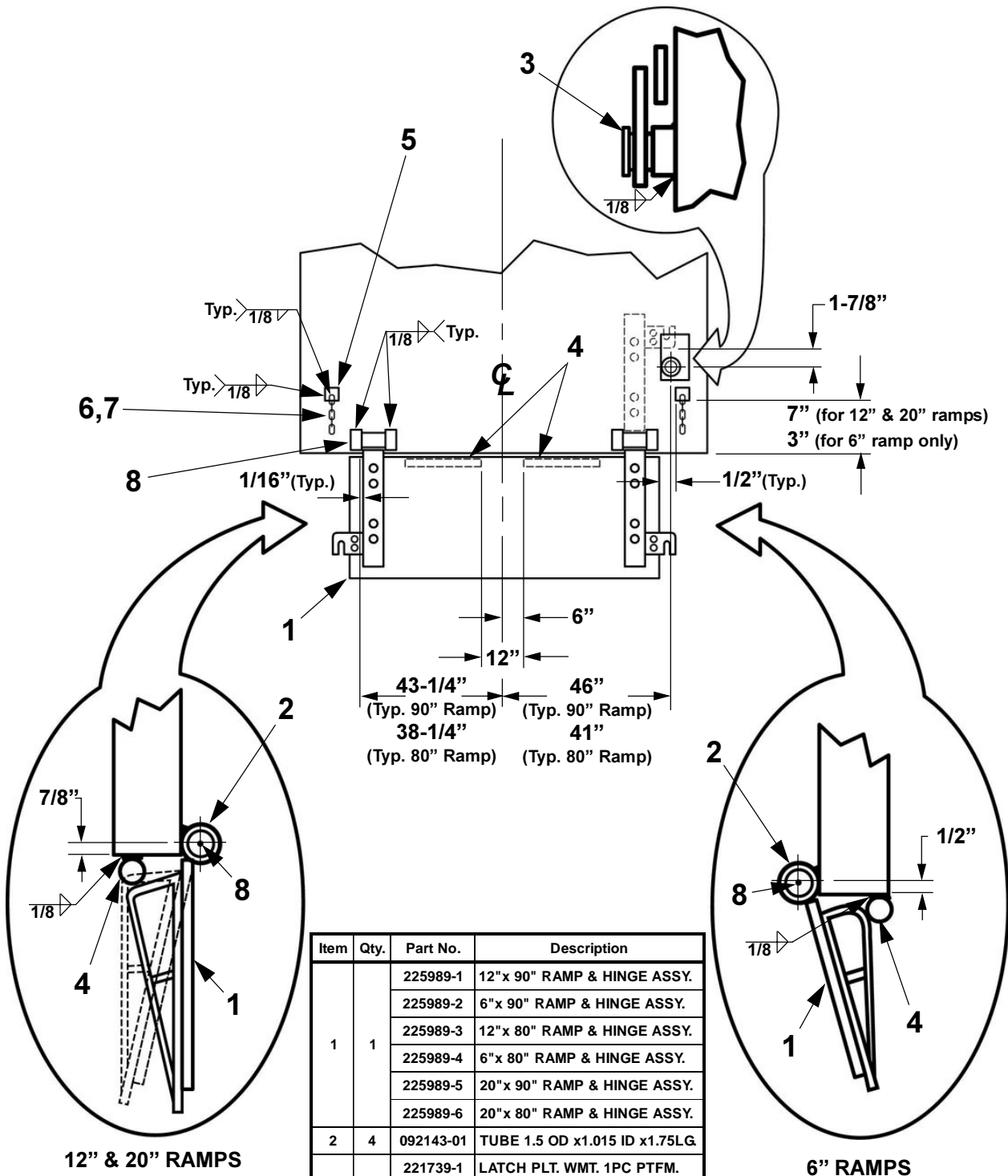

Item	Qty.	Part No.	Description
1	1	225989-1	12"x 90" RAMP & HINGE ASSY.
		225989-2	6"x 90" RAMP & HINGE ASSY.
		225989-3	12"x 80" RAMP & HINGE ASSY.
		225989-4	6"x 80" RAMP & HINGE ASSY.
		225989-5	20"x 90" RAMP & HINGE ASSY.
		225989-6	20"x 80" RAMP & HINGE ASSY.
2	4	092143-01	TUBE 1.5 OD x1.015 ID x1.75LG.
3	1	221739-1	LATCH PLT. WMT. 1PC PTFM.
		221739-2	LATCH PLT. WMT. 2PC PTFM.
4	2	225998	BAR RD. 3/4" DIA. x 8" LG.
5	2	201020	FLAT, 3/8 x 1 x 1-1/2" LG
6	2	202698-41	CHAIN 18" LG. (12" & 20" RAMP ONLY)
7	2	202698-43	CHAIN 11" LG. (6" RAMP ONLY)
8	2	224342	LUBE FITTING

HINGED RAMP INSTALLATION (ALUMINUM)

MAXON[®] 11921 Slauson Ave. Santa Fe Springs, CA. 90670 (800) 227-4116 FAX (888) 771-7713

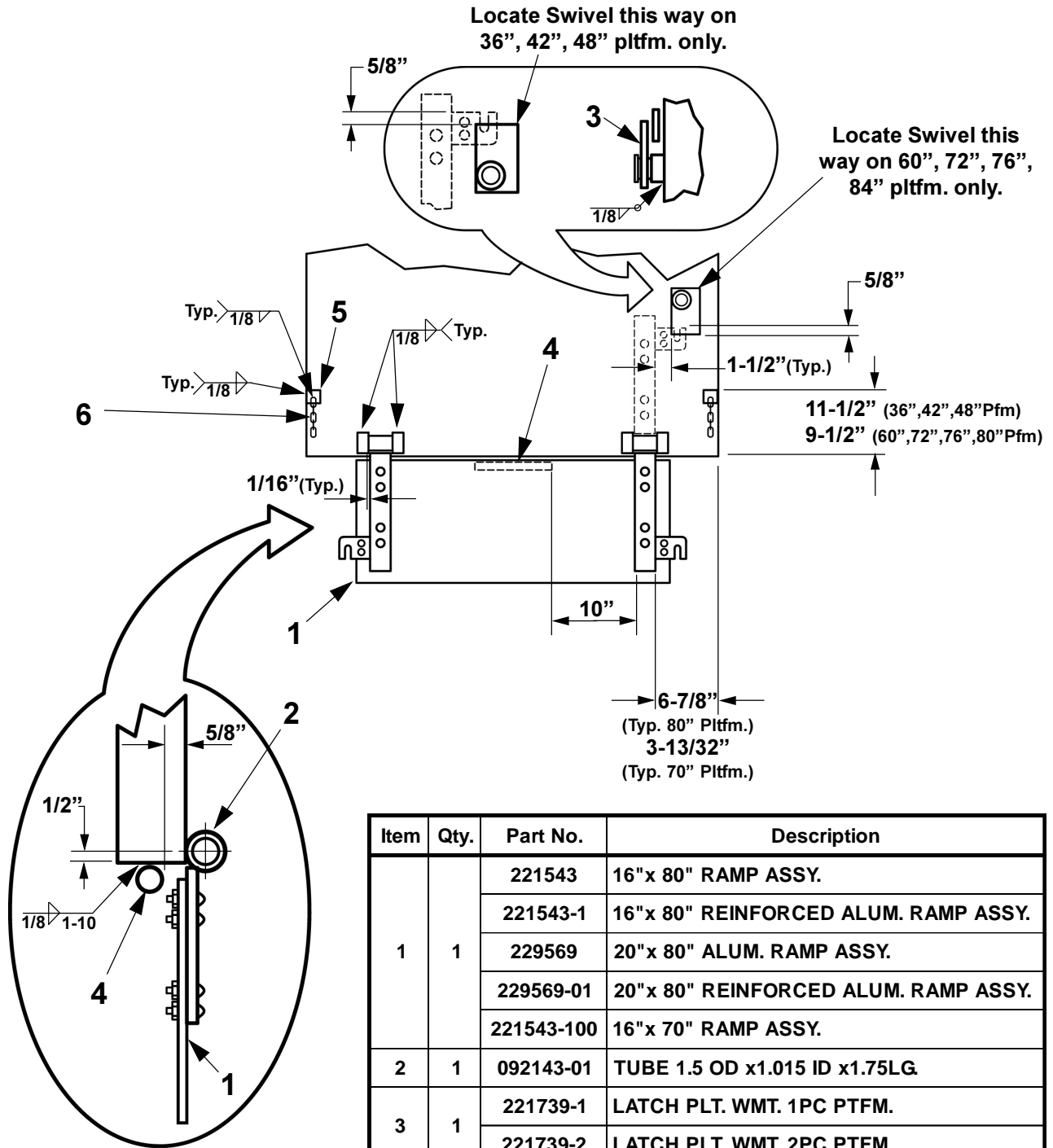

Item	Qty.	Part No.	Description
1	1	221543	16"x 80" RAMP ASSY.
		221543-1	16"x 80" REINFORCED ALUM. RAMP ASSY.
		229569	20"x 80" ALUM. RAMP ASSY.
		229569-01	20"x 80" REINFORCED ALUM. RAMP ASSY.
		221543-100	16"x 70" RAMP ASSY.
2	1	092143-01	TUBE 1.5 OD x1.015 ID x1.75LG.
3	1	221739-1	LATCH PLT. WMT. 1PC PTFM.
		221739-2	LATCH PLT. WMT. 2PC PTFM.
4	1	225985	PIPE 3/4" SCH. 80 x 60" LG.
5	2	201020	FLAT, 3/8 x 1 x 1-1/2" LG
6	2	202698-41	CHAIN 18" LG.