

M-90-1
REV. H
OCTOBER 2012

MAXON[®]

INSTALLATION

MANUAL

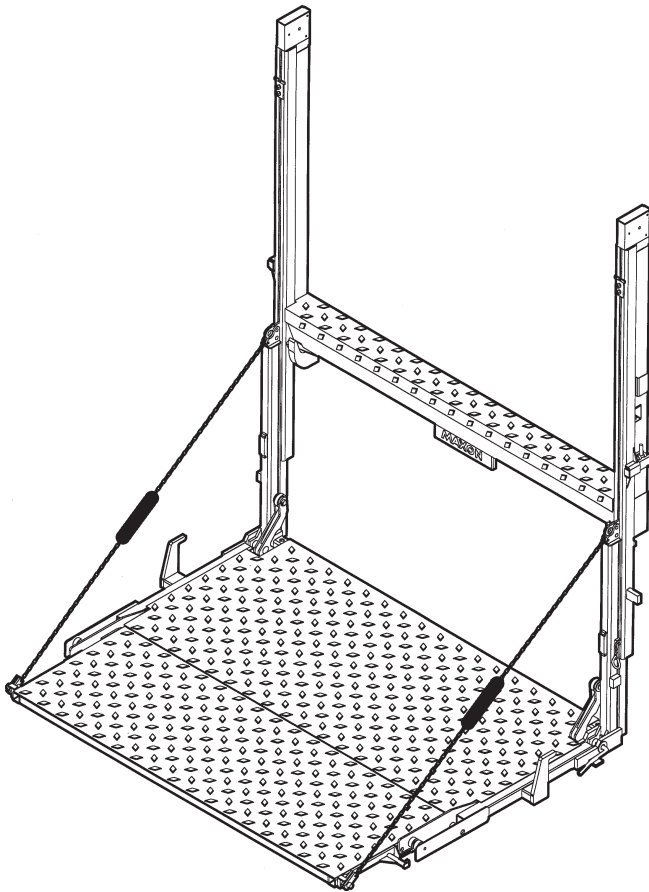

RC-2B

RC-3B

RC-4B

RC-5B

RC-6B

RC-6K

MAXON[®]

11921 Slauson Avenue.
Santa Fe Springs, CA. 90670
(800) 227-4116

TABLE OF CONTENTS

WARNINGS	3
SAFETY INSTRUCTIONS	3
INTRODUCTION	4
UNIT AS SHIPPED.....	5
INSTALLATION OF UNIT	6
WELDING TO FLATBED	11
HYDRAULIC PIPE INSTALLATION	12
ATTACH OPTIONAL BATTERY BOX & FRAME TO VEHICLE (IF EQUIPPED)	13
POWER PACK INSTALLATION	19
FUSED POWER CABLE	22
PUMP WIRING CAM CLOSER	23
PUMP WIRING HYDRAULIC CLOSER	24
ADD HYDRAULIC FLUID.....	25
FINAL ADJUSTMENTS	27
ATTACH DECALS	29
OPTIONS	31
RCT LIGHT INSTALLATION.....	31
HAND PUMP OPTION FOR CAM CLOSER.....	33
RECOMMENDED LIFTGATE POWER CONFIGURATION	34
FIXED RAMP INSTALLATION, 6"	36
FIXED RAMP INSTALLATION, 12"	37
CART STOP & DUAL CART STOP RAMP INSTALLATION.....	38
HINGED RAMP INSTALLATION (STEEL)	39
HINGED RAMP INSTALLATION (ALUMINUM).....	40

MAXON[®] 11921 Slauson Ave. Santa Fe Springs, CA. 90670 (800) 227-4116 FAX (888) 771-7713

Comply with the following **WARNINGS** and **SAFETY INSTRUCTIONS** while installing Liftgates. See **Operation Manual** for operating safety requirements.

WARNING

- Do not stand, or allow obstructions, under the platform when lowering the Liftgate. **Be sure your feet are clear of the Liftgate.**
- **Keep fingers, hands, arms, legs, and feet clear of moving Liftgate parts (and platform edges) when operating the Liftgate.**
- **Correctly stow platform when not in use. Extended platforms could create a hazard for people and vehicles passing by.**
- **Make sure vehicle battery power is disconnected** while installing Liftgate. Connect vehicle battery power to the Liftgate only when installation is complete or as required in the installation instructions.
- If it is necessary to stand on the platform while operating the Liftgate, keep your feet and any objects clear of the inboard edge of the platform. Your feet or objects on the platform can become trapped between the platform and the Liftgate extension plate.
- Never perform unauthorized modifications on the Liftgate. Modifications may result in early failure of the Liftgate and may create hazards for Liftgate operators and maintainers.
- Recommended practices for welding on steel parts are contained in the current **AWS (American Welding Society) D1.1 Structural Welding Code - Steel**. Damage to Liftgate and/or vehicle, and personal injury can result from welds that are done incorrectly.

SAFETY INSTRUCTIONS

- Read and understand the instructions in this **Installation Manual** before installing Liftgate.
- Before operating the Liftgate, read and understand the operating instructions in **Operation Manual**.
- Comply with all **WARNING** and instruction decals attached to the Liftgate.
- Keep decals clean and legible. If decals are illegible or missing, replace them. Free replacement decals are available from **Maxon Customer Service**.
- Consider the safety and location of bystanders and location of nearby objects when operating the Liftgate. Stand to one side of the platform while operating the Liftgate
- Do not allow untrained persons to operate the Liftgate.
- Wear appropriate safety equipment such as protective eyeglasses, faceshield and clothing while performing maintenance on the Liftgate and handling the battery. Debris from drilling and contact with battery acid may injure unprotected eyes and skin.
- Be careful working by an automotive type battery. Make sure the work area is well ventilated and there are no flames or sparks near the battery. Never lay objects on the battery that can short the terminals together. If battery acid gets in your eyes, immediately seek first aid. If acid gets on your skin, immediately wash it off with soap and water.
- If an emergency situation arises (vehicle or Liftgate) while operating the Liftgate, release the control switch to stop the Liftgate.
- A correctly installed Liftgate operates smoothly and reasonably quiet. The only noticeable noise during operation comes from the power unit while the platform is raised and lowered. Listen for scraping, grating and binding noises and correct the problem before continuing to operate Liftgate.

INTRODUCTION

This publication contains the information required to install the following models and their options; **RC, RCW, RCT, RC-CL**, and **RCHL** from 2000 to 6000 pound capacities. If there is any doubt in your mind regarding the suitability of these lifts being installed on its intended vehicle, or any portion of these instructions that you do not understand, please contact the Maxon Customer Service Department for consultation.

Unauthorized modification to this equipment may cause premature failure or create hazards in its use that are not foreseen at the time of the installation. These kinds of changes should be discussed with our Engineering Department before being undertaken.

Bed height requirements to ground are 38" laden to 56" unladen.

These lifts cannot be installed on bodies with swing type doors.

These lifts have been designed to fit bodies that are 96" wide, (102" wide, in the case of the RCW Models). If this body has dimensions that are much different than these, special brackets will have to be fabricated for attachment. The corner posts of the body must also be made of steel so that the lift columns can be welded to it. If they are aluminum, then steel plates will have to be fabricated to bolt to these corner posts for welding to the lift assembly. Both of the above conditions are rare and therefore have not been provided for in this manual. Contact the Customer Service Department if either of the above conditions exist.

UNIT AS SHIPPED

Do not remove stands at bottom of column until instructed to do so. Steel box containing pump assembly, also contains a packing list, instruction manuals, decals, and all necessary hardware to complete installation.

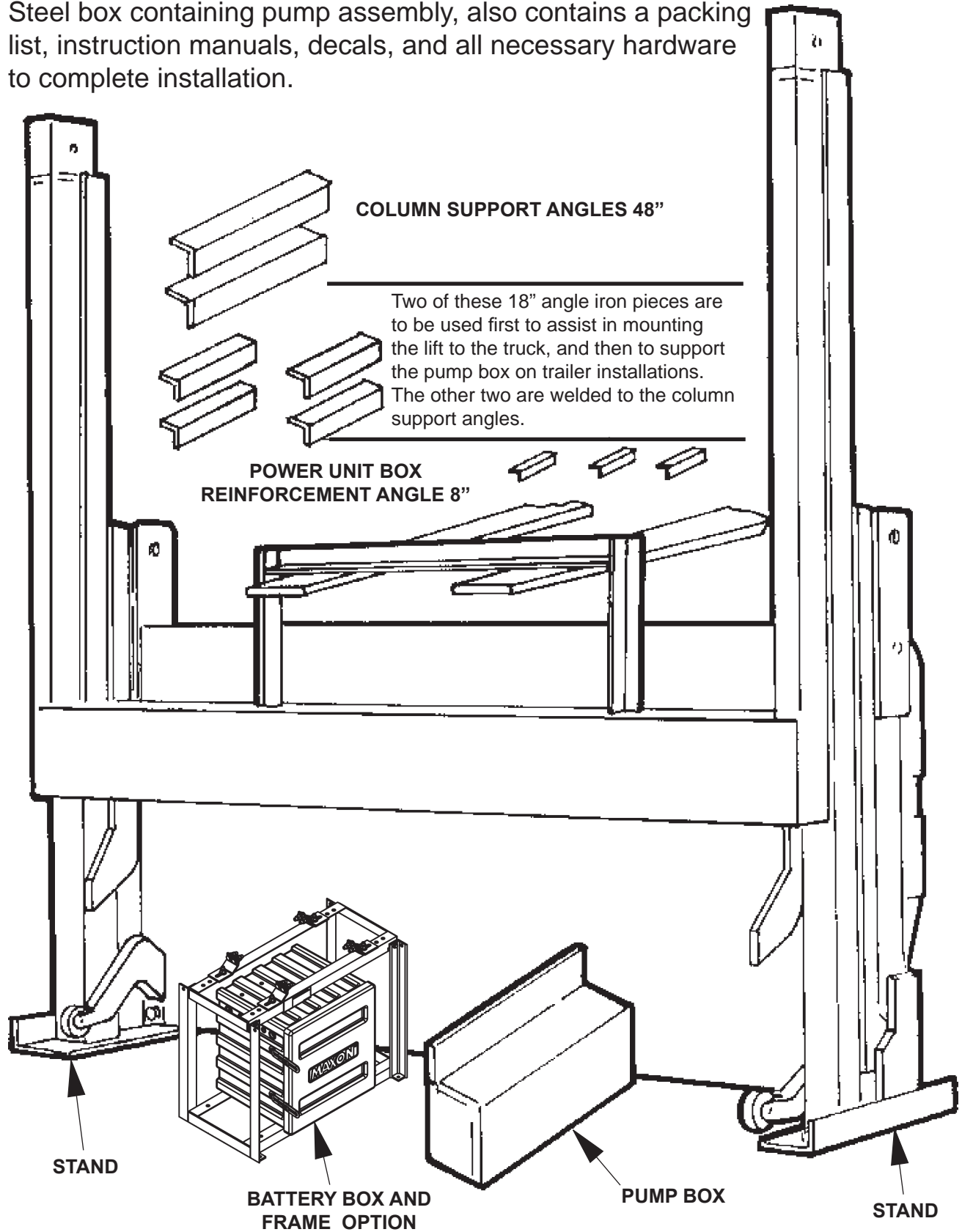

MAXON® 11921 Slauson Ave. Santa Fe Springs, CA. 90670 (800) 227-4116 FAX (888) 771-7713

INSTALLATION OF UNIT

There are two pieces of angle iron supports (2-1/2 x 2-1/2 x 18") that have been provided to assist in lining the unit up to the body. Tack weld them to the top of the lift's main section, just strong enough to support it on the truck floor till the lift is secured and ready to weld. Put a chalk mark on the center of the unit (on the thread plate surface) for aligning with the center of the truck body.

Remove support angles after lift is mounted and use them for pump box mount reinforcement.

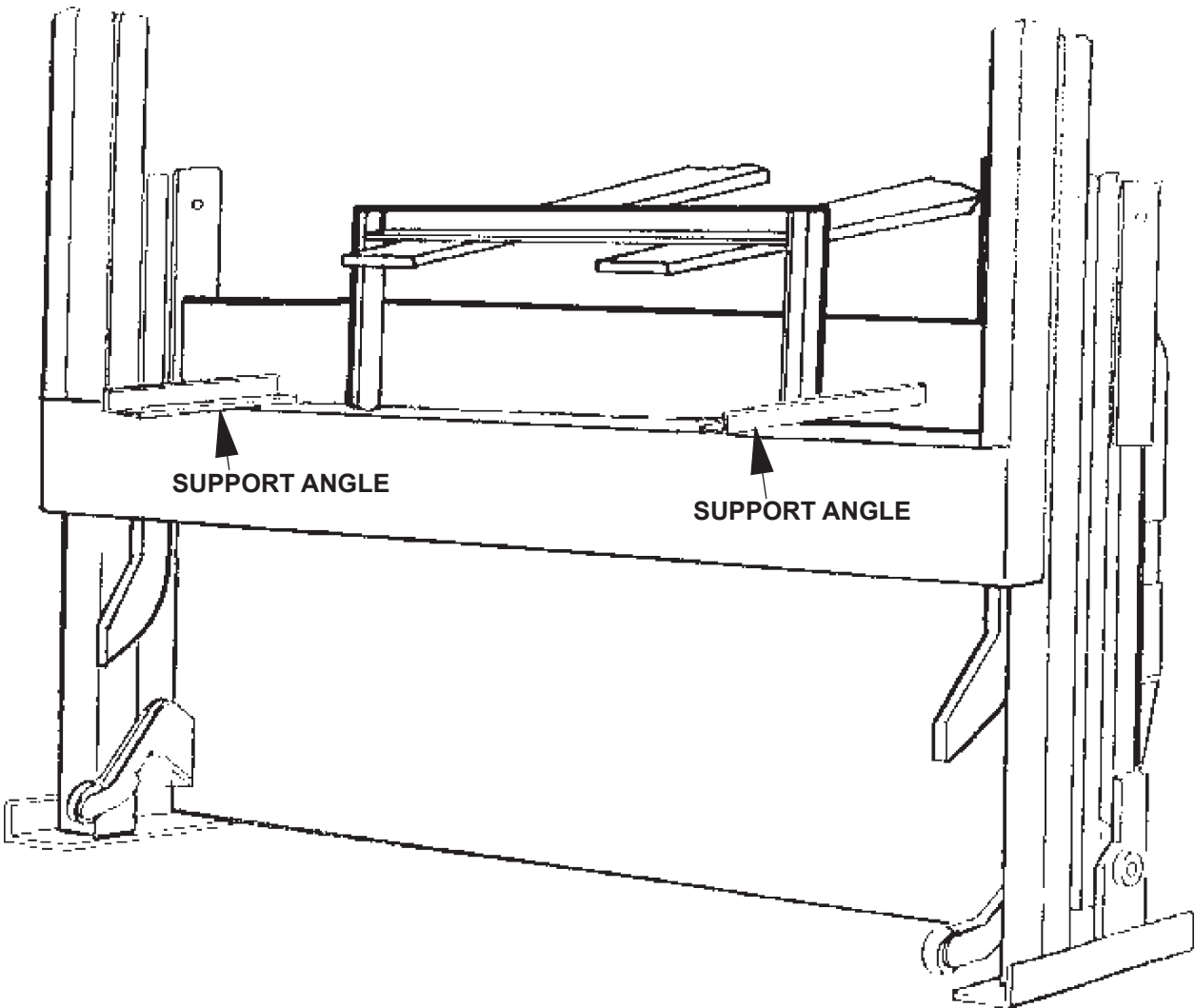

INSTALLATION OF UNIT - Continued

Corner posts and sill under rear of floor must be clean and free of any obstructions so that the columns of the rail lift can fit flat against the rear of the body.

Chalk mark a center line at the edge of the rear of the truck floor to line up with the mark on the liftgate.

Using the lifting straps, the unit can now be raised either with a chain hoist or fork lift to a height which will allow the temporary support angles to rest on the body floor. The unit can be moved to the vehicle or the vehicle to the unit till they meet.

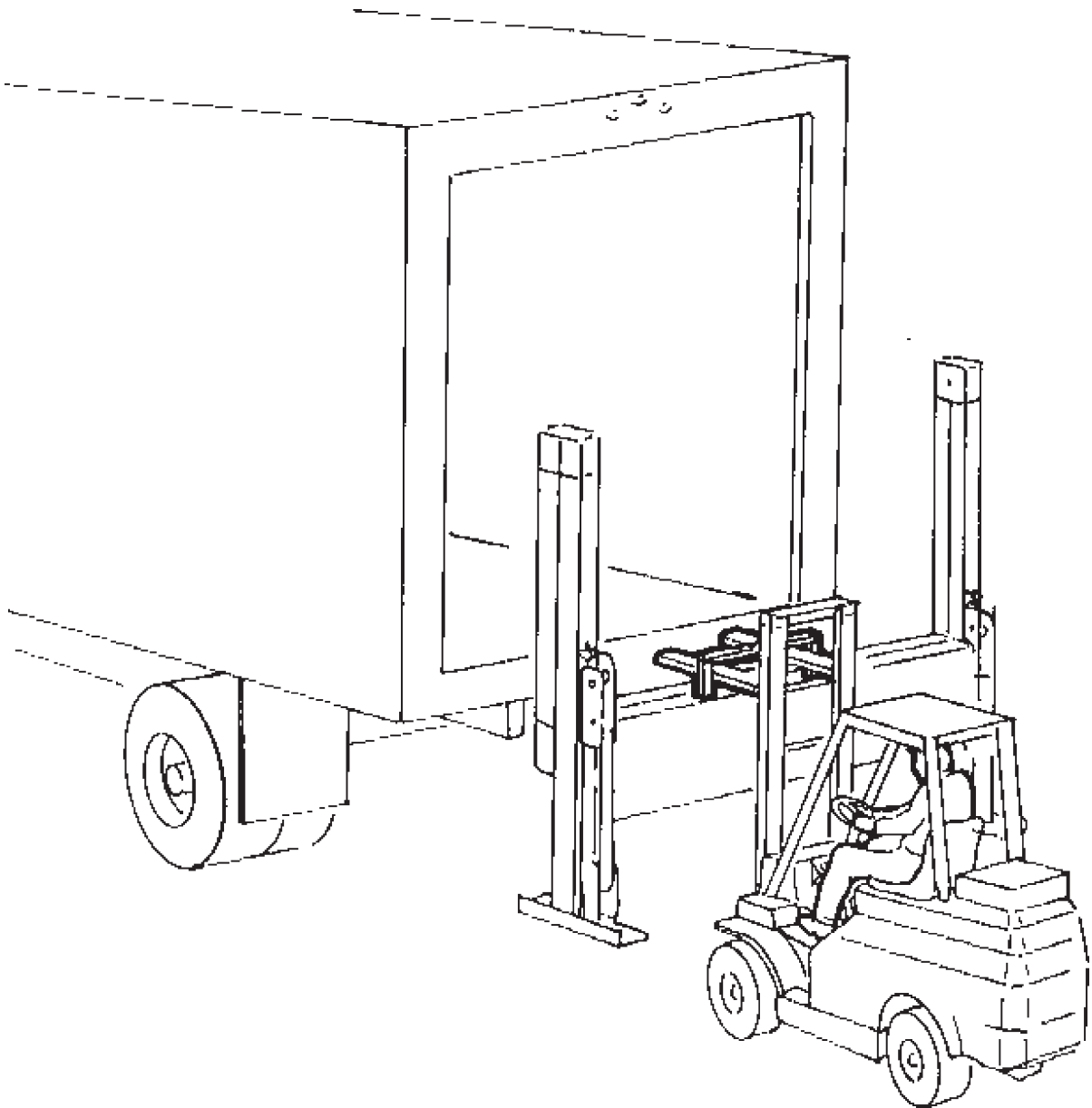

INSTALLATION OF UNIT - Continued

Clamp columns to the truck body and weld as shown. Remove forklift or chain hoist.

RC-2000/3000/RC-CR3

1/4" Fillet Weld. 2" Long

RC-4000

1/4" Fillet Weld. 3" Long

RC-5000/6000

1/4" Fillet Weld. 4" Long

NOTE: See views A & B on next page.

ALL UNITS: 1/8" fillet weld
approx. halfway
down the column.

ALL UNITS: See view C on
the next page.

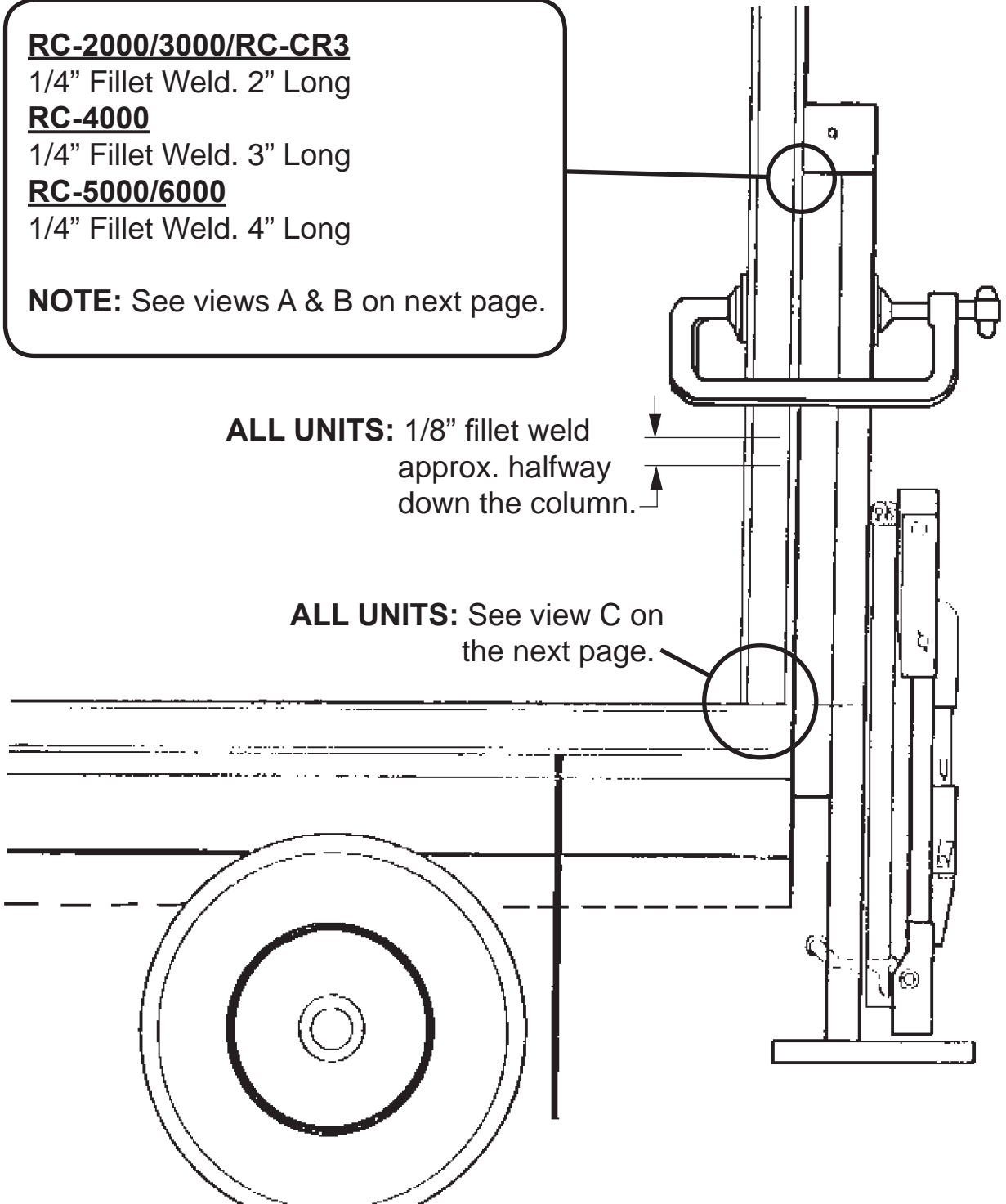

INSTALLATION OF UNIT - Continued

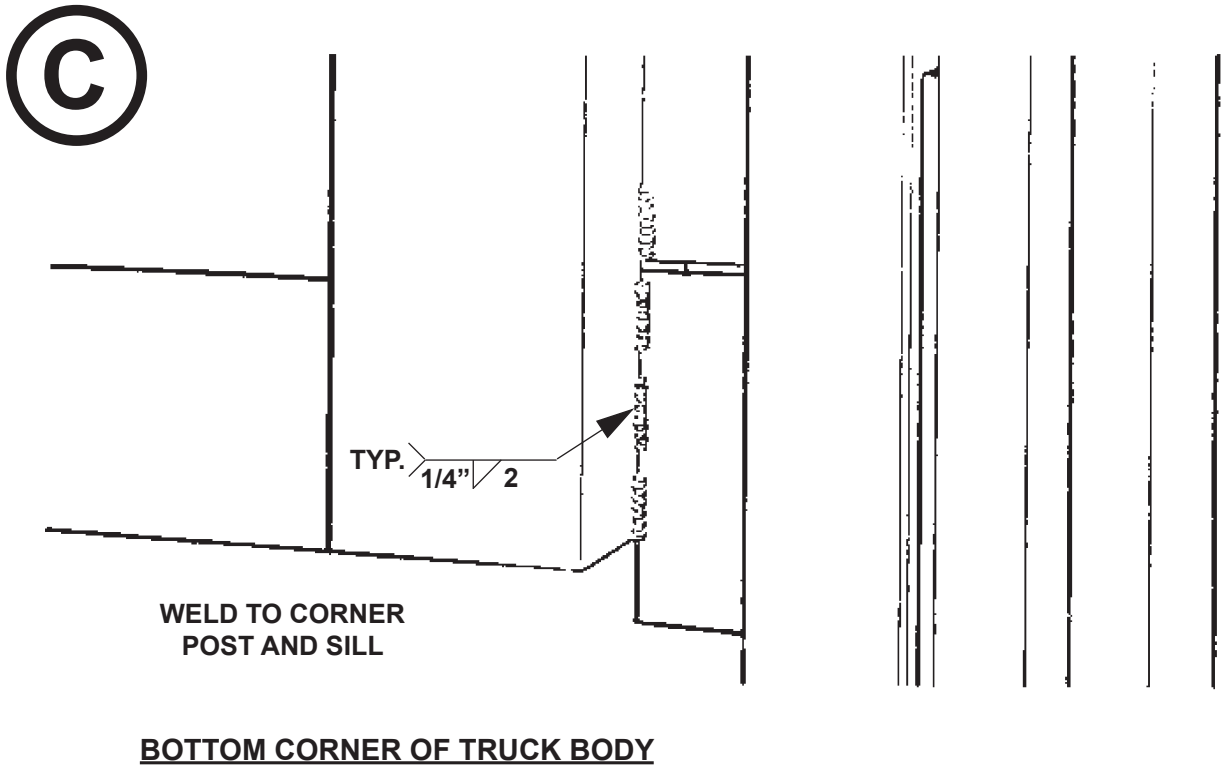
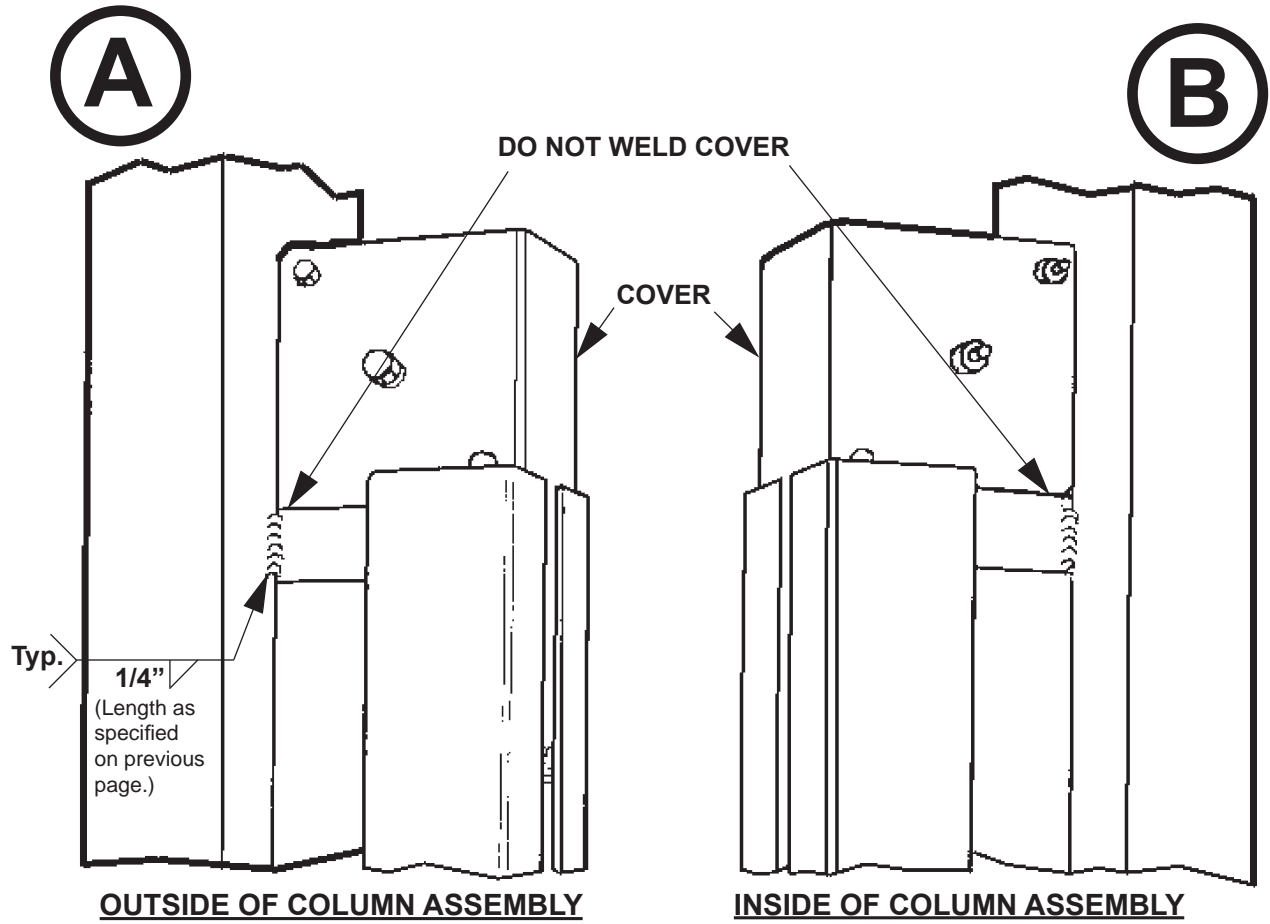

MAXON® 11921 Slauson Ave. Santa Fe Springs, CA. 90670 (800) 227-4116 FAX (888) 771-7713

INSTALLATION OF UNIT - Continued

Cut columns off 20" from ground. Place the 2-1/2" x 18" angle iron provided under at least 2 cross members, to prepare for the following step and weld.

Cut one end of each of the 4 foot long angle iron braces so that it lines up with the lift column and the other end lays flat against the angle iron referred to in the previous paragraph.

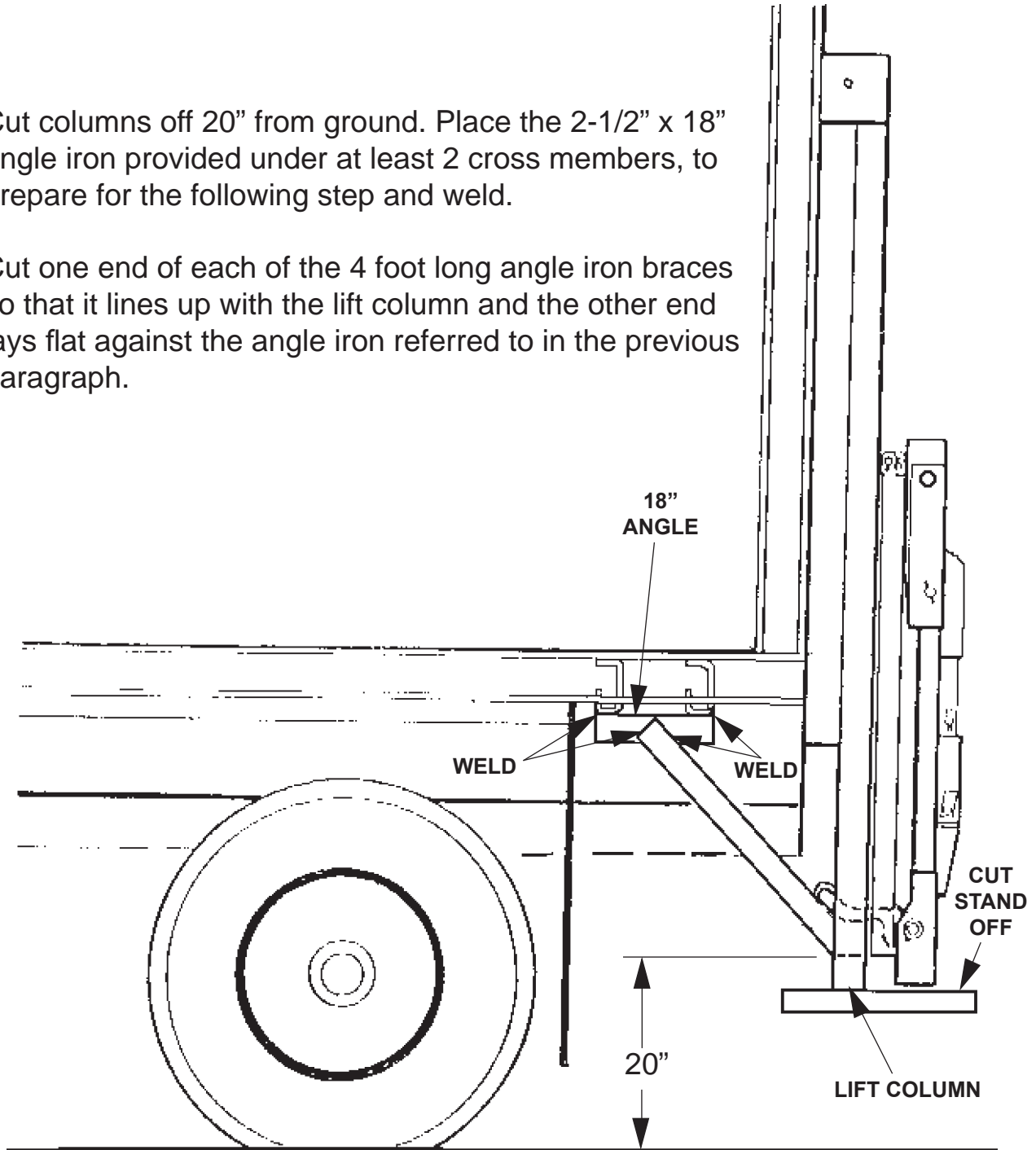

WELDING TO FLATBED

The column assemblies are tied in to the flat bed side rails with two lengths of channel. The required sizes are listed below.

NOTE: Mounting Channel is not supplied by Maxon

RC-2000/3000/4000

3" of 1/4" fillet weld

RC-5000/6000

4" of 1/4" fillet weld

RC-2000/3000/4000

3"-4.1 #/ft. Channel

RC-5000/6000

4"-5.4 #/ft. Channel

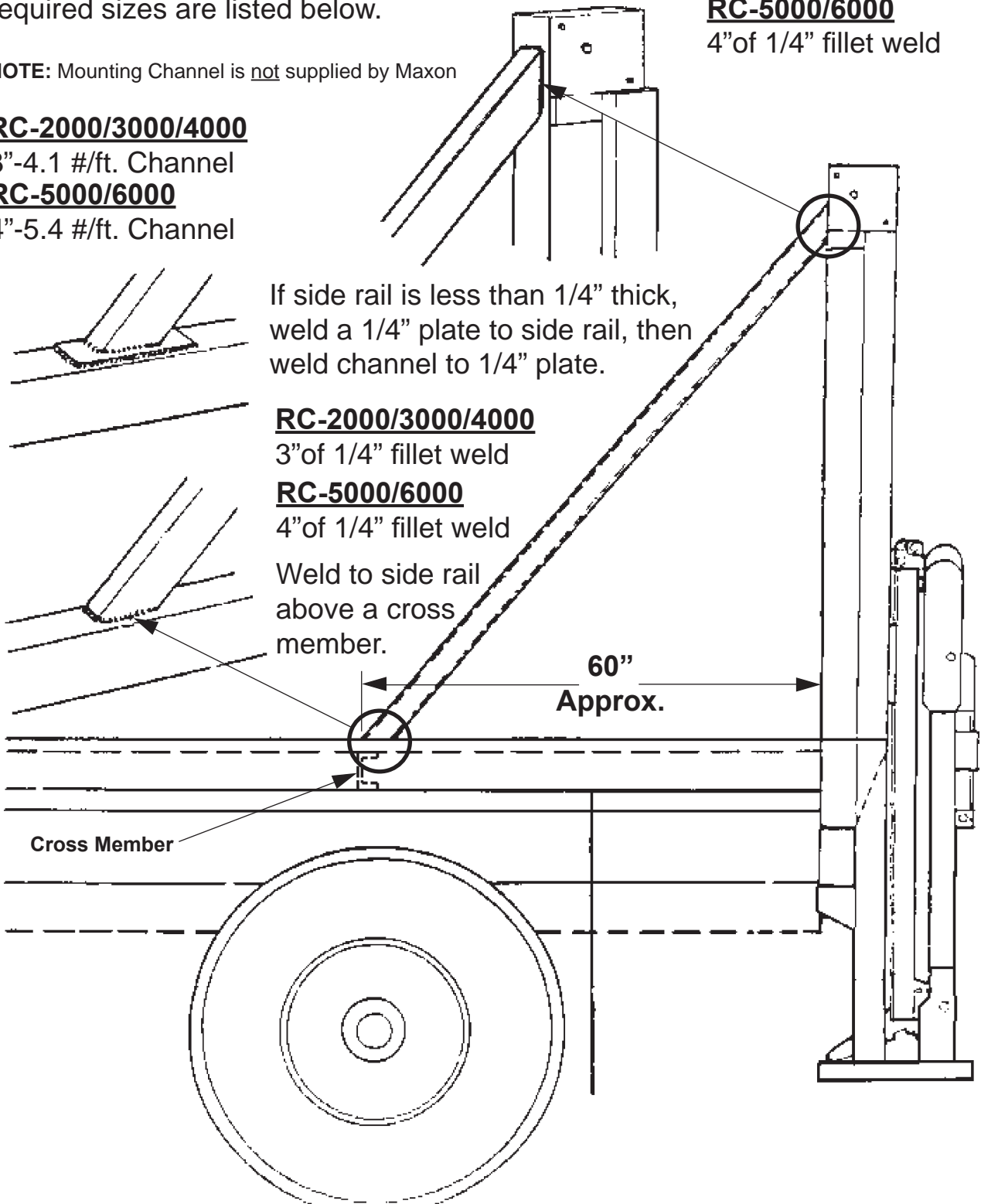

MAXON® 11921 Slauson Ave. Santa Fe Springs, CA. 90670 (800) 227-4116 FAX (888) 771-7713

HYDRAULIC PIPE INSTALLATION

Remove the seven foot long pipe that is strapped to this column of the lift gate (two pipes if lift has hydraulic platform closer), and weld to under side of floor cross members. End of pipe to be about two feet from the end of the truck body. Connect the four foot hoses to the end of the pipe(s) closest to the power unit and the other end through the pump box to the pump assembly. See the last page of "Power Pak Installation" for details.

NOTE: Blow air through pipes and hoses before connections are made.

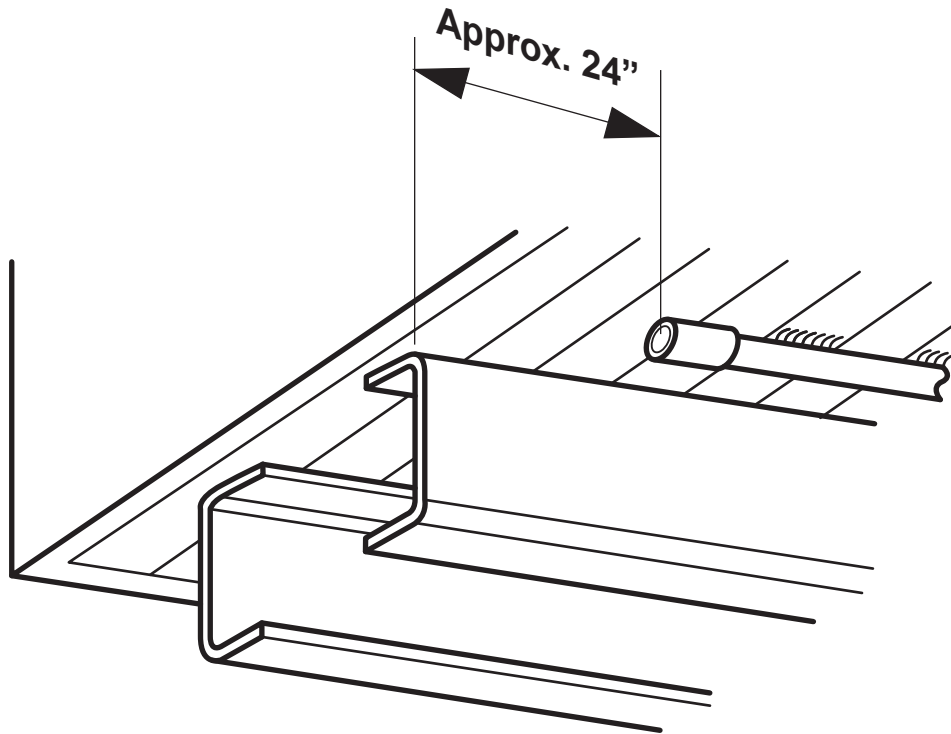

ATTACH OPTIONAL BATTERY BOX & FRAME TO VEHICLE (IF EQUIPPED)

1. Select holes on top of battery box frame to align mounting brackets flush to cross members. Refer to **FIGS. 13-1A & 13-1B** for trailers and **FIG. 13-2** for trucks. Bolt mounting brackets to battery box frame as shown in **FIG. 13-1C**. Torque each bolt and lock nut to **85-128 lb-ft.**

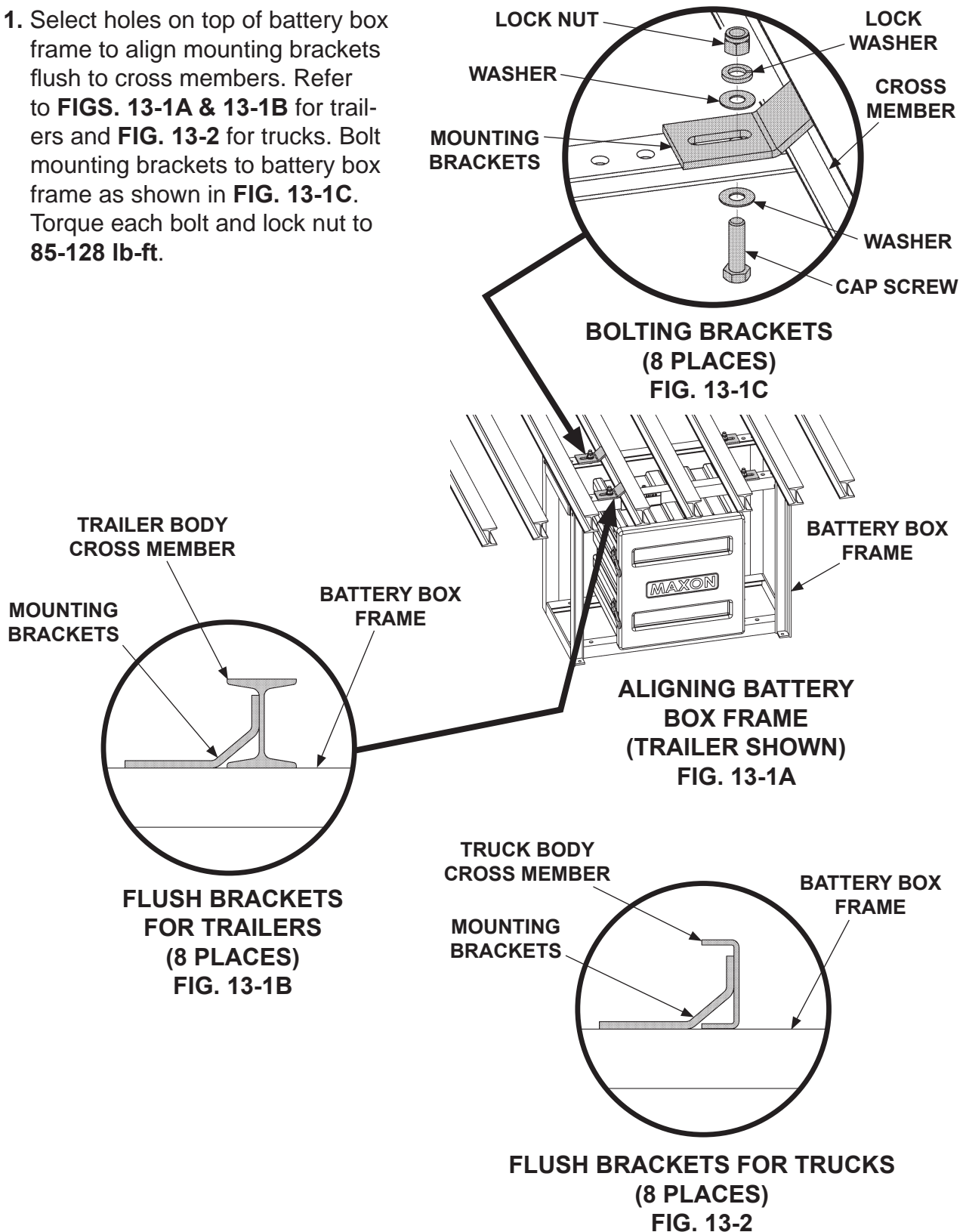

MAXON® 11921 Slauson Ave. Santa Fe Springs, CA. 90670 (800) 227-4116 FAX (888) 771-7713

ATTACH OPTIONAL BATTERY BOX & FRAME TO VEHICLE (IF EQUIPPED) - Continued

NOTE: If welding mounting brackets to cross members, skip instruction 2.

- Using mounting brackets as a template mark and drill holes through cross members (FIG. 14-1). Bolt mounting brackets to cross members as shown in FIGS. 14-2A and 14-2B. Torque bolts and lock nuts to 85-128 lb-ft.

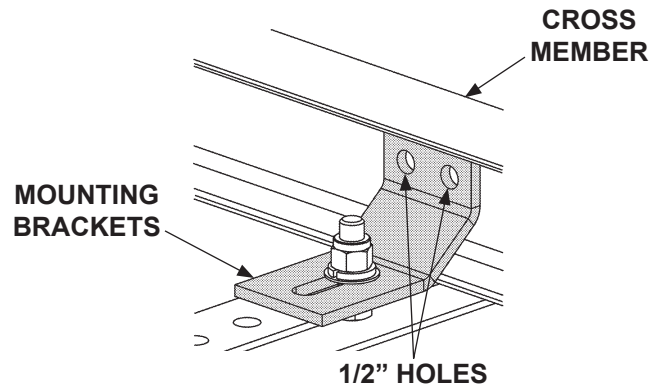

**MARK AND DRILL
FIG. 14-1**

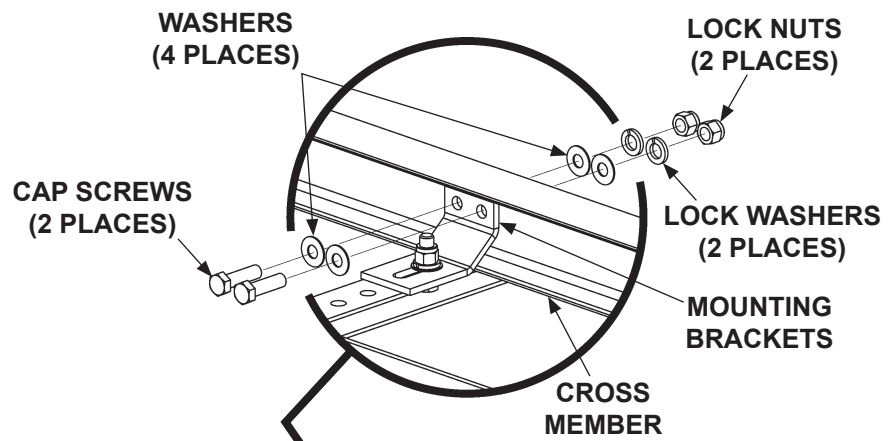

**BOLTING BRACKETS
(8 PLACES)
FIG. 14-2B**

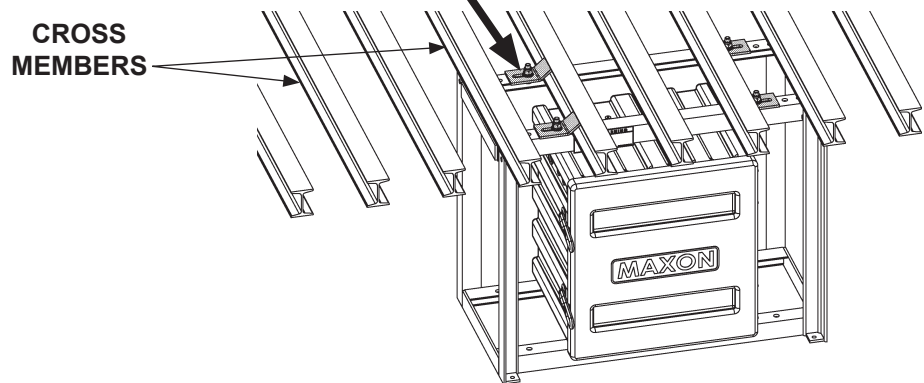

**BOLTING BATTERY BOX FRAME
FIG. 14-2A**

ATTACH OPTIONAL BATTERY BOX & FRAME TO VEHICLE (IF EQUIPPED) - Continued

⚠ WARNING

Recommended practices for welding on steel parts are contained in the current AWS (American Welding Society) D1.1 Structural Welding Code - Steel. Damage to Liftgate and/or vehicle, and personal injury can result from welds that are done incorrectly.

CAUTION

To prevent pump box components from being damaged by electric current from welding, connect welder grounding cable to the part being welded.

CAUTION

Cover pump box and optional battery box with flame-resistant covering before welding pump box frame to vehicle.

- For galvanized frame, read warning decal shown in **FIGS. 15-1A** and **FIGS. 15-1B** before welding. Weld each bracket to cross members as shown in **FIGS. 15-1A** and **15-1C**. Weld top of bracket if accessible.

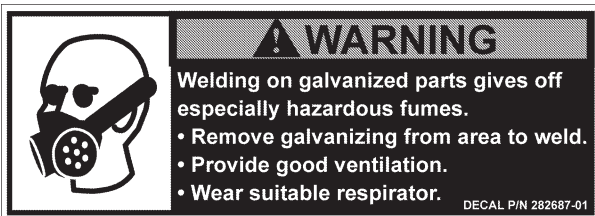
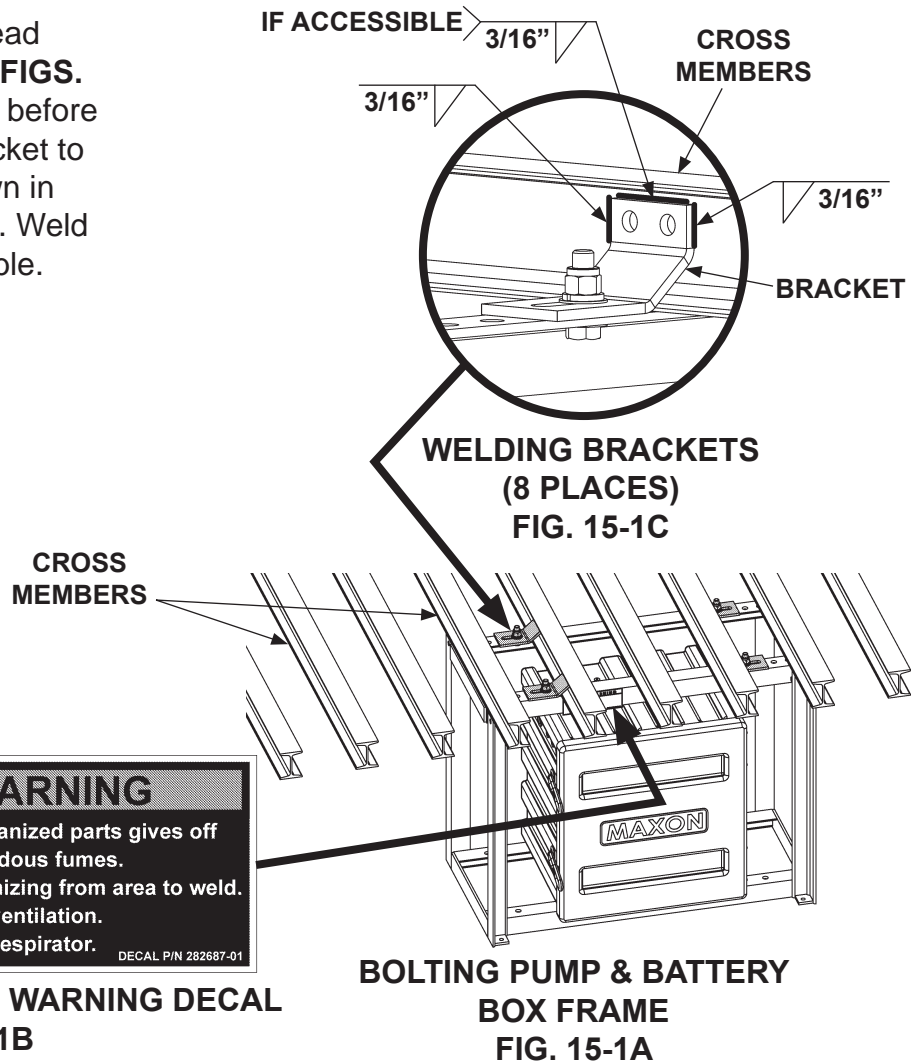

WELDING GALVANIZED, WARNING DECAL
FIG. 15-1B

BOLTING PUMP & BATTERY
BOX FRAME
FIG. 15-1A

ATTACH OPTIONAL BATTERY BOX & FRAME TO VEHICLE (IF EQUIPPED) - Continued

⚠ WARNING

Remove all rings, watches and jewelry before doing any electrical work.

NOTE: Always connect fused end of power cable to battery positive (+) terminal.

NOTE: To connect charge lines, refer to instructions provided with each charge line kit.

NOTE: MAXON recommends using dielectric grease on all electrical connections.

4. Connect battery cables, fused cables, and ground cables as shown in **FIG. 16-1**.

ELECTRICAL COMPONENTS - BATTERY BOX

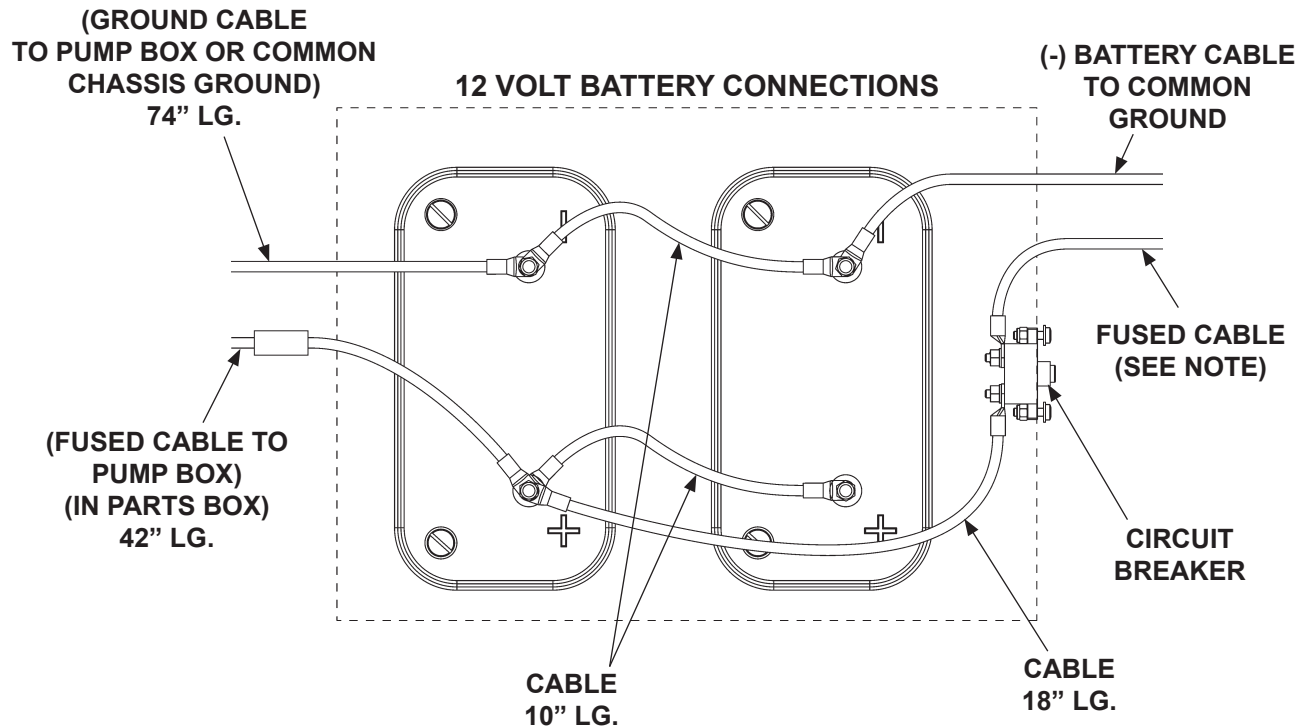
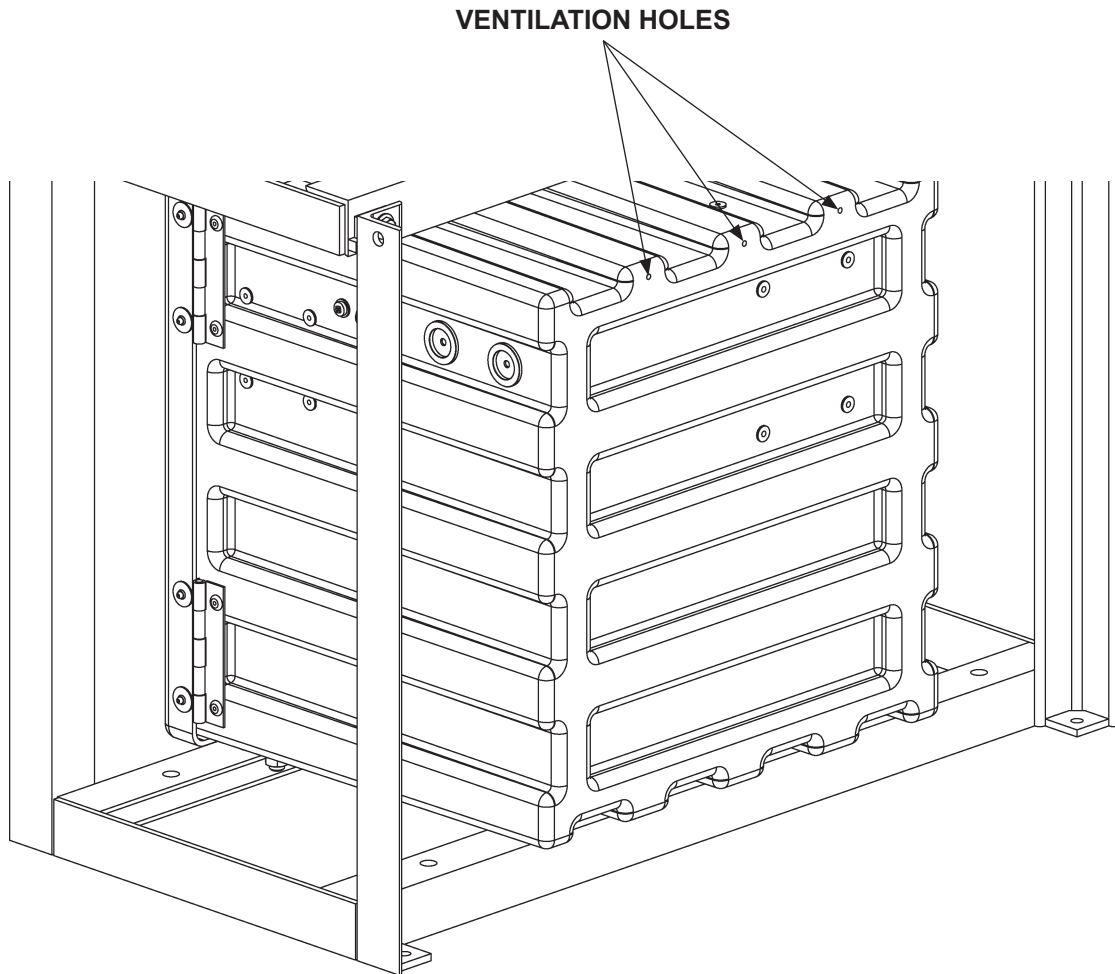

FIG. 16-1

ATTACH OPTIONAL BATTERY BOX & FRAME TO VEHICLE (IF EQUIPPED) - Continued

⚠ WARNING

Explosive hydrogen gas from charging batteries can accumulate in battery box if not vented from the box. To prevent hydrogen gas from accumulating, ensure the 3 ventilation holes in battery box are not plugged or covered.



**BATTERY BOX ASSEMBLY
(REAR VIEW SHOWN)
FIG. 17-1**

ATTACH OPTIONAL BATTERY BOX & FRAME TO VEHICLE (IF EQUIPPED) - Continued

BATTERY BOX ASSEMBLY

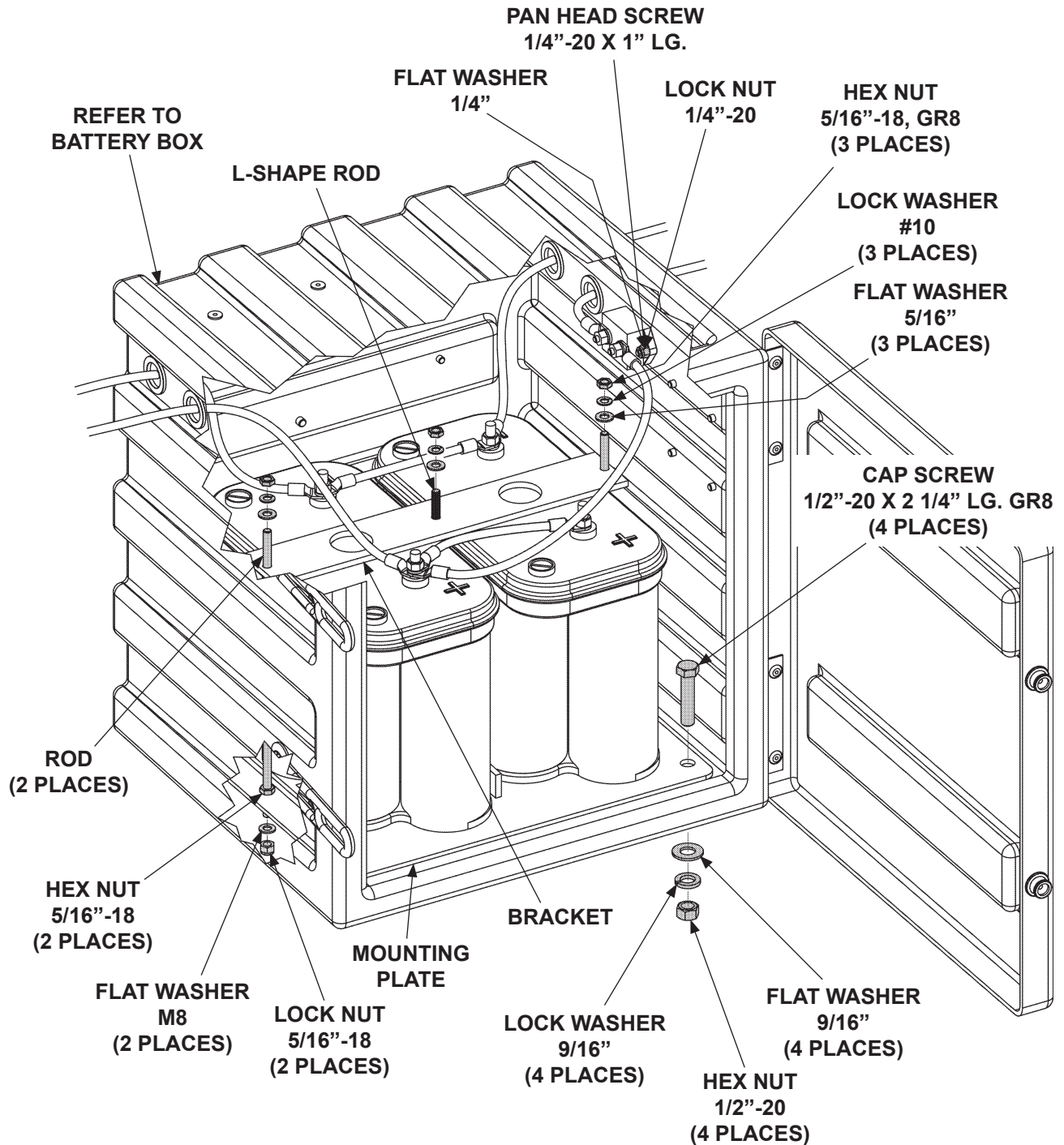
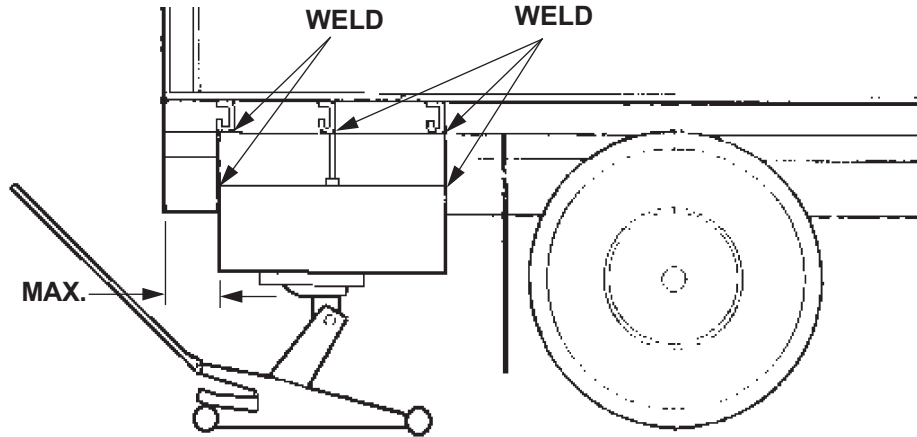

FIG. 18-1

POWER PACK INSTALLATION

TRUCK BODIES

Jack up the steel box containing the pump assembly until it touches at least two cross members under the floor, three if possible, and the back of the box touches the truck chassis frame. Weld where instructed and remove jack. Leave room for tail lights.



TRAILER BODIES

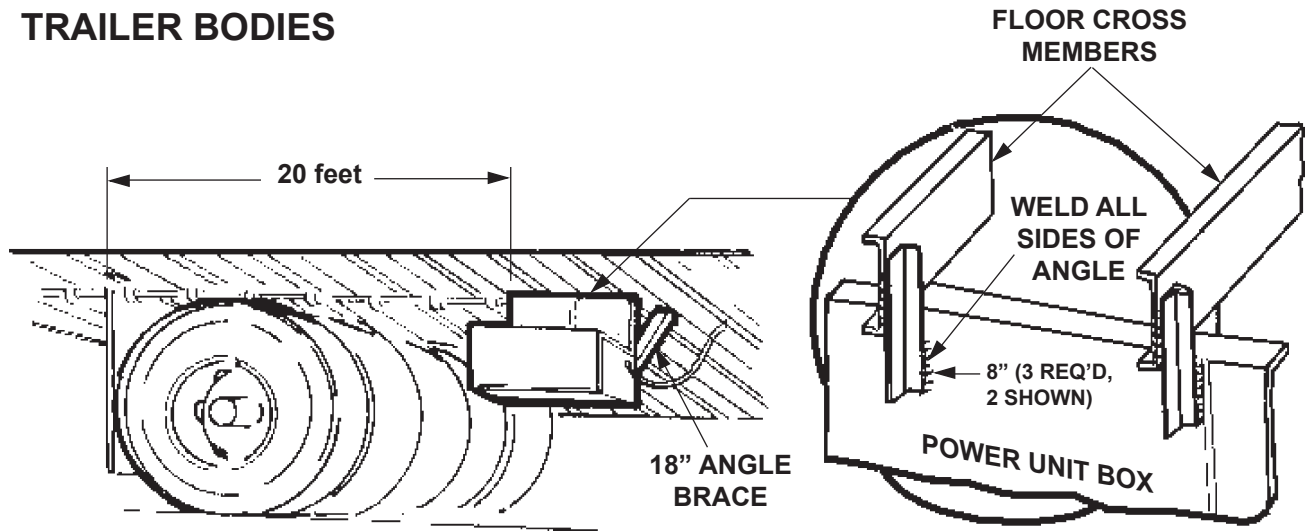

Jack up the steel box containing the pump assembly until it touches at least two cross members under the floor, three if possible and tack weld. Add braces provided to the back of the box and the side of the floor cross members. Weld both ends of braces and top of box. Use short pieces of angle iron provided to weld from the side of the floor cross members to the front of the box.

Make sure the box is not in a position to interfere with the wheels of the trailer with sliding axle.

Box can also be placed behind the wheels if room permits.

POWER PACK INSTALLATION - Continued

Run 32 ft. power cable from the pump box, along the chassis frame to the positive terminal of the battery (assuming the negative is ground). Use frame clips to secure the cable. (Do not attach to the battery terminal until the other end is fastened on the pump). If the cable is too long, cut to proper length.

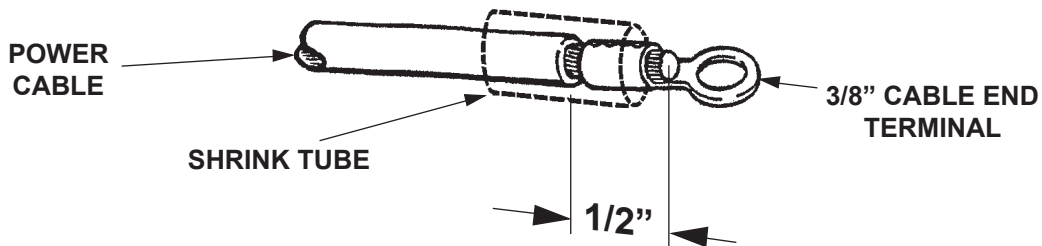

Strip about 1/2" of the insulation from the end and slide one of the pieces of shrink tube far enough down that it's out of your way. Solder the terminal end firmly onto the cable.

Always wear protective eye covering while you are doing soldering operations.

When it's cool, slide the shrink tube over the terminal end and heat with a heat gun til it shrinks tightly over the cable and terminal.

NOTE:

Proper cable connections are extremely important to insure a long and efficient life to all electrical components, therefore, solder type terminals, solder and shrink tubing are provided to insure proper connections. Please do not use the hammer smashing method since the constant bouncing and vibration of the vehicle can eventually cause these types of joints to loosen and deteriorate.

This could also be true of crimping if not done properly or the wrong size tool is used.

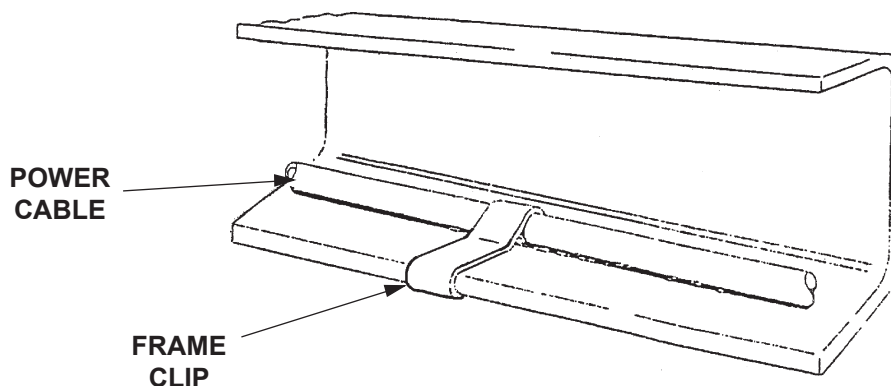

POWER PACK INSTALLATION - Continued

TRUCKS ONLY

Route the two hoses (3 if hydraulic closer) and the three conductor cord (two cords if hydraulic closer), that come out of the bottom of the lift gate main frame through the power pak box and connect as shown.

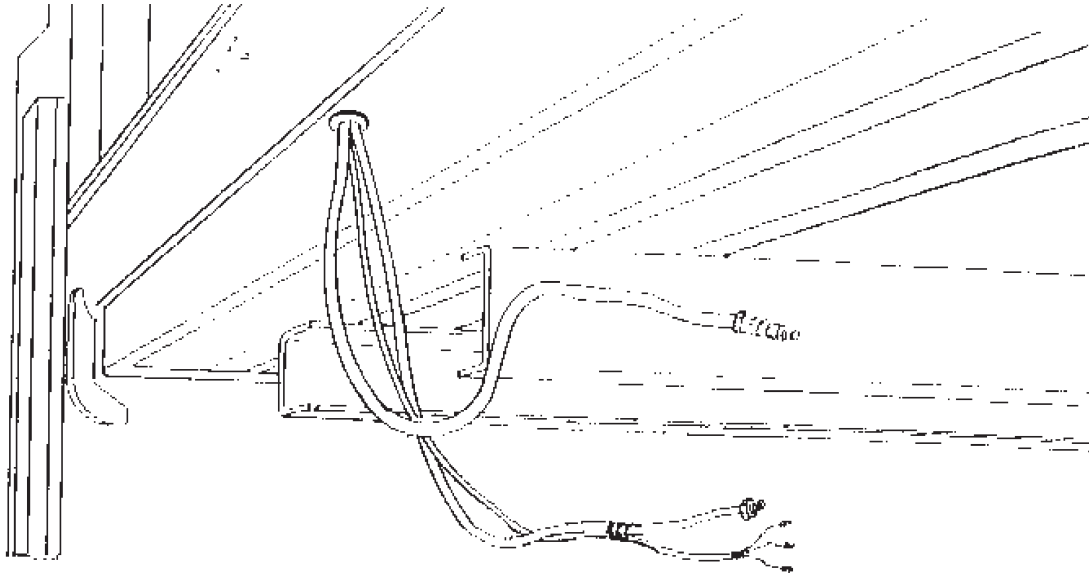

TRAILERS ONLY

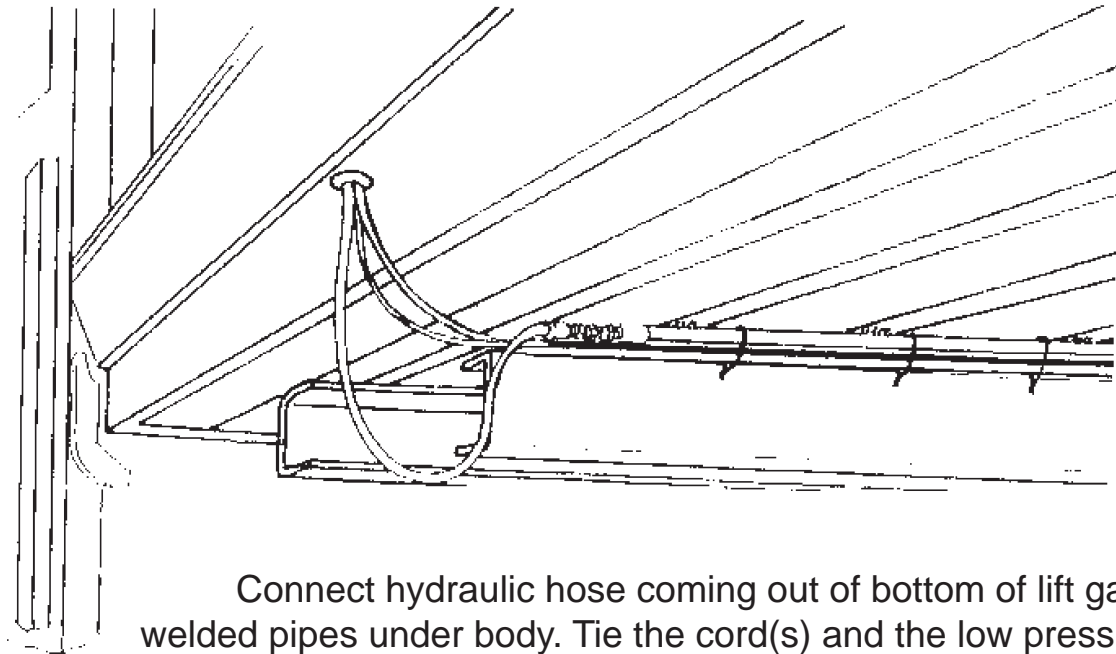



Connect hydraulic hose coming out of bottom of lift gate to welded pipes under body. Tie the cord(s) and the low pressure line to the pipe and route through power unit box.

FUSED POWER CABLE

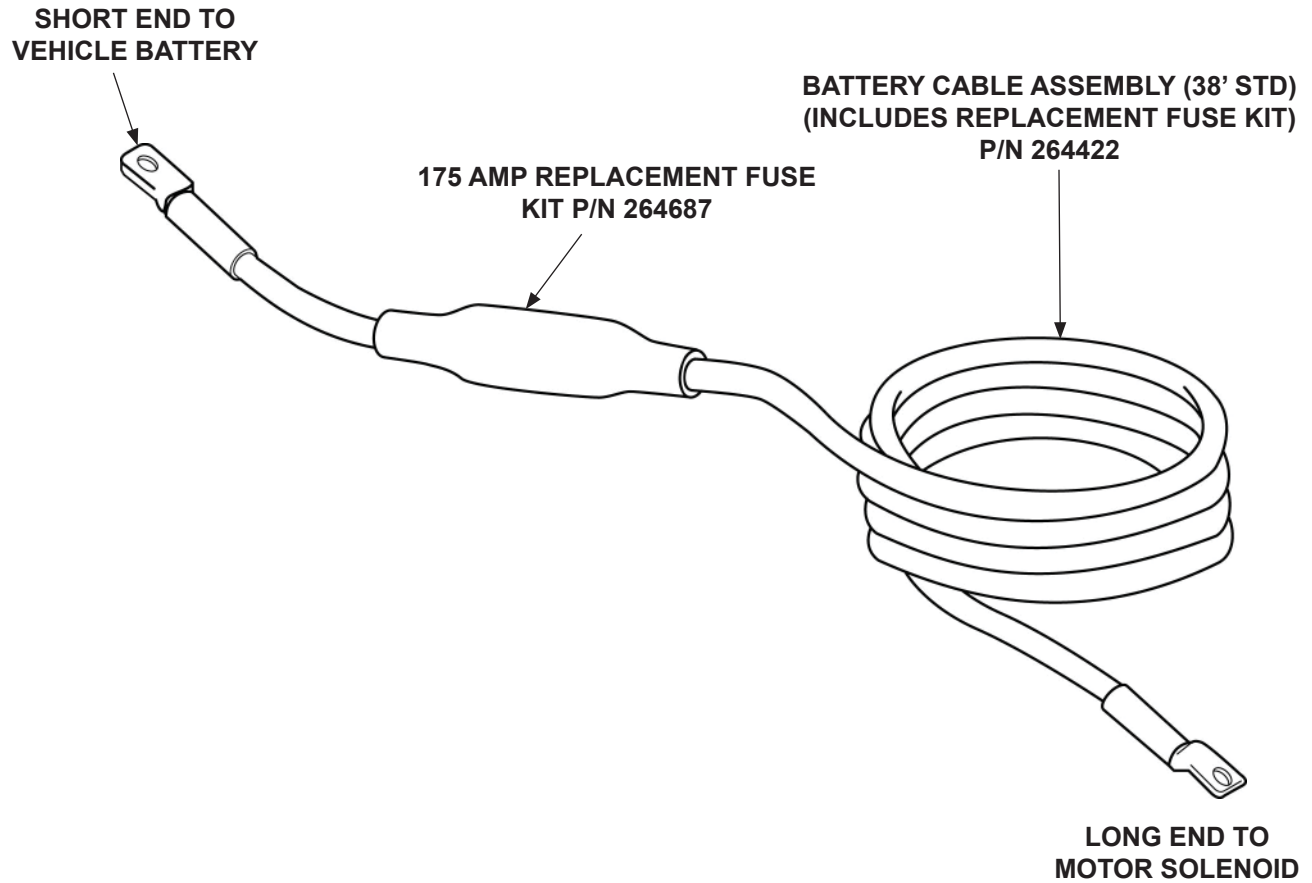
⚠ WARNING
 Do not attach cable to battery until Liftgate is completely installed.



OPTIONAL POWER CABLE KITS		
DESCRIPTION	PART NUMBER	FIGURE
40' CABLE ASSEMBLY (WITH 200 AMP FUSE)	264848	(CABLE ASSEMBLY) 
10' EXTENSION CABLE ASSEMBLY	264849	(EXTENSION CABLE ASSEMBLY) 

MAXON® 11921 Slauson Ave. Santa Fe Springs, CA. 90670 (800) 227-4116 FAX (888) 771-7713

PUMP WIRING CAM CLOSER

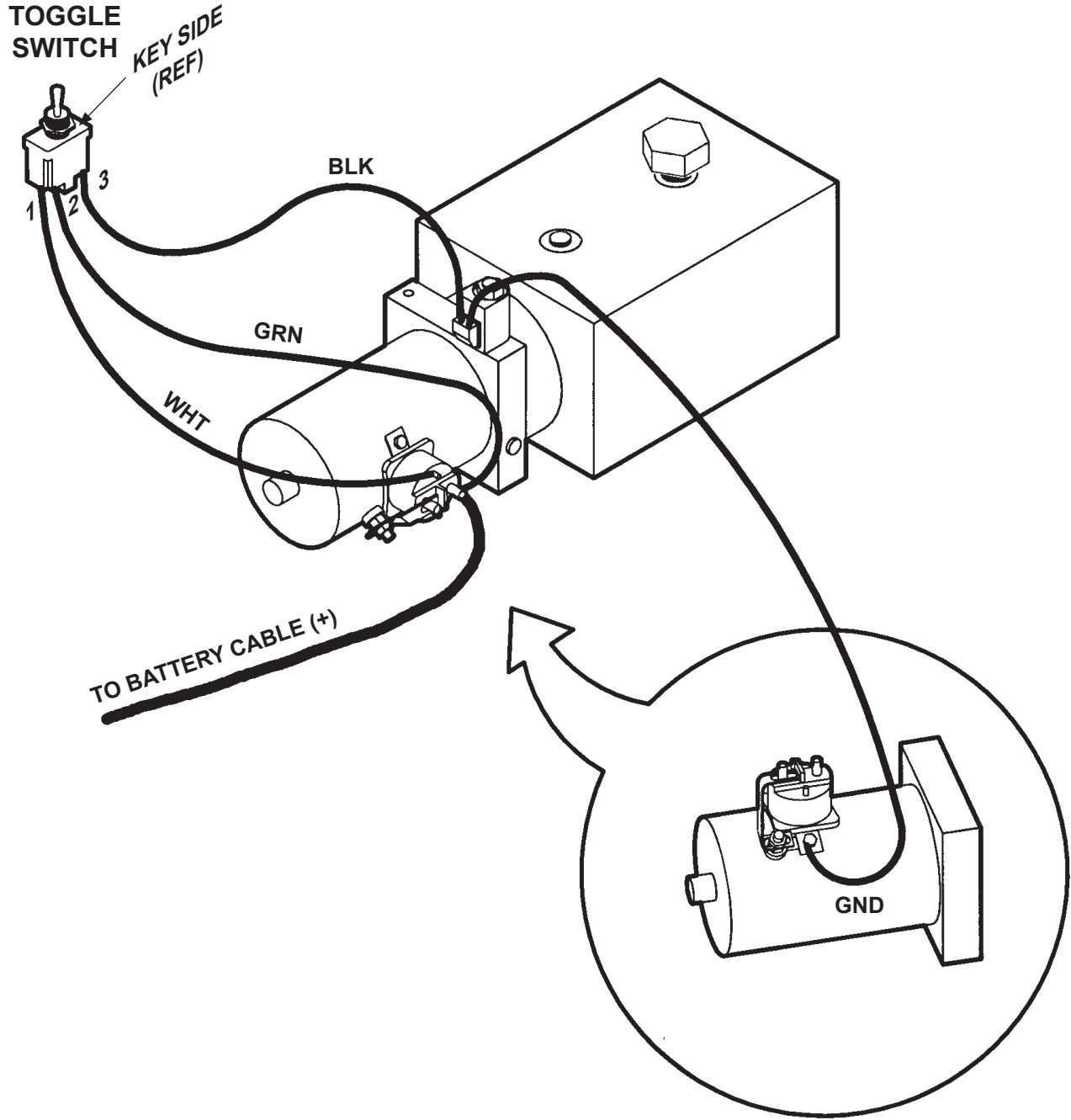

	POWER TO
UP	WHT.
DOWN	BLK.

ADD HYDRAULIC FLUID

CAUTION

Keep dirt, water and other contaminants from entering the hydraulic system. Before opening the hydraulic fluid reservoir filler cap, drain plug and hydraulic lines, clean up contaminants that can get in the openings. Also, protect the openings from accidental contamination.

NOTE: Use correct grade of hydraulic fluid for your location.

+50 to +120 Degrees F - Grade ISO 32

Below + 70 Degrees F - Grade ISO 15 or MIL-H-5606

See **TABLES 26-1 & 26-2** for recommended brands.

1. Open pump box cover (**FIG. 25-1**).

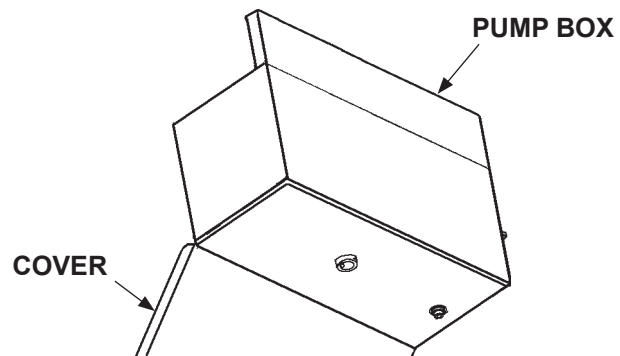

2. Remove the filler cap (**FIG. 25-1**). Add 4 quarts of hydraulic fluid to reservoir. (Refer to the **NOTE** above.)

PUMP BOX WITH OPEN COVER
FIG. 25-1

3. Reinstall filler cap (**FIG. 25-2**).

NOTE: To check oil level in the pump reservoir, platform must be at ground level.

4. When Liftgate is ready to operate, unfold and lower the platform to ground level. (See **Operation Manual**.)
5. Remove the filler cap (**FIG. 25-2**). Check if hydraulic fluid is at the top of the **GRAVITY DOWN** bar on the decal (**FIG. 25-1**). If necessary, add fluid to the top of the bar.

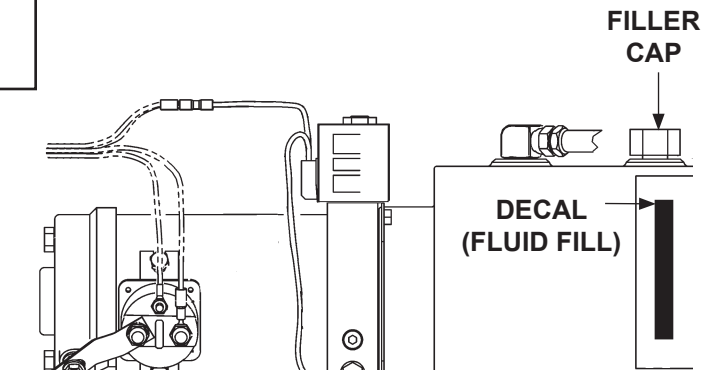

CHECKING FLUID LEVEL
(GRAVITY DOWN PUMP SHOWN - USED ON
RC WITH CAM PLATFORM CLOSER)
FIG. 25-2

6. Reinstall filler cap (**FIG. 25-2**).

ADD HYDRAULIC FLUID - Continued

ISO 32 HYDRAULIC OIL	
RECOMMENDED BRANDS	PART NUMBER
AMSOIL	AWH-05
CHEVRON	HIPERSYN 32
KENDALL	GOLDEN MV
SHELL	TELLUS S2 V32
EXXON	UNIVIS N-32
MOBIL	DTE-13M, DTE-24, HYDRAULIC OIL-13

TABLE 26-1

ISO 15 OR MIL-H-5606 HYDRAULIC OIL	
RECOMMENDED BRANDS	PART NUMBER
AMSOIL	AWF-05
CHEVRON	FLUID A, AW-MV-15
KENDALL	GLACIAL BLU
SHELL	TELLUS S2 V15
EXXON	UNIVIS HVI-13
MOBIL	DTE-11M
ROSEMEAD	THS FLUID 17111

TABLE 26-2

FINAL ADJUSTMENTS

Fill the system with fluid by activating the raise control switch until the runners hit the stops.

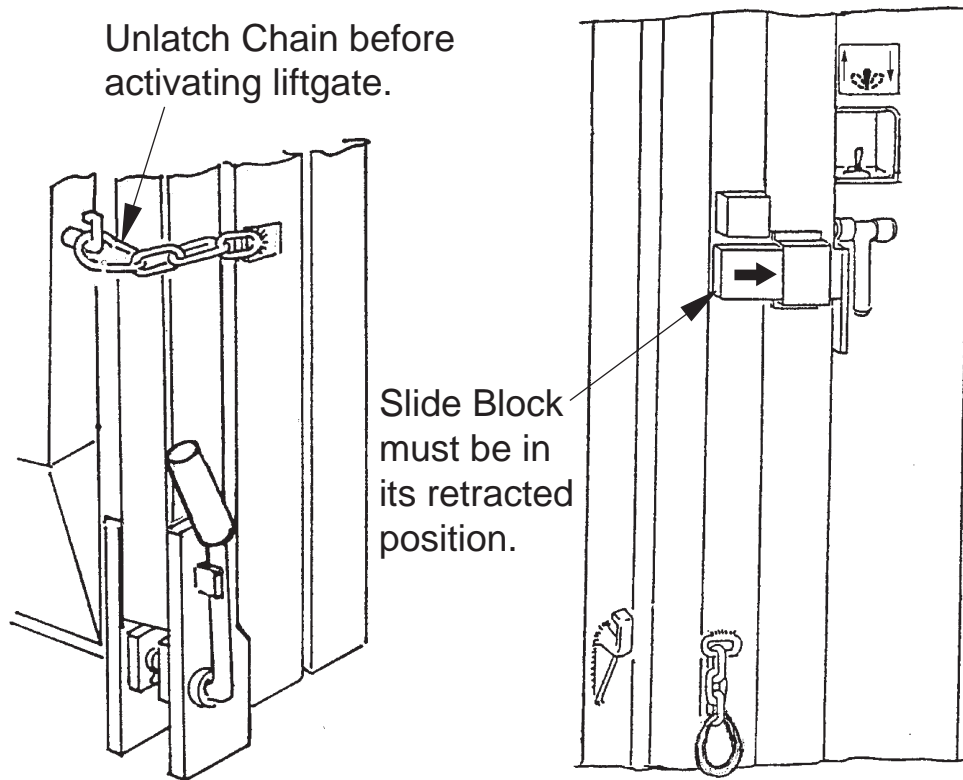

Remove platform holding chain and activate switch to let unit down until platform rests on ground.

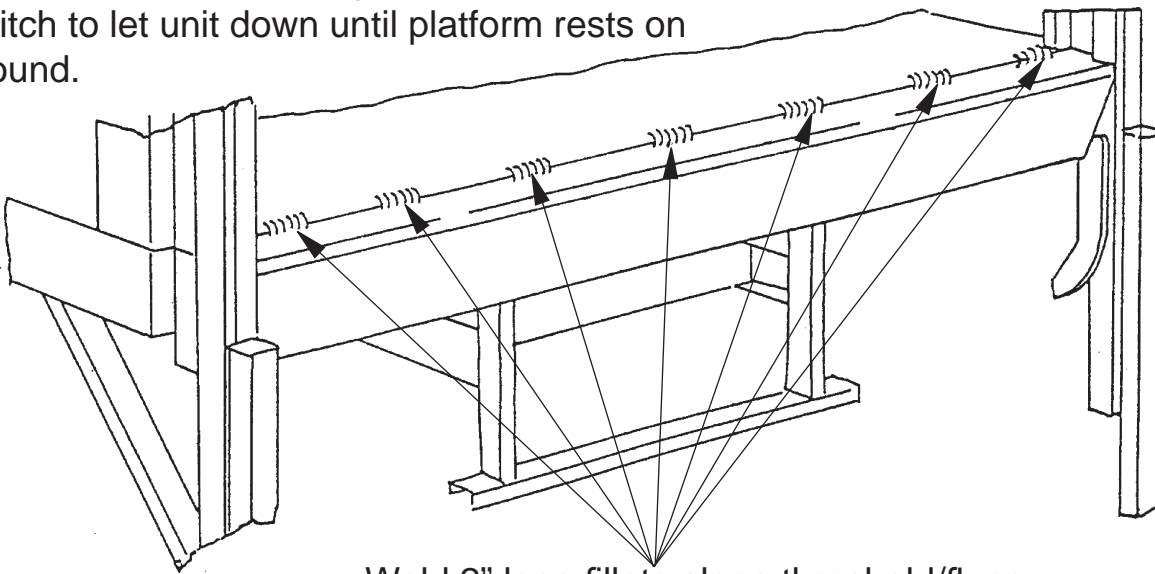

Weld 2" long fillets along threshold/floor about every 8 to 10 inches. No welding is necessary on the bottom.

FINAL ADJUSTMENTS - Continued

Adjust flow control valve (**FIG. 28-1**) on power pack so platform does not open too slowly or too quickly from stowed position.

- Platform will make a banging noise if it opens too quickly.
- In 55°F to 95°F temperature range and with platform observed to be lowering at normal speed, platform opening time should be in range of 4 to 6 seconds.
- If temperatures are below 55°F and valve setting is the same, it may take longer for platform to open.

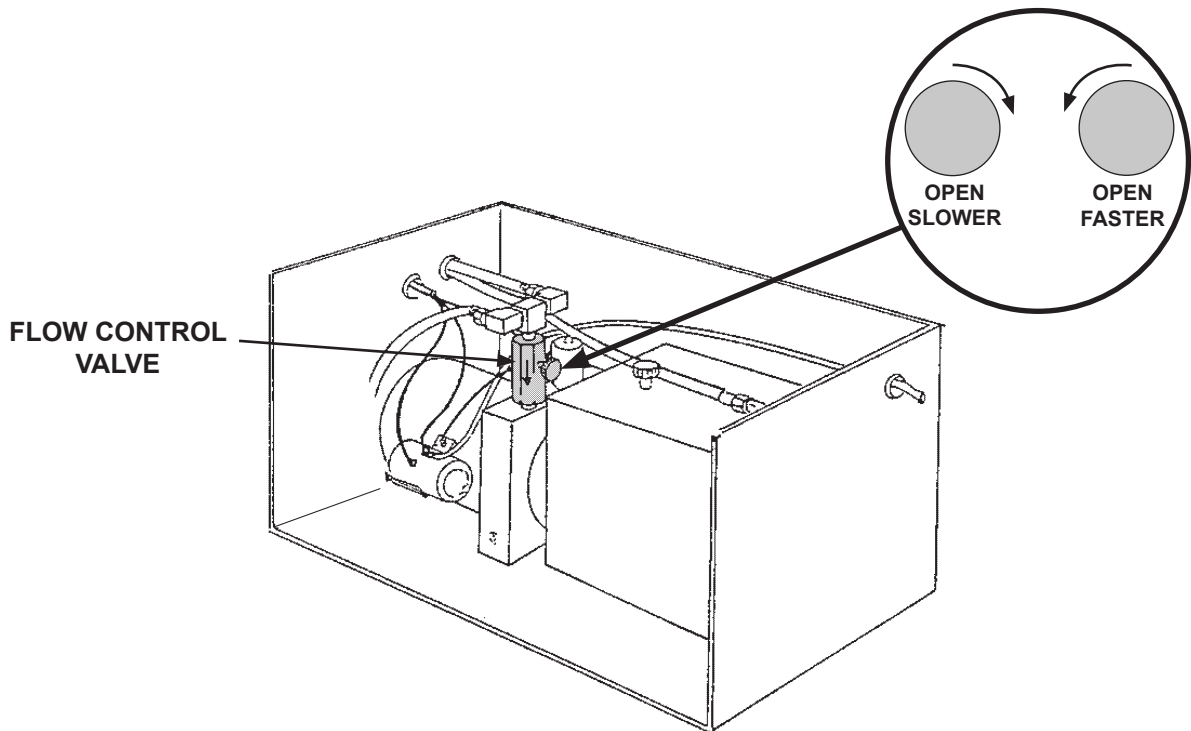

**ADJUSTABLE FLOW CONTROL VALVE
(POWER PACK FOR CAM CLOSER RC IS SHOWN)**

FIG. 28-1

To ensure that the platform brakes are working properly, perform the following simple test:

1. Open Platform and let unit down so that the bottom of the Runner on one side rests on a floor jack.
2. Raise the jack about 3" or so and let the jack down.
3. The Runner should stay in the jacked-up position. If it falls down to its original position resting on the jack, then the brake is not working and must be checked.
4. To release engaged brake, raise unit.

Perform test on opposite side as well.

If platform raises unevenly from side to side, adjust per instructions in maintenance manual. Install lights and add decals.

ATTACH DECALS

NOTE: Ensure there is no residue, dirt, or corrosion where decals are attached. If necessary, clean surface before attaching decals.

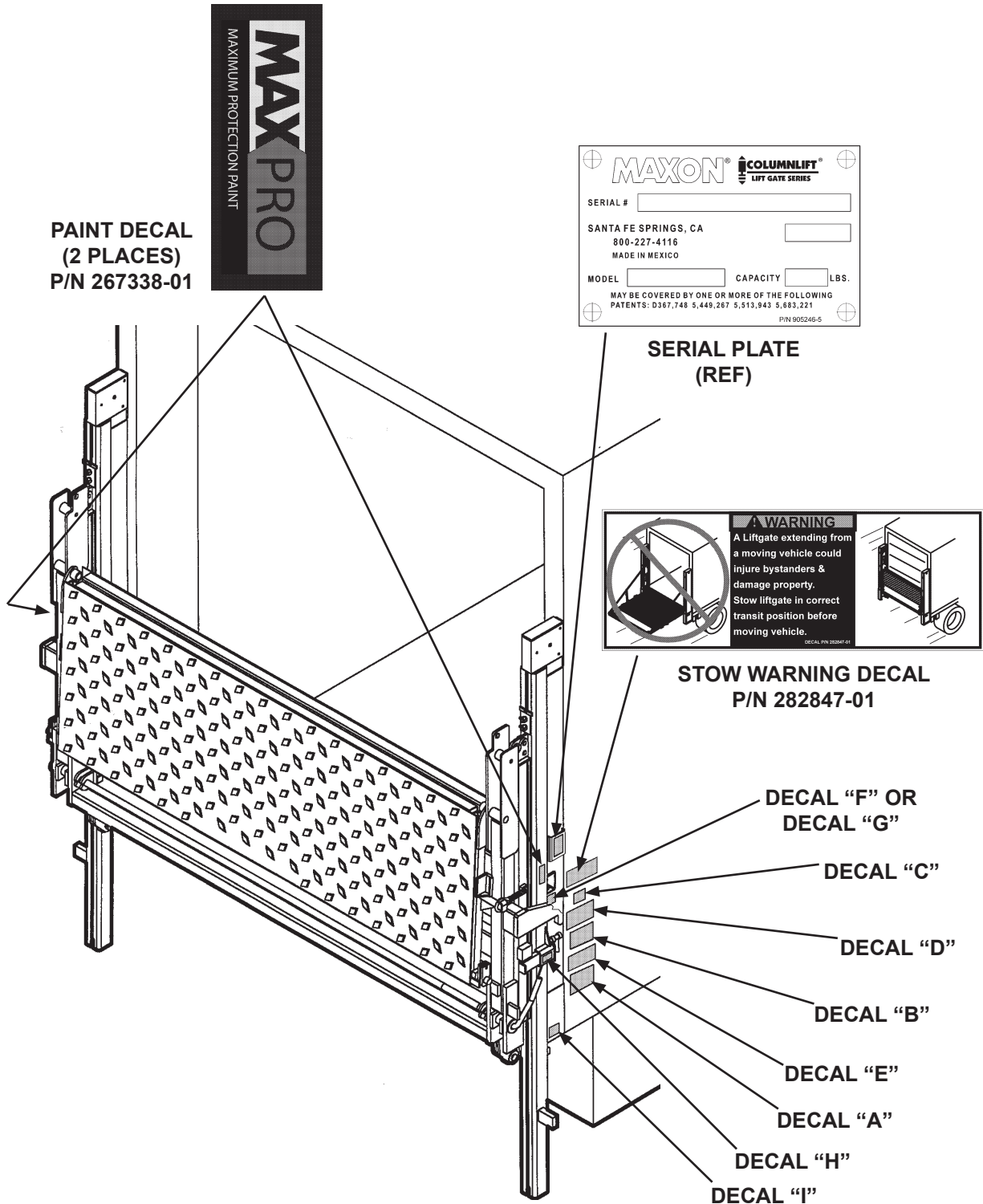

MAXON® 11921 Slauson Ave. Santa Fe Springs, CA. 90670 (800) 227-4116 FAX (888) 771-7713

SAFETY INSTRUCTIONS

Read all decals and operation manual before operating liftgate.

1. Do not use liftgate unless you have been properly instructed and have read, and are familiar with, the operating instructions.
2. Be certain vehicle is properly and securely braked before using the liftgate.
3. Always inspect this liftgate for maintenance or damage before using it. Do not use liftgate if it shows any sign of damage or improper maintenance.
4. Do not overload.
5. Make certain the area in which the platform will open and close is clear before opening or closing the platform.
6. Make certain platform area, including the area in which loads may fall from platform, is clear before and at all times during operation of liftgate.
7. This liftgate is intended for loading and unloading of cargo only. Do not use this liftgate for anything but its intended use.

(A)

WARNING

Read this information carefully.

- Improper operation of this Liftgate can result in serious personal injury. If you do not have a copy of the operating instructions, please obtain them from your employer, distributor, or lessor before you attempt to operate Liftgate.
- If there are signs of improper maintenance, damage to vital parts, or slippery platform surface, do not use the Liftgate until these problems have been corrected.
- If you are using a pallet jack, be sure it can be maneuvered safely.
- Do not operate a forklift on the platform.
- Do not allow any part of yours or your helper's body to be placed under, within, or around any portion of the moving Liftgate, or its mechanisms, or in a position that would trap them between the platform and the ground or truck when the Liftgate is operated.
- If a helper is riding the platform with you, make sure you are both doing so safely and that you are not in danger of coming in contact with any moving or potentially moving obstacles.
- **USE GOOD COMMON SENSE.**
- If load appears to be unsafe, do not lift or lower it.

For a free copy of other manuals that pertain to this model Liftgate, please visit our website at www.maxonlift.com or call Customer Service at (800) 227-4116.

(B)

THE MAXIMUM CAPACITY OF THIS LIFT IS

_____ POUNDS

WHEN THE LOAD IS CENTERED ON THE LOAD CARRYING PLATFORM

(C)

WARNING

Liftgate hazards can result in crushing or falling.

Keep hands and feet clear of pinch points.

If riding liftgate, make sure load is stable and footing is solid.



Read and understand all instructions and WARNINGS before use.

(D)

CAUTION

Always stand clear of platform area.

P/N 268386-01 (E)

CAUTION

To prevent damage, stow Liftgate under hydraulic pressure & push slide bar under stop. Never rest the stop on slide bar.

(H)

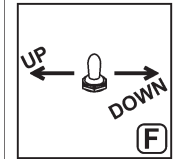

(F)

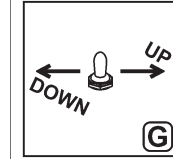

(G)

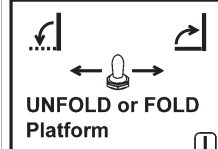

UNFOLD or FOLD Platform

(I)

(FOR HYDRAULIC CLOSER, ONLY)

DECAL SHEET

MODEL	ORDER P/N
RC-2 CAM CLOSER	268385-01
RC-3 CAM CLOSER	268385-02
RC-4 CAM CLOSER	268385-03
RC-5 CAM CLOSER	268385-04
RC-6 CAM CLOSER	268385-05

DECAL SHEET PART NUMBERS

MODEL	ORDER P/N
RC-2 HYD CLOSER	268386-01
RC-3 HYD CLOSER	268386-02
RC-4 HYD CLOSER	268386-03
RC-5 HYD CLOSER	268386-04
RC-6 HYD CLOSER	268386-05

DECAL SHEET PART NUMBERS

OPTIONS

RCT LIGHT INSTALLATION

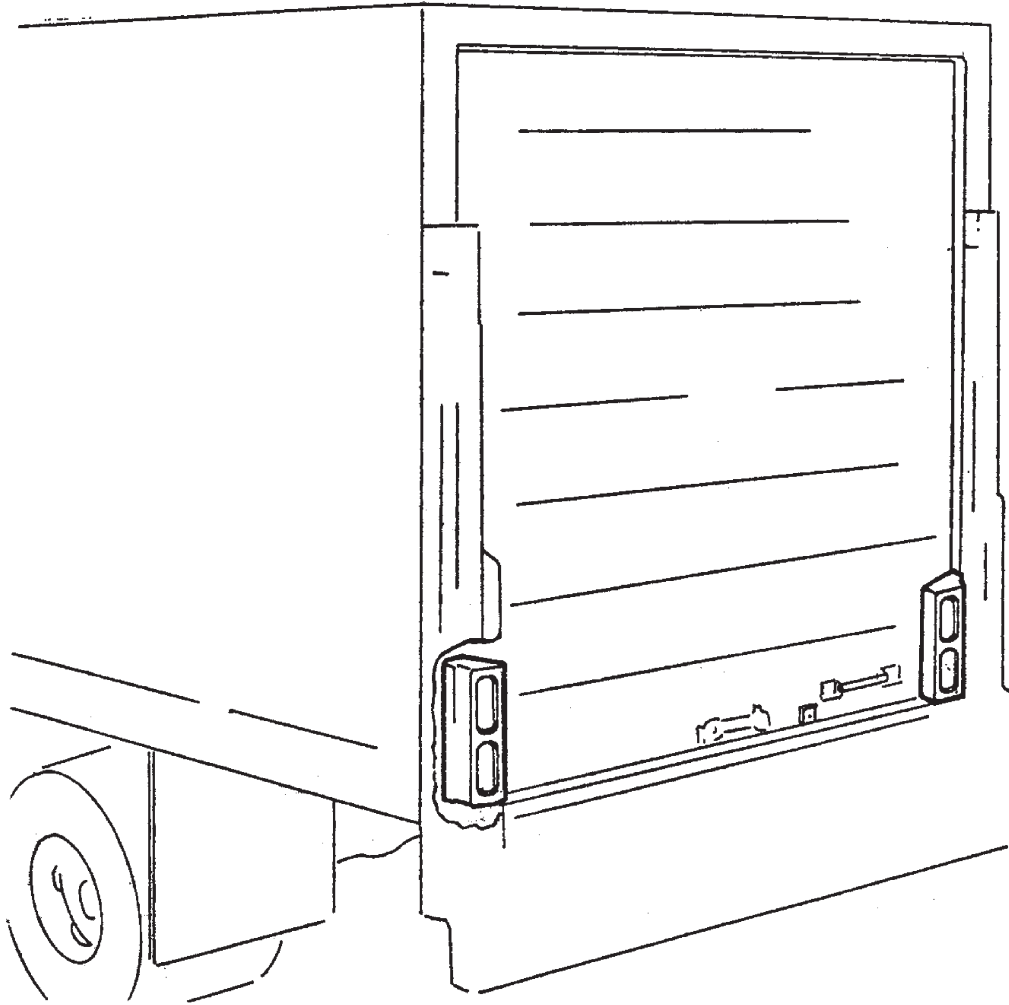

ALL RCT UNITS INCLUDE BACK LIGHTS

RCT LIGHT INSTALLATION - Continued

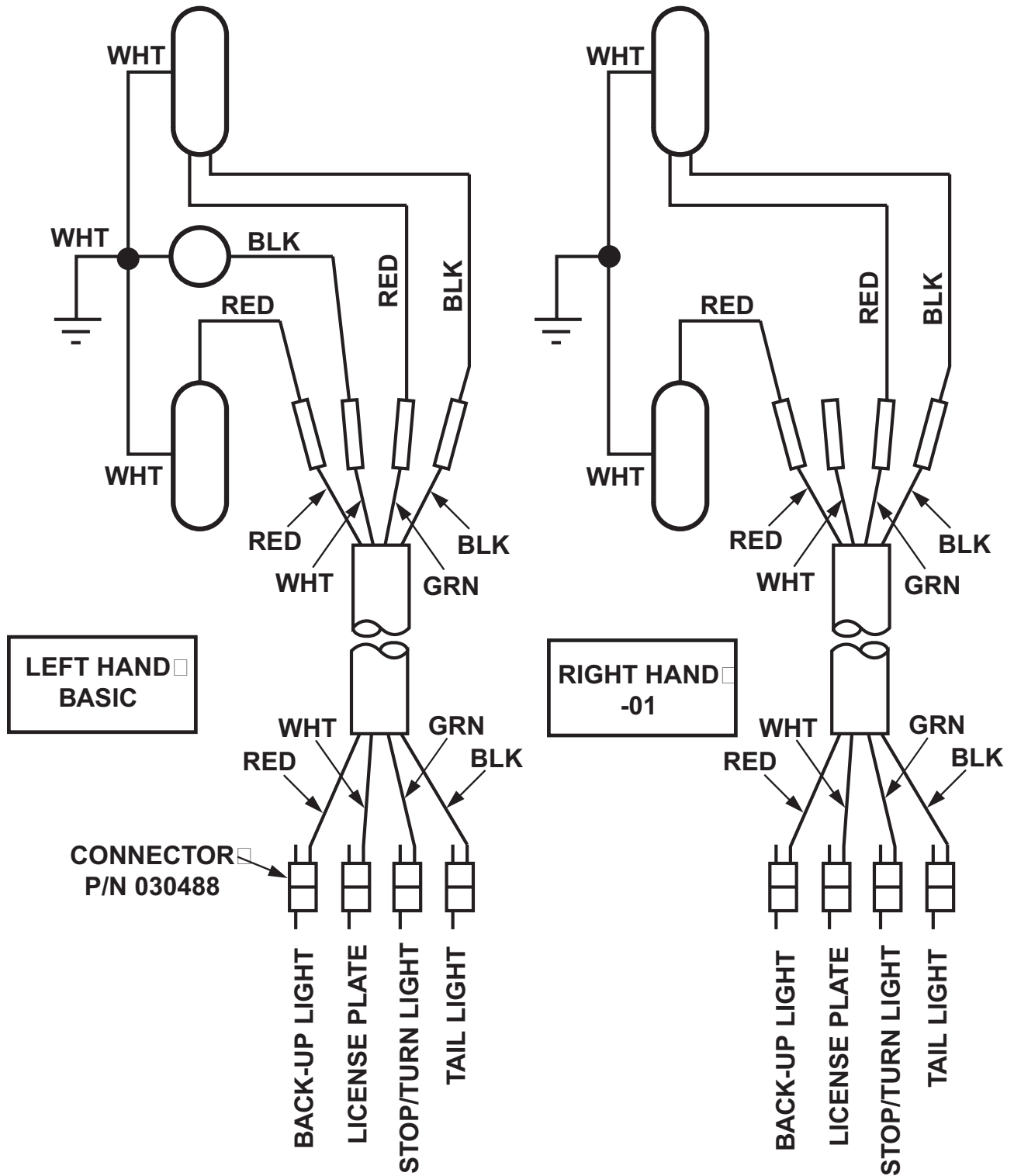

OPTIONS

HAND PUMP OPTION FOR CAM CLOSER

The procedure for lifting the platform using the hand pump is as follows:

1. Check if the relief valve is closed by using the handle to turn it clockwise until complete stop.
2. Close the flow control valve by turning the knob clockwise until it is fully closed.
3. Locate the handle in the hand pump and operate with an up and down motion.

To lower the platform, open the hand pump relief valve slowly to be able to control the down speed with this valve.

NOTE:

When going back to normal operation,

- a. Be sure to have the hand pump closed.
- b. Open and adjust the flow control valve.

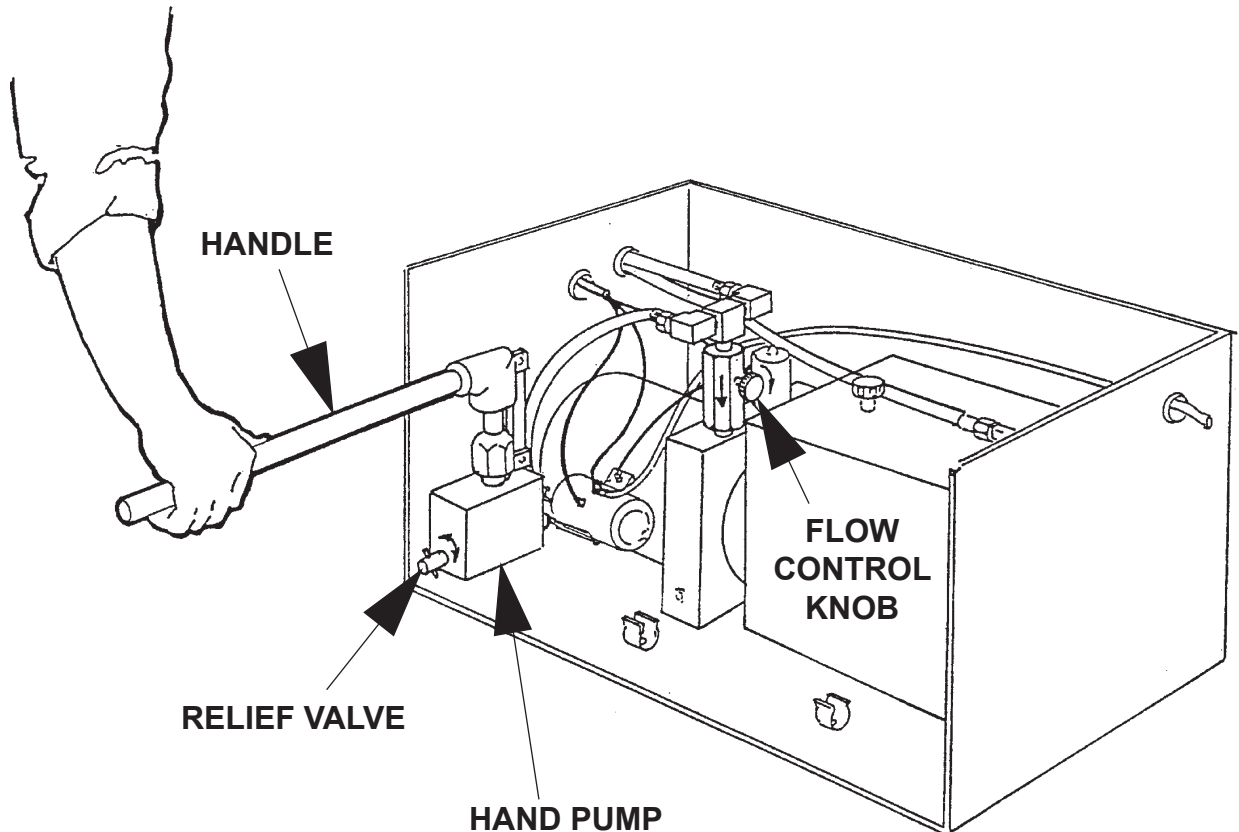

OPTIONS

RECOMMENDED LIFTGATE POWER CONFIGURATION

NOTE: Make sure the Liftgate power unit, and all batteries on the vehicle for the power unit, are connected correctly to a common chassis ground.

1. Liftgate and additional battery box are typically installed on trailers as shown in **FIG. 34-1** and on trucks as shown in **FIG. 34-2**. See the following page for battery and cable connections.

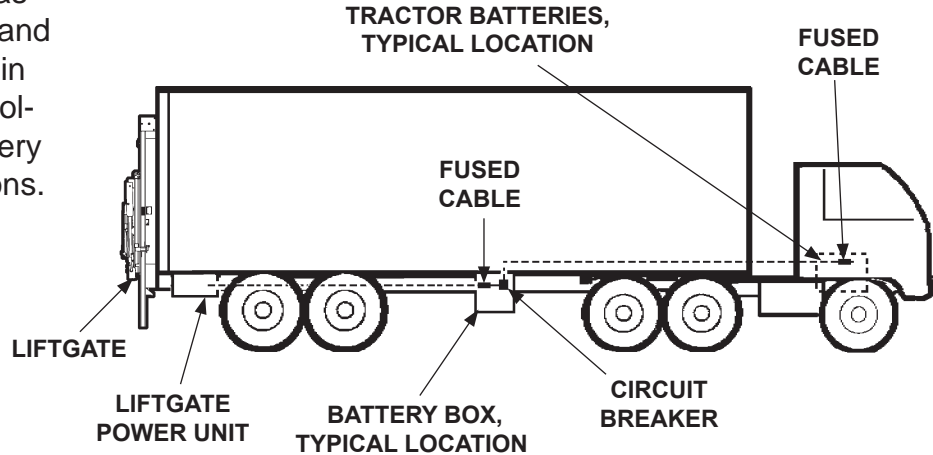

**RECOMMENDED BATTERY BOX
INSTALLATION ON TRAILER
FIG. 34-1**

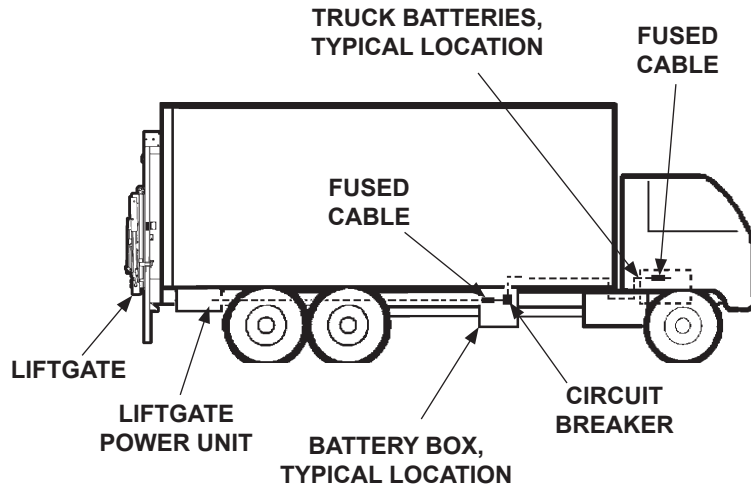

**RECOMMENDED BATTERY BOX
INSTALLATION ON TRUCK
FIG. 34-2**

RECOMMENDED LIFTGATE POWER CONFIGURATION - Continued

NOTE: Always connect fused end of power cable to battery positive (+) terminal.

2. Recommended battery box setup for **12 volt batteries** is shown in **FIG. 35-1**.

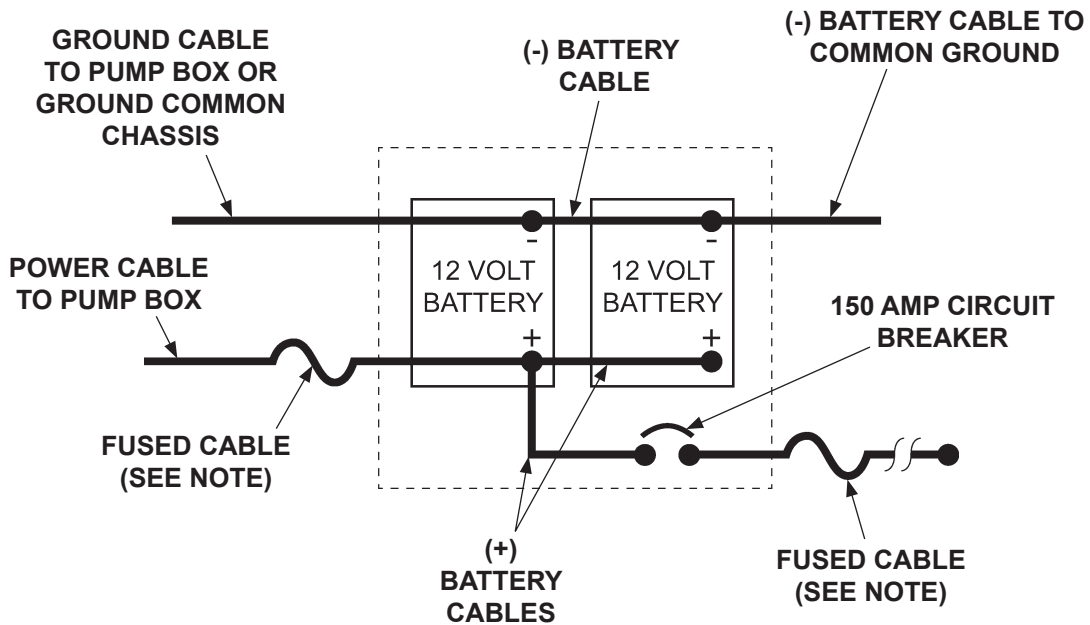

**12 VOLT BATTERY CONNECTIONS
FIG. 35-1**

OPTIONS

FIXED RAMP INSTALLATION, 6"

Lower the platform to level ground. Line up top edge of ramp with the front edge of the platform.

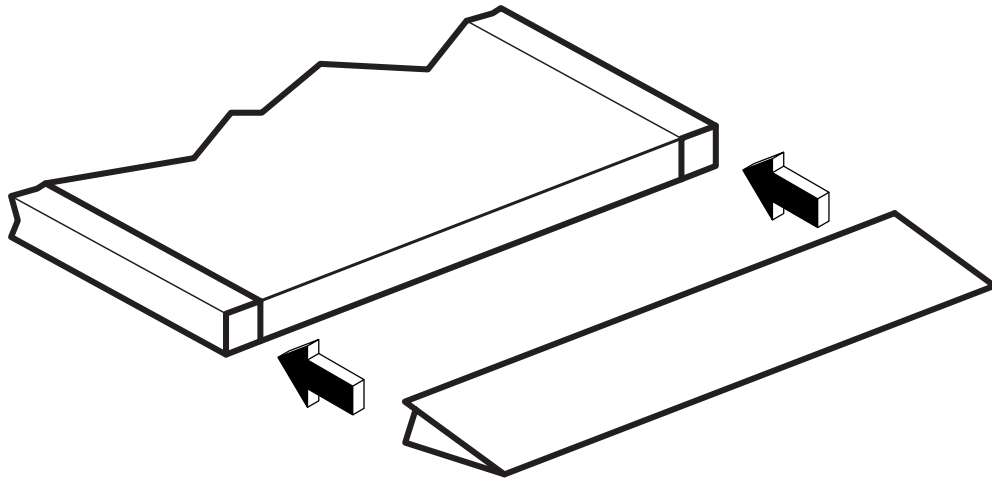

Weld 1/8" beads two inches long about every 6 or 8 inches along the entire length of the platform. Repeat procedure for the underside of the platform.

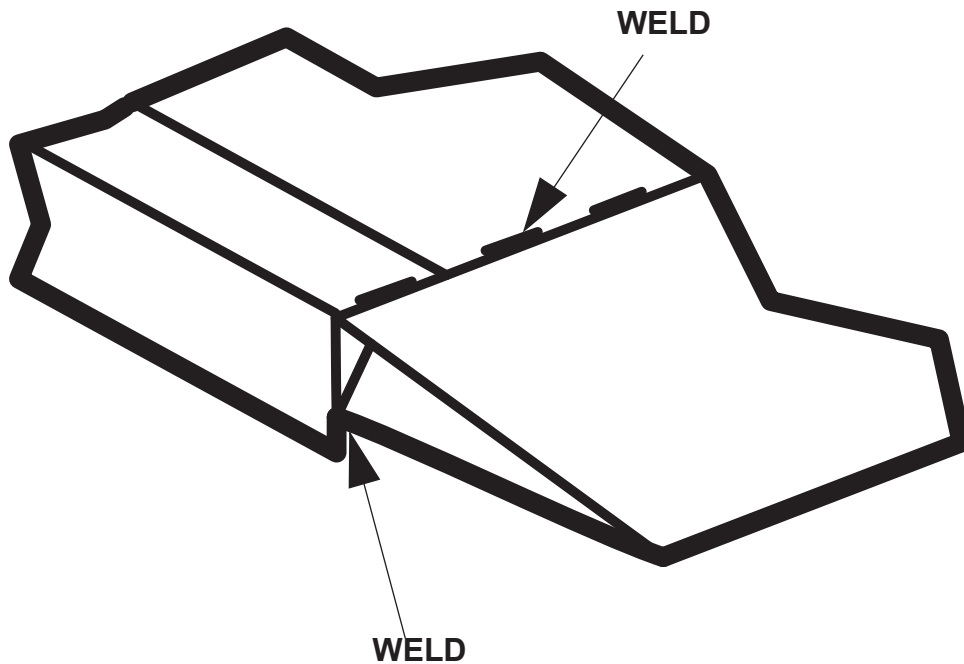

FIXED RAMP INSTALLATION, 12"

Lower the platform to level ground. Line up top edge of ramp with the front edge of the platform.

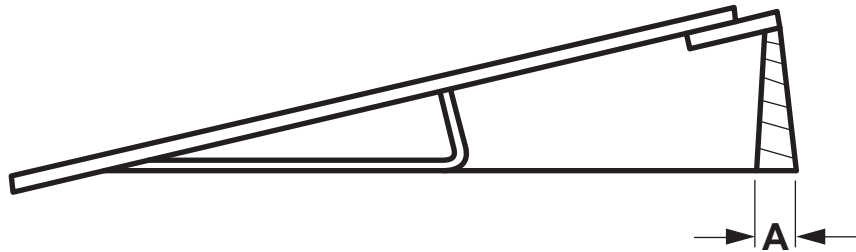
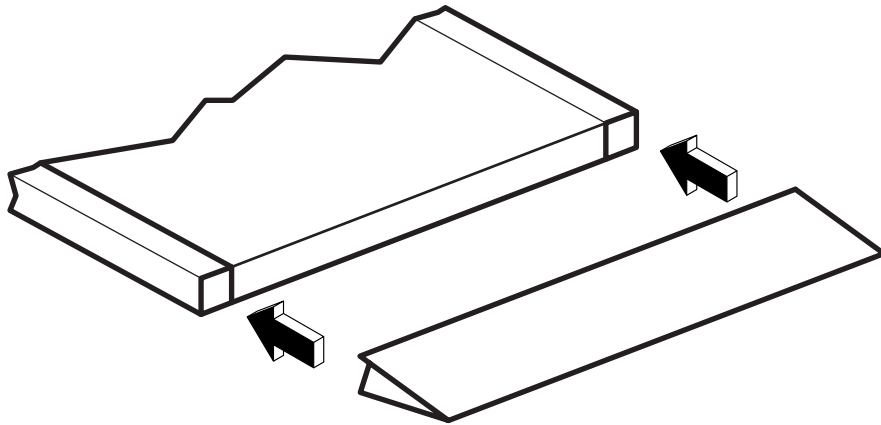

Cut rear edges of ramp as shown:
Single piece platform "A" = 3/8"
Folding platforms "A" = 1/2"

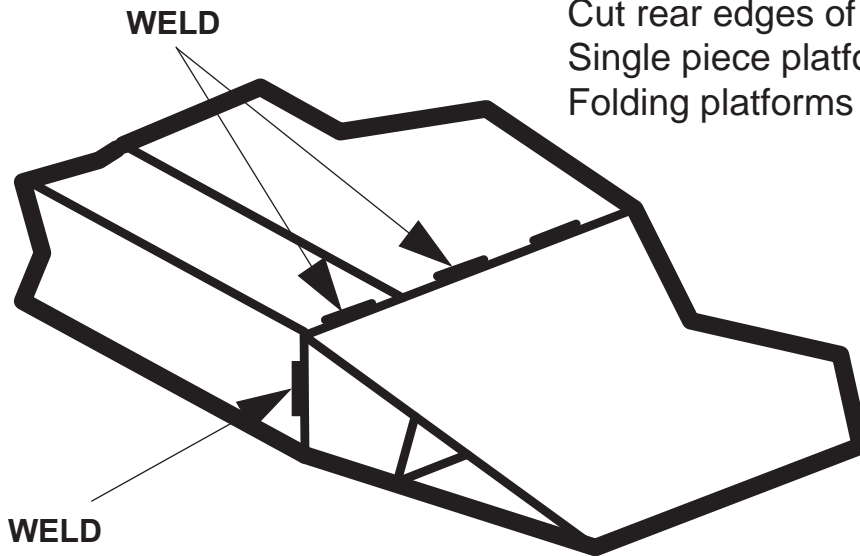

Weld 1/8" beads two inches long about every 6 or 8 inches along the entire length of the platform. Repeat procedure for the underside of the platform. Weld gussets full length.

CART STOP & DUAL CART STOP RAMP INSTALLATION

1. With the platform on the ground, center the Cart Stop Ramp against the butt end of the platform. Rest the Ramp Blocks on top of the platform and let the Ramp Tip touch the ground. Weld both sides into place.

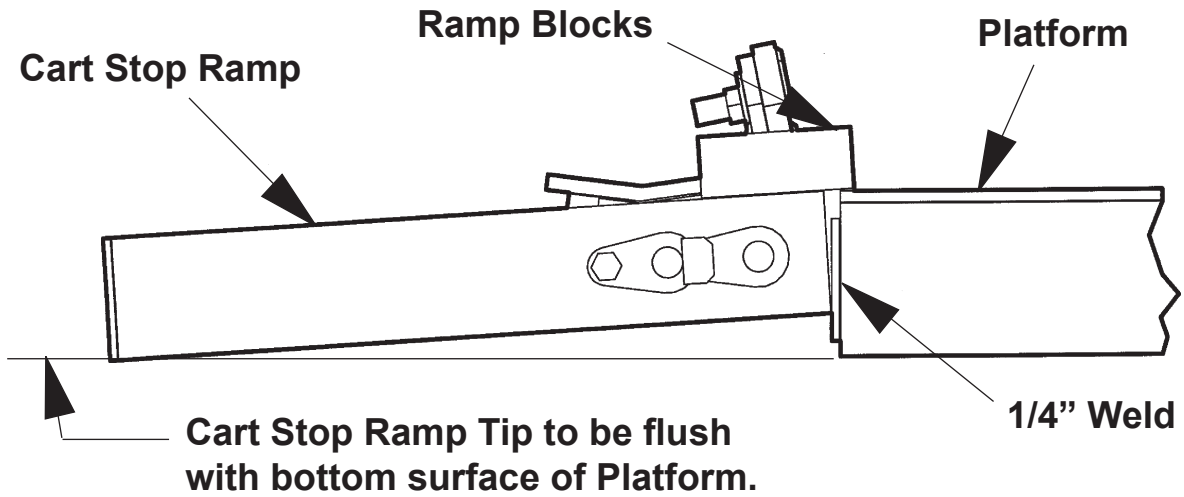

2. Pop open the Cart Stop Section of the ramp for ease of welding. Weld the top & bottom of the Ramp to the Platform with 2" long welds on approximately 12" centers. Grind all welds smooth and touch up with paint.

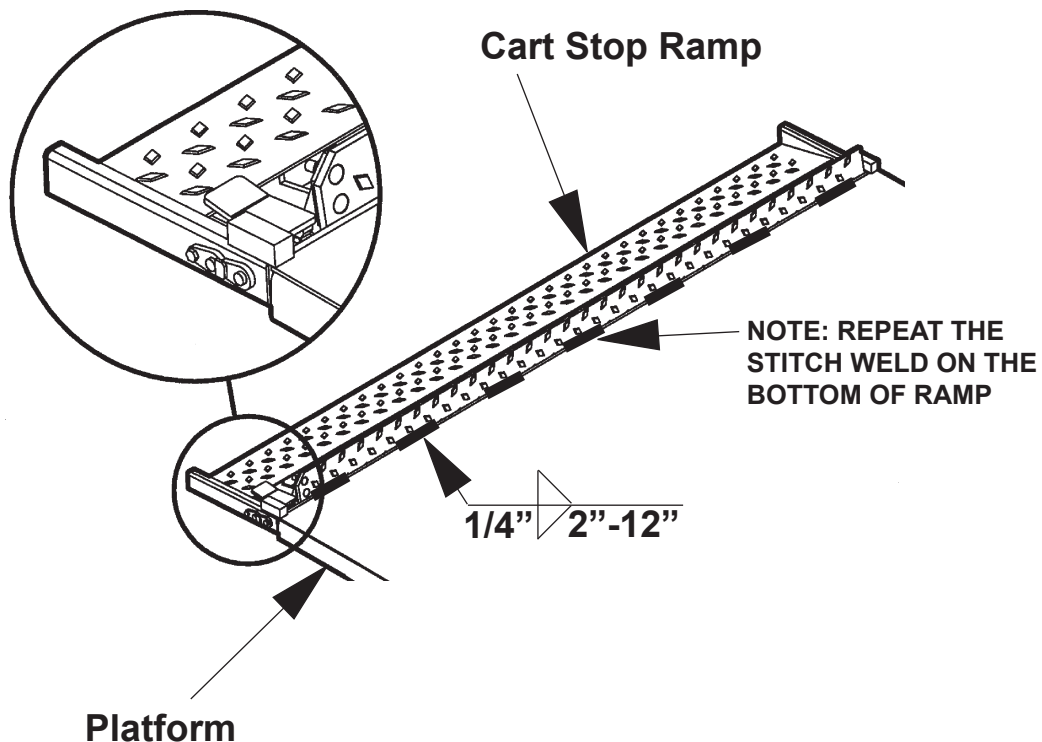

HINGED RAMP INSTALLATION (STEEL)

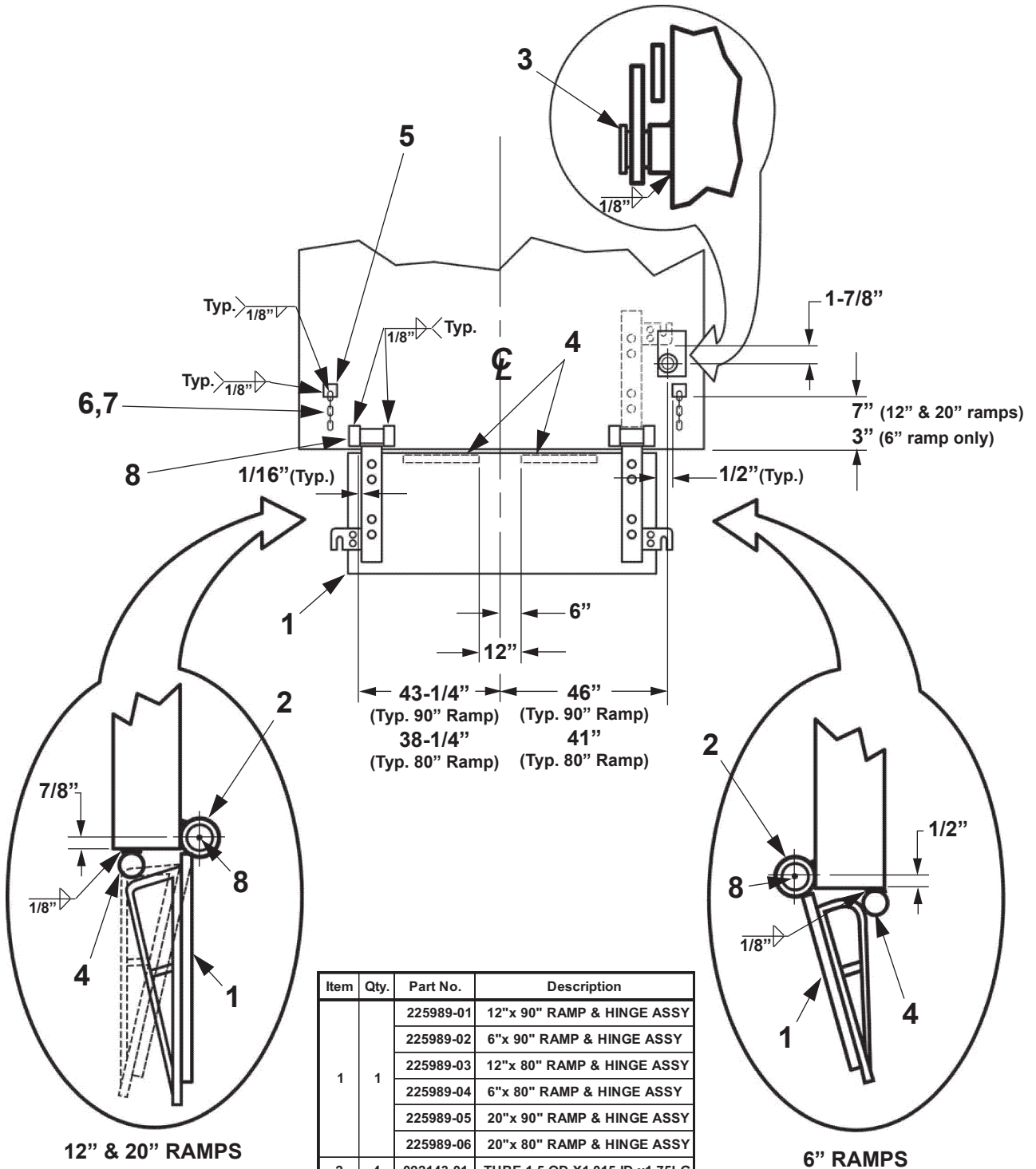

Item	Qty.	Part No.	Description
1	1	225989-01	12"x 90" RAMP & HINGE ASSY
		225989-02	6"x 90" RAMP & HINGE ASSY
		225989-03	12"x 80" RAMP & HINGE ASSY
		225989-04	6"x 80" RAMP & HINGE ASSY
		225989-05	20"x 90" RAMP & HINGE ASSY
		225989-06	20"x 80" RAMP & HINGE ASSY
2	4	092143-01	TUBE 1.5 OD X1.015 ID x1.75LG
3	1	221739-01	LATCH PLT. WMT. 1PC PTFM
		221739-02	LATCH PLT. WMT. 2PC PTFM
4	2	225998	BAR RD. 3/4" DIA. x 8" LG
5	2	201020	FLAT, 3/8 x 1 x 1-1/2" LG
6	2	202698-41	CHAIN 18" LG (12" & 20" RAMP ONLY)
7	2	202698-43	CHAIN 11" LG (6" RAMP ONLY)
8	2	224342	LUBE FITTING

MAXON 11921 Slauson Ave. Santa Fe Springs, CA. 90670 (800) 227-4116 FAX (888) 771-7713

HINGED RAMP INSTALLATION (ALUMINUM)

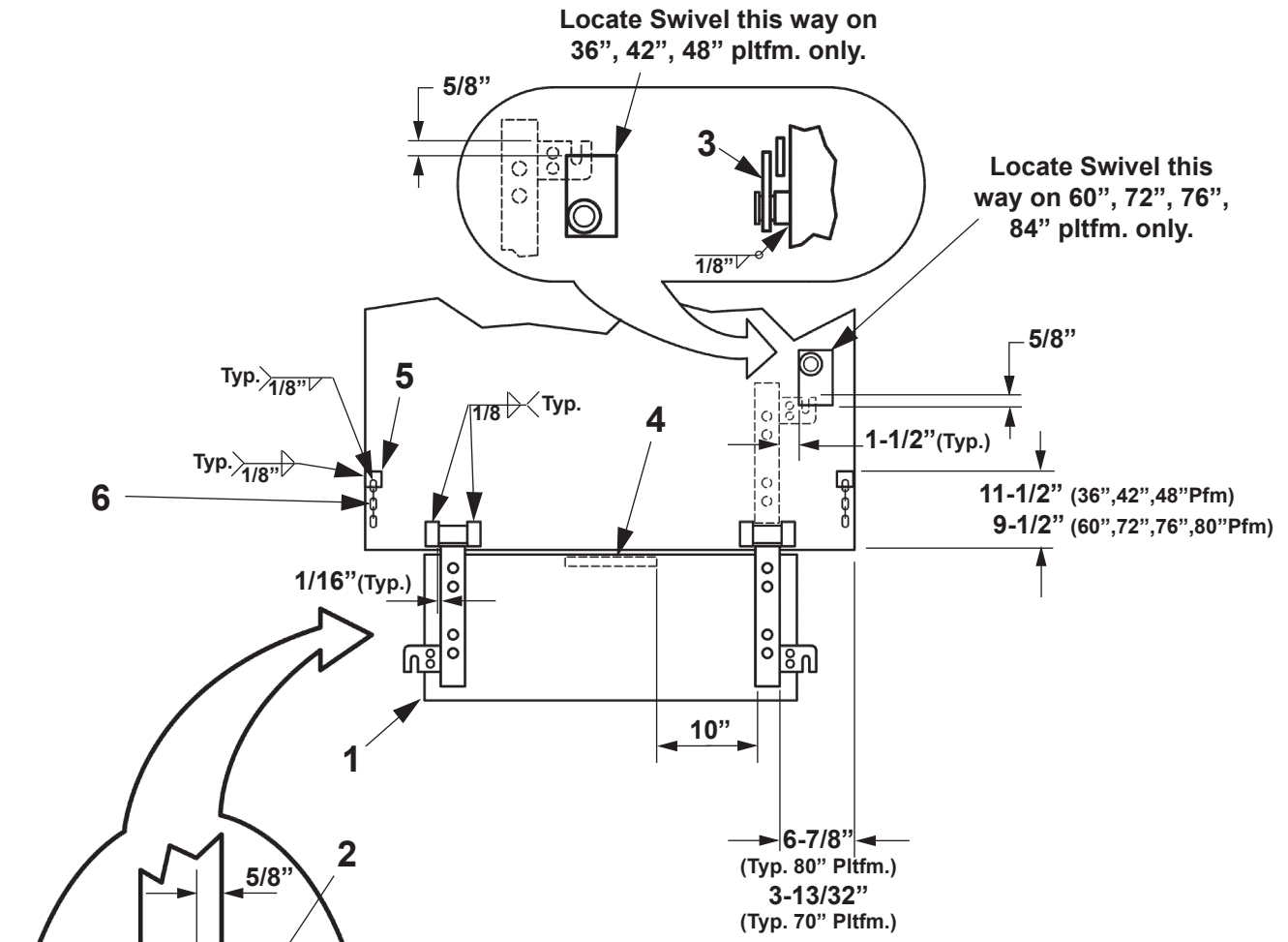

Item	Qty.	Part No.	Description
1	1	221543	16"x 80" RAMP ASSY.
		221543-01	16"x 80" REINFORCED ALUM. RAMP ASSY.
		229569	20"x 80" ALUM. RAMP ASSY.
		-	<input type="checkbox"/> OR <input type="checkbox"/> UTURE UPDÆE
		221543-100	16"x 70" RAMP ASSY.
2	1	092143-01	TUBE 1.5 OD x1.015 ID x1.75LG.
3	1	221739-01	LATCH PLT. WMT. 1PC PTFM.
		221739-02	LATCH PLT. WMT. 2PC PTFM.
4	1	225985	PIPE 3/4" SCH. 80 x 60" LG.
5	2	201020	FLAT, 3/8 x 1 x 1-1/2" LG
6	2	202698-41	CHAIN 18" LG.