

M-90-03  
REV. F  
MAR. 2000

# **MAXON<sup>®</sup>**

## **MAINTENANCE MANUAL**

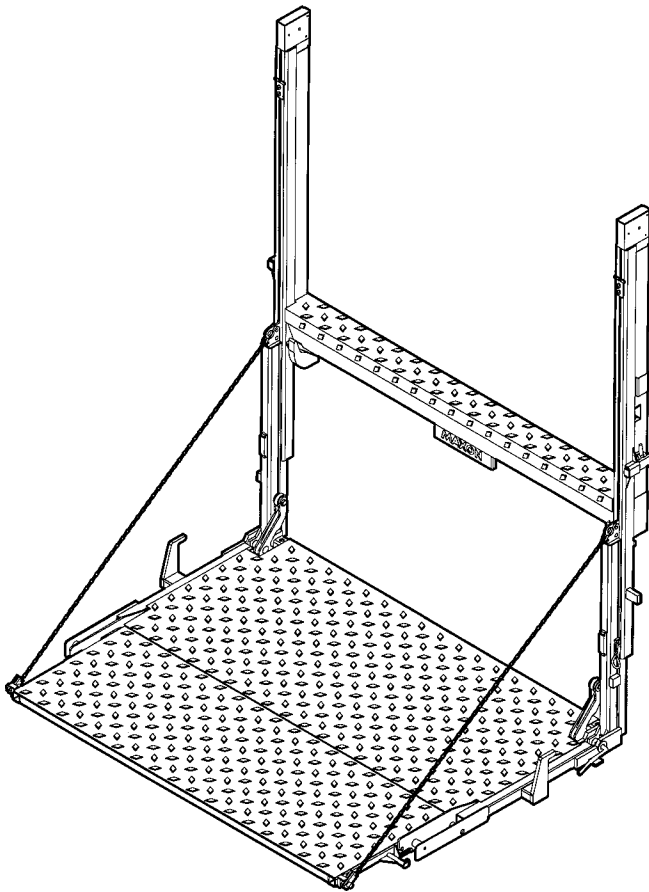

**RC-2B**

**RC-3B**

**RC-4B**

**RC-5B**

**RC-6B**

**RC-6K**

**MAXON<sup>®</sup>**

11921 Slauson Avenue.  
Santa Fe Springs, CA. 90670  
(800) 227-4116

# MAXON<sup>®</sup>

## LIFT CORP.

11921 Slauson Ave.  
Santa Fe Springs, CA. 90670

### CUSTOMER SERVICE:

(562) 464-0099

(800) 227-4116

FAX: (888) 771-7713

### TECHNICAL SERVICE:

(800) 8-MAXTEK (862-9835)

**NOTE: Check with Customer Service Department for updated versions of Manuals on an annual basis.**

## WARRANTY POLICY & PROCEDURE

### NEW LIFTGATE WARRANTY

Term of Warranty: 2 Years from Date of In-Service

Type of Warranty: Full Parts and Labor

MAXON agrees to replace any components which are found to be defective during the first 2 years of service, and will reimburse for labor based on MAXON's Liftgate Warranty Flat Rate Labor Schedule. (Call MAXON Customer Service for a copy).

All claims for warranty must be received within 30 Days of the repair date, and include the following information:

1. Liftgate Model Number
2. Liftgate Serial Number
3. Description of Problem
4. Corrective Action Taken, and Date of Repair.
5. Parts used for Repair, Including MAXON Part Number(s).
6. MAXON R.G.A. # and/or Authorization # if applicable (see below).
7. Person contacted at MAXON if applicable.

### PURCHASE PART WARRANTY

Term of Warranty: 1 Year from Date of Purchase Type of Warranty: Part Replacement and Replacement Labor.

MAXON will guarantee all returned genuine replacement parts upon receipt, and inspection of parts and invoice. All Warranty repairs must be performed by an authorized MAXON warranty station.

For major repairs, MAXON's Warranty Department must be notified, and an "Authorization Number" received. Major repairs would generally be considered repairs made to the structural assembly of the liftgate and/or repairs not outlined in the MAXON Liftgate Warranty Flat Rate Schedule.

Major components (i.e. hydraulic pumps, cylinders, valves, or failed structural parts) must be returned, freight pre-paid, prior to the claim being processed. To ensure timely processing of these warranty claims, an R.G.A. (Returned Goods Authorization) number must be obtained from MAXON's Warranty Department prior to the return of any defective part. Defective Parts must be returned within 60 days of the claim date for consideration to:

**Warranty Department, MAXON Lift Corp.  
5920 Alameda St., Huntington Park, CA. 90255**

MAXON's warranty policy does not include the reimbursement for travel time; towing; vehicle rental; service calls; fabrication of parts which are available from MAXON; oil; defects due to misuse or abuse; loss of income due to downtime.

MAXON's Flat Rate Labor Schedule times takes into consideration time required for diagnosis of problem.

Warranty and Technical Information is available by calling MAXON's Customer Service Department.

# Table of Contents

WARNING .....	PAGE 5
TROUBLE SHOOTING, CAM CLOSER .....	PAGE 6
<b>GENERAL MAINTENANCE .....</b>	<b>PAGE 8</b>
REPLACE CYLINDER SEALS .....	PAGE 9
CLEAN VALVE .....	PAGE 9
PUMP PRESSURE ADJUST SETTING .....	PAGE 10
RELEASING EMERGENCY BRAKE .....	PAGE 11
PUMP-SHAFT, COUPLING AND FILTER .....	PAGE 12
CHECK SOLENOID SWITCH .....	PAGE 12
FUSED POWER CABLE .....	PAGE 13
WIRING TO PUMP MOTOR .....	PAGE 14
ELECTRICAL SCHEMATIC (CAM TYPE) .....	PAGE 15
PUMP WIRING HYDRAULIC CLOSER .....	PAGE 16
WIRE ROPE SCHEMATIC .....	PAGE 17
WIRE ROPE MAINTENANCE .....	PAGE 18
WIRE ROPE ADJUSTMENT .....	PAGE 19
CAM FOLLOWER ADJUSTMENT .....	PAGE 21
3 MONTH MAINTENANCE SCHEDULE .....	PAGE 22
<b>PARTS REPLACEMENT .....</b>	<b>PAGE 23</b>
WIRE ROPE REMOVAL .....	PAGE 24
WIRE ROPE REPLACEMENT .....	PAGE 29
ADJUSTING NEW WIRE ROPES .....	PAGE 35
CYLINDER REPLACEMENT .....	PAGE 37

Continued on next page

## TABLE OF CONTENTS (Cont'd.)

<b>PARTS BREAKDOWN DRAWINGS .....</b>	<b>PAGE 39</b>
PARTS DRAWINGS (PAGE 1) .....	PAGE 40
PARTS DRAWINGS (PAGE 2) .....	PAGE 42
PARTS DRAWINGS (PAGE 3) .....	PAGE 45
PARTS DRAWINGS (PAGE 4) .....	PAGE 46
EMERGENCY BRAKE DRAWING .....	PAGE 48
PUMP, CAM CLOSER.....	PAGE 50
PUMP, HYDRAULIC CLOSER .....	PAGE 52
FOLDING PLATFORM VARIATIONS .....	PAGE 54
FOLD OVER SECTION VARIATIONS .....	PAGE 55
ONE-PIECE PLATFORM VARIATIONS .....	PAGE 56
RC/RCT HYDRAULIC CLOSER COMPONENTS .....	PAGE 57

## WARNING

1. Read the **Maintenance Manual** and understand it thoroughly before any maintenance of this unit is done.
2. Read the **YELLOW** urgent warning decal on the side of the vehicle close to the unit before operating.
3. If decals are dirty, clean them. If decals are defaced or missing, replace them. **Free replacements** are available from the manufacturer. See information at the end of the Warnings
4. Be aware that the safety and location of other people or objects should be considered before operation of this unit. Stand to one side of platform while operating this unit. Do not stand in a position that would put you in the path of any moving vehicles around you.
5. Do not stand under, or have any foreign object under the Platform when lowering. **Be sure that the lowering of the Platform and/or Flipover will miss your feet!**
6. Keep fingers, hands, arms, legs, and feet clear of moving parts when operating this unit.
7. If during your maintenance procedure, it becomes necessary to ride the platform, keep your feet and any foreign objects clear of the rear edge of the platform. Otherwise your feet or the foreign objects could become trapped between the edge of the platform and the vehicle bed.
8. Inspect all Roll Pins monthly, to insure that they are not broken. Replace if broken.
9. Inspect all hydraulic hoses and fittings annually. Check for cracks and deterioration, and replace if necessary.
10. **Disconnect battery** when replacing parts or servicing.
11. Do not allow children to ride, play with, or operate this unit.
12. In the event of an emergency while operating the unit, release the toggle switch and the unit will stop immediately.
13. A properly installed Lift should operate smoothly and the only noise during the operation of this unit should be from the Pump Unit during the raising of the Platform. Any scraping, grating or audible indications of rough operation will need investigating. The cause will need resolving before any further deterioration of performance occurs.
14. Use only **Maxon Authorized Parts** for replacement. Replacement parts should be ordered from:

MAXON LIFT CORP. Parts Department  
11921 Slauson Ave., Santa Fe Springs, Ca. 90670  
Phone: (800) 227-4116

# TROUBLE SHOOTING, CAM CLOSER

FAULT	CAUSE	REMEDY
PLATFORM WILL NOT RISE OR REACH FLOOR OF VEHICLE	1. BATTERY FLAT	RE-CHARGE BATTERY
	2. (TRACTOR/TRAILER VEHICLE ONLY) ELECTRICAL COUPLING TO TRACTOR NOT CONNECTED	CONNECT COUPLIN
	3. INSUFFICIENT OIL IN THE PUMP RESERVOIR	FILL RESERVOIR SEE DECAL ON PUMP.
	4. WIRE ROPE INCORRECTLY ADJUSTED	ADJUST WIRE ROPE.
PLATFORM WILL NOT LOWER	1. BATTERY FLAT (VOLTAGE AT SOLENOID LOW)	RE-CHARGE BATTERY
	2. (TRACTOR/TRAILER VEHICLES ONLY) ELECTRICAL COUPLING TO TRACTOR NOT CONNECTED	CONNECT COUPLING
	3. EMERGENCY BRAKE LOCK-UP	RELEASE EMERGENCY BRAKE
PLATFORM DOES NOT RISE SMOOTHLY	1. TOO MUCH PUMP PRESSURE	CHECK PRESSURE
	2. INSUFFICIENT OIL IN THE PUMP RESERVOIR	FILL RESERVOIR
	3. AIR LOCK IN HYDRAULIC SYSTEM	OPERATE RAISE CONTROL ON THE SWITCH A FEW SECONDS AT TOP OF PLATFORM STROKE. REPEAT TWO MORE TIMES, PAUSING BETWEEN OPERATIONS FOR ONE MINUTE WITH PLATFORM ON GROUND.
	4. UNDUE MECHANICAL WEAR OR LACK OF LUBRICATION OF LIFT	LUBRICATE OR REPLACE WORN PARTS
PLATFORM CREEPS DOWN UNDER NO LOAD CONDITION	1. HYDRAULIC LEAK	OPERATE RAISE CONTROL ON THE SWITCH AT TOP OF PLATFORM STROKE FOR A FEW SECONDS.
	2. CYLINDER SEAL FAILING	REPLACE CYLINDER SEALS.
	3. DIRT UNDER VALVE IN HYDRAULIC PUMP	CLEAN THE VALVE
PLATFORM WILL ONLY DESCEND SLOWLY	1. FLOW CONTROL VALVE ADJUSTMENT	ADJUST FLOW CONTROL VALVE
	2. INSUFFICIENT MAINTENANCE AND LUBRICATION	CARRY OUT MAINTENANCE AND LUBRICATION PROCEDURE
	3. UNDUE WEAR OF MECHANICAL COMPONENTS	CHECK OUT MAINTENANCE AND LUBRICATION PROCEDURE
	4. DIRT IN THE VALVE	CLEAN THE VALVE
CAN NOT ENGAGE THE P/F RETENTION CHAIN	1. P/F DOES NOT CLOSE ENOUGH TO ALLOW RETENTION CHAIN TO BE ENGAGED.	ADJUST CAM FOLLOWER

**MAXON**<sup>®</sup>

11921 Slauson Ave. Santa Fe Springs, CA. 90670 (800) 227-4116 FAX (888) 771-7713

# TROUBLE SHOOTING, CAM CLOSER (Cont'd.)

FAULT	CAUSE	REMEDY
PLATFORM WILL ONLY DESCEND SLOWLY (CONT'D)	4. INCORRECT OIL IN SYSTEM. * SEE FOOTNOTE BELOW	OIL SHOULD BE ISO Grade 32 Hydraulic or ATF Transmission Oil. We would prefer ISO Grade 32 Oil
	5. RESTRICTED HYDRAULIC LINE	CHECK HOSE FOR WXTERNAL DAMAGE OR "PINCHING"
PLATFORM TILTED	1. INCORRECT WIRE ROPE ADJUSTMENT	ADJUST WIRE ROPE.
	2. WIRE ROPE SUPPORTING LOW SIDE OF PLATFORM DISLODGED FROM IT'S NORMAL LAY	CHECK THAT WIRE ROPE IS CORRECTLY SEATED IN THE GROOVES OF THE SHEAVES OVER WHICH THE WIRE ROPE PASSES
	3. PASSAGE OF WIRE ROPES, RUNNERS OR PLATFORM OBSTRUCTED	CHECK FREEDOM OF ALL MOVING PARTS ASSOCIATED WITH WIRE ROPE SYSTEM
UNIT WILL NOT LIFT RATED LOAD	1. RELIEF VALVE SETTING TOO LOW	ADJUST RELIEF VALVE SETTING.
	2. HYDRAULIC PUMP WORN	CHANGE WORN PARTS OR COMPLETE PUMPM. SEE PUMP BREAKDOWN ILLUSTRATIONS
PLATFORM NOT LEVEL	1. 2 PC PLATFORM CHAINS TOO LONG	SHORTEN CHAINS
PUMP WILL NOT OPERATE	1. BATTERY FLAT	RE-CHARGE BATTERY
	2. (TRACTOR/TRAILER VEHICLE ONLY) ELECTRICAL COUPLING TO TRAILER NOT CONNECTED	CONNECT COUPLING
	3. ELECTRICAL WIRING TO PUMP BROKEN OR CORRODED	CHECK WIRING TO PUMP
	4. REMOTE CONTROL SWITCH WIRING BROKEN	CHECK WIRING TO REMOTE CONTROL SWITCHES.
	5. SOLENOID SWITCH ON PUMP FAULTY	CHECK SOLENOID SWITCH.

\* **COLD WEATHER OPERATION**

**OIL SPECIFICATIONS:**

Grade ISO-(32)  
Gravity, API - 29.5 Degrees  
Pour Point, F- (-54 Degrees)

**VISCOSITY:**

@ 40 Degrees C - 31.2 cSt  
@100 Degrees C - 6.2 cSt  
VISCOSITY INDEX - 154 VI  
Flash Point, F - 325 Degrees

**MAXON**<sup>®</sup>

11921 Slauson Ave. Santa Fe Springs, CA. 90670 (800) 227-4116 FAX (888) 771-7713

# GENERAL MAINTENANCE



# REPLACE CYLINDER SEALS

To check for cylinder seal leakage the cover will need to be removed from the main frame assembly. The platform should be operated up and down several times. **NOTE:** Small amounts of “sepage” is normal, but if large a amount of oil is gushing from the Breather or Rod , it is considered a leak.

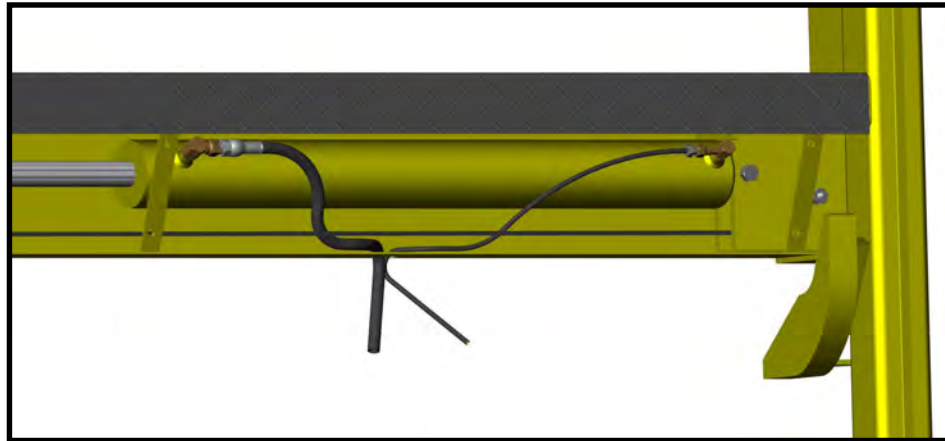

If there is a leak, the cylinder seals should be replaced. Seal kits are available from MAXON Industries Inc.

Pro Seal kit Part Number see Unit Parts Breakdown drawing for YOUR unit in this manual.

To replace the seals the cylinder will need to be removed from the main frame assembly and dismantled on a work bench. For removal of cylinder see Cylinder Replacement Page.

## CLEAN VALVE

Check valve could be slightly open. Slight adjustment in a CLOCKWISE direction may cure problem. If not, valve should be removed, cleaned and inspected.

CHECK FOR NICKS

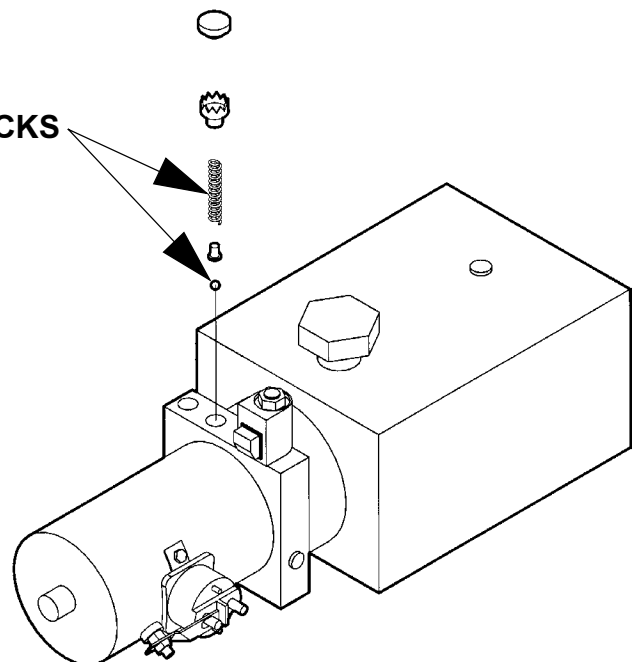

## PUMP PRESSURE ADJUST SETTING

Lower the Platform to the ground to relieve any pressure on the hoses. Remove the existing hose and swivel assembly from Port "B" (3/8 NPT). Install a 0-3000 PSI Gauge (Item 1), to port "B".

Remove the Valve Cap (Item 2), from the Pump Block (Item 3). Using the Raise/Lower Switch on the Curb side of the vehicle, raise the unit and check the gauge reading. Adjust the relief valve to a pressure setting of **2750 PSI**.

Activate the Raise/Lower Switch several times to verify that the pressure shown on the gauge will remain at the proper setting. (Ref. Fig. 1)

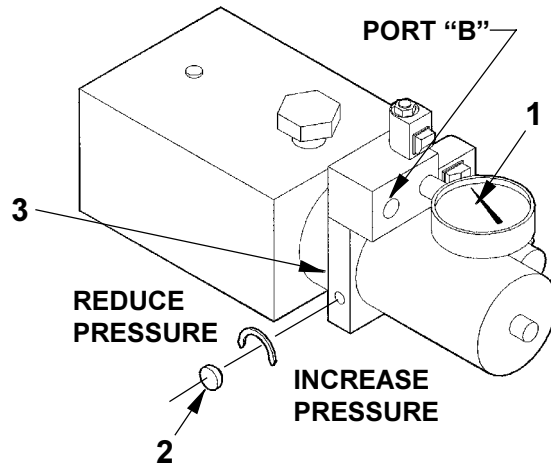

**FIGURE 1**

### WARNING

Setting the pressure higher than recommended could enable the lift to raise loads in excess of it's rated capacity.

If the unit does not maintain the pressure reading, it may be necessary to remove and inspect the relief valve components. (Ref. Fig. 2)

Check for nicks or cuts on the Spring (Item 4), and Ball (Item 5). Replace any damaged parts before reassembling the unit.

Upon reassembly, you will have to seat the Ball by inserting a 3/16" diameter rod through the spring and tapping the Ball against the seat with a hammer.

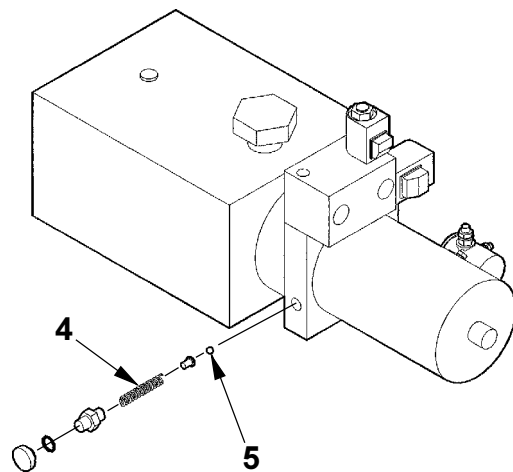

**FIGURE 2**

**MAXON**

11921 Slauson Ave. Santa Fe Springs, CA. 90670 (800) 227-4116 FAX (888) 771-7713

## RELEASING EMERGENCY BRAKE

IN THE EVENT THE RAILIFT WILL NOT LOWER, IT MAY BE NECESSARY TO RELEASE THE EMERGENCY BRAKE ASSEMBLY.

1. REMOVE THE UPPER SHEAVE COVERS ON THE SIDE WHICH IS NOT LOWERING.
2. REMOVE THE UP-STOP AT THE TOP OF COLUMN.
3. BEING CAREFUL NOT TO RAISE THE GATE MORE THAN 1-1/2", ACTIVATE THE RAISE SWITCH. THIS WILL RETRACT THE EMERGENCY BRAKE CAM AND ALLOW THE PLATFORM TO BE LOWERED. LOWER GATE APPROXIMATELY 12".
4. REPLACE UP-STOP TO ITS ORIGINAL POSITION. CYCLE RAILIFT SEVERAL TIMES TO INSURE IT OPERATES PROPERLY. REPLACE SHEAVE COVERS.

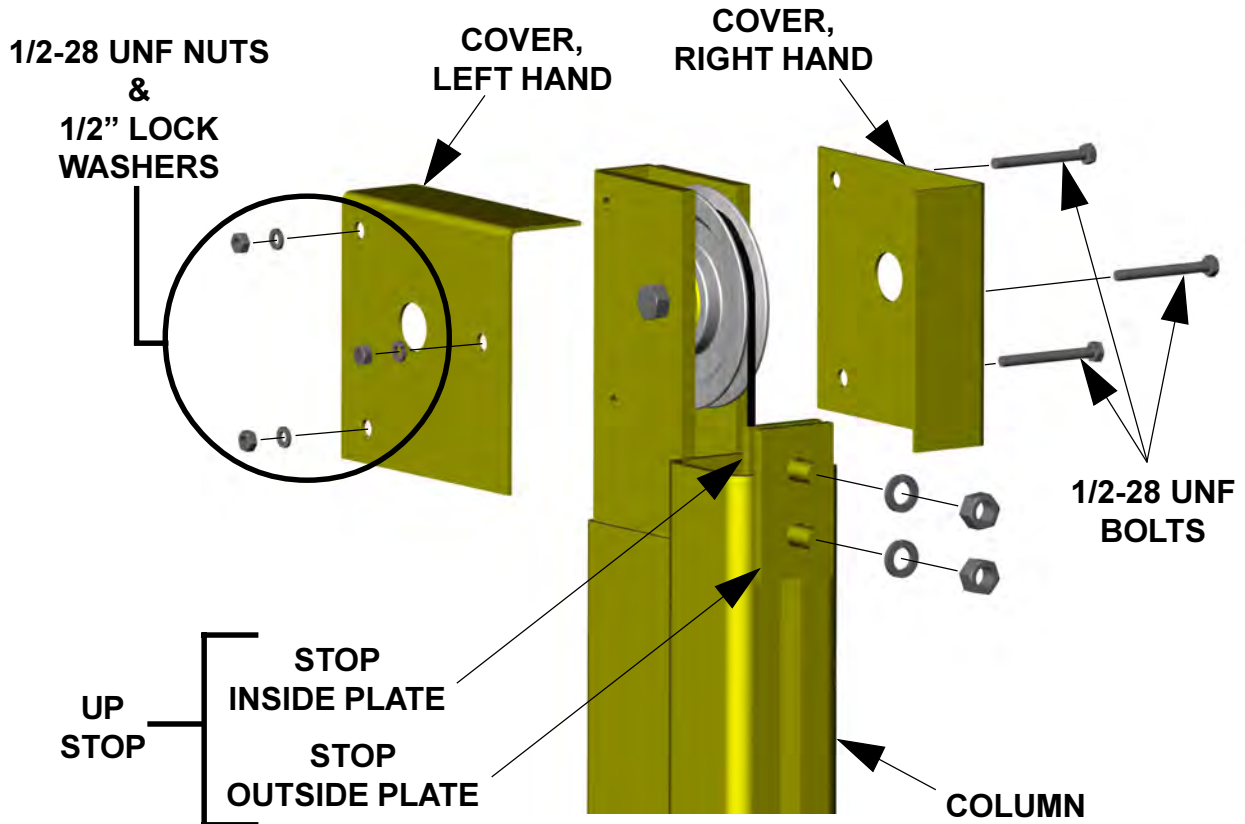

## PUMP-SHAFT, COUPLING AND FILTER

Drain and remove reservoir. Check filter. If Filter is clean, a worn pump is indicated. Change pump assembly. For replacement parts see PUMP BREAKDOWN DRAWING.

Inspect coupling for wear. When installing pump assembly, make sure coupling is installed to motor shaft and pump shaft is installed to coupling.

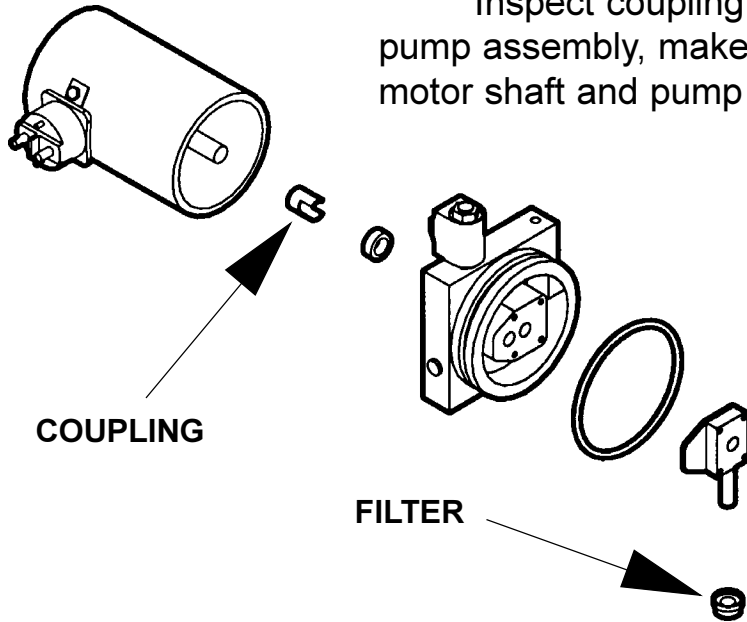

---

## CHECK SOLENOID SWITCH

Verify that power is being supplied to the Solenoid Terminal "A".  
Recharge the battery if less than 12 volts.

Touch a jumper wire to terminals "A" & "C". If motor runs, check Switch, Switch connections, and White wire. Correct the connections or replace the Switch.

Touch heavy jumper cables to terminals "A" & "B".

- If motor runs, replace the motor solenoid.
- If motor does not run, repair or replace the pump motor.

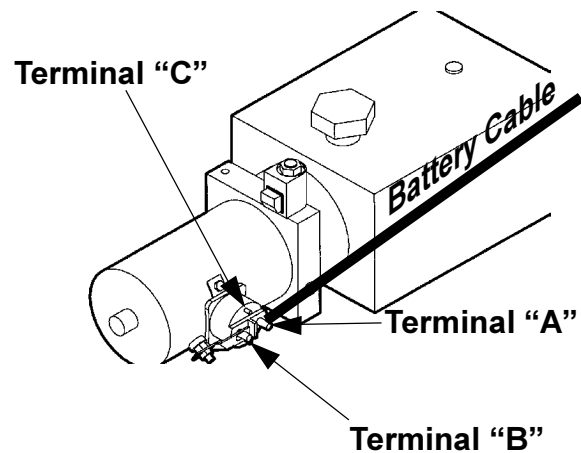

# FUSED POWER CABLE

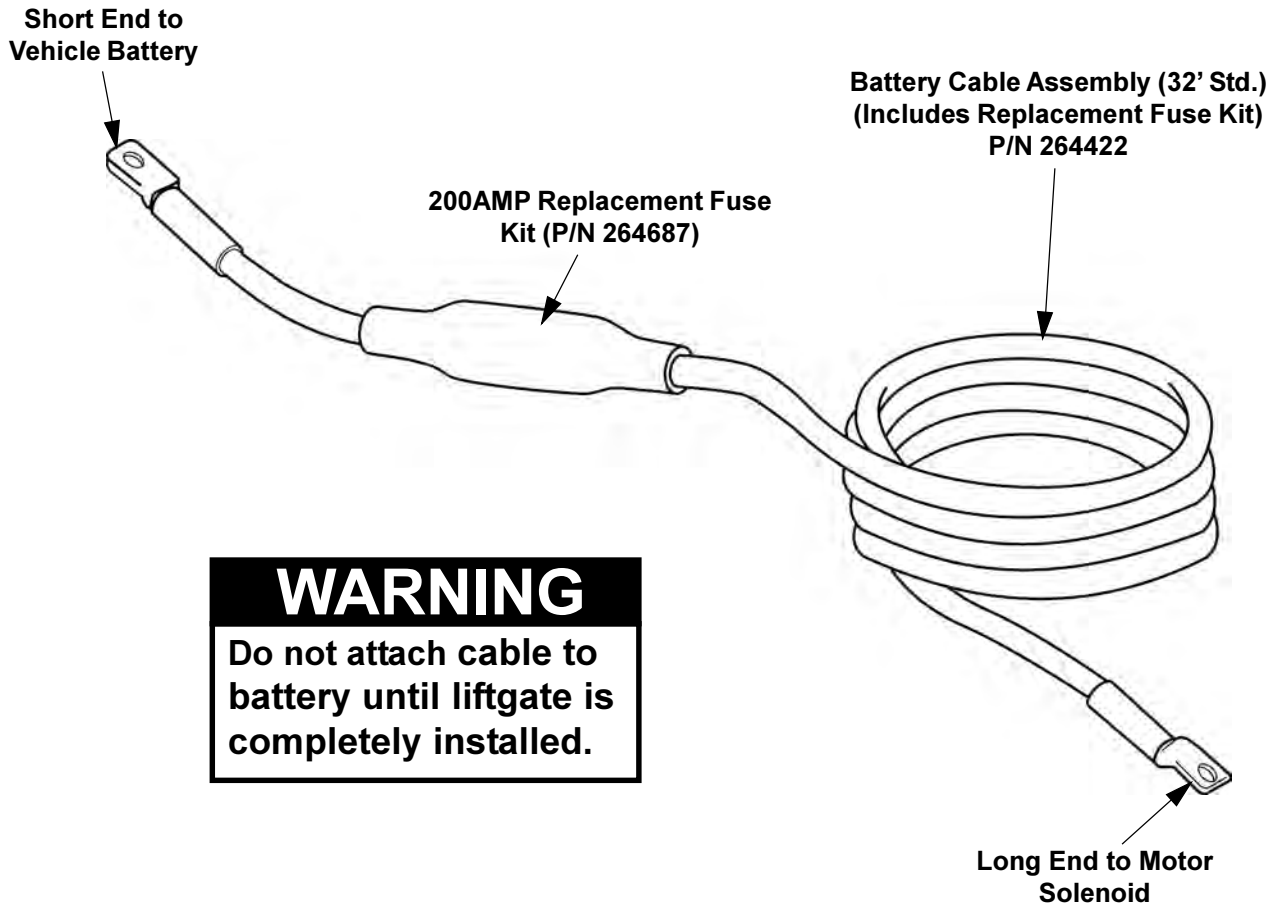

**WARNING**  
Do not attach cable to battery until liftgate is completely installed.

ADDITIONAL AVAILABLE BATTERY CABLE KITS		
	PART NUMBER	
40' CABLE ASSEMBLY	264848	<p><b>Cable Assembly</b></p>
10' EXTENSION CABLE ASSEMBLY	264849	<p><b>Extension Cable Assembly</b></p>

**MAXON**<sup>®</sup> 11921 Slauson Ave. Santa Fe Springs, CA. 90670 (800) 227-4116 FAX (888) 771-7713

# WIRING TO PUMP MOTOR

THE WIRING ON THE PUMP SOLENOID SWITCH THRU TO THE TRUCK SOLENOID (OR BATTERY) SHOULD BE CHECKED EVERY MONTH.

CABLE ENDS SHOULD BE CLEAN AND TIGHT. A LARGE AMOUNT OF GATE MALFUNCTION IS CAUSED BY LOOSE CABLE CONNECTIONS AND CORRODED CABLE CONNECTIONS.

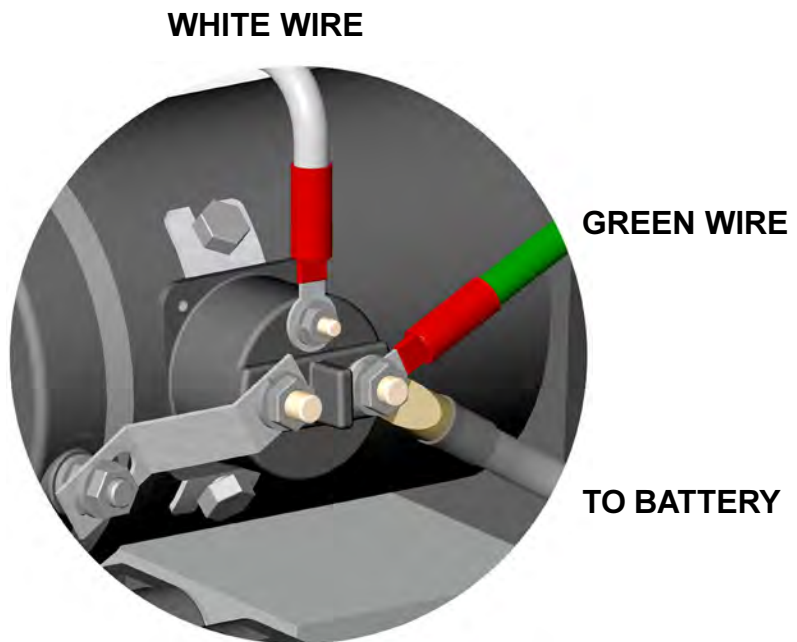
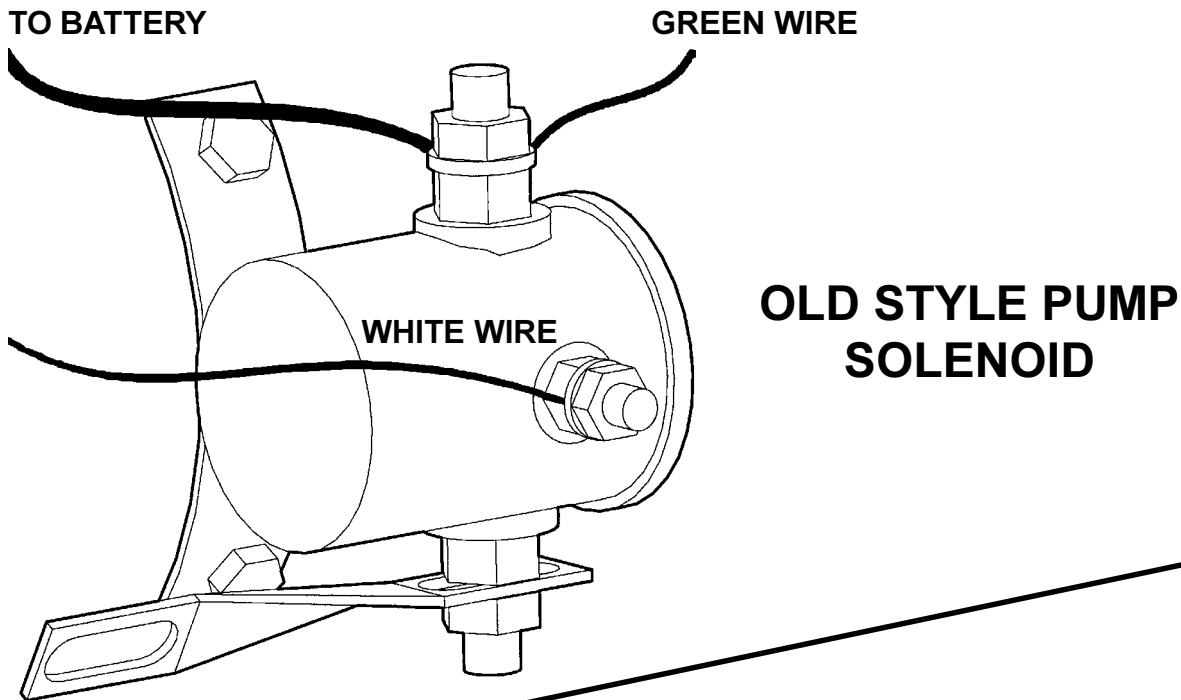

**MAXON**

11921 Slauson Ave. Santa Fe Springs, CA. 90670 (800) 227-4116 FAX (888) 771-7713

# ELECTRICAL SCHEMATIC (CAM TYPE)

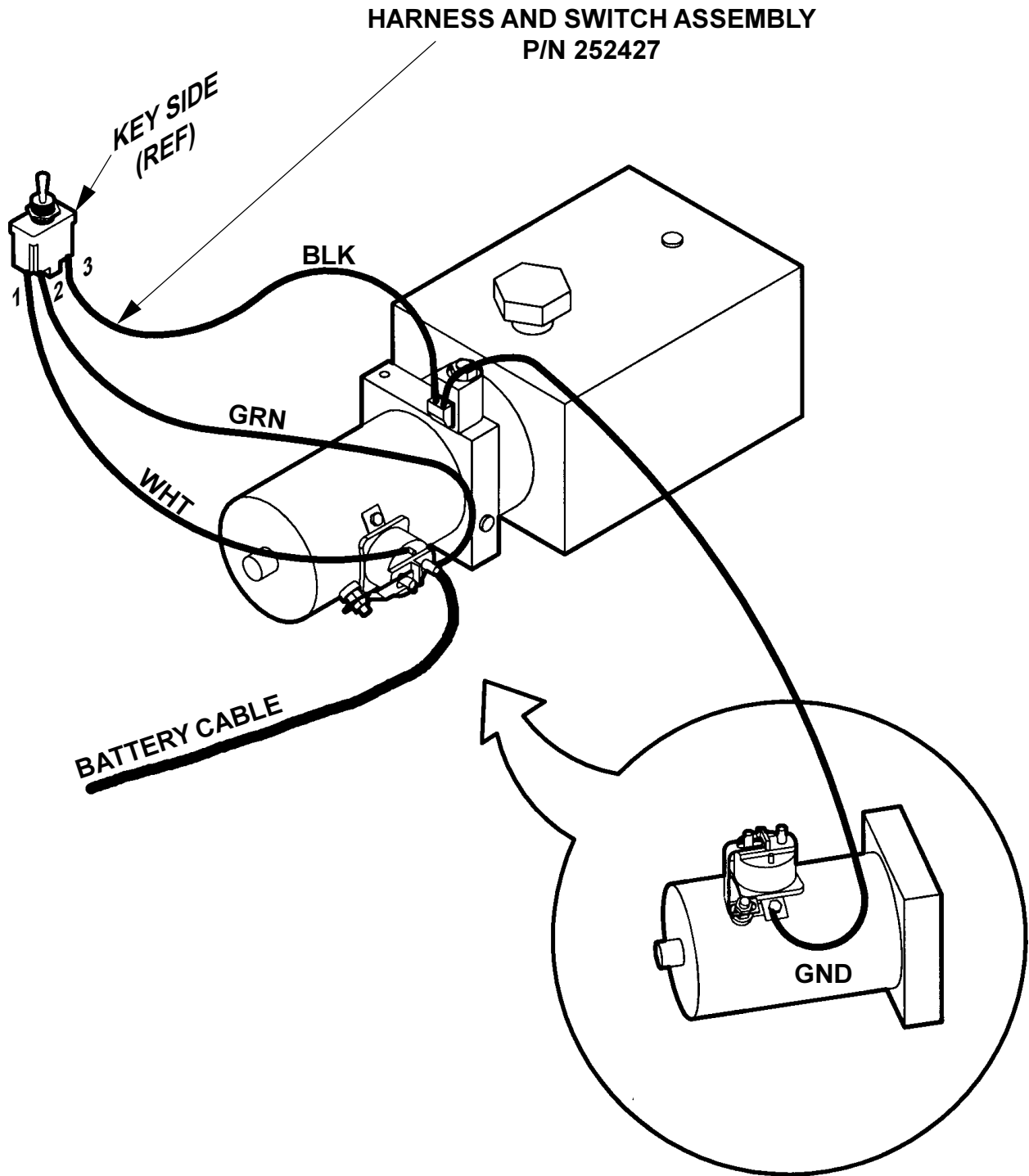

# PUMP WIRING HYDRAULIC CLOSER

**MAXON**® 11921 Slauson Ave. Santa Fe Springs, CA. 90670 (800) 227-4116 FAX (888) 771-7713

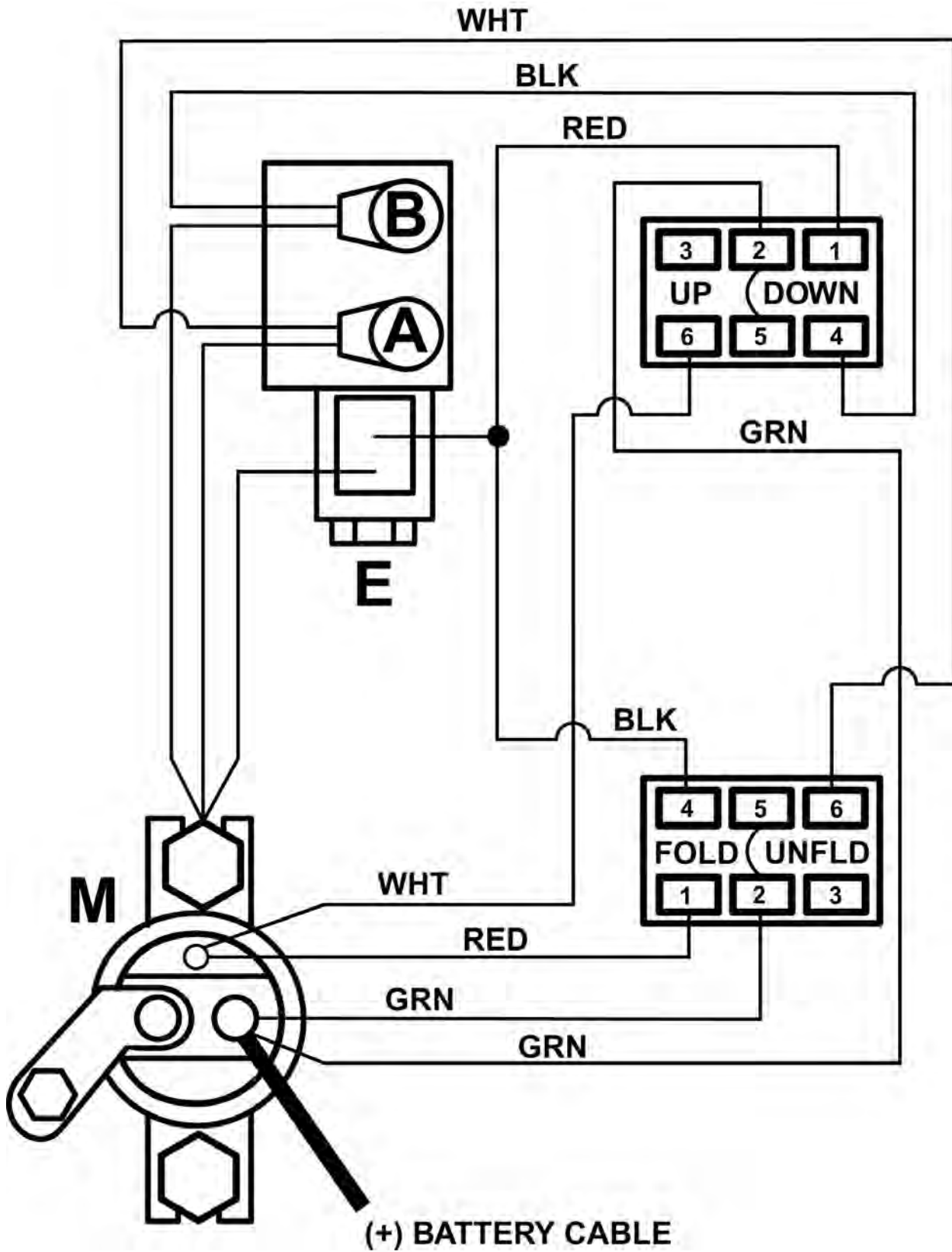



# WIRE ROPE SCHEMATIC

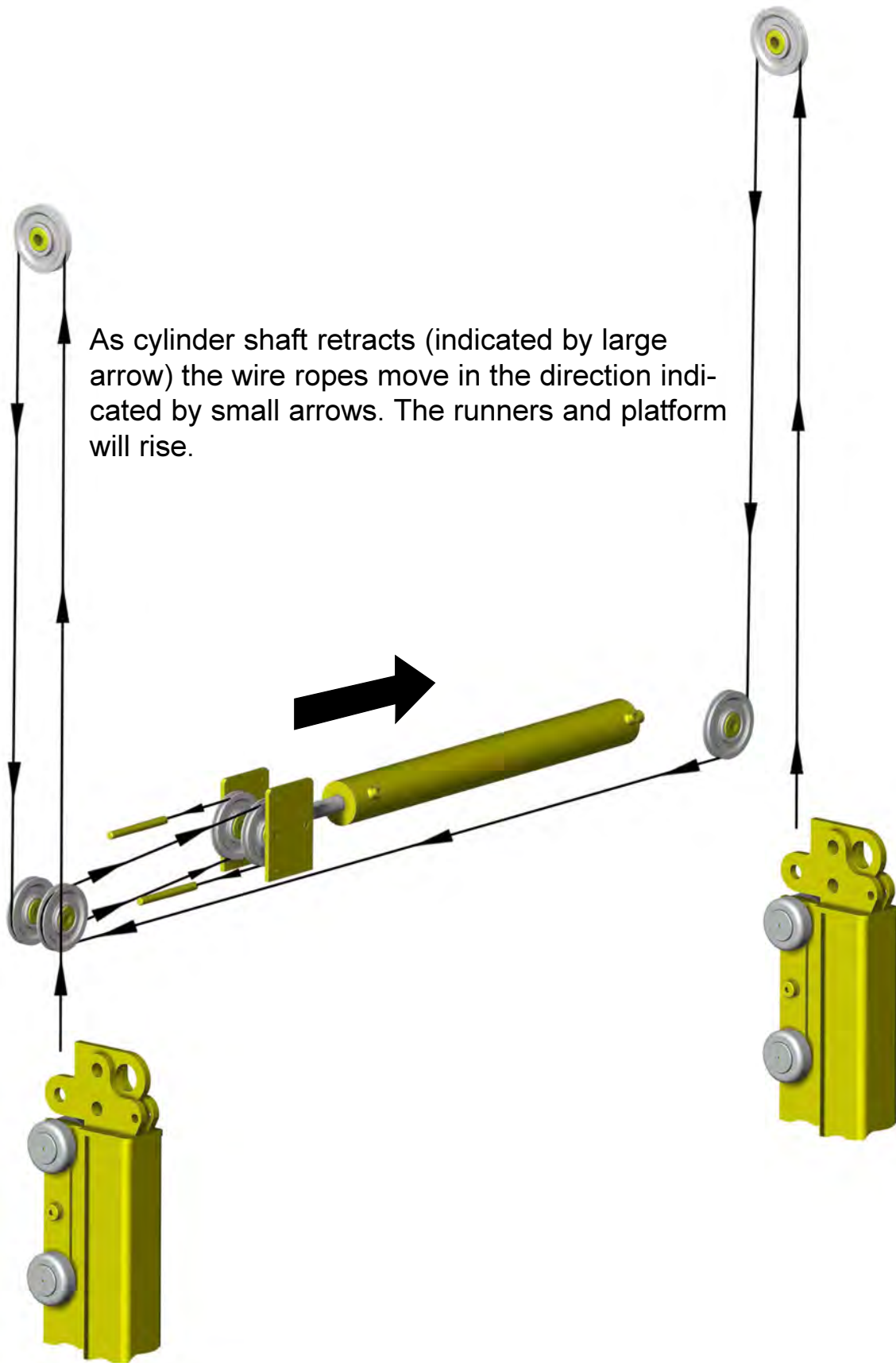

# WIRE ROPE MAINTENANCE

The most important assemblies in your unit are the wire ropes. These must be checked **every three months** for broken wires and for lack of lubrication, particularly in those areas where the wire ropes pass around the sheaves during the up & down movement of the platform.

Remove the covers from the tops of the column assemblies and from the main frame. Clean the wire rope area first, then make a visual check.

## **WARNING! DO NOT CHECK WIRE ROPES WITH FINGERS OR WHILE UNIT IS OPERATING.**

It will be necessary to run the platform through several cycles of operation (stopping the unit frequently), to enable you to inspect the required areas of wire rope. The wire rope (wire rope), is composed of several strands of individual wires, **See Figure 1**. Fatigue breaks occur in individual wires, (the breaks being square and usually in the crown of the strands). See **Figure 2**

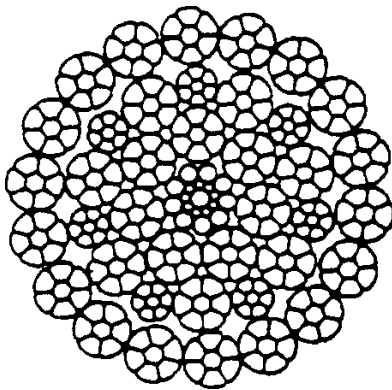

**Figure 1**

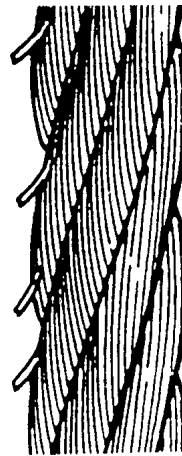

**Figure 2**

The wire rope comes from the factory internally lubricated, however, if during your inspection the wires look dry, then greasing with automobile type grease can prolong the life of the wire rope.

If 6 or more wires are broken in any 2-1/2" length of wire rope, the wire rope must be replaced. **See Wire Rope Replacement.** Note: The "WARNING" plate attached to the R.H. end of the Main Frame Cover gives explicit information regarding broken wires.

## WIRE ROPE ADJUSTMENT

Under normal operating conditions (using the unit to its rated capacity) the wire ropes should not require adjustment at the 3 month inspection period. However, it is suggested that the unit be CHECKED at this time, anyway.

.....

**Remove the cover from the main frame assembly.**

.....

Using the curb side remote control switch, raise the platform. Watch the tops of the runners, right and left hand side of the unit. BOTH runners should strike the stops in the column assemblies at the same time. Release the switch toggle. In the main frame assembly check the amount of rod extending from the cylinder barrel. There should be 1" (or more) showing. Under these conditions the wire ropes DO NOT require adjustment.

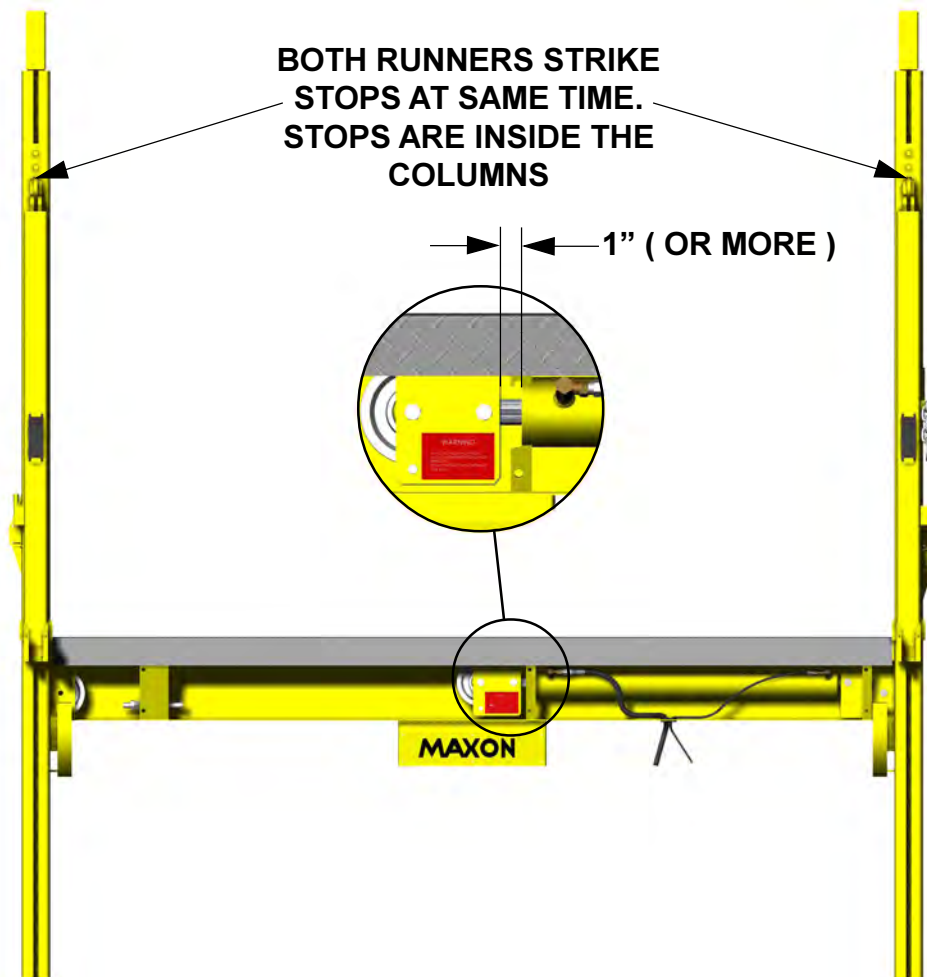

If one runner strikes the stop and the other does not, indicates that the wire rope has stretched on the runner which does not strike the stop, or the cylinder rod has bottomed out in the barrel. Measure the gap between runner and stop. Adjust per instructions on the next page.

## WIRE ROPE ADJUSTMENT (Cont'd.)

If the LEFT HAND runner is not touching the stop then the LEFT HAND wire rope will require adjustment.

If the RIGHT HAND runner is not touching the stop the RIGHT HAND wire rope will require adjustment. Proceed as described below.

.....  
**Lower platform to the ground .**  
.....

LEFT HAND  
(STREET SIDE)

WIRE ROPE GUIDE

JAM NUT

RIGHT HAND  
(CURB SIDE)

ADJUSTING NUT

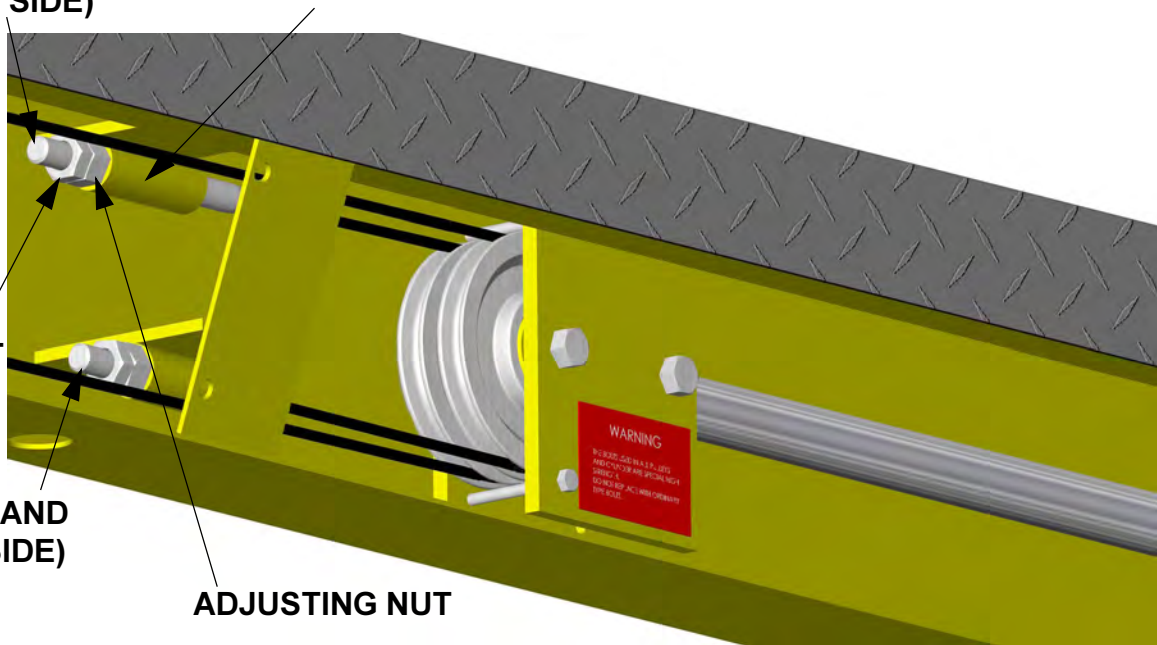

### **NOTE! LEFT HAND WIRE ROPE ADJUSTMENT IS ILLUSTRATED.**

If the *right hand* wire rope was the one to be adjusted the procedure is the same, except the *lower wire rope fitting*, (RH side), would be the one to adjust.

Loosen the jam nut. With a wrench, screw adjusting nut in a clockwise direction to pull wire rope fitting thru the guide. If the gap between runner and stop was 3/8" (for example) then adjust nut against guide until 3/8" of wire rope fitting has been pulled thru the guide.

It may not be possible to obtain the correct adjustment the first time. Operate the unit and check the runners. If both runners touch the stops at the same time and 1" of cylinder rod shows from the barrel, the adjustment is correct. If not, lower platform to ground and adjust accordingly on adjusting nut. Operate unit and re-check. When adjustment is correct, tighten jam nut.

# CAM FOLLOWER ADJUSTMENT

ADJUSTMENT OF THE CAM FOLLOWER MUST BE DONE BY THE FOLLOWING STEPS:

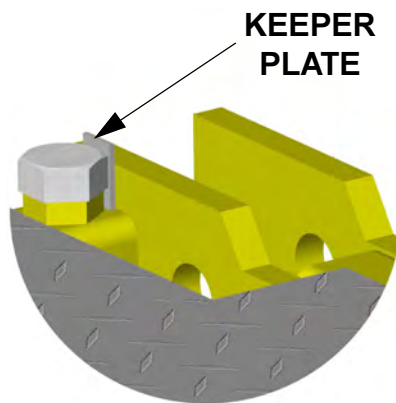
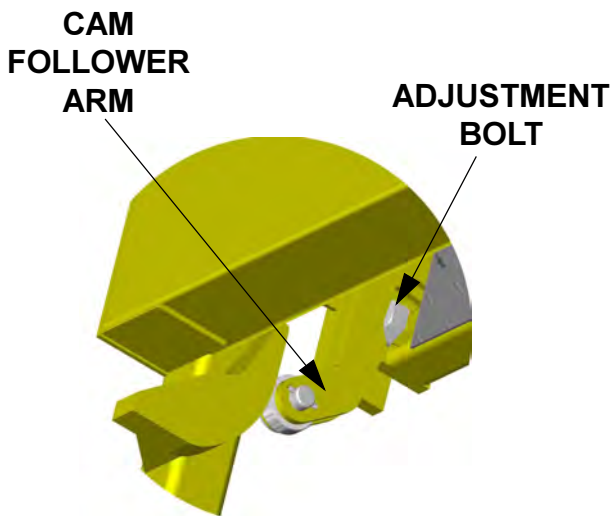
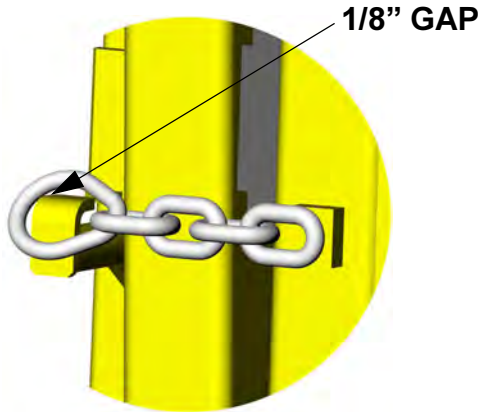

1. ROTATE THE PLATFORM CLOSER HANDLE CLOCKWISE UNTIL THE CAM FOLLOWERS ARE AGAINST ADJUSTMENT BOLTS.
2. RAISE THE PLATFORM TILL ONE OF THE CAM FOLLOWER ARMS IS TOUCHING THE ADJUSTMENT BOLT.
3. UNSCREW THE OPPOSITE SIDE ADJUSTMENT BOLT UNTIL IT TOUCHES THE CAM FOLLOWER ARM.
4. CONTINUE TO RAISE THE PLATFORM UNTIL IT REACHES UP STOPS. ENGAGE THE PLATFORM RETENTION CHAIN.
5. IF YOU CAN'T ENGAGE THE CHAIN, UNSCREW BOTH CAM FOLLOWER ADJUSTMENT BOLTS A LITTLE MORE.
6. REPEAT STEP 4 AND 5 UNTIL THE CHAIN IS ENGAGED.
7. OPEN THE PLATFORM AND BEND THE KEEPER PLATE AGAINST THE FLAT EDGE OF THE BOLTS.

NOTE: THE CAM FOLLOWER SHOULD NOT BE ADJUSTED TO THE POINT WHERE THE CHAIN ENGAGES LOOSELY. 1/8" GAP FROM CHAIN TO PIN IS SUFFICIENT.

## 3 MONTH MAINTENANCE SCHEDULE

1. CHECK THE HOSE FOR CRACKING AND LEAKS.
2. CHECK THE ELECTRICAL WIRING FOR CONTINUITY AND THE WIRE ROPE ENDS FOR CORROSION.
3. VISUALLY CHECK THE COMPLETE UNIT FOR EXCESSIVE WEAR, WORN PARTS, REFORMED OR BROKEN STRUCTURES OR BROKEN WELDS. FOR PARTS REPLACEMENTS SEE BREAKDOWN DRAWING FOR YOUR UNIT IN SECTION 4 OF THIS MANUAL.
4. CHECK ALL BOLTS FOR TIGHTNESS.
5. CHECK THAT ALL WARNING DECALS ARE IN PLACE AND READABLE.
6. CHECK THAT ALL ROLL PINS ARE PROPERLY INSTALLED. REPLACE IF NECESSARY.
7. GREASE ALL AREAS THAT GREASE FITTING IS PROVIDED.
8. INSPECT THE WIRE ROPE.
9. DO NOT PUT GREASE ON THE COLUMNS. IT CAUSES THE ROLLER TO SLIDE RATHER THAN ROLL.

### \* COLD WEATHER OPERATION

#### **OIL SPECIFICATIONS:**

Grade ISO-(32)  
Gravity, API - 29.5 Degrees  
Pour Point, F- (-54 Degrees)

#### **VISCOSITY:**

@ 40 Degrees C - 31.2 cSt  
@100 Degrees C - 6.2 cSt  
VISCOSITY INDEX - 154 VI  
Flash Point, F - 325 Degrees

# PARTS REPLACEMENT

# WIRE ROPE REMOVAL

Determine which wire rope needs replacing. **NOTE!** Both wire ropes will usually wear out at the same time, therefore WE RECOMMEND that both wire ropes be changed at the same time.

The following instructions cover changing BOTH wire ropes. If only one wire rope is changed, use the appropriate sections for that wire rope.

**NOTE:** Be sure to save all parts that you remove as they are to be reused when the unit is reassembled.

1. Lower Platform to ground. Remove two bolts from the Runner Lug and the Cable Link Adapter.

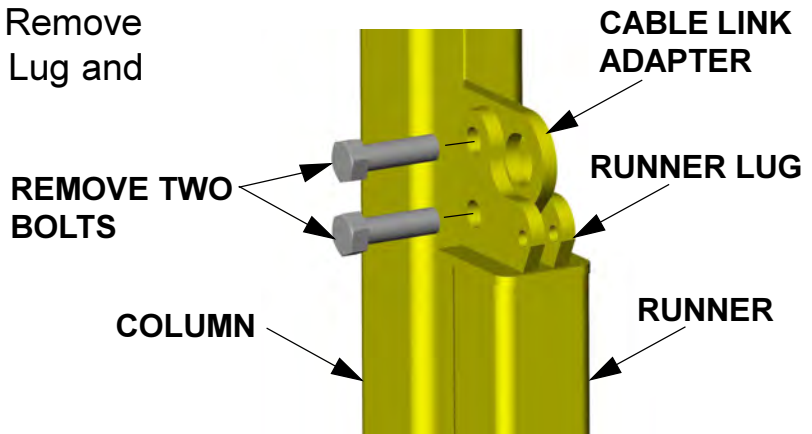

2. Remove the sheave covers from top of column. Before removing the 3/8" bolts holding the stop plates to the column, wedge a screwdriver underneath the plates. Loosen or remove bolts and lock washers and ease stop plates out of the column.

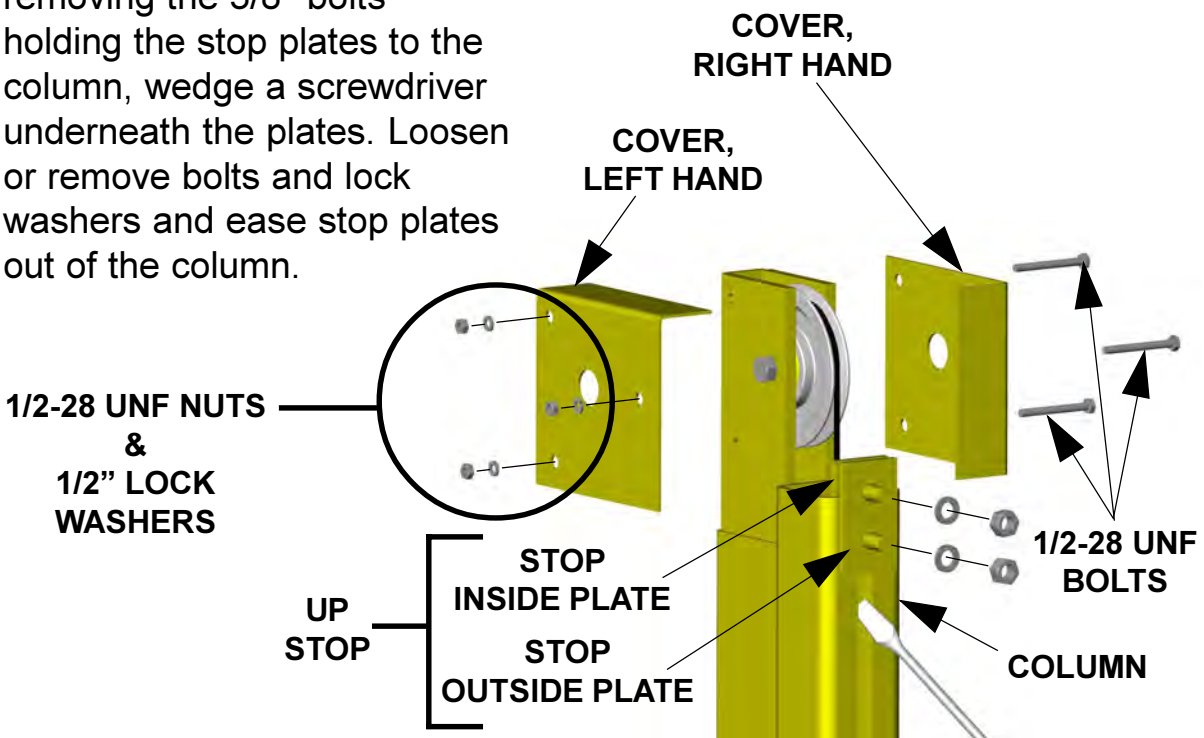



## WIRE ROPE REMOVAL (Cont'd.)

3. Remove the sheaves from the tops of the Column assemblies. Check the bolts for wear in the area where the sheave has been rotating. If the bolts are worn, they must be replaced.

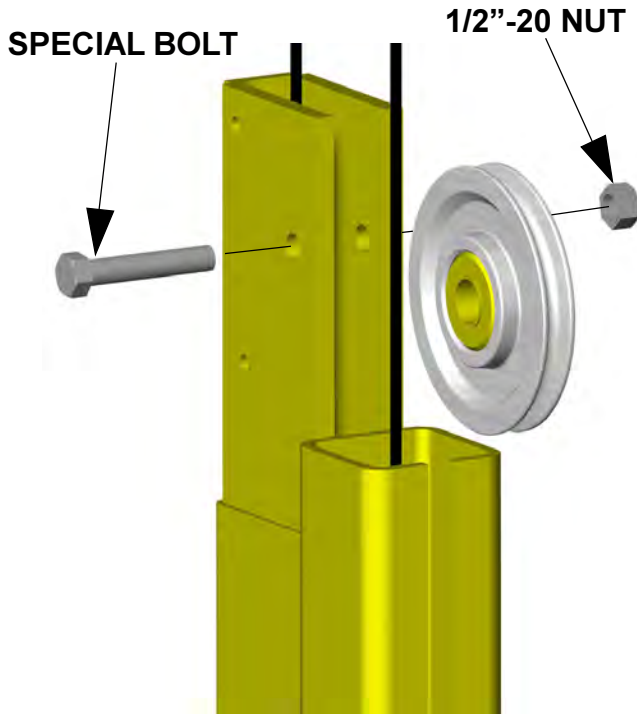

### **WARNING!**

THESE ARE SPECIAL BOLTS AND COMMON STOCK BOLTS CAN NOT BE SUBSTITUTED. ORDER THESE BOLTS BY THE PART NUMBER. FOR RC-2000 UNITS P N 202438. FOR RC-3000/4000 UNITS USE P/N 202465. FOR RC-5000/6000 USE P/N 202465.

4. Check the sheaves to see if they have been badly nicked or chipped in the areas where the cable lays. If they need replacing, see the parts breakdown for your unit to obtain the correct part number.

### **NOTE!**

THE ABOVE WARNING AND CHECKS APPLY TO ALL SHEAVE AND SHEAVE BOLTS INSTALLED TO YOUR UNIT.

- 
5. With the stops removed, the brake assembly can be pulled out of the Column. The wire rope end fitting can now be removed from the upper portion of the brake assembly.

### **NOTE!**

IT IS NOT NECESSARY TO REMOVE THE LOWER BOLT FROM THE BRAKE ASSEMBLY UNLESS BRAKE IS BEING REPLACED.

The wire rope can hang out over the top of the Column assembly.

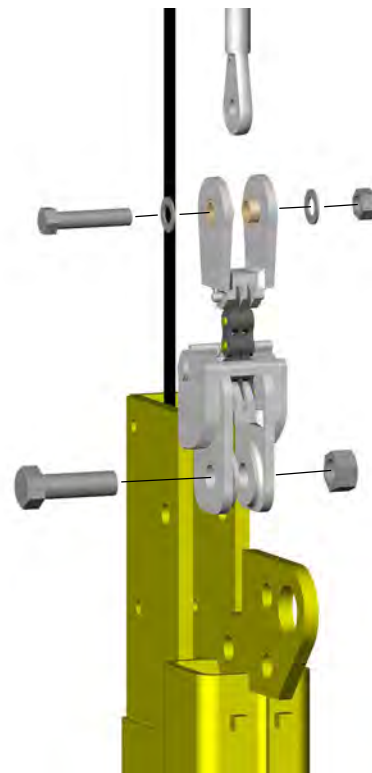

## WIRE ROPE REMOVAL (Cont'd.)

6. Remove main frame cover. If BOTH wire ropes are to be removed, ALL FIVE SHEAVES will need to be removed from inside the main frame assembly. The left column sheaves, the two cylinder sheaves and the right column sheave. Inspect sheaves for excessive wear and groves. Replace if needed.

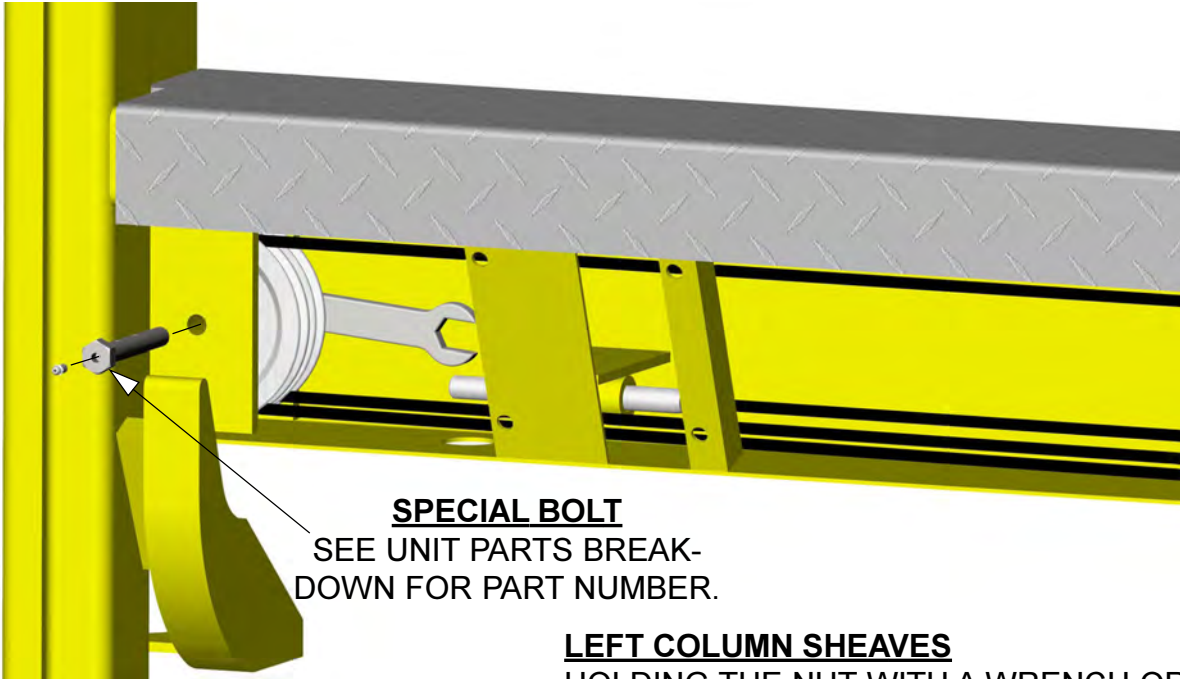

**SPECIAL BOLT**  
SEE UNIT PARTS BREAK-DOWN FOR PART NUMBER.

**LEFT COLUMN SHEAVES**  
HOLDING THE NUT WITH A WRENCH OR FINGER TIPS, REMOVE THE BOLT AND LOCK WASHER.

7. Remove both sheaves and spacer washers, (washers located between the sheaves for the RC-2 and RC-3 only.), from the anchor plates.

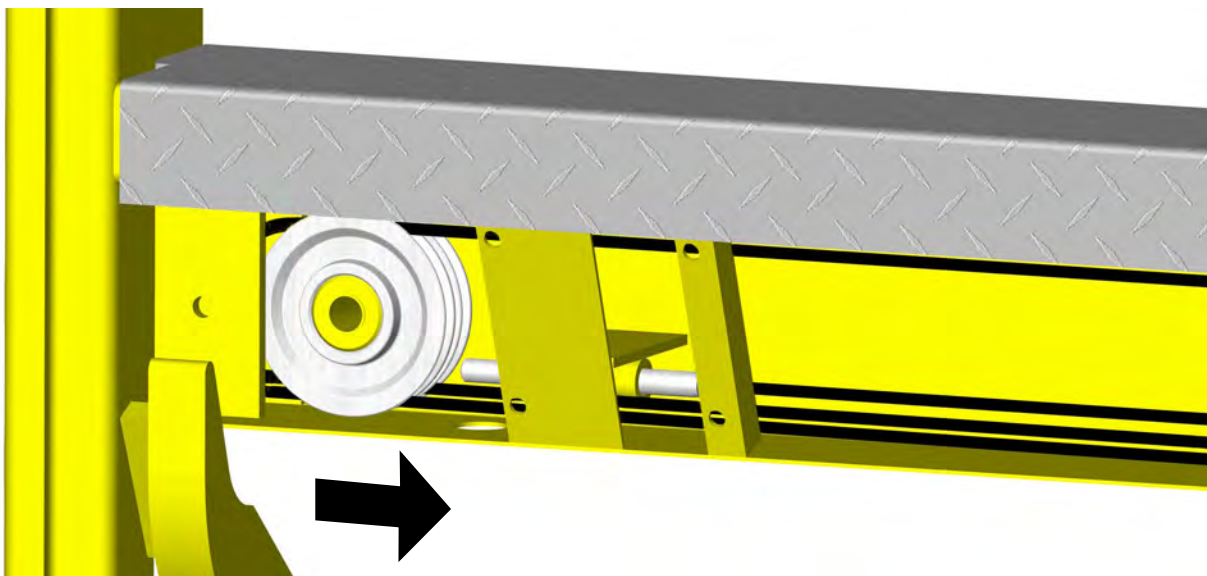

## WIRE ROPE REMOVAL (Cont'd.)

8. In the same manner shown for the left column sheaves, remove the bolt and lock washer holding the sheaves in the cylinder anchor plates. (Special bolt. See breakdown drawing for part number.) Pull the sheaves out of the anchor plates. At the same time slide the wire rope end fitting to the left. The sheaves can now be removed.

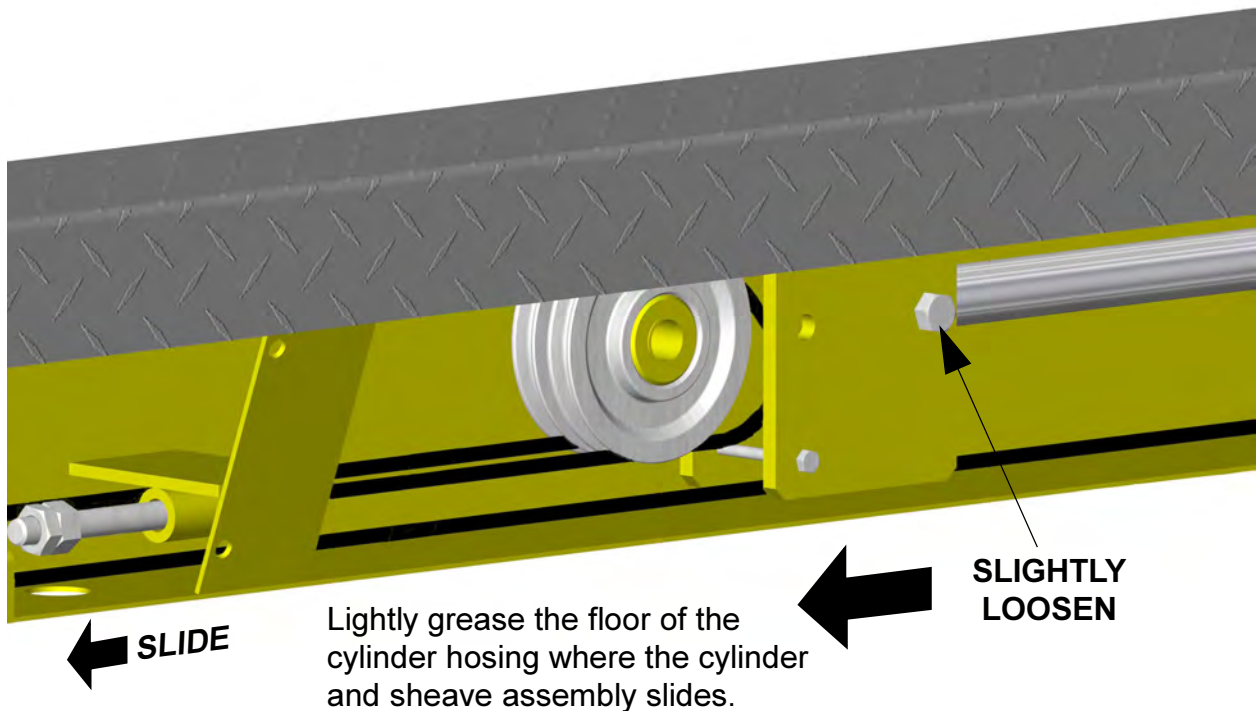

9. To obtain access to the Right Column sheave, remove the bolt holding the butt end of the cylinder in the anchor plates. Slide the complete cylinder assembly to the left.

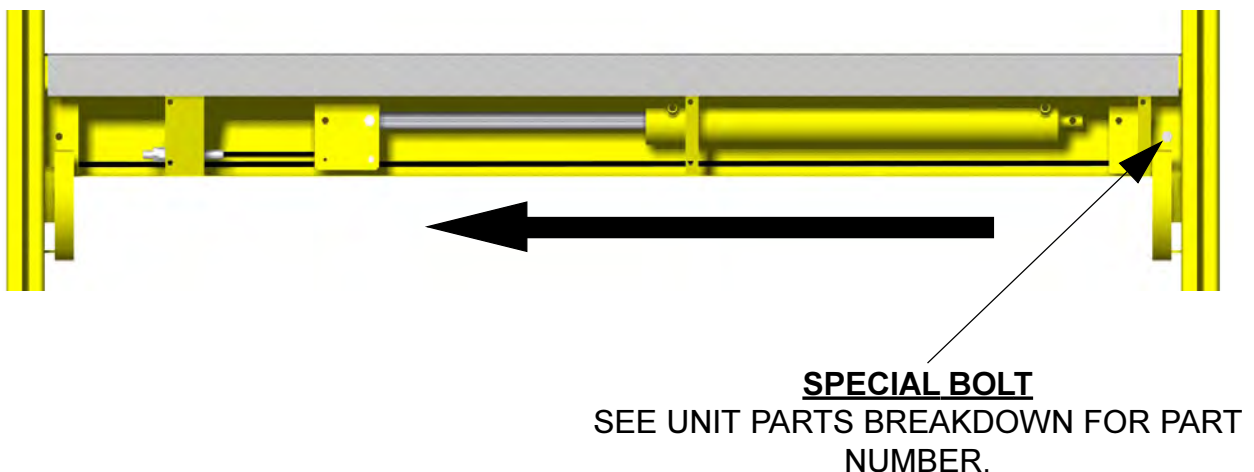

## WIRE ROPE REMOVAL (Cont'd.)

10. The sheave bolt can now be removed in similar manner to the other sheave bolts. Slide the sheave out of the anchor plates.

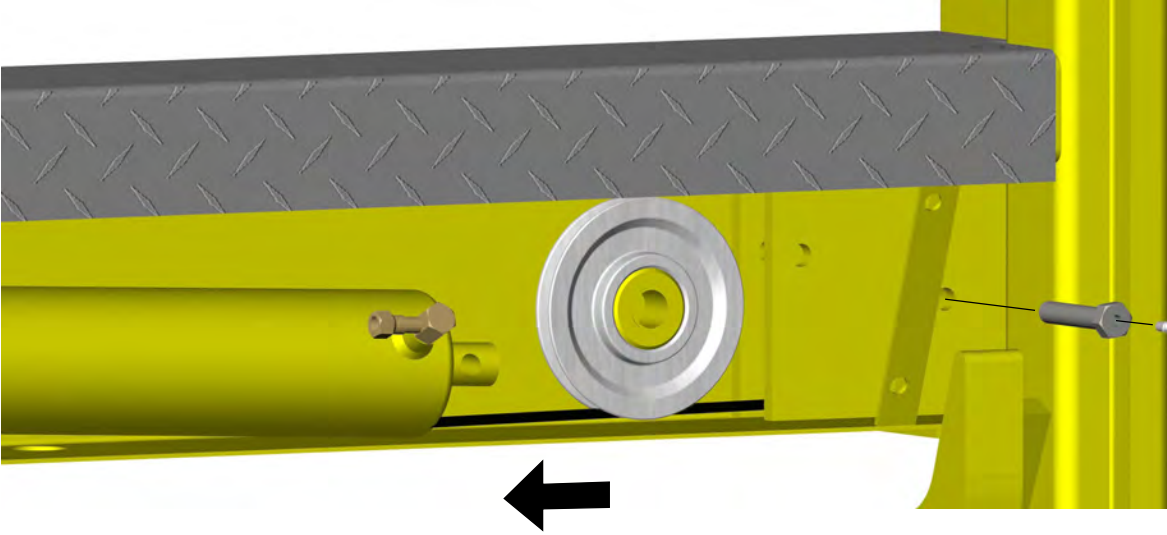

11. Slide the complete cylinder assembly to the right.

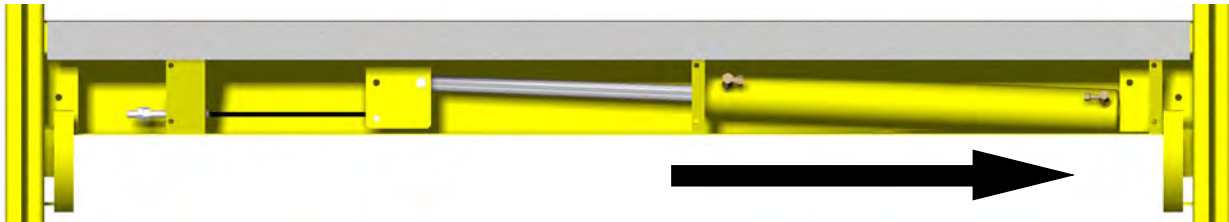

12. Remove the nuts from both wire rope end fittings. Pull the wire rope end fittings out of the tubes. From the top of each Column assembly, pull the wire ropes up and out of the unit.

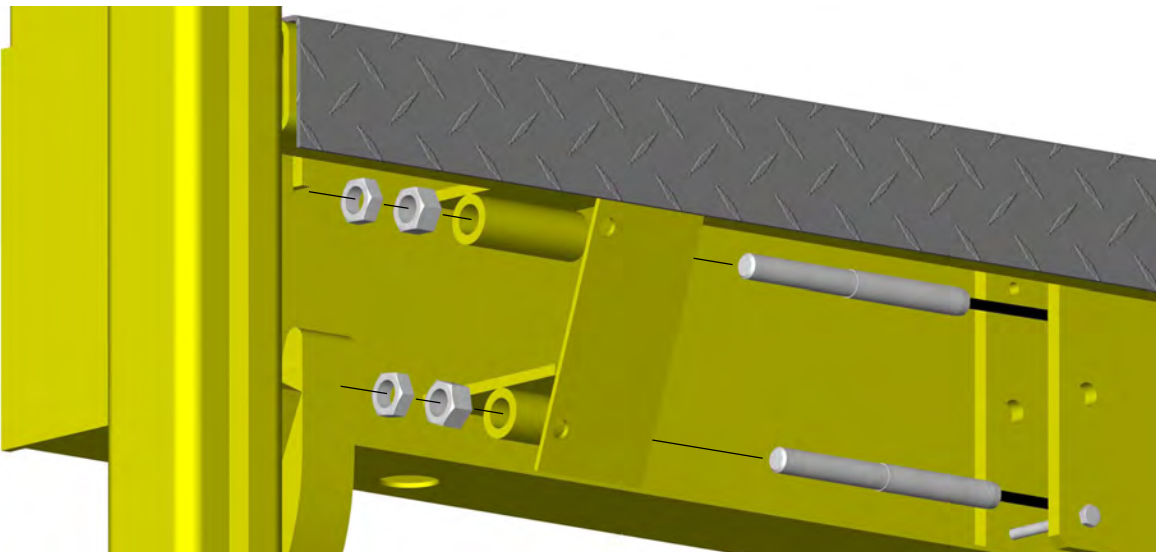

**MAXON**<sup>®</sup>

11921 Slauson Ave. Santa Fe Springs, CA. 90670 (800) 227-4116 FAX (888) 771-7713

## WIRE ROPE REPLACEMENT

1. Install the left hand wire rope first. This is the shortest of the two wire ropes. Insert the wire rope end fitting (threaded end) down into the cable enclosure.

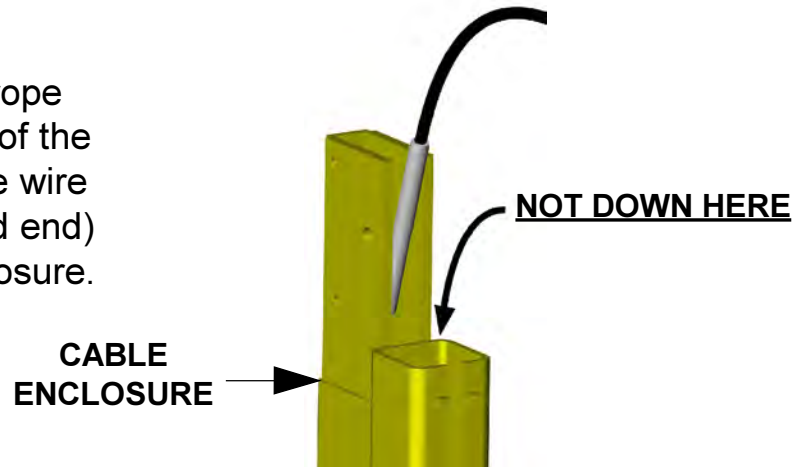

2. When the wire rope end reaches the bottom of the column, use a length of bent wire to fish the wire rope out into the main frame assembly.

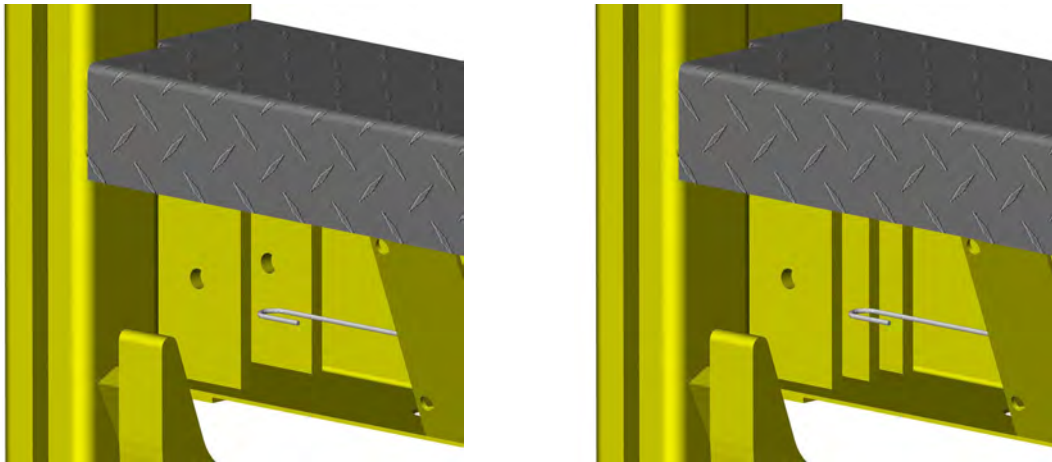

3. Pull approximately 3 feet of wire rope into the main frame assembly. Insert the threaded end of the wire rope into the top tube of the wire rope end retainer assembly. Install one nut to the wire rope end.

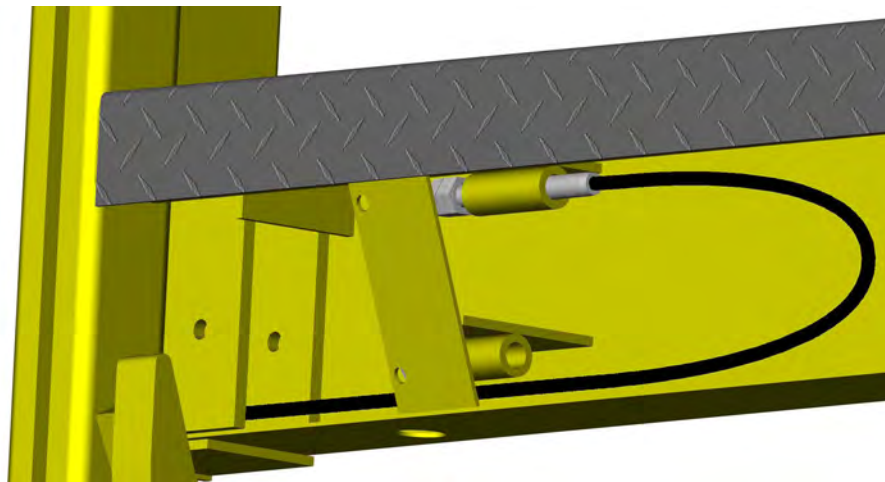

## WIRE ROPE REPLACEMENT (Cont'd.)

4. Install the sheave to the top of the left Column Assembly. Install the wire rope fitting to the Runner Links.



5. For the longer wire rope installation on the right hand column, use the same procedure that you used for the left hand column. Approximately 11 to 12 feet of wire rope will need to be pulled into the main frame assembly. To give a clearer picture, the illustration shows what will be the final lay of the right hand wire rope.

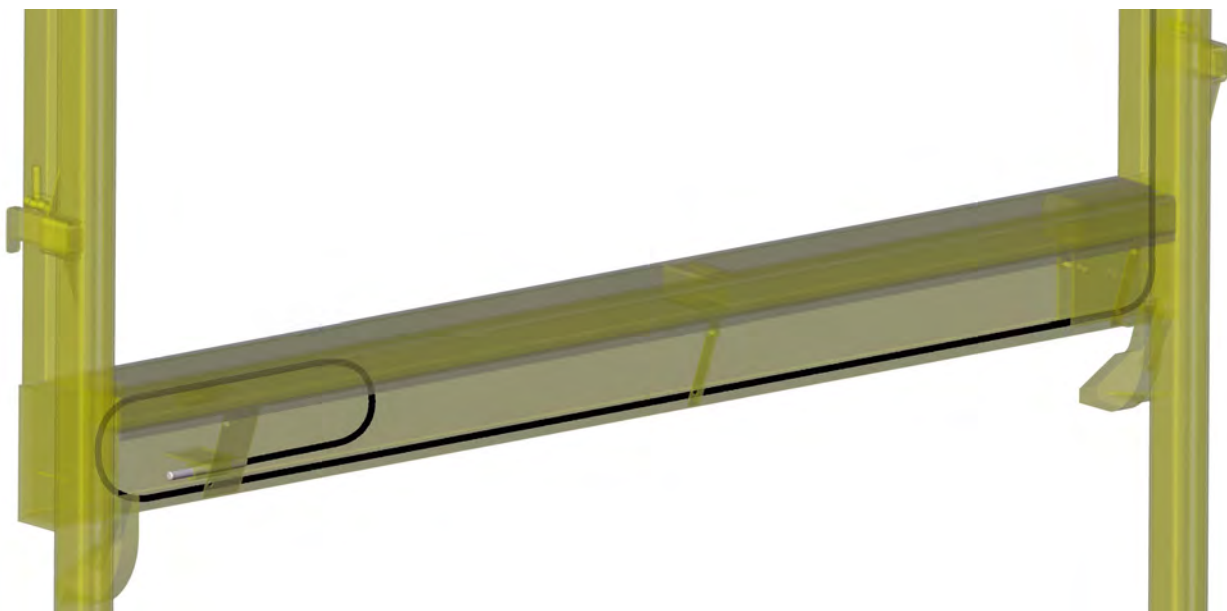

**MAXON**<sup>®</sup>

11921 Slauson Ave. Santa Fe Springs, CA. 90670 (800) 227-4116 FAX (888) 771-7713

## WIRE ROPE REPLACEMENT (Cont'd.)

6. Insert the threaded end of the wire rope into the bottom tube of the wire rope end retainer assembly. Install one nut to the wire rope ends.

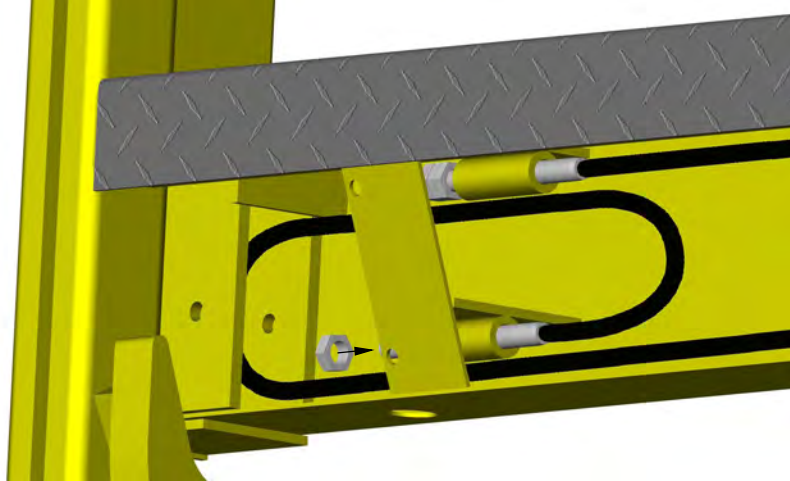

7. Repeat the same procedure for the right side pulley that you used for the left side.
8. Install the 2 left column sheaves inside the main frame assembly. Be sure the wire ropes are seated in the grooves of the sheaves. To start the nut on the bolt hold the nut between the fingers and insert behind the sheave anchor plate. Finish tightening nut with a wrench. **NOTE: THE LOCK WASHER IS UNDER THE HEAD OF THE BOLT.**

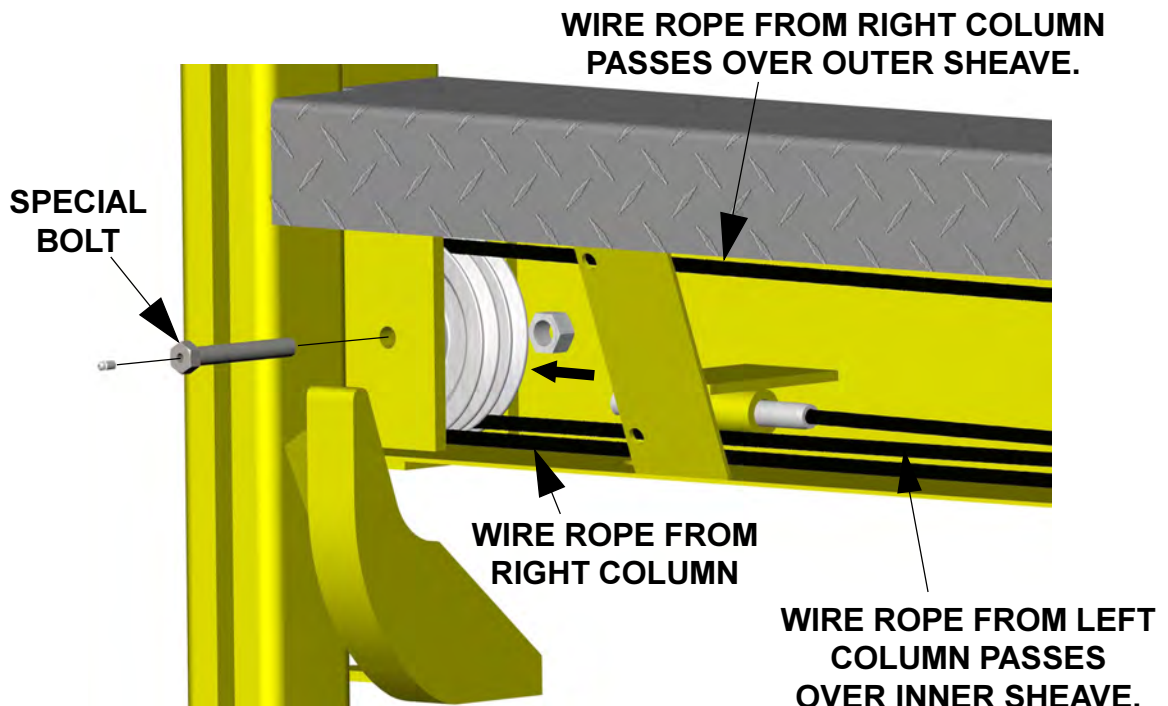

**NOTE:** For RC-2 & RC-3 Pulley Assemblies, see next page.

# WIRE ROPE REPLACEMENT (Cont'd.)

## PULLEY ASSY FOR RC-2/3 ON CYL. ROD END AND LOWER LEFT HAND PULLEY BRACKET

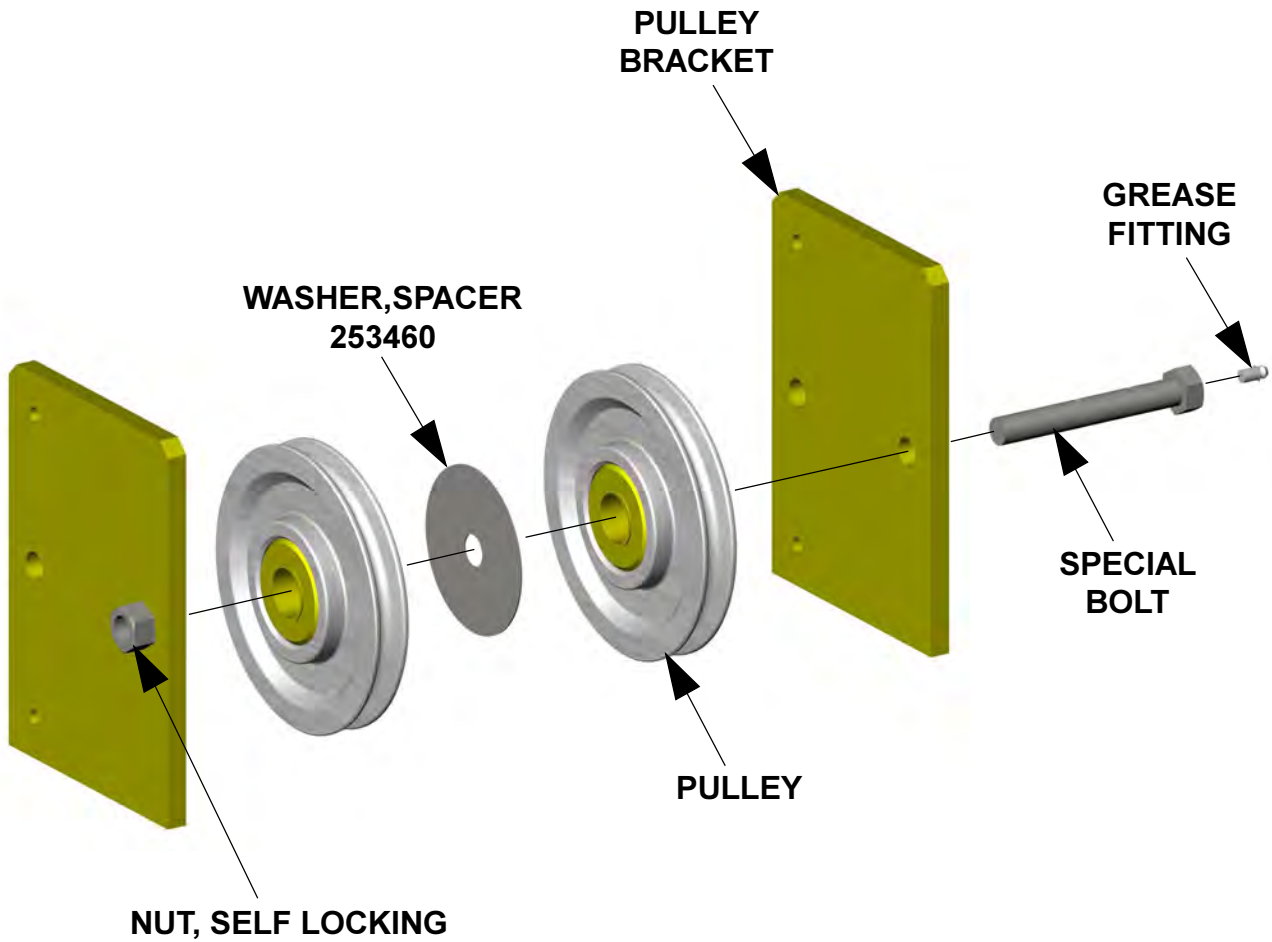

**MAXON**<sup>®</sup>

11921 Slauson Ave. Santa Fe Springs, CA. 90670 (800) 227-4116 FAX (888) 771-7713



## WIRE ROPE REPLACEMENT (Cont'd.)

9. Move cylinder assembly to the left. Install the right column sheave. Be sure the wire rope is seated in the groove. The sheave is installed in the identical manner as the left column sheave.

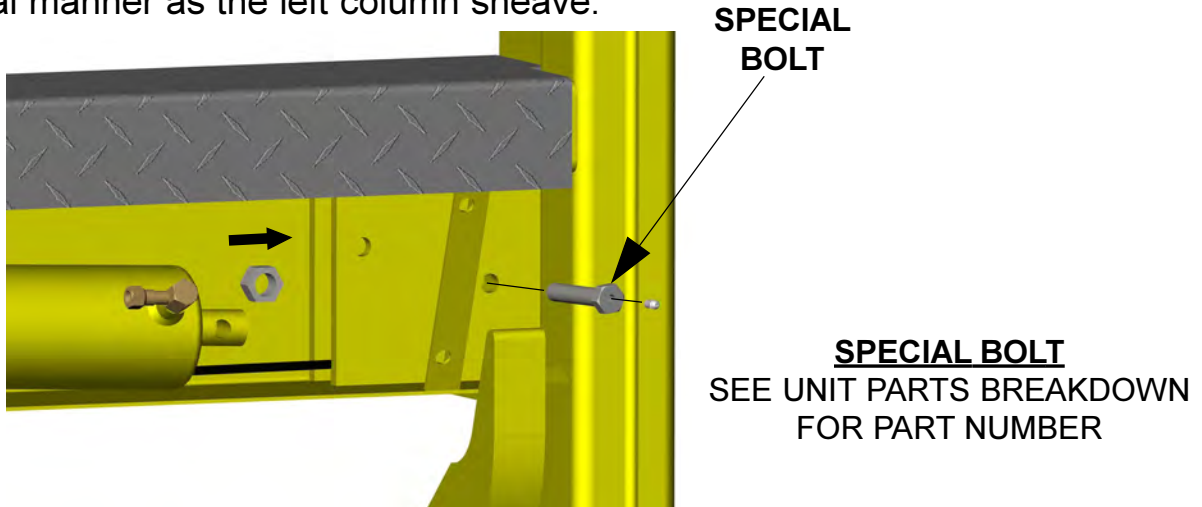

10. Install the butt end of the cylinder to the right hand anchor plate. This bolt is identical to the right hand sheave bolt. **IT IS A SPECIAL BOLT. NO SUBSTITUTION ALLOWED.**
11. Install the two cylinder anchor plate sheaves. Be sure that BOTH wire ropes are seated in the grooves. The sheave bolt **IS A SPECIAL BOLT. NO SUBSTITUTION ALLOWED.**
12. The right and left hand runners can now be un-clamped and lowered down the column assemblies. This will take up most of the slack in the wire rope.

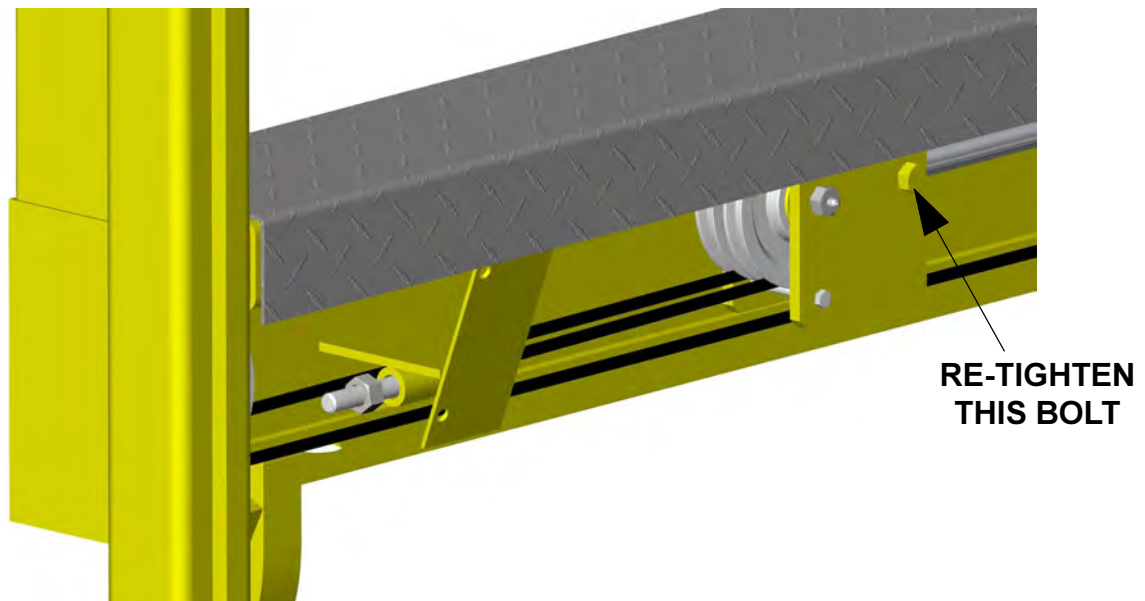

## WIRE ROPE REPLACEMENT (Cont'd.)

13. Install the remaining two nuts to the cable end fittings. Run the nuts down on the cable fittings to take up the remaining slack.

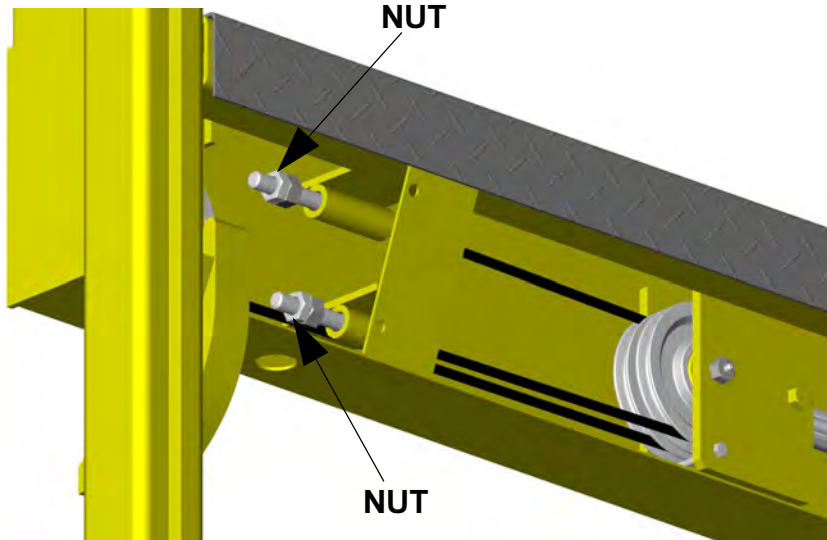

### **WARNING**

CHECK THAT ALL BOLTS ARE TIGHT BEFORE OPERATING UNIT.

14. Stop plates must be installed in each column. The outside stop plates fit under and flush against the blocks welded to columns. The outside stop plates are the same for all MAXON rail lifts.

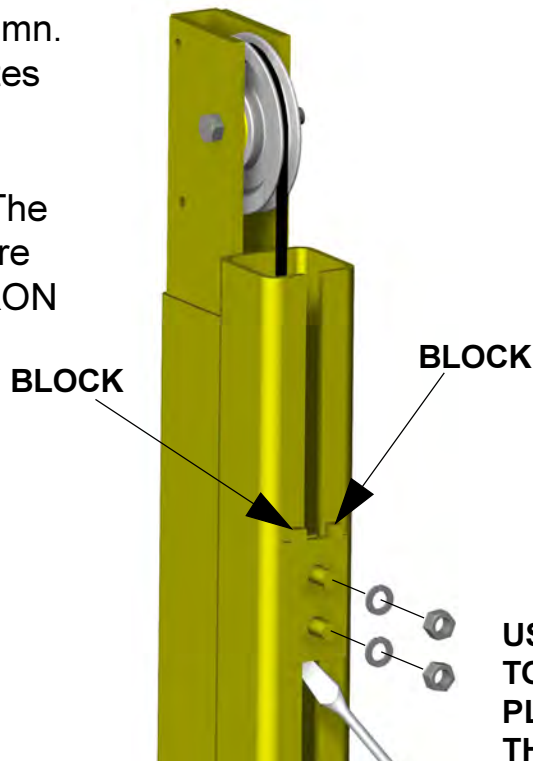

USE A SCREWDRIVER TO EASE STOP PLATES INTO COLUMN. THEN INSTALL BOLTS AND LOCK WASHERS.

**MAXON**<sup>®</sup>

11921 Slauson Ave. Santa Fe Springs, CA. 90670 (800) 227-4116 FAX (888) 771-7713

# ADJUSTING NEW WIRE ROPES

Using curb side control switch raise platform until it is almost on a level with the top surface of the main frame assembly.

**DO NOT ALLOW RUNNERS TO HIT STOPS.**

Release toggle switch, Check that the platform is level. If it is not level the required wire rope will need to be adjusted to bring platform level. See illustrations below. Platform can be lowered to make the adjustment.

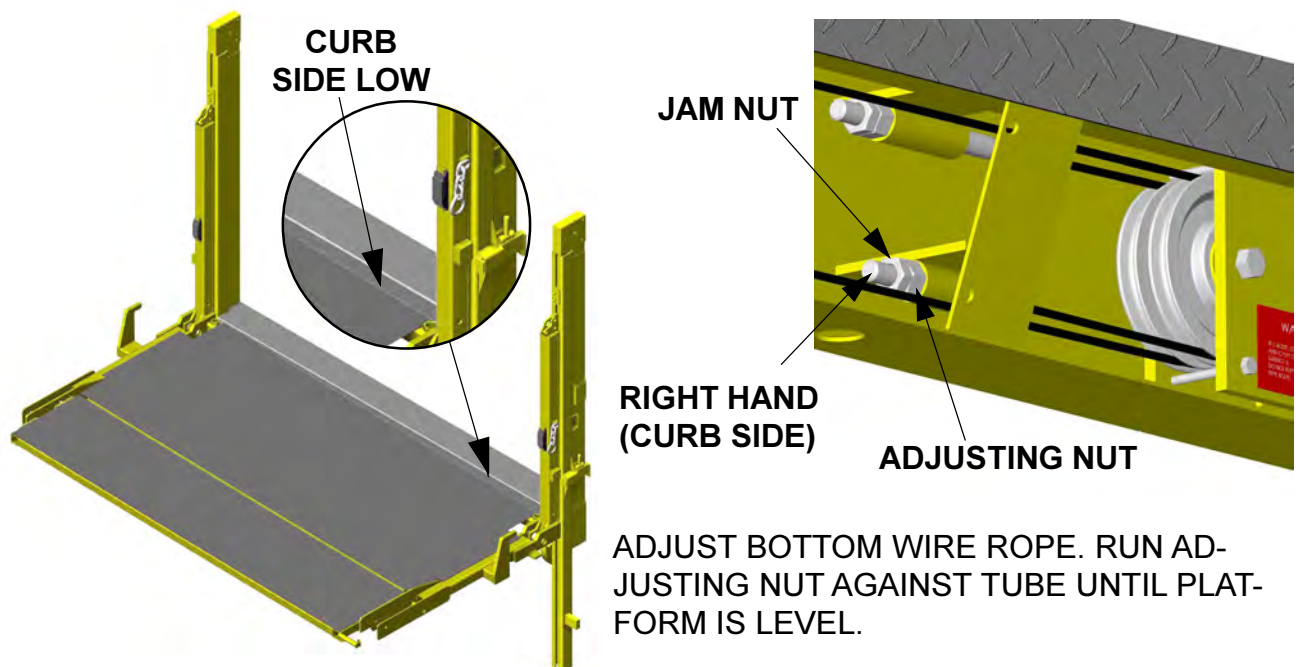
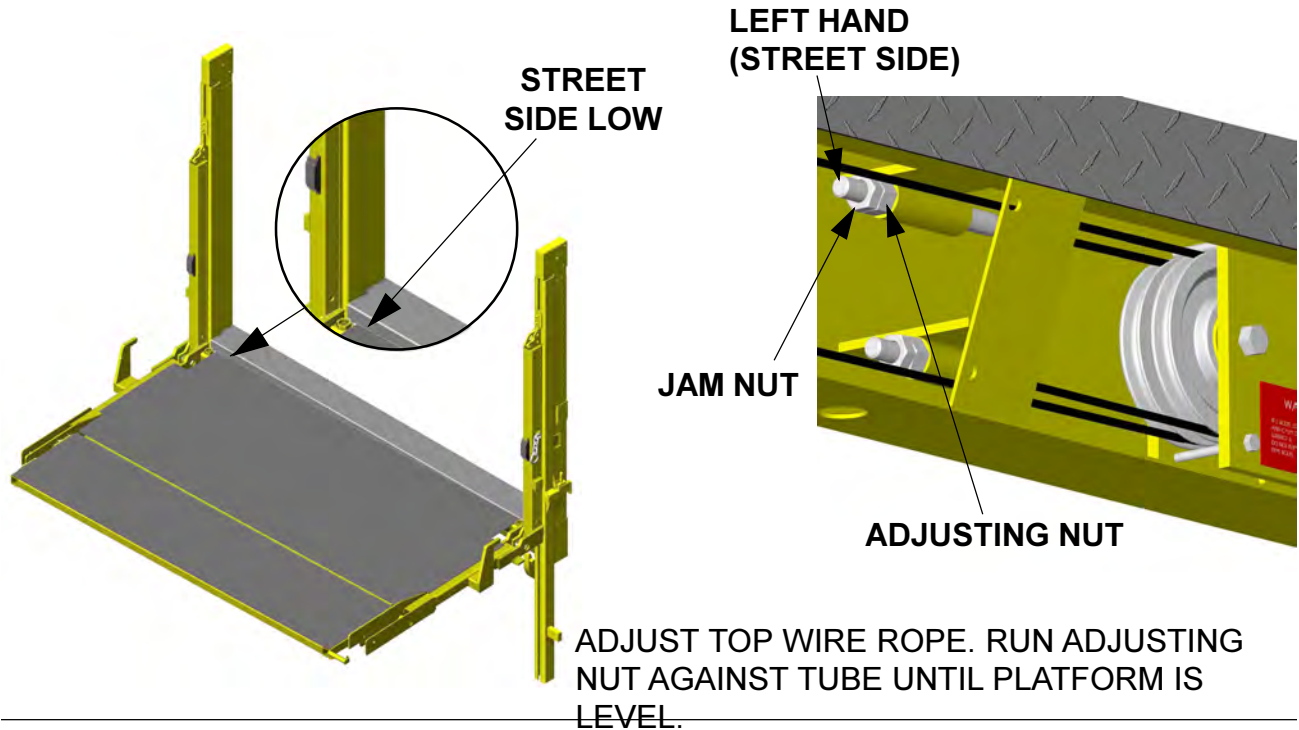

## ADJUSTING NEW WIRE ROPES (Cont'd.)

1. USING CURB SIDE SWITCH, RAISE PLATFORM UNTIL TOPS OF RUNNERS ARE ABOUT 1/4" FROM THE STOPS IN THE COLUMN ASSEMBLIES. RELEASE TOGGLE SWITCH. **DO NOT ALLOW TOPS OF THE RUNNERS TO HIT STOPS. THERE MUST BE A GAP.**
2. CHECK THE AMOUNT OF CYLINDER SHAFT EXTENDING FROM THE BARREL. THERE SHOULD BE 1-1/8" (MIN). IF YOU DO NOT HAVE THIS DIMENSION "BOTH WIRE ROPES WILL REQUIRED ADJUSTING EQUALLY TO GIVE THIS DIMENSION".
3. RUN PLATFORM UP TO MAIN FRAME ASSEMBLY AND CHECK THAT PLATFORM IS STILL LEVEL. ADJUST APPROPRIATELY IF NECESSARY.  
**THE OBJECT OF THE NEXT ADJUSTMENT IS TO ALLOW THE CURB SIDE RUNNER TO HIT THE STOP 1/2" BEFORE THE STREET SIDE RUNNER. THIS ADJUSTMENT IS MADE ON THE "LOWER" WIRE ROPE FITTING (RIGHT HAND, CURB SIDE WIRE ROPE).**
4. TIGHTEN THE ADJUSTING NUT AGAINST THE TUBE APPROXIMATELY 6-8 TURNS. RAISE PLATFORM. AS SOON AS THE CURB SIDE RUNNER TOUCHES THE STOP RELEASE THE SWITCH. CHECK THE DISTANCE BETWEEN THE TOP OF THE STREET SIDE RUNNER AND THE STREET SIDE STOP. IF THE MEASUREMENT IS 1/2" THE ADJUSTMENT IS CORRECT. IF IT IS NOT. LOWER THE PLATFORM AND ADJUST THE "LOWER" WIRE ROPE AGAIN. RAISE PLATFORM AND RELEASE SWITCH WHEN CURB SIDE RUNNER TOUCHES THE STOP. CHECK MEASUREMENT BETWEEN TOP OF STREET SIDE RUNNER AND ITS STOP. THIS ADJUSTMENT WILL PROBABLY HAVE TO BE MADE TWO OR THREE TIMES TO OBTAIN THE 1/2" DIMENSION.
5. WHEN ADJUSTMENT IS CORRECT, LOWER PLATFORM AND TIGHTEN STOP PLATE AND JAM NUT AGAINST ADJUSTING NUT ON BOTH WIRE ROPE FITTINGS.

### **NOTE!**

**WITH THIS ADJUSTMENT THE PLATFORM MAY TEND TO RIDE SLIGHTLY OUT OF LEVEL. THIS IS TEMPORARY. AFTER UNIT HAS BEEN IN OPERATION WITH LOADS ON PLATFORM, THIS WILL CORRECT ITSELF.**

6. REPLACE ALL COVERS. APPLY A LOAD (APPROXIMATELY 500 LBS) EVENLY DISTRIBUTED ON PLATFORM.
7. CYCLE LOAD UP AND DOWN ABOUT 20 TIMES. THIS WILL SEAT THE WIRE ROPES.
8. ADJUST IS NOW COMPLETE AND THE UNIT IS READY FOR USE.

# CYLINDER REPLACEMENT

1. LOWER PLATFORM TO GROUND. REMOVE COVER FROM MAIN FRAME ASSEMBLY. REMOVE THE CYLINDER BOLTS FROM THE SHEAVE ANCHOR PLATES. **NOTE!** THESE ARE “SPECIAL BOLTS” NO SUBSTITUTION IS ALLOWED. LOWER THE CYLINDER ONTO THE MAIN FRAME.

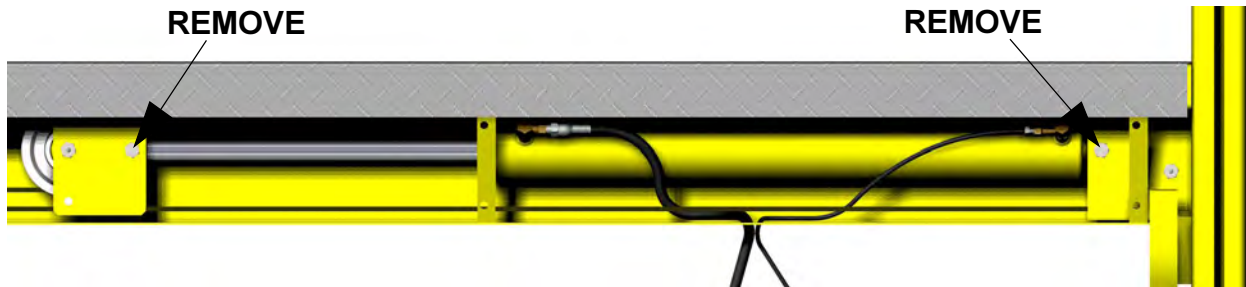

2. USING THE CURB SIDE REMOTE CONTROL MOVE TOGGLE SWITCH TO “RAISE” POSITION TO RETRACT THE CYLINDER SHAFT INTO THE BARREL. RELEASE SWITCH WHEN THE SHAFT IS APPROXIMATELY HALF WAY RETRACTED.

3. REMOVE THE HOSE FROM THE CYLINDER.

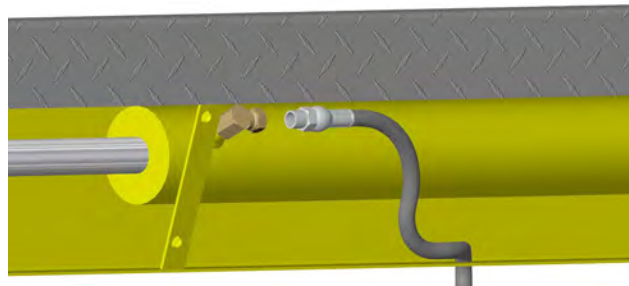

4. THE CYLINDER CAN NOW BE REMOVED FROM THE MAIN FRAME ASSEMBLY.

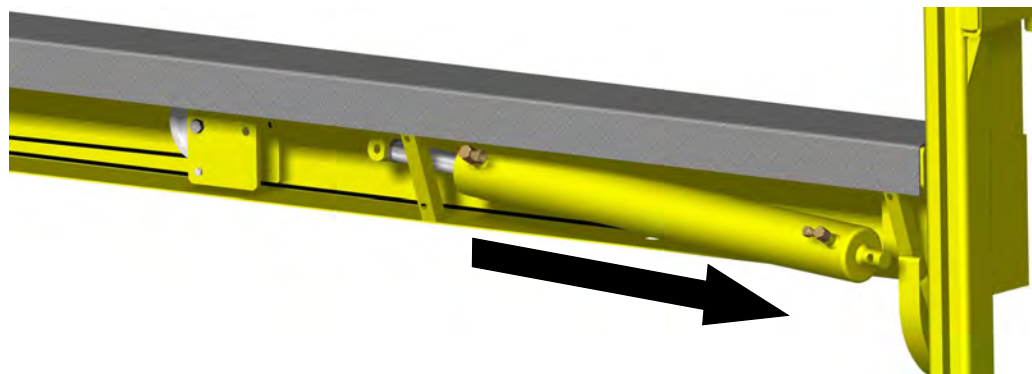

5. Cylinder replacement is the reverse of the removal instructions. **WARNING:** CHECK THAT ALL BOLTS ARE TIGHT.

**THIS PAGE IS INTENTIONALLY LEFT BLANK**

# PARTS BREAKDOWN DRAWINGS

# PARTS DRAWINGS (PAGE 1)

**MAXON**<sup>®</sup>

11921 Slauson Ave. Santa Fe Springs, CA. 90670 (800) 227-4116 FAX (888) 771-7713

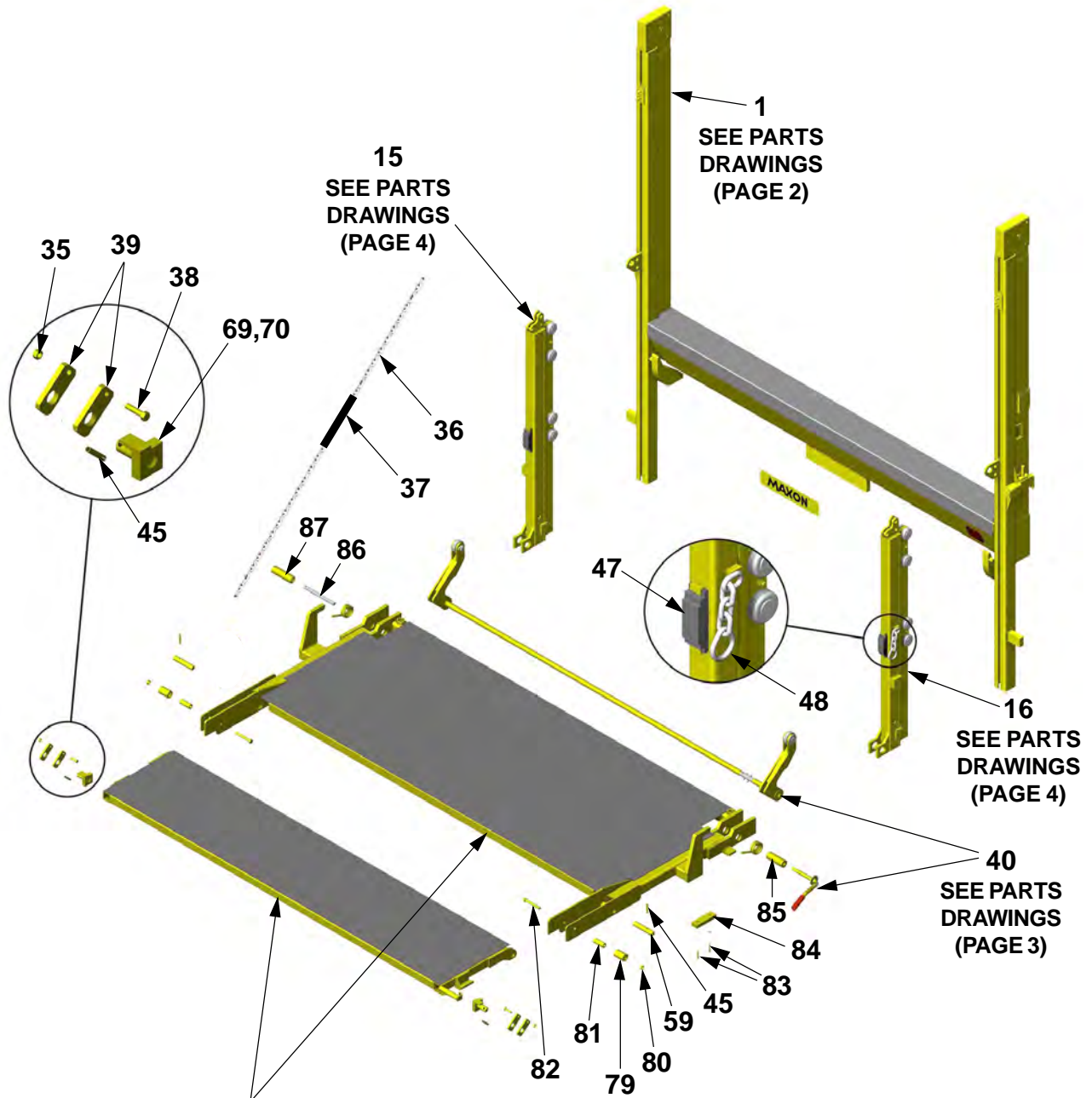



## PARTS DRAWINGS (PAGE 1)

ITEM	QTY.	PART NO.	DESCRIPTION
1	1	250908	MAINFRAME CLMN. ASY. 96" WIDE
		250908-04	MAINFRAME CLMN. ASY. 102" WIDE
15	1	251039-01	RUNNER ASSEMBLY, LEFT SIDE
16	1	251039-02	RUNNER ASSEMBLY, RIGHT SIDE
35	4	030041	BOLT, 3/8-24 UNF x 1-1/2" LG.
36	2	(SEE CHAIN CHART)	CHAIN
37	2	202840	HOSE, CHAIN
38	4	203853	NUT, 3/8-24 UNF SELF-LOCKING
39	4	202671	RUNNER LINK x 3-3/8"
45	5	221416	ROLL PIN, 3/8" x 2" LG.
47	2	227426	RUBBER BUMPER
48	1	250784	PLATFORM RETAINER (1 PC. PLTFM)
		252452	PLATFORM RETAINER (2 PC. PLTFM)
59	2	251859	PIN, FOLDING SECTION
69	1	222210-01	BRACKET, CHAIN ANCHOR
70	1	222210-02	BRACKET, CHAIN ANCHOR
79	2	223338	ROLLER, NYLON
80	2	901016-1	NUT, LOCKING 1/2-20
81	2	251889	BUSHING
82	2	202466	BOLT, 1/2-20 x 3-5/8" LG.
83	4	225279	SCREW, 1/4-14 x 1-1/2" LG.
84	2	225278-02	RUBBER BUMPER
85	1	253343	PIN, PLATFORM HINGE
86	1	221905	PIN, CAM FOLLOWER 7-3/4" LG.
87	1	221931	PIN, HINGE 1-1/2" x 4-7/8" LG.

### CHAIN CHART

	42" Platform	48" Platform	54" Platform	60" Platform	66" Platform	72" Platform
RC-2B,3B	202698-01 60" Chain	202698-02 64" Chain	202698-03 68" Chain	202698-04 72" Chain	202698-05 77" Chain	202698-06 82" Chain
RC-4B	202698-07 65" Chain	202698-08 69" Chain	202698-09 73" Chain	202698-05 77" Chain	202698-06 82" Chain	202698-10 86" Chain
RC-5B,6B				202698-11 84" Chain	202698-12 88" Chain	202698-13 92" Chain

	78" Platform	84" Platform	96" Platform
RC-5B	202698-14 97" Chain	202698-15 102" Chain	202698-16 112" Chain
RC-6B	202698-17 104" Chain	202698-18 108" Chain	202698-19 118" Chain

# PARTS DRAWINGS (PAGE 2)

**MAXON**<sup>®</sup> 11921 Slauson Ave. Santa Fe Springs, CA. 90670 (800) 227-4116 FAX (888) 771-7713

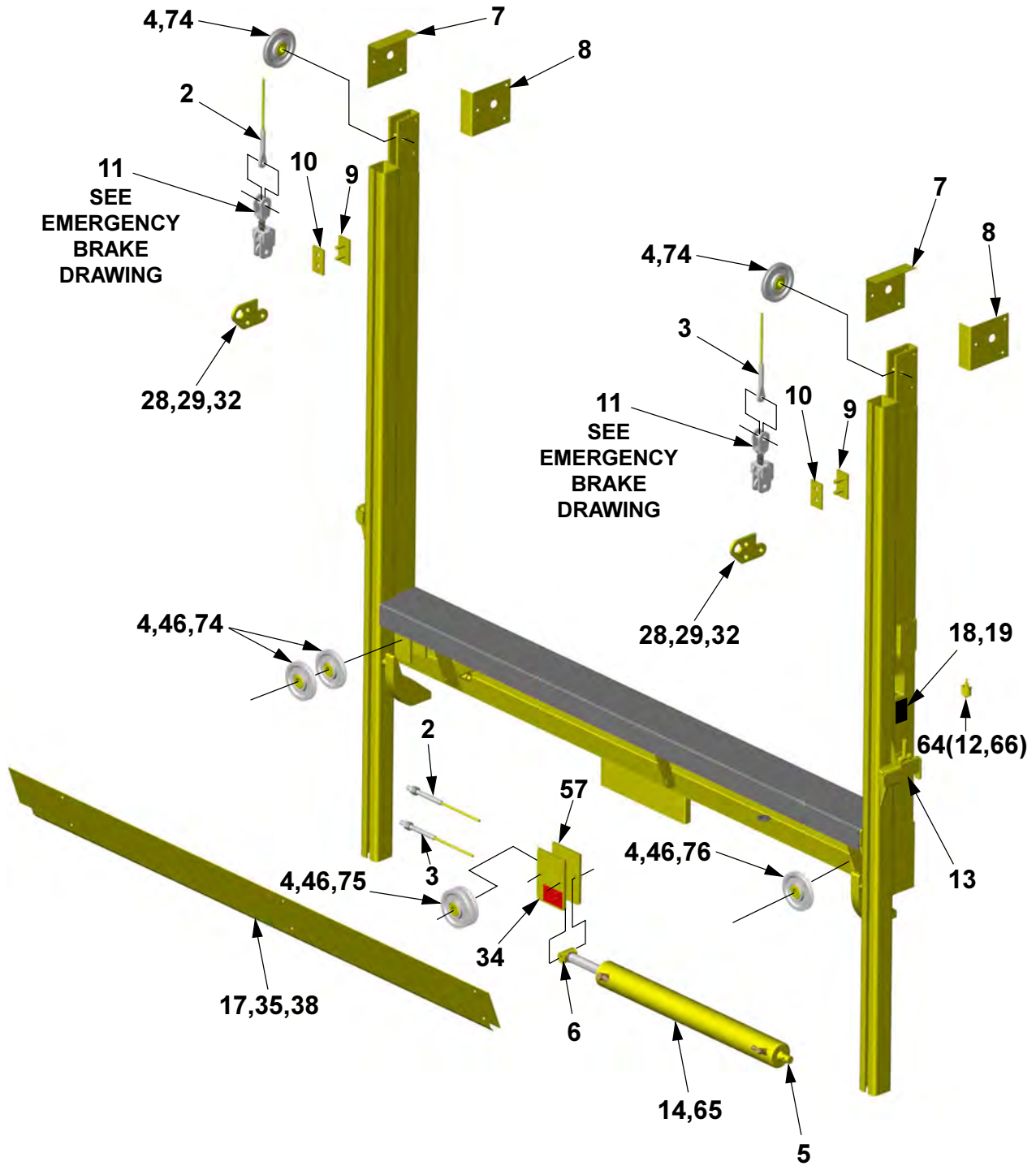

## PARTS DRAWINGS (PAGE 2)

ITEM	QTY.	PART NO.	DESCRIPTION
2	1	227191-01	WIRE ROPE ASSY. 96" WIDE RC-2B, RC-3B
		227192-01	WIRE ROPE ASSY. 102" WIDE RC-2B, RC-3B
		251588-01	WIRE ROPE ASSY. 96" WIDE RC-4B
		227190-01	WIRE ROPE ASSY. 102" WIDE RC-4B
		252402-01	WIRE ROPE ASSY. 96" WIDE RC-5B, RC-6B
		252403-01	WIRE ROPE ASSY. 102" WIDE RC-5B, RC-6B
		252401-01	WIRE ROPE ASSY. 96" WIDE RC-6K
		252400-01	WIRE ROPE ASSY. 102" WIDE RC-6K
3	1	227191-02	WIRE ROPE ASSY. 96" WIDE RC-2B, RC-3B
		227192-02	WIRE ROPE ASSY. 102" WIDE RC-2B, RC-3B
		251588-02	WIRE ROPE ASSY. 96" WIDE RC-4B
		227190-02	WIRE ROPE ASSY. 102" WIDE RC-4B
		252402-02	WIRE ROPE ASSY. 96" WIDE RC-5B, RC-6B
		252403-02	WIRE ROPE ASSY. 102" WIDE RC-5B, RC-6B
		252401-02	WIRE ROPE ASSY. 96" WIDE RC-6K
		252400-02	WIRE ROPE ASSY. 102" WIDE RC-6K
4	7	253307	SHEAVE ASSY. W/BEARING RC-2B, RC-3B
		253308	SHEAVE ASSY. W/BEARING RC-4B
		253309	SHEAVE ASSY. W/BEARING RC-5B, RC-6B, RC-6K
4a	1	253108	SHEAVE, RC-2B, RC-3B
		253107	SHEAVE, RC-4B
		253106	SHEAVE, RC-5B, RC-6B, RC-6K
4b	1	801412	BEARING
5	1	202465	BOLT, CYLINDER ASSEMBLY, RC-2B, RC-3B, RC-4B
		203237	BOLT, CYLINDER ASSEMBLY, RC-5B, RC-6B, RC-6K
6	1	202466	BOLT, CYLINDER ASSEMBLY, RC-2B, RC-3B
		202978	BOLT, CYLINDER ASSEMBLY, RC-4B
		203236	BOLT, CYLINDER ASSEMBLY, RC-5B, RC-6B, RC-6K
7	2	202619	COVER, UPPER PULLY LH, RC-2B, RC-3B
		202927	COVER, UPPER PULLY LH, RC-4B
		203212	COVER, UPPER PULLY LH, RC-5B, RC-6B, RC-6K
8	2	202777	COVER, UPPER PULLY RH, RC-2B, RC-3B
		202928	COVER, UPPER PULLY RH, RC-4B
		203213	COVER, UPPER PULLY RH, RC-5B, RC-6B, RC-6K

## PARTS DRAWINGS (PAGE 2)

ITEM	QTY.	PART NO.	DESCRIPTION
9	2	250635	INTERNAL STOP, INNER PLATE
10	2	250634	INTERNAL STOP, OUTER PLATE
11	2	226969	EMERGENCY BRAKE
12	1	226889	SWITCH TOGGLE
13	2	250800	PIN WELDMENT, SAFETY LATCH
14	1	253111	CYLINDER, 3" x 28" RC-2B, RC-3B
		253109	CYLINDER, 3-1/2" x 28" RC-4B
		253110	CYLINDER, 4" x 28" RC-5B, RC-6B, RC-6K
17	1	226202	COVER, MAINFRAME 96" WIDE RC-2B, RC-3B, RC-4B
		226203	COVER, MAINFRAME 102" WIDE RC-2B, RC-3B, RC-4B
		226088	COVER, MAINFRAME 96" WIDE RC-5B, RC-6B, RC-6K
		226089	COVER, MAINFRAME 102" WIDE RC-5B, RC-6B, RC-6K
18	1	250993	DECAL, UP/DOWN OUTSIDE
19	1	250992	DECAL, UP/DOWN INSIDE
28	2	227195	LINK LUG, RUNNER
29	4	030064	BOLT, 5/8-18 UNF x 2" GRADE 5
32	4	030569	LOCKWASHER, 5/8"
34	1	202562	CYLINDER ANCHOR PLATE RC-2B, RC-3B
		202926	CYLINDER ANCHOR PLATE RC-4B
		203210	CYLINDER ANCHOR PLATE RC-5B, RC-6B, RC-6K
35	4	030041	BOLT, 3/8-24 UNF x 1-1/2" LG. GRADE 8
38	4	203853	NUT, 3/8-24 UNF SELF LOCKING
46	2	253460	WASHER, SPACER (RC-2B, RC-3B ONLY)
57	1	252425	ANCHOR PLATE, CYL. ROD END (RC-2B, RC-3B ONLY)
64	1	250916	ELECTRICAL SWITCH ASSEMBLY
65	1	253464	SEAL KIT, HYD. CYLINDER RC-2B, RC-3B
		253465	SEAL KIT, HYD. CYLINDER RC-4B
		253466	SEAL KIT, HYD. CYLINDER RC-5B, RC-6B, RC-6K
66	1	250876	SWITCH SEAL
74	3	253330	BOLT, 1/2-20 UNF x 2-3/4" LG.
75	2	253331	BOLT, 1/2-20 UNF x 3-5/8" LG.
76	1	253333	BOLT, 1/2-20 UNF x 4-3/4" LG.

# PARTS DRAWINGS (PAGE 3)

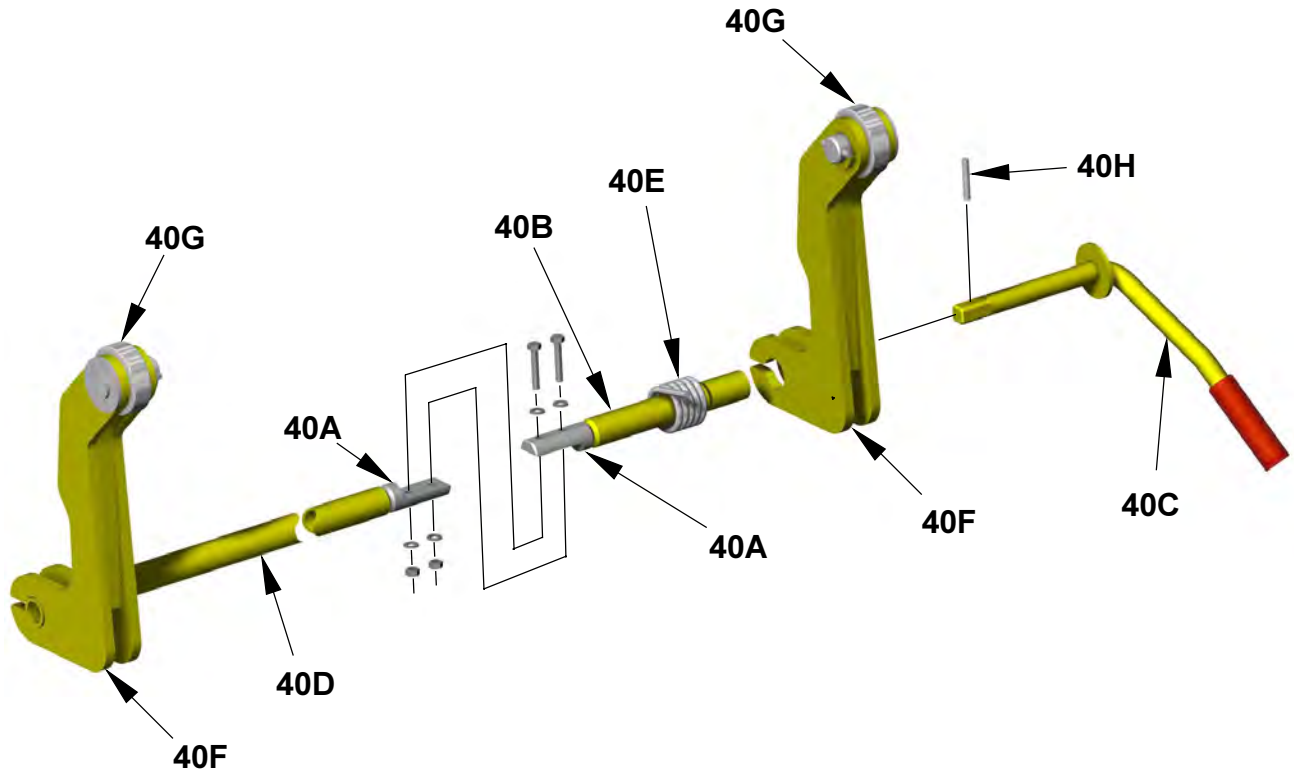

ITEM	QTY.	PART NUMBER		DESCRIPTION
40		262418		CAM FOLLOWER ASSY. 90" WIDE
			262419	CAM FOLLOWER ASSY. 96" WIDE
			262419-01	CAM FOLLOWER ASSY. 96" WIDE AB
			262420	CAM FOLLOWER ASSY. 102" WIDE
			262420-01	CAM FOLLOWER ASSY. 102" WIDE AB
40A	1	262268		COUPLING ASSEMBLY
40B	1	262267		TUBE ANCHOR WELDMENT
40C	1	262417		HANDLE WELDMENT, CAM FOLLOWER
40D	1		262270	CAM FOLLOWER SHAFT, 96" WIDE
			262270-01	CAM FOLLOWER SHAFT, 102" WIDE
		262270-02		CAM FOLLOWER SHAFT, 90" WIDE
40E	1	217643		TORSION SPRING
40F	2	251231		CAM WELDMENT
40G	2	250844		ROLLER ASSEMBLY
40H	1	030410		ROLL PIN, 1/4" x 1-1/2"

# PARTS DRAWINGS (PAGE 4)

**MAXON**<sup>®</sup> 11921 Slauson Ave. Santa Fe Springs, CA. 90670 (800) 227-4116 FAX (888) 771-7713

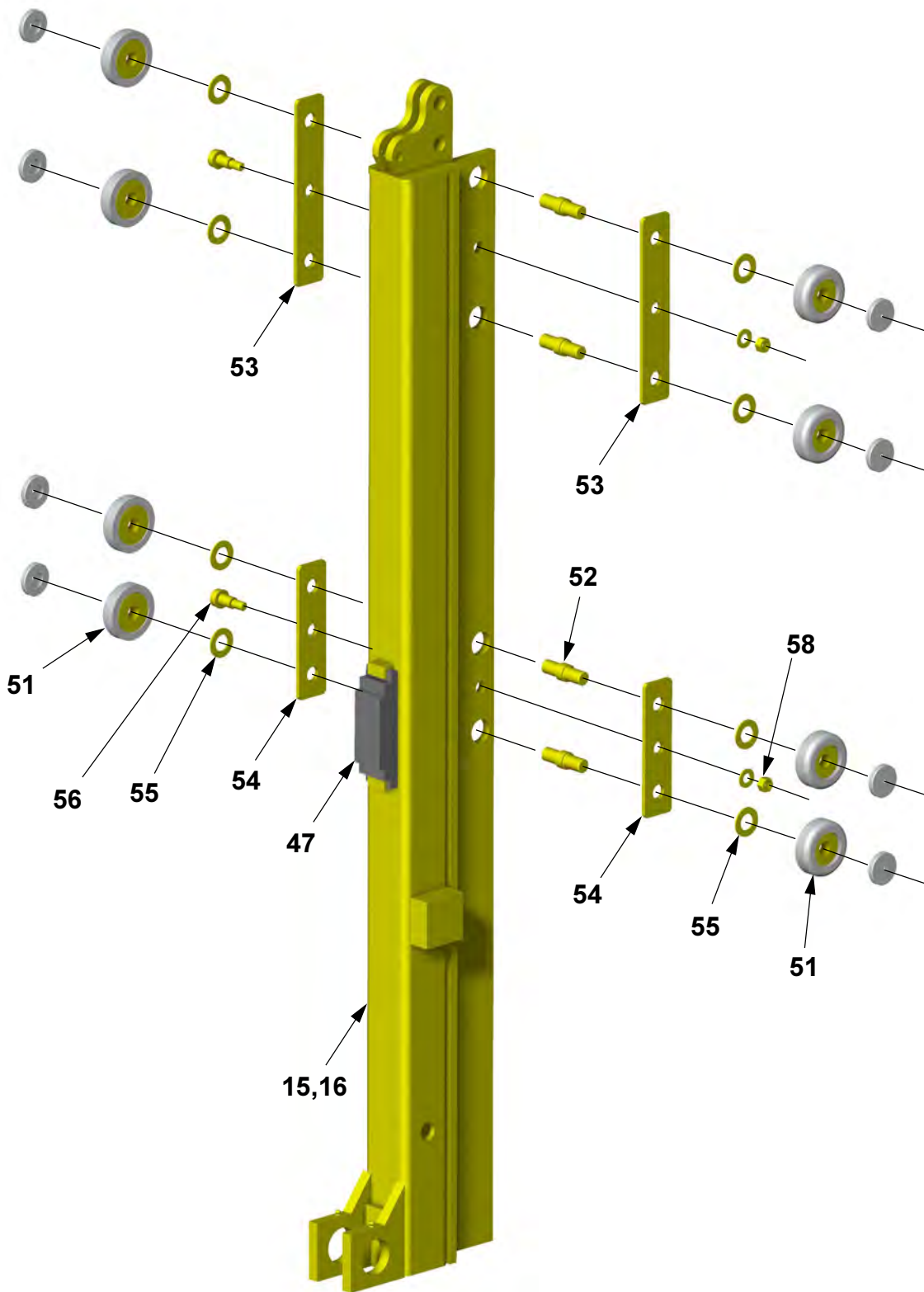

## PARTS DRAWINGS (PAGE 4)

ITEM	QTY.	PART NO.	DESCRIPTION
15	1	251037-01	RUNNER ASSEMBLY LH RC-2B, RC-3B
		251038-01	RUNNER ASSEMBLY LH RC-4B
		251039-01	RUNNER ASSEMBLY LH RC-5B, RC-6B
		251040-01	RUNNER ASSEMBLY LH RC-6K
16	1	251037-02	RUNNER ASSEMBLY RH RC-2B, RC-3B
		251038-02	RUNNER ASSEMBLY RH RC-4B
		251039-02	RUNNER ASSEMBLY RH RC-5B, RC-6B
		251040-02	RUNNER ASSEMBLY RH RC-6K
47	2	227426	RUBBER BUMPER
51	16	202800	ROLLER BEARING ASSEMBLY
52	8	202796	BALL RACE TANDEM SHAFT
53	4	203002	PLATE, TANDEM SUPPORT, 8" LG. TOP
54	4	227395	PLATE, TANDEM SUPPORT, 8" LG. BOTTOM
55	16	202771	FLAT WASHER
56	4	202797	SHOULDER BOLT

# EMERGENCY BRAKE DRAWING

## P/N 226969

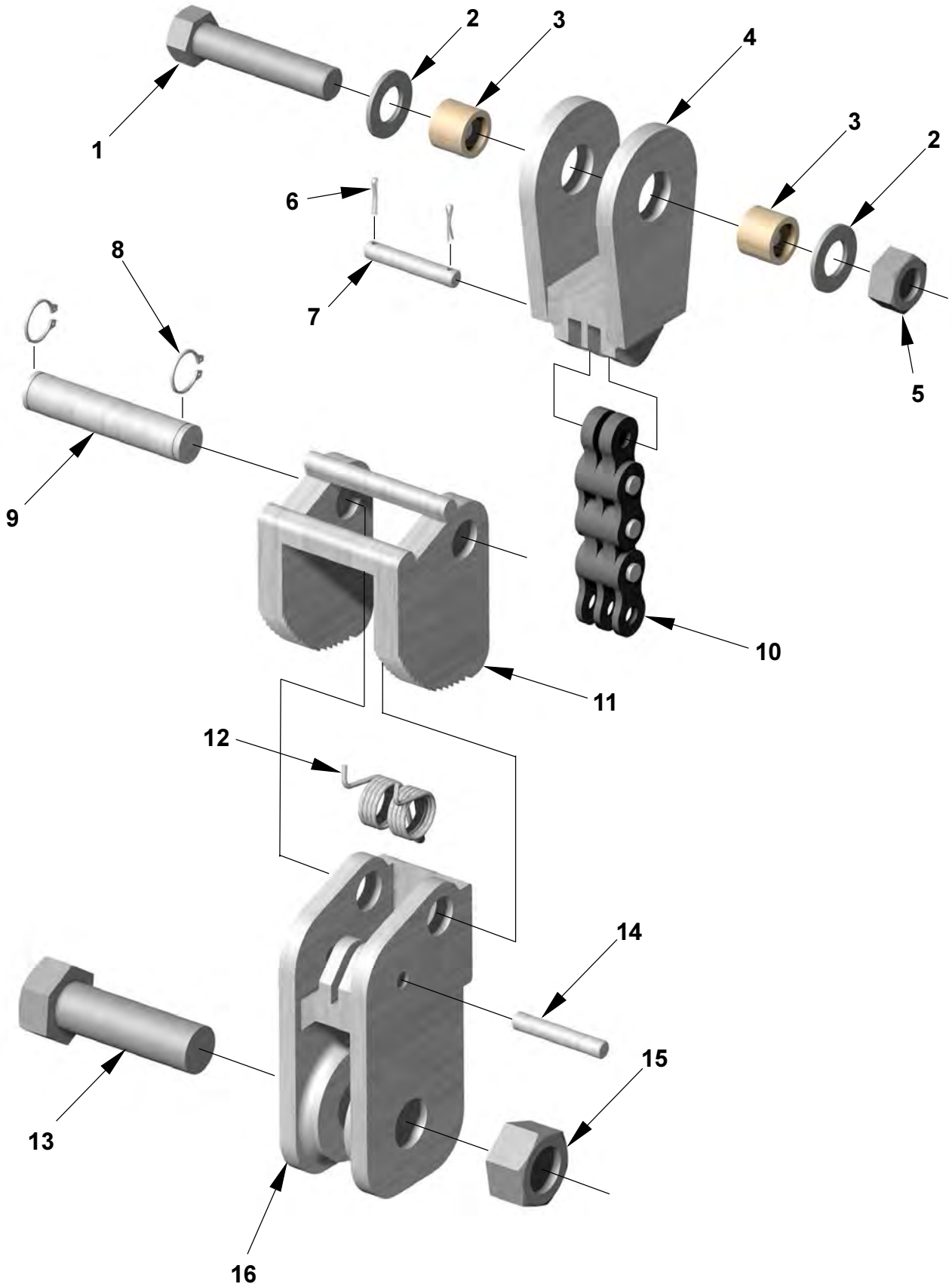

**MAXON**<sup>®</sup> 11921 Slauson Ave. Santa Fe Springs, CA. 90670 (800) 227-4116 FAX (888) 771-7713



## EMERGENCY BRAKE DRAWING P/N 226969

ITEM	QTY.		PART NUMBER	DESCRIPTION
	RC-2,3	RC-4,5,6		
1	1	N/A	227317	HEX BOLT, 7/16-20 UNF GRD.8 x 2"LG.
2	2		030585	WASHER, FLAT, 7/16"
3	2		227315	ROUND TUBE, 5/8" O.D. x .083W x 1/2" LG.
4	1		226984	BRACKET
5	1	N/A	227316	HEX NUT, 7/16-20 UNF ELASTIC STOP NUT
6	2		226855	COTTER PIN
7	1		226982	PIN, (LEAF CHAIN / BRACKET)
8	2		227008	RETAINING RING
9	1		226979	SHAFT (CAM PIVOT)
10	1		226981-01	LEAF CHAIN
11	1		226975	SNAIL CAM
12	1		226980	TORSION SPRING
13	1	2	030064	HEX BOLT, 5/8-18 UNF GRD.5 x 2"LG.
14	1		226978	PIN (ANCHOR PLATE / LEAF CHAIN)
15	1	2	226940	HEX NUT, 5/8-18 UNF ELASTIC STOP NUT
16	1		226970	ANCHOR PLATE

# PUMP, CAM CLOSER P/N 253171

**MAXON**® 11921 Slauson Ave. Santa Fe Springs, CA. 90670 (800) 227-4116 FAX (888) 771-7713

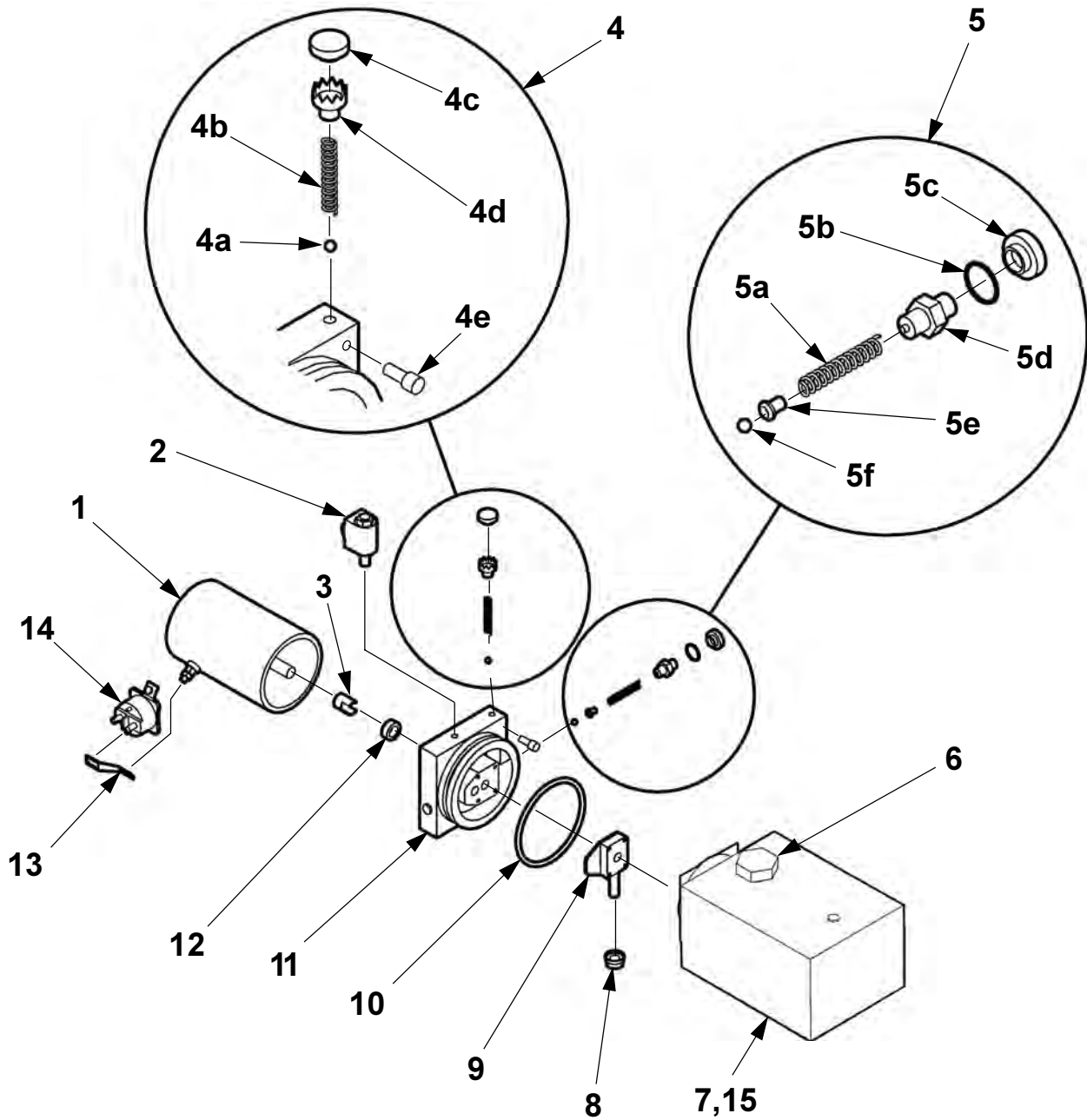

# PUMP, CAM CLOSER P/N 253171

ITEM	QTY.	PART NUMBER	DESCRIPTION
1	1	250093	MOTOR, HEAVY DUTY 12 VOLTS DC
2	1	253353	VALVE, SOLENOID 2-WAY
*2a	1	226594	O-RING KIT, 2-WAY VALVE
3	1	229200	COUPLING
4	1	251885	CHECK VALVE KIT
4a	1	260257	STEEL BALL
4b	1	260254	SPRING
4c	1	260258	PLUG
4d	1	260255	RETAINER
4e	1	260256	SOCKET HEAD CAPSCREW
5	1	260229	RELIEF VALVE KIT
5a	1	260231	SPRING
5b	1	260235	O-RING
5c	1	260234	VALVE CAP
5d	1	260232	ADJUSTING SCREW
5e	1	260233	SPRING GUIDE
5f	1	260230	STEEL BALL
6	1	260847	FILLER/BREATHER CAP
7	1	251882	RESERVOIR, 3 QT.
8	1	260250	FILTER
9	1	260236	PUMP ASSEMBLY
10	1	251884	O-RING
11	1	260252	DRIVEPLATE ASSEMBLY 5"
12	1	260261	OIL SEAL
13	1	262966	BUS BAR
14	1	262939	SOLENOID SWITCH
*15	4	229202	CAPSCREW, HEX. WASHER HD.

**MAXON**<sup>®</sup> 11921 Slauson Ave. Santa Fe Springs, CA. 90670 (800) 227-4116 FAX (888) 771-7713

# PUMP, HYDRAULIC CLOSER

## P/N 262256

**MAXON**<sup>®</sup>

11921 Slauson Ave. Santa Fe Springs, CA. 90670 (800) 227-4116 FAX (888) 771-7713

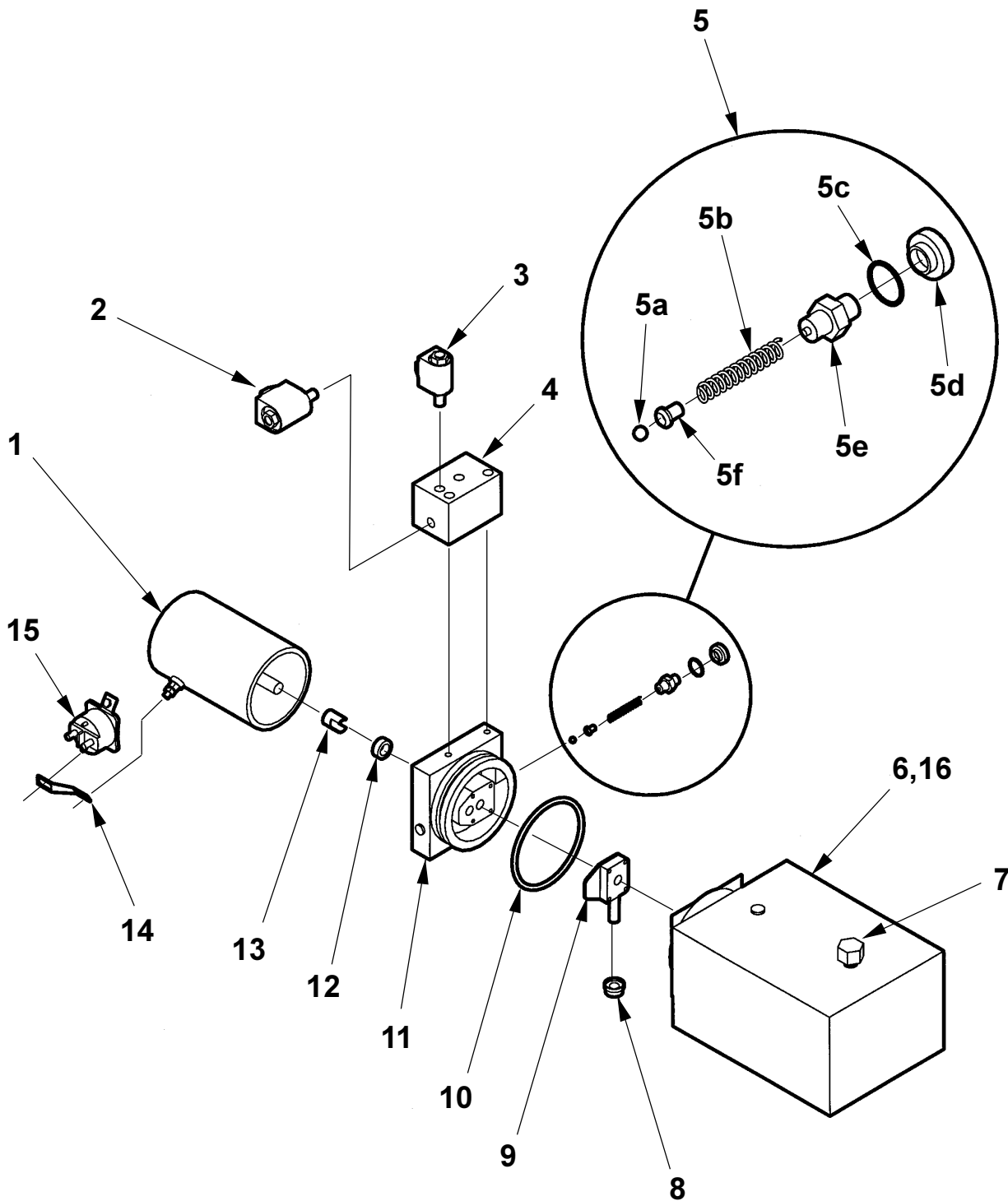

**PUMP, HYDRAULIC CLOSER  
P/N 262256**

ITEM	QTY.	PART NO.	DESCRIPTION
1	1	250093	HEAVY DUTY MOTOR, 12 VDC
2	1	260276	VALVE, SOLENOID 4-WAY
*2a	1	226595	O-RING KIT, 4-WAY VALVE
3	1	253353	VALVE, SOLENOID 2-WAY
*3a	1	226594	O-RING KIT, 2-WAY VALVE
4	1	260275	MANIFOLD BLOCK ASSEMBLY
5	1	260229	RELIEF VALVE KIT
5a	1	260230	STEEL BALL
5b	1	260231	SPRING
5c	1	260235	O-RING
5d	1	260234	VALVE CAP
5e	1	260232	ADJUSTING SCREW
5f	1	260233	SPRING GUIDE
6	1	261106	RESERVOIR, 2.5 GAL. W/.75 BREATHER
7	1	260847	FILLER/BREATHER CAP
8	1	260250	FILTER
9	1	260236	PUMP ASSEMBLY
10	1	251884	O-RING
11	1	260274	DRIVEPLATE ASSEMBLY, 5"
12	1	260261	OIL SEAL
13	1	229200	COUPLING
14	1	262966	BUS BAR
15	1	262939	SOLENOID SWITCH
*16	4	229202	CAPSCREW, HEX HD. WASHER

**MAXON**<sup>®</sup> 11921 Slauson Ave. Santa Fe Springs, CA. 90670 (800) 227-4116 FAX (888) 771-7713

# FOLDING PLATFORM VARIATIONS

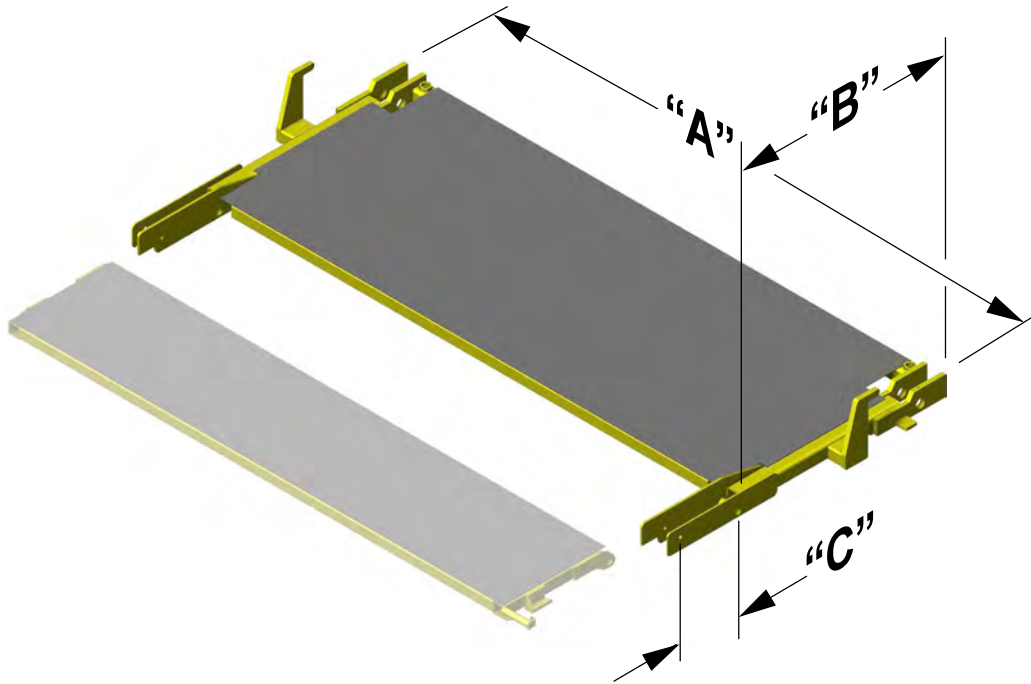

## RC-2B, RC-3B, RC-4B

MODEL	96" WIDE VEHICLE	96" WIDE VEHICLE (W/36" + F/S)	96" WIDE VEHICLE	96" WIDE VEHICLE (W/36" + F/S)
PART NO.	229330-01	229330-02	229330-03	229330-04
DIM. "A"	95-3/8"			
DIM. "B"	36"		42"	
DIM. "C"	10"	14"	10"	14"
MODEL	102" WIDE VEHICLE	102" WIDE VEHICLE (W/36" + F/S)	102" WIDE VEHICLE	102" WIDE VEHICLE (W/36" + F/S)
PART NO.	229330-05	229330-06	229330-07	229330-08
DIM. "A"	101-3/8"			
DIM. "B"	36"		42"	
DIM. "C"	10"	14"	10"	14"
MODEL	90" WIDE VEHICLE	90" WIDE VEHICLE (W/36" + F/S)	90" WIDE VEHICLE	90" WIDE VEHICLE (W/36" + F/S)
PART NO.	229330-09	229330-10	229330-11	229330-12
DIM. "A"	88-5/8"			
DIM. "B"	36"		42"	
DIM. "C"	10"	14"	10"	14"

## RC-5B, RC-6B, RC-6K

MODEL	96" WIDE VEHICLE	96" WIDE VEHICLE (W/36" + F/S)	96" WIDE VEHICLE	96" WIDE VEHICLE (W/36" + F/S)
PART NO.	229331-01	229331-02	229331-03	229331-04
DIM. "A"	95-3/8"			
DIM. "B"	36"		42"	
DIM. "C"	10"	14"	10"	14"
MODEL	102" WIDE VEHICLE	102" WIDE VEHICLE (W/36" + F/S)	102" WIDE VEHICLE	102" WIDE VEHICLE (W/36" + F/S)
PART NO.	229331-05	229331-06	229331-07	229331-08
DIM. "A"	101-3/8"			
DIM. "B"	36"		42"	
DIM. "C"	10"	14"	10"	14"
MODEL	90" WIDE VEHICLE	90" WIDE VEHICLE (W/36" + F/S)	90" WIDE VEHICLE	90" WIDE VEHICLE (W/36" + F/S)
PART NO.	229331-09	229331-10	229331-11	229331-12
DIM. "A"	88-5/8"			
DIM. "B"	36"		42"	
DIM. "C"	10"	14"	10"	14"

**MAXON**<sup>®</sup>

11921 Slauson Ave. Santa Fe Springs, CA. 90670 (800) 227-4116 FAX (888) 771-7713

# FOLD OVER SECTION VARIATIONS

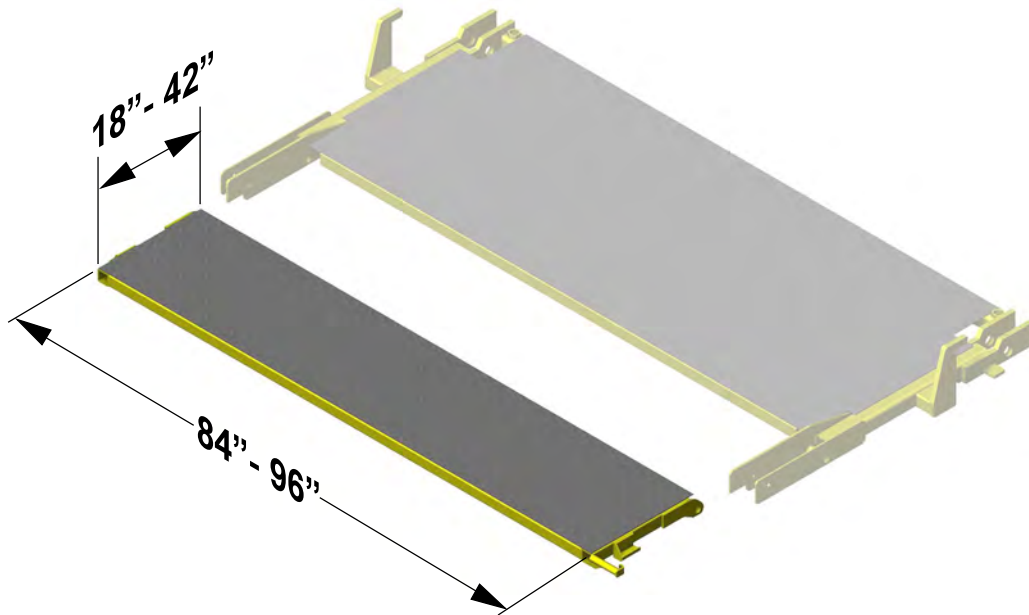

## RC-2B, RC-3B, RC-4B

96" WIDE VEHICLE		102" WIDE VEHICLE		90" WIDE VEHICLE	
FOLDOVER SIZE	PART NO.	FOLDOVER SIZE	PART NO.	FOLDOVER SIZE	PART NO.
90" x 18"	229334-01	96" x 18"	229334-06	84" x 18"	229334-11
90" x 24"	229334-02	96" x 24"	229334-07	84" x 24"	229334-12
90" x 30"	229334-03	96" x 30"	229334-08	84" x 30"	229334-13
90" x 36"	229334-04	96" x 36"	229334-09	84" x 36"	229334-14
90" x 42"	229334-05	96" x 42"	229334-10	84" x 42"	229334-15

## RC-5B, RC-6B, RC-6K

96" WIDE VEHICLE		102" WIDE VEHICLE		90" WIDE VEHICLE	
FOLDOVER SIZE	PART NO.	FOLDOVER SIZE	PART NO.	FOLDOVER SIZE	PART NO.
90" x 18"	229335-01	96" x 18"	229335-06	84" x 18"	229335-11
90" x 24"	229335-02	96" x 24"	229335-07	84" x 24"	229335-12
90" x 30"	229335-03	96" x 30"	229335-08	84" x 30"	229335-13
90" x 36"	229335-04	96" x 36"	229335-09	84" x 36"	229335-14
90" x 42"	229335-05	96" x 42"	229335-10	84" x 42"	229335-15

# ONE-PIECE PLATFORM VARIATIONS (CAM TYPE)

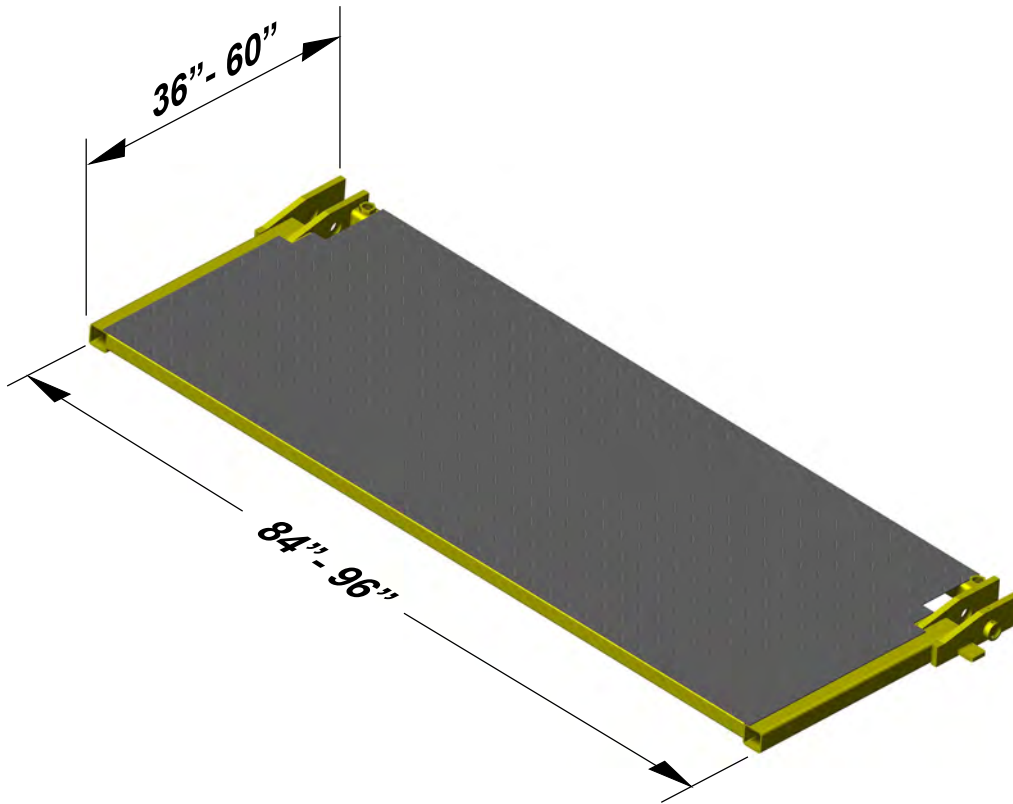

**MAXON**<sup>®</sup>

11921 Slauson Ave. Santa Fe Springs, CA. 90670 (800) 227-4116 FAX (888) 771-7713

96" WIDE VEHICLE		102" WIDE VEHICLE		90" WIDE VEHICLE	
PLATFORM SIZE	PART NO.	PLATFORM SIZE	PART NO.	PLATFORM SIZE	PART NO.
90" x 36"	229336-01	96" x 36"	229336-05	84" x 36"	229336-09
90" x 42"	229336-02	96" x 42"	229336-06	84" x 42"	229336-10
90" x 48"	229336-03	96" x 48"	229336-07	84" x 48"	229336-11
90" x 60"	229336-04	96" x 60"	229336-08	84" x 60"	229336-12



# RC/RCT HYDRAULIC CLOSER COMPONENTS

ALL OTHER PARTS NOT SHOWN ARE  
STANDARD RC COMPONENTS

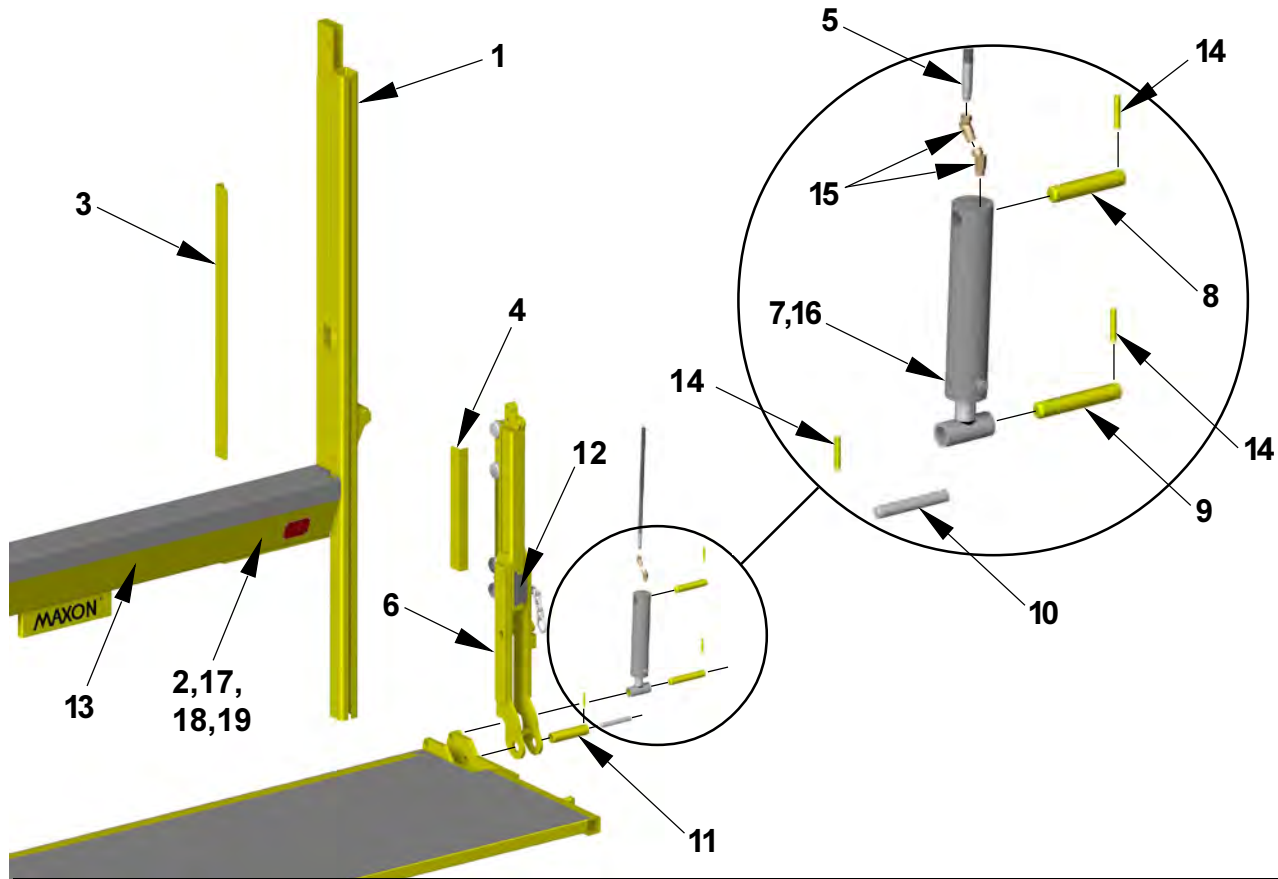

ITEM	QTY.	PART NO.	DESCRIPTION
1	1	250912-01	MAIN FRAME COLUMN ASSEMBLY 96" WIDE RC-2B, RC-3B
		250912-06	MAIN FRAME COLUMN ASSEMBLY 102" WIDE RC-2B, RC-3B
		250914-01	MAIN FRAME COLUMN ASSEMBLY 96" WIDE RC-4B
		250914-05	MAIN FRAME COLUMN ASSEMBLY 102" WIDE RC-4B
		250908-01	MAIN FRAME COLUMN ASSEMBLY 96" WIDE RC-5B, RC-6B
		250908-05	MAIN FRAME COLUMN ASSEMBLY 102" WIDE RC-5B, RC-6B
2	1	253038	CHANNEL REMOTE CONTROL
3	1	227369	GUIDE, HOSE, MAINFRAME
4	1	227370-01	GUIDE, HOSE, RUNNER RC-2B, RC-3B
		227370-02	GUIDE, HOSE, RUNNER RC-4B
		227370-03	GUIDE, HOSE, RUNNER RC-5B, RC-6B

LIST CONTINUES ON NEXT PAGE

## RC/RCT HYDRAULIC CLOSER COMPONENTS

ITEM	QTY.	PART NO.	DESCRIPTION
5	1	800235-32	HOSE ASSEMBLY, 120" LONG
6	1	227334	RUNNER ASSEMBLY, RIGHT SIDE RC-2B, RC-3B
		227339	RUNNER ASSEMBLY, RIGHT SIDE RC-4B
		227342	RUNNER ASSEMBLY, RIGHT SIDE RC-5B, RC-6B
7	1	222214	CYLINDER, 2" X 8"
8	1	073505	PIN, CYLINDER, UPPER, 5-1/4" LONG
9	2	070165	PIN, CYLINDER, LOWER, 6" LONG
10	1	221905-01	PIN, 5-1/8" LONG
11	1	222328	PIN, HINGE, 6" LONG
12	1	227664	RUBBER BUMPER
13	1	226201	COVER, MAINFRAME 96" WIDE RC-2B, RC-3B, RC-4B
		226200	COVER, MAINFRAME 102" WIDE RC-2B, RC-3B, RC-4B
		226458	COVER, MAINFRAME 96" WIDE RC-5B, RC-6B
		226460	COVER, MAINFRAME 102" WIDE RC-5B, RC-6B
14	5	221416	ROLL PIN, 3/8" X 2" LONG
15	2	227381	SWIVEL ELBOW, 45, 1/4" F X 1/4" M
16	1	226568	SEAL KIT, HYDRAULIC CYLINDER, 2 X 8
17	1	250878	SWITCH MOUNTING PLATE
18	1	250994	DECAL P/F CLOSER
19	2	252427	ELECT. SWITCH & HARNESS
20	1	253038	CHANNEL REMOTE CONTROL

**MAXON**<sup>®</sup>

11921 Slauson Ave. Santa Fe Springs, CA. 90670 (800) 227-4116 FAX (888) 771-7713