

INSTRUCTION, GPTLR GRAVITY DOWN HAND PUMP KIT

GPTLR KIT P/N 283331-01

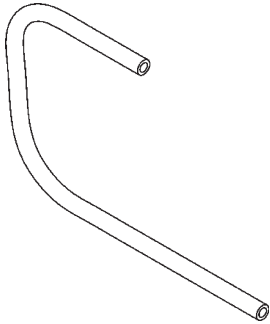

HOSE, 3/8" X 25" LG
P/N 251855-06
QTY. 1

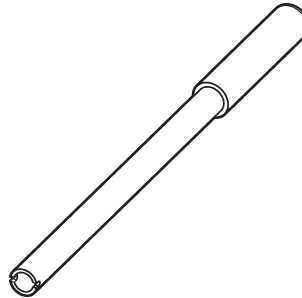

HANDLE ASSEMBLY
P/N 251407-02
QTY. 1

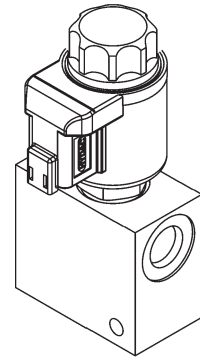

LOCK VALVE
P/N 283333-03
QTY. 1



HAND PUMP BRACKET
P/N 281461-01
QTY. 1



TUBE ASSEMBLY
P/N 281287-01
QTY. 1

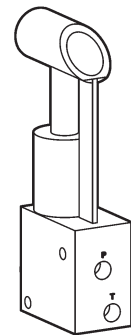

HAND PUMP
P/N 266588-01
QTY. 1

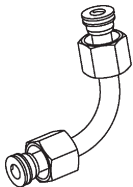

TUBE ASSY
P/N 281284-01
QTY. 1

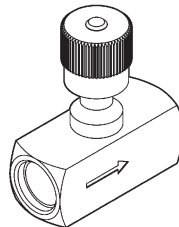

NEEDLE VALVE
P/N 906739-01
QTY. 1

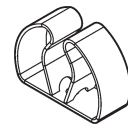

SPRING CLIP HOLDER
P/N 227681
QTY. 2



BLIND RIVET
P/N 207644-01
QTY. 2

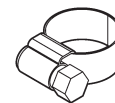

HOSE CLAMP SCREW
P/N 251854
QTY. 2



CONNECTOR #6FS #4 O-RING M-M
P/N 906759-01
QTY. 1



ADAPTER, 1/4 O-RING (M) TO 1/4" NPT
P/N 906756-01
QTY. 1



ADAPTER
P/N 228012
QTY. 1

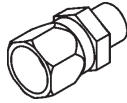

FITTING #6M
P/N 906751-01
QTY. 1



SOCKET SCREW, 1/4-20 X 1-3/4" LG.
P/N 900025-7
QTY. 2

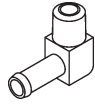

ELBOW, 90 DEG 1/4M - 3/8
P/N 251853
QTY. 2



TEE, ORFS SAE#6 O-R M/SW F
P/N 906750-01
QTY. 1



ELBOW
P/N 906707-01
QTY. 2

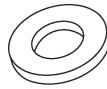

FLAT WASHER, 5/16"
P/N 902000-8
QTY. 4

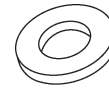

FLAT WASHER, 1/4"
P/N 902000-1
QTY. 2

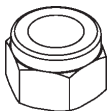

LOCK NUT, 5/16"-18
P/N 901001
QTY. 2



CAP SCREW, 5/16"-18 X 1" LG.
P/N 900009-2
QTY. 2



HEX NUT, 1/4"-20, THIN HEAD
P/N 901016-2
QTY. 2

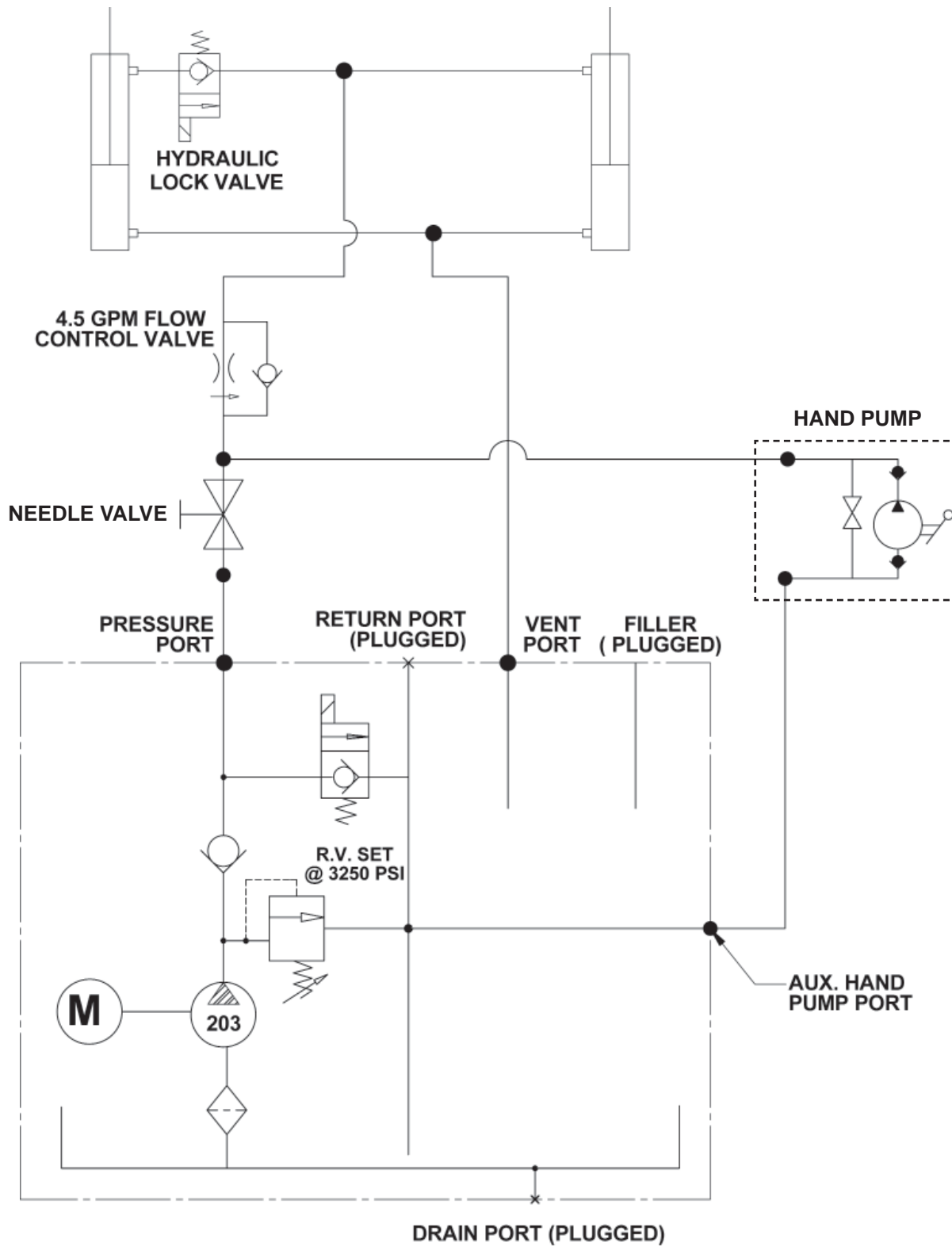

**GPTLR GRAVITY DOWN HAND PUMP HYDRAULIC SCHEMATIC
FIG. 3-1**

1. Lower the platform to a comfortable work height (**FIG. 4-1**). Then, place jack under the ICC bumper to support the platform (**FIG. 4-1**). Refer to **Operation Manual** for detailed operating instructions.

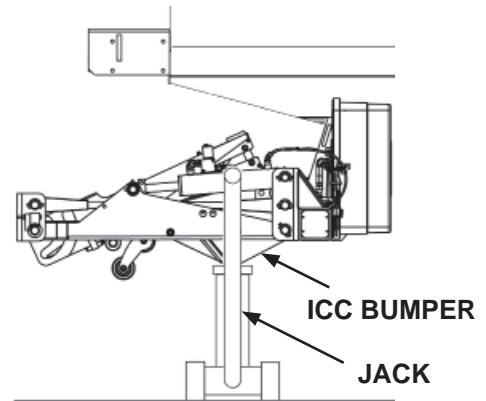

**SUPPORTING PLATFORM WITH JACK
(GPTLR-25/-33 SHOWN)
FIG. 4-1**

⚠ WARNING

To prevent accidental personal injury and equipment damage, make sure power is disconnected from Liftgate while installing parts.

2. Disconnect power from pump box by removing nut from negative (-) battery terminal and disconnect negative (-) battery cable (**FIG. 4-2**). Reinstall nut on negative (-) battery terminal.

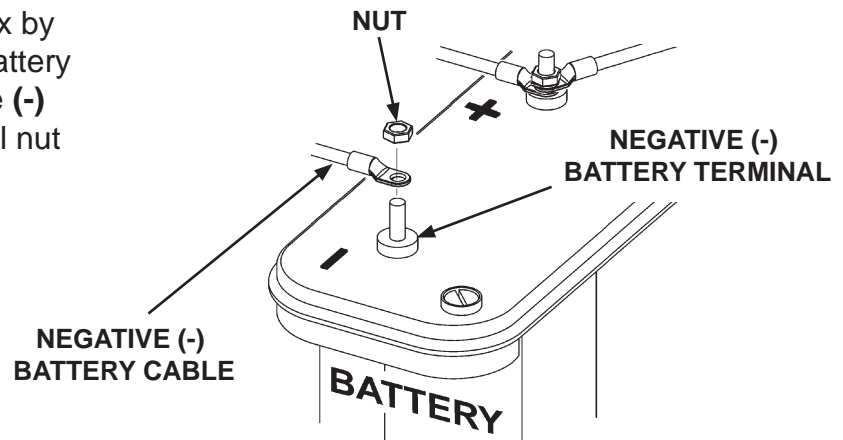

**DISCONNECTING POWER
FIG. 4-2**

3. Unfasten and remove the pump cover as shown in **FIG. 5-1**.

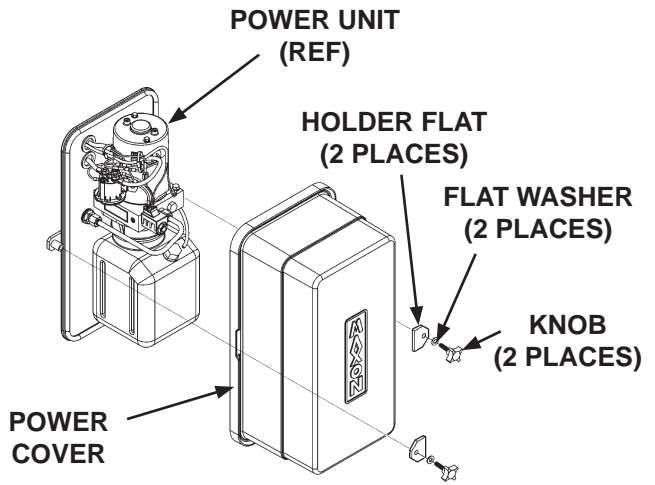

**UNFASTENING PUMP COVER
FIG. 5-1**

4. Measure and mark holes, on pump mounting plate, for hand pump bracket and for the spring clip brackets as shown in **FIG. 6-1**.
5. Drill 2 $\frac{11}{32}$ " holes on mount plate for the spring clip brackets and 2 $\frac{3}{16}$ " holes for hand pump bracket as shown in **FIG. 6-1**.

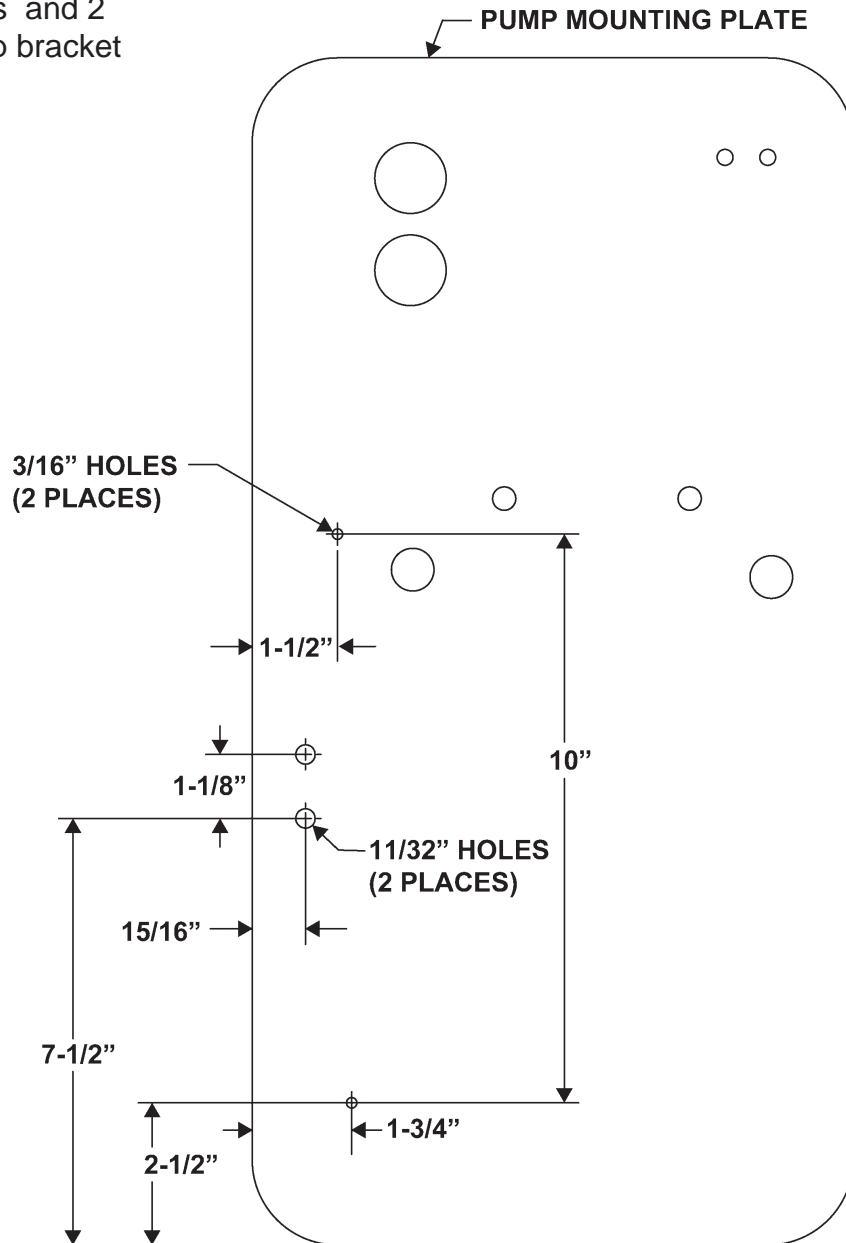

**MEASURING AND MARKING HOLES
FIG. 6-1**

6. Bolt hand pump bracket (Kit item) to the mounting plate (**FIG. 7-1**). Next, rivet spring clips to mounting plate. Then, bolt hand pump (Kit item) to bracket (**FIG. 7-2**).

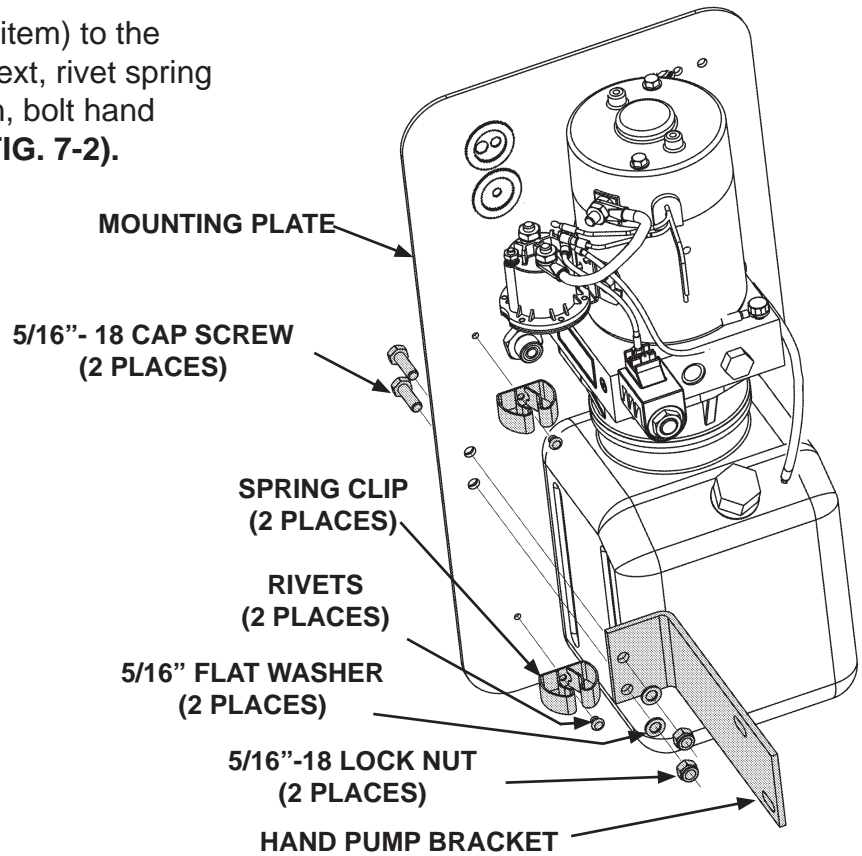

**BOLT HAND PUMP BRACKET TO MOUNTING PLATE
FIG. 7-1**

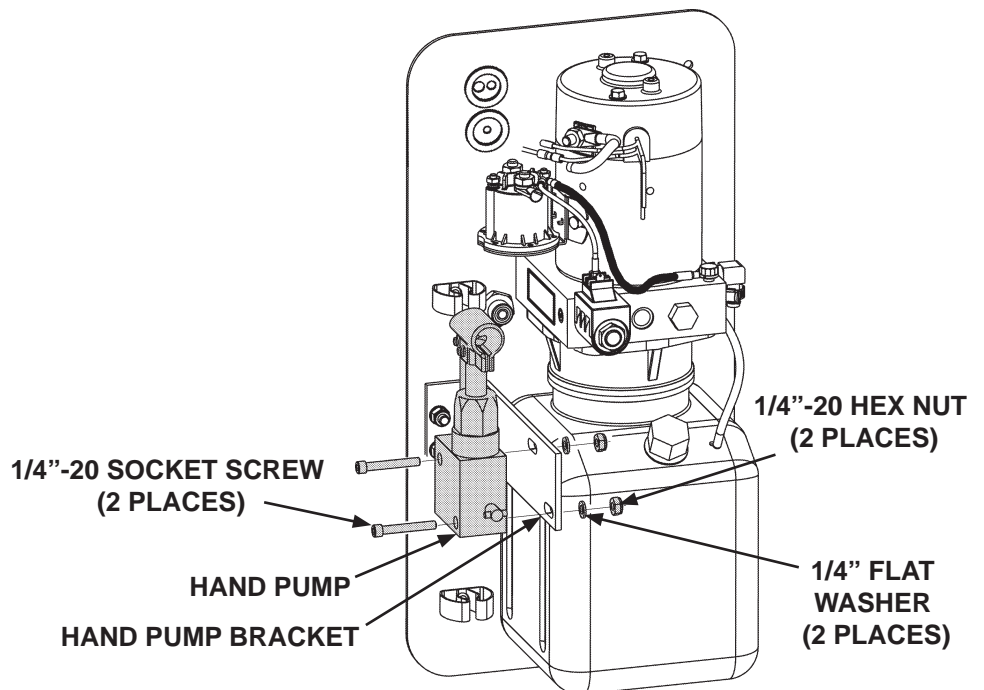

**BOLT HAND PUMP TO HAND PUMP BRACKET
FIG. 7-2**

CAUTION

Keep dirt, water and other contaminants from entering the hydraulic system. Before opening the hydraulic fluid reservoir filler cap, drain plug and hydraulic lines, clean up contaminants that can get in the openings. Also, protect the openings from accidental contamination.

7. Place a 5 gallon bucket under the pump to catch fluid. Remove pressure line and plug as shown in **FIG. 8-1**.

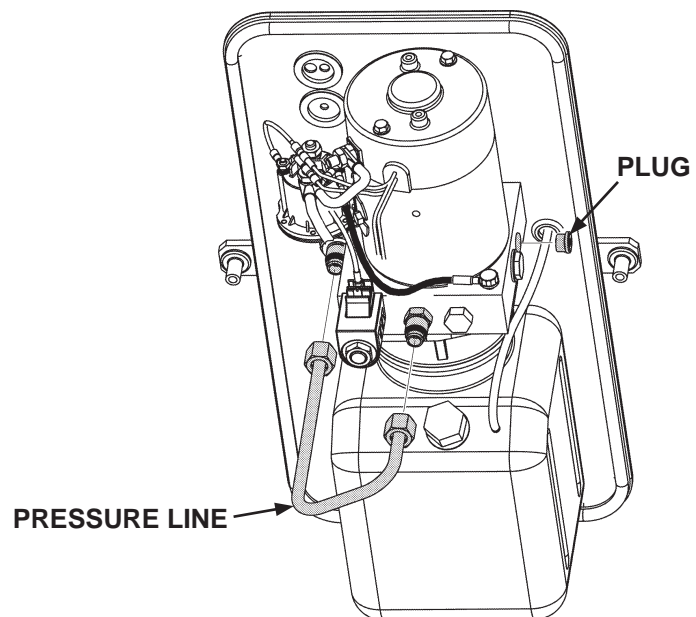

DISCONNECTING PRESSURE LINE & REMOVING PLUG
FIG. 8-1

NOTE: Position the needle valve so the arrow points to the elbow fitting. The hand pump will not work if the needle valve is reversed.

8. Connect the hand pump hydraulic lines, needle valve, and fittings (Kit items) (**FIG. 9-1**). First, install elbows and adapters in correct position on hand pump and manifold. Next, connect tees, fittings and hoses hand-tight. Then, position and tighten all connections and hose clamps securely.

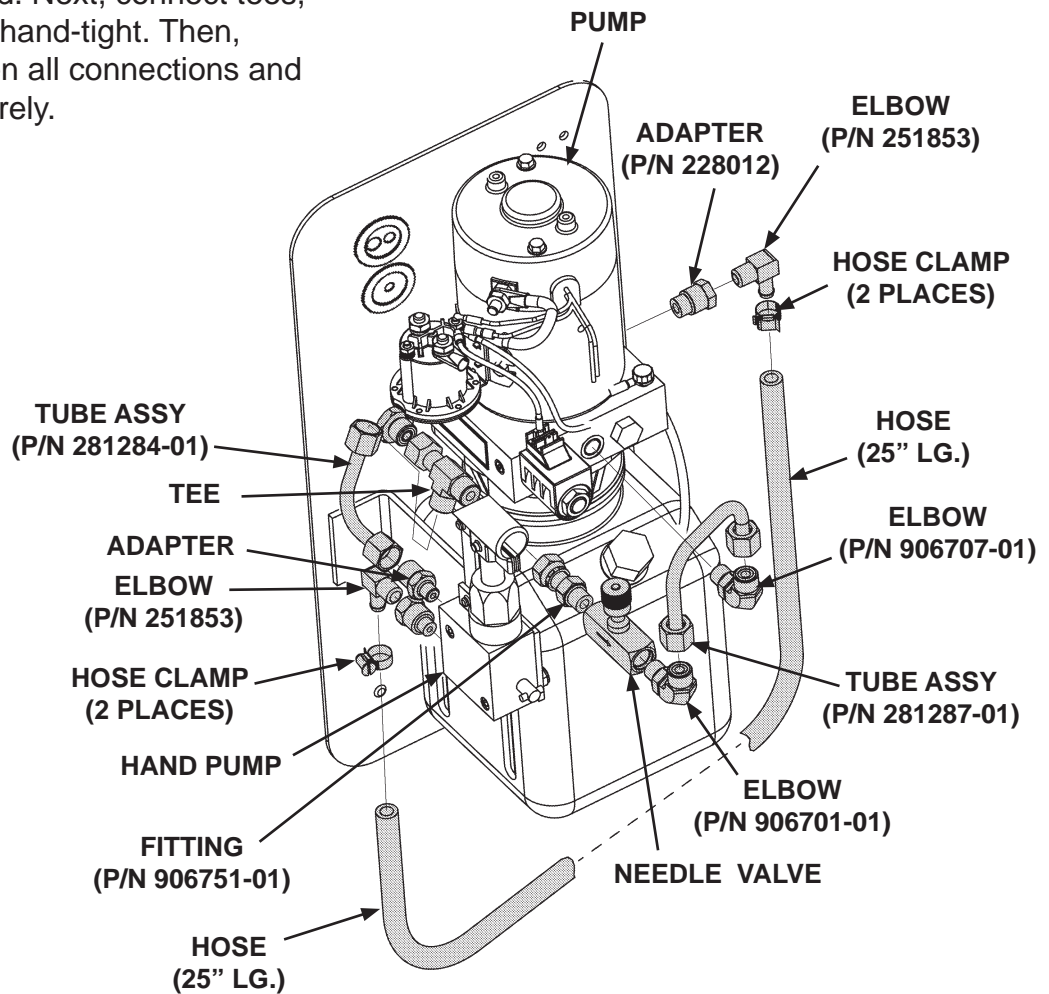

**CONNECTING HAND PUMP COMPONENTS
FIG. 9-1**

9. Remove original lock valve from RH lift cylinder and hose assembly (FIG. 10-1).

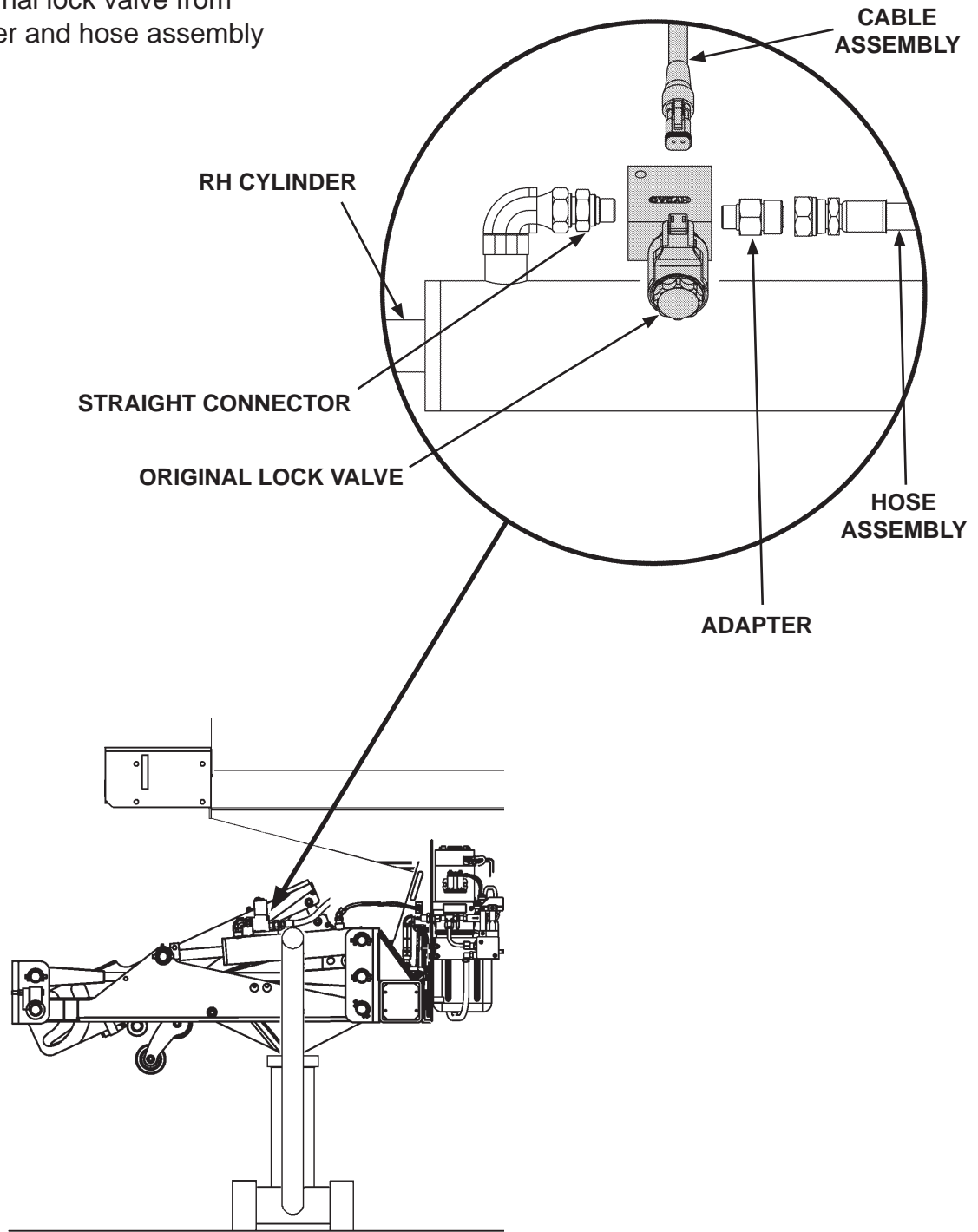

REMOVING LOCK VALVE
FIG. 10-1

10. Install lock valve with override (Kit item) on RH lift cylinder (**FIG. 11-1**).

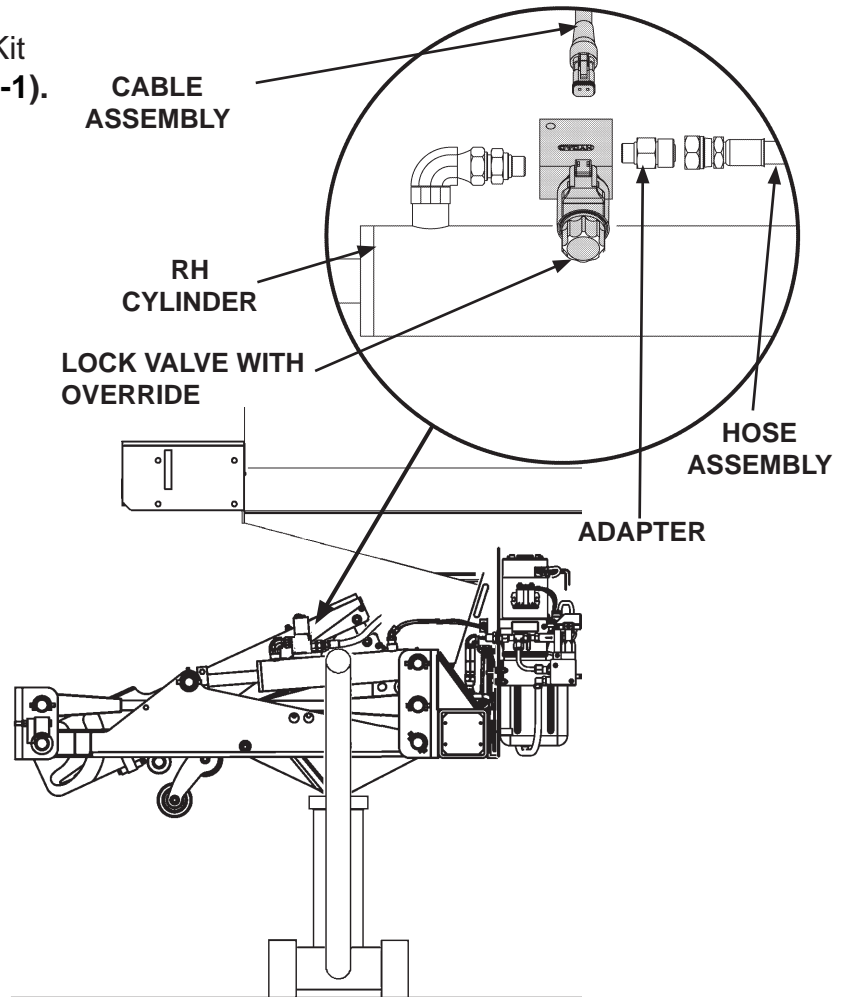

INSTALLING LOCK VALVE WITH OVERRIDE
FIG. 11-1

NOTE: If 1/8" thick shim stock is available, it can be used to set 1/8" clearance between lock valve coil and cylinder. The shim must be removed after tightening the lock valve in position.

11. Position lock valve with 1/8" clearance from cylinder (**FIG. 11-2**). Tighten fittings and hose connections (**FIG. 11-1**).

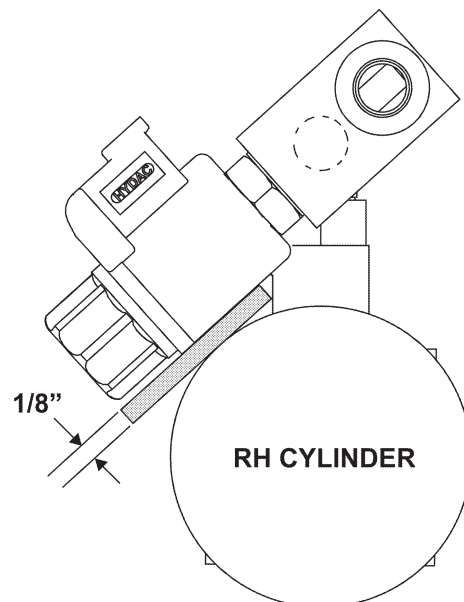

POSITIONING LOCK VALVE WITH CLEARANCE
FIG. 11-2

NOTE: Ensure pressure release valve is closed on the hand pump (turn clockwise) before raising platform.

12. Close needle valve by turning knob fully clockwise (**FIG. 12-1**). Then, close hand pump release valve, by turning valve clockwise with handle.

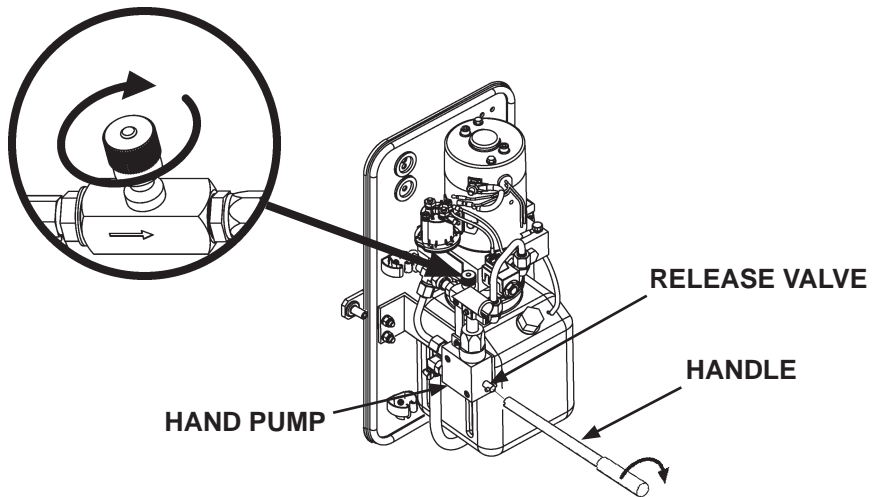

**CLOSING NEEDLE VALVE & HAND PUMP
RELEASE VALVE
FIG. 12-1**

NOTE: Allow coil to hang from cable assembly until lock valve is reset (locked).

13. Remove plastic nut and slide coil from lock valve on RH cylinder. (FIG. 13-1).

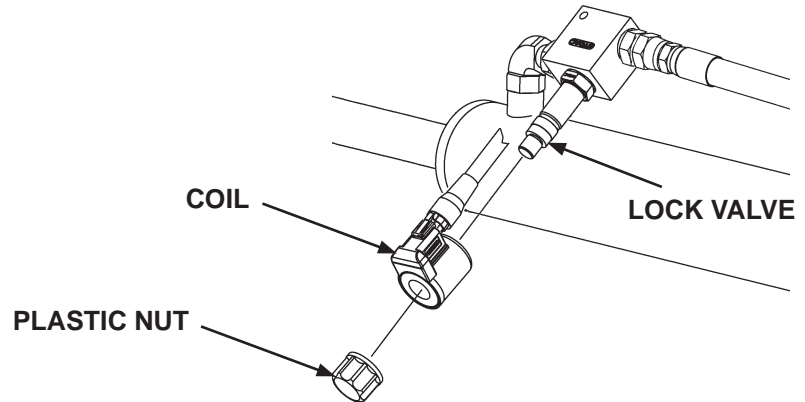

REMOVING NUT & COIL FROM LOCK VALVE
FIG. 13-1

14. Ensure valve is closed to locked (reset) position by turning shaft fully clockwise (FIG. 13-2).

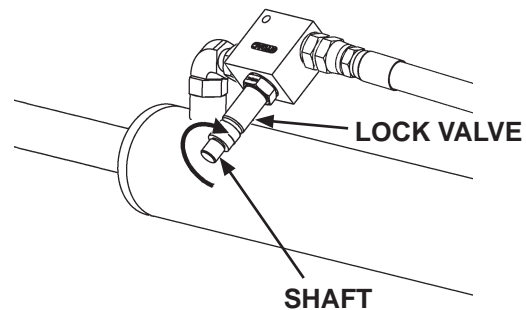

ENSURING LOCK VALVE IS CLOSED
FIG. 13-2

15. Lower and remove floor jack (**FIG. 14-1**).

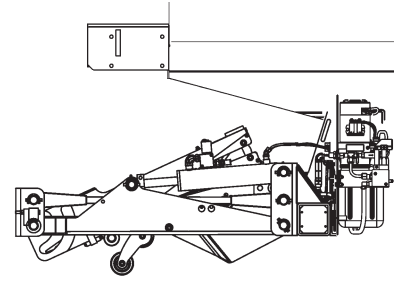

JACK REMOVED
FIG. 14-1

16. Override (open) lock valve
by turning shaft fully counterclockwise
(**FIG. 14-2**).

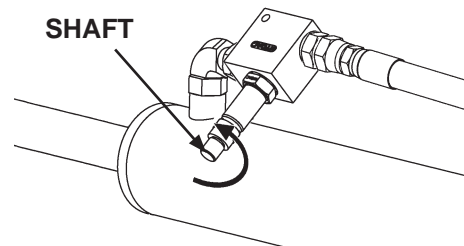

OVERRIDING LOCK VALVE
FIG. 14-2

17. Lower platform 1/2 the distance to ground (**FIG. 15-1**) by turning hand pump release valve counterclockwise with handle (**FIG. 15-2**). Turn release valve clockwise to stop platform from lowering (**FIG. 15-2**).

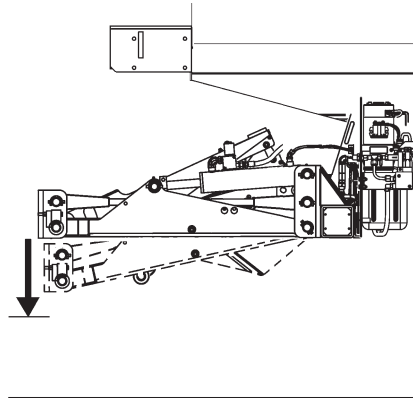

LOWERING PLATFORM WITH HAND PUMP
FIG. 15-1

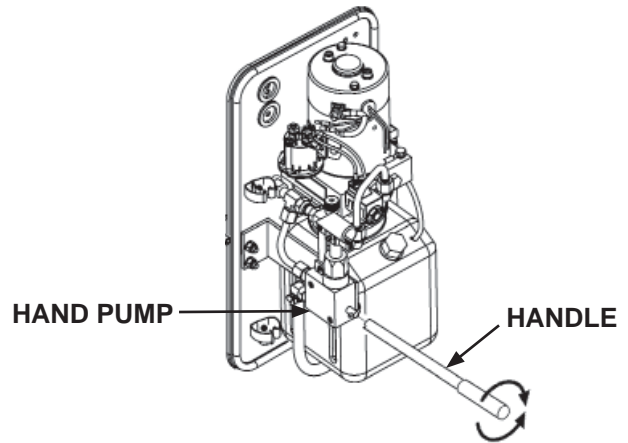

OPENING/CLOSING RELEASE VALVE
FIG. 15-2

18. Reset (close) the lock valve by turning shaft fully clockwise, (**FIG. 16-1**) so that it locks.

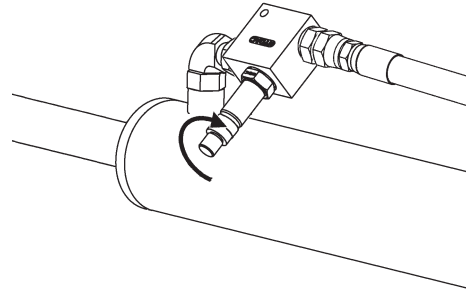

**RESETTING (CLOSE) LOCK VALVE
FIG. 16-1**

19. Reinstall coil and plastic nut (**FIG. 16-2**).

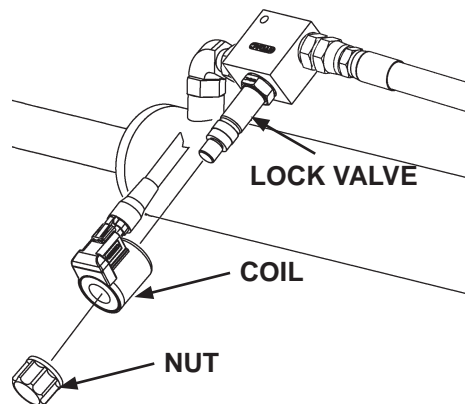

**REINSTALLING COIL AND PLASTIC NUT
FIG. 16-2**

20. Reconnect the negative (-) battery cable to the negative (-) battery terminal (FIG. 17-1). Tighten nut.

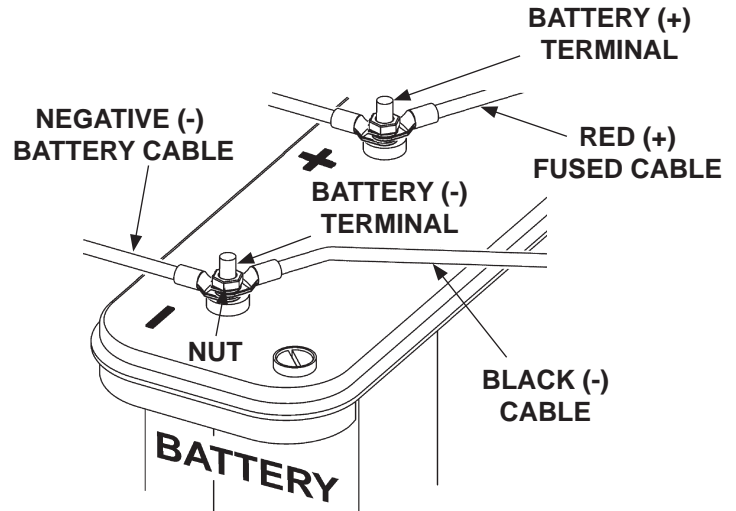

RECONNECTING POWER
FIG. 17-1

CAUTION

The hand pump is only intended for stowing the platform if the power unit does not work. Do not use for repeated loading and unloading of vehicle.

21. Open the needle valve by turning knob fully counterclockwise (FIG. 17-2).

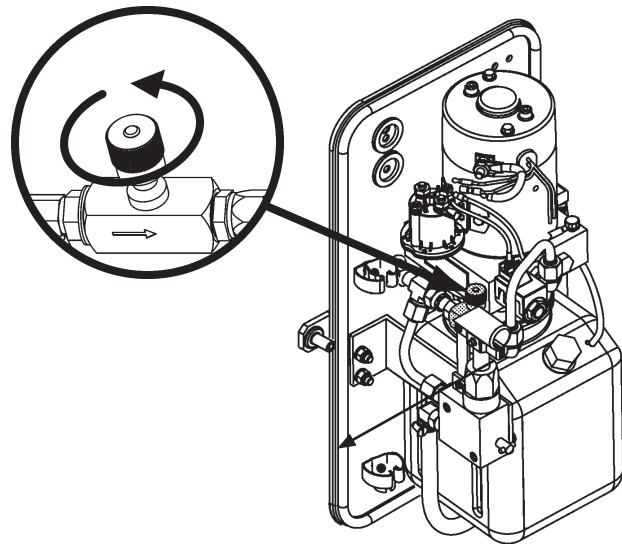

OPENING NEEDLE VALVE
FIG. 17-2

22. Use the control switch to **LOWER** platform to the ground (**FIG. 18-1**).

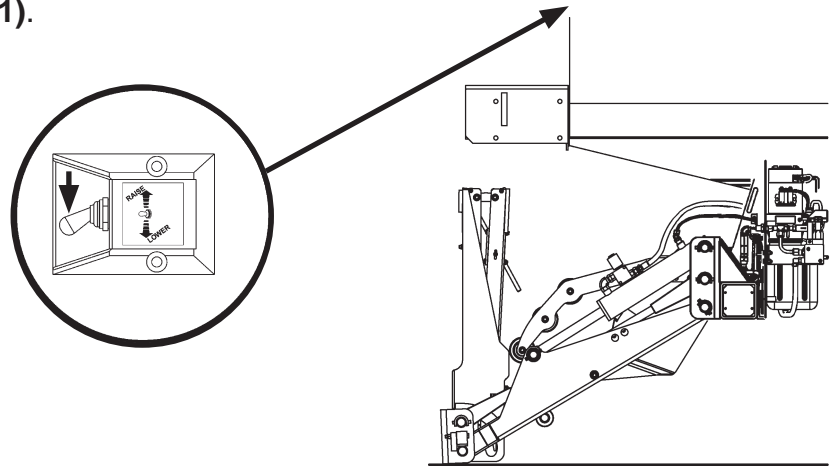

LOWERING PLATFORM TO GROUND WITH CONTROL SWITCH
FIG. 18-1

23. Unfold platform and flipover (**FIG. 18-2**).

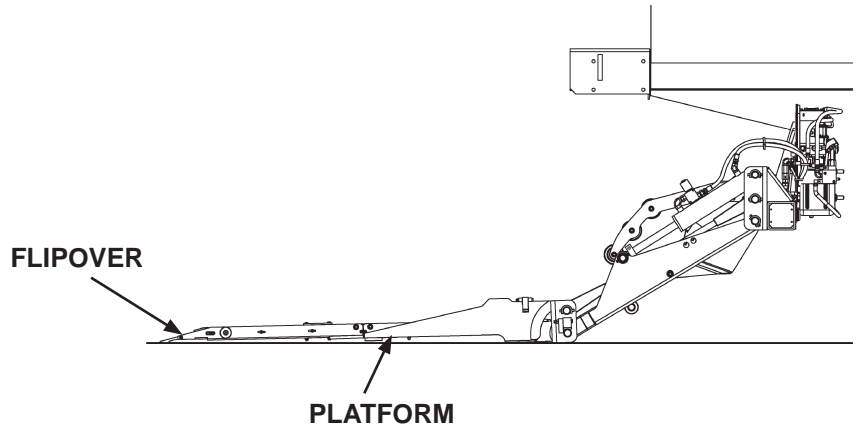

UNFOLDING PLATFORM AND FLIPOVER
FIG. 18-2

24. Use the control switch to **RAISE** platform to bed height (**FIG. 19-1**).

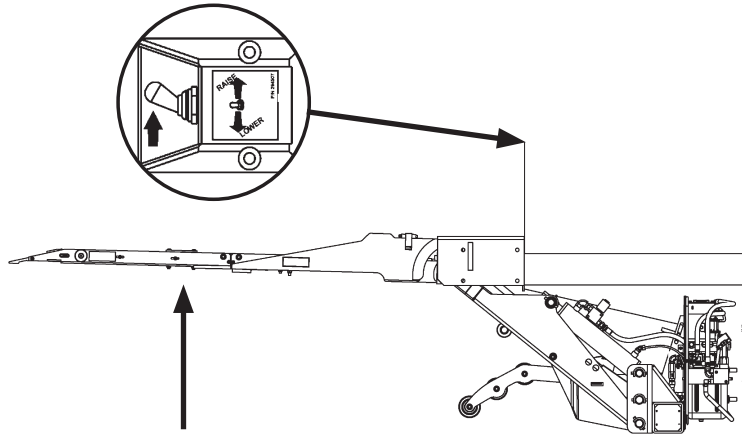

**RAISING PLATFORM TO BED HEIGHT
WITH CONTROL SWITCH
(GPTLR-25/-33 SHOWN)
FIG. 19-1**

25. Repeat steps 22 and 24 until all air has been bled from the system.
26. Refer to the **GPTLR Maintenance Manual** for instructions on checking hydraulic fluid.

27. Stow hand pump handle in the clips (**FIG. 20-1**).

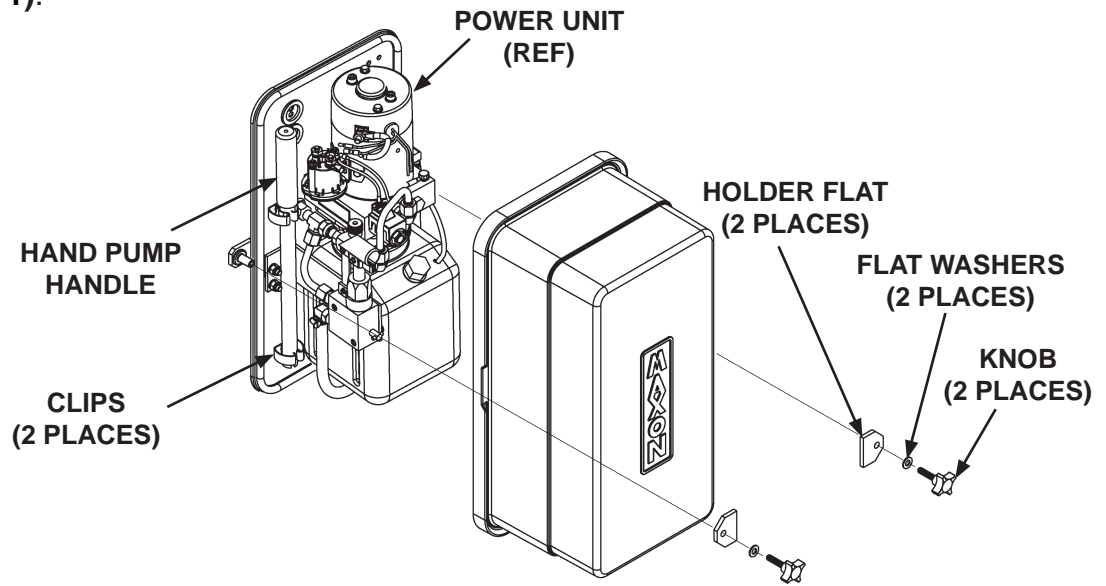

INSTALLING PUMP COVER
FIG. 20-1

28. Reinstall and fasten pump cover (**FIG. 20-1**). Hand-tighten knobs.

GPT HAND PUMP OPERATION INSTRUCTIONS

CAUTION

The hand pump is only intended for stowing the platform if the power unit does not work. Do not use for repeated loading and unloading of vehicle.

1. Unfasten and remove pump cover (FIG. 21-1).

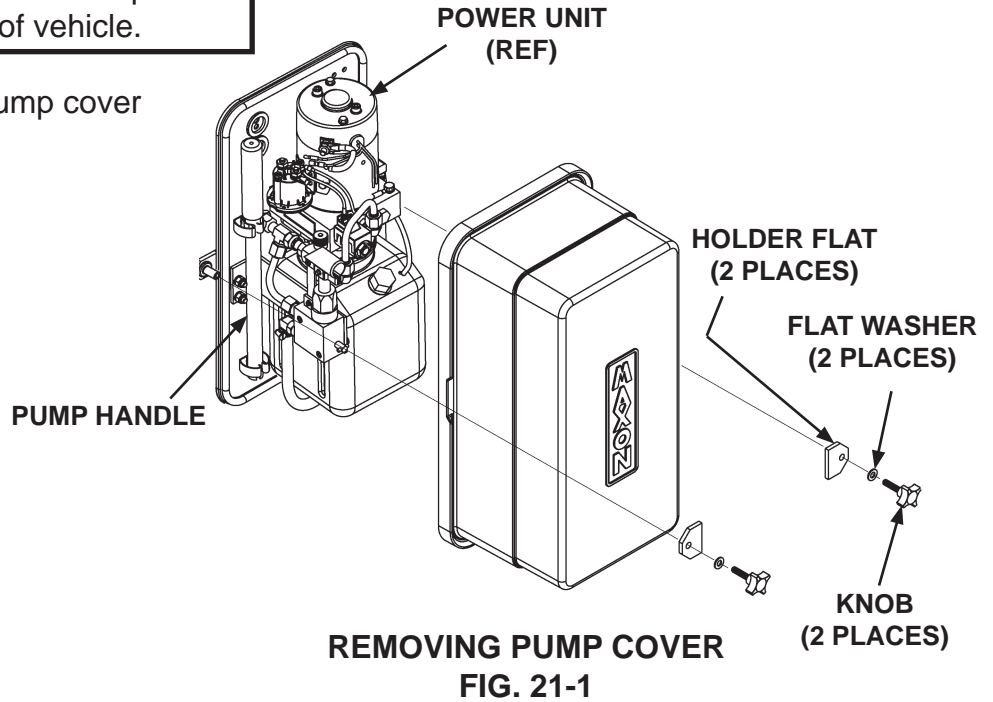

2. To use hand pump for backup operation, close needle valve by turning knob fully clockwise (FIG. 21-2).

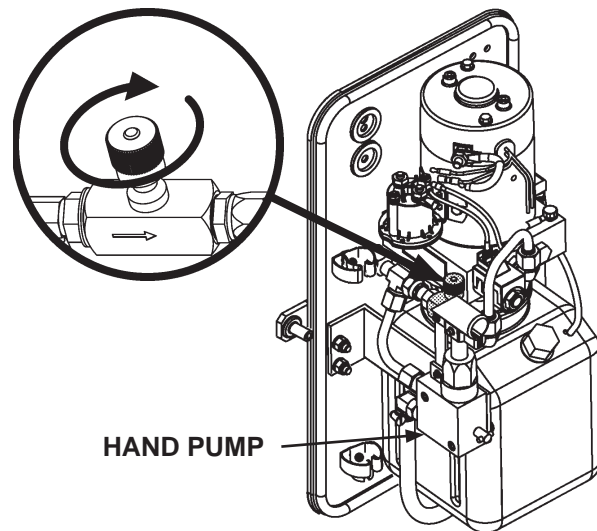

CLOSING NEEDLE VALVE
FIG. 21-2

3. Use the handle with hand pump to raise the platform (FIGS. 22-1 and 22-2).

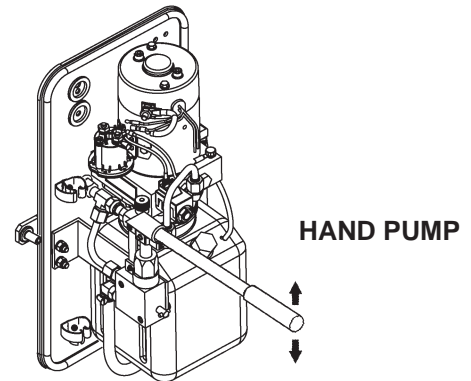

USING HAND PUMP TO RAISE PLATFORM
FIG. 22-1

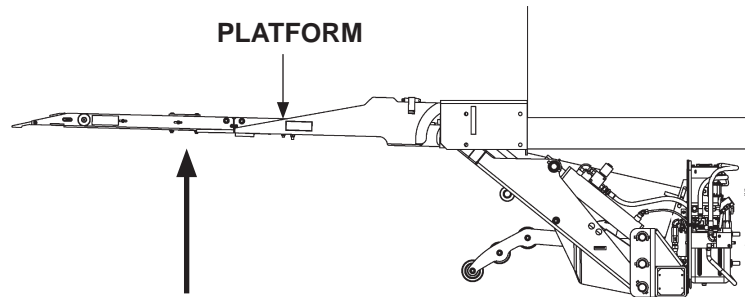

RAISING PLATFORM
FIG. 22-2

4. Remove plastic nut and slide coil from lock valve on RH cylinder. (FIG. 22-3).

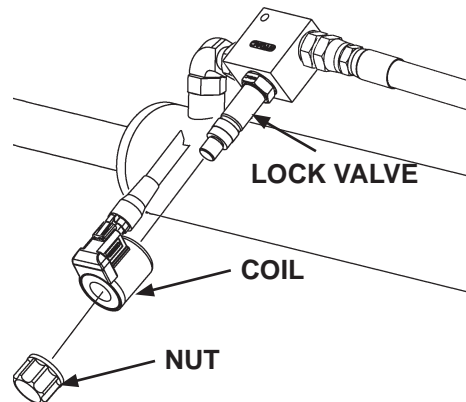

REMOVING COIL AND PLASTIC NUT
FIG. 22-3

5. Override (open) the lock valve by turning shaft fully counterclockwise (FIG. 23-1).

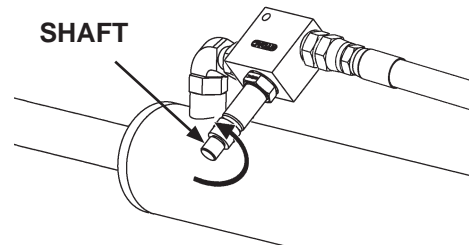

**OVERRIDING LOCK VALVE
FIG. 23-1**

6. Lower the platform by opening the hand pump release valve 1/2 turn counterclockwise with the handle (FIG. 23-2). Close the release valve (FIG. 23-2) by turning fully clockwise to stop platform from lowering.

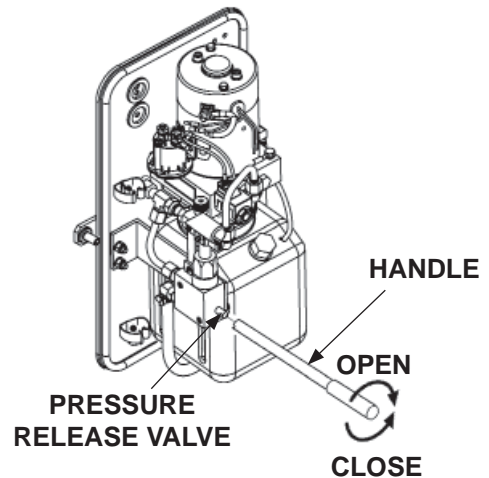

**OPENING/CLOSING PRESSURE
RELEASE VALVE
FIG. 23-2**

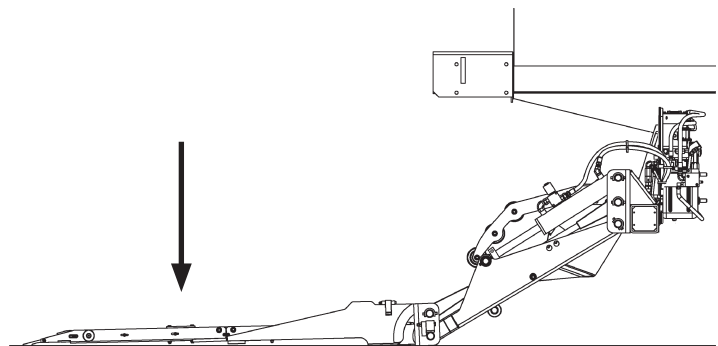

**LOWERING PLATFORM
FIG. 23-3**

7. Reset (close) the lock valve by turning shaft fully clockwise, **(FIG. 24-1)** so that it locks.

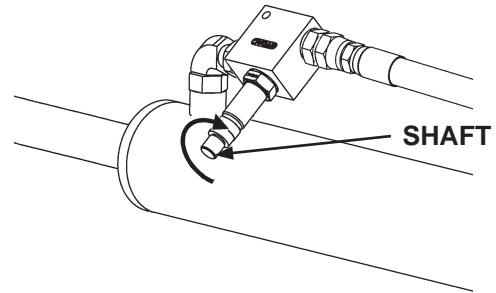

**RESETTING (CLOSE) LOCK VALVE
FIG. 24-1**

8. Reinstall coil and plastic nut **(FIG. 24-2)**.

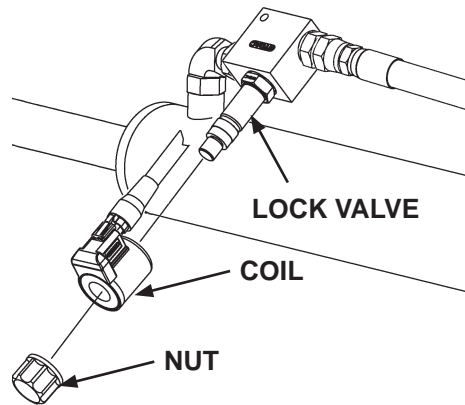

**REINSTALLING COIL AND PLASTIC NUT
FIG. 24-2**

9. For normal Liftgate operation with power unit, open the needle valve by turning knob fully counterclockwise. (FIG. 25-1).

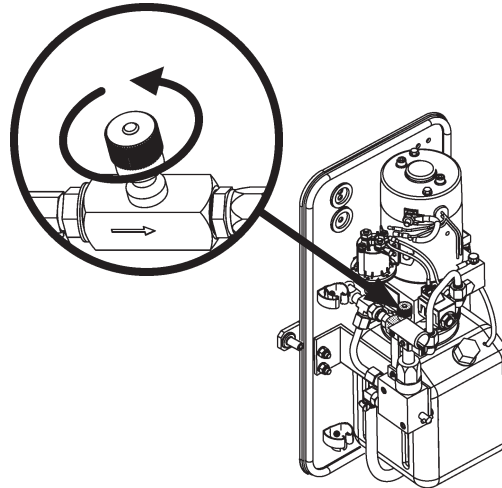

**OPENING NEEDLE VALVE FOR
NORMAL OPERATION
FIG. 25-1**

10. Stow the pump handle in the clips on pump mounting plate (FIG. 25-2).

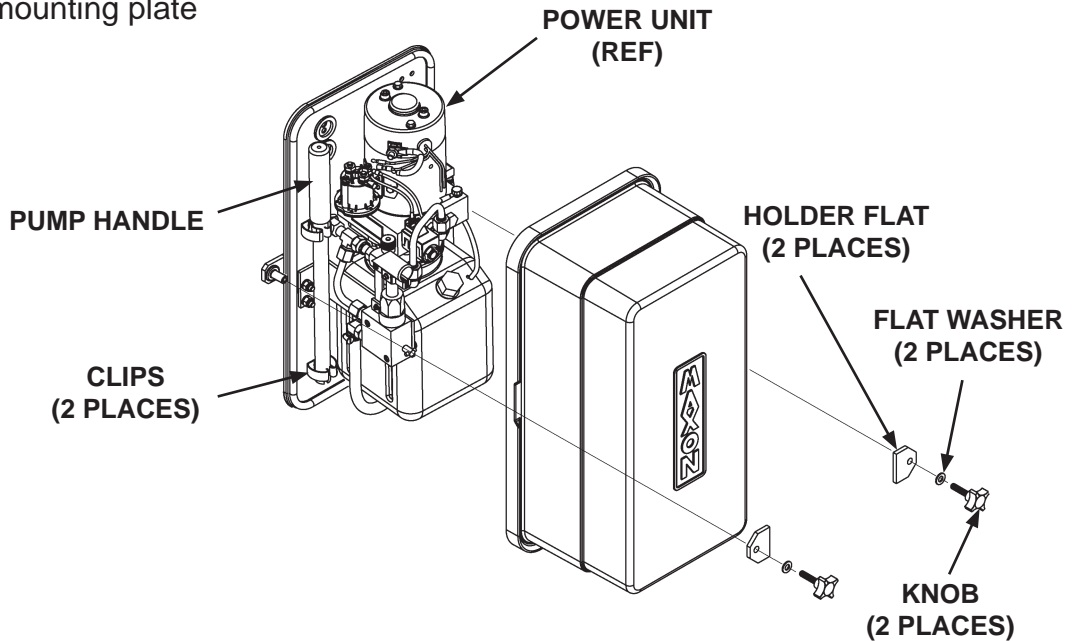

11. Reinstall and fasten pump cover (FIG. 25-2). Hand-tighten knobs.

**REINSTALLING PUMP COVER
FIG. 25-2**