

INSTRUCTION, DUAL CONTROL KIT P/N 297161-01

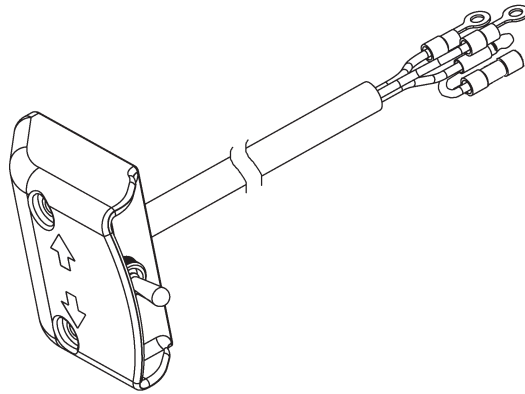

TOGGLE SWITCH ASSEMBLY, 205" LG
P/N 296855-04
QTY. 1



SELF-TAPPING SCREW
P/N 900057-5
QTY. 9



GROMMET
P/N 266428-12
QTY. 1

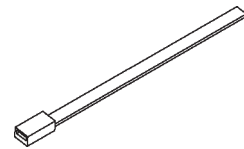

7" PLASTIC TIE
P/N 205780
QTY. 5



LOOM CLAMP #10
P/N 801681
QTY. 7

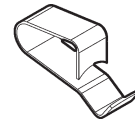

SPRING CLIP
P/N 050079
QTY. 3

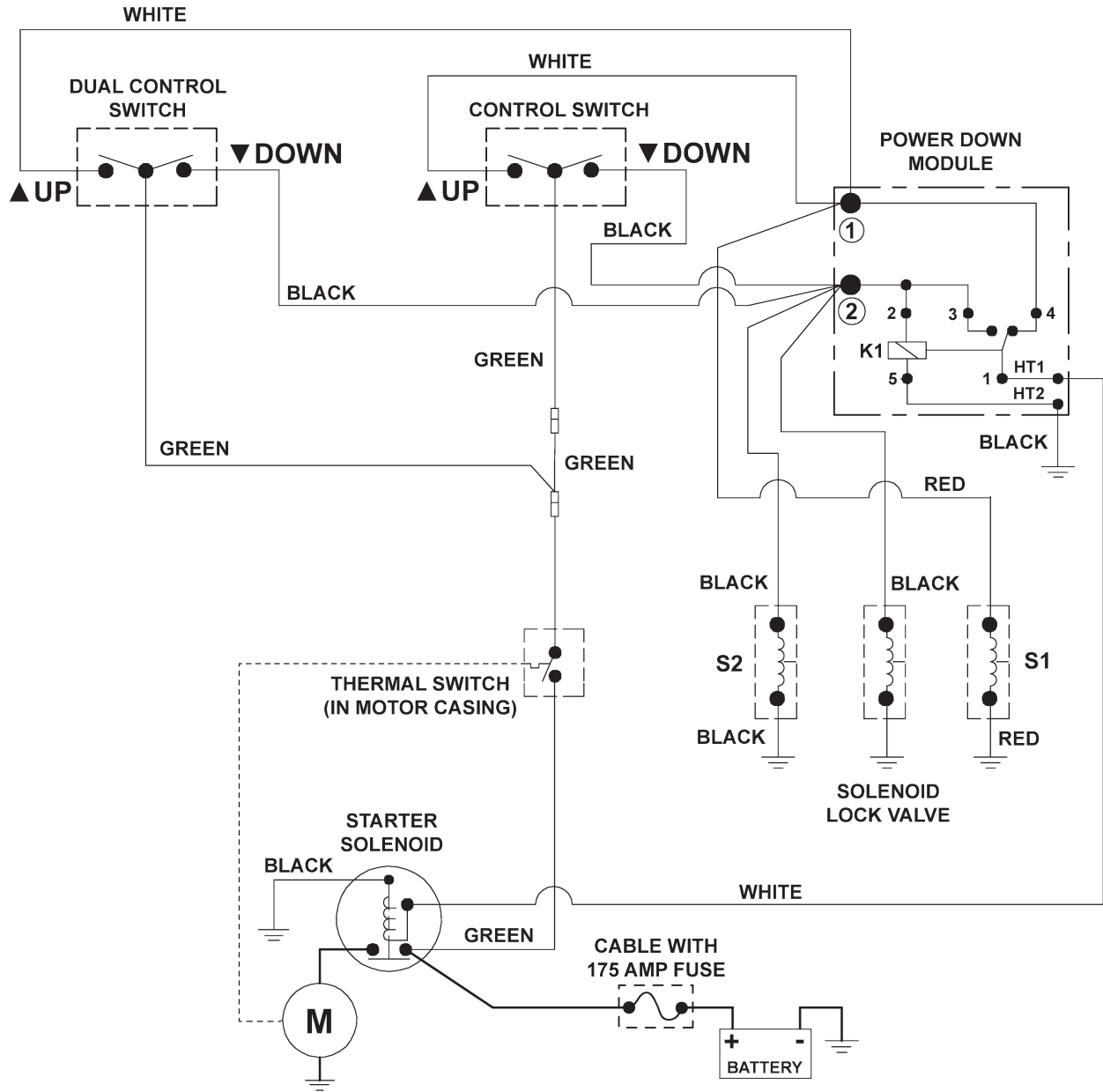

**GPT ELECTRICAL SCHEMATIC WITH OPTIONAL DUAL CONTROL SWITCH
FIG. 2-1**

⚠ WARNING

Remove all rings, watches and jewelry before doing any electrical work.

⚠ WARNING

To prevent accidental personal injury and equipment damage, disconnect (-) battery cable from battery.

⚠ WARNING

Never route an energized wire. Make sure battery is disconnected. Always route electrical wires clear of moving parts, brake lines, sharp edges and exhaust systems. Avoid making sharp bends in wiring. Attach securely. If drilling is necessary, first check behind the drilling surface so you do not damage any fuel lines, vent lines, brake lines or wires.

1. Lower platform to the ground. Then, unfold platform and flipover to the ground (**FIG. 3-1**). See **Operation Manual** for detailed operating instructions.

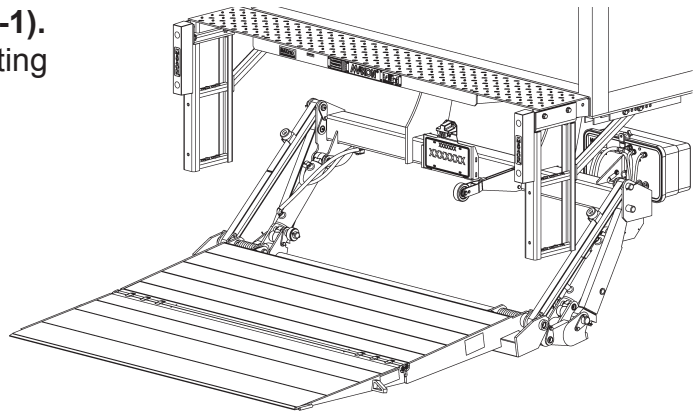

PLATFORM LOWERED TO THE GROUND
FIG. 3-1

2. Disconnect power from liftgate. Remove nut from negative (-) battery terminal (**FIG. 3-2**). Disconnect negative (-) battery cable (**FIG. 3-2**).

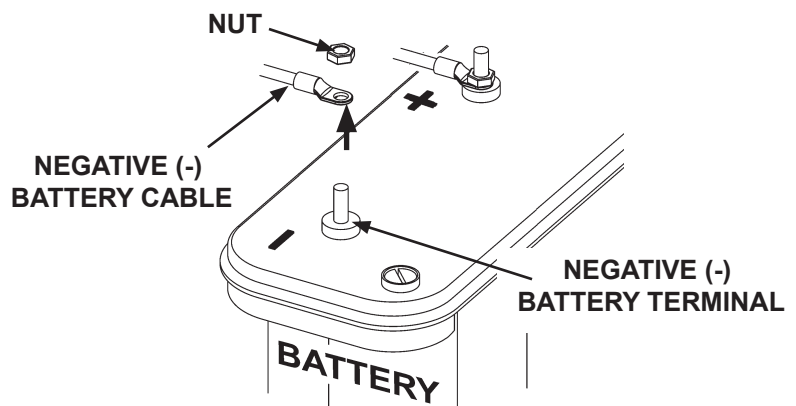

DISCONNECTING POWER
FIG. 3-2

3. Drill one 3/4" hole and two #21-size holes in the vertical post on curb side of vehicle body as shown in FIG. 4-1.

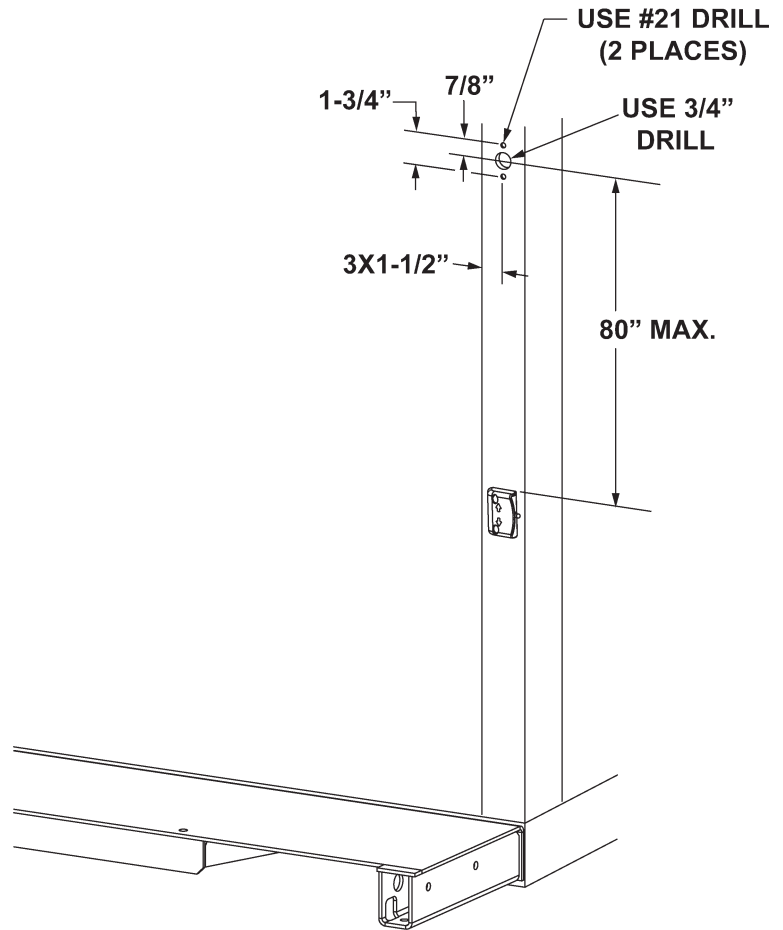

**DRILLING HOLES IN VEHICLE BODY
FIG. 4-1**

⚠ CAUTION

Always route electrical wires clear of moving parts, brake lines, sharp edges and exhaust systems. Avoid making sharp bends in wiring. Attach securely. If drilling is necessary, first check behind the drilling surface so you do not damage fuel lines, vent lines, brake lines or wires.

4. Insert control switch wiring into the 3/4" hole on the corner post and run it down, out and under the vehicle body to the pump assembly. (See dashed line - FIG. 5-1.) Secure wiring to vehicle body using frame clips and/or loom clamps with self tapping screws (Kit items). Then, attach switch in correct position on corner post.

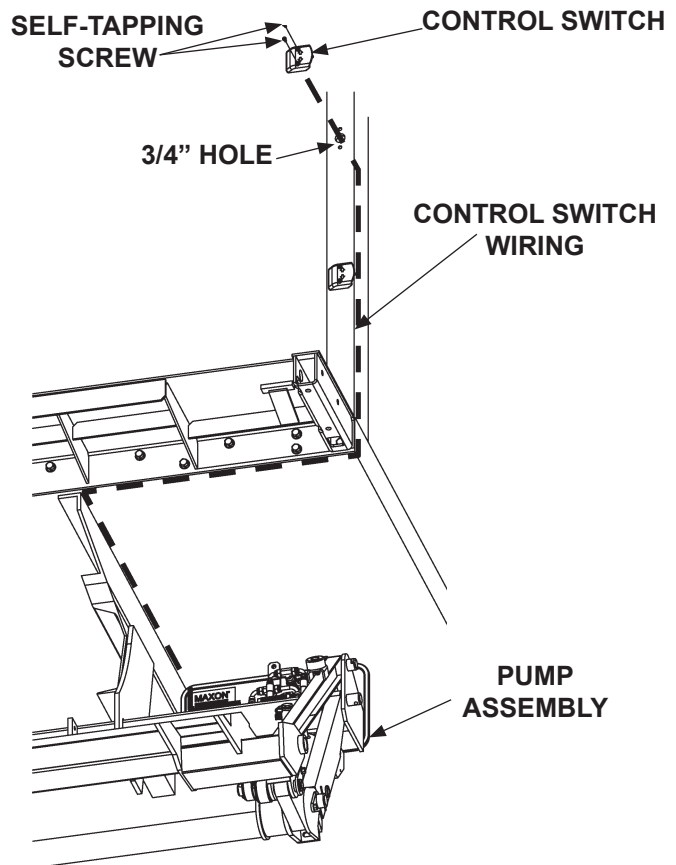

**CONTROL SWITCH WIRING
FIG. 5-1**

5. Disconnect ground cable from pump mounting bracket (**FIG. 6-1**). Remove existing grommet from pump mounting plate (**FIG. 6-1**). Insert new grommet (Kit item) into pump mounting plate.

6. Unbolt and remove pump cover (**FIG. 6-2**).

7. Insert switch wiring through new grommet on pump mounting plate (**FIG. 6-1**). Then, connect the switch wiring to the junction block as shown on the next page in **FIG. 7-1**.

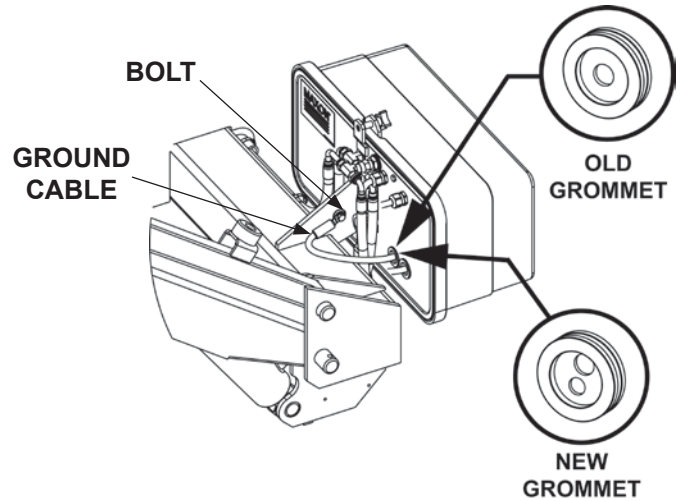

**REPLACING GROMMET
FIG. 6-1**

8. Reconnect ground cable to pump mounting bracket (**FIG. 6-1**).

9. Bolt on the pump cover as shown in **FIG. 6-2**.

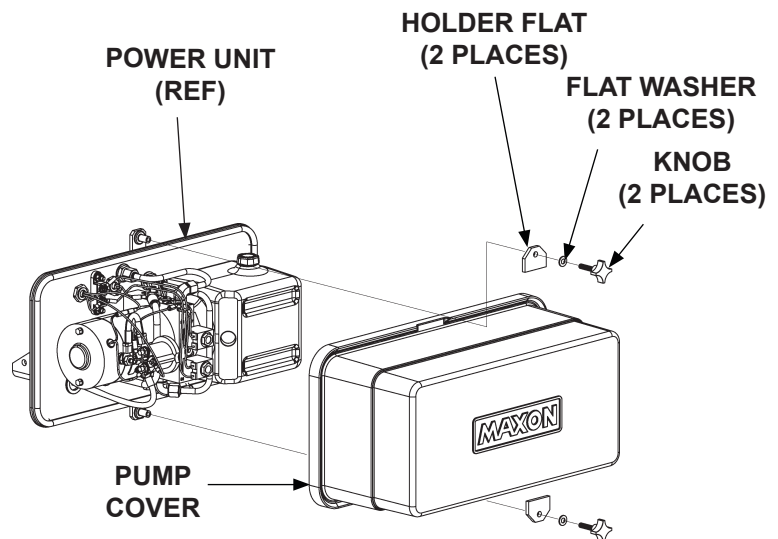

**BOLTING / UNBOLTING PUMP COVER
FIG. 6-2**

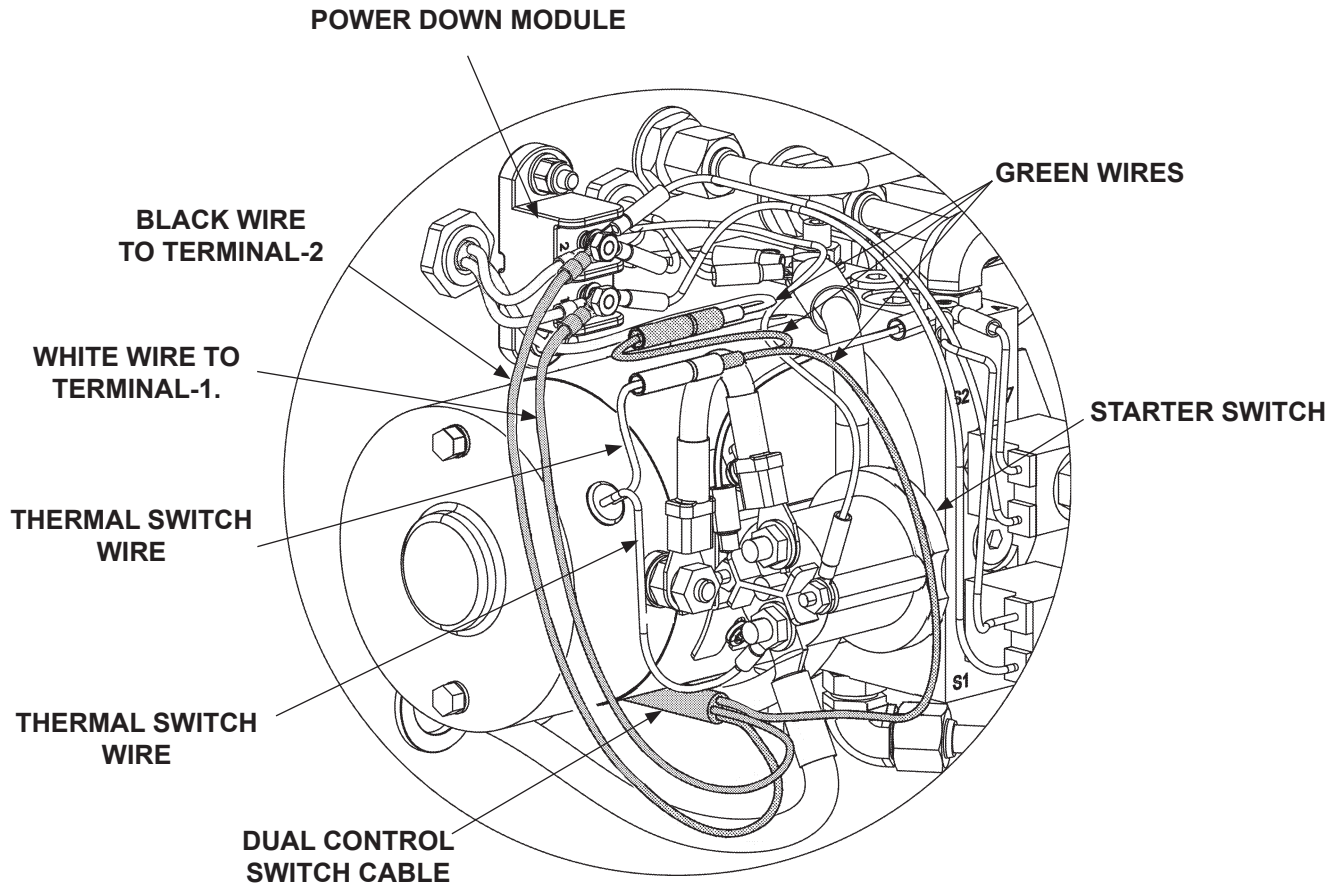

CONTROL SWITCH WIRING CONNECTIONS
FIG. 7-1

10. Reconnect power to liftgate.
Remove nut from negative (-) battery terminal (**FIG. 8-1**).
Connect negative (-) battery cable to the negative (-) battery terminal (**FIG. 8-1**).
Install and tighten nut.

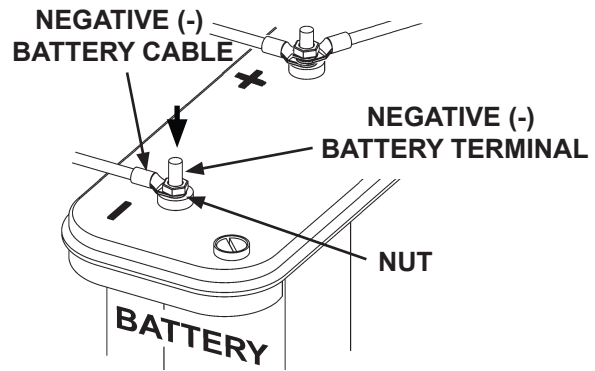

RECONNECTING POWER
FIG. 8-1

11. Verify dual control works correctly. Push control switch **UP** to raise platform (**FIG. 7-2**).
Then, push control switch **DOWN** (**FIG. 8-2**) to lower platform to the ground.

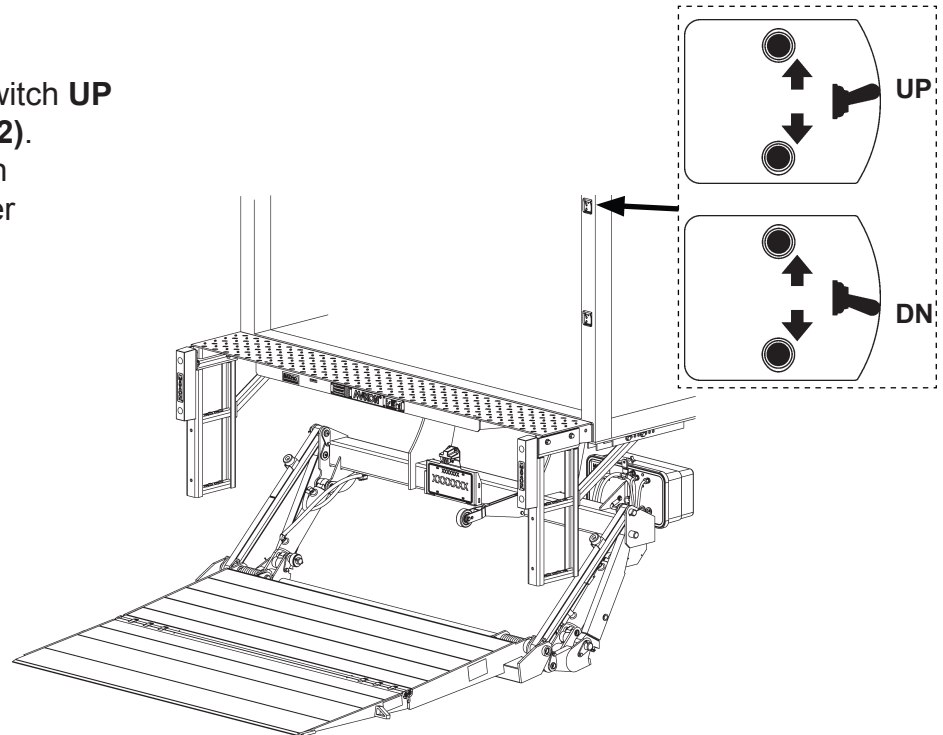

VERIFYING DUAL CONTROL SWITCH
FIG. 8-2