

M-07-13
REV. D
DECEMBER 2009

Installation Manual Contains:

- Warnings & Safety Instructions
- Requirements - Body Strength & Installed Liftgate
- Liftgate Installation Components
- Liftgate Component Installation Instructions
- Hydraulic Fluid Filling Instructions
- Decals
- Hydraulic & Electrical System Diagrams
- Pre-delivery Inspection Form

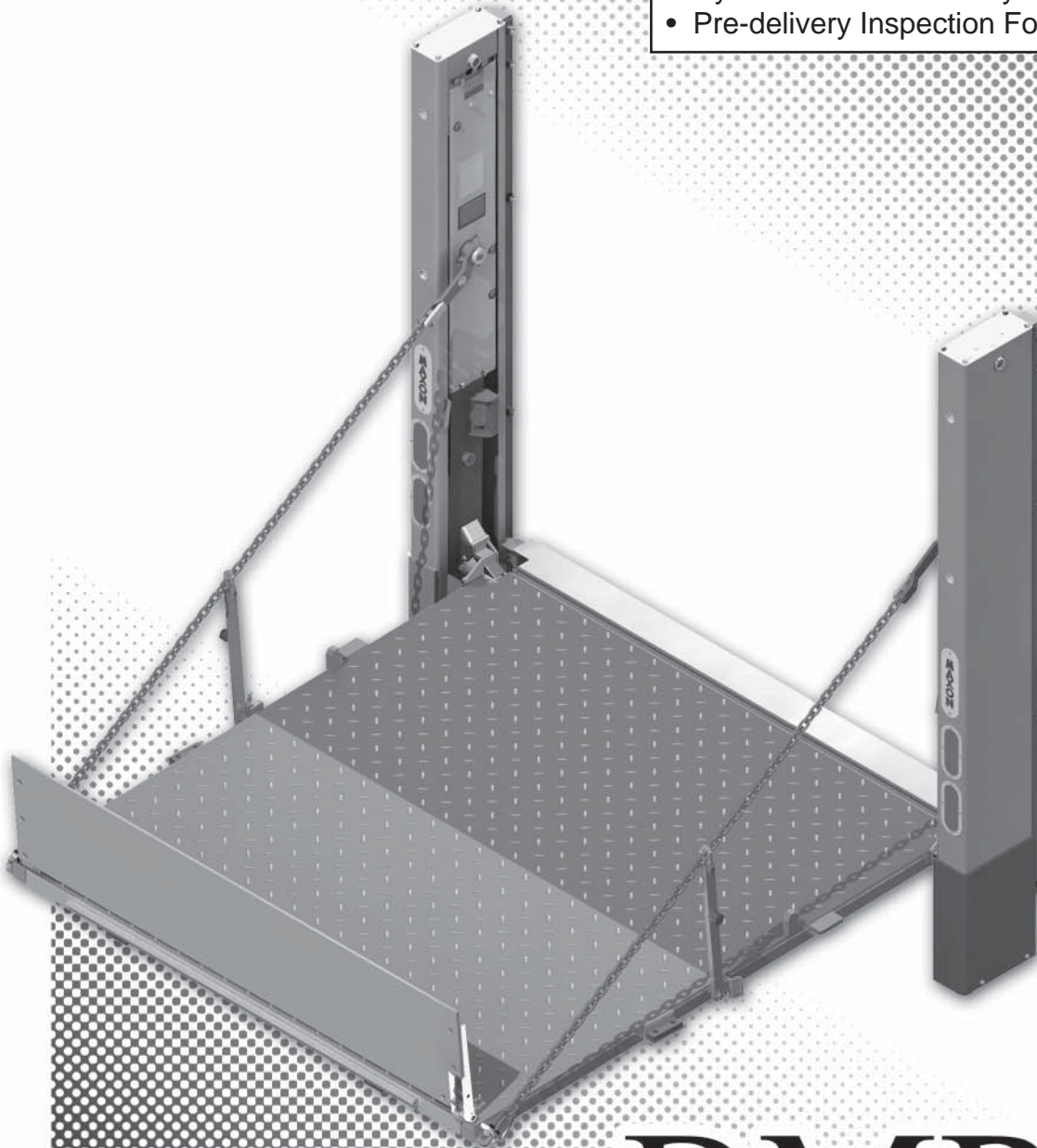

MAXON[®]
LIFT CORP.

BMRSD

INSTALLATION MANUAL

TABLE OF CONTENTS

WARNINGS	4
VEHICLE REQUIREMENTS	5
BODY STRENGTH.....	5
INSTALLED LIFTGATE	7
LIFTGATE INSTALLATION COMPONENTS	8
COMPONENTS	9
STEP 1 - PREPARE VEHICLE IF REQUIRED	10
STEP 2 - POSITION LIFTGATE	12
PRE-INSTALL MOUNTING BRACKETS AND EXTENSION PLATE	12
WELDING LIFTGATE TO BODY.....	16
STEP 3 - BOLT LIFTGATE TO VEHICLE (IF REQUIRED)	18
STEP 4 - POSITION PUMP BOX FRAME	20
STEP 5 - WELD PUMP BOX FRAME TO VEHICLE.....	21
STEP 6 - RUN HYDRAULIC LINES & ELECTRIC CABLES.....	24
RUN HYDRAULIC LINES.....	25
RUN ELECTRIC CABLES.....	26
STEP 7 - CONNECT GROUND CABLE	27
GROUNDING TO TRUCK FRAME	27
GROUNDING TO BATTERY BOX (IF EQUIPPED)	28
STEP 8 - INSTALL CONTROL BOX & BRACKET	29
STEP 9 - RUN CHARGE LINES	30
STEP 10 - CONNECT BATTERIES TO LIFTGATE	31
STEP 11 - ADD HYDRAULIC FLUID TO RESERVOIR.....	32
STEP 12 - PRESSURIZE HYDRAULIC SYSTEM	33
STEP 13 - REMOVE LOWER SUPPORT FIXTURE.....	34

TABLE OF CONTENTS - Continued

STEP 14 - OPTIMIZE HYDRAULIC FLUID LEVEL.....	35
STEP 15 - FINISH WELDING LIFTGATE TO VEHICLE	38
STEP 16 - PLATFORM CHAIN ADJUSTMENT	42
STEP 17 - REMOVE UPPER SUPPORT FIXTURES	46
STEP 18 - REPLACE NUTS ON MOUNTING BRACKETS	47
STEP 19 - PLACE "ALIGN ARROWS" DECAL.....	48
ATTACH DECALS	49
TOUCHUP PAINT	51
OPTIONS	52
RECOMMENDED LIFTGATE POWER CONFIGURATION	52
HYDRAULIC SYSTEM DIAGRAMS.....	54
PUMP & MOTOR SOLENOID OPERATION - POWER DOWN.....	54
PUMP & MOTOR SOLENOID OPERATION - GRAVITY DOWN.....	55
SINGLE PUMP BOX HYDRAULIC SCHEMATIC.....	56
DUAL PUMP BOX HYDRAULIC SCHEMATIC	57
ELECTRICAL SYSTEM DIAGRAMS	58
INTERCONNECTING ELECTRICAL SCHEMATIC.....	58
SINGLE PUMP BOX ELECTRICAL SCHEMATIC	59
DUAL PUMP BOX ELECTRICAL SCHEMATIC	60
PRE-DELIVERY INSPECTION FORM.....	61

Comply with the following **WARNINGS** and **SAFETY INSTRUCTIONS** while installing Liftgates. See Operation Manual for operating safety requirements.

WARNING

- Do not stand, or allow obstructions, under the platform when lowering the Liftgate. **Be sure your feet are clear of the Liftgate.**
- **Keep fingers, hands, arms, legs, and feet clear of moving Liftgate parts (and platform edges) when operating the Liftgate.**
- **Correctly stow platform when not in use. Extended platforms could create a hazard for people and vehicles passing by.**
- **Make sure vehicle battery power is disconnected** while installing Liftgate. Connect vehicle battery power to the Liftgate only when installation is complete or as required in the installation instructions.
- If it is necessary to stand on the platform while operating the Liftgate, keep your feet and any objects clear of the inboard edge of the platform. Your feet or objects on the platform can become trapped between the platform and the Liftgate extension plate.
- Never perform unauthorized modifications on the Liftgate. Modifications may result in early failure of the Liftgate and may create hazards for Liftgate operators and maintainers.
- Recommended practices for welding on steel parts are contained in the current **AWS (American Welding Society) D1.1 Structural Welding Code - Steel**. Damage to Liftgate and/or vehicle, and personal injury can result from welds that are done incorrectly.

SAFETY INSTRUCTIONS

- Read and understand the instructions in this **Installation Manual** before installing Liftgate.
- Before operating the Liftgate, read and understand the operating instructions in **Operation Manual**.
- Comply with all **WARNING** and instruction decals attached to the Liftgate.
- Keep decals clean and legible. If decals are illegible or missing, replace them. Free replacement decals are available from **Maxon Customer Service**.
- Consider the safety and location of bystanders and location of nearby objects when operating the Liftgate. Stand to one side of the platform while operating the Liftgate
- Do not allow untrained persons or children to operate the Liftgate.
- Wear appropriate safety equipment such as protective eyeglasses, faceshield and clothing while performing maintenance on the Liftgate and handling the battery. Debris from drilling and contact with battery acid may injure unprotected eyes and skin.
- Be careful working by an automotive type battery. Make sure the work area is well ventilated and there are no flames or sparks near the battery. Never lay objects on the battery that can short the terminals together. If battery acid gets in your eyes, immediately seek first aid. If acid gets on your skin, immediately wash it off with soap and water.
- If an emergency situation arises (vehicle or Liftgate) while operating the Liftgate, release the control switch to stop the Liftgate.
- A correctly installed Liftgate operates smoothly and reasonably quiet. The only noticeable noise during operation comes from the power unit while the platform is raised and lowered. Listen for scraping, grating and binding noises and correct the problem before continuing to operate Liftgate.

VEHICLE REQUIREMENTS

NOTE: Installer is responsible for ensuring vehicle meets Federal, State, and Local standards and regulations.

BODY STRENGTH

⚠ WARNING

Consult vehicle body manufacturer for vehicle body strength data. Make sure the forces created by the Liftgate are within the limits prescribed by the vehicle body manufacturer.

NOTE: Maximum operating bed height for body is **56" (Unloaded)**. Minimum is **32" (Loaded)**. Do not install this Liftgate on vehicle bodies equipped with swing open doors.

The BMRSD is a body-mounted Liftgate that puts forces on the side walls of truck and trailer bodies (**FIG. 5-1**). For correct installation, truck and trailer bodies must be strong enough to withstand the tension, compression and shear forces shown in **FIG. 5-1**. Use **TABLES 6-1 and 6-2** on the following page to determine the forces that apply to the type of platform, size of platform, and load capacity of your Liftgate.

X= Tension on each sidewall
Y= Compression on each sidewall
Z= Shear on each sidewall

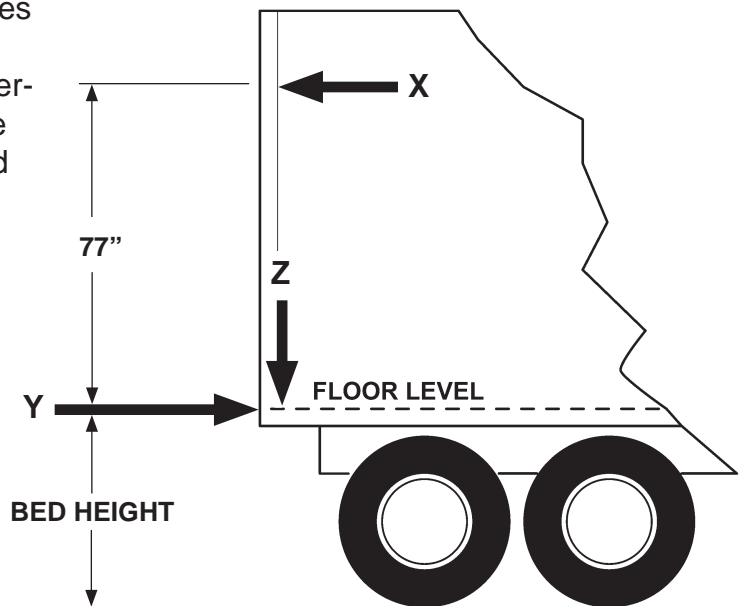

FIG. 5-1

VEHICLE REQUIREMENTS - Continued

BODY STRENGTH - Continued

MODEL CAPACITY	P/F SIZE	(X)(Y) LBS.	(Z) LBS.
BMR-35 3500 LBS. (STEEL PLATFORM)	84	2101	4176
	72	1780	4071
BMR-44 4400 LBS. (STEEL PLATFORM)	84	2504	4851
	72	2110	4746

TABLE 6-1

MODEL CAPACITY	P/F SIZE	(X)(Y) LBS.	(Z) LBS.
BMR-55 5500 LBS. (STEEL PLATFORM)	84	2998	5676
	72	2559	5571
BMR-66 6600 LBS. (STEEL PLATFORM)	84	3491	6501
	72	2989	6396

TABLE 6-2

VEHICLE REQUIREMENTS - Continued

INSTALLED LIFTGATE

NOTE: If Liftgate columns exceed a 91 degree angle from level ground when installed on body, or if columns cannot be mounted flush against rear of vehicle, a steel filler may be used to bridge gap between vehicle body and Liftgate columns. Make sure the added materials and welds meet the **BODY STRENGTH** requirements shown on the previous pages.

With the vehicle parked on level ground, the columns of the BMRSD must be perpendicular to the ground (vertical) for the Liftgate to operate correctly (FIGS. 7-1 and 7-2).

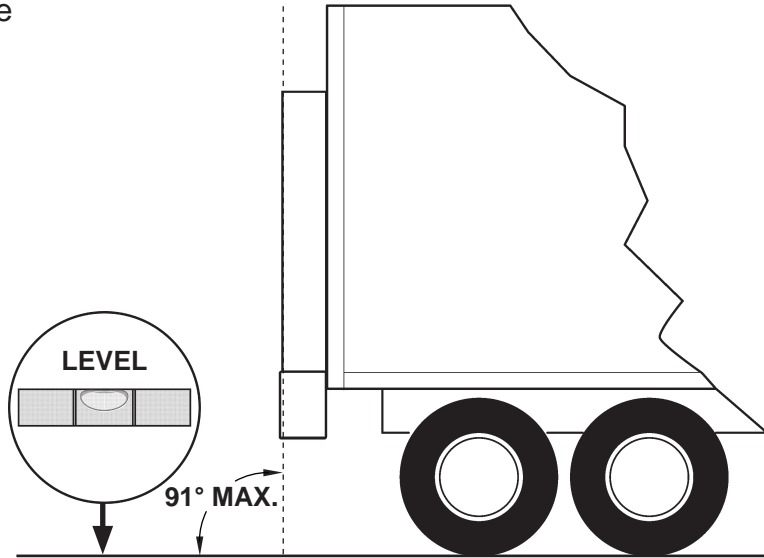

LIFTGATE INSTALLED ON VAN BODY (COLUMNS SHOWN PERPENDICULAR TO LEVEL GROUND)
FIG. 7-1

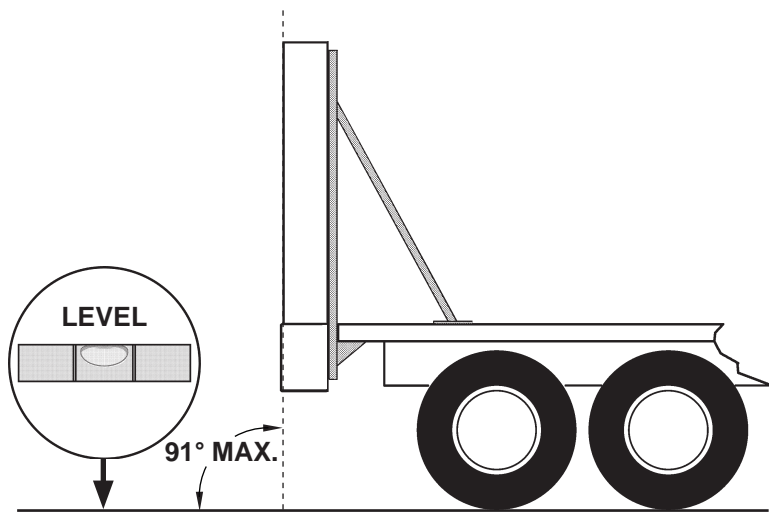

LIFTGATE INSTALLED ON FLAT BED (COLUMNS & SUPPORTS SHOWN PERPENDICULAR TO LEVEL GROUND)
FIG. 7-2

LIFTGATE INSTALLATION COMPONENTS

Each BMRSD Liftgate includes items shown in **FIG. 8-1**.

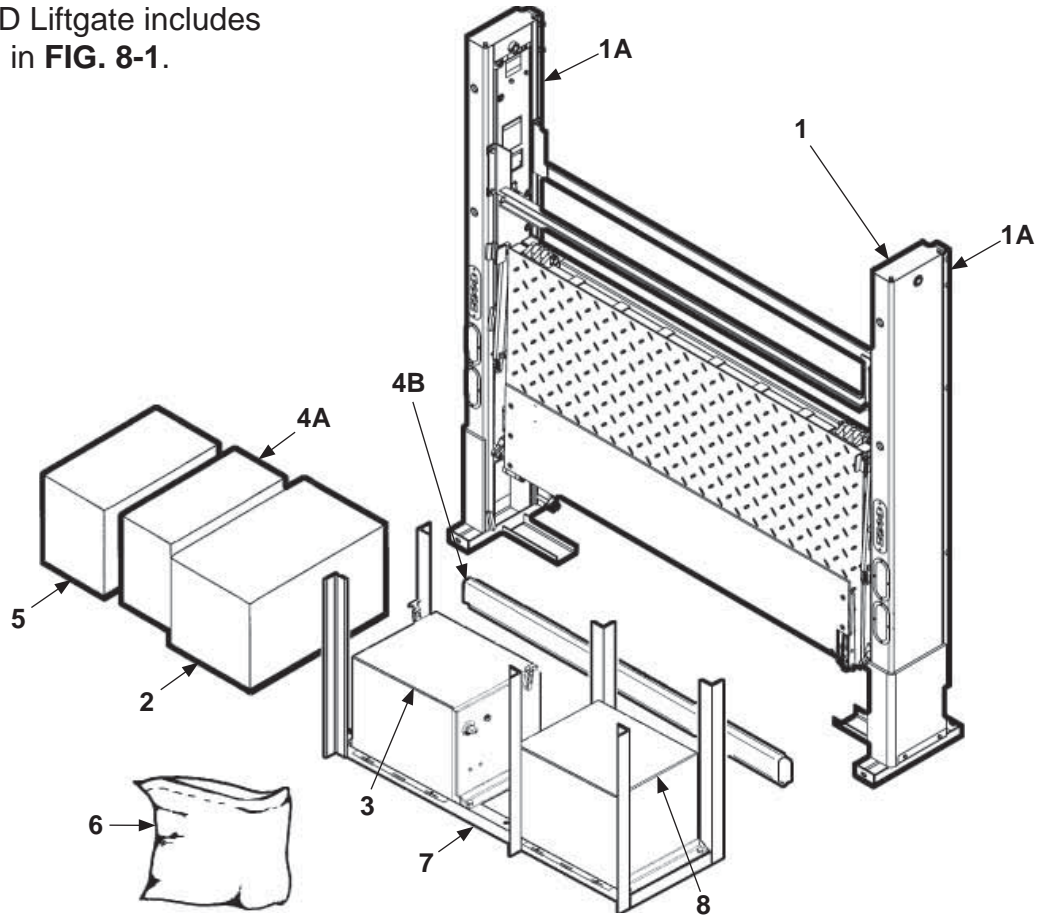

FIG. 8-1

DESCRIPTION	
1	BMRSD Liftgate
1A	Optional Mounting Brackets
2	Hardware parts bag, flat stock & bracket parts bag, hydraulic lines & fittings, wiring harness, power cable, molded switch control box
3	Pump box assembly
4A	Installation kit (3', 10', or 20')
4B	Channel guards (for 10' & 20' installation kits only)
5	Optional equipment: tractor charge lines & hand held control
6	Instruction manuals and decals
7	Frame for pump box with optional battery box is shown. A shorter frame is also available for mounting single pump box or an optional battery box.
8	Battery box (optional)

TABLE 8-1

COMPONENTS

NOTE: Make sure you have components and parts before you start installing Liftgate. Compare parts in the part box and each kit box with packing list enclosed in each box. If parts and components are missing or incorrect, call:

Maxon Customer Service
Call (800) 227-4116 or
Send e-mail to cservice@maxonlift.com

BMRSD MODEL (POWER DN-PD)	MANUAL & DECAL KIT	PART BOX	3 FT PUMP BOX INSTALL KIT	10 FT PUMP BOX INSTALL KIT	20 FT PUMP BOX INSTALL KIT	SINGLE PUMP ASSY	DUAL PUMP ASSY	FRAME SINGLE PUMP ASSY OR BATTERY BOX	FRAME PUMP ASSY & BATTERY BOX
BMRSD 35 PD	268347-01	268345-01	268346-01	268346-02	268346-03	268130-01	268340-01	280279-100	280280-100
BMRSD 44 PD	268347-02								
BMRSD 55 PD	268347-03								
BMRSD 66 PD	268347-04								

BMRSD MODEL (POWER DN-PD)	TRUCK CHARGE LINE	SINGLE POLE TRAILER CHARGE LINE	DUAL POLE TRAILER CHARGE LINE	OPTIONS			
				SINGLE POLE TRACTOR CHARGE LINE	DUAL POLE TRACTOR CHARGE LINE	TRACTOR CHARGE LINE WITH ADAPTER	HAND HELD CONTROL
BMRSD 35 PD	280290	280275-01	280275-02	280275-03	280275-04	280275-05	263260-08
BMRSD 44 PD							
BMRSD 55 PD							
BMRSD 66 PD							

BMRSD MODEL (POWER DN-PD)	OPTIONS						
	LOW VOLTAGE SWITCH (1 KIT FOR SINGLE PUMP, 2 KITS FOR DUAL PUMP)	CYCLE COUNTER	HEADER KIT	KIT, TRAIL CHARGER	KIT, HIGH PERFORMANCE CHARGE	BATTERY	KIT, TOUCHUP PAINT WITH ZINC PRIMER
BMRSD 35 PD	280546-01	280590-01	263490-400	267370-01	267580-01	267318-01	908118-01
BMRSD 44 PD							
BMRSD 55 PD							
BMRSD 66 PD							

TABLE 9-1

STEP 1 - PREPARE VEHICLE IF REQUIRED

NOTE: Perform the following step for flatbed vehicle body only. If vehicle body is not a flatbed, skip this step.

NOTE: LH and RH supports must be perpendicular to level ground. See **VEHICLE REQUIREMENTS, INSTALLED LIFTGATE.**

NOTE: Materials for support framework are not provided with Liftgate.

⚠ WARNING

Recommended practices for welding on steel parts are contained in the current AWS (American Welding Society) D1.1 Structural Welding Code - Steel. Damage to Liftgate and/or vehicle, and personal injury can result from welds that are done incorrectly.

1. Fabricate framework, as shown in **FIGS. 10-1A, -1B & -1C**, to support Liftgate on a flatbed vehicle. Then, go to the next page for welding instructions.

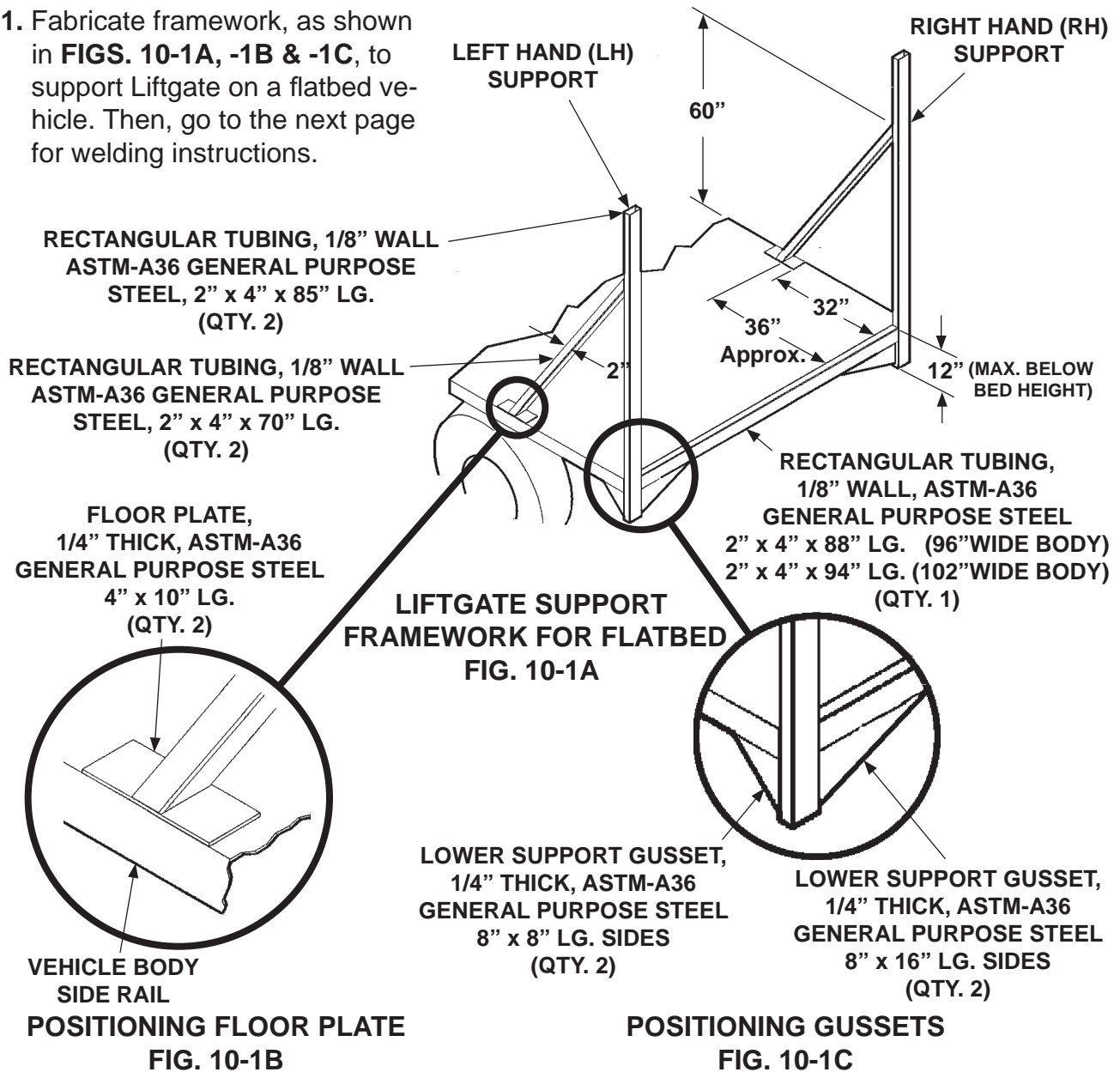

STEP 1 - PREPARE VEHICLE IF REQUIRED - Continued

2. Weld Liftgate supports, as shown in FIGS. 11-1A, -1B, -1C & -1D.

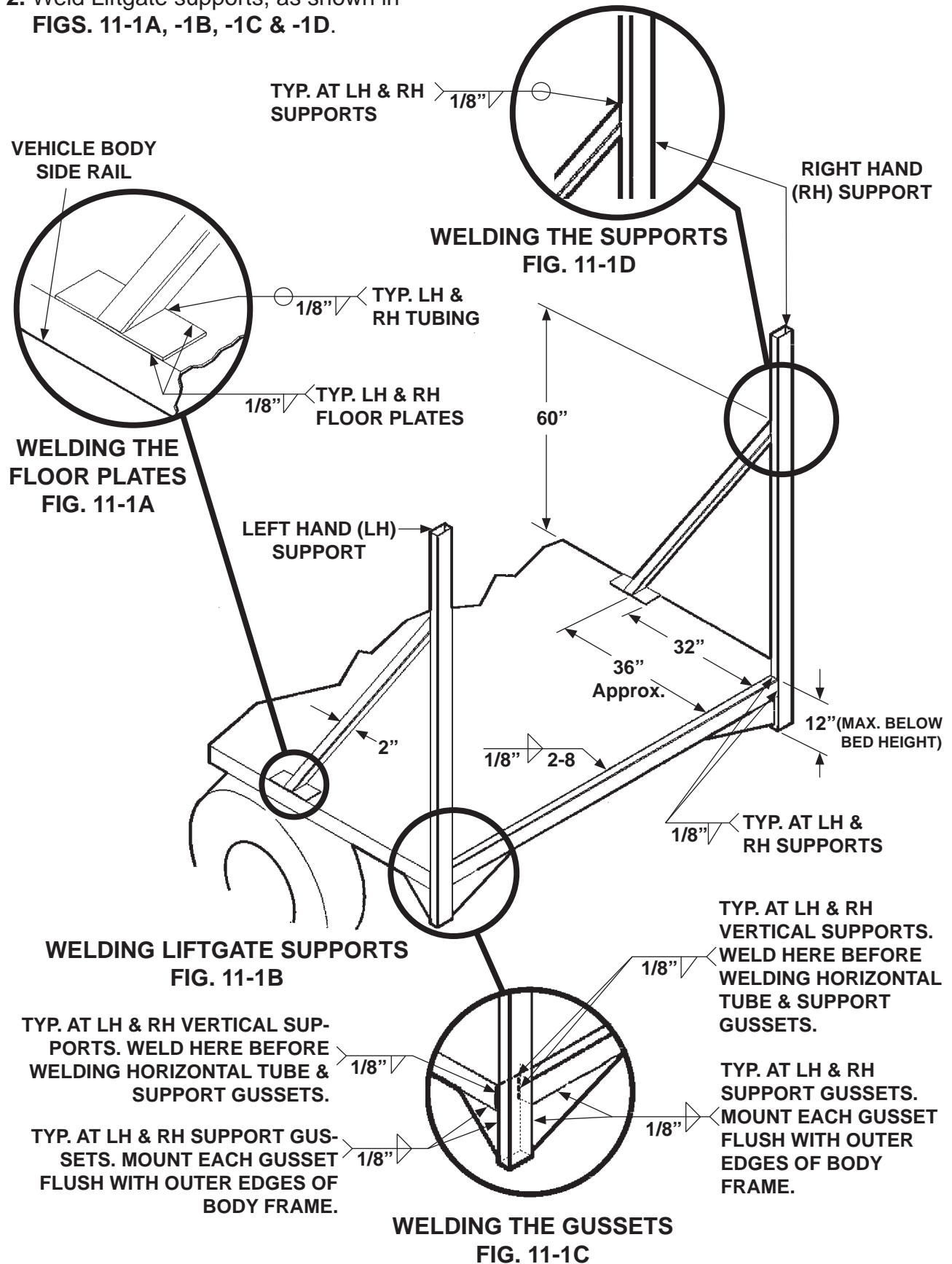

11921 Slauson Ave. Santa Fe Springs, CA. 90670 (800) 227-4116 FAX (888) 771-7713

MAXON

STEP 2 - POSITION LIFTGATE

NOTE: MAXON recommends pre-installing the extension plate, column mounting brackets, and control box bracket on the vehicle body before installing the Liftgate.

Alternate method 1: For Liftgate equipped with column mounting brackets, use Liftgate as a fixture to position and weld the brackets to vehicle body.

Alternate method 2: For Liftgate not equipped with column mounting brackets, weld columns directly to vehicle body.

CAUTION

Some mild steel Liftgate mounting channels and extension plates are coated with a protective film and shipped unpainted. The film, if not removed for painting, can cause paint to separate from surface. Use a suitable solvent to remove the protective film before painting.

NOTE: Before installing the mounting channels and extension plate, use a solvent such as Houghton-Clean 221 or Certa-Kleen S-7 or S-8 to remove the protective film from these parts.

PRE-INSTALL MOUNTING BRACKETS AND EXTENSION PLATE

1. Cut both LH and RH extension plate ends (**FIG. 12-1**) until flush with gusset (**FIG. 12-2**).

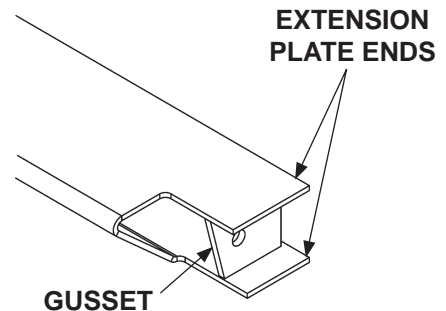

EXTENSION PLATE
BEFORE CUT
FIG. 12-1

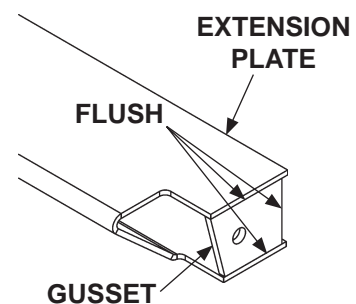

EXTENSION PLATE
AFTER CUT
FIG. 12-2

STEP 2 - POSITION LIFTGATE - Continued

PRE-INSTALL MOUNTING BRACKETS AND EXTENSION PLATE - Continued

⚠ WARNING

Recommended practices for welding on steel parts are contained in the current AWS (American Welding Society) D1.1 Structural Welding Code - Steel. Damage to Liftgate and/or vehicle, and personal injury can result from welds that are done incorrectly.

- Center the extension plate on rear of vehicle body and flush with top of the rear sill. Then, weld as shown in **FIG. 13-1**.

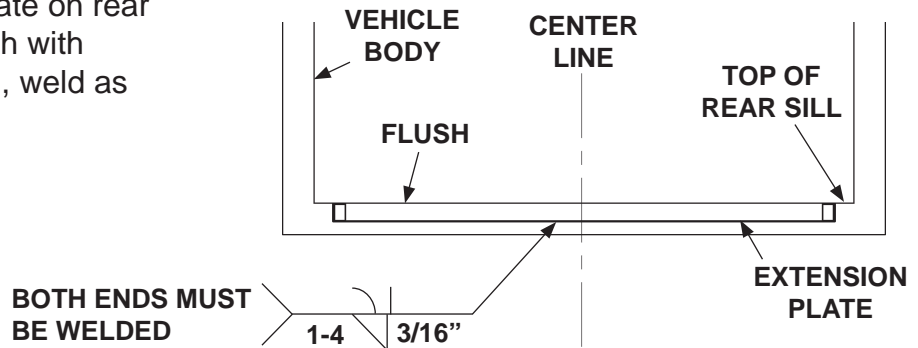

NOTE: Distance between extension plate and RH mounting bracket is measured from the inside wall of mounting bracket as shown in illustration.

- Position RH mounting bracket as shown in **FIGS. 13-2A and 13-2B**. Then, weld RH mounting bracket to vehicle.

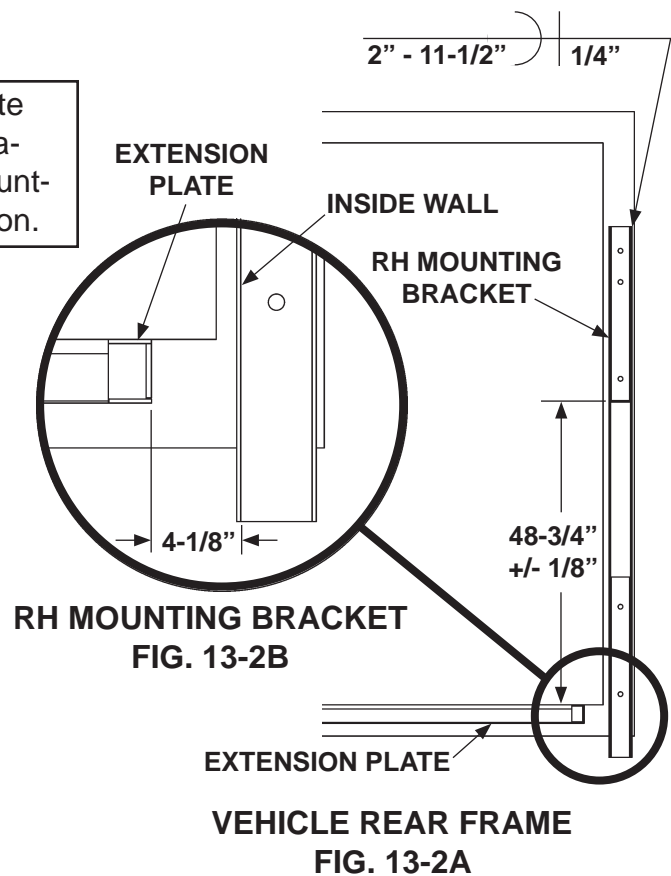

MAXON® 11921 Slauson Ave. Santa Fe Springs, CA. 90670 (800) 227-4116 FAX (888) 771-7713

STEP 2 - POSITION LIFTGATE - Continued

PRE-INSTALL MOUNTING BRACKETS AND EXTENSION PLATE - Continued

NOTE: Distance between LH & RH mounting brackets is measured from the inside wall of each bracket as shown in the illustrations below.

4. Position LH mounting bracket on vehicle body as shown in **FIGS. 14-1A, 14-1B, and 14-1C**. Then, weld LH mounting bracket to vehicle body (**FIGS. 14-1A and 14-1B**).

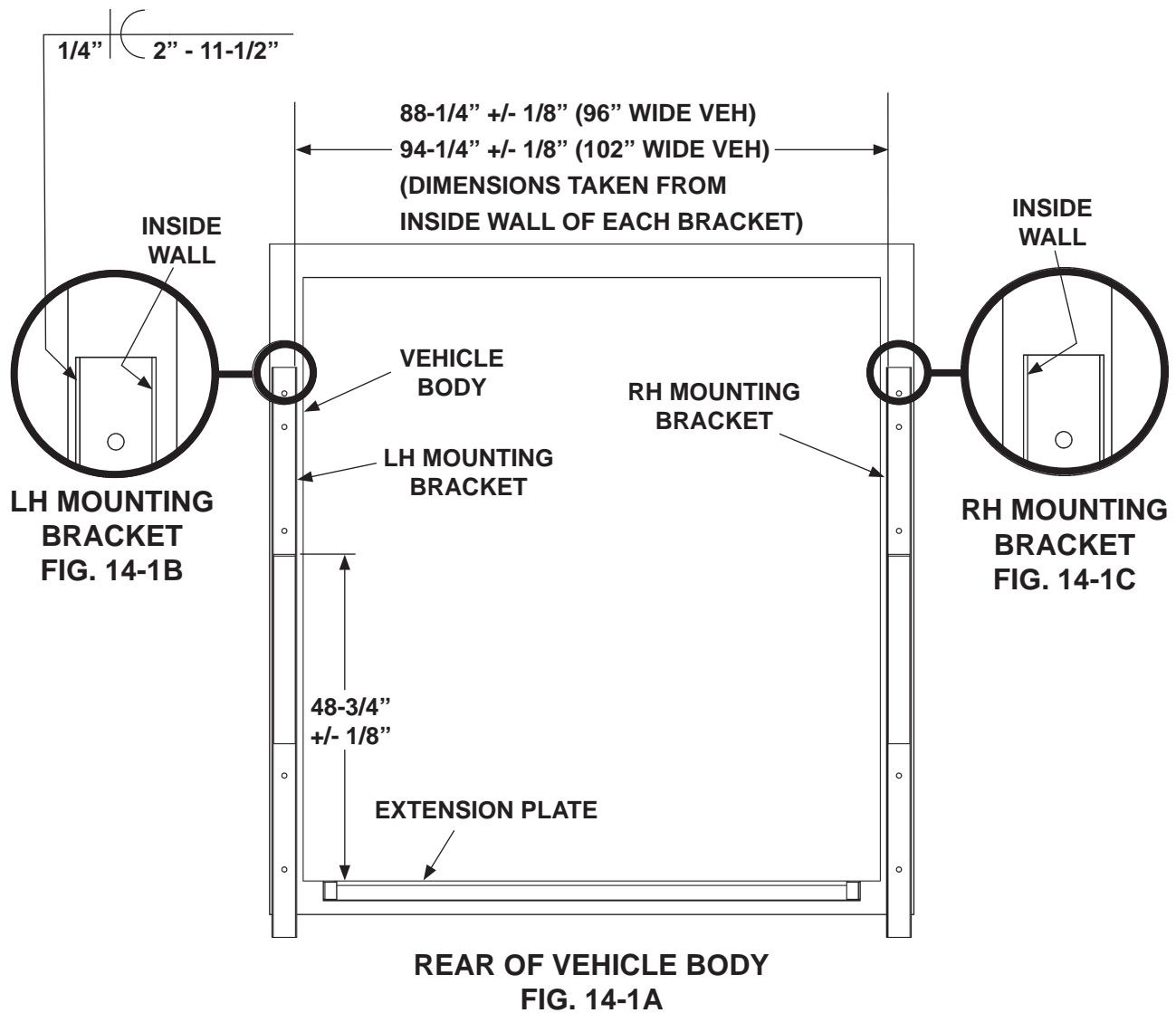

MAXON® 11921 Slauson Ave. Santa Fe Springs, CA. 90670 (800) 227-4116 FAX (888) 771-7713

STEP 2 - POSITION LIFTGATE - Continued

PRE-INSTALL MOUNTING BRACKETS AND EXTENSION PLATE - Continued

5. Weld the control box bracket to the vehicle body on the curbside of vehicle as shown in **FIG. 15-1**.

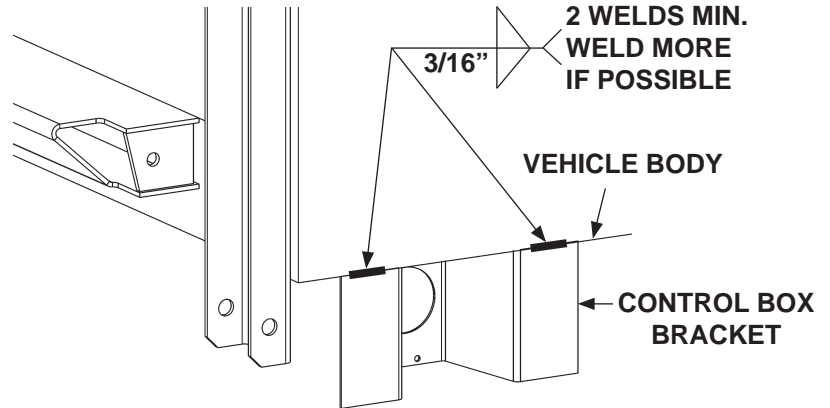

**WELDING CONTROL SWITCH
BRACKET TO VEHICLE BODY
FIG. 15-1**

STEP 2 - POSITION LIFTGATE - Continued

WELDING LIFTGATE TO BODY

⚠ WARNING

Recommended practices for welding on steel parts are contained in the current AWS (American Welding Society) D1.1 Structural Welding Code - Steel. Damage to Liftgate and/or vehicle, and personal injury can result from welds that are done incorrectly.

NOTE: With the following instructions, the column mounting brackets can be positioned on the vehicle body using the Liftgate as a positioning fixture.

NOTE: Before welding extension plate to vehicle body, make sure:

- Inboard edge of extension plate is flush with the top of sill on vehicle body.
- Top surface of extension plate is level with the ground.

CAUTION

Comply with welding CAUTION decals on the LH & RH runners.

! CAUTION !

When performing any electrical welding operations to the structure of this lift, be careful to connect the ground lead to the Liftgate component being welded (e.g. runner assembly, column assembly, platform assembly), and as close to the area being welded as possible. Because the separate assemblies on the BMR series lifts are insulated by self-lubricated bearings, failure to do so will cause severe damage to electrical components and metal parts.

CAUTION

To protect the original paint system, a 3" wide area of paint must be removed from all sides of the weld area before welding.

1. Weld 2 pieces of 10" x 2" angle stock to the top surface of the extension plate near the LH column as shown in **FIGS. 16-1A and 16-1B**. Repeat for RH column. The angle stock helps keep extension plate flush with top of vehicle bed while installing Liftgate.

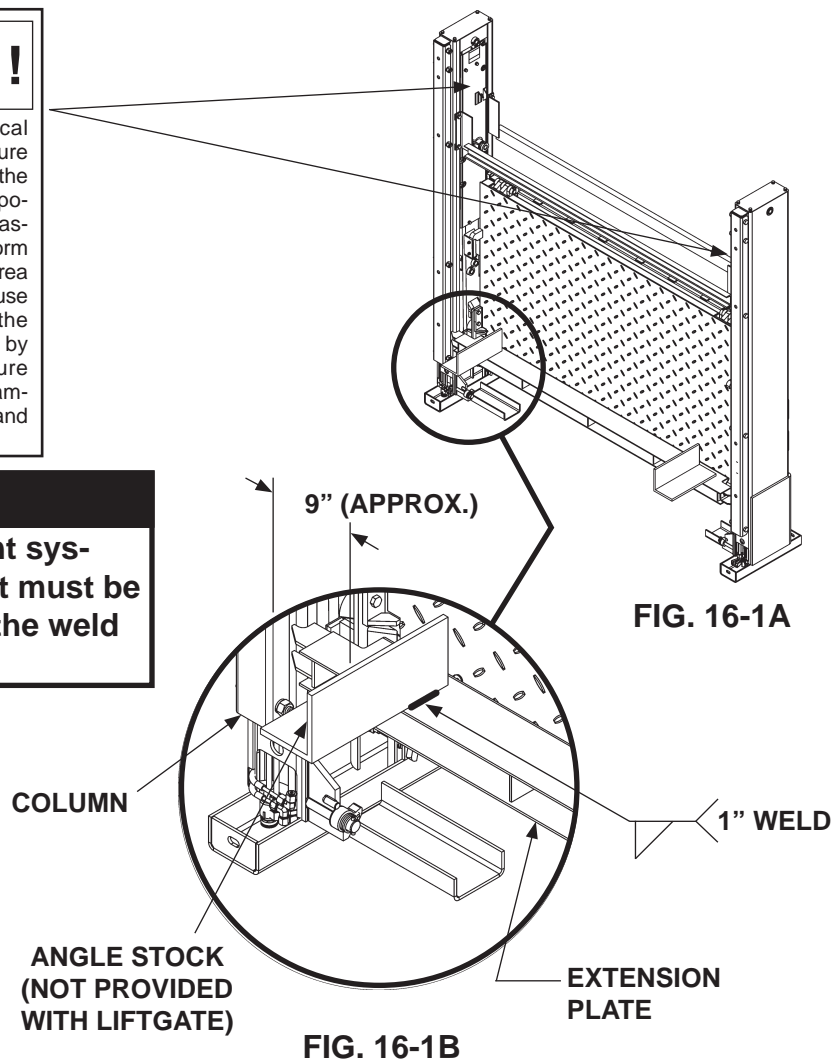

STEP 2 - POSITION LIFTGATE - Continued

WELDING LIFTGATE TO BODY - Continued

NOTE: There are 2 methods to weld Liftgate to vehicle body.

1. Weld the columns directly to vehicle body.
2. Weld mounting brackets to vehicle body (columns equipped with mounting brackets only).

2. Use overhead hoist or forklift to center Liftgate against the vehicle (**FIG. 17-1**). Let angle stock, welded to extension plate, rest on the top surface of the vehicle bed.
3. Clamp top of each column to vehicle body to prevent gap (**FIG. 17-1**).

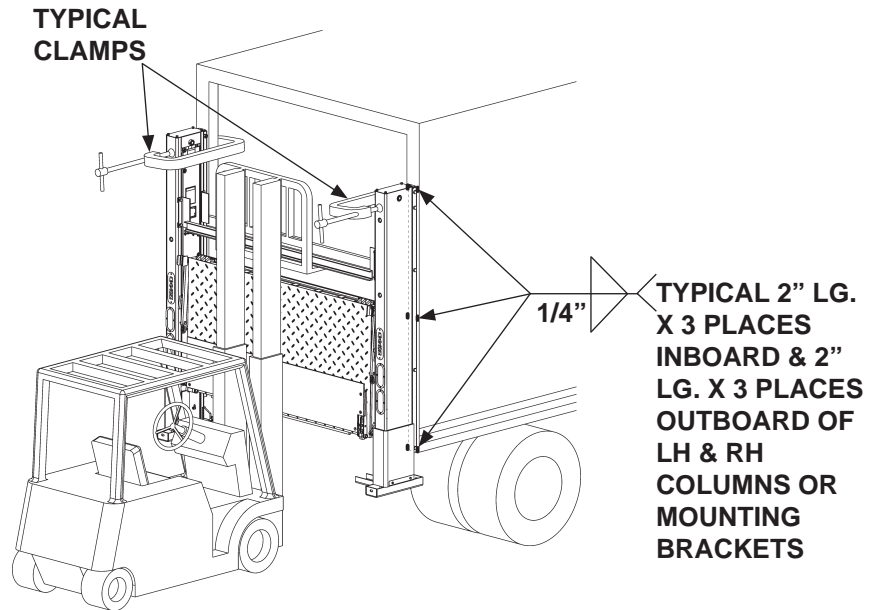

**MOUNTING BRACKET
OPTION SHOWN
FIG. 17-1**

CAUTION

To protect the original paint system, a 3" wide area of paint must be removed from all sides of the weld area before welding.

4. Weld the RH and LH columns or mounting brackets to vehicle body as shown in **FIG. 17-1**.

STEP 3 - BOLT LIFTGATE TO VEHICLE (IF REQUIRED)

1. Unbolt mounting brackets and extension plate from both columns (FIG. 18-1).

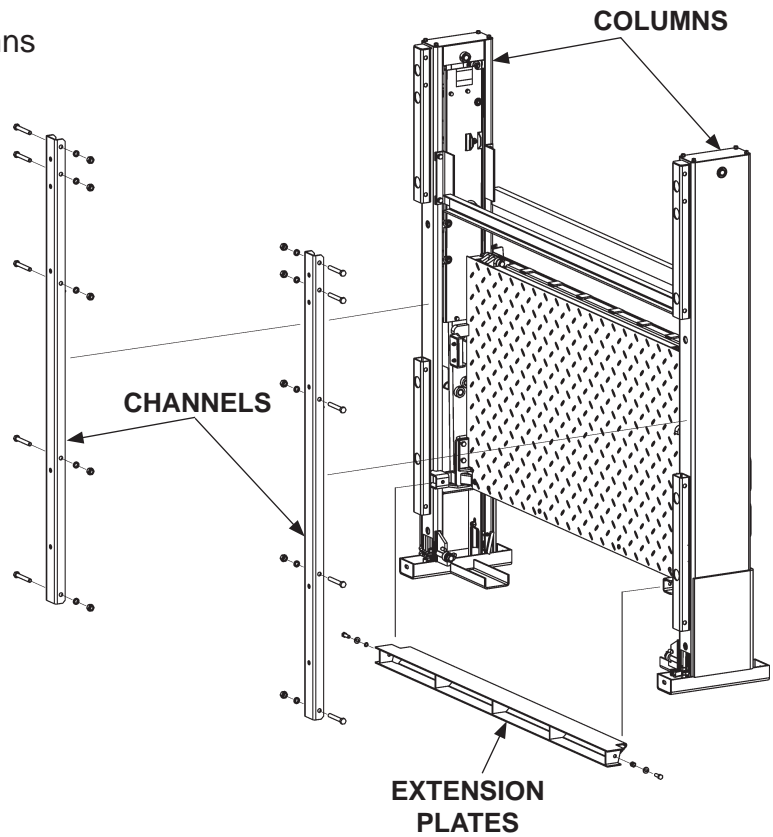

**UNBOLTING MOUNTING BRACKETS &
EXTENSION PLATE
FIG. 18-1**

STEP 3 - BOLT LIFTGATE TO VEHICLE (IF REQUIRED) - Continued

NOTE: Refer to **INSTALLED LIFTGATE** in the **VEHICLE REQUIREMENTS** section of this manual.

2. Use overhead hoist or forklift to position Liftgate on vehicle body. Line up the bracket on the RH column with the RH mounting bracket on the vehicle body (**FIG. 19-1**).
3. Make sure brackets, on LH column and LH side of vehicle body, are lined up (**FIG. 19-1**).

CAUTION

Ensure flange lock nuts are tight enough for flange to bottom against column brackets. Do not overtighten. Once installed, re-tightening is not required. If removed, replace the lock nuts with new flange lock nuts from MAXON. Never reuse the old nuts.

4. Mate the brackets on RH and LH sides of vehicle body. Next, bolt RH brackets together with the original bolts, flat washers (parts box item), and flange lock nuts (parts box item) (**FIG. 19-1**). Bolt the LH brackets together.

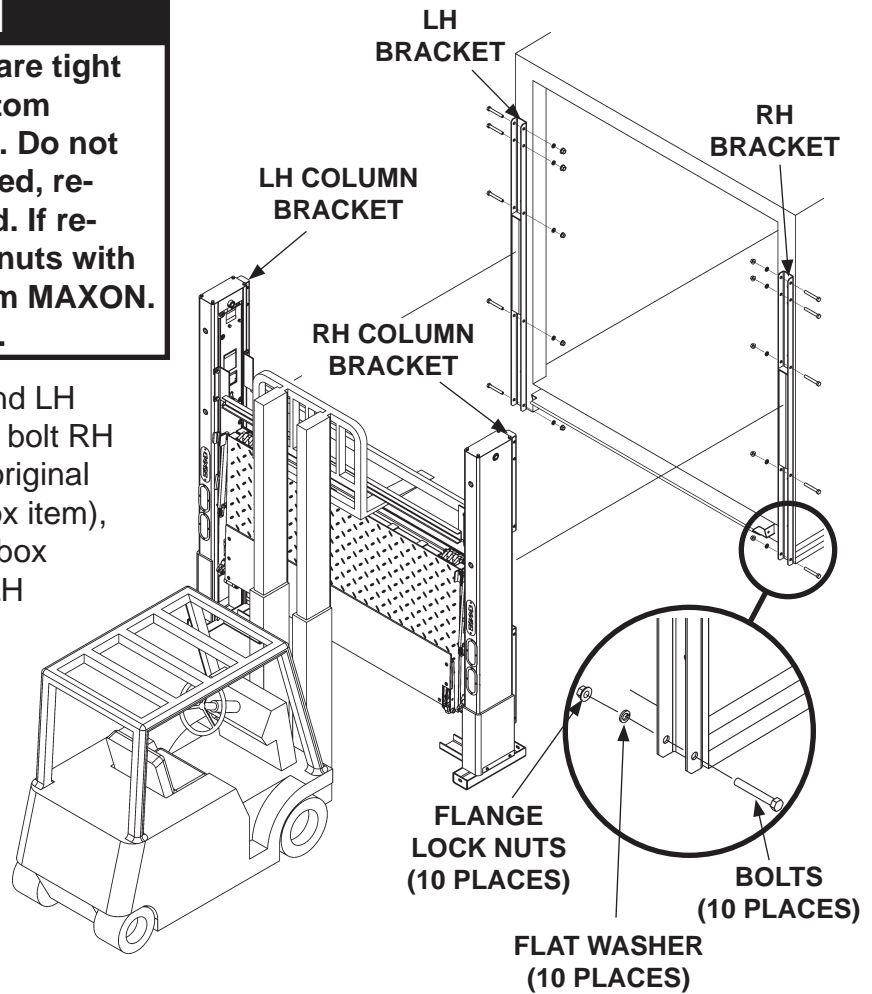
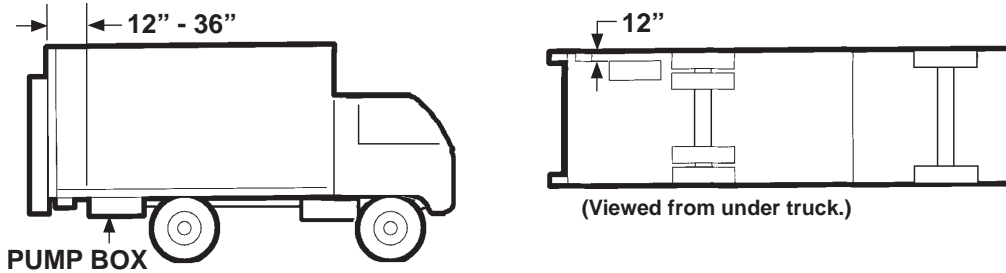

FIG. 19-1

STEP 4 - POSITION PUMP BOX FRAME

NOTE: Make sure pump box is closer to Liftgate than battery box (if installed) and pump box cover opens toward curb-side of vehicle. Also, make sure hydraulic hoses are installed without straining hoses. Distance from pump box to Liftgate is limited by lengths of hydraulic hoses and wiring harness supplied with Liftgate.

Position pump box frame (or optional battery box) on the ground where it will be welded to vehicle body in the next step. Make sure pump box (and battery box if supplied) are securely bolted to the frame. Typical installations are shown in **FIGS. 20-1, 20-2, 20-3 and 20-4.**



TYPICAL 3' FT. INSTALLATION

FIG. 20-1

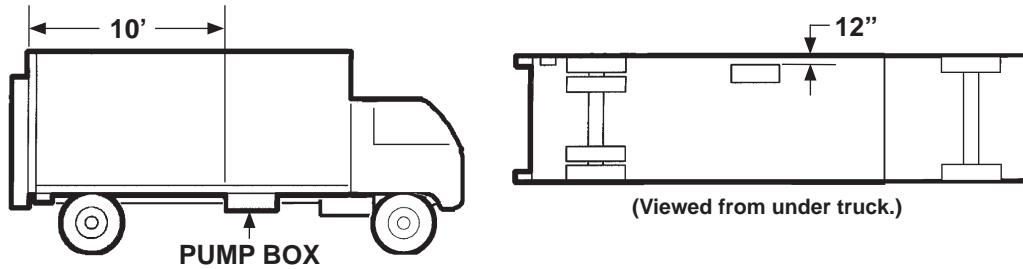

TYPICAL 10' FT. INSTALLATION

FIG. 20-2

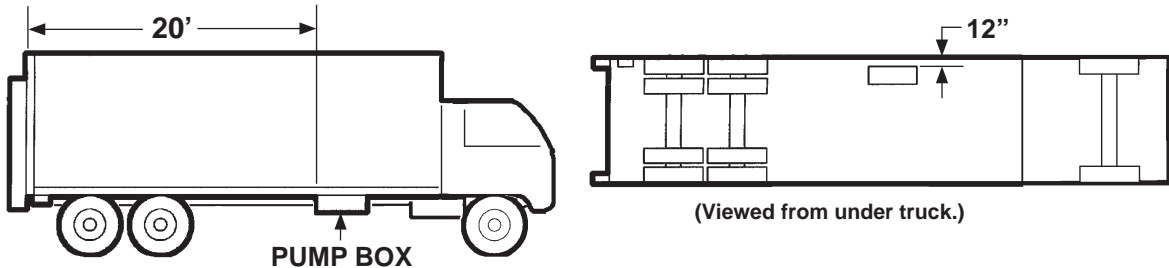

TYPICAL 20' FT. INSTALLATION

FIG. 20-3

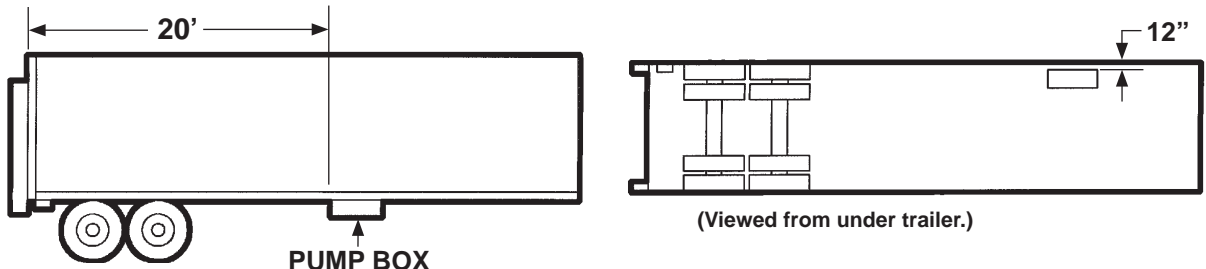

TYPICAL 20' FT. INSTALLATION

FIG. 20-4

STEP 5 - WELD PUMP BOX FRAME TO VEHICLE

⚠ WARNING

Recommended practices for welding on steel parts are contained in the current AWS (American Welding Society) D1.1 Structural Welding Code - Steel. Damage to Liftgate and/or vehicle, and personal injury can result from welds that are done incorrectly.

CAUTION

To prevent pump box components from being damaged by electric current from welding, connect welder grounding cable to the part being welded.

CAUTION

Cover pump box and optional battery box with flame-resistant covering before welding pump box frame to vehicle.

NOTE: If possible, position 2 of the angle supports pointing in opposite direction from the other angle supports (**FIG. 21-1B**).

1. Use floorjack or equivalent lifting device to place pump box frame in position on vehicle body cross members as shown in **FIGS. 21-1A and 21-1B**.

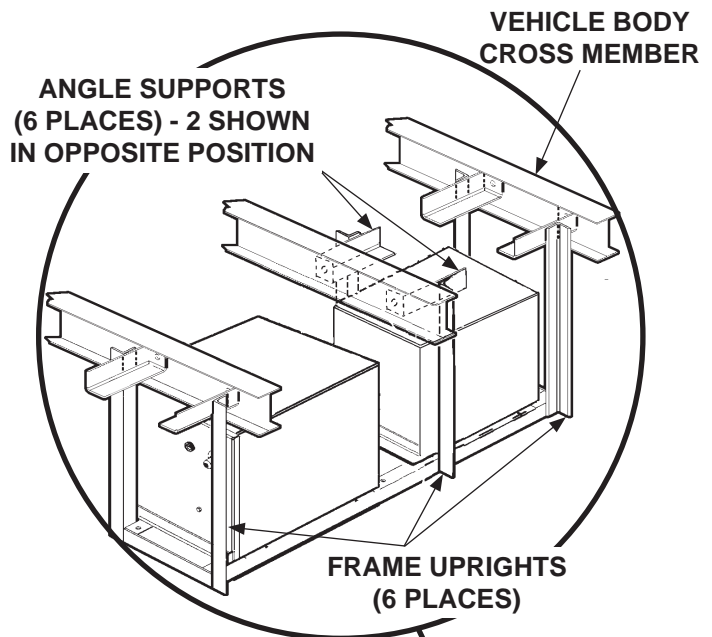
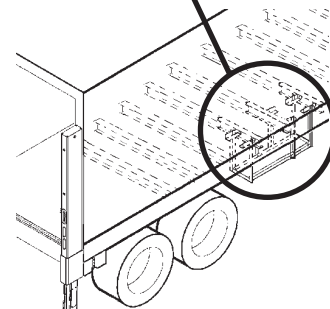

FIG. 21-1B



TRAILER WITH PUMP & BATTERY BOX FRAME
FIG. 21-1A

STEP 5 - WELD PUMP BOX FRAME TO VEHICLE - Continued

2. Make sure angle supports are centered between top and bottom of cross member. Position each of the frame uprights by the nearest cross member (**FIG. 22-1A**).

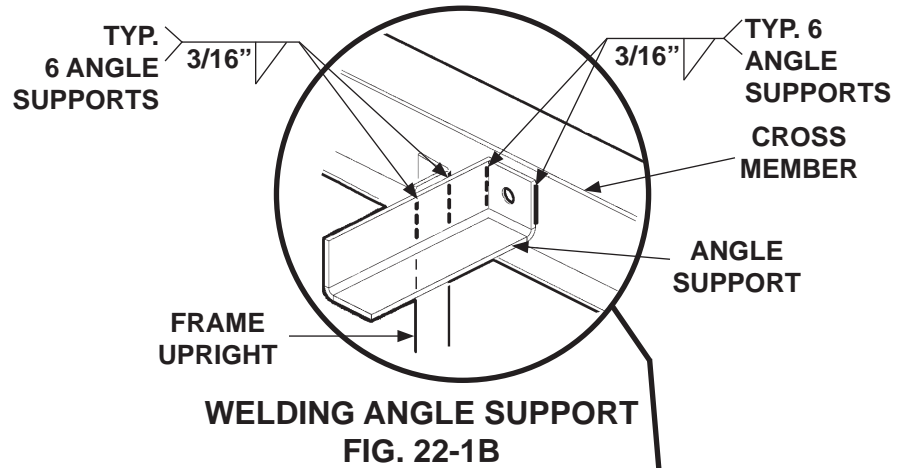

CAUTION

To protect the original paint system, a 3" wide area of paint must be removed from all sides of the weld area before welding.

NOTE: If vehicle body has aluminum cross members, skip instruction 3.

3. If vehicle body has steel cross members, clamp and weld each angle support to cross member (**FIG. 22-1B**). Then, clamp and weld each frame upright to angle support (**FIG. 22-1B**).

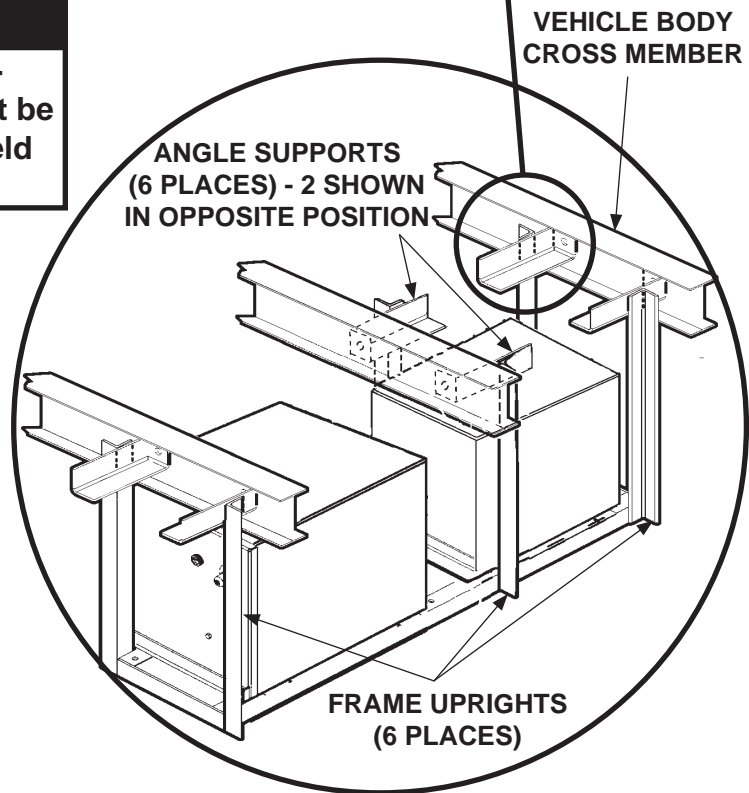

STEP 5 - WELD PUMP BOX FRAME TO VEHICLE - Continued

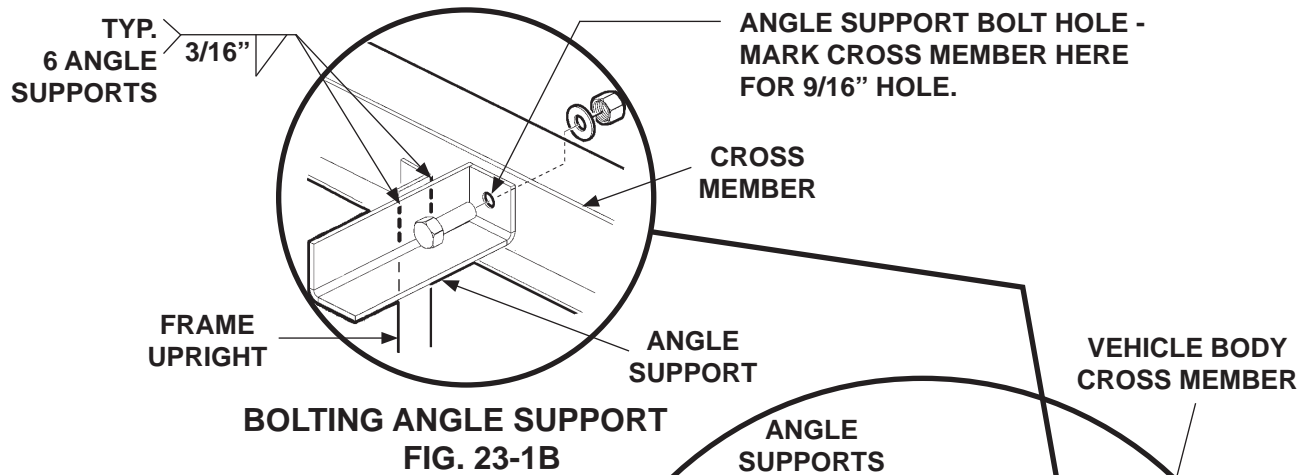

**BOLTING ANGLE SUPPORT
FIG. 23-1B**

NOTE: If angle supports were welded to steel cross members (**instruction 3**), **STEP 5** is complete. Skip **instructions 4-7**.

4. If vehicle body has aluminum cross members, mark hole position on cross member for each angle support (**FIG. 23-1B**) lower pump box frame. Drill 9/16" hole at each marking.

5. Lift pump box frame back into correct position (**FIG. 23-1A**).

6. Bolt each angle support to aluminum cross member as shown in **FIG. 23-1B**.

7. Weld each frame upright to angle support as shown in **FIG. 23-1B**.

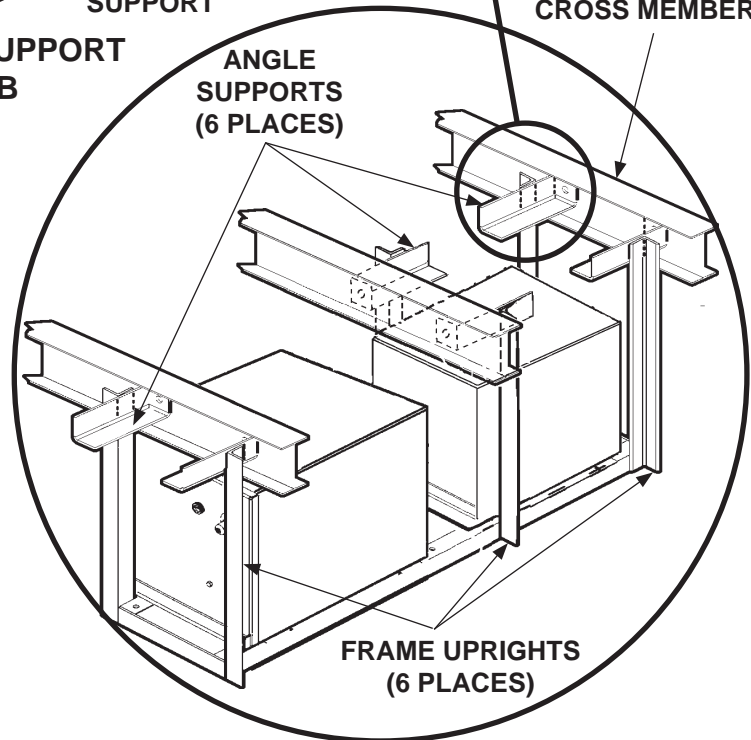

FIG. 23-1A

STEP 6 - RUN HYDRAULIC LINES & ELECTRIC CABLES

CAUTION

Always route hydraulic hoses and electrical wiring clear of moving parts, brake lines, sharp edges and exhaust systems. Avoid making sharp bends in hoses and wiring. Make sure that bends in the electrical wiring are 1" or more away from electrical connector. Attach securely. If drilling is necessary, first check behind the drilling surface so you do not damage any fuel lines, vent lines, brake lines or wires.

NOTE: The hydraulic cylinders in the Liftgate are filled with hydraulic fluid and bled at the factory. To keep air out of the hydraulic system, follow instructions carefully for installing hydraulic system components.

1. Get hydraulic hoses, hydraulic tee, channel guard (if required) and plastic ties from part box and pump box installation kit. Run hydraulic hoses from LH and RH columns to pump box. Connect hydraulic hoses as shown in **FIG. 25-1** and **TABLE 25-1**.
2. Get molded interconnecting harness and molded extension cable from pump box installation kit. Run the molded interconnecting harness and molded extension cable from LH and RH columns to pump box as shown in **FIG. 26-1**.
3. If channel guard is required, bolt up one side of the channel (**FIGS. 25-1 and 26-1**) to vehicle body. Leave bolts loose until all hydraulic hoses (**FIG. 25-1**) and wiring harness (**FIG. 26-1**) are run through channel. After hoses and wiring harness are run, bolt up second side of channel and tighten all bolts and nuts. Use plastic ties to secure runs of hydraulic hoses and wiring harness that are outside of channel guard.

STEP 6 - RUN HYDRAULIC LINES & ELECTRIC CABLES

- Continued

RUN HYDRAULIC LINES

NOTE: See TABLE 25-1 for information on the numbered hoses in this illustration.

CAUTION
Before connecting hoses, ensure face seal o-rings are in place.

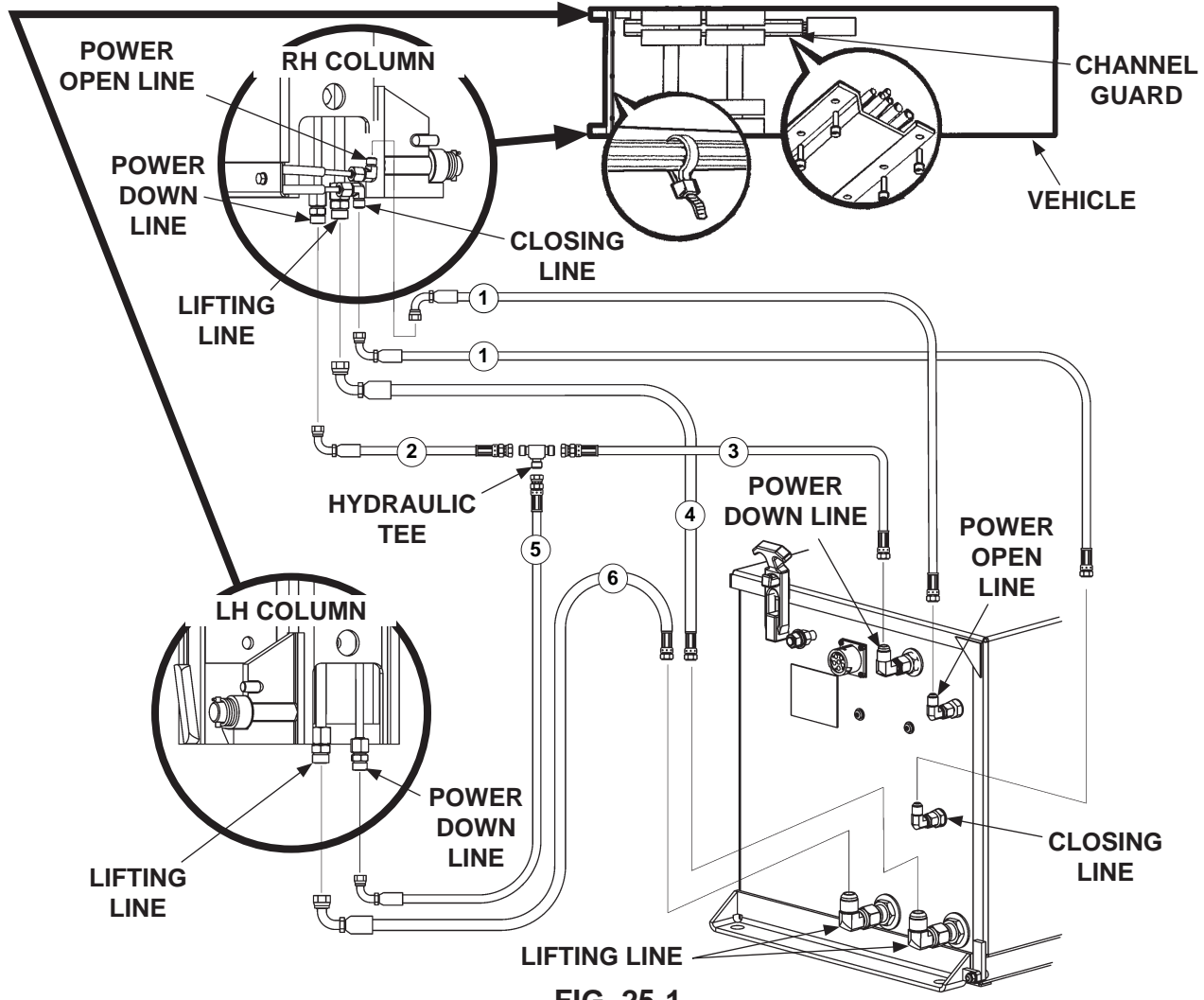

FIG. 25-1

PUMP BOX INSTALLATION: REQUIRED HOSES			
	3 FT.	10 FT.	20 FT.
1	HP 1/4" X 56" LG.	HP 1/4" X 188" LG.	HP 1/4" X 308" LG.
2		HP 1/4" X 24" LG.	
3	HP 1/4" X 34" LG.	HP 1/4" X 166" LG.	HP 1/4" X 286" LG.
4	HP 3/8" X 64" LG.	HP 3/8" X 196" LG.	HP 3/8" X 316" LG.
5		HP 1/4" X 100" LG.	
6	HP 3/8" X 142" LG.	HP 3/8" X 274" LG.	HP 3/8" X 394" LG.

TABLE 25-1

11921 Slauson Ave. Santa Fe Springs, CA. 90670 (800) 227-4116 FAX (888) 771-7713
MAXON

STEP 6 - RUN HYDRAULIC LINES & ELECTRIC CABLES - Continued RUN ELECTRIC CABLES

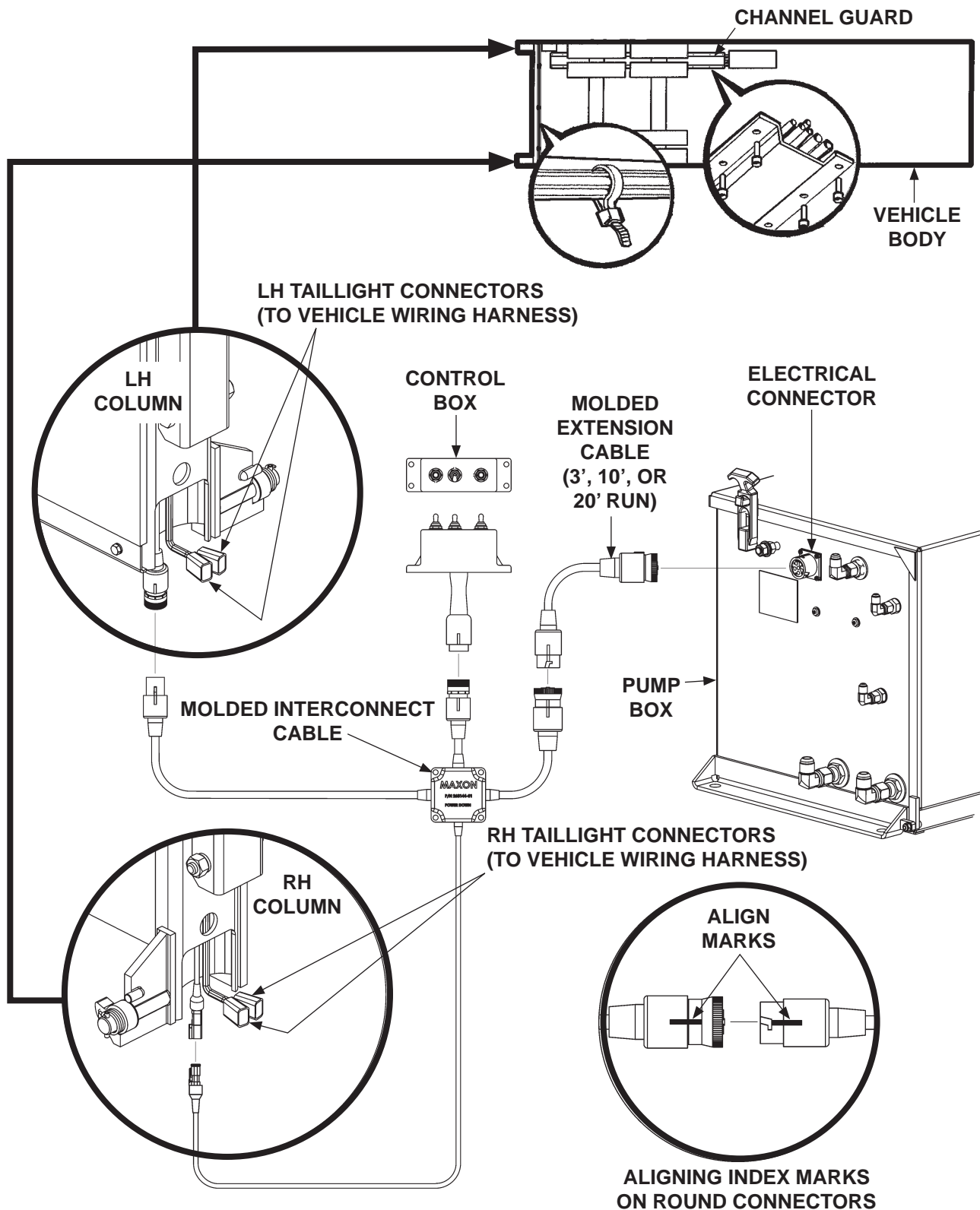

FIG. 26-1

11921 Slauson Ave. Santa Fe Springs, CA. 90670 (800) 227-4116 FAX (888) 771-7713
MAXON

STEP 7 - CONNECT GROUND CABLE

GROUNDING TO TRUCK FRAME

NOTE: Make sure the Liftgate power unit, all batteries on the vehicle for power unit, and taillights on Liftgate are connected correctly to a common ground.

1. Bolt ground cable to the ground stud on pump box (**FIG. 27-1A**).

NOTE: If there is an existing grounding point on truck frame, use it to connect ground cable and skip the step for drilling a hole.

2. Extend the ground cable to reach vehicle frame (**FIG. 27-1C**) without putting tension on cable (after connection). Connect to an existing grounding point if available.
3. If necessary, drill a 11/32" (0.343") hole in vehicle frame for bolting the ground cable terminal lug (**FIG. 27-1C**).

NOTE: Clean the ground cable connection point on the frame down to bare metal.

NOTE: MAXON recommends using dielectric grease on all electrical connections.

4. Bolt the ground cable terminal lug to vehicle frame as shown in **FIG. 27-1C**.

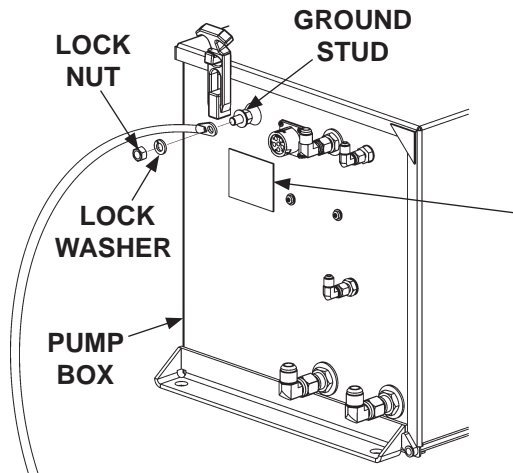

FIG. 27-1A

GROUND STUD
CONNECT GROUND CABLE BEFORE OPERATING LIFTGATE. SEE INSTALLATION MANUAL FOR INSTRUCTIONS.
P/N 765734-01

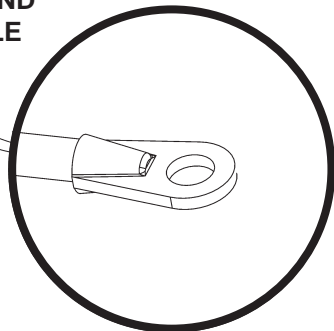

FIG. 27-1B

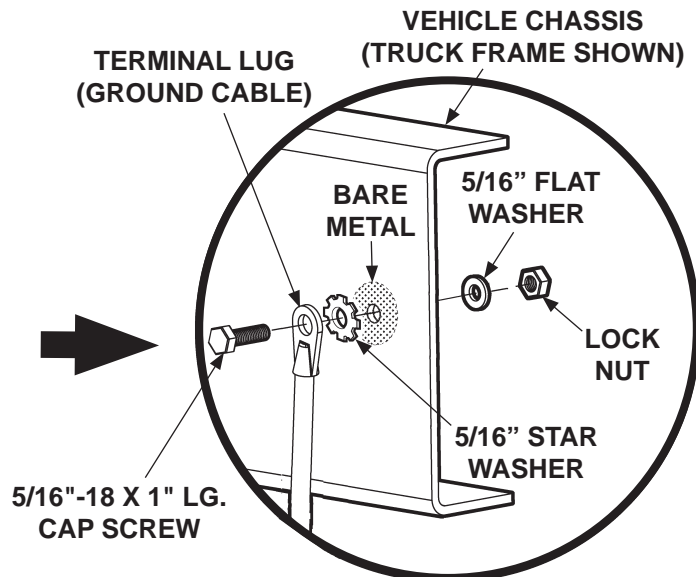

FIG. 27-1C

STEP 7 - CONNECT GROUND CABLE - Continued

GROUNDING TO BATTERY BOX (IF EQUIPPED)

NOTE: Make sure the Liftgate power unit, battery box and batteries, taillights on Liftgate, and vehicle charging system are connected correctly to a common ground. For trailers, if possible, use 2-pole charge line to connect charging system on tractor to the Liftgate batteries.

1. Attach ground cable to ground stud outside the pump box (**FIG. 28-1**). Tighten lock nut.

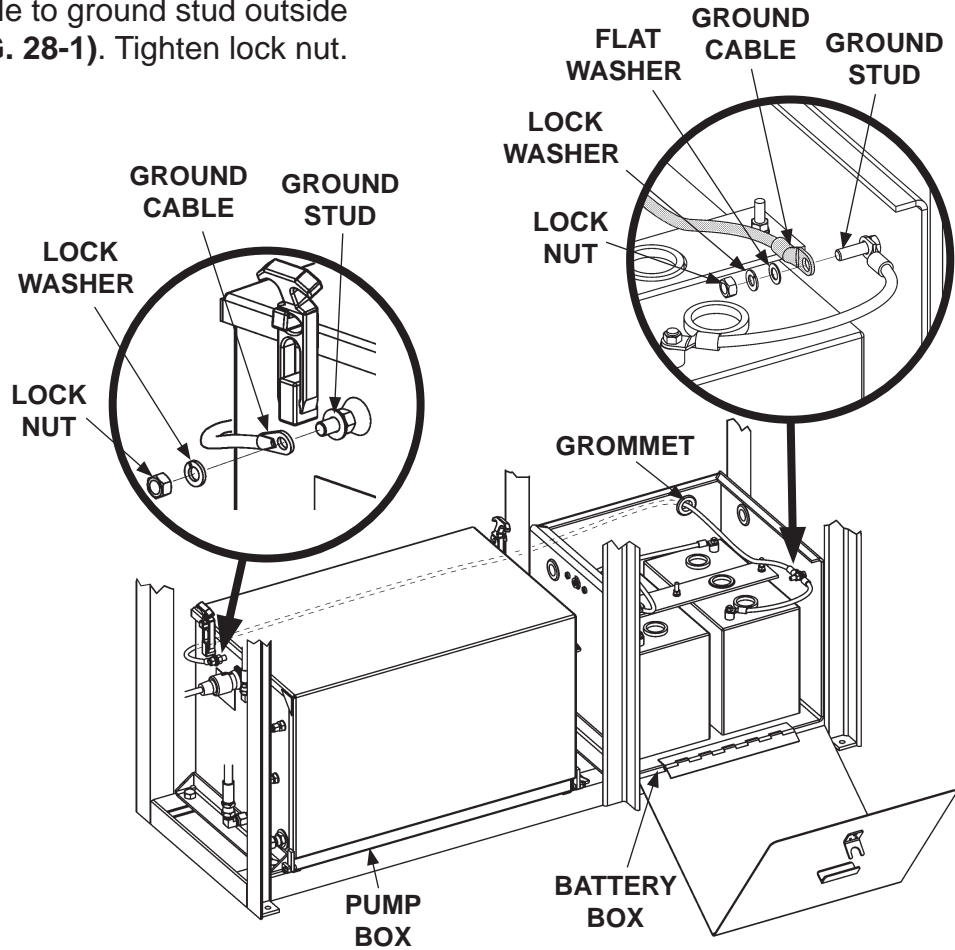

FIG. 28-1

2. Route ground cable behind pump box and battery box to the grommet on the back wall of battery box (**FIG. 28-1**). Then, pull ground cable through grommet to the ground stud (**FIG. 28-1**).

NOTE: Ensure the ground stud in battery box is connected by cable to common ground on vehicle.

3. Attach ground cable to battery box ground stud (**FIG. 28-1**). Tighten lock nut.

STEP 8 - INSTALL CONTROL BOX & BRACKET

⚠ WARNING

Recommended practices for welding on steel parts are contained in the current AWS (American Welding Society) D1.1 Structural Welding Code - Steel. Damage to Liftgate and/or vehicle, and personal injury can result from welds that are done incorrectly.

CAUTION

Prevent damage to control box. Make sure installed control box does not protrude out from the side of vehicle body.

CAUTION

To protect the original paint system, a 3" wide area of paint must be removed from all sides of the weld area before welding.

NOTE: If control box bracket is already installed, skip instruction 1.

1. Weld the control box bracket (parts box item) under the vehicle body on the curb-side of vehicle as shown in FIGS. 29-1A and 29-1B.

2. Bolt control box to bracket (FIG. 29-1A).

3. If Liftgate comes with remote hand-held control kit, install hand-held control according to **Instruction Sheet** contained in kit.

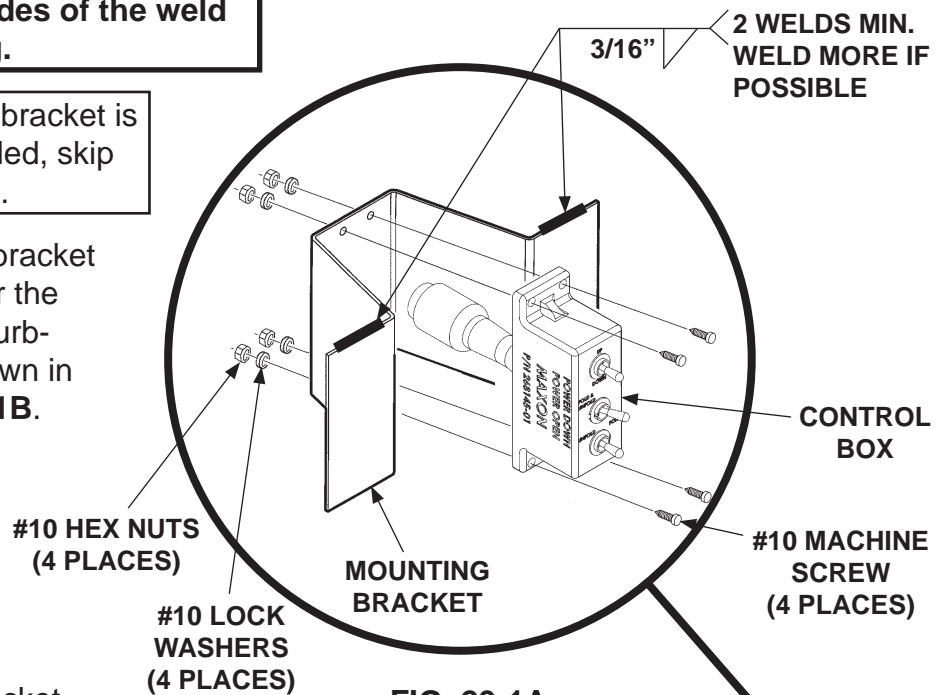

FIG. 29-1A

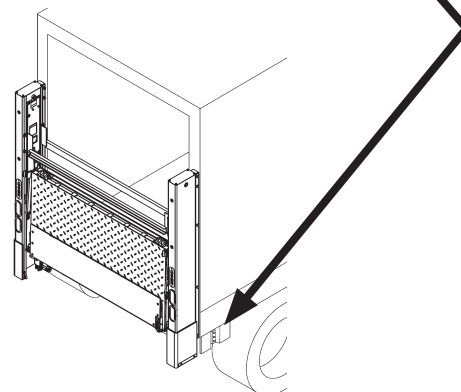

FIG. 29-1B

STEP 9 - RUN CHARGE LINES

⚠ CAUTION

Never route an energized wire. Make sure battery is disconnected. Always route electrical wires clear of moving parts, brake lines, sharp edges and exhaust systems. Avoid making sharp bends in wiring. Attach securely. If drilling is necessary, first check behind the drilling surface so you do not damage any fuel lines, vent lines, brake lines or wires.

NOTE: Make sure cable is long enough to reach master disconnect switch on Liftgate pump box (or circuit breaker in optional battery box, if installed) without putting tension on the cable.

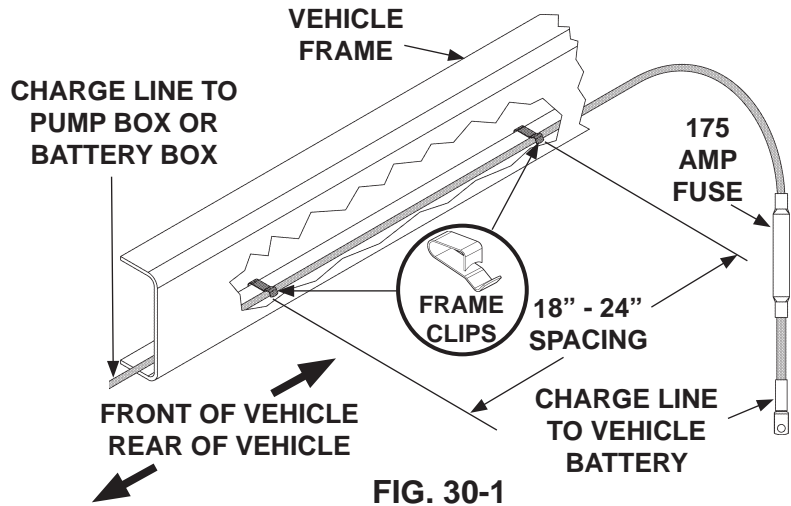

FIG. 30-1

1. Install vehicle charge line by running the line along the inside of vehicle frame (FIG. 30-1). Make sure 175 amp fuse (FIG. 30-1) end of cable is by the battery. Run the charge line from vehicle battery to Liftgate pump box master disconnect switch (FIG. 30-2) or circuit breaker in an optional battery box (FIG. 30-3), if installed. Use frame clips (parts box item) and plastic ties (as required) from charge line kit to secure cable.

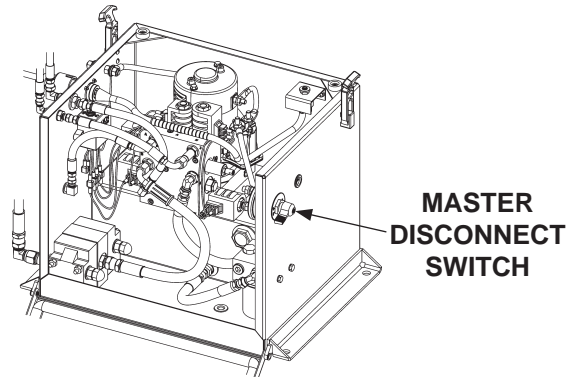

FIG. 30-2

2. If Liftgate comes with:

- Single Pole Tractor Charge Line Kit
- Single Pole Trailer Charge Line Kit
- Dual Pole Tractor Charge Line Kit
- Dual Pole Trailer Charge Line Kit

Install charge line according to **Instruction Sheet** contained in each kit.

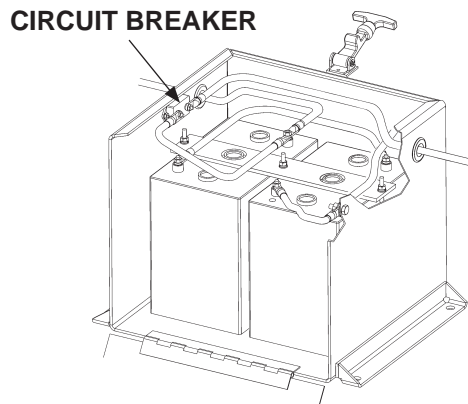

FIG. 30-3

STEP 10 - CONNECT BATTERIES TO LIFTGATE

⚠ WARNING

To prevent injury and equipment damage, make sure (-) battery cable is disconnected and master disconnect switch is in the OFF position before connecting vehicle charge lines or power cables.

NOTE: For recommended 6 volt and 12 volt battery connections, refer to the **RECOMMENDED LIFTGATE POWER CONFIGURATION** section in this manual.

1. Disconnect (-) battery cable (FIG. 31-1) from battery.

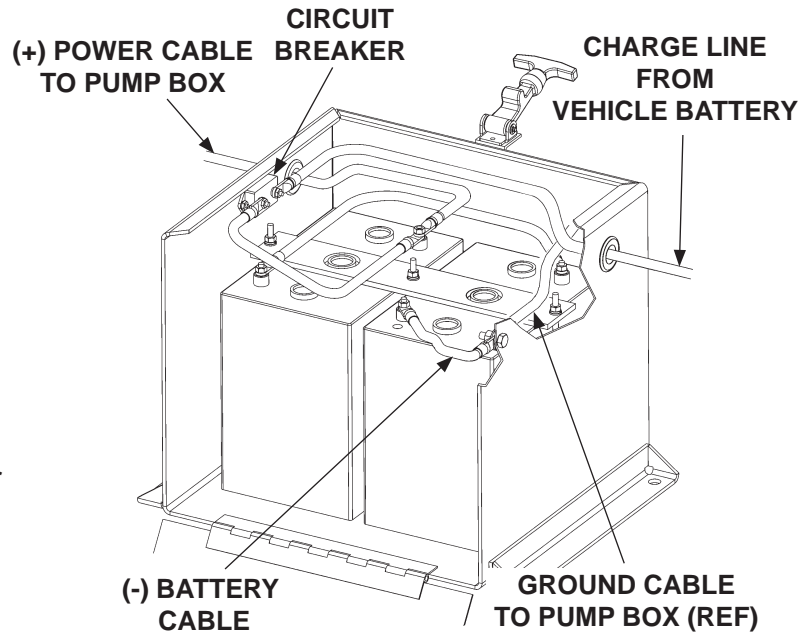

**BATTERY BOX
(6 VOLT BATTERIES SHOWN)
FIG. 31-1**

2. Connect vehicle charge line to unconnected terminal on master disconnect switch (FIG. 31-2).

NOTE: After battery cables are connected, ensure pump box cover and battery box cover (if equipped) are closed.

3. If optional battery box (FIG. 31-1) is installed, connect (+) power cable from battery box to master switch in the pump box (FIG. 31-2). Then, connect vehicle charge line to circuit breaker in optional battery box (FIG. 31-1).

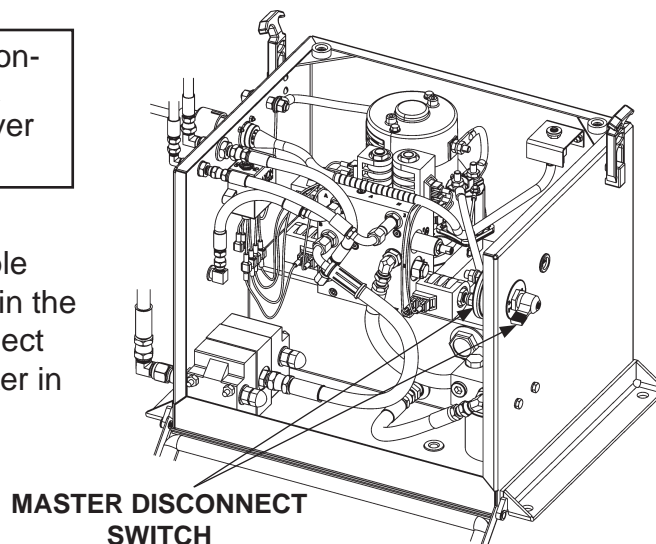

**PUMP BOX
FIG. 31-2**

STEP 11 - ADD HYDRAULIC FLUID TO RESERVOIR

CAUTION

Keep dirt, water and other contaminants from entering the hydraulic system. Before opening the hydraulic fluid reservoir filler cap, drain plug and hydraulic lines, clean up contaminants that can get in the openings. Also, protect the openings from accidental contamination.

1. Open pump box cover (**FIG. 32-1**).

2. Remove the filler cap (**FIG. 32-1**).
Add **4 quarts** (single pump) or **6 quarts** (dual pump) of hydraulic fluid to pump reservoir.

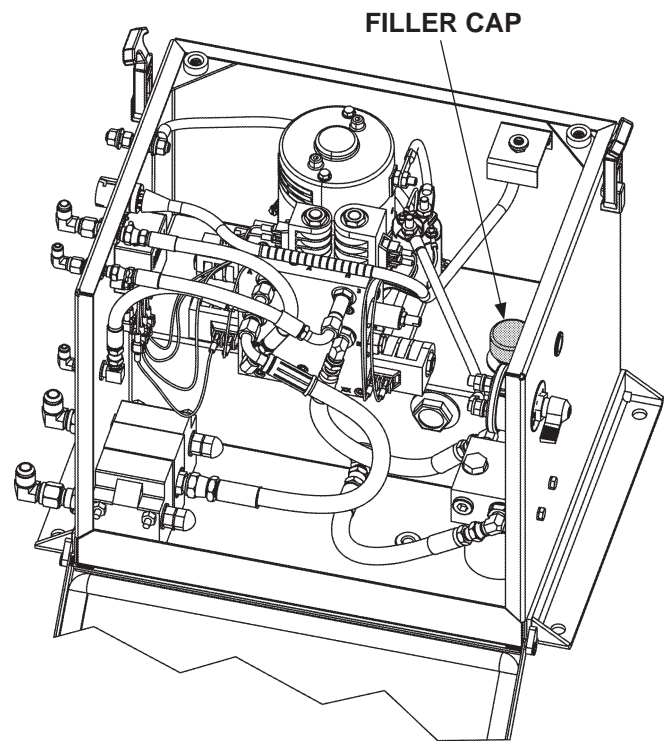

**PUMP BOX SHOWN WITH SINGLE PUMP
FIG. 32-1**

3. Reinstall the filler cap (**FIG. 32-1**).

STEP 12 - PRESSURIZE HYDRAULIC SYSTEM

⚠ WARNING

To prevent injury and equipment damage, pressurize hydraulic system before removing lower support fixtures and operating Liftgate.

1. To pressurize lifting cylinders, set control box toggle switch to **UP** for 10-15 seconds as shown in **FIG. 33-1**.

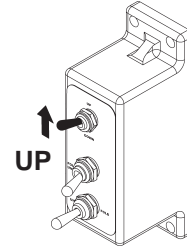

CONTROL BOX
FIG. 33-1

2. To pressurize closing cylinder, set control box toggle switches to **FOLD** for 10-15 seconds as shown in **FIG. 33-2**.

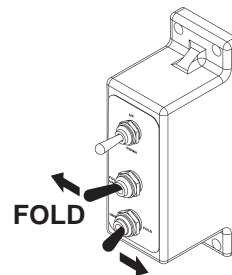

CONTROL BOX
FIG. 33-2

NOTE: Liftgate is shipped with **ISO 32** hydraulic fluid in the hydraulic cylinders. For operation in **severe cold weather**, refer to the **CHANGING HYDRAULIC FLUID** procedure in the **BMRSD Maintenance Manual**. If necessary, change to the recommended grade of hydraulic fluid.

STEP 13 - REMOVE LOWER SUPPORT FIXTURE

NOTE: Use short wrenches for unbolting lower support fixtures.

Unbolt lower support fixture (**FIG. 34-1A**) from LH column (**FIG. 34-1B**). Repeat for lower support fixture on RH column (**FIG. 34-1B**).

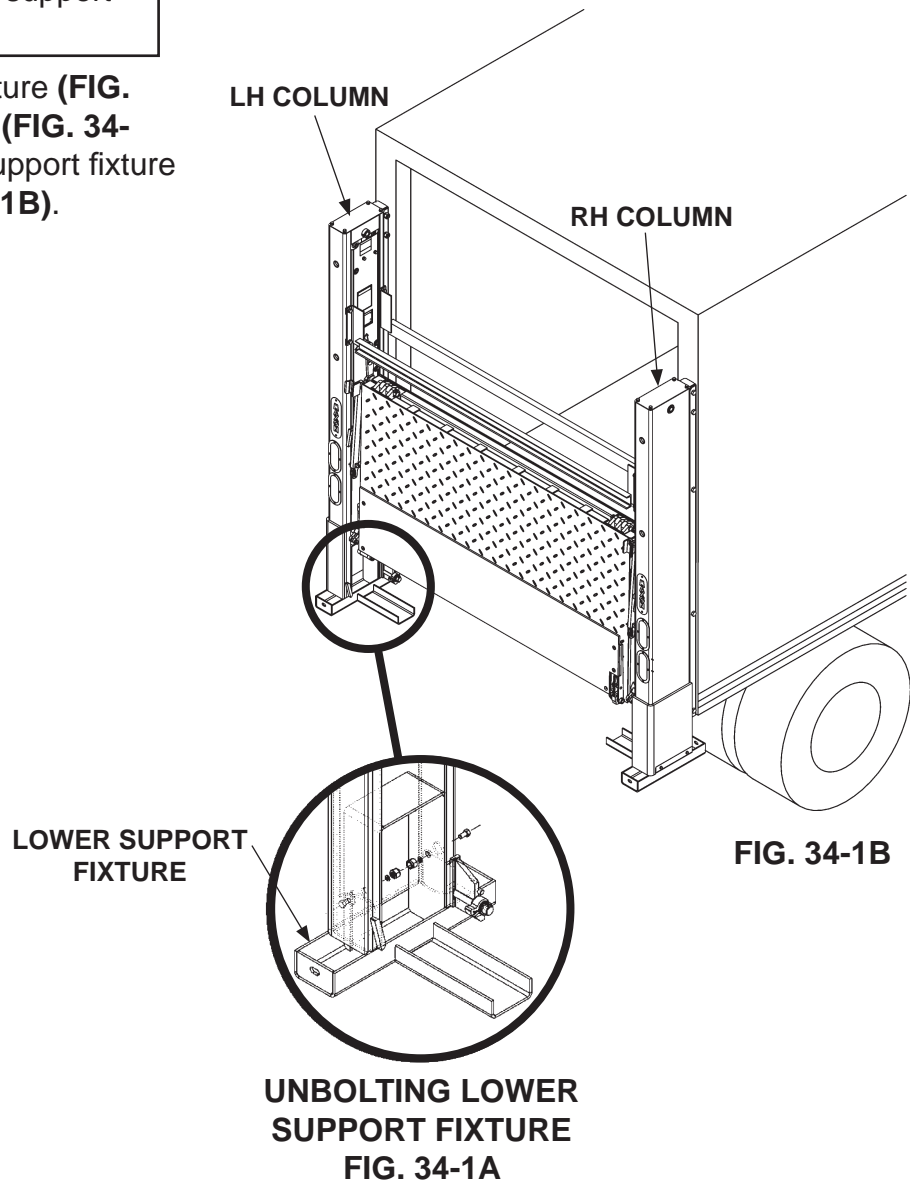

STEP 14 - OPTIMIZE HYDRAULIC FLUID LEVEL

1. Put power down on demand switch in PD position (**FIG. 35-1**).

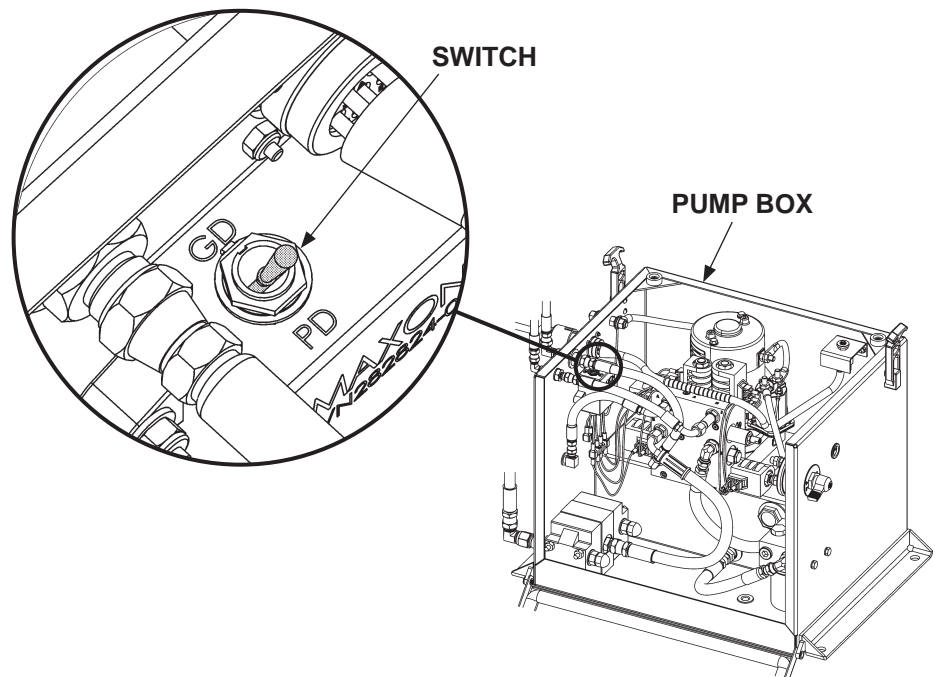

**SWITCHING PUMP TO GRAVITY DOWN OPERATION
FIG. 35-1**

2. Next, lower (**DOWN**) the platform about 6" using toggle switch settings shown in **FIG. 35-2**.

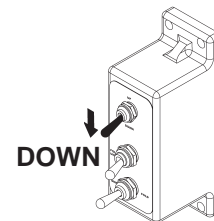

FIG. 35-2

3. Open (**UNFOLD**) the platform by setting toggle switches as shown in **FIG. 35-3**.

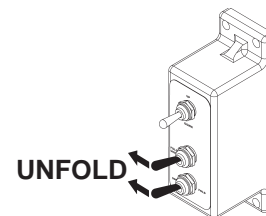

FIG. 35-3

STEP 14 - OPTIMIZE HYDRAULIC FLUID LEVEL - Continued

4. Close (**FOLD**) the platform by setting toggle switches as shown in **FIG. 36-1**. Then, open (**UNFOLD**) the platform by setting toggle switches as shown in **FIG. 36-2**.

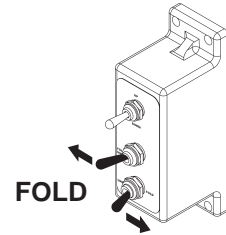

FIG. 36-1

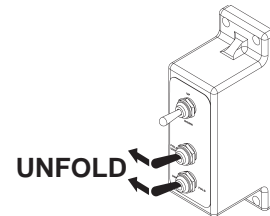

FIG. 36-2

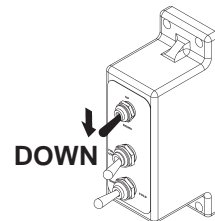

FIG. 36-3

5. Lower (**DOWN**) the platform (**FIG. 36-4**) to ground level using the toggle switch settings shown in **FIG. 36-3**.

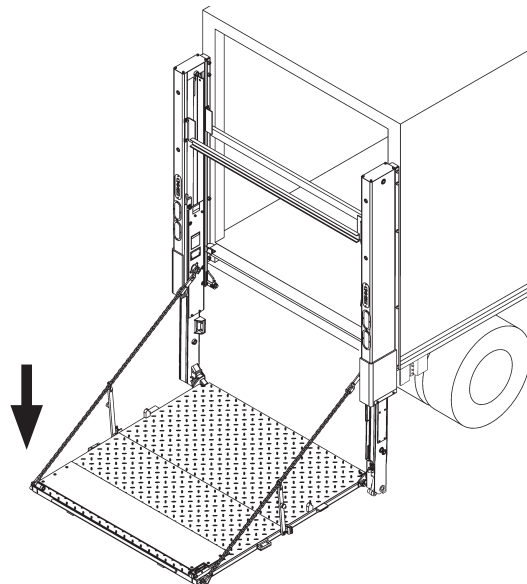

FIG. 36-4

STEP 14 - OPTIMIZE HYDRAULIC FLUID LEVEL - Continued

6. Raise **(UP)** the platform to bed height using toggle switch setting shown in **FIG. 37-1**.

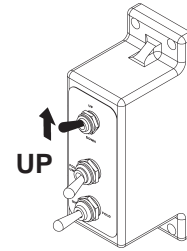
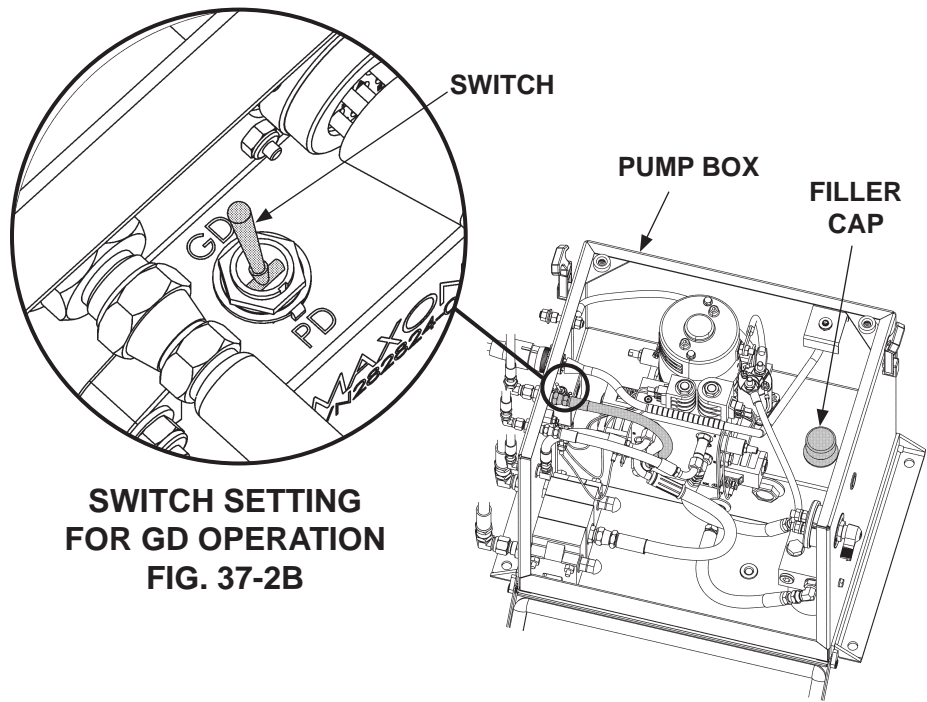

FIG. 37-1

7. Switch power down on demand switch to GD position (**FIG. 37-2B**). Then, lower **(DOWN)** platform to the ground (**FIG. 36-4**).



**SWITCH SETTING
FOR GD OPERATION
FIG. 37-2B**

FIG. 37-2A

8. Check if hydraulic fluid level is at the middle of sight glass (**FIG. 37-3**). If necessary, remove filler cap (**FIG. 37-2A**) and add hydraulic fluid until level rises to middle of sight glass (**FIG. 37-3**). Then, reinstall filler cap (**FIG. 37-2A**).

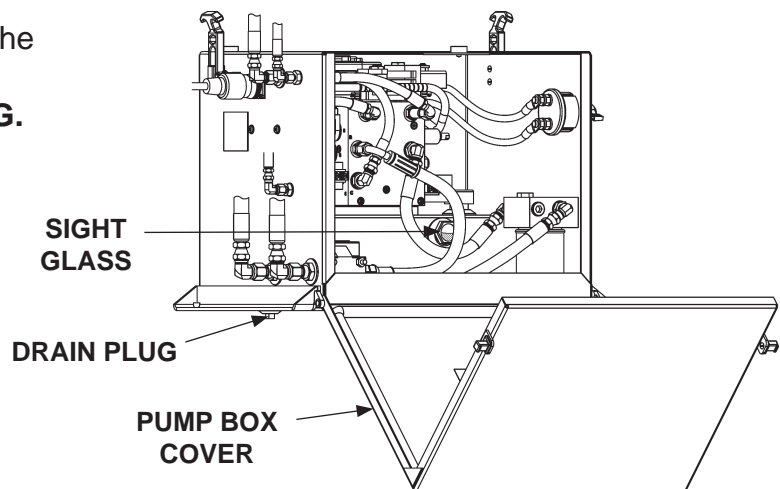

**PUMP BOX COVER OPENED FOR ACCESS
FIG. 37-3**

STEP 15 - FINISH WELDING LIFTGATE TO VEHICLE

⚠ WARNING

Recommended practices for welding on steel parts are contained in the current AWS (American Welding Society) D1.1 Structural Welding Code - Steel. Damage to Liftgate and/or vehicle, and personal injury can result from welds that are done incorrectly.

NOTE: Refer to **INSTALLED LIFTGATE** in the **VEHICLE REQUIREMENTS** section of this manual.

NOTE: There are 2 methods of welding the Liftgate to vehicle body: 1.) Weld mounting brackets (if equipped) to body or 2.) weld columns directly to body.

NOTE: If the Liftgate was used as a fixture to position the column mounting brackets and those brackets are mild steel, the Liftgate must be removed to paint the brackets. Remove the Liftgate only after the brackets are welded to vehicle.

CAUTION

Some mild steel Liftgate mounting channels and extension plates are coated with a protective film and shipped unpainted. The film, if not removed for painting, can cause paint to separate from surface. Use a suitable solvent to remove the protective film before painting.

NOTE: To remove protective film from unpainted mounting channels and extension plate, use a solvent such as Houghton-Clean 221 or Certa-Kleen S-7 or S-8.

1. Remove nut from positive (+) battery terminal connector. Disconnect power cable from the positive (+) battery terminal connector (**FIG. 38-1**).

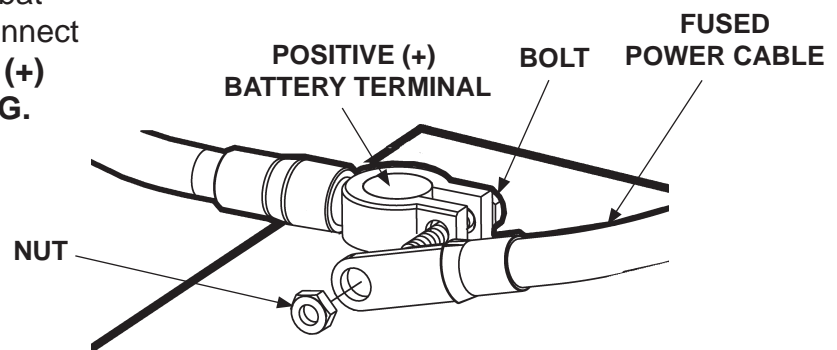

DISCONNECTING FUSED POWER CABLE
FIG. 38-1

STEP 15 - FINISH WELDING LIFTGATE TO VEHICLE - Continued

CAUTION

To prevent damage to Liftgate, connect welder ground to vehicle body.

⚠ WARNING

Do not remove support fixtures before welding.

2. Cover platform as shown in FIG. 39-1.

3. Weld the Liftgate RH and LH columns or mounting brackets to vehicle body as shown in FIG. 39-1.

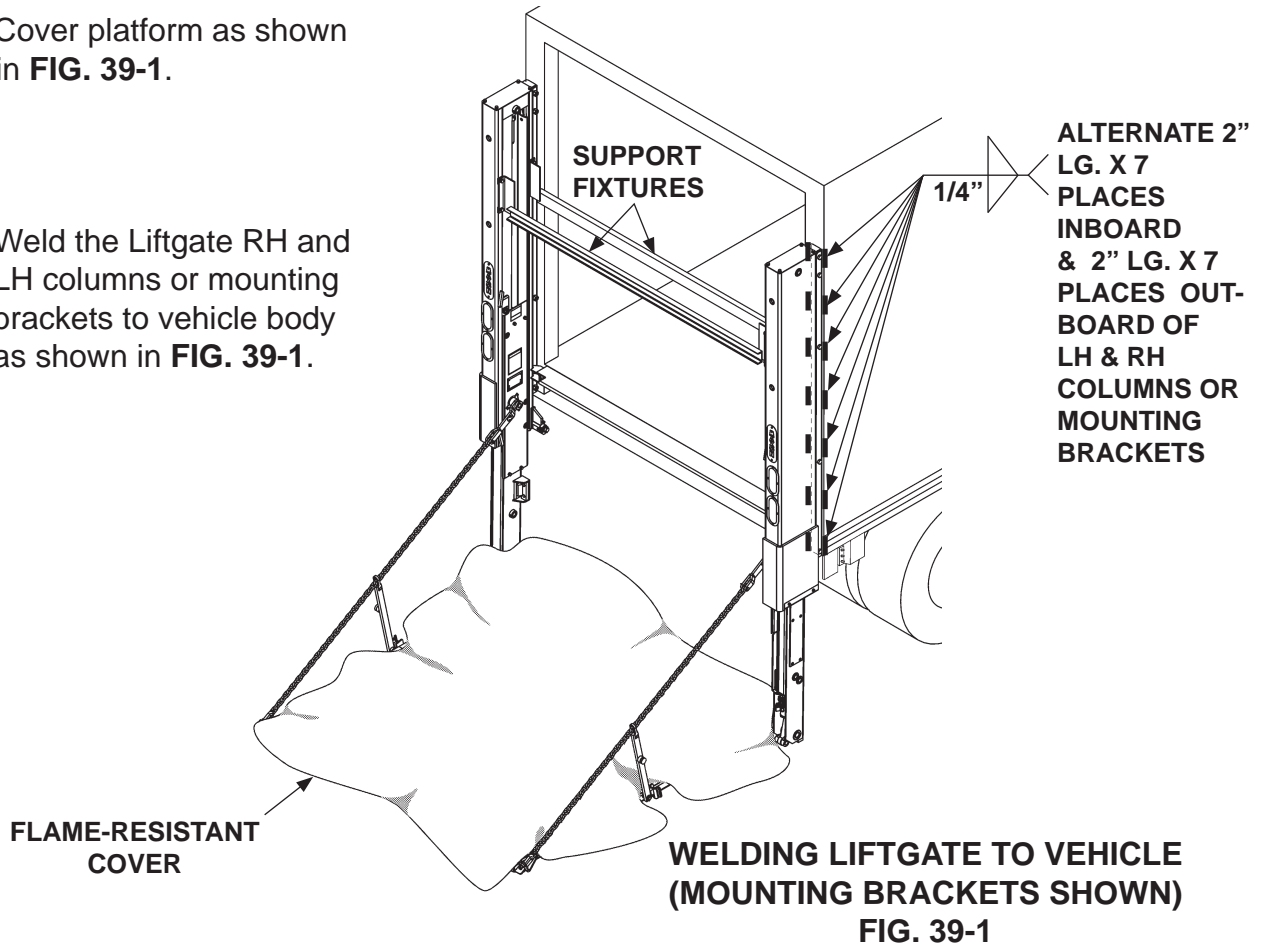

STEP 15 - FINISH WELDING LIFTGATE TO VEHICLE - Continued

CAUTION

To prevent damage to Liftgate components, welder ground must be connected to vehicle body.

4. Make sure platform is at ground level to provide access to the extension plate.

CAUTION

To protect the original paint system, a 3" wide area of paint must be removed from all sides of the weld area before welding.

NOTE: After welding top of extension plate, if you see a gap between bottom of extension plate & vehicle body sill, fill the gap. Fill the gap with A-36 general purpose steel and the same welds shown in FIG. 40-2.

5. Weld the top and bottom surfaces of extension plate to vehicle body (FIGS. 40-1 and 40-2).

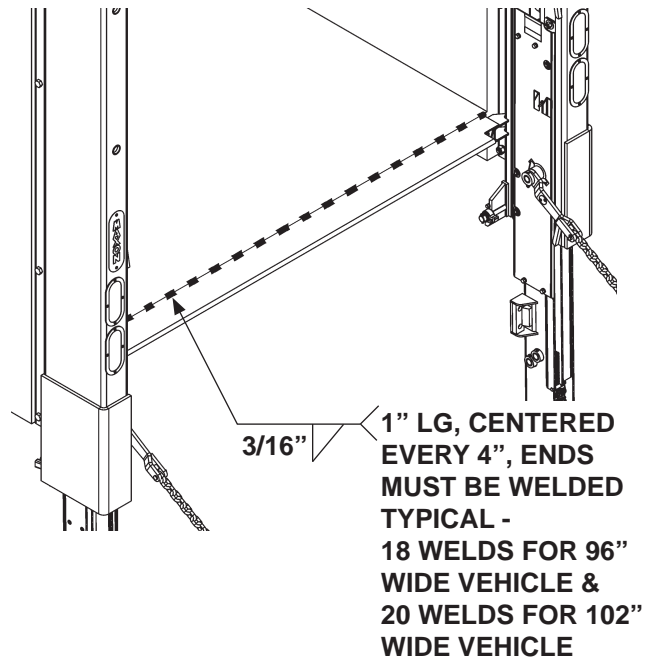

**WELDING TOP OF EXTENSION PLATE
FIG. 40-1**

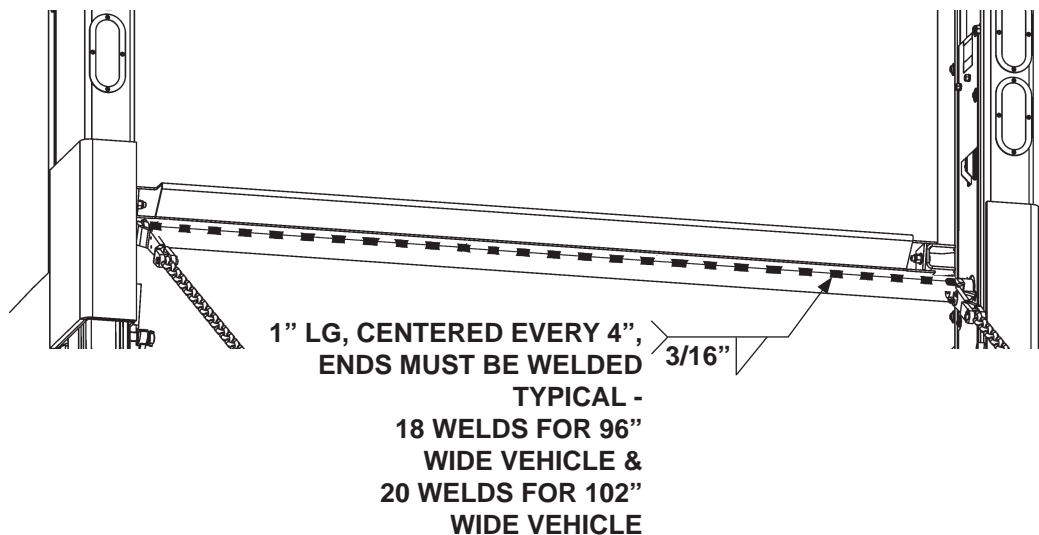

**WELDING BOTTOM OF EXTENSION PLATE
FIG. 40-2**

STEP 15 - FINISH WELDING LIFTGATE TO VEHICLE - Continued

6. Remove nut from positive (+) battery terminal connector. Connect power cable to the positive (+) battery terminal connector (**FIG. 41-1**). Reinstall and tighten nut.

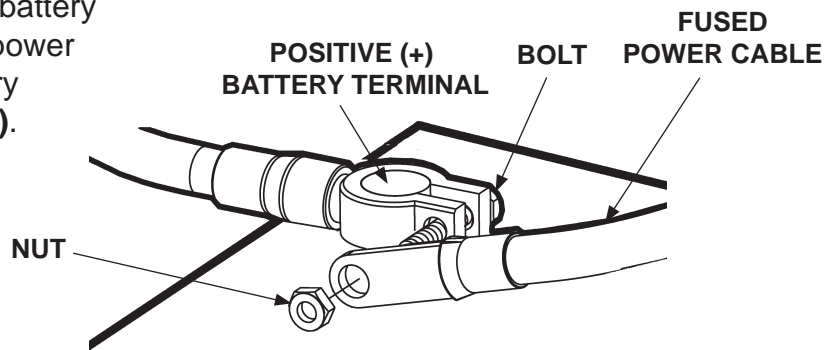

**CONNECTING FUSED POWER CABLE
FIG. 41-1**

STEP 16 - PLATFORM CHAIN ADJUSTMENT

1. Lower the platform to ground level.
Check if tip of the flipover and bottom of the runners touch the ground at the same time (**FIG. 42-1**).

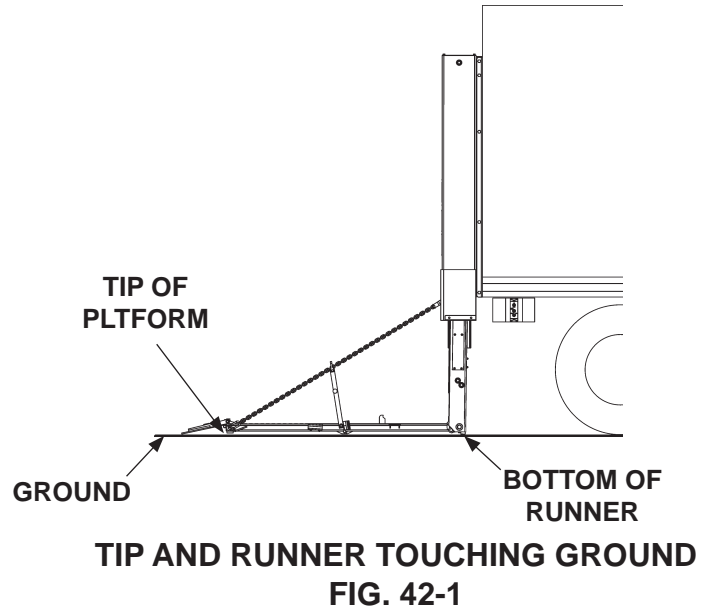

2. If the bottom of the runners are off the ground, measure the distance "H1" (**FIG. 42-2**) from the ground to the bottom of the runners.

- Adjustment is not required if distance "H1" is 1" or less.
- If distance "H1" is more than 1", refer to the steps that follow to adjust the platform chains.

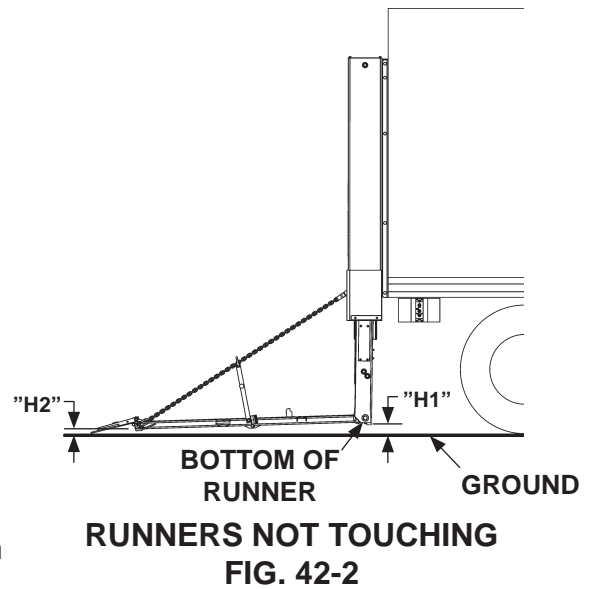

3. Refer to measured distance "H1" at the runners and **TABLE 42-1**. Note the method(s) that will be required to raise the tip of platform (or retention ramp) the expected distance.

MEASURED "H1" (AT RUNNER)	ADJUSTMENT METHODS (● REQUIRED FOR EXPECTED RISE AT TIP)			EXPECTED RISE "H2" (AT TIP)
	ADJUST U-BOLT (RAISES TIP 0" TO 1-1/4")	REMOVE 1 LINK OF BOTH CHAINS (RAISES TIP 1-1/2")	REMOVE 2 LINKS OF BOTH CHAIN (RAISES TIP 3")	
1" - 2-1/4"	●	-	-	0" - 1-1/4"
2-1/2" - 3-3/4"	●	●		1-1/2" - 2-3/4"
4"	●	●	●	3" - 4"

TABLE 42-1

STEP 16 - PLATFORM CHAIN ADJUSTMENT - Continued

⚠ WARNING

Personal injury and damaged equipment could result if chains separate from platform under load. Ensure each leg of u-bolts extends minimum of 1/8" from lock nut. When adjustment is complete, ensure jam nuts are tightened securely.

- To adjust with the u-bolt, do the following. If necessary, raise platform enough to gain access to the adjusting nuts on both u-bolts. Next, loosen the jam nuts on both u-bolts (FIG. 43-1B). Alternately and equally tighten the lock nuts on each u-bolt (FIGS. 43-1B and 43-1C). Then, measure distance "H2" at the tip of the platform (FIG. 43-1A). When distance "H2" is equal to distance "H1" (+0" / -1"), or u-bolt is at maximum adjustment (FIG. 43-1C), securely tighten jam nuts on both u-bolts.

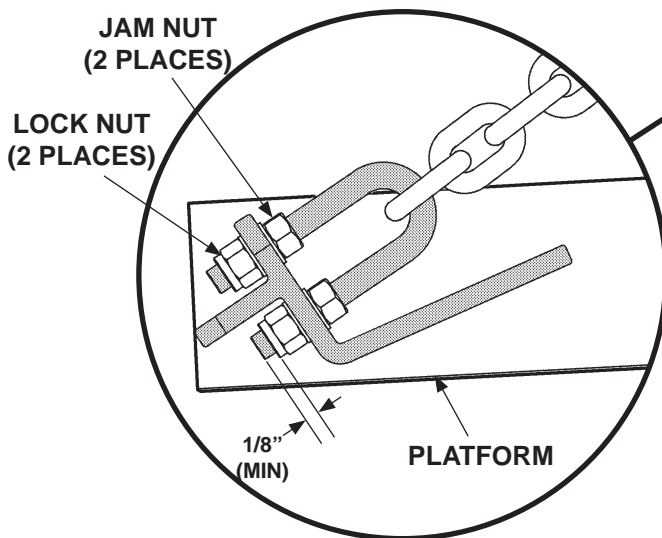

**U-BOLT AT MINIMUM LIMIT
(RH SIDE SHOWN)
FIG. 43-1B**

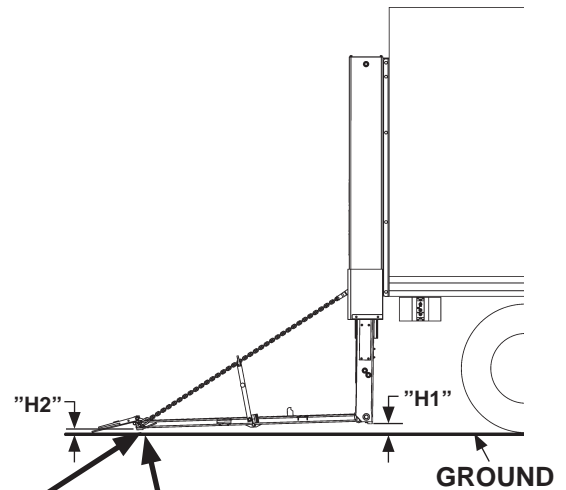
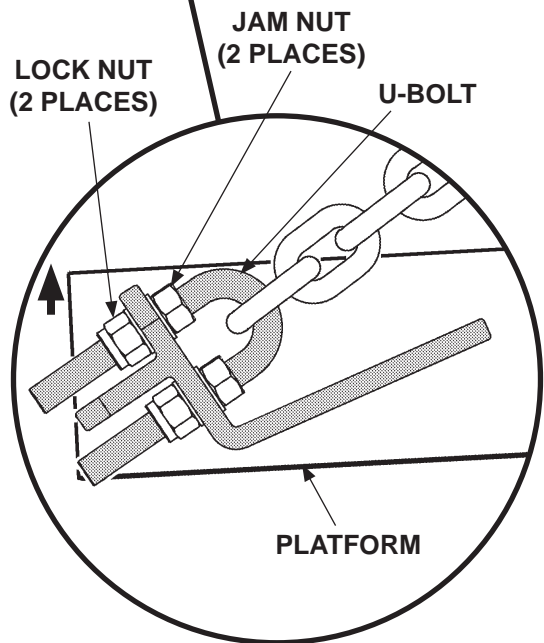

FIG. 43-1A



**U-BOLT ADJUSTED TO MAXIMUM
LIMIT (RH SIDE SHOWN)
FIG. 43-1C**

STEP 16 - PLATFORM CHAIN ADJUSTMENT - Continued

NOTE: Remove links from platform chains only if required. Skip instruction 5 if u-bolts raised tip of the platform (or retention ramp) to correct height.

- To remove links from each platform chain, do the following. Raise platform to a comfortable work height (**FIG. 44-1A**). Support the bottom of platform to remove tension from LH and RH chains. Next, unfasten both u-bolts from platform (**FIG. 44-1B**). Remove 1 or 2 links (as required) from both chains. Then, fasten u-bolts to platform as shown in **FIG. 44-1C**. Tighten jam nuts securely.

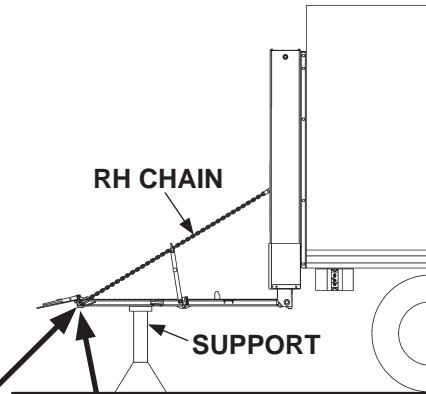

**PLATFORM RAISED & SUPPORTED
FIG. 44-1A**

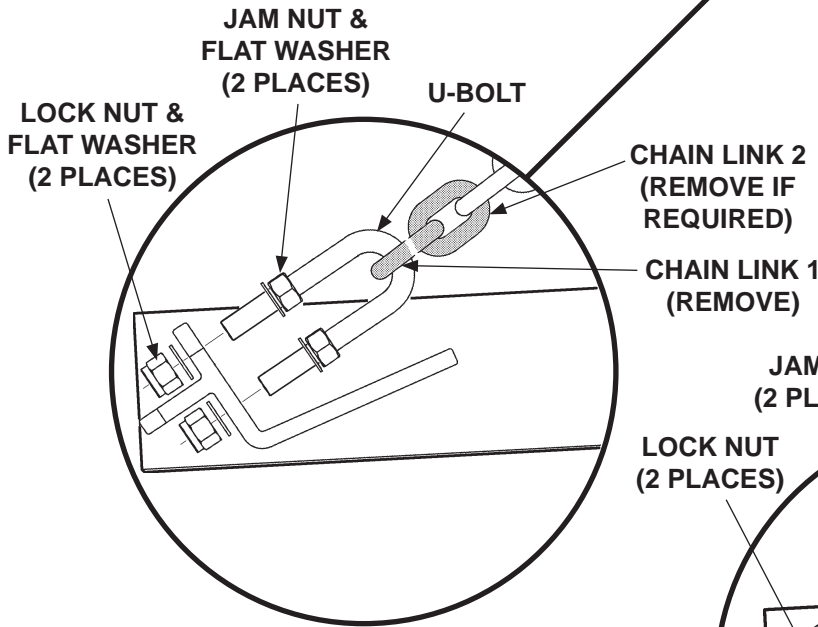

**REMOVING CHAIN LINK
FIG. 44-1B**

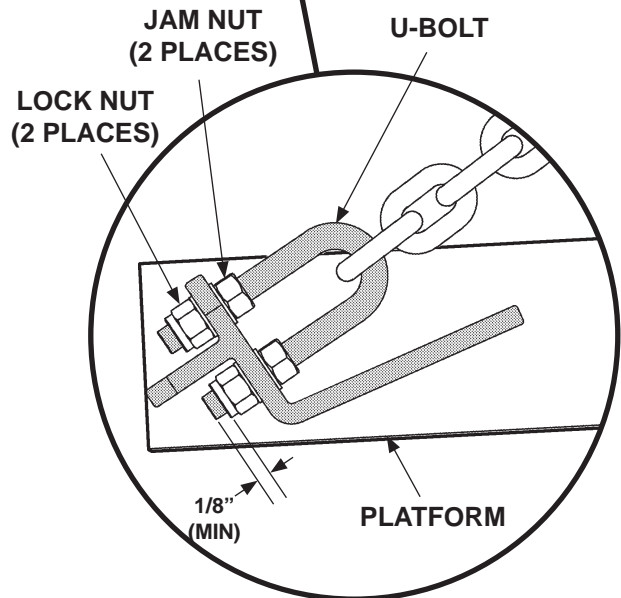

**U-BOLTS FASTENED TO PLATFORM
(RH SIDE OF PLATFORM SHOWN)
FIG. 44-1C**

STEP 16 - PLATFORM CHAIN ADJUSTMENT - Continued

6. Raise platform enough to remove supports. Then, lower platform to the ground (**FIG. 45-1**). Tip of flipover and runners should touch the ground at the same time as shown in **FIG. 45-1**. If necessary, repeat instructions 3 through 5 until tip of platform and runners touch ground at the same time.

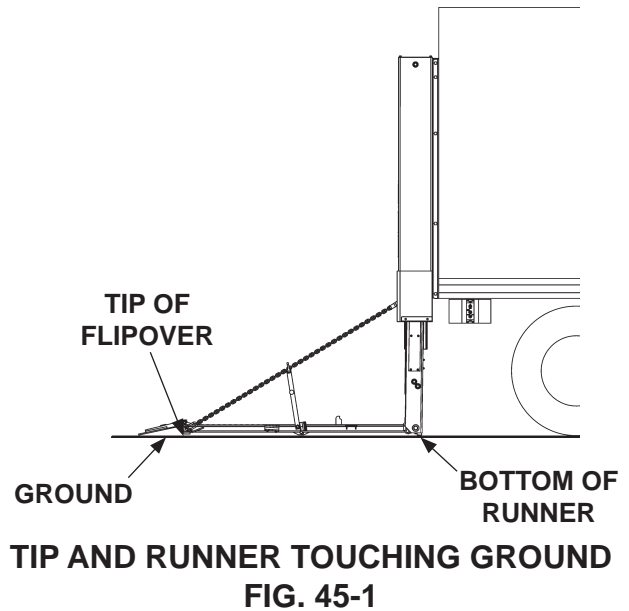

STEP 17 - REMOVE UPPER SUPPORT FIXTURES

⚠ CAUTION

Upper support fixtures are heavy. To prevent injury to installer and damage to Liftgate, use forklift or hoist to hold support fixtures during removal.

1. Stow the platform as shown in **FIG. 46-1A**.
2. Position forklift or hoist to hold upper support fixtures as shown in **FIG. 46-1A**.
3. Unbolt the 2 upper support fixtures from the LH column (**FIGS. 46-1A and 46-1B**). Repeat for RH column. Remove upper support fixtures from work area.

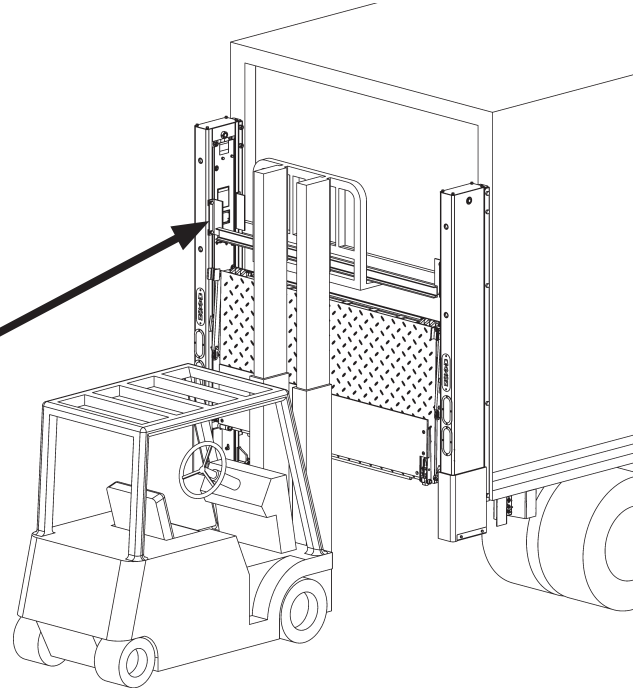

FIG. 46-1A

**UPPER SUPPORT
FIXTURES**

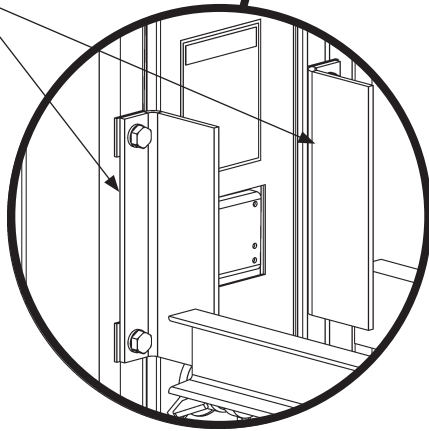
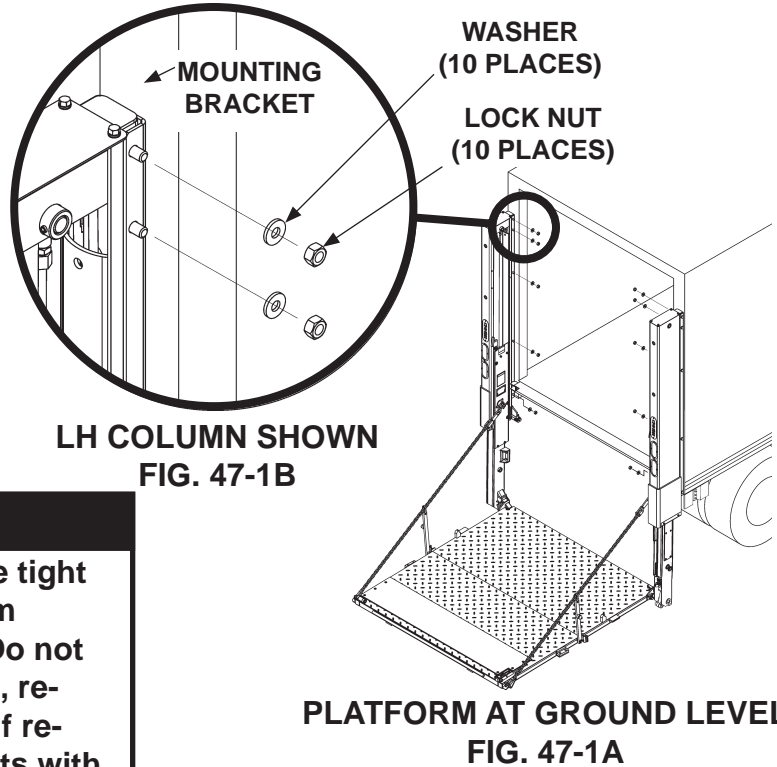

FIG. 46-1B

STEP 18 - REPLACE NUTS ON MOUNTING BRACKETS

NOTE: If the flanged lock nuts were removed from the Liftgate mounting brackets for any reason, they must be replaced with the new flanged lock nuts supplied with parts box.

1. Open and lower platform to ground level as shown in FIG. 47-1A.



2. Remove washers and lock nuts from LH mounting brackets (FIGS. 47-1A and 47-1B).

CAUTION
Ensure flange lock nuts are tight enough for flange to bottom against column brackets. Do not overtighten. Once installed, re-tightening is not required. If removed, replace the lock nuts with new flange lock nuts from MAXON. Never reuse the old nuts.

3. Install flange lock nuts (parts box) and flat washer (parts box) on LH mounting brackets (FIGS. 47-2A and 47-2B).

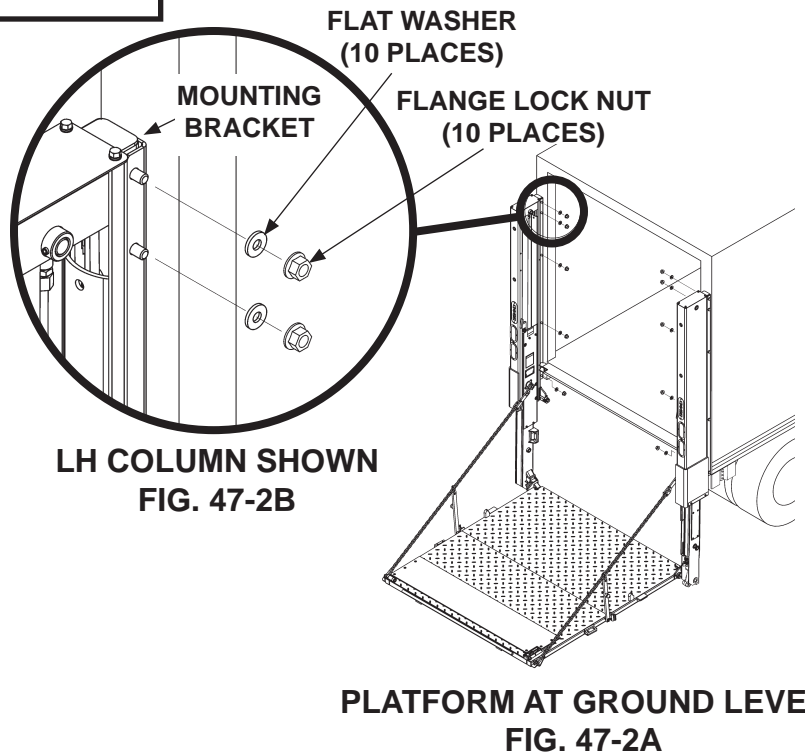

4. Repeat instructions 2 and 3 for the RH mounting brackets.

11921 Slauson Ave. Santa Fe Springs, CA. 90670 (800) 227-4116 FAX (888) 771-7713
MAXON

STEP 19 - PLACE "ALIGN ARROWS" DECAL

NOTE: Make sure **RUNNERS** are raised all the way up (closest to top of **COLUMN**) before doing the following steps.

1. Cut decal **H** (**FIG. 48-1**) on dashed lines to make 2 pieces as shown in **FIG. 48-2**. Peel backing from largest piece of decal and place it on **RUNNER** as shown in **FIG. 48-3**.

2. Peel backing from smallest piece of decal and place it on **COLUMN** as shown in **FIG. 48-3**.

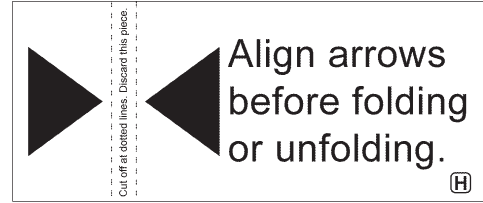

FIG. 48-1

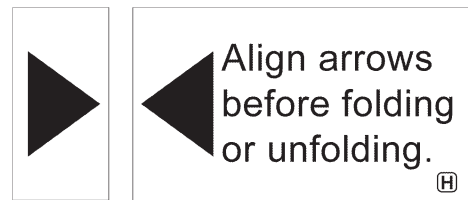

FIG. 48-2

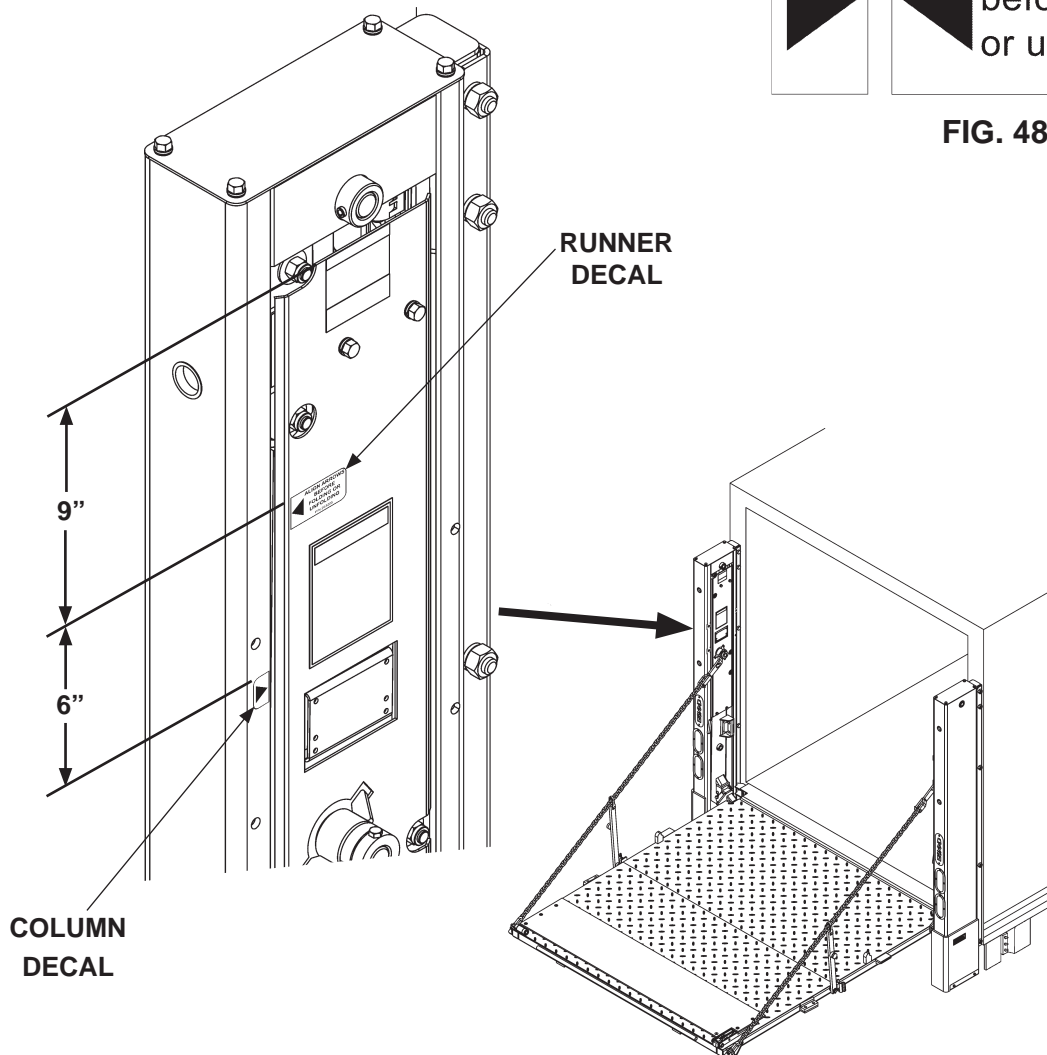

FIG. 48-3

ATTACH DECALS

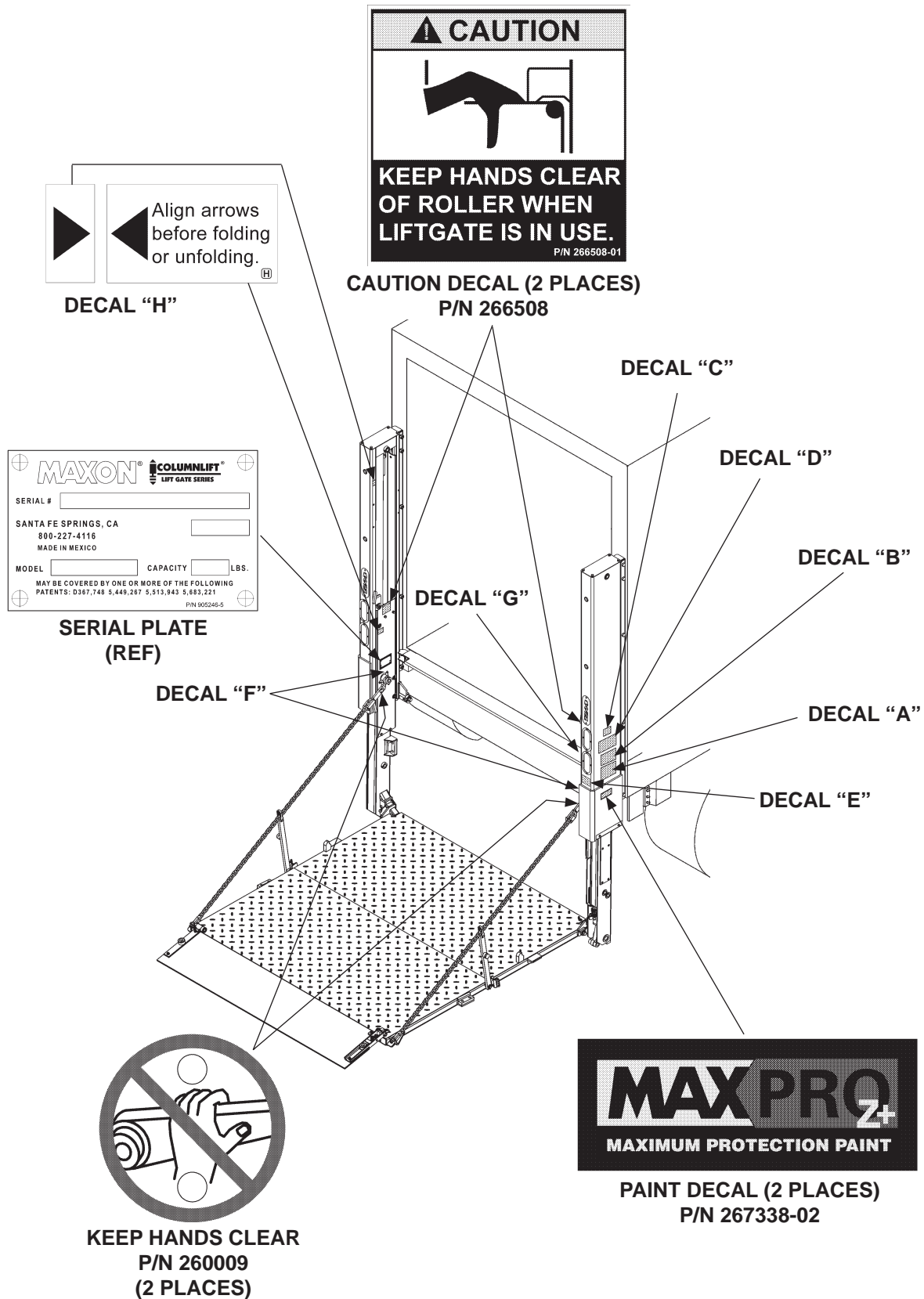

FIG. 49-1

DECALS - Continued

SAFETY INSTRUCTIONS

Read all decals and operation manual before operating liftgate.

1. Do not use liftgate unless you have been properly instructed and have read, and are familiar with, the operating instructions.
2. Be certain vehicle is properly and securely braked before using the liftgate.
3. Always inspect this liftgate for maintenance or damage before using it. Do not use liftgate if it shows any sign of damage or improper maintenance.
4. Do not overload
5. Make certain the area in which the platform will open and close is clear before opening or closing the platform.
6. Make certain platform area, including the area in which loads may fall from platform, is clear before and at all times during operation of liftgate.
7. This liftgate is intended for loading and unloading of cargo only. Do not use this liftgate for anything but its intended use.

(A)

WARNING

Read this information carefully.

- Improper operation of this Liftgate can result in serious personal injury. If you do not have a copy of the operating instructions, please obtain them from your employer, distributor, or lessor before you attempt to operate Liftgate.
- If there are signs of improper maintenance, damage to vital parts, or slippery platform surface, do not use the Liftgate until these problems have been corrected.
- If you are using a pallet jack, be sure it can be maneuvered safely.
- Do not operate a forklift on the platform.
- Do not allow any part of yours or your helper's body to be placed under, within, or around any portion of the moving Liftgate, or its mechanisms, or in a position that would trap them between the platform and the ground or truck when the Liftgate is operated.
- If a helper is riding the platform with you, make sure you are both doing so safely and that you are not in danger of coming in contact with any moving or potentially moving obstacles.
- **USE GOOD COMMON SENSE.**
- If load appears to be unsafe, do not lift or lower it.

For a free copy of other manuals that pertain to this model Liftgate, please visit our website at www.maxonlift.com or call Customer Service at (800) 227-4116.

(B)

THE MAXIMUM CAPACITY
OF THIS LIFT IS

_____ **POUNDS**

WHEN THE LOAD IS
CENTERED ON THE LOAD
CARRYING PLATFORM

(C)

WARNING

Liftgate hazards can result in crushing or falling.

Keep hands and feet clear of pinch points.

If riding liftgate, make sure load is stable and footing is solid.

Read and understand all instructions and WARNINGS before use.

(D)

CAUTION

Always stand clear of platform area.

(E)

CAUTION

Do not grease columns.

(F)

UP ↑

DOWN ↓

(G)

Align arrows before folding or unfolding.

(H)

DECAL SHEET
FIG. 50-1

MODEL	ORDER P/N	DECAL "C"
BMRSD35	268309-01	3500 LBS.
BMRSD44	268309-02	4400 LBS.
BMRSD55	268309-03	5500 LBS.
BMRSD66	268309-04	6600 LBS.

DECAL SHEET PART NUMBERS
TABLE 50-1

11921 Slauson Ave. Santa Fe Springs, CA. 90670 (800) 227-4116 FAX (888) 771-7713

MAXON

TOUCHUP PAINT

CAUTION

Damaged cylinder seals and contaminated hydraulic fluid can result from painting the polished portion of the cylinder rod. To prevent damage, protect the exposed polished portion of the cylinder rod while painting.

If bare metal or primer is exposed on the painted portions of the Liftgate, touch up the paint. To maintain the protection provided by the original paint system, **MAXON** recommends zinc primer touchup paint kit, P/N 908135-01.

MAXON[®] 11921 Slauson Ave. Santa Fe Springs, CA. 90670 (800) 227-4116 FAX (888) 771-7713

OPTIONS

RECOMMENDED LIFTGATE POWER CONFIGURATION

NOTE: Make sure the Liftgate power unit, and all batteries on the vehicle for the power unit, are connected correctly to a common chassis ground.

1. Liftgate, pump box, and additional battery box are typically installed on trailers as shown in **FIG. 52-1** and on trucks as shown in **FIG. 52-2**. See the following page for battery and cable connections.

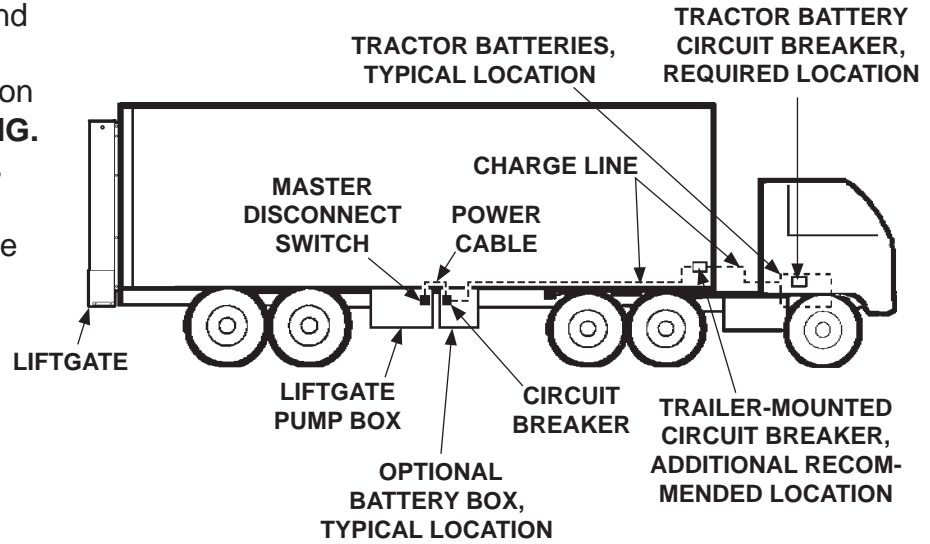

**RECOMMENDED LIFTGATE & BATTERY BOX
INSTALLATION ON TRAILER
FIG. 52-1**

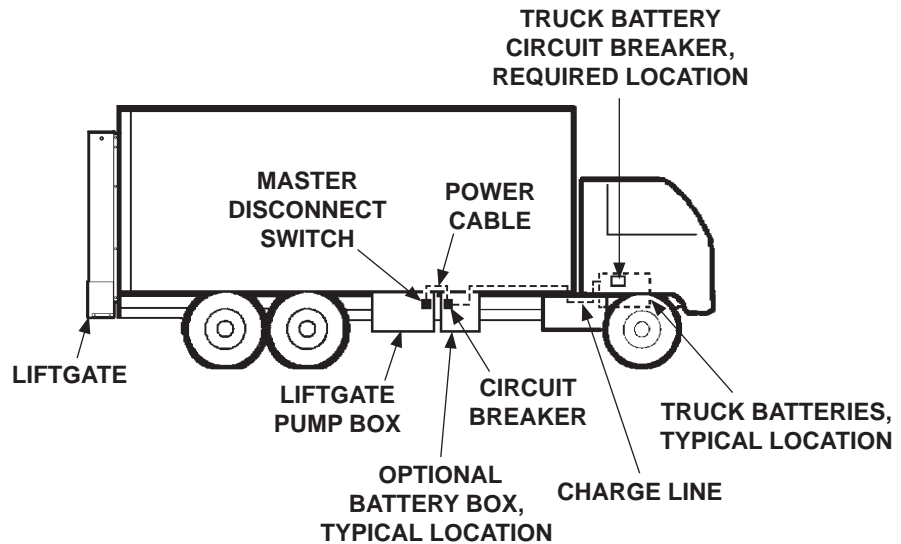

**RECOMMENDED LIFTGATE & BATTERY BOX
INSTALLATION ON TRUCK
FIG. 52-2**

OPTIONS

RECOMMENDED LIFTGATE POWER CONFIGURATION - Continued

NOTE: Always connect fused end of power cable to battery positive (+) terminal.

2. Recommended battery box setup for **6 volt batteries** is shown in **FIG. 53-1**.

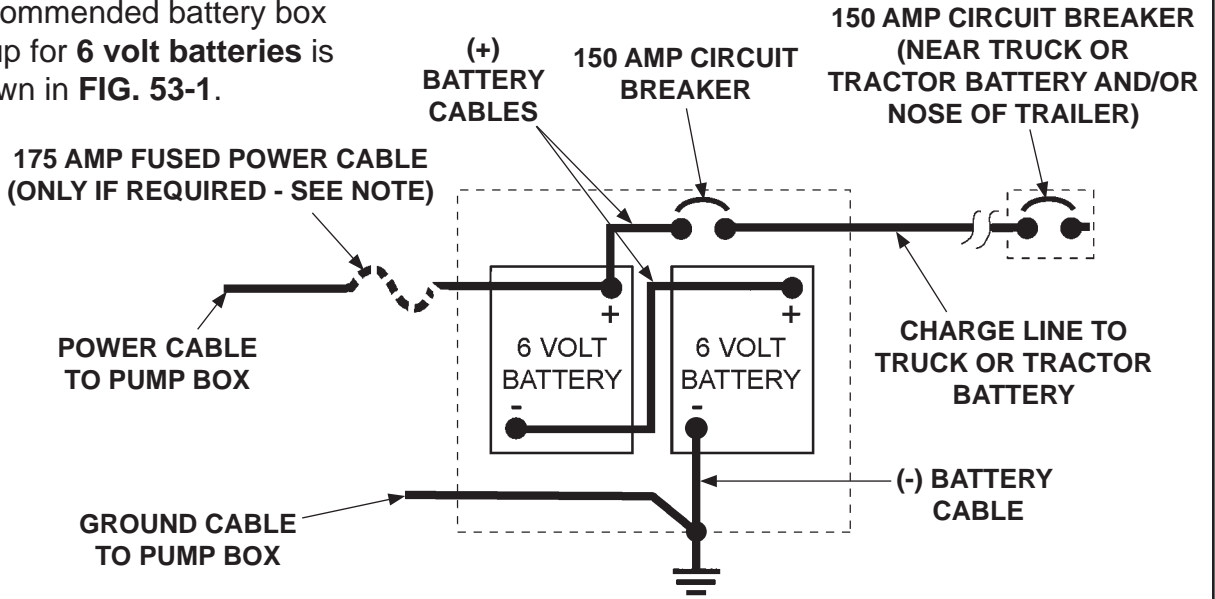

6 VOLT BATTERY CONNECTIONS
FIG. 53-1

NOTE: Always connect fused end of power cable to battery positive (+) terminal.

3. Recommended battery box setup for **12 volt batteries** is shown in **FIG. 53-2**.

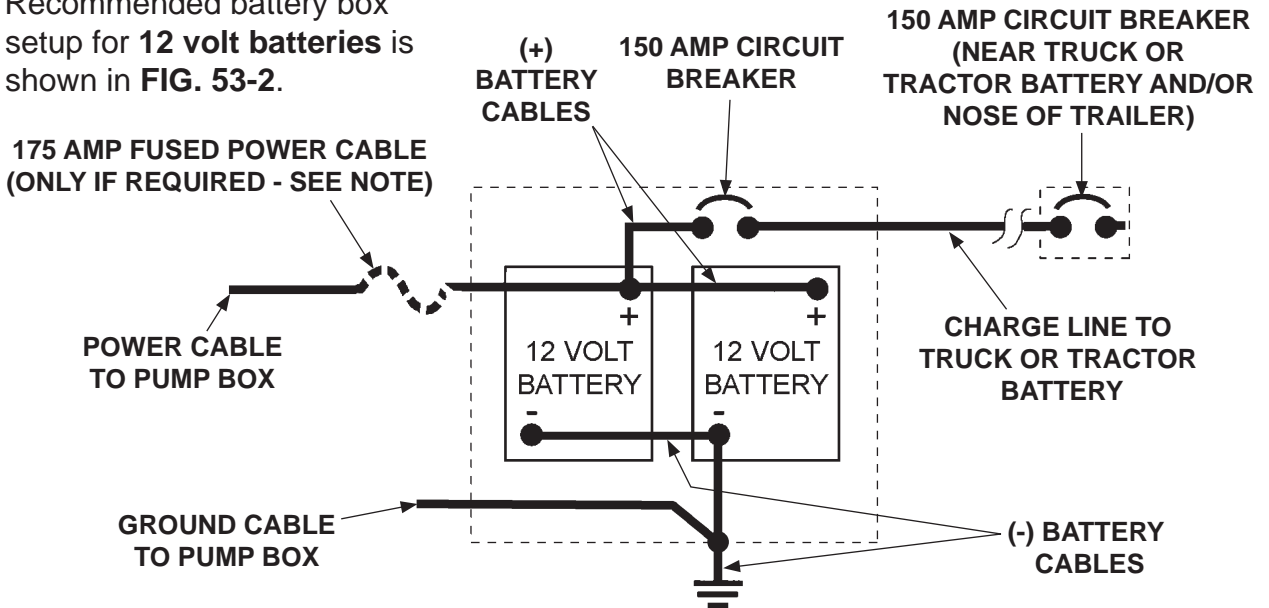

12 VOLT BATTERY CONNECTIONS
FIG. 53-2

HYDRAULIC SYSTEM DIAGRAMS

PUMP & MOTOR SOLENOID OPERATION - POWER DOWN

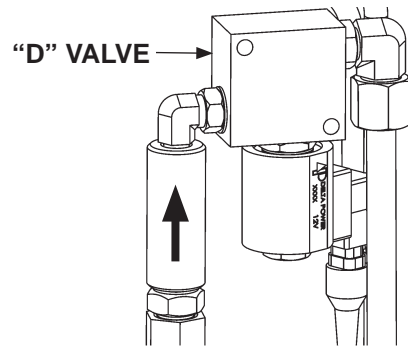
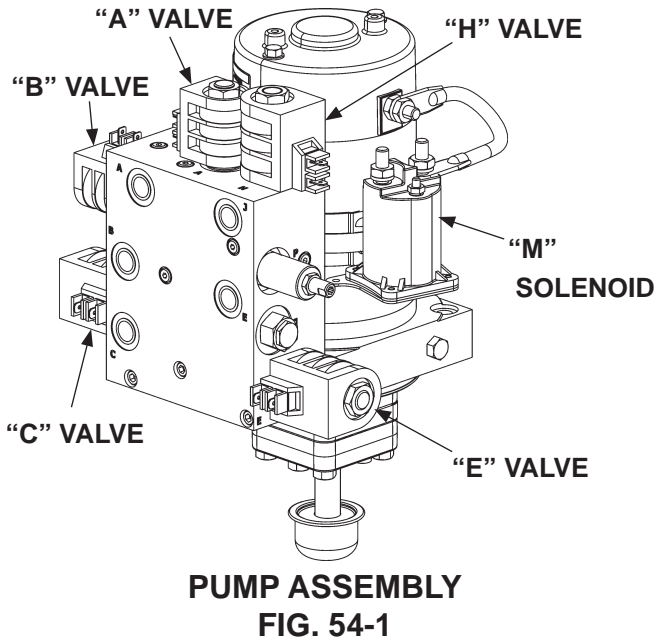

POWER UNIT MOTOR & SOLENOID OPERATION - POWER DOWN										
LIFTGATE FUNCTION	PORT	SOLENOID OPERATION (✓ MEANS ENERGIZED)								
		SWITCH	RELAY	MOTOR	VALVE "A"	VALVE "B"	VALVE "C"	VALVE "D"	VALVE "E"	VALVE "H"
LIFT	B	"PD"	-	✓	-	-	-	-	-	-
LOWER	C		-	✓	-	✓	✓	✓	-	-
OPEN	J		-	✓	✓	-	-	-	✓	✓
CLOSE	A		-	✓	-	-	-	-	✓	-
REFER TO VALVES SHOWN ON HYDRAULIC SCHEMATIC										

TABLE 54-1

HYDRAULIC SYSTEM DIAGRAMS

PUMP & MOTOR SOLENOID OPERATION - GRAVITY DOWN

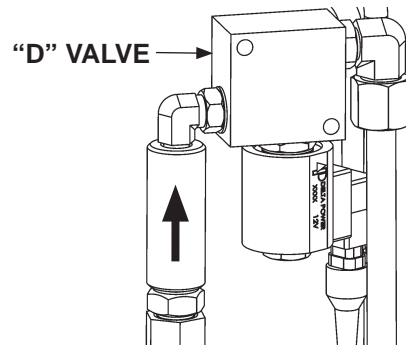
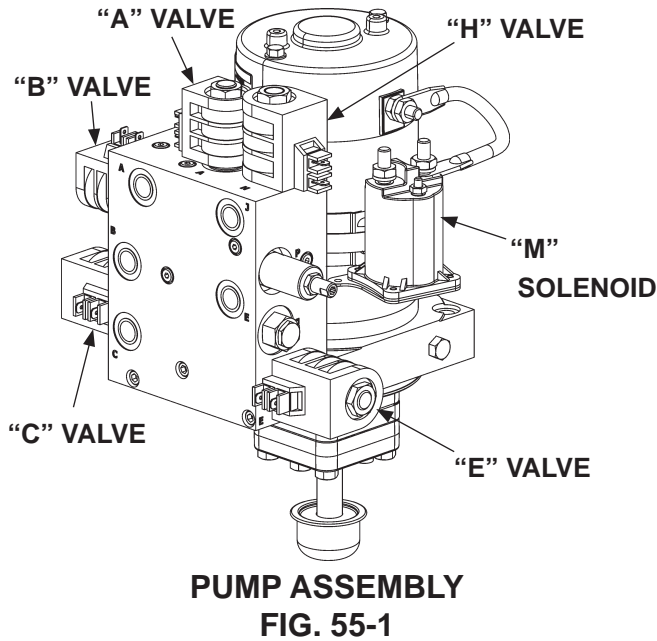

POWER UNIT MOTOR & SOLENOID OPERATION - GRAVITY DOWN										
LIFTGATE FUNCTION	PORT	SOLENOID OPERATION (✓ MEANS ENERGIZED)								
		SWITCH	RELAY	MOTOR	VALVE "A"	VALVE "B"	VALVE "C"	VALVE "D"	VALVE "E"	VALVE "H"
LIFT	B	"GD"	-	✓	-	-	-	-	-	-
LOWER	C		✓	-	-	✓	-	✓	-	-
OPEN	J		-	✓	✓	-	-	-	✓	✓
CLOSE	A		-	✓	-	-	-	-	✓	-
REFER TO VALVES SHOWN ON HYDRAULIC SCHEMATIC										

TABLE 55-1

HYDRAULIC SYSTEM DIAGRAMS

SINGLE PUMP BOX HYDRAULIC SCHEMATIC

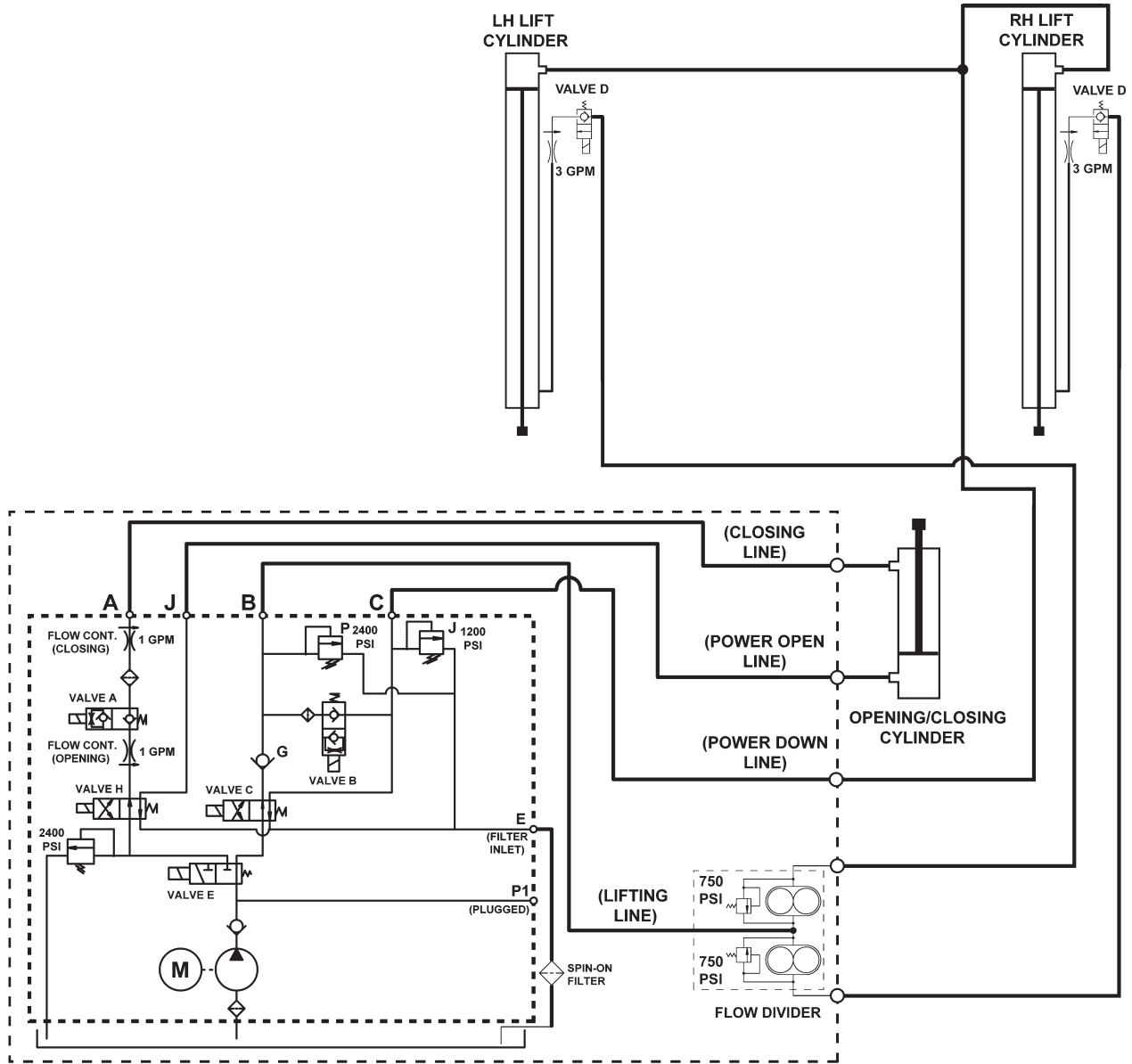

FIG. 56-1

HYDRAULIC SYSTEM DIAGRAMS

DUAL PUMP BOX HYDRAULIC SCHEMATIC

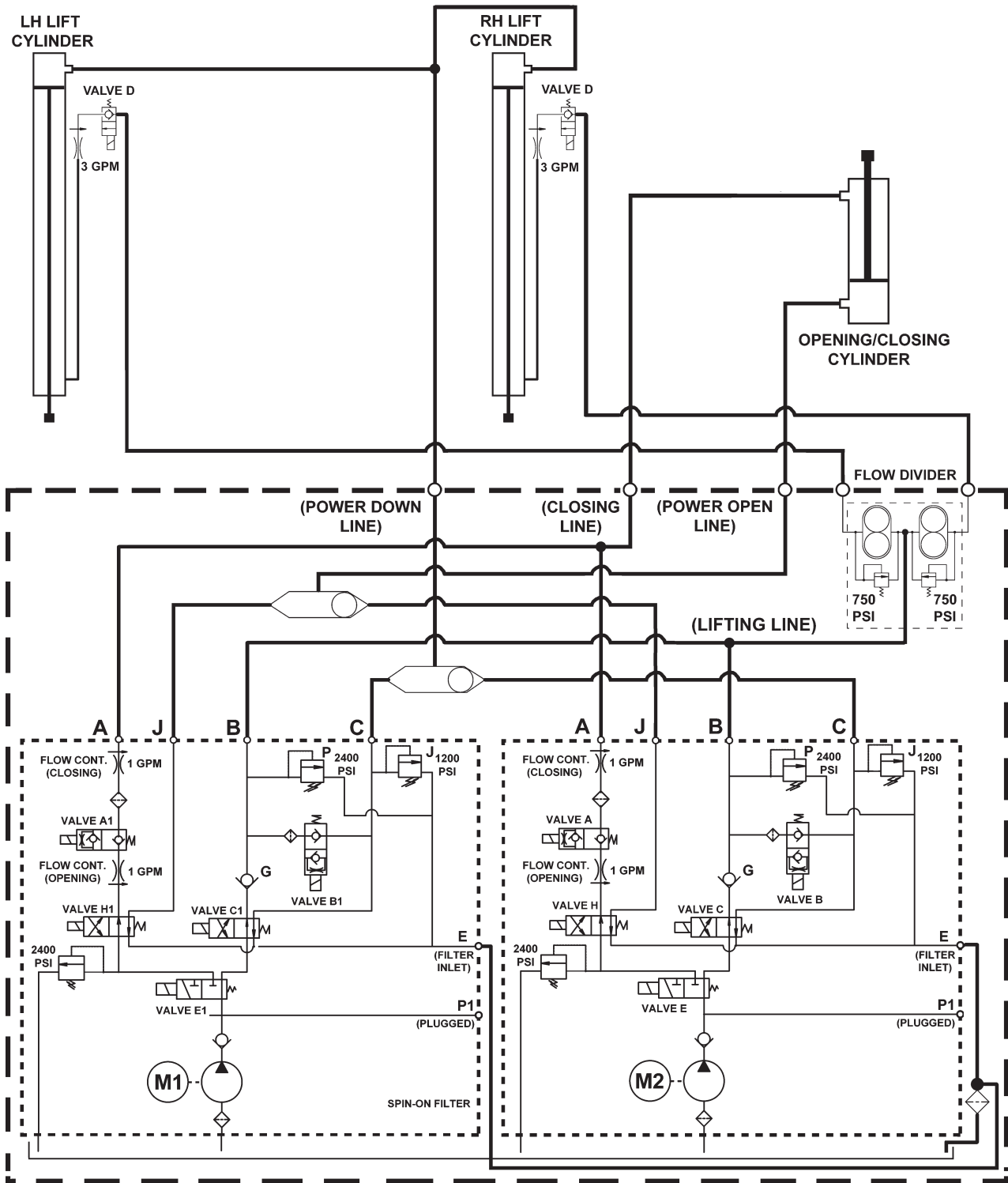

FIG. 57-1

ELECTRICAL SYSTEM DIAGRAMS

INTERCONNECTING ELECTRICAL SCHEMATIC

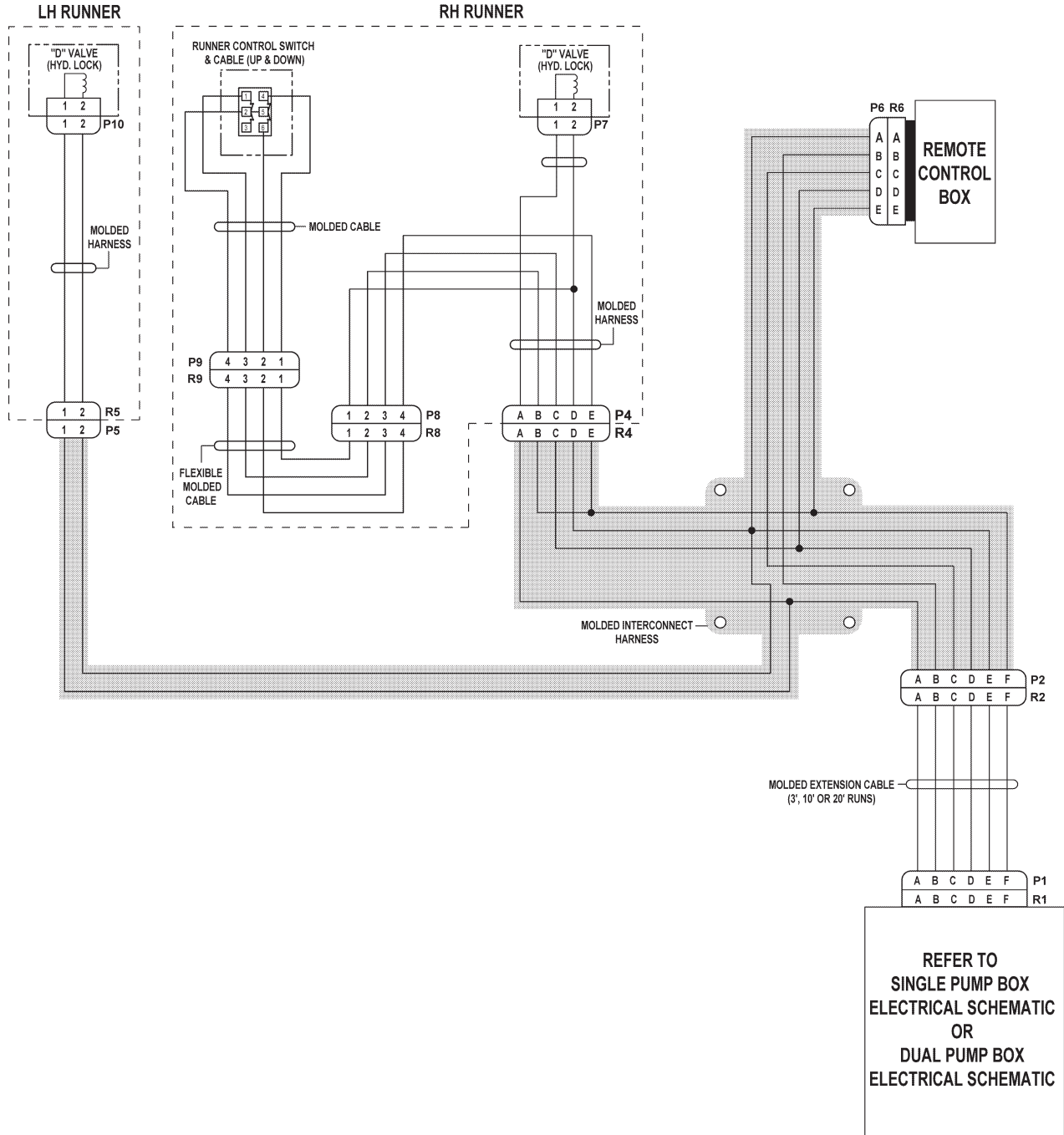

FIG. 58-1

ELECTRICAL SYSTEM DIAGRAMS

SINGLE PUMP BOX ELECTRICAL SCHEMATIC

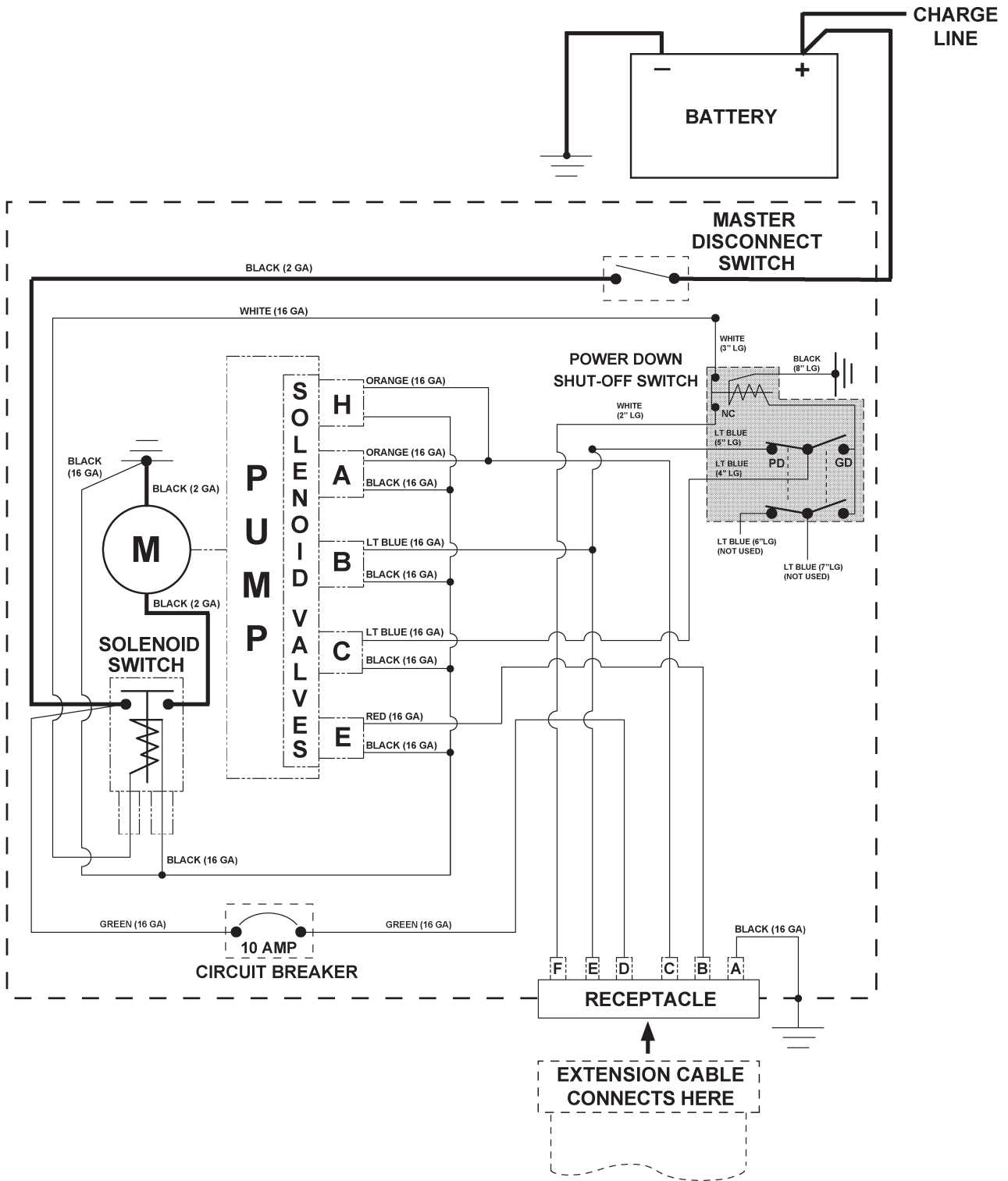

FIG. 59-1

11921 Slauson Ave. Santa Fe Springs, CA. 90670 (800) 227-4116 FAX (888) 771-7713
MAXON

ELECTRICAL SYSTEM DIAGRAMS

DUAL PUMP BOX ELECTRICAL SCHEMATIC

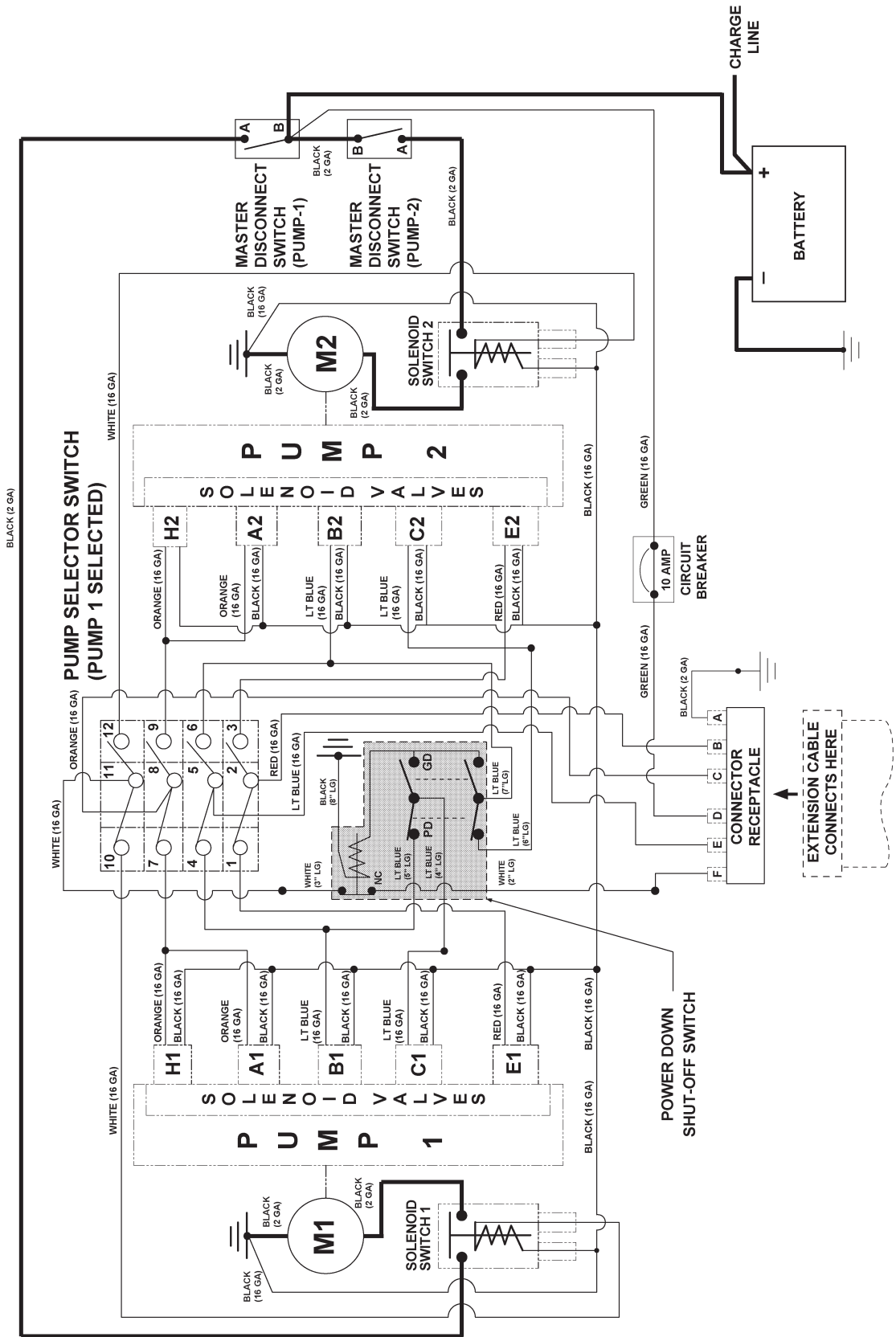

FIG. 60-1

MAXON[®]

PRE-DELIVERY INSPECTION FORM BMRSD MODELS

Model: _____

Date: _____

Serial Number: _____

Technician: _____

Pre-Installation Inspection:

- Correct Model
- Correct Capacity
- Correct Platform Size
- Correct Options
- Manuals & Decals

Structural Inspection:

- Inspect alignment of Final Assembly
- Inspect Pump Box secure mounting
- Inspect all installation welds
- Check Roll Pins, Bolts and Fasteners
- Check for no twists in Chain
- Check for Torsion Spring engagement
- Ensure Platform Ramp touches ground

Hydraulic Inspection:

- Proper Fluid Level (See Step 14 - Optimize Hydraulic Fluid Level)
- Check fittings for leaks in Pump Box
- Check fittings for leaks in Columns

Electrical Inspection:

- Check Power/Charge Plug and Terminal
- Check for loose wires and Terminals
- Circuit Breaker
- Battery hookup, 6 Volt vs. 12 Volt
- Check for fully charged Batteries
- Inspect all Solenoid connections
- Check all wiring harness connections
- Outside Control Box location
- Check electrical cable connections (at the bottom of the curb-side Runner) tight and secure

Operation Inspection:

NOTE: The following times are for 56" bed height, ISO 32 grade oil, & temperature at 70°F.

- Check operation of outside control
- Check operation of Runner control
- Platform unfolds in 4 to 6 seconds
- Platform folds in 5 to 10 seconds
- Platform lowers in 21 to 25 seconds
- Platform raises in 26 to 30 seconds
- Platform raises and lowers evenly
- Platform stores and locks securely behind both Column Wedges
- Check lift operation under load
- Decals in correct location and legible

11921 Slauson Ave. Santa Fe Springs, CA. 90670 (800) 227-4116 FAX (888) 771-7713

MAXON[®]

