

MAXON®

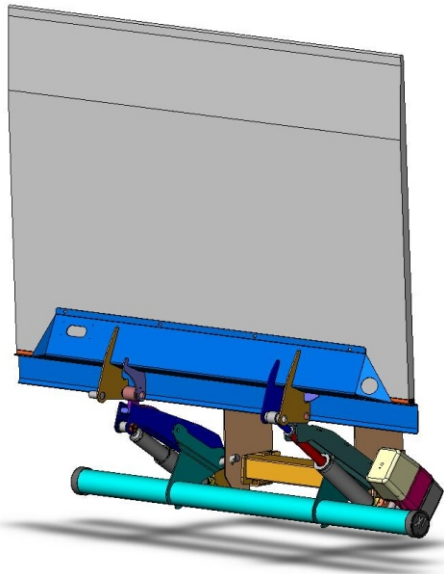

Cantilever GPC X1 Operator`s Manual

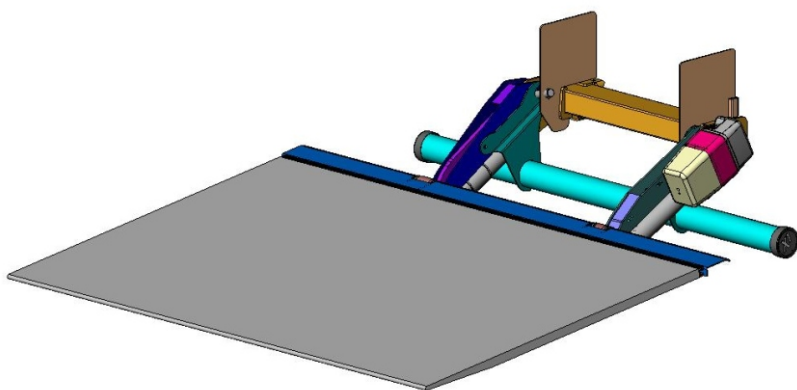

Liftgate
Series

GPC 22 X1

GPC 33 X1

GPC 44 X1

GPC 55 X1

MAXON®
Lift CORP.

11921 Slauson Avenue.
Santa Fe Springs, CA 90670
(800) 227 - 4116

X1
TECHNOLOGY

Document no.: 20 904 703
Version 15.09.2005

© Sörensen Hydraulik GmbH

General

You have chosen a lift gate of the highest quality. The lift gate is a low maintenance unit. It is equipped with maintenance-free, grease-free bearings and does not require greasing throughout its entire lifetime.

The lift gate may only be used for the raising and lowering of loads, which must be loaded in accordance with the load diagram.

The lift may be operated, maintained and serviced only by persons who have received appropriate training and who have been specifically instructed of the dangers associated with its operation.

The accident prevention regulations, must be observed. If they are not, the manufacturer cannot accept any liability for resultant damage or injury.

These operating instructions are valid for following lift gates :

| Model | Capacity kg | Capacity pounds |
|------------------|-------------|-----------------|
| GPC 22 X1 | 1000 kg | 2200 pounds |
| GPC 33 X1 | 1500 kg | 3300 pounds |
| GPC 44 X1 | 2000 kg | 4400 pounds |
| GPC 55 X1 | 2500 kg | 5500 pounds |

Daily verifications :

- Check for correct and normal operation
- Legibility of all operating and information labels
- Check for weld cracks and make sure all bolts and nuts are tight
- Check for leaks on hoses, valves and hydraulic cylinders
- If platform has warning lights please check for function

The driver should report any incorrect operation or obvious damage to his maintenance department. All damages are to be mended immediately. The lift gate owner is responsible for the repairs of detected damages.

The operating instructions are to be carried in the vehicle at all times.

Yearly check

The lift gate must be checked for damages at least once a year by trained personnel. The results of this verification must be written down in the maintenance book.

Battery capacity

| | | | | |
|----------------------|--|----------|--|----------|
| Lift capacity | Up to | 2200 lbs | Up to | 5500 lbs |
| Battery size | 12V : 1 x 12V 88 Ah 24V : 2 x 12V 66 Ah | | 12 V : 1 x 12V 143 Ah 24 V : 2 x 12V 110 Ah | |
| | Group 31 | | | |

For use in short-haul traffic the next step up should always be selected. Heavy-duty alternators are strongly recommended.

The operator is responsible for the battery capacity and the charge status of the battery.

The electric motor

The electric motor of the power unit has a capacity of 0,8 up to 3 KW. This equals at full charge with 24 Volts a current up to 250 Ampere. If the voltages lowers to 12 Volts, the current doubles up to 500 Ampere.

This high current at low voltage results in overheating of the copper wire on the rotor. The protective sealing melts down which results in a short circuit and a motor burnout.

This how you can prevent it

You can avoid damages to the motor or the power relais if you ensure that you have the right voltage at all times. If the motor has trouble with a load that is normally lifted without a problem, stop the lifting operation immediately and charge the batteries.

If, in your opinion, the batteries are empty too fast, have the batteries and the power cables checked by a specialist. It could be possible that the cables, the mass connection or the batteries have to be repaired or changed.

Switching on the lift gate

Switch the lift gate on with the push button located in the cabin. When the red lamp lits, the lift is ready for operation

Description of the controls

Hand control box

All functions must be operated with two hands by switching the toggle switches located at the side of the hand control box

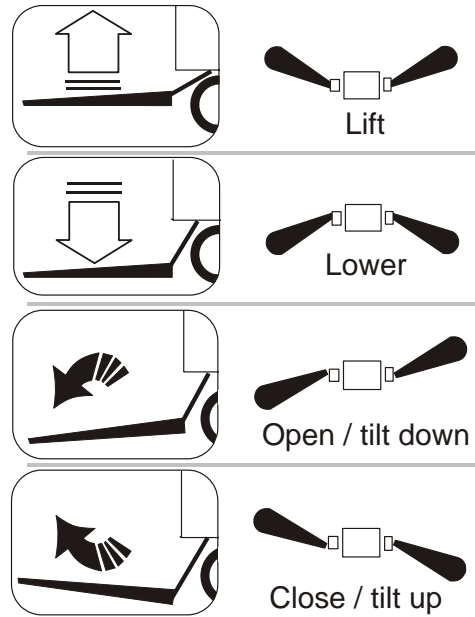
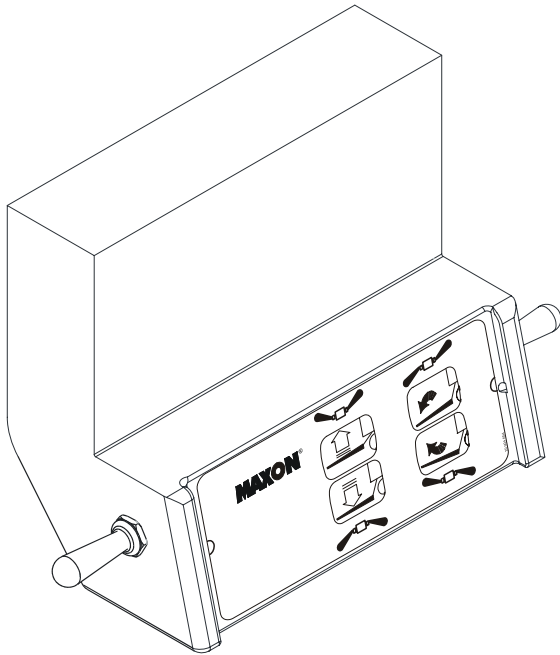

Hand control box 2 Buttons

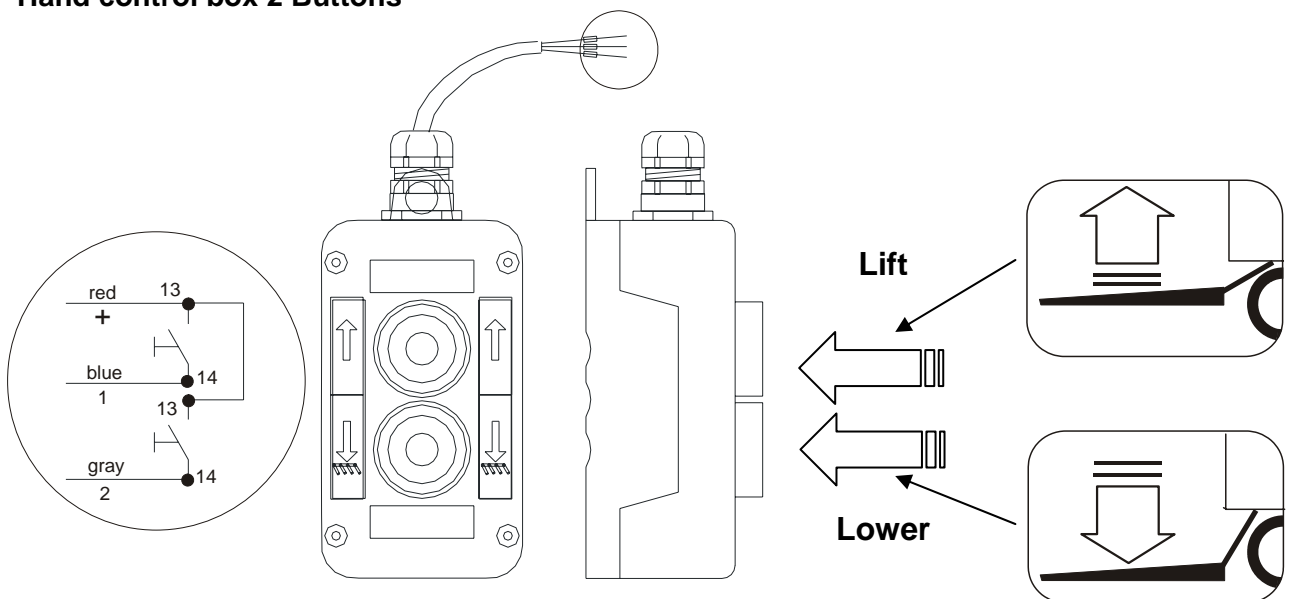

Foot controls (Optional version)

The foot controls are connected so that they only work when switched in turns :

To lift and tilt up

Step 1 - activate foot control button for lowering

Step 2 – activate foot control button for lifting

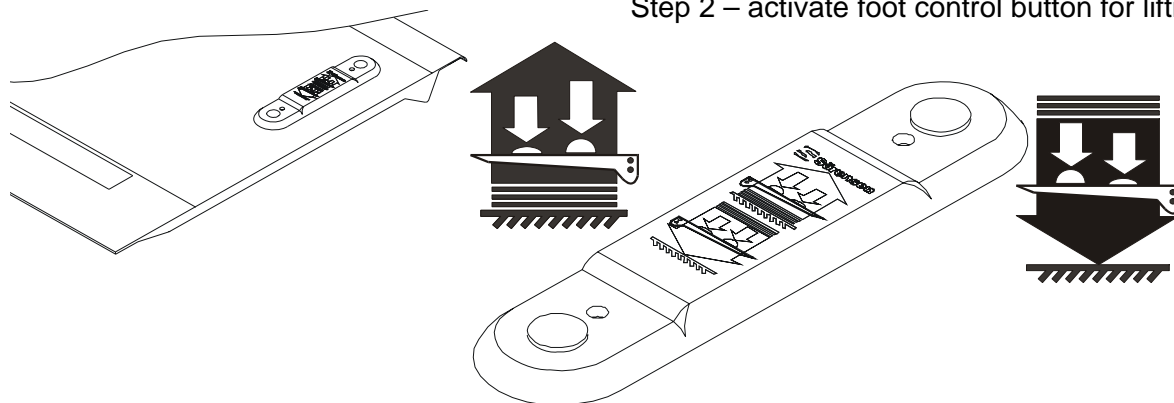

To lower and tilt down

Step 1 -activate foot control button for lifting

Step 2 – activate foot control button for lowering

General Information

Standing on the platform when it is moving

As it is only allowed for the operator to stand on the platform, he must ensure that no other person (especially children) are standing inside the danger zone.

Hazard information for unsecured loads

Under certain circumstances, there is a possibility that the front axle of the vehicle lifts while unloading. On this inclination, unsecure loads may start to slip and create a danger for the operator.

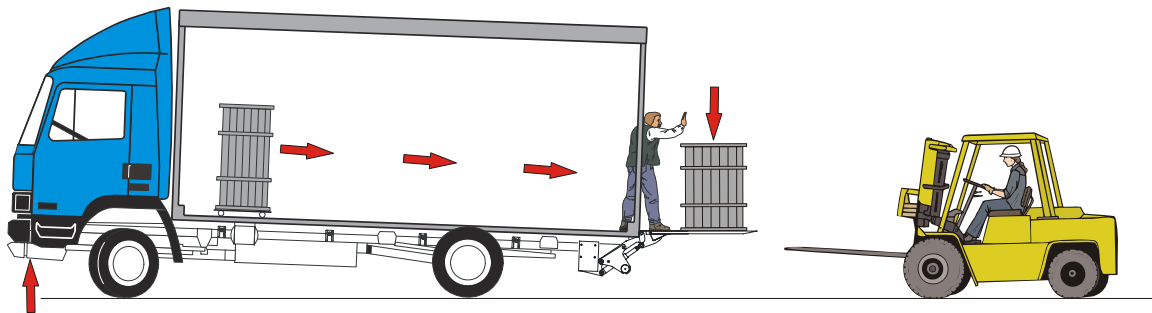

You can purchase a warning sticker

CAUTION ! Secure the load against moving or use mechanical supports

Description of the Safety Installations

Hose Rupture Valves

If a hose, a pipe or a screw connection should burst, the lift gate lowers or inclines in a controlled manner at the permitted speed, as long as a function is connected via one of the control units (hand held remote controls, foot controls or hand control box). If such control unit is not activated, or ceases to be activated, the lift gate stops automatically.

Safety Valve

The lift gate is protected by the factory-set safety valve from raising loads which are heavier than the specified carrying capacity. This valve may only be adjusted by an expert using a test weight and a manometer.

Fuses

Defective fuses may only be replaced by fuses which correspond to the values specified in the wiring diagram and on the distributor plate. Larger fuses may not be blown in the event of malfunctions, which could lead to cables catching fire.

Roll-off Safety Devices

If roller containers are being used, the lift gate should be equipped with roll-off safety devices. Their operation is impaired by dirt; the operator should keep the roll-off safety devices clean at all times.

Warning Flags

The flags can be seen until the platform is on the ground. Both safety installations should be kept clean and in perfect condition at all times.

(Optional version)

Warning Lights

The lights flash as soon as the platform has opened a few degrees.

Standing on the platform when it is moving

When loading the platform, please ensure that you leave enough space for the operator to securely operate the lift gate.

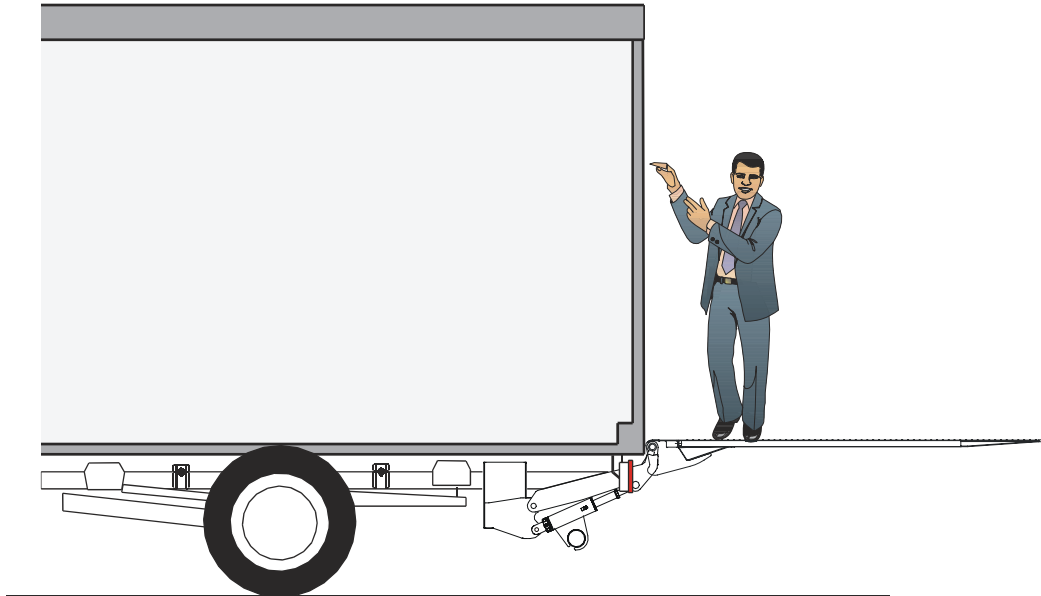

Securing of Loads

Rolling and sliding loads must be secured on the platform. Lift gates come optionally equipped with cart stops, securing rolling loads with the maximum efficiency (wheels with maximum diameter 4")

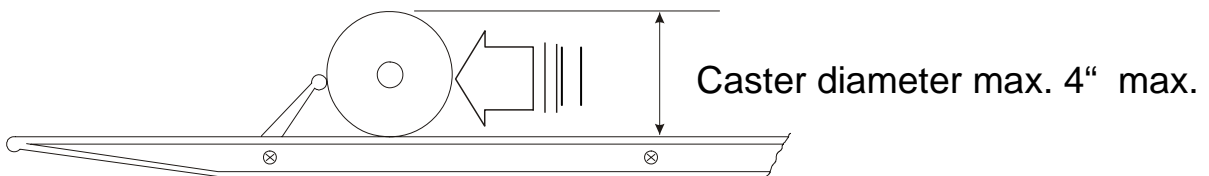

Safety guide for the operation of the lift gate

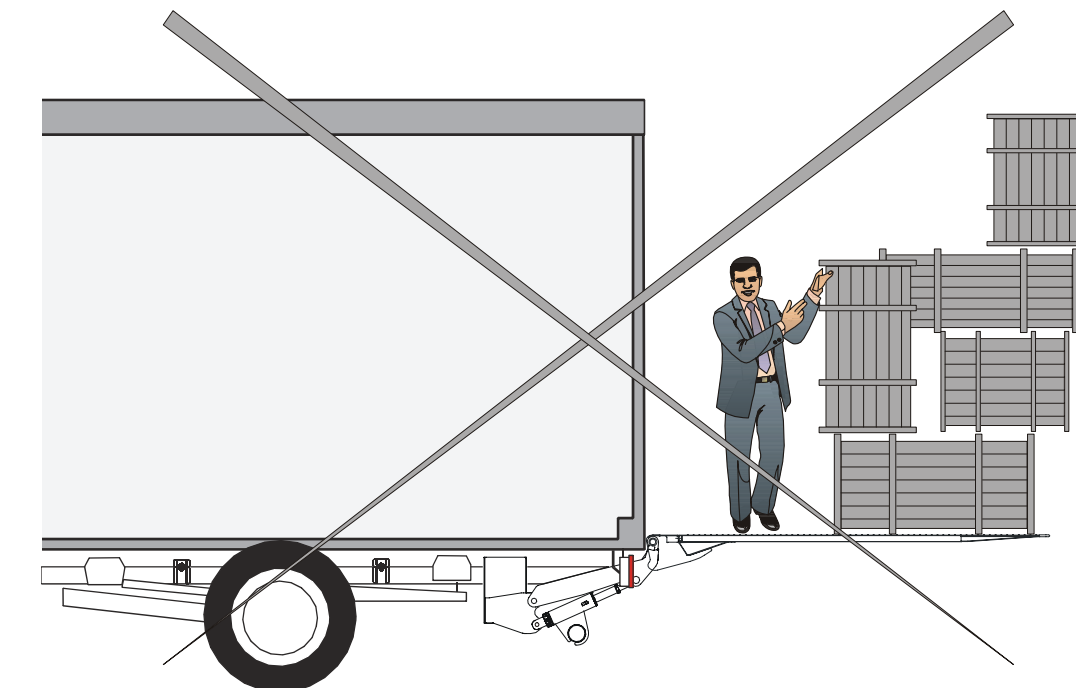

Secure the load against toppling over and sliding

Permissible Loading

Apart from being included in these operating instructions, the load diagram is also shown on the lift gate identification plate. All loads must be placed as close to the edge of the Platform nearest to the vehicle floor as possible, with the heaviest part of the load toward the vehicle. No part of any load should be allowed to extend over the edges of the Platform. Do not place unstable loads on the Platform. Do not allow any load to exceed the rated capacity for the unit. If standing on the Platform, do not allow your feet to protrude beyond the edges. The greater the distance of the load from the vehicle floor, the lower the loading capacity. The maximum loading capacity specified in the load diagram must not be exceeded. The platform may not be permitted carrying used with any load greater than the maximum capacity.

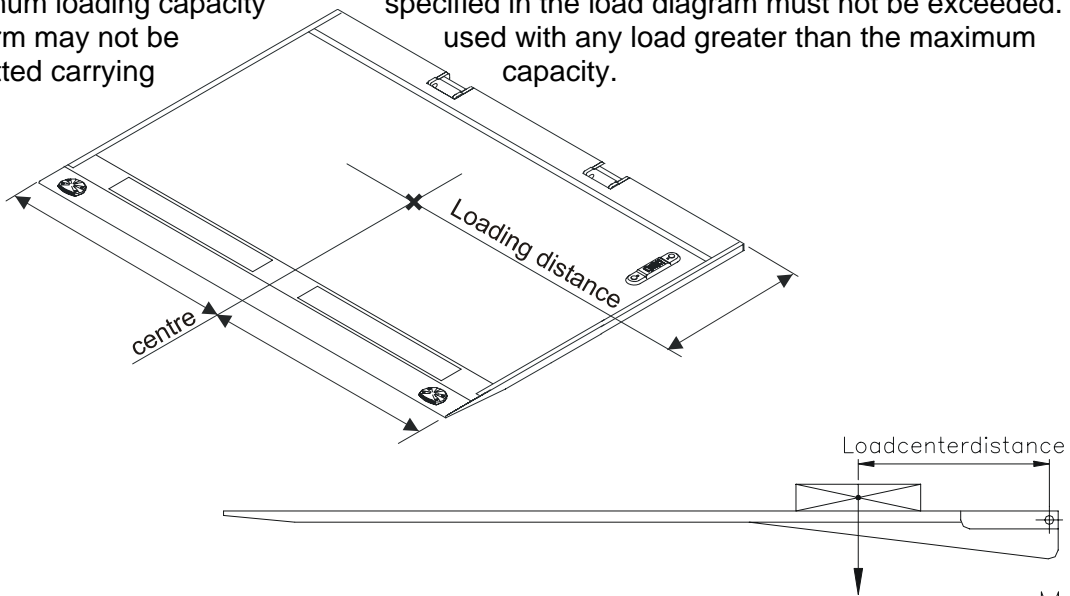

Model

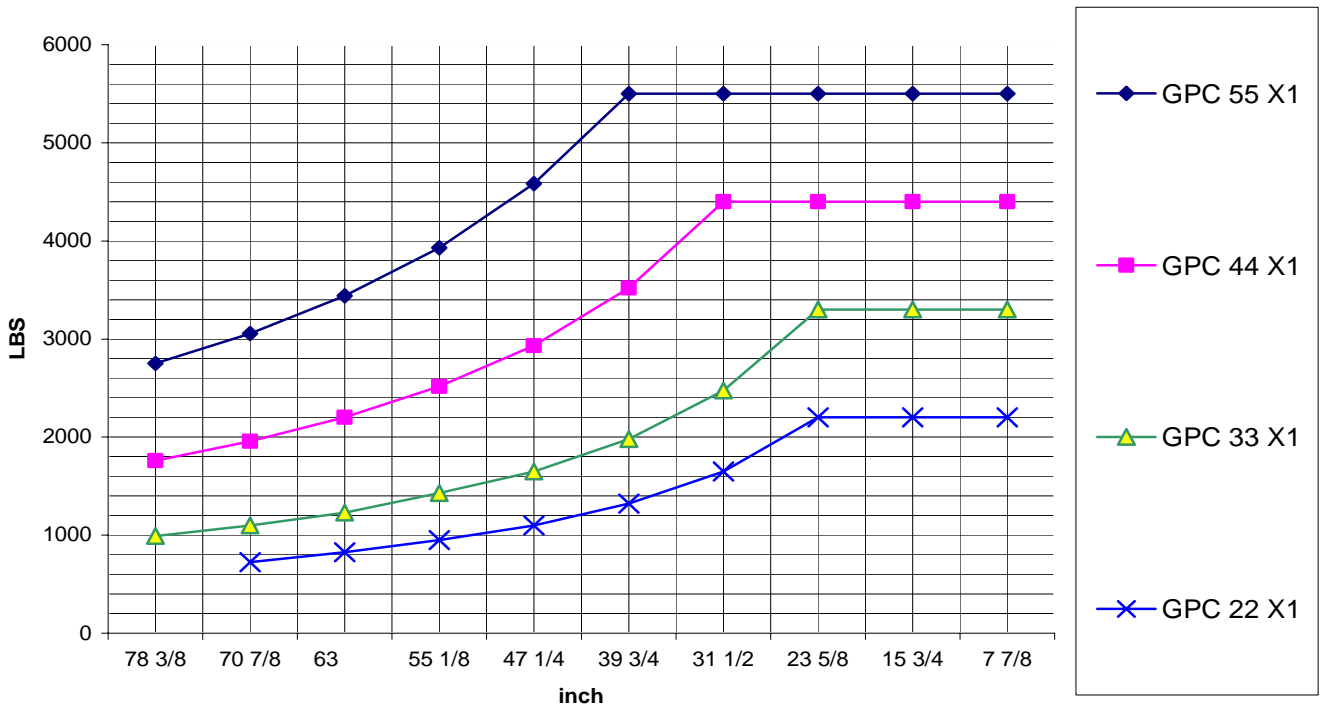

Platform, bridge and ramp

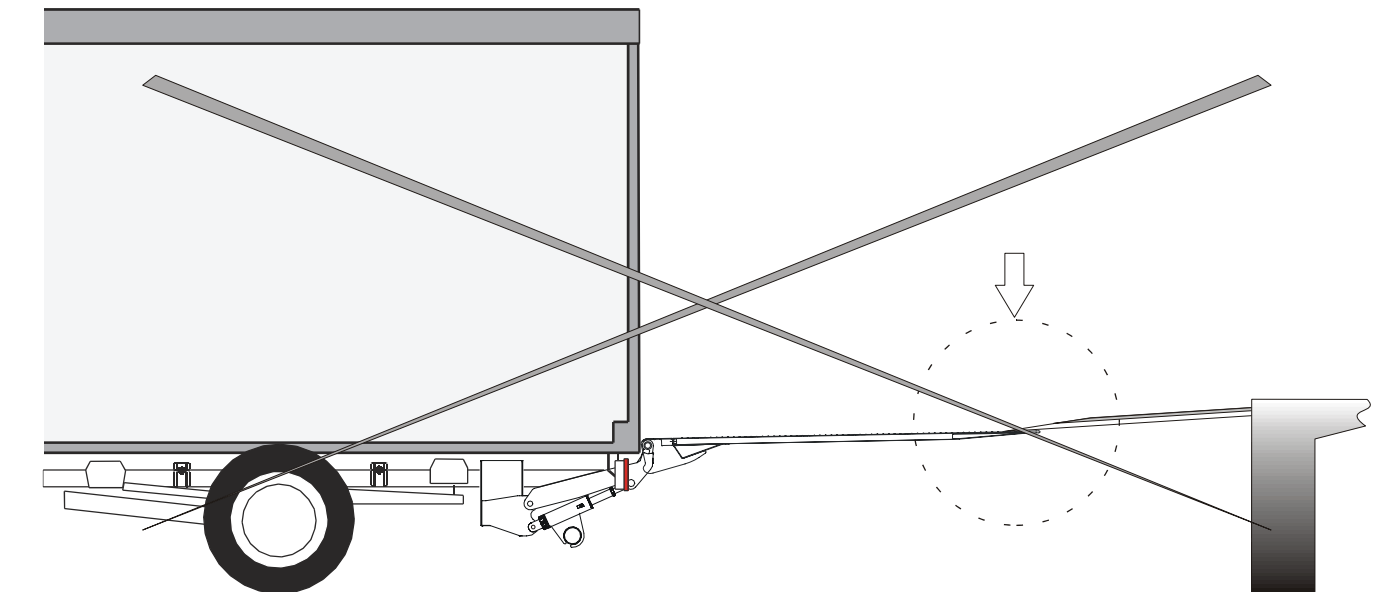

Never sit the ramp on the platform, always use the platform as a ramp !

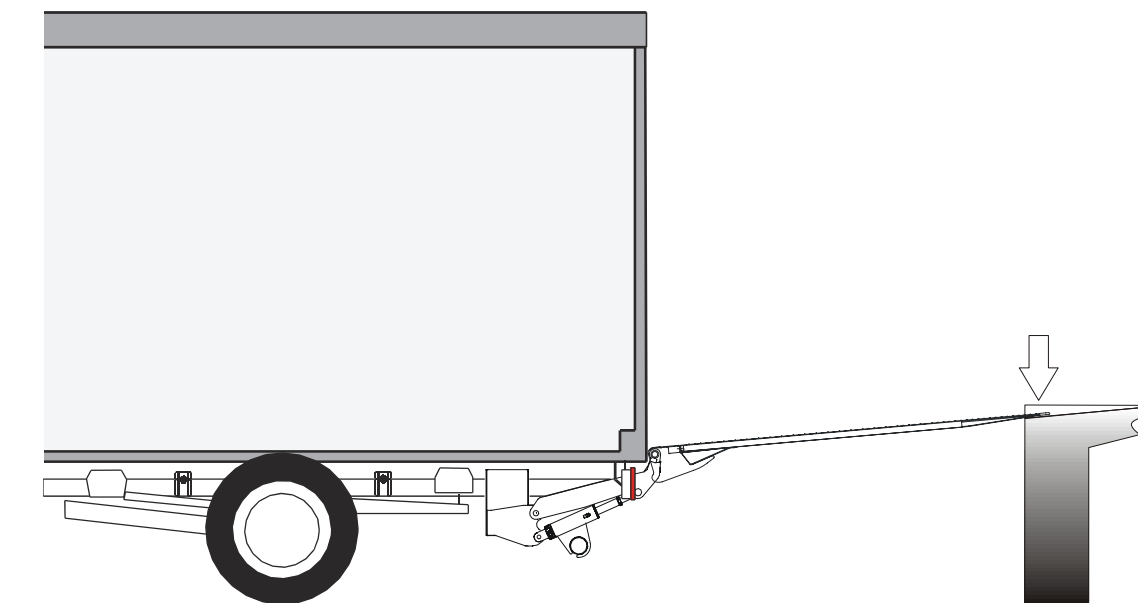

Load and unload at a ramp

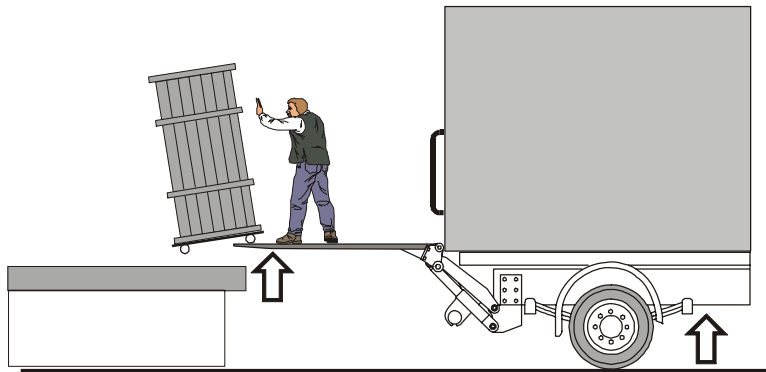

Loading and unloading at a ramp is only possible if the platform tip sits firmly on the dock. Please note that the vehicle might lift while unloading, and that the platform will lift from the ground. To prevent accidents, the platform tilt must always be compensated, so that the tip sits firmly on the dock at all times.

Transferring Loads from Vehicle to Vehicle

When transferring loads, it should be ensured that only one of the two platforms is being used as a dock. The platform being used as a dock must lie firmly on the vehicle opposite, or it may lead to the lift gate becoming overloaded.

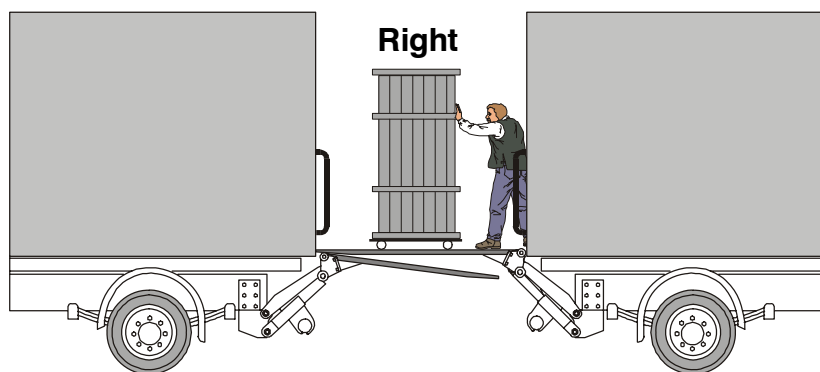
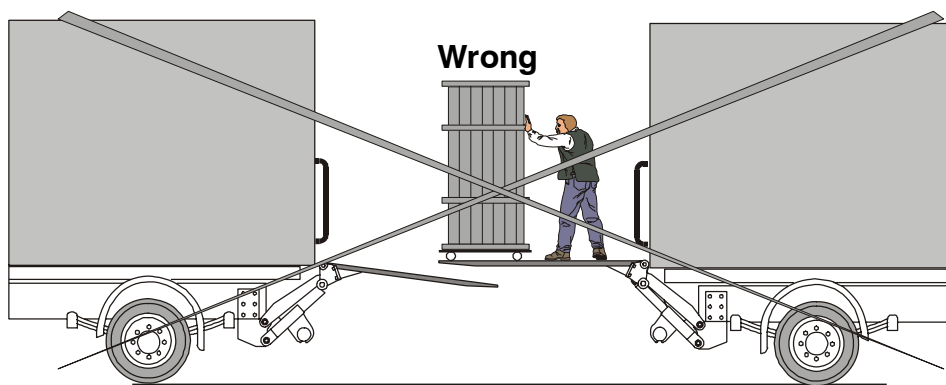

Loading with a Fork-Lift Truck

Driving over the platform with a fork-lift truck is not allowed if the weight of the fork-lift plus the weight of the load to be transported is greater than the carrying capacity of the lift gate. The platform must lie firmly on the floor.

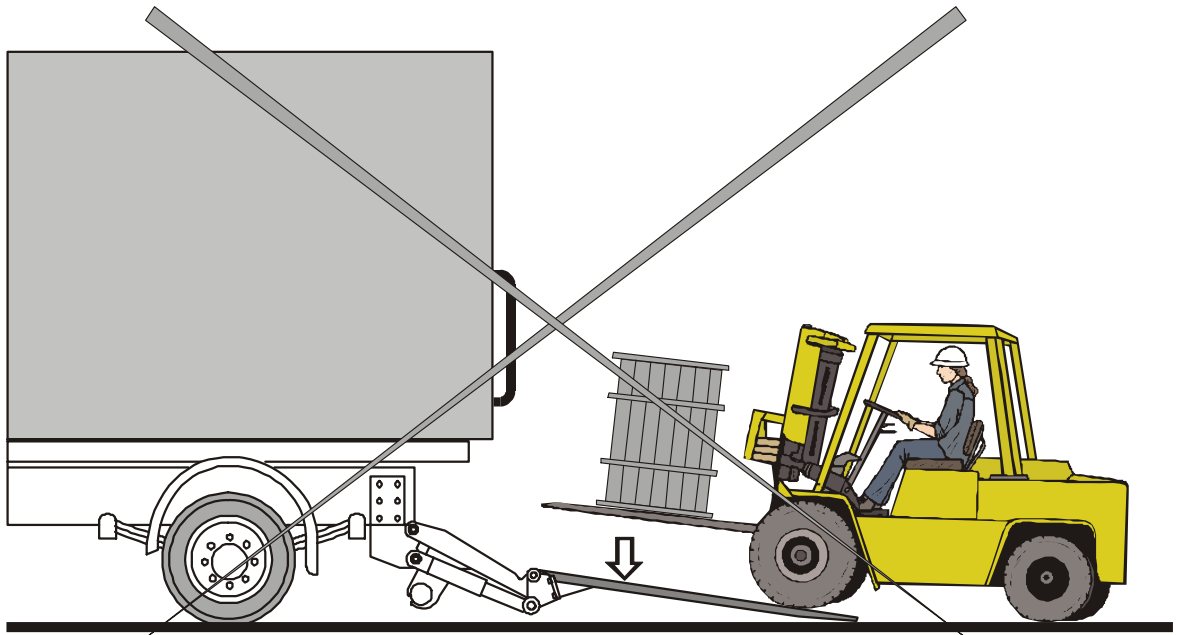

When performing any kind of loading or unloading operation, the vehicle must be secured against unexpected movement. Use handbrake or wedges

Securing of Load

The use of the platform or any other parts of the lift gate as a means of securing a load is not permitted.

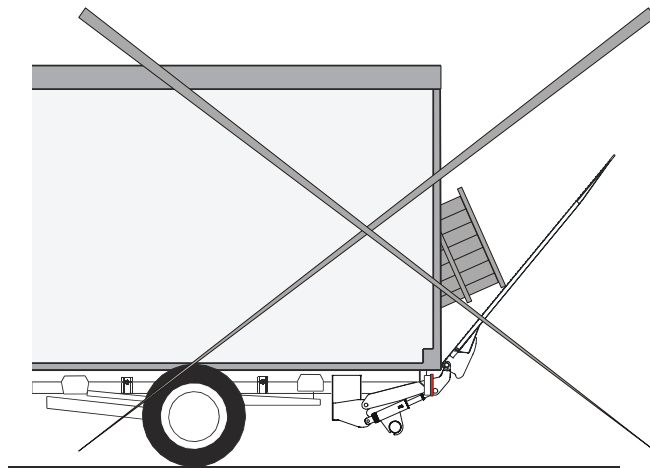

Only close the platform after the lift arms have moved firmly against the bodywork. Under no circumstances close the platform on the floor or in an intermediate position. This will destroy cylinders, cables and mechanical parts.

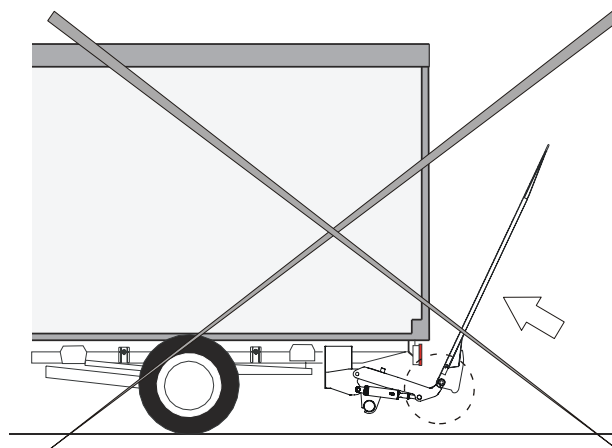

Lift gate as lifting device

Do not hand any loads on the platform

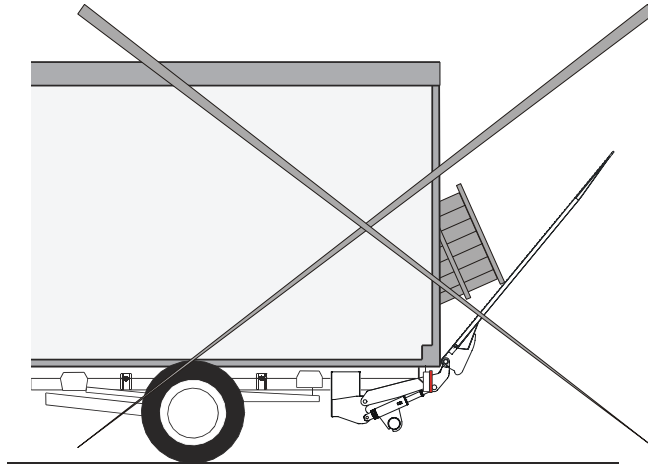

Lift gate as pushing device

Do not use the lift gate as a pushing device

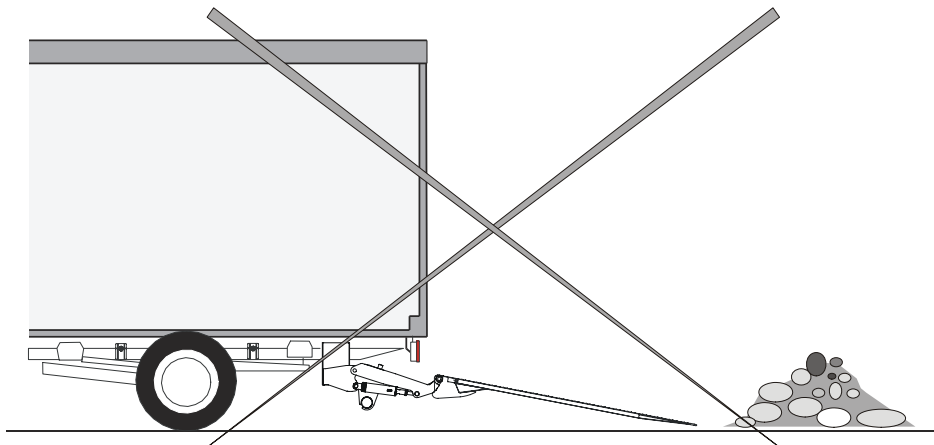

Care, Maintenance, Testing and Repairs

Before the start of maintenance work, the lift gate must be secured against unforeseen movement.

The lift gate is very undemanding. It should, however, be included in the regular servicing work on the vehicle.

Check that all screw connections are tight. Check that cables and hoses are able to move freely. Correct shearing and chafing points on cables and hoses. Immediately replace damaged hydraulic hoses with ones of the same quality. Note the replacement in the inspection records.

During cleaning it should be ensured that no moisture penetrates the power pack or the control box. The bearing areas should not be cleaned with high pressure or steam jets, as this may allow dirt and moisture to penetrate the bearing.

Check the hydraulic unit for leaks. With the lift gate lowered, check the oil level with the platform lowered to the ground in the unit's tank (dipstick on the oil filler neck cover). The maximum oil level has been reached when the dipstick dips approx. one centimetre into the oil.

Carry out an annual oil change and clean the suction filter. Carry out the oil change before any period of frost, in order to prevent the hydraulic unit from freezing up.

Hydraulic oil – recommendations

| ISO 32 HYDRAULIC OIL | | ISO 15 HYDRAULIC OIL | | ISO-10 OR MIL-H-5606 Hydraulic Oil | |
|----------------------|-----------------------------------|----------------------|-------------------|------------------------------------|--------------------|
| AMSOIL | AWH-05 | AMSOIL | AWF-05 | AMSOIL | N/A |
| CHEVRON | HIPERSYN 32 | CHEVRON | FLUID A, AW-MV-15 | CHEVRON | FLUID A, FLUID G |
| KENDALL | GOLDEN MV | KENDALL | GLACIAL BLU | KENDALL | GLACIAL BLU |
| SHELL | TELLUS T-32 | SHELL | TELLUS T-15 | SHELL | AEROSHELL FLUID-41 |
| EXXON | UNIVIS N-32 | EXXON | UNIVIS HVI-1 | EXXON | UNIVIS HVI-13 |
| MOBIL | DTE-13M, DTE-24, HYDRAULIC OIL-13 | MOBIL | DTE-11M | MOBIL | AERO HFA |

With normal temperatures from 15 to 85 degree Fahrenheit it is recommended to use ISO 15 Hydraulic oil. For general colder climate use ISO 10, and warmer climate use ISO 32.

Oil fill up or change

1. lower
2. tilt down
3. oil fill up

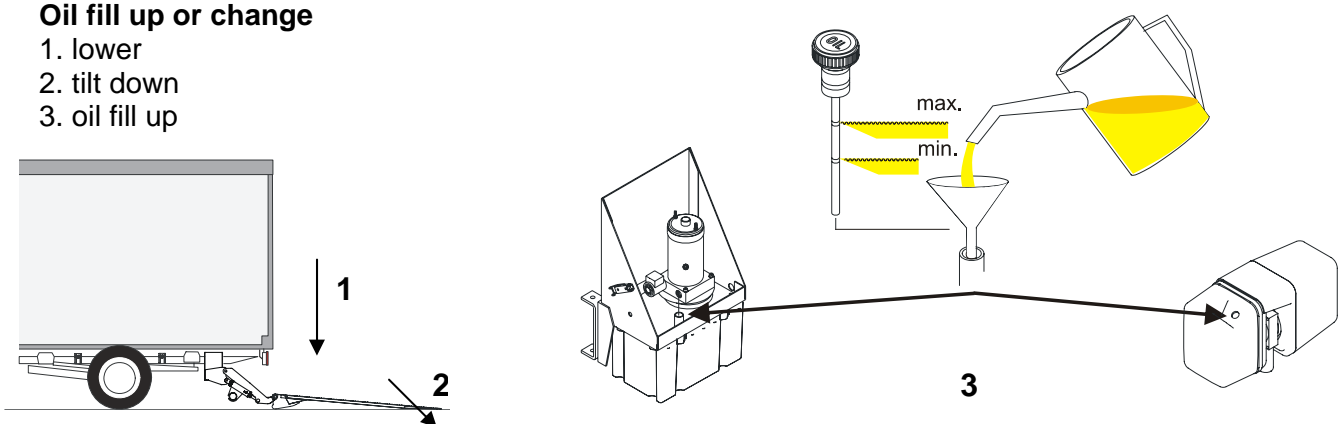

Repairs to Load-Bearing Components

Repairs to load-bearing components are only to be carried out in an authorized repair shop and are to be tested by a competent person and entered in the inspection records.

For any malfunctioning, first check voltage level

Troubleshooting

The 2 diodes in the front of the control box lits when the GPC are switched on. If not - check the fuse in the battery cable.

| Problem | possible cause |
|--|---|
| 1. Motor of pump box does not work | Battery cable or ground cable not connected or defective or empty battery |
| | Main fuse defective Fuse in power pack defective |
| | The power relay is defective and doesn't switch |
| | Motor defective |
| 2. Motor does not work on one function only | Toggleswitch on hand control box defective |
| | Cable from hand control box to pump box defective |
| | Wiring inside pump box defective |
| | Switch relay defective (Starter Solenoid) |
| 3. Platform tilts down alone without operating that function. | Solenoid valves on tilting cylinder defective Cylinder defective |
| 4. Platform does not tilt down when touching the ground. | Cable to pressure switch defective |
| | Pressure switch defective |
| 5. Lift gate does not lift | Pump box does not work |
| | Lack of oil in the tank |
| | Voltage insufficient (low Battery) |
| 6. Lift gate does not lift rated capacity | Load is placed in excess of permitted loading distance |
| | Weight of load too high |
| | Overload security valve not set properly |

| | |
|--|--|
| | Pump defective |
| | Voltage insufficient (low Battery) |
| 7. Lift gate does not tilt up from ground when unloaded | Toggle switch does not operate |
| | Mercury switch S2 defective or not set properly |
| 8. Lift gate does not tilt up from ground when loaded. | Load is placed in excess of permitted loading distance |
| | Weight of load too high |
| | Overload security valve not set properly |
| 9. Lift gate tilts from ground above horizontal | Mercury switch S2 defective or not set properly |

Where the electrical motor runs continuously (the lift gate will not switch off) disconnect the positive cable from the battery by disconnecting the main switch or throwing the main fuse.

In an emergency call our Customer Service Department or the nearest authorized repair shop. On request, we shall be pleased to send you an up-to-date list of Customer Service repair shops authorised by us.

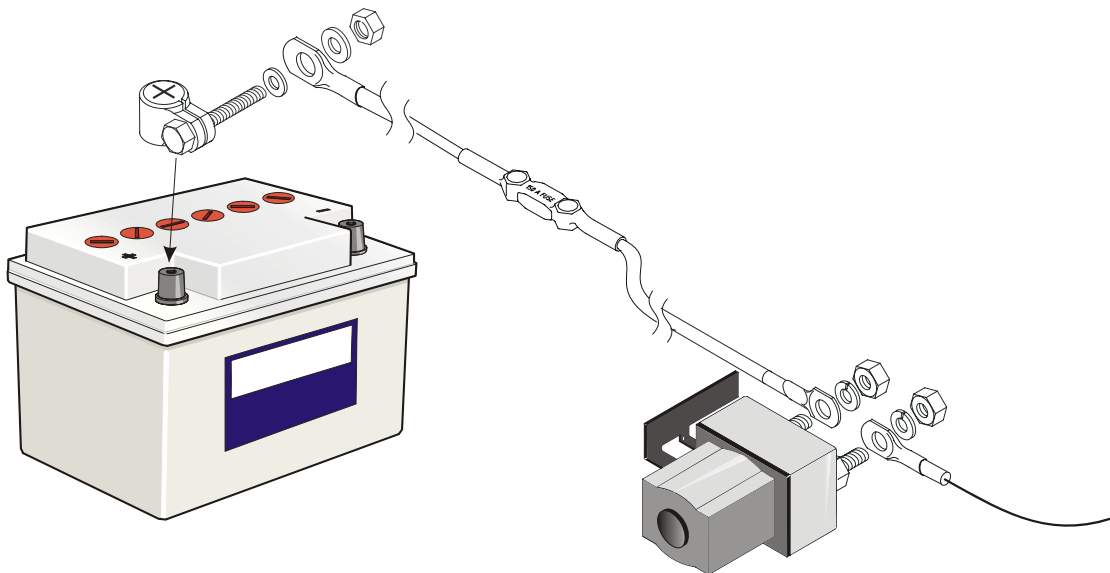

In an Emergency

If, in an emergency, the lift gate is raised or closed manually or by mechanical means instead of hydraulically, the hydraulic cylinders are filled with air. The safety valves are not operational in this case. This means that removal of any rope, chain or other means being used to hold lift in the raised position can be extremely dangerous and even fatal, as the lift gate will freefall to the floor without any braking mechanism.

In such a case secure the lift gate by means of ropes or chains and attach a clear notice to it:

Caution ! Life danger ! The Lift gate is unsecured and must be operated only by trained personnel !

Operation failure

In case of failure, please contact our customers service or the next authorized service dealer.

We will provide an up-to-date list of service dealers on request

Contact Maxon Technical Service at 1-800-227-4116 or by fax 888-771-7713

Warranty

LIFT CORP.

11921 Slauson Ave.

Santa Fe Springs, CA. 90670

CUSTOMER SERVICE:

(562) 464-0099

(800) 227-4116

FAX: (888) 771-7713

TECHNICAL SERVICE:

(800) 8-MAXTEK (862-9835)

WARRANTY POLICY & PROCEDURE

NEW LIFT GATE WARRANTY

Term of Warranty: 2 Years from Date of In-Service

Type of Warranty: Full Parts and Labor

MAXON agrees to replace any components which are found to be defective during the first 2 years of service, and will reimburse for labor based on Maxon's Lift gate Warranty Flat Rate

Labor Schedule.

All claims for warranty must be received within 30 Days of the repair date, and include the following information:

1. Lift gate Model Number
2. Lift gate Serial Number
3. Description of Problem
4. Corrective Action Taken, and Date of Repair.
5. Parts used for Repair, Including MAXON Part Number(s).
6. MAXON R.G.A. # and/or Authorization # if applicable (see below).
7. Person contacted at MAXON if applicable.

PURCHASE PART WARRANTY

Term of Warranty: 1 Year from Date of Purchase Type of Warranty: Part Replacement and Replacement Labor

MAXON will guarantee all returned genuine replacement parts upon receipt, and inspection of parts and invoice. All Warranty repairs must be performed by an authorized MAXON warranty station.

For major repairs, Maxon's Warranty Department must be notified, and an "Authorization

Number” received. Major repairs would generally be considered repairs made to the structural assembly of the lift gate and/or repairs not outlined in the Maxon Slidelift Warranty Flat Rate Schedule.

Major components (i.e. hydraulic pumps, cylinders, valves, or failed structural parts) must be returned, freight pre-paid, prior to the claim being processed. To ensure timely processing of these warranty claims, an R.G.A. (Returned Goods Authorization) number must be obtained from

Maxon’s Warranty Department prior to the return of any defective part. Defective Parts must be returned within 60 days of the claim date for consideration to:

Warranty Department, MAXON Lift Corp.

16205 Distribution Way, Cerritos, California. 90703

Maxon’s warranty policy does not include the reimbursement for travel time; towing; vehicle rental; service calls; fabrication of parts which are available from MAXON; oil; defects due to misuse or abuse; loss of income due to downtime.

Maxon’s Flat Rate Labor Schedule times takes into consideration time required for diagnosis of problem.

Warranty and Technical Information is available by calling Maxon’s Customer Service Department.

NOTE: Check with Customer Service Department for updated versions of Manuals on an annual basis.

Liability exclusions

Our liability excludes : damages assigned to wrong installation or operation of the slidelift, overloading, improper use, insufficient battery charge or capacity, accidents or damages due to ground contact (e.g. rough terrain at building sites)

Decals

These Decals should be read and completely understood before operating the unit. They should also be kept clean and readable at all times. If any decals should become detached from the vehicles, or defaced, it must be replaced. Free replacement are available from: MAXON Lift Corp., Parts Department.

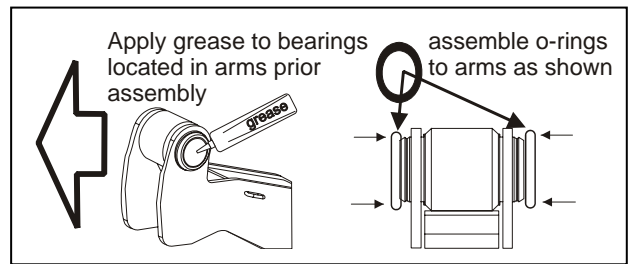

max. bed hight

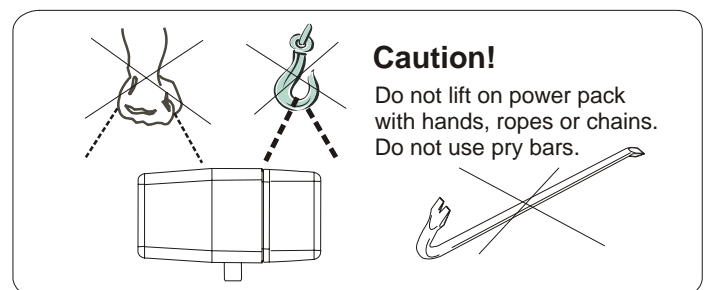
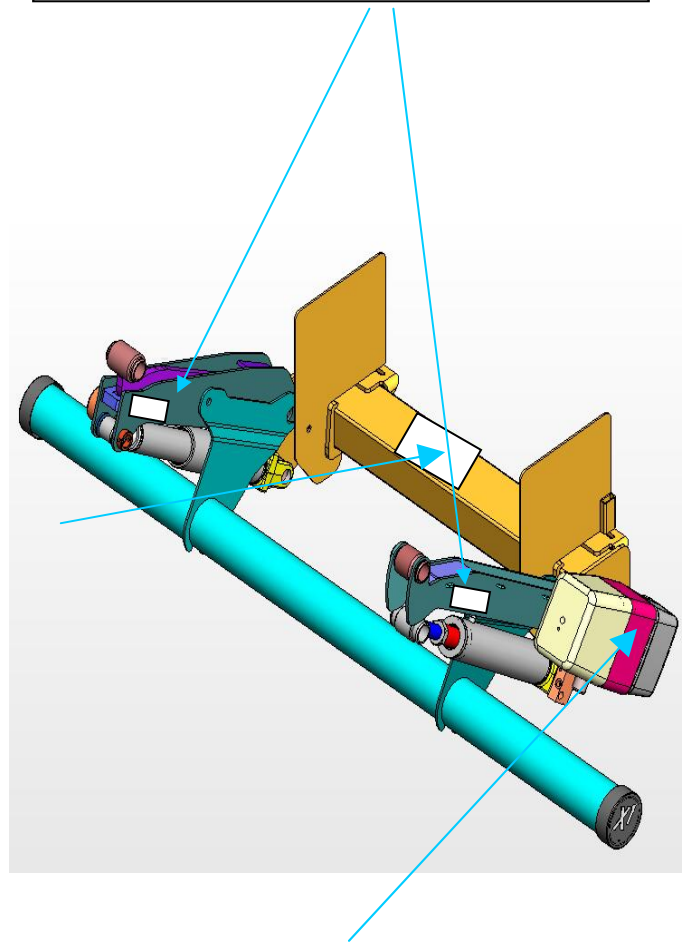
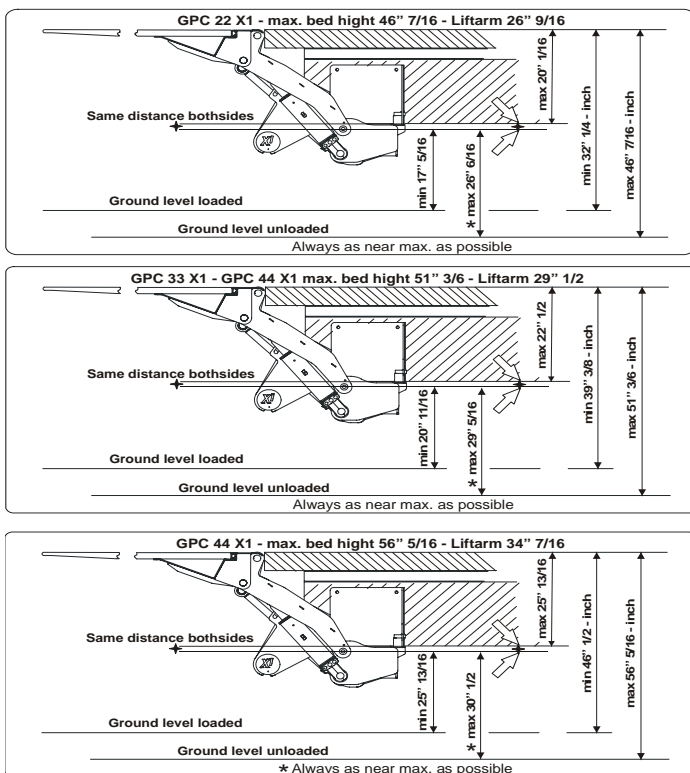

MAXON[®] Lift CORP.

GPC 22X1



THE MAXIMUM CAPACITY OF THIS LIFT IS
2200 POUNDS

GPC 33X1



THE MAXIMUM CAPACITY OF THIS LIFT IS
3300 POUNDS

GPC 44X1



THE MAXIMUM CAPACITY OF THIS LIFT IS
4400 POUNDS

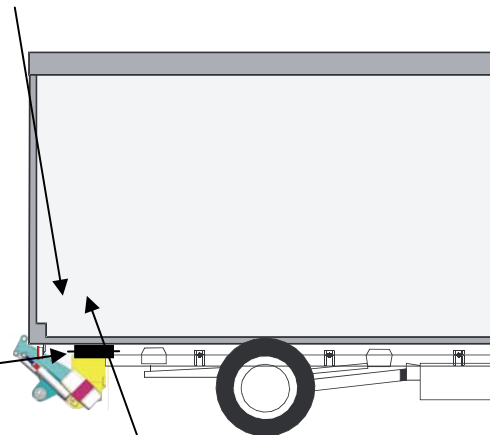

CAUTION
STAND CLEAR
WHEN OPERATING

50092

WARNING
TILT THE PLATFORM TO LEVEL POSITION PRIOR TO RAISING

WARNING
READ CAREFULLY

- Improper operation of this Lift can result in serious personal injury. Do not operate unless you have been properly instructed and have read, and are familiar with the operating instructions. If you do not have a copy of the instructions, please obtain them from your employer, distributor, or lessor, before you attempt to operate Lift
- Be certain that the vehicle is properly and securely braked before using the Lift
- Always inspect this Lift for maintenance or damage before using it. If there are signs of improper maintenance, damage to vital parts, or slippery Platform surface, do not use the Lift until these problems have been corrected
- Do not overload the Lift. The load limit is based on evenly distributed cargo over the entire Platform surface. If you are using a pallet jack, be sure it can be maneuvered safely. Do not operate a forklift on the Platform or travel with the platform in an open position at any time.
- Load should be placed in a stable position close to the edge of the Platform nearest the truck. The heaviest portion of the load should never be placed beyond the center of the Platform away from the truck.
- Never allow yourself, a helper, or bystander to stand in a position where a falling load could land on either of you. Also do not allow any part of yours or your helper body to be placed under, within, or around any portion of the moving liftgate, or it's mechanisms, or in a position that would trap them between the platform and the ground or truck when the liftgate is operated.
- If a helper is riding the Platform with you, make sure you are both doing so safely and that you are not in danger of coming in contact with any moving or potentially moving obstacles. USE GOOD COMMON SENSE. If load appears to be unsafe, do not lift or lower it.

MAXON LIFT CORP. PART NO. 264081

ALL lift gate warning, capacity, and caution decals should be affixed to the truck body in plain view of the operator near the main lift gate Control Station.

Note: The main liftgate Control Station is normally mounted on right rear corner of the truck body.

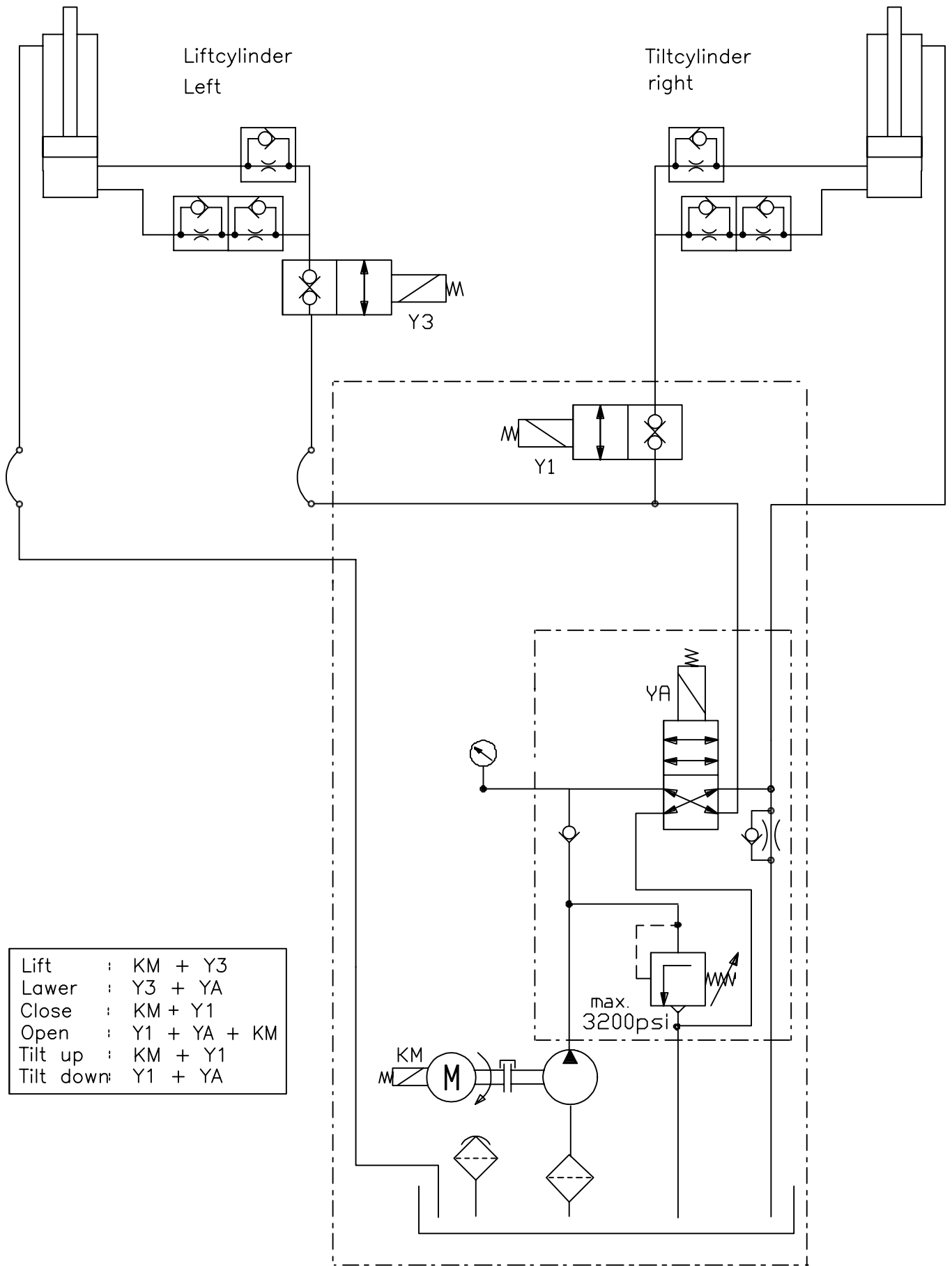

MAXON®

Date: 2004/10/08
Ini: SKC

Nr.: 20 906 971

ON/OFF - Switch

left lamp is out, if "up" is pressed and S2 switched at horizontal platform position.
 left lamp is out also, if "down" is pressed and S4 switched if platform is on ground (lift-cylinder is without pressure).
 right lamp is out, if switch "up" or "down" is pressed on handheld controlbox.

OPTION:
CONTROL-LAMP
 20 905 547

lamp +
 test FH,FS

20 906 863 CONTROL-UNIT 12 V

lamp +
 test S2,S4

Please connect behind the fuse
 No. 30

platform-cable
 20 905 109

- 1- 2- FH
- 3- 4- S2
- 5- 6- S1
- 6- 31

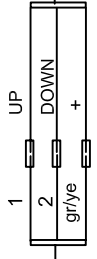
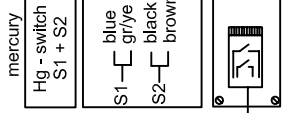

20 906 733
 HANDHELD CONTROLBOX

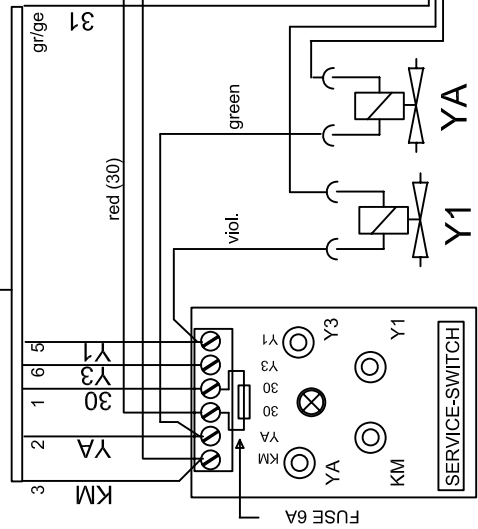

| | KM | YA | Y1 | Y3 | S1 | S2 | S4 |
|-----------|----|----|----|----|----|----|----|
| LIFT | X | | X | | | | |
| TILT-UP | X | X | | | | | |
| LOWER | | X | | | | | |
| TILT DOWN | X | X | X | | | | |
| TILT-UP | X | | X | | X | | |
| LIFT | X | | X | | X | X | |
| LOWER | | X | X | | X | X | |
| TILT-DOWN | | | X | | X | X | X |

- 30 - batteryplus
- 31 - batteryminus
- KM - motorrelay
- YA - solenoid in power-pack
- Y1 - solenoid tilt-cylinder
- Y3 - solenoid lift-cylinder
- S1 - mercury-switch
- S2 - mercury-switch lift
- S4 - pressure-switch tilt down
- Th - motor-thermoswitch



POWER-PACK

control-unit X1

STANDARD 12V GPC

DATUM: 21.07.2004

gcz.: W.Bassen

Nr.: 20 906 864

left lamp is out, if "up" is pressed and S2 switched at horizontal platform position.
 left lamp is out also, if "down" is pressed and S4 switched if platform is on ground (lift-cylinder is without pressure).
 right lamp is out, if switch "up" or "down" is pressed on handheld controlbox.

ON/OFF - Switch

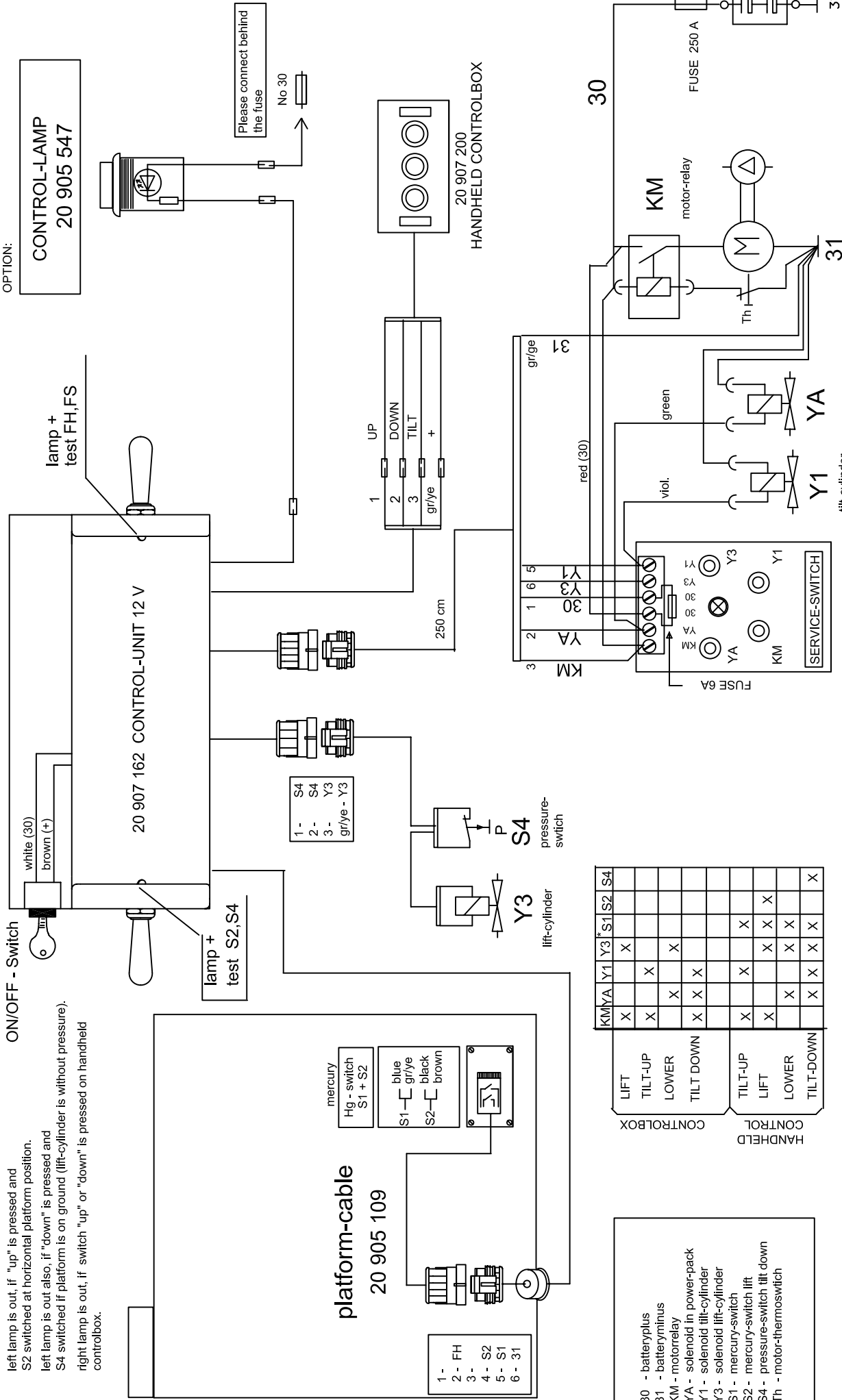

OPTION:

CONTROL-LAMP
20 905 547

lamp +
test FH,FS

20 907 162 CONTROL-UNIT 12 V

lamp +
test S2,S4

1- S4
2- S4
3- Y3
gr/ye - Y3

platform-cable
20 905 109

1-
2- FH
3-
4- S2
5- S1
6- 31

mercury
Hg - switch
S1 + S2
blue
S1 - gr/ye
S2 - black
brown

20 907 200
HANDHELD CONTROLBOX

1 UP
2 DOWN
3 TILT
gr/ye +

| | KM | YA | Y1 | Y3 | S1 | S2 | S4 |
|-----------|----|----|----|----|----|----|----|
| LIFT | X | | | X | | | |
| TILT-UP | X | | X | | | | |
| LOWER | | X | | | | | |
| TILT-DOWN | X | X | | | | | |
| TILT-UP | X | | X | | | | |
| LIFT | X | | X | X | | | |
| LOWER | | X | | X | | | |
| TILT-DOWN | | X | X | | | | X |

30 - batteryplus
 31 - batteryminus
 KM - motorrelay
 YA - solenoid in power-pack
 Y1 - solenoid tilt-cylinder
 Y3 - solenoid lift-cylinder
 S1 - mercury-switch
 S2 - mercury-switch lift
 S4 - pressure-switch tilt down
 Th - motor-thermoswitch

FUSE 250 A

KM
motor-relay

M

Th

green

viol.

red (30)

FUSE 6A

Y1

Y3

YA

YA

YA

YA

YA

YA

Y1
tilt-cylinder

Y3
tilt-cylinder

YA
tilt-cylinder

YA
tilt-cylinder

YA
tilt-cylinder

YA
tilt-cylinder

YA
tilt-cylinder

YA
tilt-cylinder

YA
tilt-cylinder

YA
tilt-cylinder

YA
tilt-cylinder

POWER-PACK

control-unit

STANDARD 12V GPC 22 X1 - GPC 44 X1

DATUM: 16.03.2004

gez.: W.Bassen SOE25130

No.: S 20 907 163

