

M-16-13
REV. C
AUGUST 2017

Installation Manual Contains:

- Warnings & Safety Instructions
- Requirements - Body Strength & Installed Liftgate
- Liftgate Installation Components
- Liftgate Component Installation Instructions
- Hydraulic Fluid Filling Instructions
- Decals
- Hydraulic & Electrical System Diagrams
- Pre-delivery Inspection Form

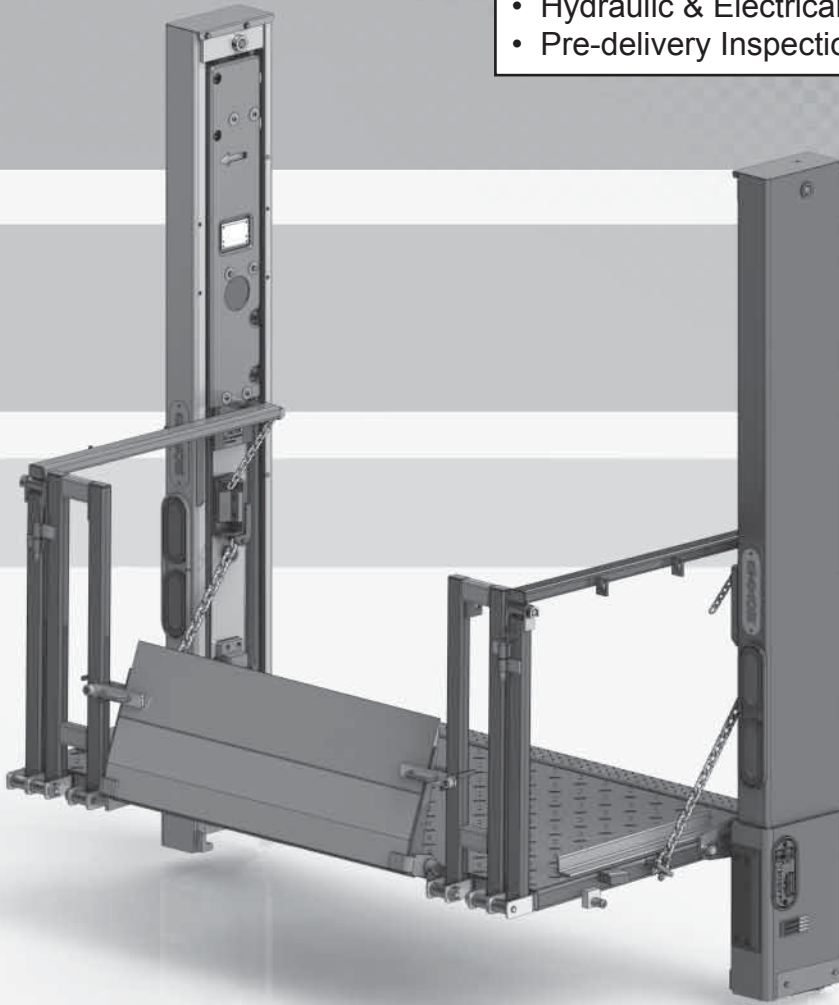

[®]
MAXON
LIFT CORP.

To find maintenance & parts information for your **BMR-CS Liftgate**, go to www.maxonlift.com. Click the **PRODUCTS**, **COLUMNLIFT** & **BMR-CS** buttons. Open the **Maintenance Manual** in the **PRODUCT DOCUMENTATION** window. For parts, click on the **PARTS PORTAL**, **COLUMNLIFT** & **BMR-CS** buttons.

BMR-CS

INSTALLATION MANUAL

TABLE OF CONTENTS

SUMMARY OF CHANGES: M-16-13, REVISION C.....	5
WARNINGS.....	6
SAFETY INSTRUCTIONS	7
VEHICLE REQUIREMENTS	8
BODY STRENGTH.....	8
INSTALLED LIFTGATE	12
LIFTGATE INSTALLATION COMPONENTS.....	13
COMPONENTS.....	14
STEP 1 - PREPARE VEHICLE IF REQUIRED	19
STEP 2 - CHOOSE METHOD OF INSTALLATION.....	21
STEP 3 - POSITION LIFTGATE.....	22
METHOD 1 - PRE-INSTALL MOUNTING PLATES AND EXTENSION PLATE ON VEHICLE.....	22
METHOD 2 - WELD BOLT-ON LIFTGATE TO BODY	27
METHOD 3 - WELD LIFTGATE TO BODY.....	30
STEP 4 - BOLT LIFTGATE TO VEHICLE.....	33
STEP 5 - REMOVE LOWER SUPPORT FIXTURES	38
STEP 6 - POSITION PUMP BOX FRAME	39
STEP 7 - ATTACH PUMP & BATTERY BOX FRAME TO VEHICLE	41
STEP 8 - RUN HYDRAULIC LINES & ELECTRIC CABLES.....	47
RUN GRAVITY DOWN HYDRAULIC LINES	48
TORQUE VALUES FOR HYDRAULIC CONNECTORS.....	50
RUN POWER DOWN HYDRAULIC LINES	51
RUN ELECTRIC CABLES	53
WIRING HARNESS TWIST-LOCK CONNECTORS	54

TABLE OF CONTENTS - Continued

STEP 9 - GROUND PUMP TO VEHICLE FRAME.....	55
STEP 10 - RUN CHARGE LINES	56
RECOMMENDED POWER CONFIGURATIONS	56
RUNNING CABLE FROM VEHICLE BATTERY	58
STEP 11 - CONNECT CHARGE LINES & BATTERIES.....	59
STEP 12 - PRESSURIZE HYDRAULIC SYSTEM	63
STEP 13 - OPTIMIZE HYDRAULIC FLUID LEVEL.....	64
STEP 14 - REMOVE UPPER SUPPORT FIXTURES	69
STEP 15 - SECURING COLUMNS	70
METHOD 1 & METHOD 2	70
METHOD 1 ONLY.....	71
METHOD 1 & METHOD 2	72
STEP 16 - FINISH WELDING LIFTGATE TO VEHICLE	74
METHOD 2 & METHOD 3 - WELD LIFTGATE TO BODY.....	74
STEP 17 - CHECK CLEARANCE OF CONNECTOR BAR SIDE BRACKETS & STOP BLOCKS	78
STEP 18 - CHECK CLEARANCE OF RUNNER PADS	80
STEP 19 - PLATFORM CHAIN ADJUSTMENT	85
STEP 20 - PLACE "ALIGN ARROWS" DECAL	86
DECALS & PLATES	87
TOUCH UP GALVANIZED FINISH	89
HYDRAULIC SYSTEM DIAGRAMS.....	90
PUMP & MOTOR SOLENOID OPERATION - POWER DOWN.....	90
PUMP & MOTOR SOLENOID OPERATION - GRAVITY DOWN.....	91
GRAVITY DOWN HYDRAULIC SCHEMATIC.....	92

TABLE OF CONTENTS - Continued

POWER DOWN HYDRAULIC SCHEMATIC.....	93
ELECTRICAL SYSTEM DIAGRAMS	94
INTERCONNECTING ELECTRICAL SCHEMATIC - GRAVITY DOWN	94
GRAVITY DOWN SINGLE & DUAL PUMP ELECTRICAL SCHEMATIC	95
INTERCONNECTING ELECTRICAL SCHEMATIC - POWER DOWN	96
POWER DOWN SINGLE & DUAL PUMP ELECTRICAL SCHEMATIC	97
BMR ELECTRICAL VALUES.....	98
PRE-DELIVERY INSPECTION FORM.....	99

SUMMARY OF CHANGES: M-16-13, REVISION C

PAGE	DESCRIPTION OF CHANGE
COVER	Updated REV. and date of release.
25	Added information to check flatness of mounting plates against vehicle body before welding.
28, 31	Corrected column squareness dimensions.
55-62	Clarified instructions for grounding pump box, running charge line, and connecting battery power to pump box.
63	Removed instructions to ADD HYDRAULIC FLUID . Liftgate is shipped with hydraulic fluid. The step to OPTIMIZE FLUID LEVEL provides opportunity to add more fluid.
97	Updated coil resistance and ampere values for Bucher pump solenoid valves H, E, C & B. Removed coil pull-in values.

Comply with the following **WARNINGS** and **SAFETY INSTRUCTIONS** while installing Liftgates. See Operation Manual for operating safety requirements.

WARNING

- Do not stand, or allow obstructions, under the platform when lowering the Liftgate. **Be sure your feet are clear of the Liftgate.**
- **Keep fingers, hands, arms, legs, and feet clear of moving Liftgate parts (and platform edges) when operating the Liftgate.**
- **Correctly stow platform when not in use. Extended platforms could create a hazard for people and vehicles passing by.**
- **Make sure vehicle battery power is disconnected** while installing Liftgate. Connect vehicle battery power to the Liftgate only when installation is complete or as required in the installation instructions.
- **Remove all rings, watches and jewelry before doing any electrical work.**
- If it is necessary to stand on the platform while operating the Liftgate, keep your feet and any objects clear of the inboard edge of the platform. Your feet or objects on the platform can become trapped between the platform and the Liftgate extension plate.
- Never perform unauthorized modifications on the Liftgate. Modifications may result in early failure of the Liftgate and may create hazards for Liftgate operators and maintainers.
- Recommended practices for welding on steel parts are contained in the current **AWS (American Welding Society) D1.1 Structural Welding Code - Steel**. Damage to Liftgate and/or vehicle, and personal injury can result from welds that are done incorrectly.
- Recommended practices for welding galvanized steel are contained in the current **AWS (American Welding Society) D19.0 Welding Zinc-Coated Steel**. Damage to Liftgate and/or vehicle, and personal injury can result from welds that are done incorrectly.

SAFETY INSTRUCTIONS

- Read and understand the instructions in this **Installation Manual** before installing Liftgate.
- Before operating the Liftgate, read and understand the operating instructions in **Operation Manual**.
- Comply with all **WARNING** and instruction decals attached to the Liftgate.
- Keep decals clean and legible. If decals are illegible or missing, replace them. Free replacement decals are available from **Maxon Customer Service**.
- Consider the safety and location of bystanders and location of nearby objects when operating the Liftgate. Stand to one side of the platform while operating the Liftgate.
- Do not allow untrained persons or children to operate the Liftgate.
- Wear appropriate safety equipment such as protective eyeglasses, faceshield and clothing while performing maintenance on the Liftgate and handling the battery. Debris from drilling and contact with battery acid may injure unprotected eyes and skin.
- Be careful working by an automotive type battery. Make sure the work area is well ventilated and there are no flames or sparks near the battery. Never lay objects on the battery that can short the terminals together. If battery acid gets in your eyes, immediately seek first aid. If acid gets on your skin, immediately wash it off with soap and water.
- If an emergency situation arises (vehicle or Liftgate) while operating the Liftgate, release the control switch to stop the Liftgate.
- A correctly installed Liftgate operates smoothly and reasonably quiet. The only noticeable noise during operation comes from the power unit while the platform is raised and lowered. Listen for scraping, grating and binding noises and correct the problem before continuing to operate Liftgate.

VEHICLE REQUIREMENTS

NOTE: Installer is responsible for ensuring vehicle meets Federal, State, and Local standards and regulations.

BODY STRENGTH

⚠ WARNING

Consult vehicle body manufacturer for vehicle body strength data. Make sure the forces created by the Liftgate are within the limits prescribed by the vehicle body manufacturer.

NOTE: Maximum operating bed height for body is **56" (Unloaded)**. Minimum bed height is **platform depth plus 5" (Loaded)**. Do not install this Liftgate on vehicle bodies equipped with swing open doors.

The BMR-CS is a body-mounted Liftgate that puts forces on the side walls of truck and trailer bodies (**FIG. 8-1**). For correct installation, truck and trailer bodies must be strong enough to withstand the tension, compression and shear forces shown in **FIG. 8-1**. Use **TABLES 9-1** and **9-2** on the following page to determine the forces that apply to the type of platform, size of platform, and load capacity of your Liftgate.

X= Tension on each sidewall
Y= Compression on each sidewall
Z= Shear on each sidewall

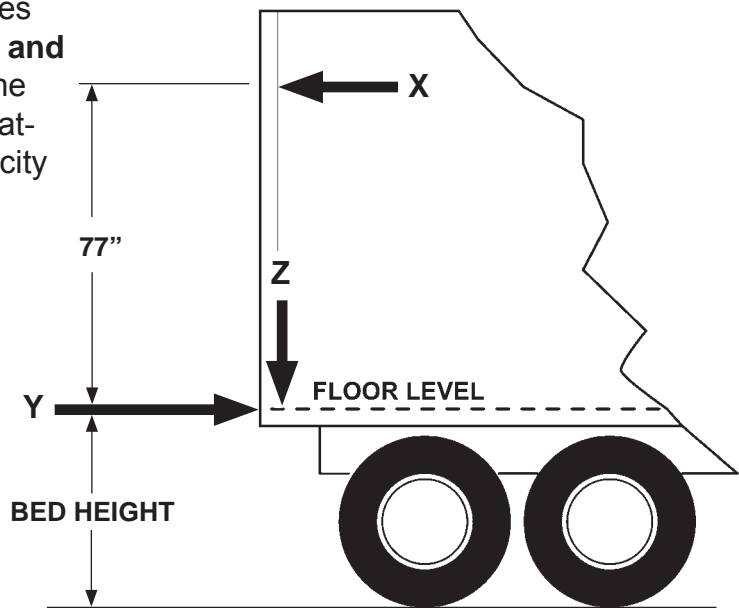

FIG. 8-1

VEHICLE REQUIREMENTS - Continued

BODY STRENGTH - Continued

MODEL CAPACITY	P/F SIZE	(X)(Y) LBS.	(Z) LBS.
BMR-CS35 3500 LBS. (GALVANIZED PLATFORM)	36" & 42"	1043	3786
BMR-CS44 4400 LBS. (GLAVANIZED PLATFORM)	36" & 42"	1262	4461

TABLE 9-1

MODEL CAPACITY	P/F SIZE	(X)(Y) LBS.	(Z) LBS.
BMR-CS35 3500 LBS. (ALUMINUM STD & KNURLED PLATFORM)	36" & 42"	964	3510
BMR-CS44 4400 LBS. (ALUMINUM STD & KNURLED PLATFORM)	36" & 42"	1183	4185

TABLE 9-2

VEHICLE REQUIREMENTS - Continued CLEARANCE DIMENSIONS

NOTE: Maximum bed height is 56" (unloaded).
Minimum bed height (loaded) varies with type and size of platform.
Refer to **FIGS. 10-1 & 10-2.**

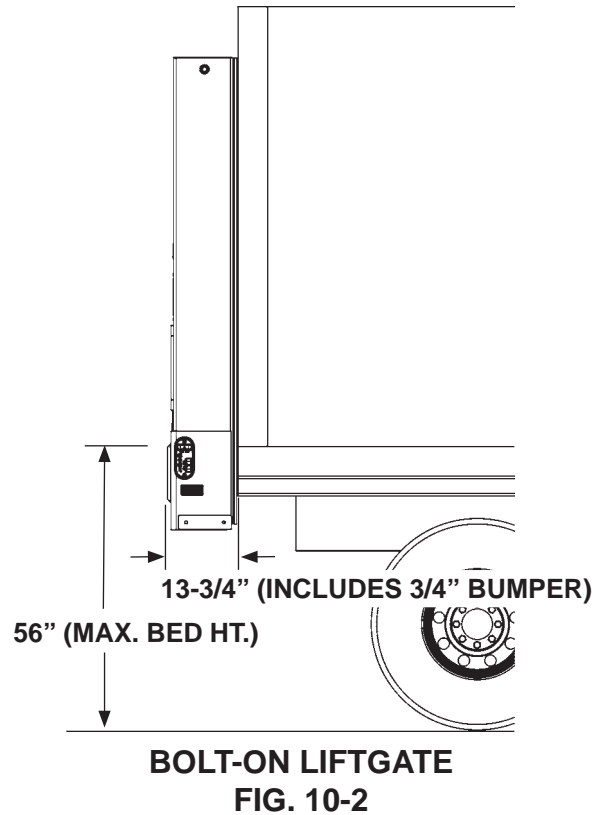
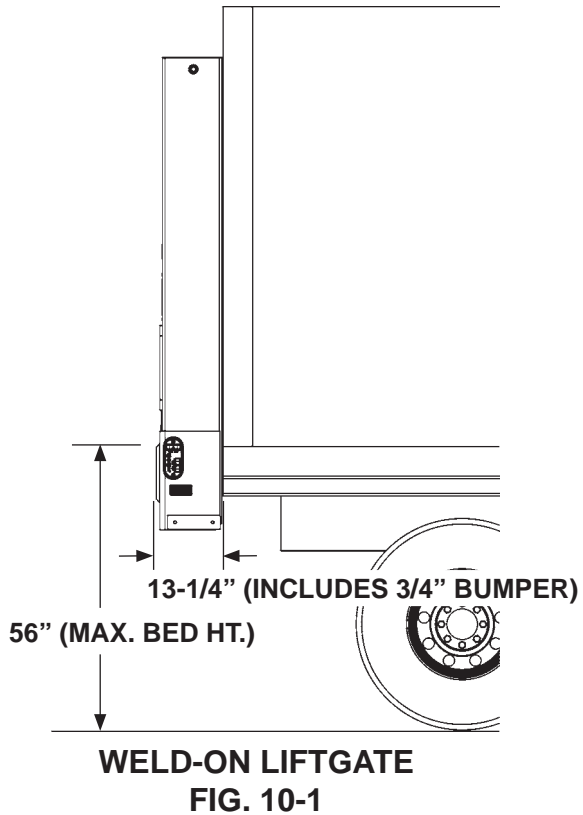

VEHICLE REQUIREMENTS - Continued

CLEARANCE DIMENSIONS - Continued

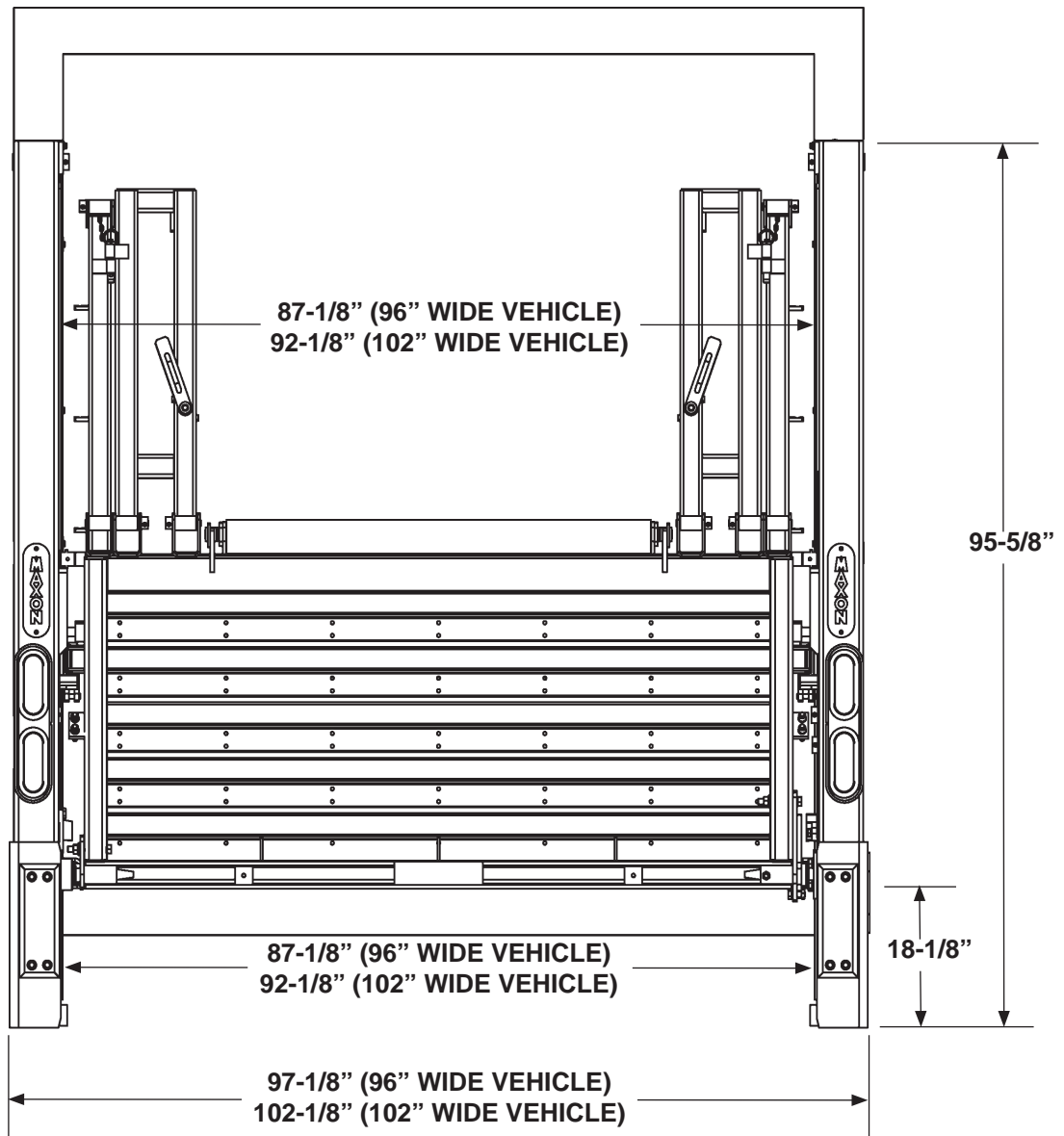

CLEARANCE DIMENSIONS
FIG. 11-1

MAXON® 11921 Slauson Ave. Santa Fe Springs, CA. 90670 (800) 227-4116 FAX (888) 771-7713

VEHICLE REQUIREMENTS - Continued INSTALLED LIFTGATE

NOTE: If Liftgate columns exceed a 91 degree angle from level ground when installed on body, or if columns cannot be mounted flush against rear of vehicle, a steel filler may be used to bridge gap between vehicle body and Liftgate columns. Make sure the added materials and welds meet the **BODY STRENGTH** requirements shown on the previous pages.

With the vehicle parked on level ground, the columns of the BMR-CS must be perpendicular to the ground (vertical) for the Liftgate to operate correctly (FIGS. 12-1 and 12-2).

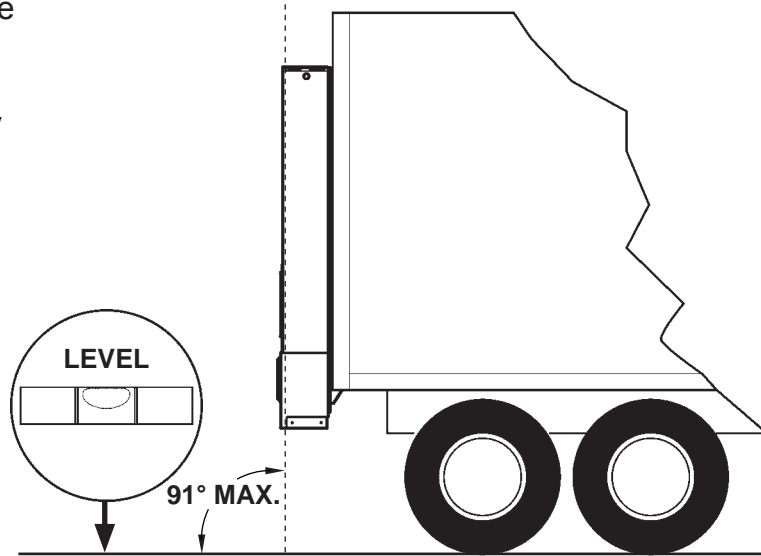

LIFTGATE INSTALLED ON VAN BODY (COLUMNS SHOWN PERPENDICULAR TO LEVEL GROUND)
FIG. 12-1

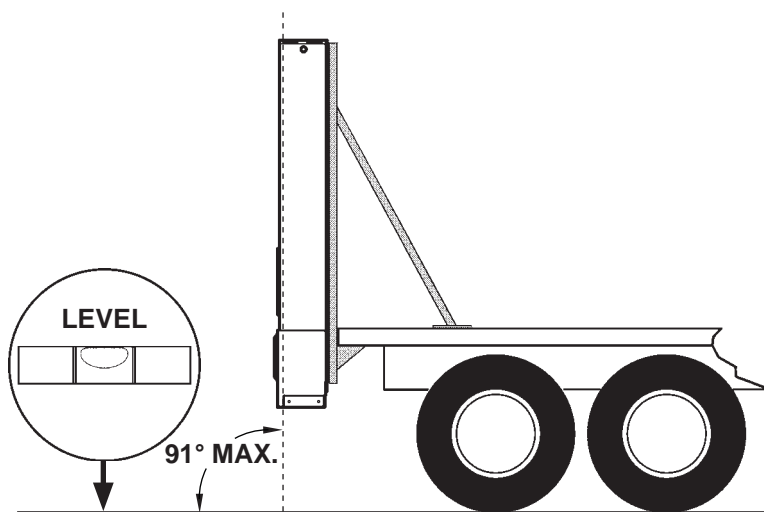

LIFTGATE INSTALLED ON FLAT BED (COLUMNS & SUPPORTS SHOWN PERPENDICULAR TO LEVEL GROUND)
FIG. 12-2

LIFTGATE INSTALLATION COMPONENTS

Each BMR-CS Liftgate includes items shown in **FIG. 13-1**.

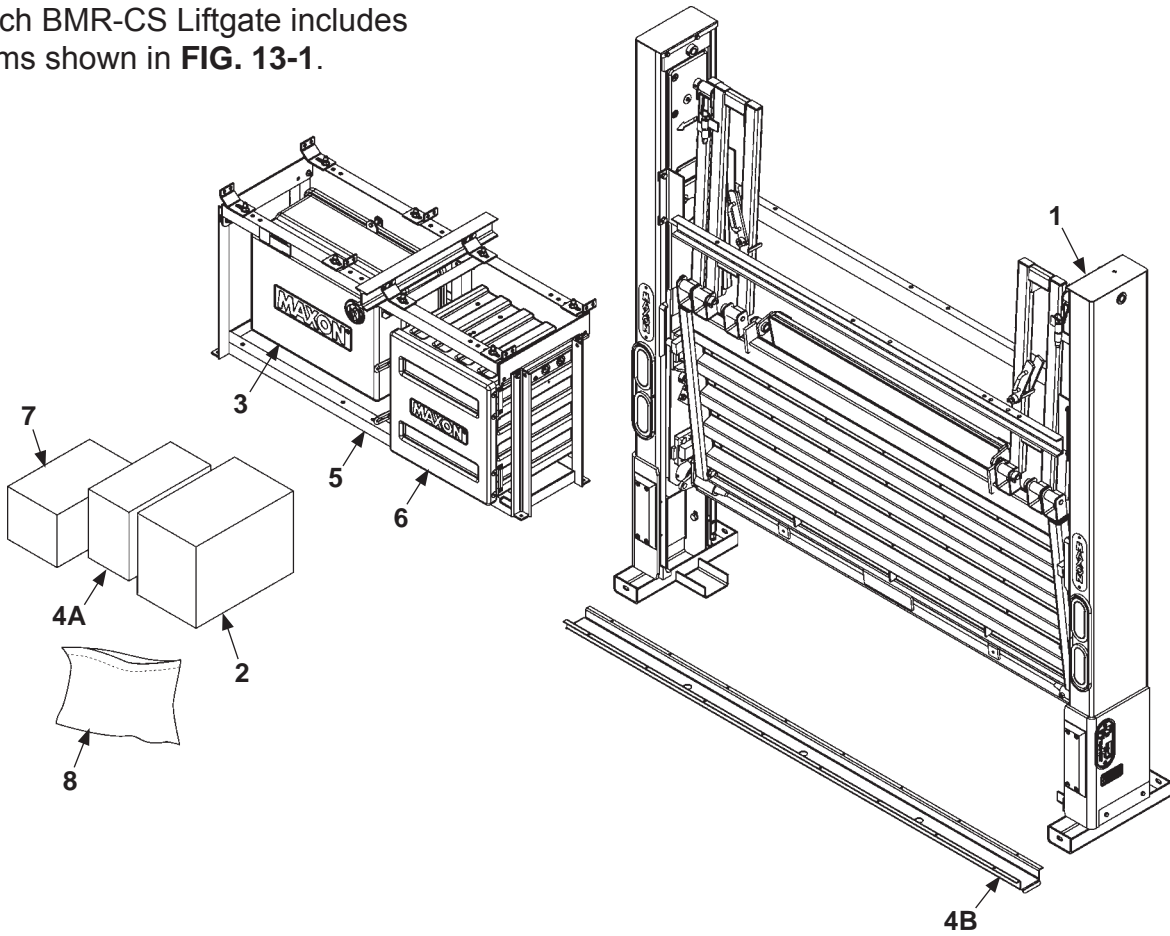

FIG. 13-1

DESCRIPTION	
1	BMR-CS Liftgate.
2	Hardware parts bag, mounting bracket parts bag, hydraulic lines & fittings, wiring harness, power cable, molded switch control box.
3	Pump box assembly.
4A	Pump installation kit (3', 10', 15', 20' or 28').
4B	Channel guard (for 10', 15', 20' or 28' installation kits only)
5	Frame for pump box with optional battery box is shown. A shorter frame is also available for mounting single pump box or an optional battery box.
6	Battery box (optional)
7	Optional equipment
8	Installation and operation manuals.

TABLE 13-1

COMPONENTS

NOTE: Make sure you have components and parts before you start installing Liftgate. Compare parts in the part box and each kit box with packing list enclosed in each box. If parts and components are missing or incorrect, call:

Maxon Customer Service
Call (800) 227-4116 or
Send e-mail to cservice@maxonlift.com

BMR-CS MODEL	KIT, MANUALS	BOLT-ON INSTALLATION KIT, STAINLESS STEEL	BOLT-ON INSTALLATION KIT, STEEL	BOLT-ON INSTALLATION KIT, STEEL (BLACK)
ALL	296909-01	288875-111 (96" WIDE VEHICLE)	288875-101 (96" WIDE VEHICLE)	288875-131 (96" WIDE VEHICLE)
		288875-112 (102" WIDE VEHICLE)		288875-132 (102" WIDE VEHICLE)
		288875-111-150 (96" WIDE VEHICLE)		288875-131-150 (96" WIDE VEHICLE)
		288875-112-150 (102" WIDE VEHICLE)		288875-132-150 (102" WIDE VEHICLE)

TABLE 14-1

BMR-CS MODEL	PART BOX	3 FT PUMP BOX INSTALL KIT	10 FT PUMP BOX INSTALL KIT	15 FT PUMP BOX INSTALL KIT	20 FT PUMP BOX INSTALL KIT	28 FT PUMP BOX INSTALL KIT
BMR-CS35 PD BMR-CS44 PD	296805-02 (WELD-ON)	297060-11	297060-12	297060-13	297060-14	297060-15
	296805-12 (BOLT-ON)					
	296805-12-150 (BOLT-ON)					
BMR-CS35 GD BMR-CS44 GD	296805-01 (WELD-ON)	297060-01	297060-02	297060-03	297060-04	297060-05
	296805-11 (BOLT-ON)					
	296805-11-150 (BOLT-ON)					

TABLE 14-2

MAXON[®] 11921 Slauson Ave. Santa Fe Springs, CA. 90670 (800) 227-4116 FAX (888) 771-7713

COMPONENTS - Continued

BMR-CS MODEL	OPTIONS					
	SINGLE PUMP ASSY	SECOND PUMP KIT	HYDRAULIC OIL UNIVIS HVI-13	FRAME, PUMP OR BATTERY BOXES	HEADER KIT (ADJUSTABLE)	HEADER KIT (RECESSED DOME LAMP)
BMR-CS35 GD BMR-CS44 GD	296190-12	296445-12	284098-01	288180-11G SINGLE FRAME (GALVANIZED)	289190-02 (GALVANIZED)	289188-11 (GALVANIZED, 96" WIDE VE- HICLE)
BMR-CS35 PD BMR-CS44 PD				296180-12		287980-11G DUAL FRAME 2 BATT BOX (GALVANIZED)
				288810-11G DUAL FRAME 3 BATT BOX (GALVANIZED)		

TABLE 15-1

BMR-CS MODEL	OPTIONS				
	DOMELAMP RECESSED MOUNT	DOMELAMP TIMER SWITCH	AUXILIARY CONTROL	HAND HELD CONTROL	CYCLE COUNTER
BMR-CS35 GD BMR-CS44 GD	906589-01-100 (ONLY FOR HEADER KITS WITH RECESSED MOUNTS FOR DOMELAMPS)	295880-01 3' REACH	297080-11	296169-01	289537-01
BMR-CS35 PD BMR-CS44 PD		295880-02 20' REACH	297080-12		

TABLE 15-2

MAXON[®] 11921 Slauson Ave. Santa Fe Springs, CA. 90670 (800) 227-4116 FAX (888) 771-7713

COMPONENTS - Continued

BMR-CS MODEL	OPTIONS				
	POWER & GROUND CABLES	CONSPICUITY (REFLECTIVE) TAPE	PUMP PRESSURE GAUGE	STREET SIDE CONTROL KIT	CAB CUTOFF SWITCH (TRUCK ONLY)
BMR-CS35 GD BMR-CS44 GD BMR-CS55 GD BMR-CS66 GD	295263-01 BASIC INSTALLATION	295261-01	295895-01	297080-01	297077-01
BMR-CS35 PD BMR-CS44 PD BMR-CS55 PD BMR-CS66 PD	295263-11 EXTENDED INSTALLATION			297080-02	

TABLE 16-1

BMR-CS MODEL	BATTERY BOX & CHARGING OPTIONS			
	BATTERY BOX (BATTERIES NOT INCLUDED)	BATTERY 12V, 1150 CCA, BCI GROUP 31	BATTERY BOX MOUNTING FRAME	TRUCK CHARGE LINE
BMR-CS35 BMR-CS44	269560-01 2 BATTERIES 289988-01 2 BATTERIES (INCLUDES DC-DC CON- VERTER)	907086	287990-01G SINGLE GALVANIZED FRAME FOR 2 BATTERIES	280290
	269950-01 3 BATTERIES		287929-01G SINGLE GALVANIZED FRAME FOR 3 BATTERIES	
	289988-02 BATTERIES (INCLUDES DC-DC CON- VERTER)			

TABLE 16-2

MAXON[®] 11921 Slauson Ave. Santa Fe Springs, CA. 90670 (800) 227-4116 FAX (888) 771-7713

COMPONENTS - Continued

BMR-CS MODEL	BATTERY BOX & CHARGING OPTIONS		
	2/0 AWG CABLE TRUCK CHARGE LINE	TRAILER CHARGE LINE FOR USE WITHOUT TRAIL CHARGER	TRACTOR CHARGE LINE FOR USE WITH OR WITHOUT TRAIL CHARGER
BMR-CS35 BMR-CS44	285860-01	280275-01 SINGLE POLE 280275-02 DUAL POLE 280275-06 SINGLE/DUAL POLE FOR NOSE BOX 280275-08 1/0 AWG DUAL POLE WITH SINGLE NOSE BOX	280275-03 SINGLE POLE 280275-04 DUAL POLE 280275-05 SINGLE & DUAL POLE

TABLE 17-1

BMR-CS MODEL	DIRECT TRAIL CHARGER OPTIONS			
	DIRECT WITH DUAL POLE CONNECTIONS	DIRECT, DUAL COMBINATION CONNECTIONS	DIRECT, 7-WAY CONNECTIONS	DIRECT, REFRIGERATED OR STRAIGHT TRUCK CONNECTIONS
BMR-CS35 BMR-CS44	295219-01 (DIRECT-01)	295220-01 (DIRECT-02)	295211-01 (DIRECT-03)	295972-01 (DIRECT-04)

TABLE 17-2

BMR-CS MODEL	SELECT TRAIL CHARGER OPTIONS			
	SELECT WITH REFRIGERATED & DUAL POLE CONNECTIONS	SELECT WITH DUAL POLE & 7-WAY CONNECTIONS	SELECT WITH DUAL COMBINATION & 7-WAY CONNECTIONS	SELECT WITH DUAL COMBINATION, REFRIGERATED & 7-WAY CONNECTIONS
BMR-CS35 BMR-CS44	295210-01 (SELECT-21)	295217-01 (SELECT-24)	295218-01 (SELECT-25)	296170-01 (SELECT-32)

TABLE 17-3

11921 Slauson Ave. Santa Fe Springs, CA. 90670 (800) 227-4116 FAX (888) 771-7713



COMPONENTS - Continued

BMR-CS MODEL	MISCELLANEOUS OPTIONS			
	200 AMP CIRCUIT BREAKER KIT	150 AMP CIRCUIT BREAKER KIT	BATTERY BOX LOCK KIT (SINGLE FRAME)	BATTERY BOX LOCK KIT (DUAL FRAME)
BMR-CS35 BMR-CS44	296504-200 (WITHOUT BATTERY BOX)	296504-150 (FOR TRUCK APPLICATION & AUXILIARY BATTERY)	295245-02G (BATTERY BOX INSTALLED IN SINGLE FRAME)	295245-01G (BATTERY BOX INSTALLED IN DUAL FRAME WITH PUMP BOX)

TABLE 18-1

BMR-CS MODEL	MISCELLANEOUS OPTIONS		
	DIRECT / SELECT BYPASS	MANUAL HOLDER	BATTERY STATE OF CHARGE INDICATOR
BMR-CS35 BMR-CS44	295221-01 (BYPASSES TRAIL CHARGER OR DISCONNECTS BATTERIES FROM CHARGING SYSTEM)	286328-01 (INSTALLS IN BATTERY BOX)	908171-01-100 (INSTALLS ON BATTERY BOX)

TABLE 18-2

MAXON[®] 11921 Slauson Ave. Santa Fe Springs, CA. 90670 (800) 227-4116 FAX (888) 771-7713

STEP 1 - PREPARE VEHICLE IF REQUIRED

NOTE: Perform the following step for flatbed vehicle body only. If vehicle body is not a flatbed, skip this step.

NOTE: LH and RH supports must be perpendicular to level ground. See **VEHICLE REQUIREMENTS, INSTALLED LIFTGATE.**

NOTE: Materials for support framework are not provided with Liftgate.

⚠ WARNING

Recommended practices for welding on steel parts are contained in the current AWS (American Welding Society) D1.1 Structural Welding Code - Steel. Damage to Liftgate and/or vehicle, and personal injury can result from welds that are done incorrectly.

1. Fabricate framework, as shown in **FIGS. 19-1A, -1B & -1C**, to support Liftgate on a flatbed vehicle. Then, go to the next page for welding instructions.

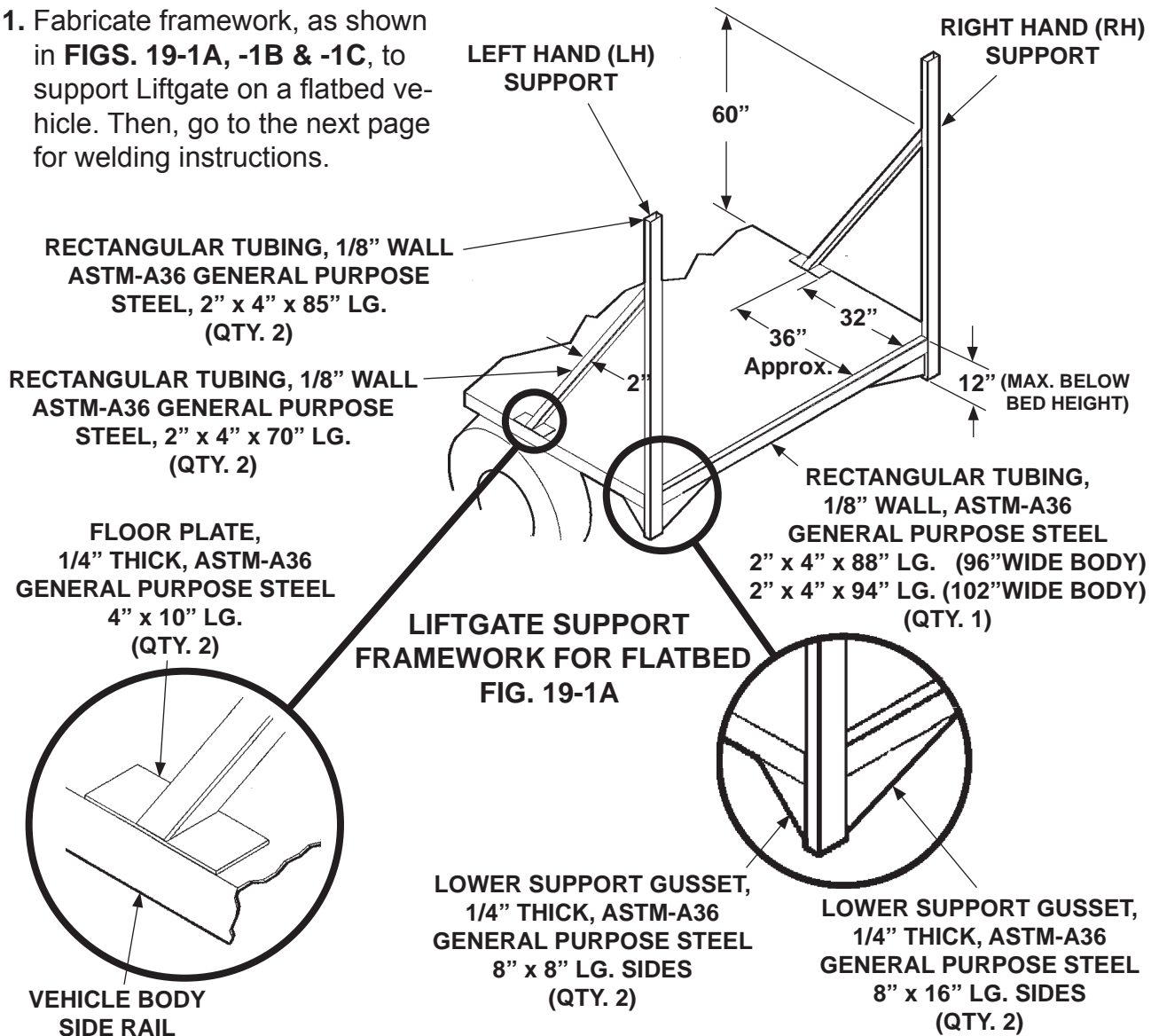

STEP 1 - PREPARE VEHICLE IF REQUIRED - Continued

2. Weld Liftgate supports, as shown in FIGS. 20-1A, -1B, -1C & -1D.

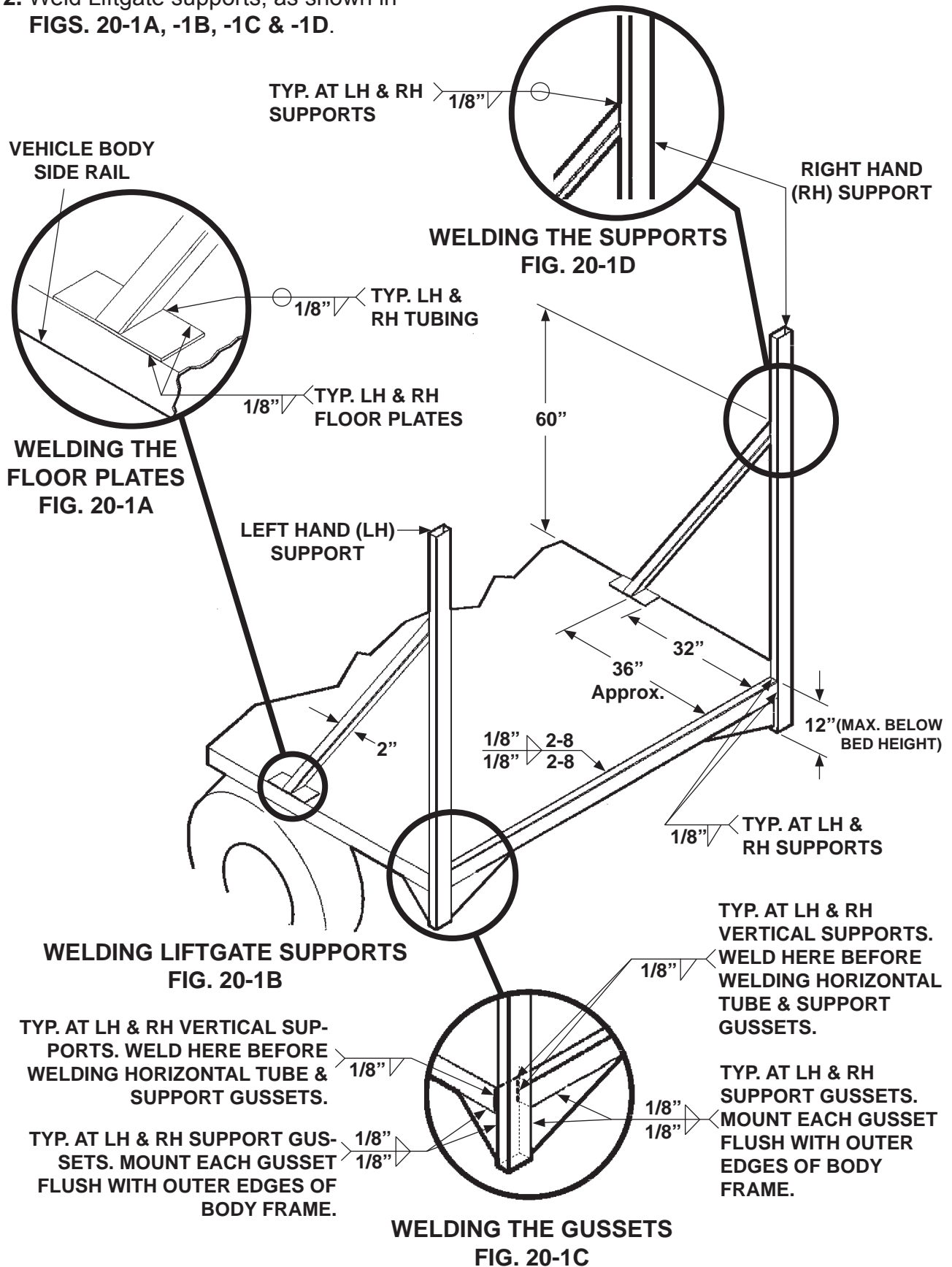

11921 Slauson Ave. Santa Fe Springs, CA. 90670 (800) 227-4116 FAX (888) 771-7713

MAXON

STEP 2 - CHOOSE METHOD OF INSTALLATION

NOTE: MAXON recommends pre-installing the extension plate and mounting plates on the vehicle body before installing the Liftgate.

NOTE: In METHOD 1, the extension plate and mounting plates come separate as part of the bolt-on installation kit.

Three methods for mounting a BMR-CS Liftgate on a vehicle body are covered in this manual.

METHOD 1 - Column mounting plates and extension plate can be welded to vehicle body before bolting on the Liftgate (**FIG. 21-1**). Refer to the **PRE-INSTALL MOUNTING PLATES AND EXTENSION PLATE ON VEHICLE** instructions in **STEP 3**.

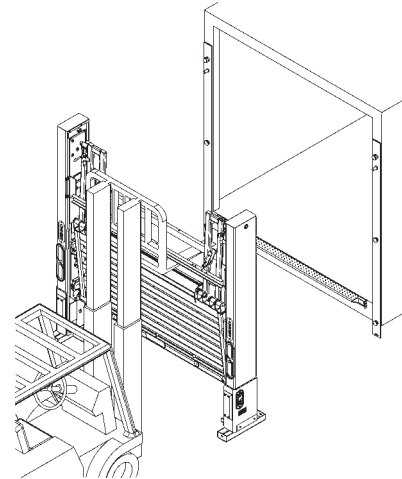

FIG. 21-1

METHOD 2 - Column mounting plates and extension plate are assembled to Liftgate at factory (**FIG. 21-2**). Refer to the **WELD BOLT-ON LIFTGATE TO BODY** instructions in **STEP 3**.

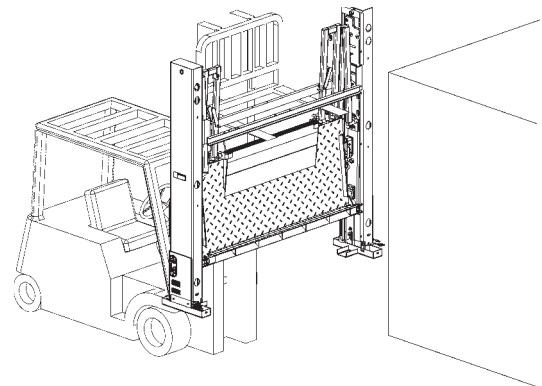

FIG. 21-2

METHOD 3 - Liftgate equipped with extension plate can be welded to vehicle body (**FIG. 21-3**). Refer to the **WELD LIFTGATE TO BODY** instructions in **STEP 3**.

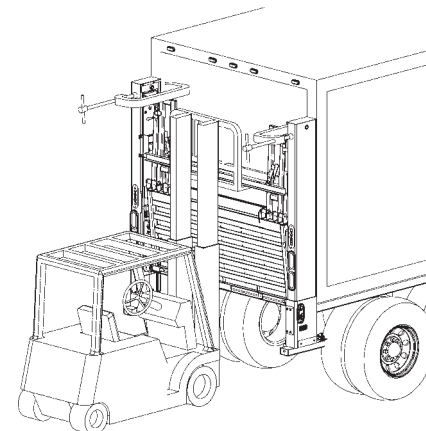

FIG. 21-3

STEP 3 - POSITION LIFTGATE

METHOD 1 - PRE-INSTALL MOUNTING PLATES AND EXTENSION PLATE ON VEHICLE

⚠ WARNING

Recommended practices for welding on steel parts are contained in the current AWS (American Welding Society) D1.1 Structural Welding Code - Steel. Damage to Liftgate and/or vehicle, and personal injury can result from welds that are done incorrectly.

- Center the extension plate on rear of vehicle body and flush with top of the rear sill. Then, weld as shown in **FIGS. 22-1, 22-2 and 22-3.**

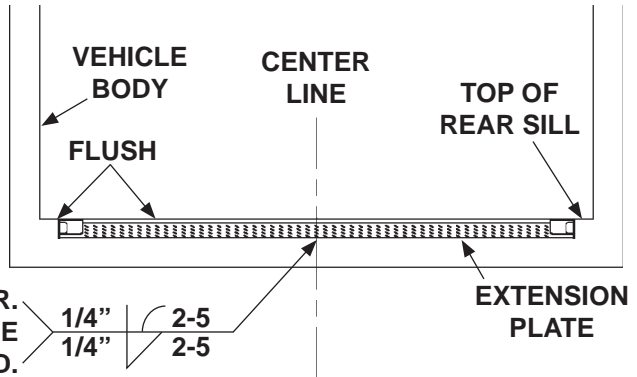

**CENTERING EXTENSION PLATE
ON 96" WIDE VEHICLE BODY
FIG. 22-1**

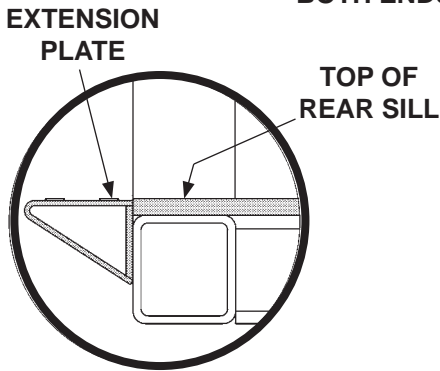

**FLUSH EXTENSION PLATE
FIG. 22-3**

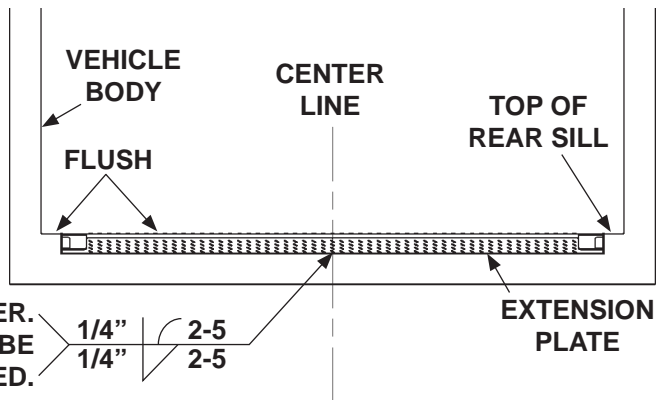

**CENTERING EXTENSION PLATE
ON 102" WIDE VEHICLE BODY
FIG. 22-2**

STEP 3 - POSITION LIFTGATE - Continued

METHOD 1 - PRE-INSTALL MOUNTING PLATES AND EXTENSION PLATE ON VEHICLE - Continued

NOTE: Distance between extension plate and RH mounting plate is measured from the inside edge of mounting plate as shown in illustration.

2. Position RH mounting plate as shown in **FIGS. 23-1 and 23-1A**.

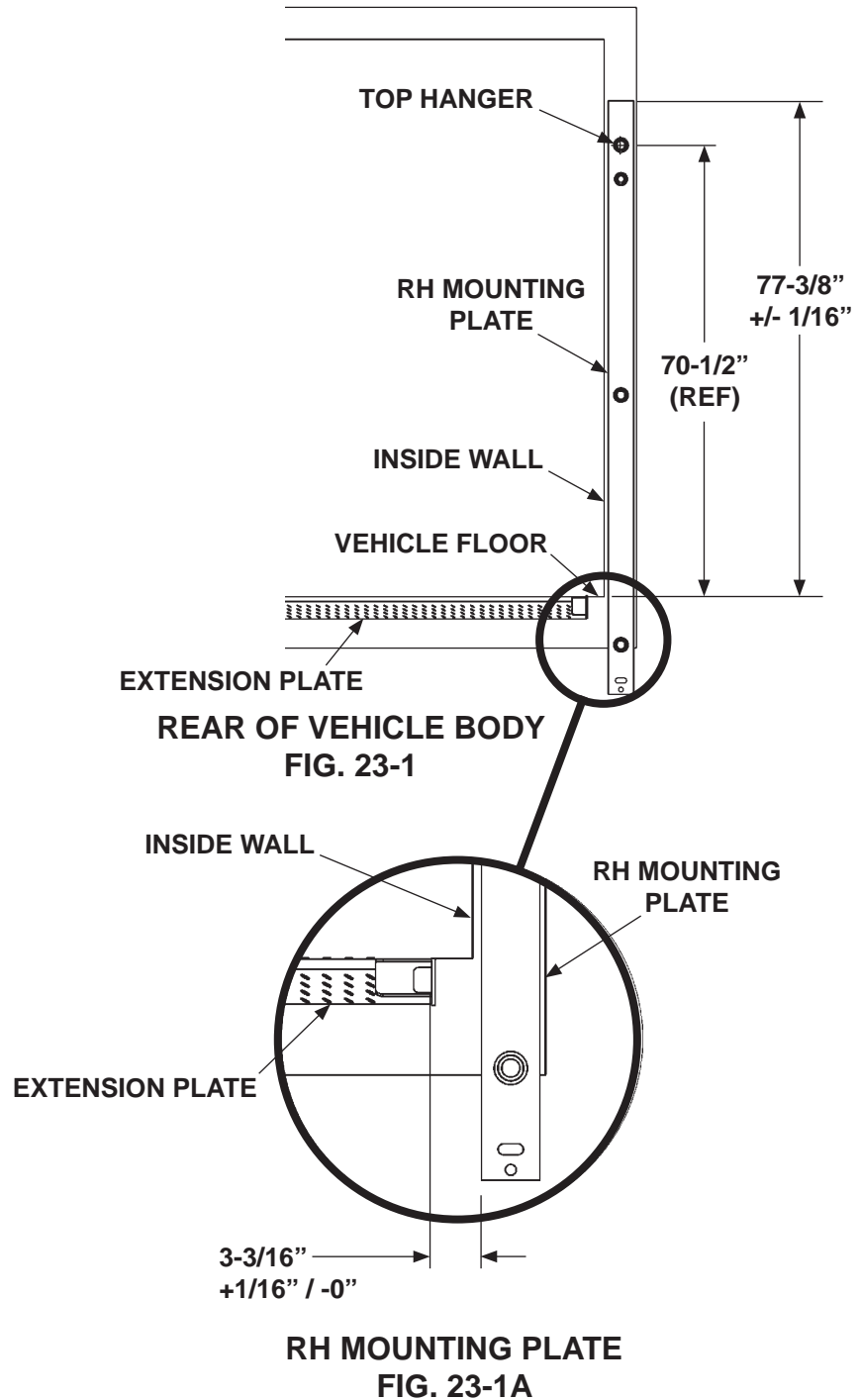

STEP 3 - POSITION LIFTGATE - Continued

METHOD 1 - PRE-INSTALL MOUNTING PLATES AND EXTENSION PLATE ON VEHICLE - Continued

NOTE: Installer can use either set of dimensions shown in **FIG. 24-1** to install RH mounting plate. The first set of dimensions is taken from the center of each hanger, and the second set of dimensions is taken from the inner edge of the mounting plates.

3. Position LH mounting plate on vehicle body as shown in **FIGS. 24-1, 24-1A, and 24-1B.**

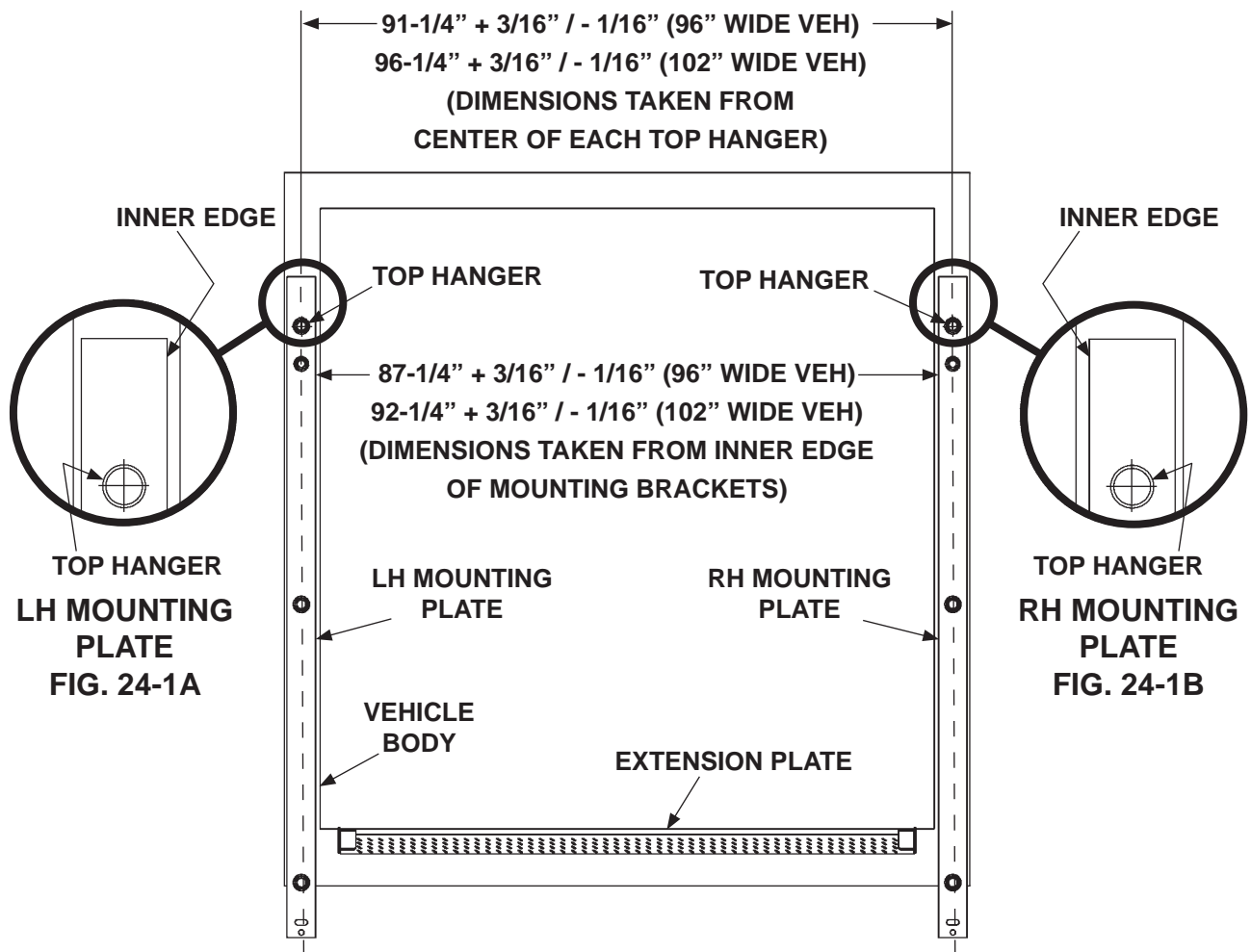

FIG. 24-1

STEP 3 - POSITION LIFTGATE - Continued

METHOD 1 - PRE-INSTALL MOUNTING PLATES AND EXTENSION PLATE ON VEHICLE - Continued

NOTE: Before welding mounting plates to vertical posts on vehicle body, check to make sure LH and RH mounting plates are positioned within dimensions shown in **FIGS. 25-1A** and **25-1B**.

- Place a straight edge across LH and RH mounting plates (**FIG. 25-1**). Ensure that any gap between the mounting plates and straight edge (**FIGS. 25-1A** and **25-1B**) are less than 1/16" maximum.

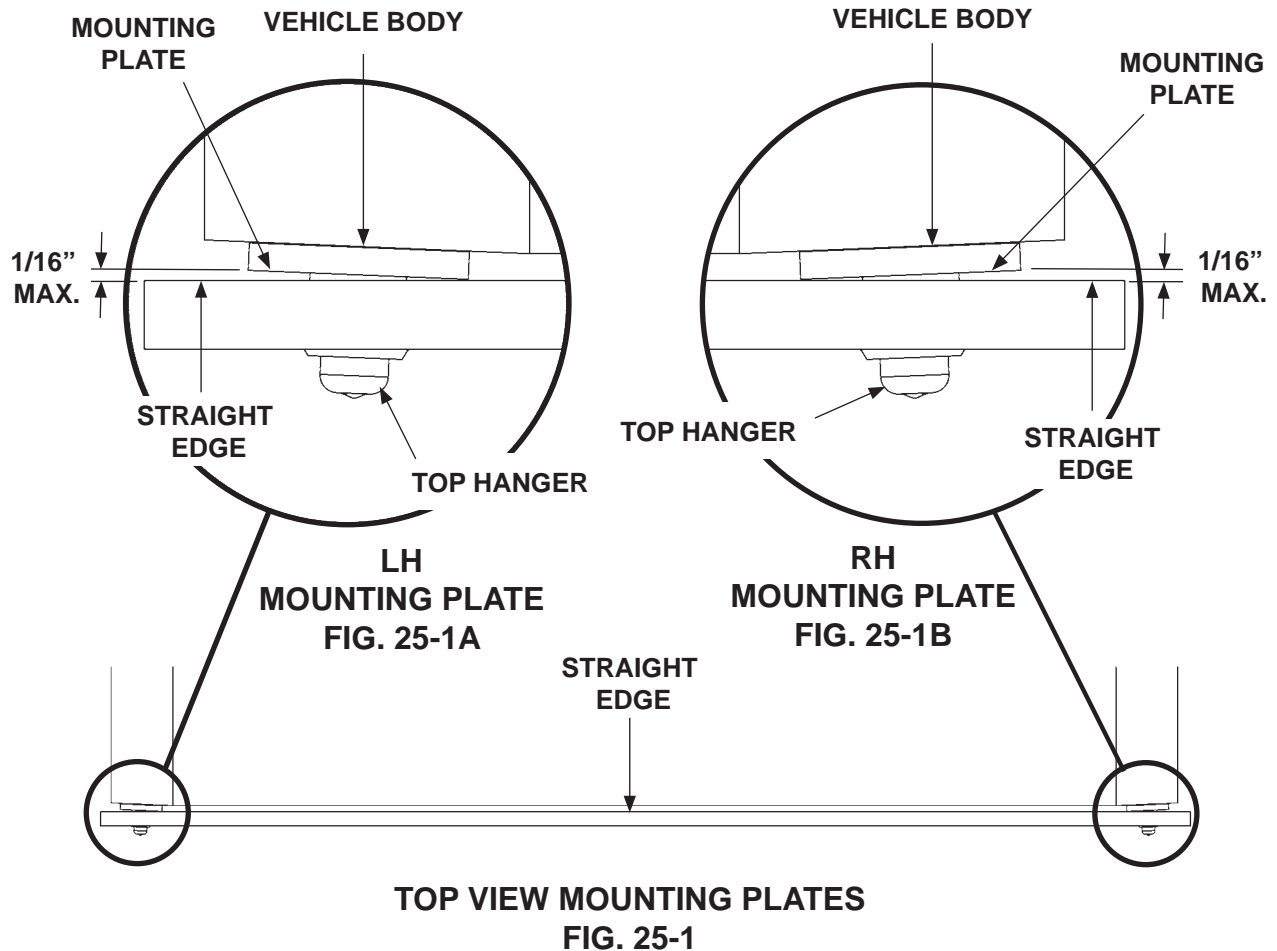

MAXON® 11921 Slauson Ave. Santa Fe Springs, CA. 90670 (800) 227-4116 FAX (888) 771-7713

STEP 3 - POSITION LIFTGATE - Continued

METHOD 1 - PRE-INSTALL MOUNTING PLATES AND EXTENSION PLATE ON VEHICLE - Continued

NOTE: Before welding mounting plates to vehicle frame, check squareness to make sure mounting plates are perpendicular to extension plate.

5. Check to make sure mounting plates are square and perpendicular to the extension plate by measuring dimensions **A** and **B** as shown in **FIG. 26-1**. Squareness is acceptable when dimensions **A** and **B** are within 1/4" of each other.
6. Weld RH mounting plate onto vehicle body (**FIG. 26-1**), then weld LH mounting plate onto vehicle body.

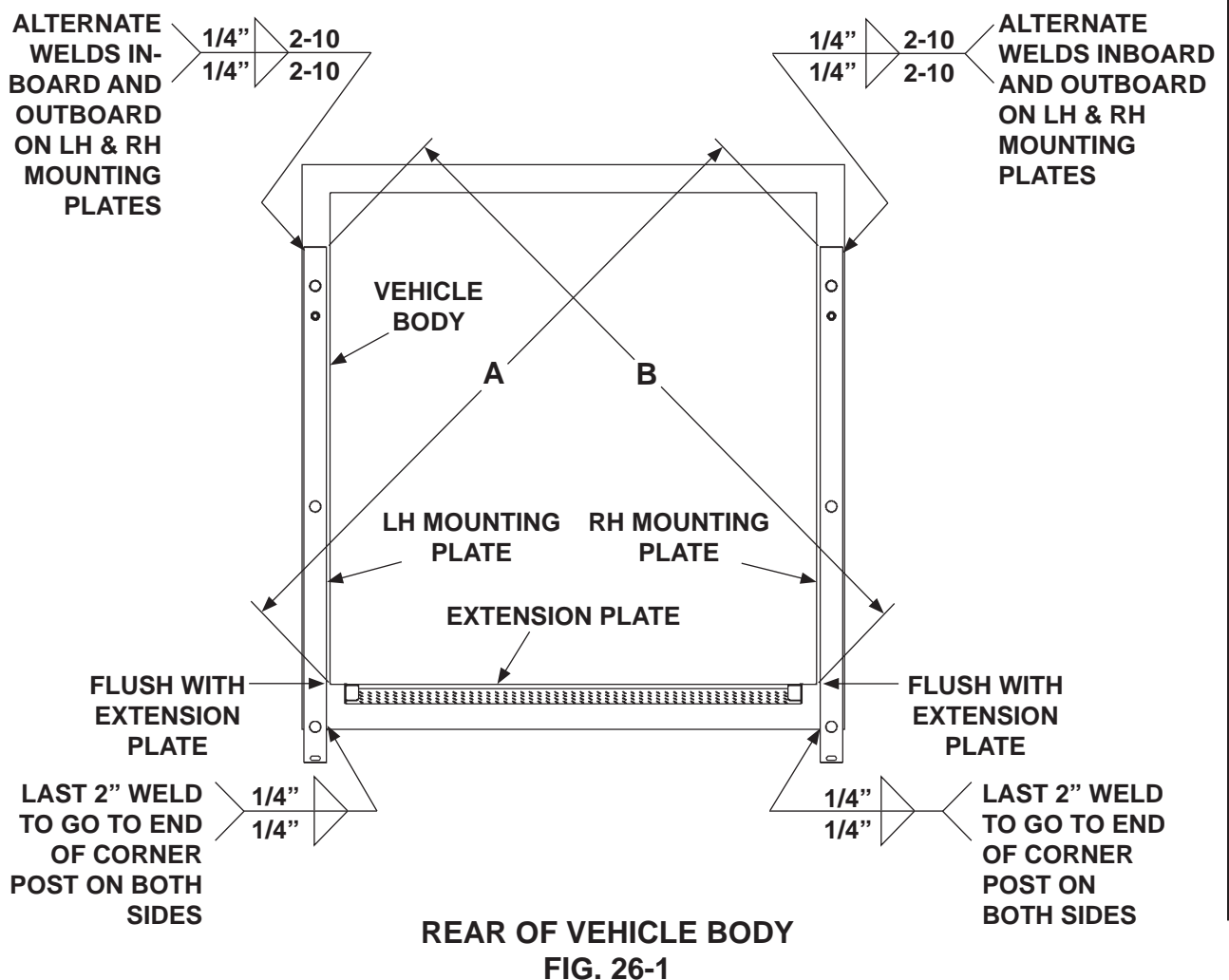

GO TO STEP 4: BOLT LIFTGATE TO VEHICLE

STEP 3 - POSITION LIFTGATE - Continued

METHOD 2 - WELD BOLT-ON LIFTGATE TO BODY

⚠ WARNING

Recommended practices for welding on steel parts are contained in the current AWS (American Welding Society) D1.1 Structural Welding Code - Steel. Damage to Liftgate and/or vehicle, and personal injury, can result from welds that are done incorrectly.

CAUTION

Comply with welding CAUTION decal on the LH column.

1. Weld 2 pieces of 10" X 2" angle stock to the top surface of the extension plate near the RH column as shown in **FIG. 27-1**. Repeat for LH column. The angle stock helps keep extension plate flush with top of vehicle bed while installing Liftgate.

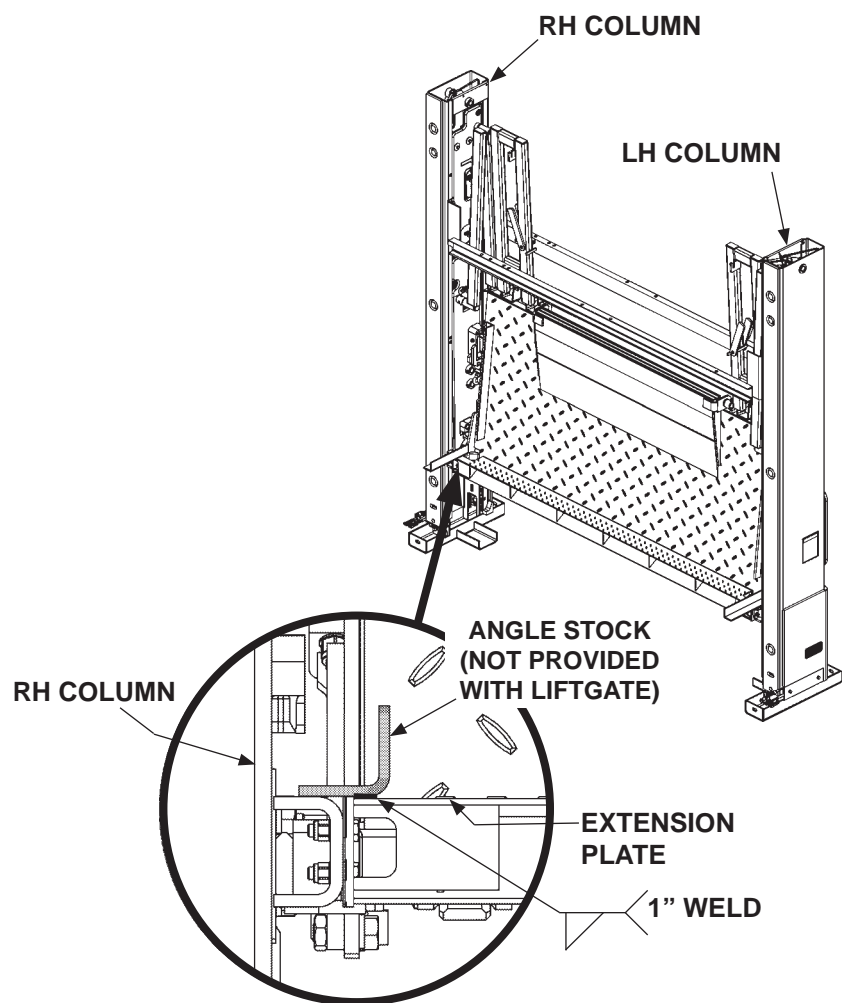

FIG. 27-1

STEP 3 - POSITION LIFTGATE - Continued

METHOD 2 - WELD BOLT-ON LIFTGATE TO BODY - Continued

NOTE: Before welding Liftgate to vehicle frame, check squareness to make sure columns are perpendicular to extension plate.

2. Check to make sure RH and LH columns are square and perpendicular to the extension plate by measuring dimensions at the top and bottom of the columns, and dimensions **A** and **B**, as shown in **FIG. 28-1**. Squareness is acceptable when dimensions **A** and **B** are within 1/4" of each other, and top and bottom column dimensions are as shown in **FIG. 28-1**.

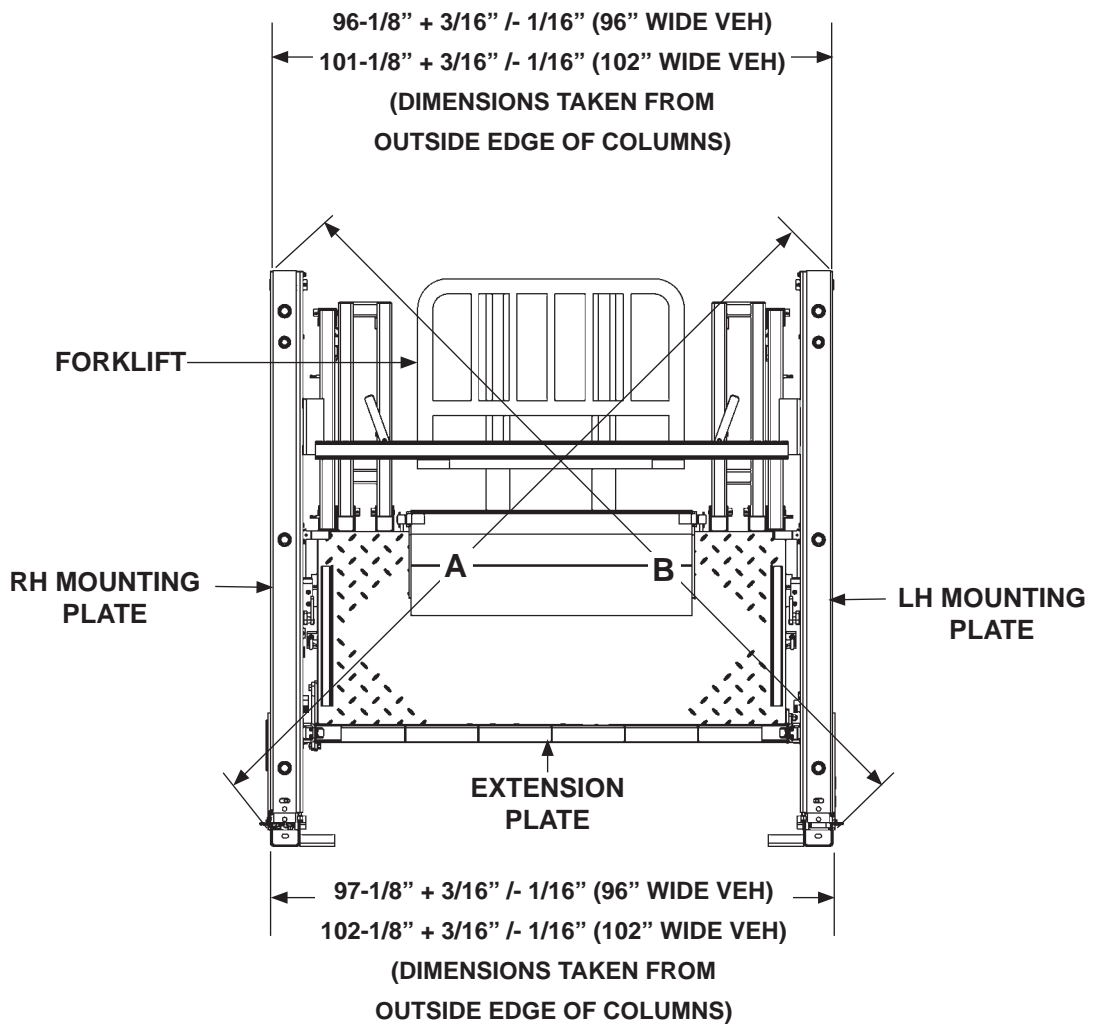

**CHECKING IF COLUMNS ARE SQUARE
(REAR OF LIFTGATE SHOWN)**

FIG. 28-1

STEP 3 - POSITION LIFTGATE - Continued

METHOD 2 - WELD BOLT-ON LIFTGATE TO BODY - Continued

3. Use overhead hoist or fork lift to center Liftgate against the vehicle (**FIG. 29-1**). Let angle stock, welded to extension plate, rest on the top surface of the vehicle bed.
4. Clamp top of each column to vehicle body to prevent gap (**FIG. 29-1**).

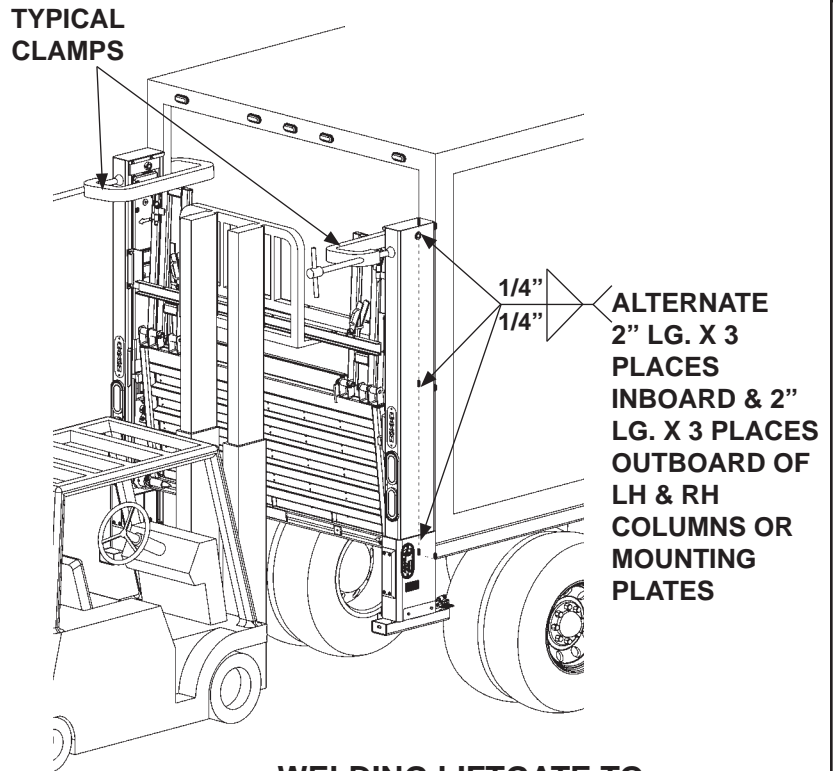

WELDING LIFTGATE TO
VEHICLE
FIG. 29-1

CAUTION

To prevent damage to Liftgate:

- Connect welder ground to vehicle body.
- Protect hydraulic hoses and electrical cables with flame-resistant cover.

5. Weld the RH and LH columns to vehicle body as shown in **FIG. 29-1**.
6. Remove clamp from each of the columns. Then, move fork-lift away from work area.
7. Check to make sure RH and LH columns are square and perpendicular to the extension plate (**FIG. 27-1**).

GO TO STEP 5: REMOVE LOWER SUPPORT FIXTURES

STEP 3 - POSITION LIFTGATE - Continued

METHOD 3 - WELD LIFTGATE TO BODY

⚠ WARNING

Recommended practices for welding on steel parts are contained in the current AWS (American Welding Society) D1.1 Structural Welding Code - Steel. Damage to Liftgate and/or vehicle, and personal injury, can result from welds that are done incorrectly.

NOTE: Before welding extension plate to vehicle body, make sure:

- Inboard edge of extension plate is flush with the top of sill on vehicle body.
- Top surface of extension plate is level with the ground.

CAUTION

Comply with welding CAUTION decal on the LH column.

1. Weld 2 pieces of 10" X 2" angle stock to the top surface of the extension plate near the RH column as shown in **FIG. 30-1**. Repeat for LH column. The angle stock helps keep extension plate flush with top of vehicle bed while installing Liftgate.

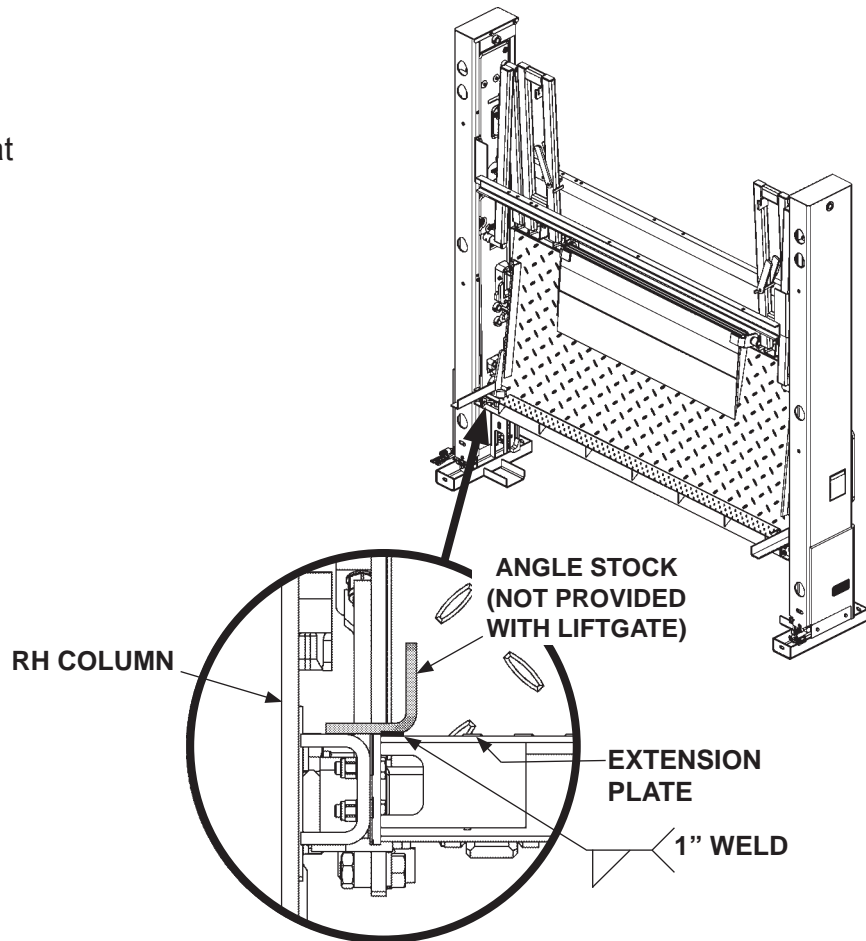

FIG. 30-1

STEP 3 - POSITION LIFTGATE - Continued

METHOD 3 - WELD LIFTGATE TO BODY - Continued

NOTE: Before welding Liftgate to vehicle frame, check squareness to make sure columns are perpendicular to extension plate.

2. Check to make sure RH and LH columns are square and perpendicular to the extension plate by measuring dimensions at the top and bottom of the columns, and dimensions **A** and **B**, as shown in **FIG. 31-1**. Squareness is acceptable when dimensions **A** and **B** are within 1/4" of each other, and top and bottom column dimensions are as shown in **FIG. 31-1**.

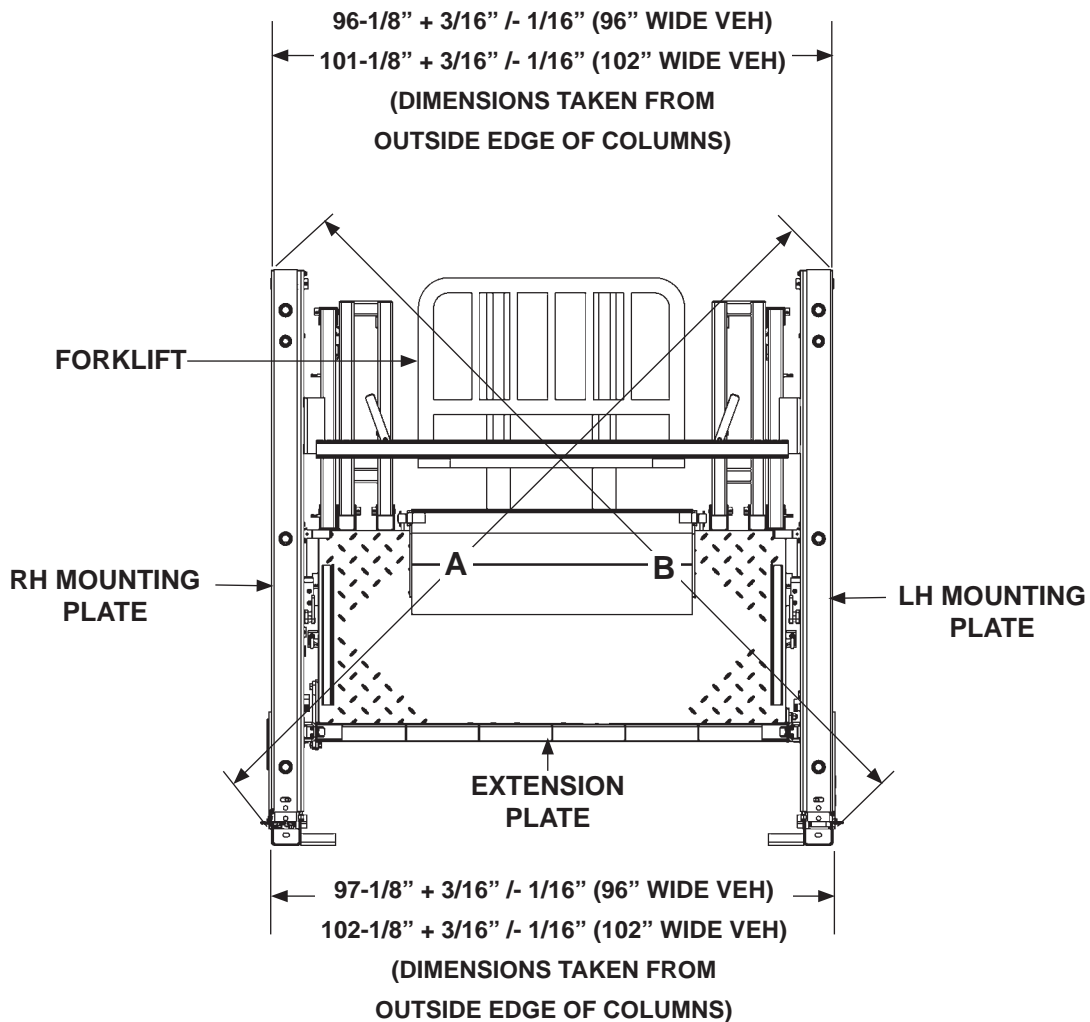

**CHECKING IF COLUMNS ARE SQUARE
(REAR OF LIFTGATE SHOWN)
FIG. 31-1**

STEP 3 - POSITION LIFTGATE - Continued

METHOD 3 - WELD LIFTGATE TO BODY - Continued

3. Use overhead hoist or forklift to center Liftgate against the vehicle (**FIG. 32-1**). Let angle stock, welded to extension plate, rest on the top surface of the vehicle bed.
4. Clamp top of each column to vehicle body to prevent gap (**FIG. 32-1**).

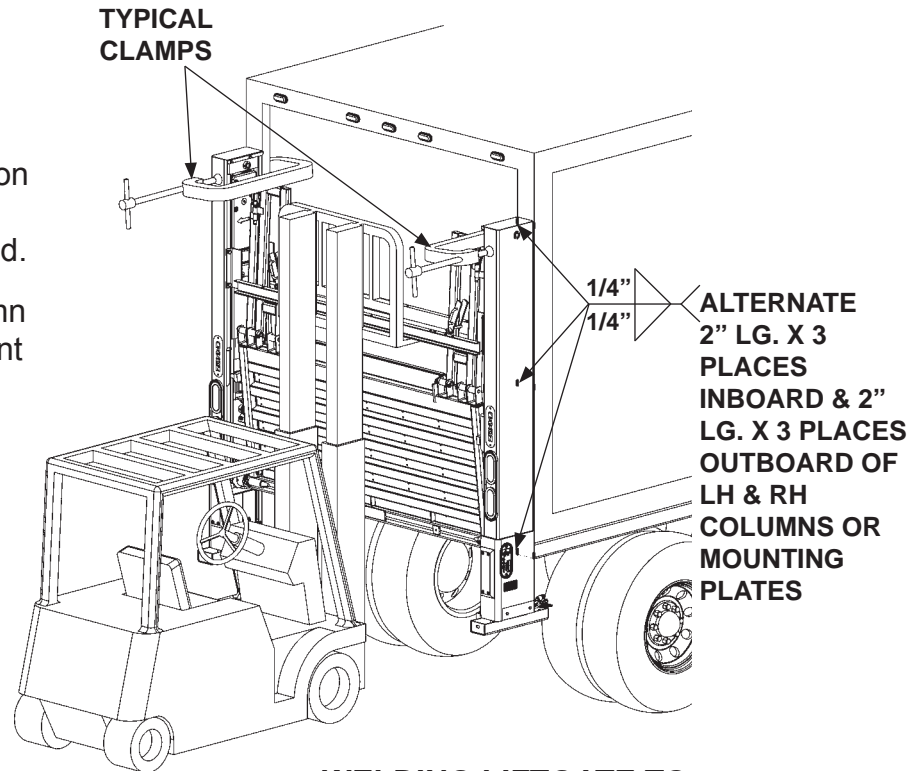

WELDING LIFTGATE TO
VEHICLE
FIG. 32-1

CAUTION

To prevent damage to Liftgate:

- Connect welder ground to vehicle body.
- Protect hydraulic hoses and electrical cables with flame-resistant cover.

5. Weld the RH and LH columns to vehicle body as shown in **FIG. 32-1**.
6. Remove clamp from each of the columns. Then, move forklift away from work area.
7. Check to make sure RH and LH columns are square and perpendicular to the extension plate (**FIG. 30-1**).

GO TO STEP 5: REMOVE LOWER SUPPORT FIXTURES

STEP 4 - BOLT LIFTGATE TO VEHICLE

METHOD 1 - PRE-INSTALLED MOUNTING PLATES & EXTENSION PLATE ON VEHICLE

NOTE: Save all hardware to re-attach column cover and extension plate.

1. Remove screws, lock washers, flat washers and top column cover from LH column (FIGS. 33-1 and 33-1A). Repeat for RH top column cover.
2. Remove (2) cap screws, flat washers, locknuts and spacers from LH column and extension plate (FIGS. 33-1 and 33-1B). Repeat for RH column and extension plate.

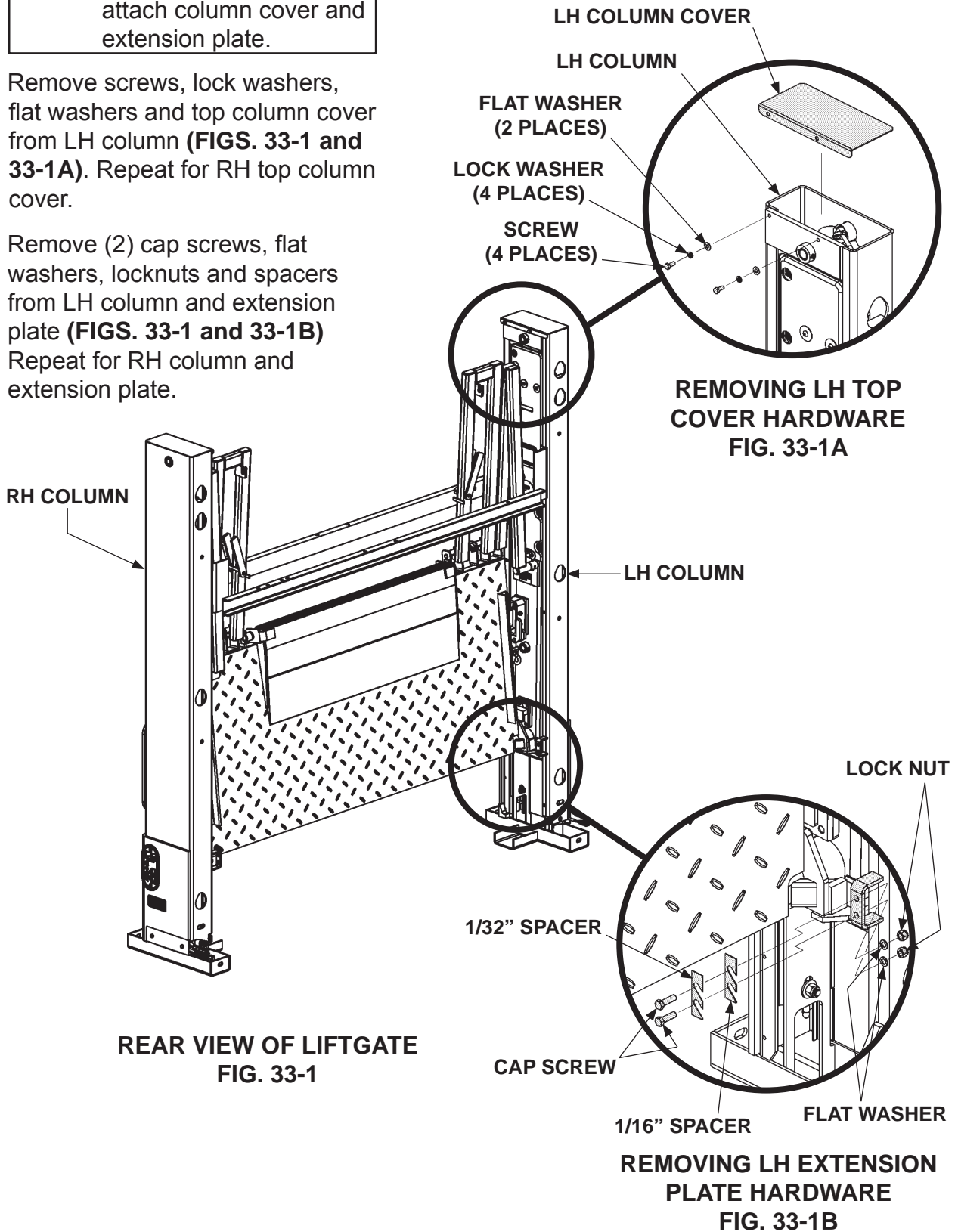

11921 Slauson Ave. Santa Fe Springs, CA. 90670 (800) 227-4116 FAX (888) 771-7713

MAXON

STEP 4 - BOLT LIFTGATE TO VEHICLE - Continued

METHOD 1 - PRE-INSTALLED MOUNTING PLATES & EXTENSION PLATE ON VEHICLE - Continued

NOTE: If the rear of the vehicle & Liftgate mounting plates are galvanized, make sure:

- Bolts are removed from top hanger
- Bolt & cover are removed from hanger lock

3. Check if the Liftgate mounting plates and rear of vehicle are galvanized (**FIG. 34-1**). If galvanized, remove 2 bolts from top hanger on the RH mounting plate (**FIG. 34-1**). Then, remove screw and cover from hanger lock (**FIG. 34-1**). Repeat for LH mounting plate.

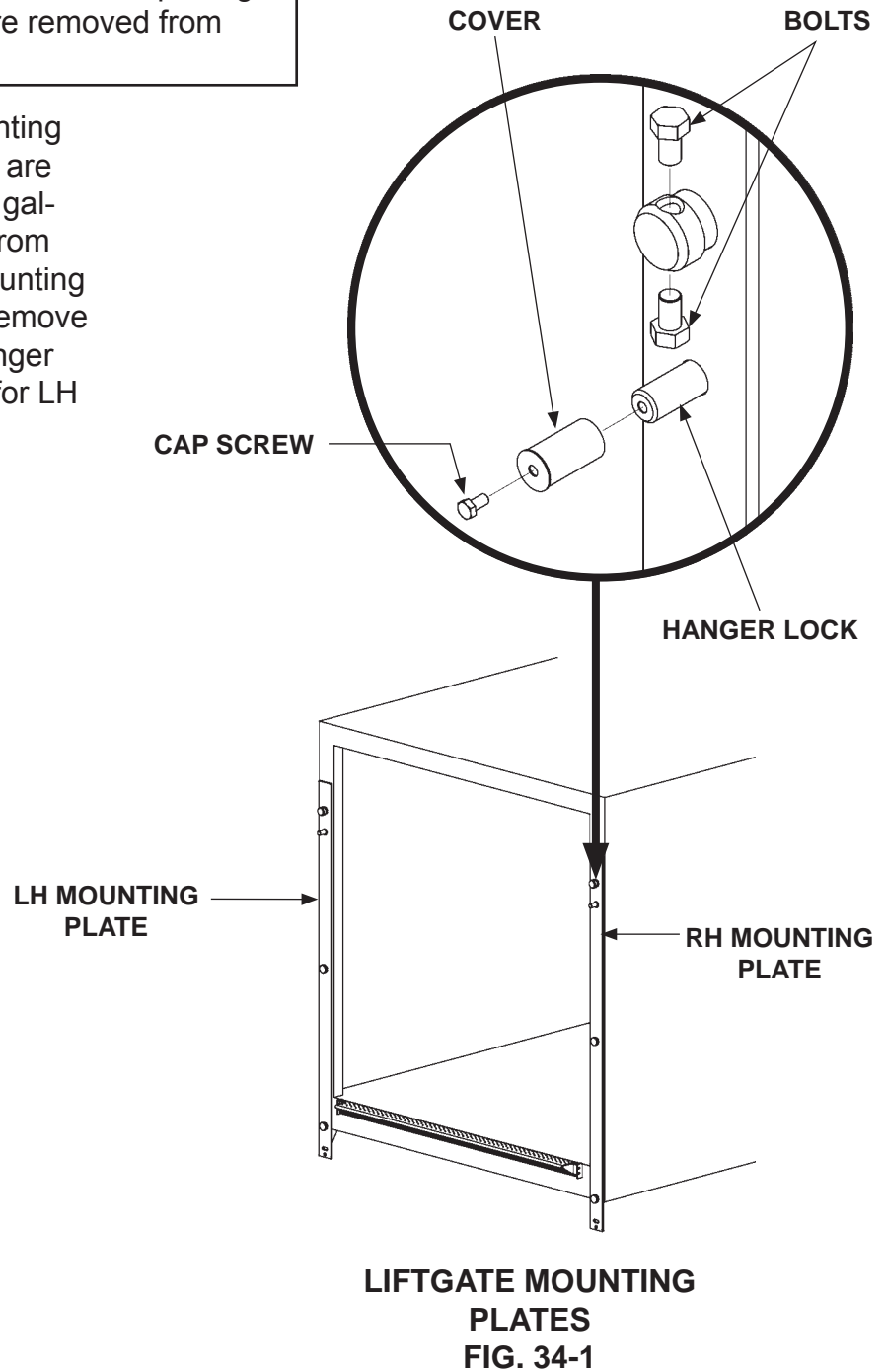

MAXON® 11921 Slauson Ave. Santa Fe Springs, CA. 90670 (800) 227-4116 FAX (888) 771-7713

STEP 4 - BOLT LIFTGATE TO VEHICLE - Continued

METHOD 1 - PRE-INSTALL MOUNTING PLATES AND EXTENSION PLATE ON VEHICLE - Continued

⚠ WARNING

Tighten top hanger bolts on the columns while the Liftgate is supported by forklift. Loose hanger bolts could allow the Liftgate to disengage from the hangers and fall off the vehicle when platform is lowered to the ground. Serious personal injury and equipment damage could result.

4. Hang liftgate on the mounting plates by inserting hangers into hanger slots (FIGS. 35-1 and 35-2).

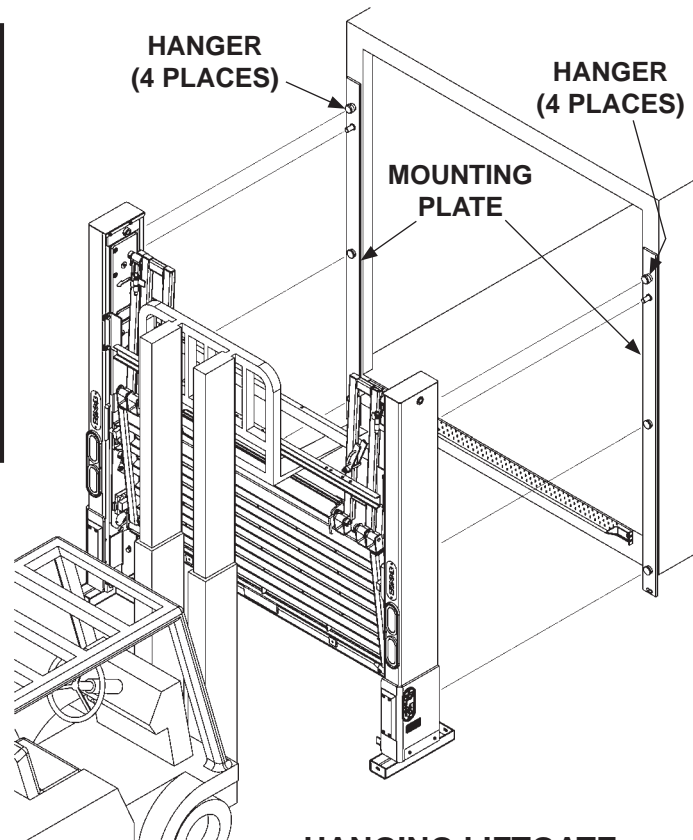

**HANGING LIFTGATE
FIG. 35-1**

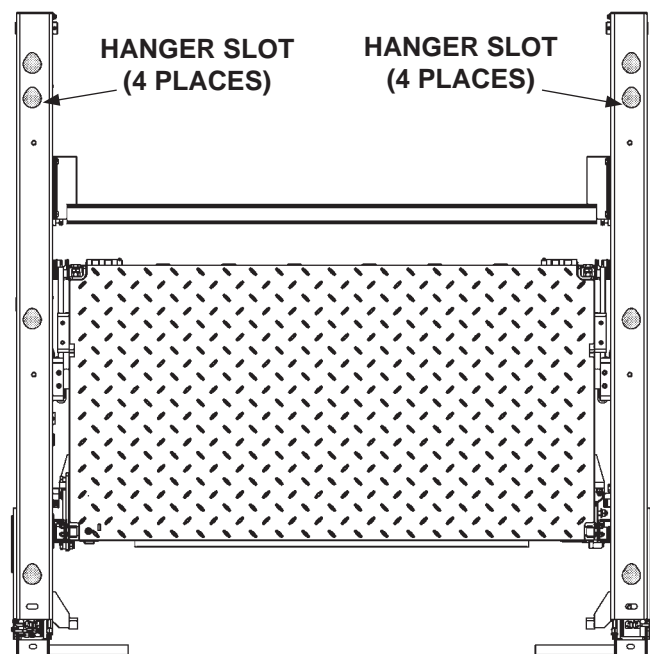

**REAR VIEW OF LIFTGATE
FIG. 35-2**

STEP 4 - BOLT LIFTGATE TO VEHICLE - Continued

METHOD 1 - PRE-INSTALL MOUNTING PLATES AND EXTENSION PLATE ON VEHICLE - Continued

5. Slightly loosen support channel cap screws on the LH column (FIGS. 36-1 and 36-1A) to allow column slots to sit on top hangers and mounting pins (FIG. 36-1B). Repeat for RH column.

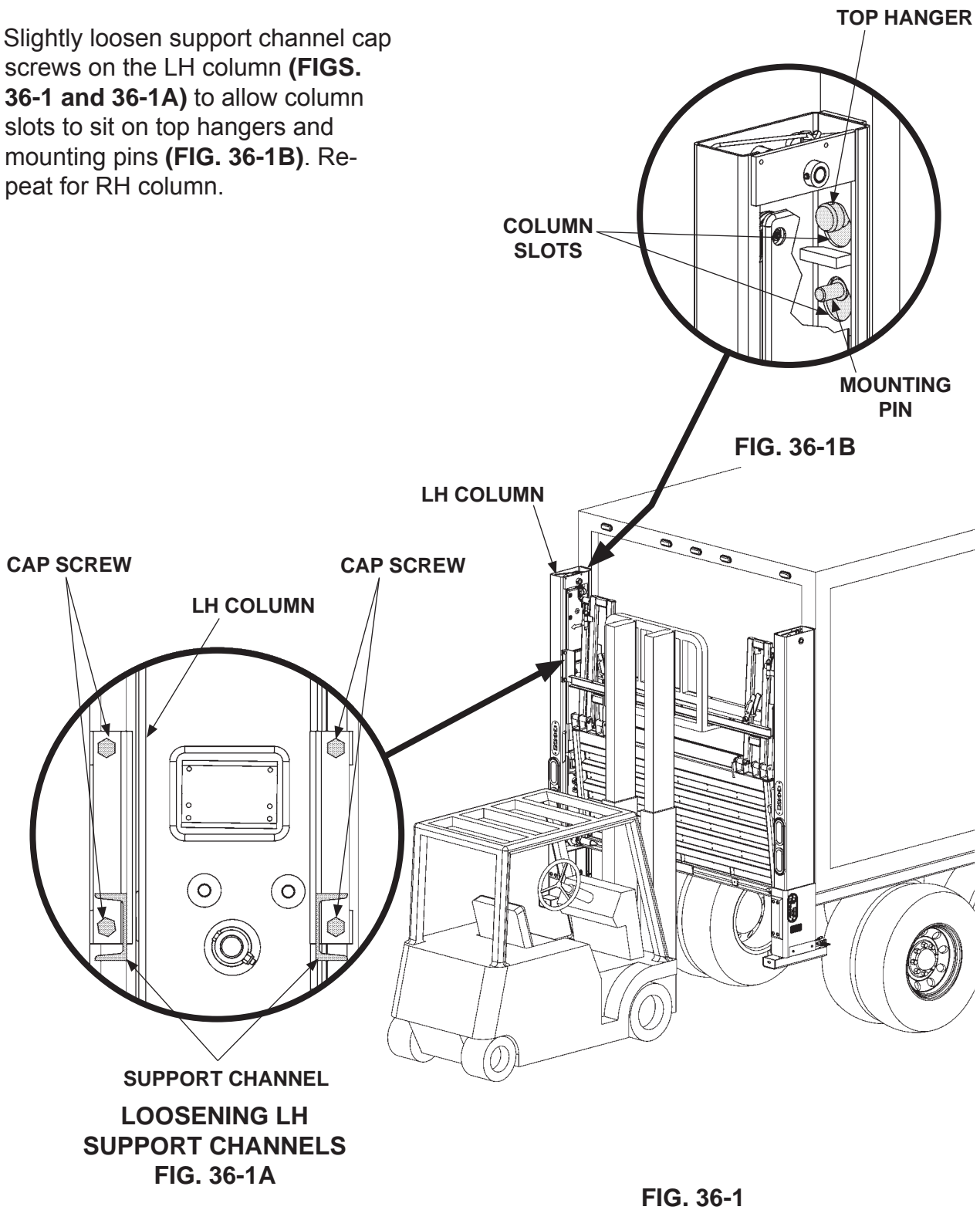

11921 Slauson Ave. Santa Fe Springs, CA. 90670 (800) 227-4116 FAX (888) 771-7713

MAXON

STEP 4 - BOLT LIFTGATE TO VEHICLE - Continued

METHOD 1 - PRE-INSTALL MOUNTING PLATES AND EXTENSION PLATE ON VEHICLE - Continued

6. Get (2) hanger bolts from parts bag. Then look down into the top of LH column (FIGS. 37-1 and 37-1A) and locate top hanger.
7. Insert (1) hanger bolt through top hanger in LH column (FIGS. 37-1 and 37-1B) and tighten against bolt guide until mounting plate is flush with column. Repeat for RH column.
8. Remove forklift.

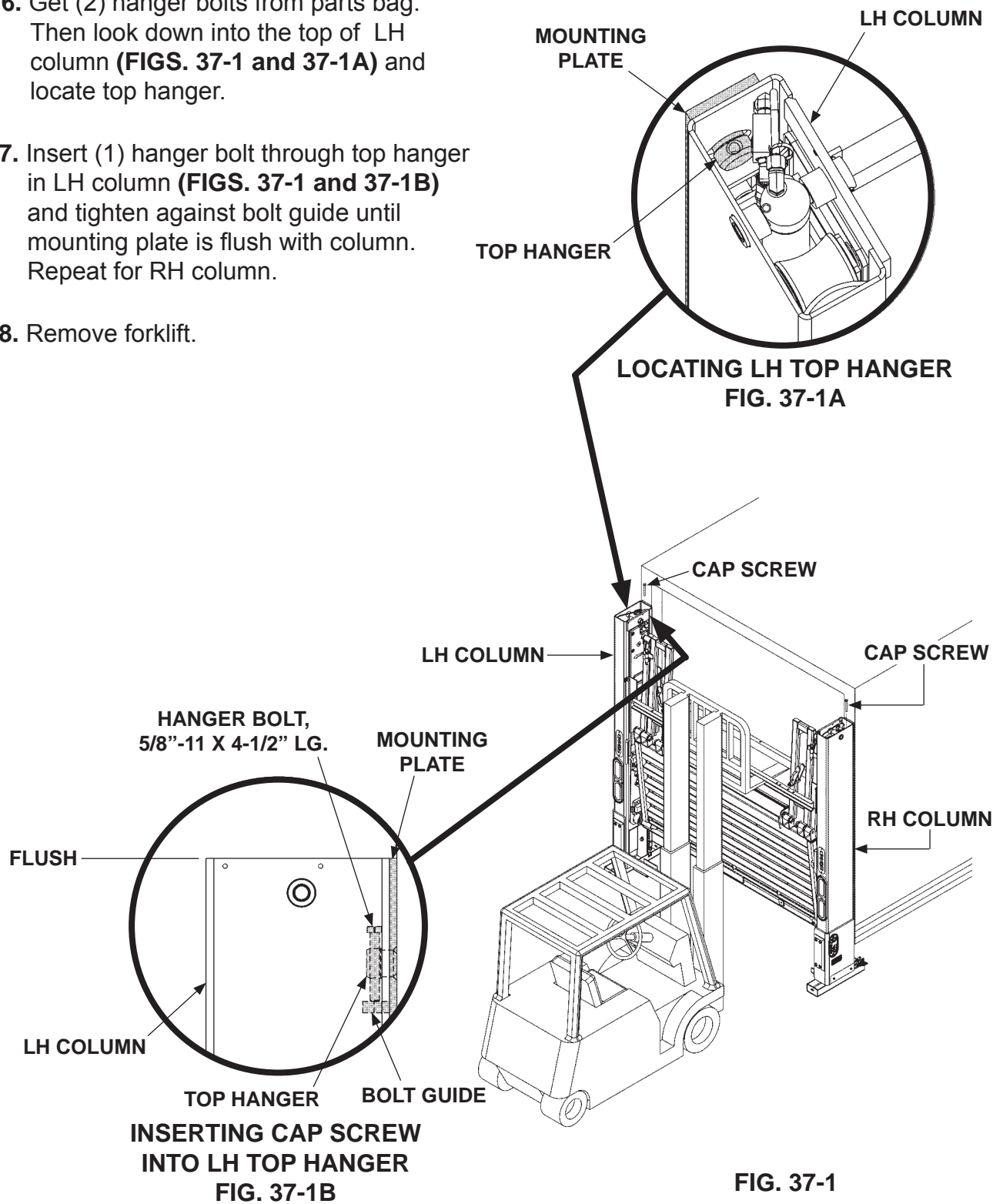
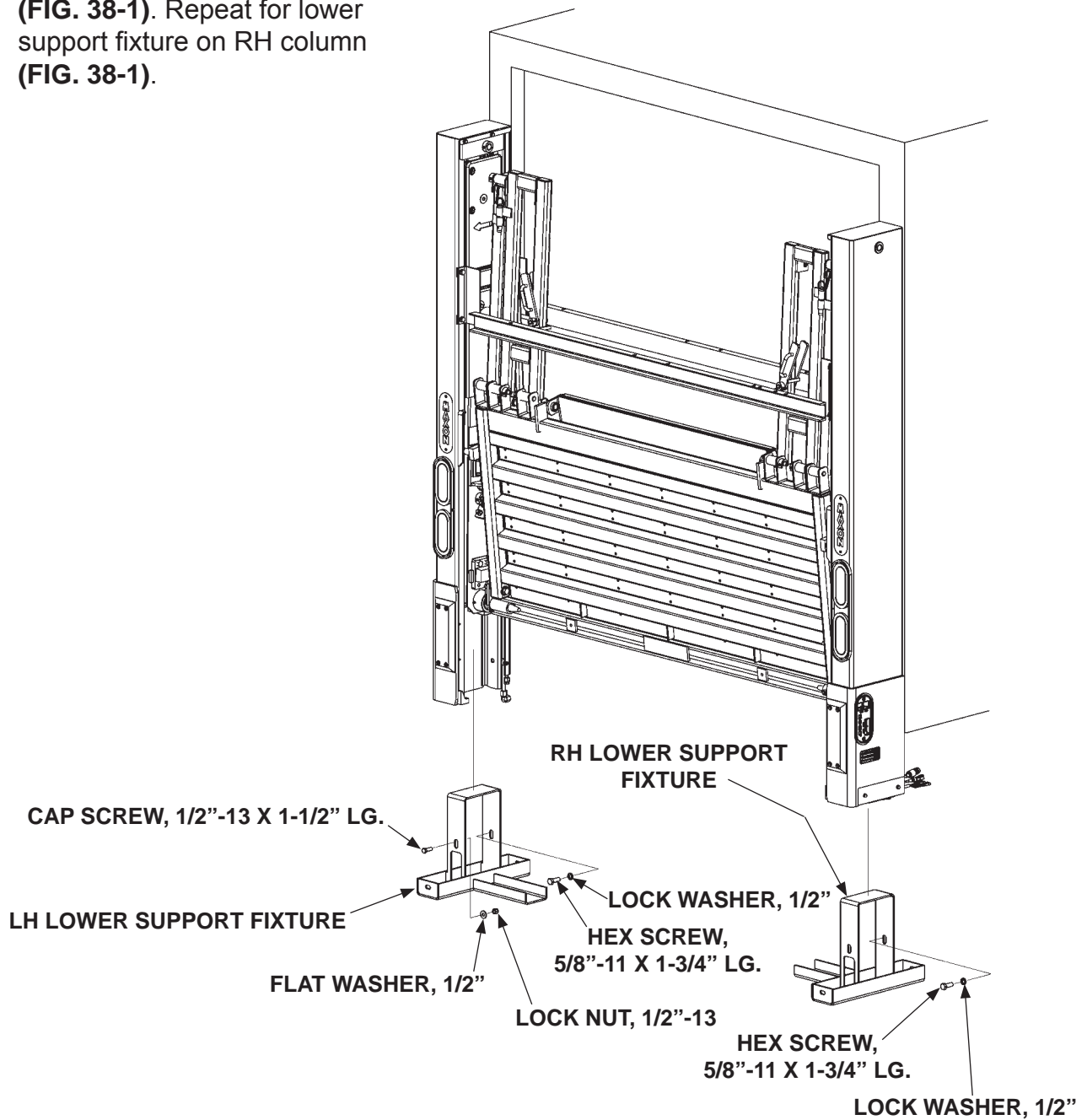

FIG. 37-1

STEP 5 - REMOVE LOWER SUPPORT FIXTURES

NOTE: Use short wrenches for unbolting lower support fixtures.

1. Unbolt and remove lower support fixture from LH column (**FIG. 38-1**). Repeat for lower support fixture on RH column (**FIG. 38-1**).



**REMOVING LOWER SUPPORT FIXTURES
FIG. 38-1**

STEP 6 - POSITION PUMP BOX FRAME

NOTE: Make sure pump box is closer to Liftgate than battery box (if installed) and pump box cover opens toward curb-side of vehicle. Also, make sure hydraulic hoses are installed without straining hoses. Distance from pump box to Liftgate is limited by lengths of hydraulic hoses and wiring harness supplied with Liftgate.

Position pump box frame (or optional battery box) on the ground where it will be welded to vehicle body in the next step. Make sure pump box (and battery box if supplied) are securely bolted to the frame. Typical installations are shown in **FIGS. 39-1, 39-2, 40-1, 40-2 and 40-3.**

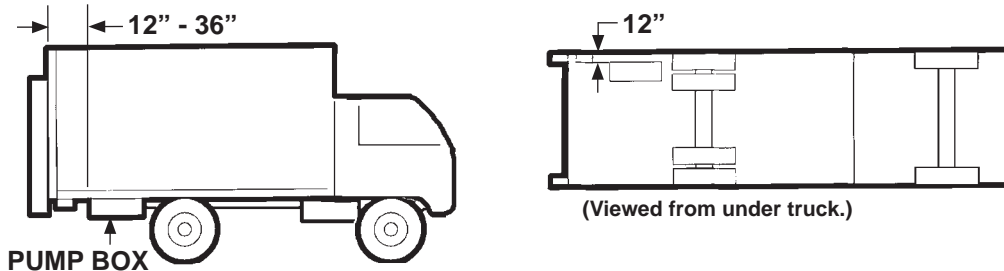

**TYPICAL 3 FT. INSTALLATION
FIG. 39-1**

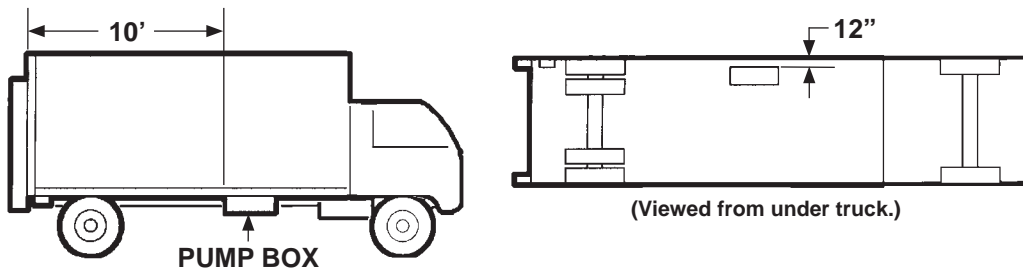

**TYPICAL 10 FT. INSTALLATION
FIG. 39-2**

STEP 6 - POSITION PUMP BOX FRAME - Continued

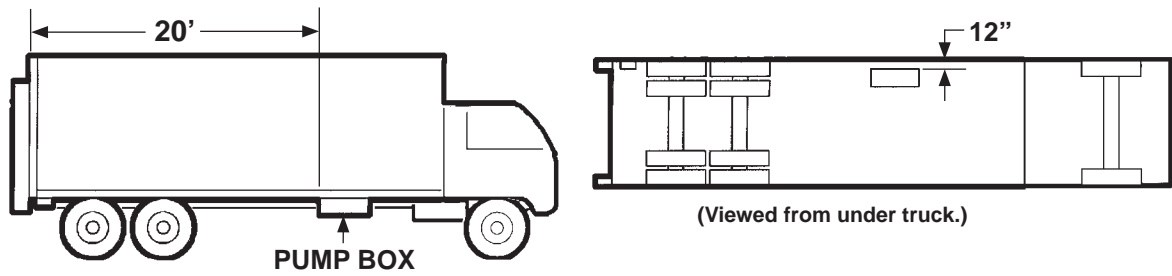

TYPICAL 20 FT. INSTALLATION

FIG. 40-1

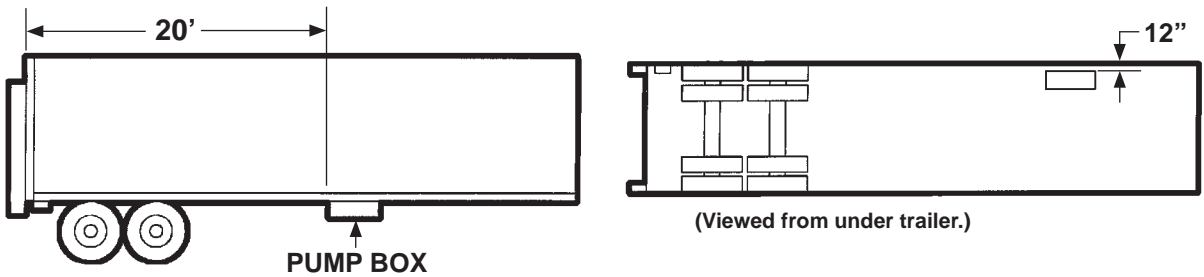

TYPICAL 20 FT. INSTALLATION

FIG. 40-2

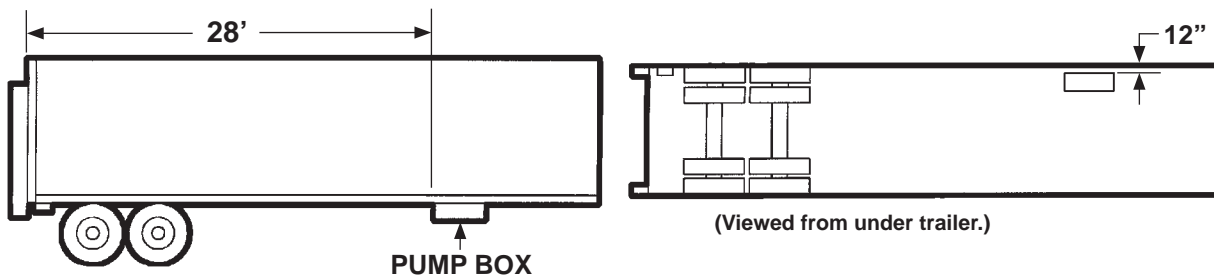

TYPICAL 28 FT. INSTALLATION

FIG. 40-3

STEP 7 - ATTACH PUMP & BATTERY BOX FRAME TO VEHICLE

NOTE: There are 2 methods to mount pump and battery box frame to vehicle frame.

- Bolt pump and battery box frame to hanger brackets welded to vehicle frame.
- Weld pump and battery box frame to vehicle frame.

1. Use floor jack or equivalent lifting device to place pump and battery box frame in position on vehicle body cross members as shown in **FIG. 41-1**.

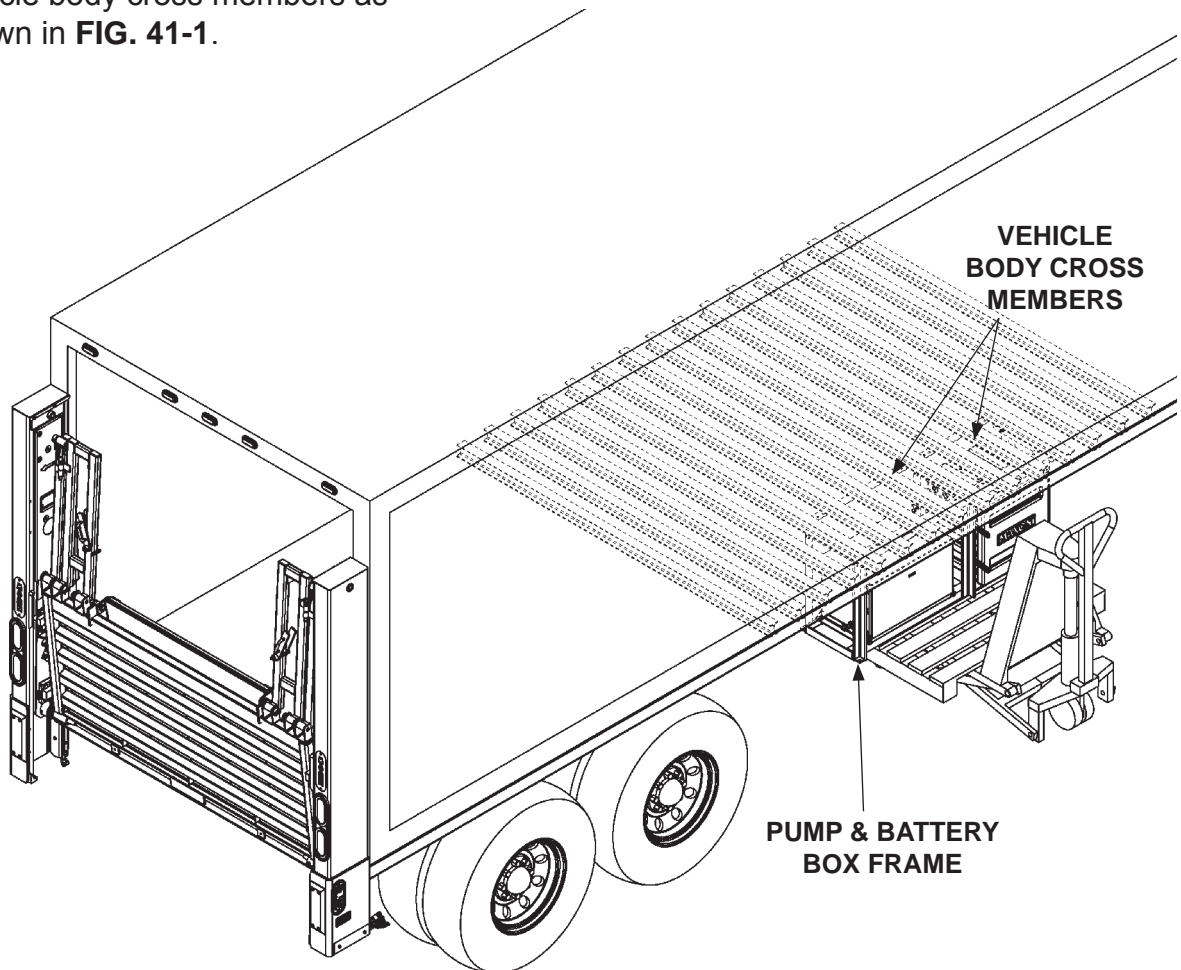

TRAILER WITH PUMP & BATTERY BOX FRAME
FIG. 41-1

NOTE: If pump and battery box frame is to be welded directly to cross members on vehicle body, skip **instructions 2 through 4**. Continue with **instruction 5**.

STEP 7 - ATTACH PUMP & BATTERY BOX FRAME TO VEHICLE - Continued

NOTE: Do instructions 3 through 5 if hanger brackets are being used to mount pump and battery box frame on vehicle.

2. Select holes on top of battery box frame to align mounting brackets flush to cross members. Refer to **FIGS. 42-1 & 42-1A** for trailers and **FIG. 42-2** for trucks. Bolt mounting brackets to battery box frame as shown in **FIG. 42-1B**. Torque each bolt and lock nut to **85-128 lb-ft.**

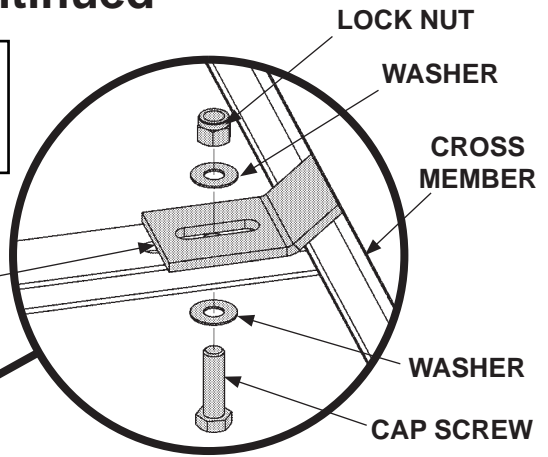

**BOLTING BRACKETS
(8 PLACES)
FIG. 42-1B**

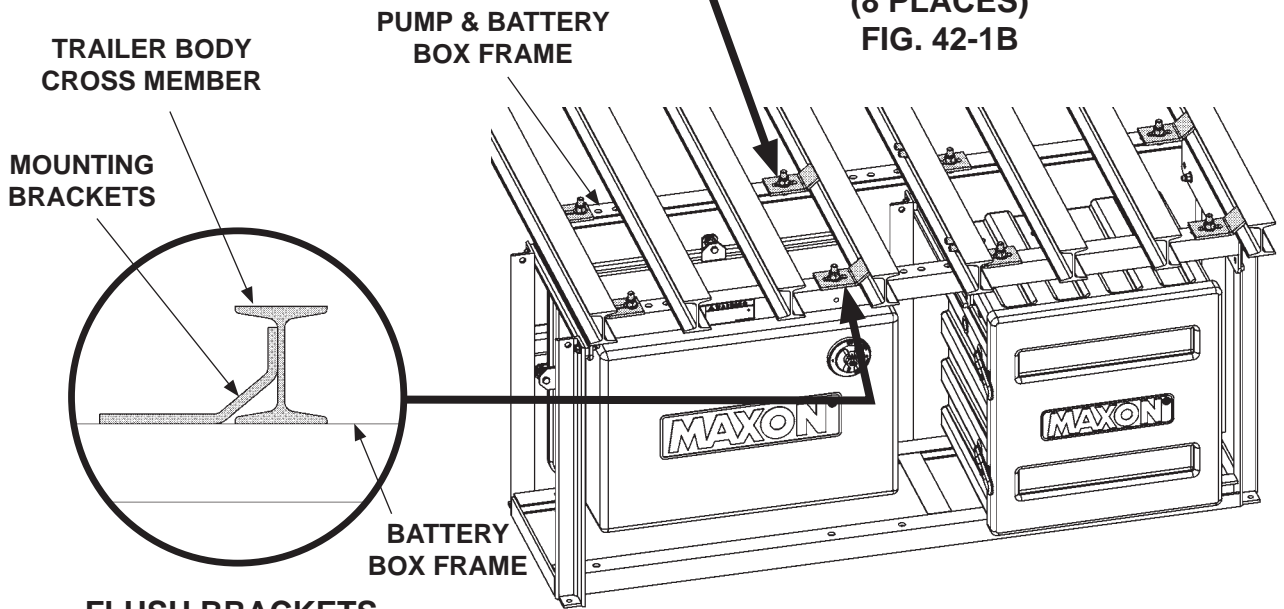

**ALIGNING PUMP & BATTERY
BOX FRAME
FIG. 42-1**

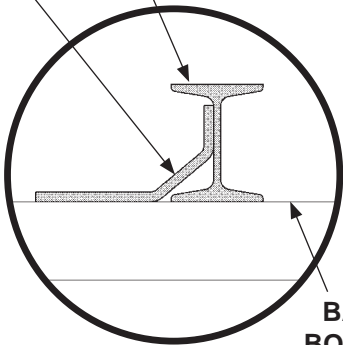

**FLUSH BRACKETS
FOR TRAILERS
(8 PLACES)
FIG. 42-1A**

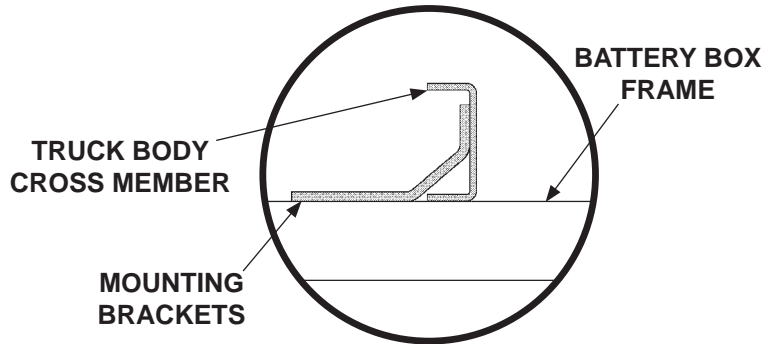

**FLUSH BRACKETS FOR TRUCKS
(8 PLACES)
FIG. 42-2**

11921 Slauson Ave. Santa Fe Springs, CA. 90670 (800) 227-4116 FAX (888) 771-7713
MAXON

STEP 7 - ATTACH PUMP & BATTERY BOX FRAME TO VEHICLE - Continued

NOTE: If welding mounting brackets to cross members, skip instruction 3.

- Using mounting brackets as a template mark and drill holes through cross members (FIG. 43-1). Bolt mounting brackets to cross members as shown in FIGS. 43-2 and 43-2A. Torque bolts and lock nuts to 85-128 lb-ft.

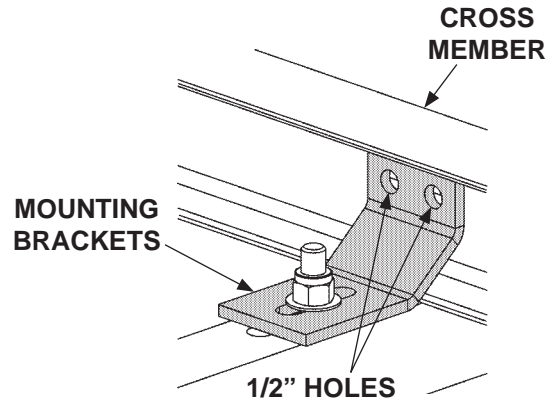

MARK AND DRILL
FIG. 43-1

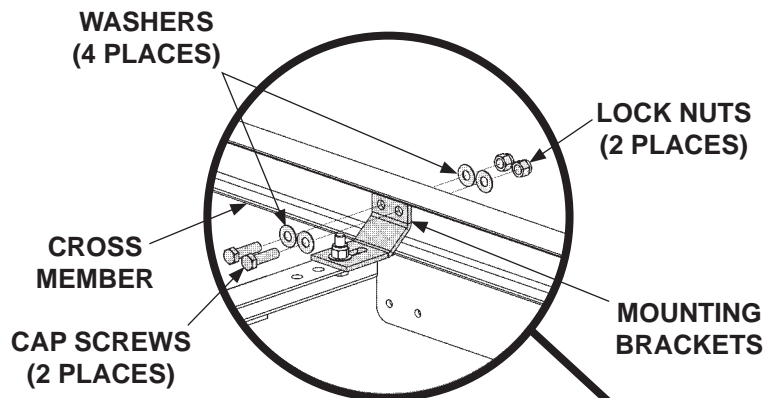

BOLTING BRACKETS
(8 PLACES)
FIG. 43-2A

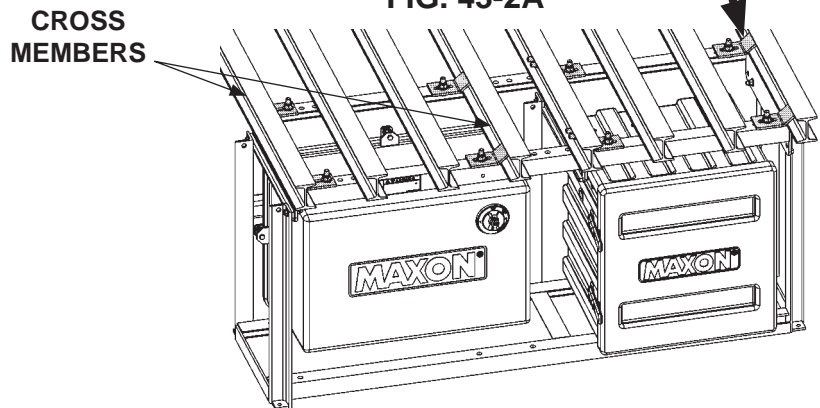

BOLTING PUMP & BATTERY
BOX FRAME
FIG. 43-2

STEP 7 - ATTACH PUMP & BATTERY BOX FRAME TO VEHICLE - Continued

⚠ WARNING

Recommended practices for welding on steel parts are contained in the current AWS (American Welding Society) D1.1 Structural Welding Code - Steel. Damage to Liftgate and/or vehicle, and personal injury can result from welds that are done incorrectly.

CAUTION

To prevent pump box components from being damaged by electric current from welding, connect welder grounding cable to the part being welded.

CAUTION

Cover pump box and optional battery box with flame-resistant covering before welding pump box frame to vehicle.

4. Weld each bracket to cross members as shown in **FIGS. 44-1 and 44-1A**. Weld top of bracket if accessible.

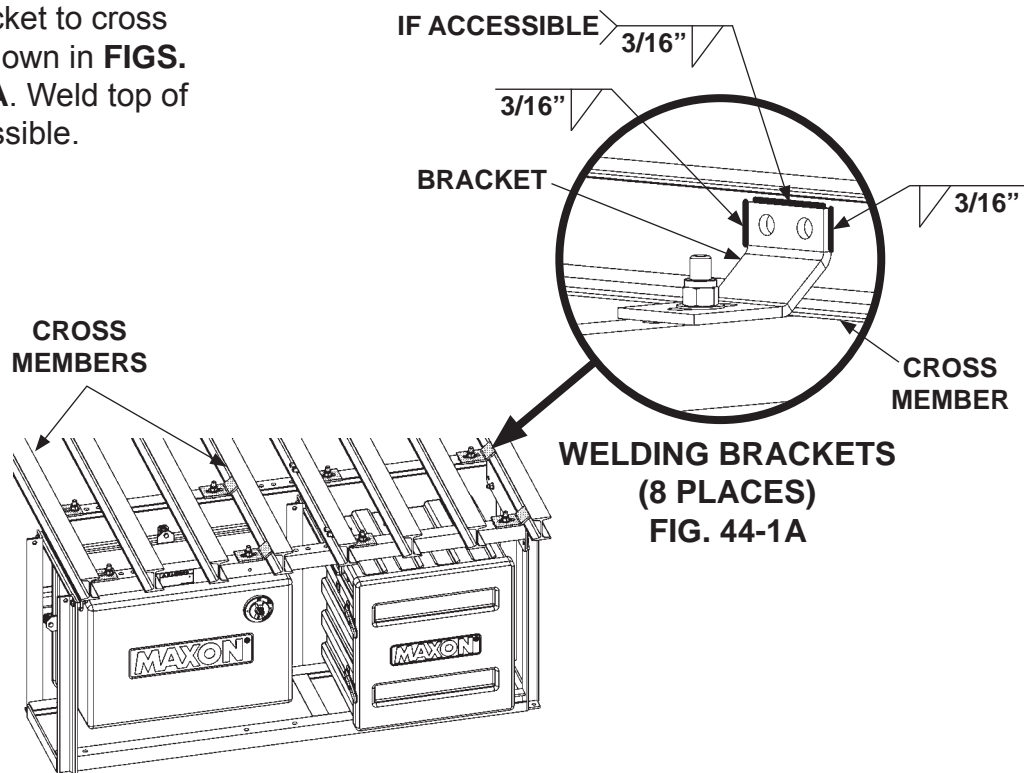

WELDING PUMP & BATTERY BOX FRAME
FIG. 44-1

GO TO THE END OF STEP 5 & OBSERVE THE WARNING ABOUT HYDROGEN GAS BUILD-UP. THEN GO TO STEP 6.

STEP 7 - ATTACH PUMP & BATTERY BOX FRAME TO VEHICLE - Continued

⚠ WARNING

Explosive hydrogen gas from charging batteries can accumulate in battery box if not vented from the box. To prevent hydrogen gas from accumulating, ensure the 3 ventilation holes in battery box are not plugged or covered.

NOTE: Any methods not shown in this section, for welding mounting brackets to cross members, must be approved by body or trailer manufacturer.

5. Position pump and battery box frame on vehicle frame cross members (**FIG. 45-1**). Ensure vent holes on back of the battery box are not obstructed or covered (**FIG. 45-1**). Weld pump and battery box frame to cross members as shown in **FIG. 45-1**.

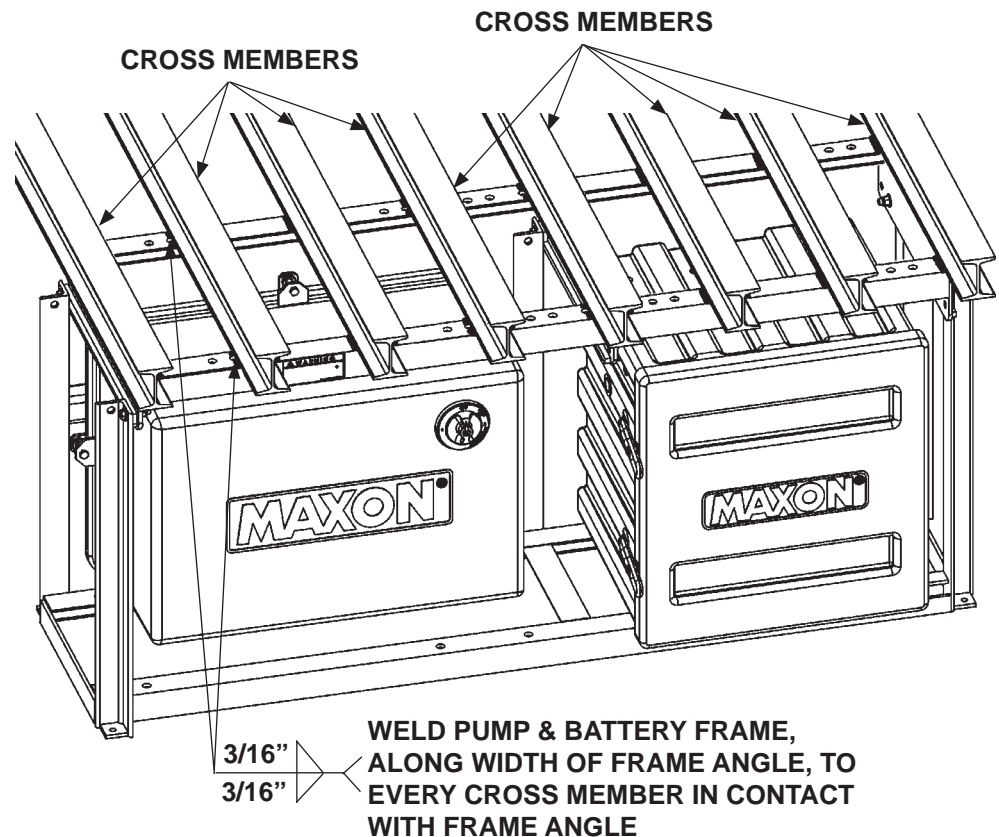

ALIGNING PUMP & BATTERY BOX FRAME TO WELD ON CROSS MEMBERS
FIG. 45-1

STEP 7 - ATTACH PUMP & BATTERY BOX FRAME TO VEHICLE - Continued

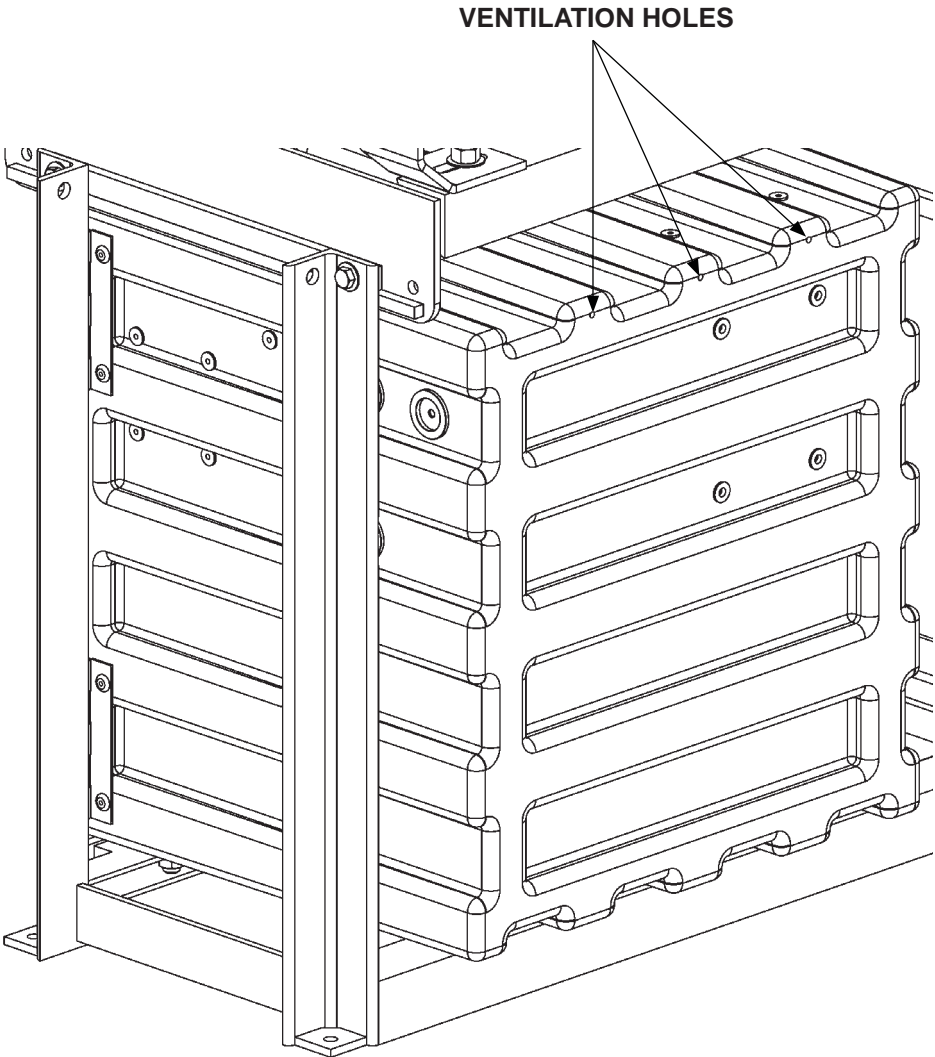

**BATTERY BOX ASSEMBLY
(REAR VIEW SHOWN)
FIG. 46-1**

MAXON[®] 11921 Slauson Ave. Santa Fe Springs, CA. 90670 (800) 227-4116 FAX (888) 771-7713

STEP 8 - RUN HYDRAULIC LINES & ELECTRIC CABLES

⚠ CAUTION

Always route hydraulic hoses and electrical wiring clear of moving parts, brake lines, sharp edges and exhaust systems. Avoid making sharp bends in hoses and wiring. Make sure that bends in the electrical wiring are 1" or more away from electrical connector. Attach securely. If drilling is necessary, first check behind the drilling surface so you do not damage any fuel lines, vent lines, brake lines or wires.

NOTE: The hydraulic cylinders in the Liftgate are filled with hydraulic fluid and bled at the factory. To keep air out of the hydraulic system, follow instructions carefully for installing hydraulic system components.

NOTE: The fold and unfold hydraulic hoses are identical hoses. To avoid confusion when running hoses through the channel, MAXON recommends tapping both ends of one of the hoses for easy identification.

1. Get hydraulic hoses, hydraulic tee, channel guard (if required) and plastic ties from parts box and pump box installation kit. Run hydraulic hoses from LH and RH columns to pump box. Connect hydraulic hoses as shown in **FIG. 48-1** and **TABLES 49-1 and 49-2** for Gravity Down Liftgate or **FIG. 51-1** and **TABLES 52-1 and 52-2** for Power Down Liftgate.
2. Get interconnect harness from pump box installation kit. Run the interconnect harness from pump box to RH and LH columns as shown in **FIG. 53-1**.
3. If channel guard is required, bolt up one side of the channel (**FIGS. 48-1, 51-1 and 52-1**) to vehicle body. Leave bolts loose until all hydraulic hoses (**FIGS. 48-1 and 51-1**) and wiring harness (**FIG. 53-1**) are run through channel. After hoses and wiring harness are run, bolt up second side of channel and tighten all bolts and nuts. Use plastic ties to secure runs of hydraulic hoses and wiring harness that are outside of channel guard.

STEP 8 - RUN HYDRAULIC LINES & ELECTRIC CABLES - Continued

RUN GRAVITY DOWN HYDRAULIC LINES

NOTE: See TABLES 49-1 & 49-2 for information on the numbered hoses in this illustration.

CAUTION
Before connecting hoses, ensure face seal o-rings are in place.

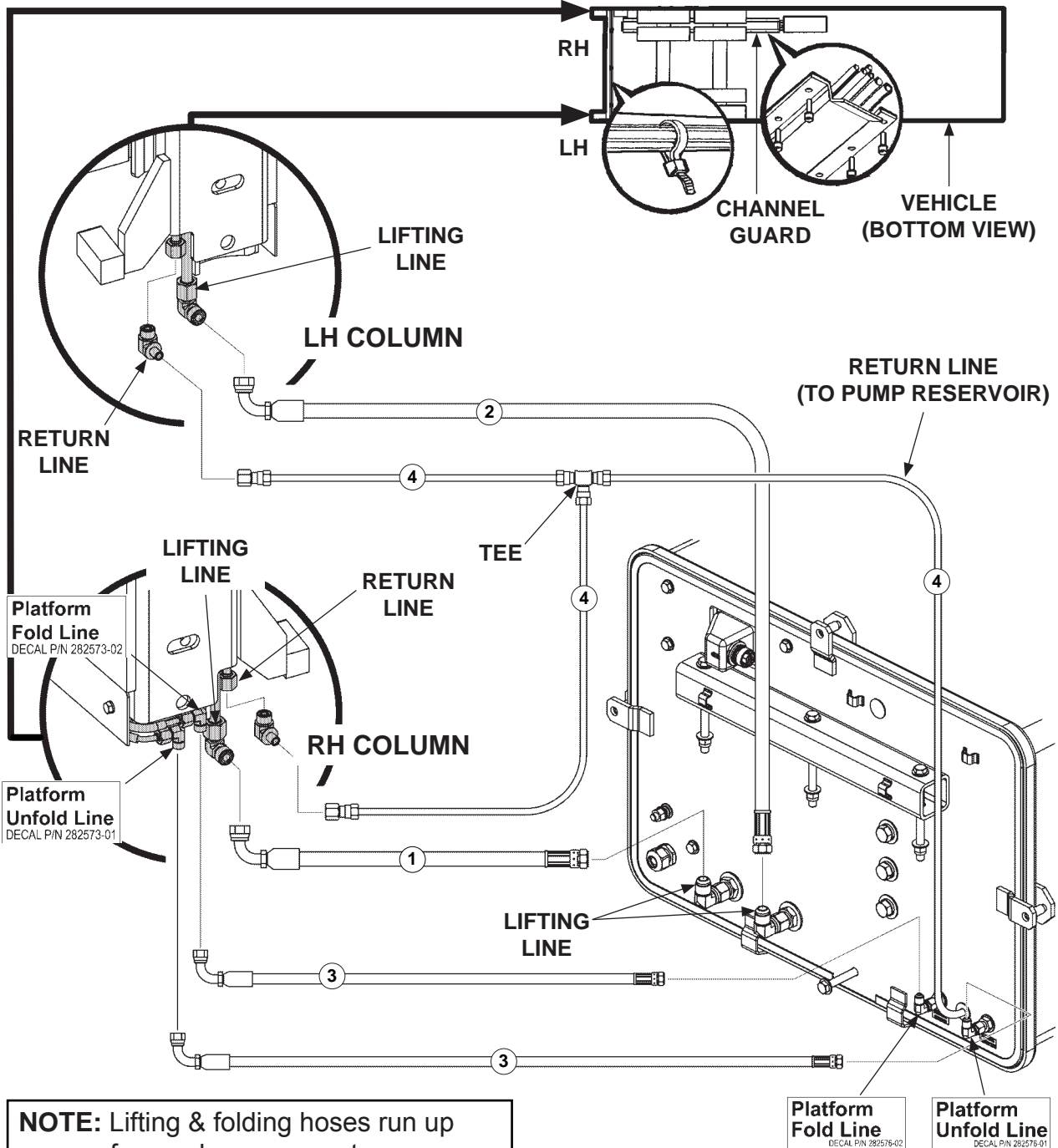

NOTE: Lifting & folding hoses run up from column connectors, as shown, to bottom of vehicle floor.

FIG. 48-1

11921 Slauson Ave. Santa Fe Springs, CA. 90670 (800) 227-4116 FAX (888) 771-7713
MAXON

STEP 8 - RUN HYDRAULIC LINES & ELECTRIC CABLES - Continued

RUN GRAVITY DOWN HYDRAULIC LINES

NOTE: Each pump extension kit contains 2 hoses of the same length (**item 3**). One hose is for the **Platform Fold Line** and the second hose is for the **Platform Unfold Line**. One hose has a yellow band on each connector to help connect the 2 hoses to the correct fittings. For example, connect hose with yellow bands to the **Fold Line** on the RH column and the **Fold Line** on the back of the pump box.

NOTE: For torque values for the hydraulic hose connectors, see **TABLES 50-1, 50-2 & 50-3**.

GRAVITY DOWN PUMP BOX INSTALLATION: REQUIRED HOSES & PLASTIC TUBING			
	3 FT.	10 FT.	15 FT.
1	HP 3/8" X 72" LG.	HP 3/8" X 196" LG.	HP 3/8" X 256" LG.
2	HP 3/8" X 150" LG.	HP 3/8" X 274" LG.	HP 3/8" X 334" LG.
3	HP 1/4" X 64" LG.	HP 1/4" X 188" LG.	HP 1/4" X 248" LG.
4	PLASTIC 3/8" OD X 84" LG.	PLASTIC 3/8" OD X 192" LG.	PLASTIC 3/8" OD X 264" LG.

TABLE 49-1

GRAVITY DOWN PUMP BOX INSTALLATION: REQUIRED HOSES & PLASTIC TUBING		
	20 FT.	28 FT.
1	HP 3/8" X 316" LG.	HP 3/8" X 412" LG.
2	HP 3/8" X 394" LG.	HP 3/8" X 490" LG.
3	HP 1/4" X 308" LG.	HP 1/4" X 404" LG.
4	PLASTIC 3/8" OD X 324" LG.	PLASTIC 3/8" OD X 420" LG.

TABLE 49-2

STEP 8 - RUN HYDRAULIC LINES & ELECTRIC CABLES

- Continued

TORQUE VALUES FOR HYDRAULIC CONNECTORS

SAE O-RING CONNECTORS

SIZE	TORQUE (LB-FT)	TORQUE (NEWTON-METER)
-4	13-15	17.6-20.3
-6	22-24	29.8-32.5
-8	40-43	54.2-58.3

TABLE 50-1

SAE 37 DEGREE FLARE CONNECTORS

SIZE	TORQUE (LB-FT)	TORQUE (NEWTON-METER)
-4	11-12	14.9-16.3
-6	18-20	24.4-27.1
-8	36-39	48.8-52.8

TABLE 50-2

O-RING FACE-SEAL CONNECTORS

SIZE	TORQUE (LB-FT)	TORQUE (NEWTON-METER)
-4	17-18	23-25.4
-6	25-27	33.9-37.3
-8	38-41	51.5-56.7

TABLE 50-3

STEP 8 - RUN HYDRAULIC LINES & ELECTRIC CABLES - Continued

RUN POWER DOWN HYDRAULIC LINES

NOTE: See TABLES 52-1 & 52-2 for information on the numbered hoses in this illustration.

CAUTION
Before connecting hoses, ensure face seal o-rings are in place.

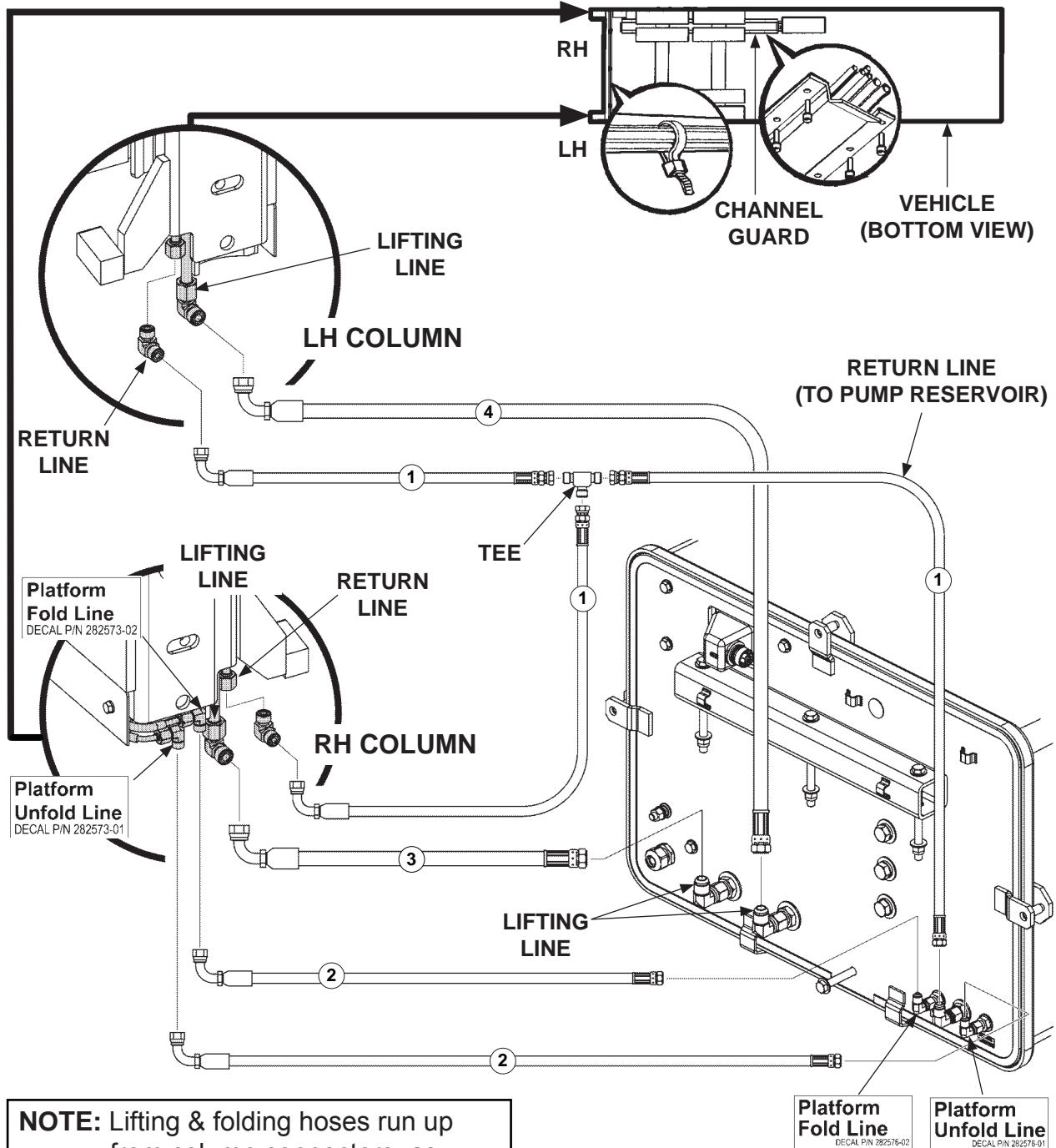

NOTE: Lifting & folding hoses run up from column connectors, as shown, to bottom of vehicle floor.

FIG. 51-1

STEP 8 - RUN HYDRAULIC LINES & ELECTRIC CABLES

- Continued

RUN HYDRAULIC LINES

NOTE: Each pump extension kit contains 2 hoses of the same length (**item 1**). One hose is for the **Platform Fold Line** and the second hose is for the **Platform Unfold Line**. One hose has a yellow band on each connector to help connect the 2 hoses to the correct fittings. For example, connect hose with yellow bands to the **Fold Line** on the RH column and the **Fold Line** on the back of the pump box.

NOTE: See **TABLES 50-1, 50-2 & 50-3** for hydraulic fittings torque values.

POWER DOWN PUMP BOX INSTALLATION: REQUIRED HOSES			
	3 FT.	10 FT.	15 FT.
1	HP 1/4" X 34" LG.	HP 1/4" X 166" LG.	HP 1/4" X 226" LG.
2	HP 1/4" X 64" LG.	HP 1/4" X 188" LG.	HP 1/4" X 248" LG.
3	HP 3/8" X 72" LG.	HP 3/8" X 196" LG.	HP 3/8" X 256" LG.
4	HP 3/8" X 150" LG.	HP 3/8" X 274" LG.	HP 3/8" X 334" LG.

TABLE 52-1

POWER DOWN PUMP BOX INSTALLATION: REQUIRED HOSES		
	20 FT.	28 FT.
1	HP 1/4" X 286" LG.	HP 1/4" X 382" LG.
2	HP 1/4" X 308" LG.	HP 1/4" X 404" LG.
3	HP 3/8" X 316" LG.	HP 3/8" X 412" LG.
4	HP 3/8" X 394" LG.	HP 3/8" X 490" LG.

TABLE 52-2

MAXON[®] 11921 Slauson Ave. Santa Fe Springs, CA. 90670 (800) 227-4116 FAX (888) 771-7713

STEP 8 - RUN HYDRAULIC LINES & ELECTRIC CABLES

- Continued

RUN ELECTRIC CABLES

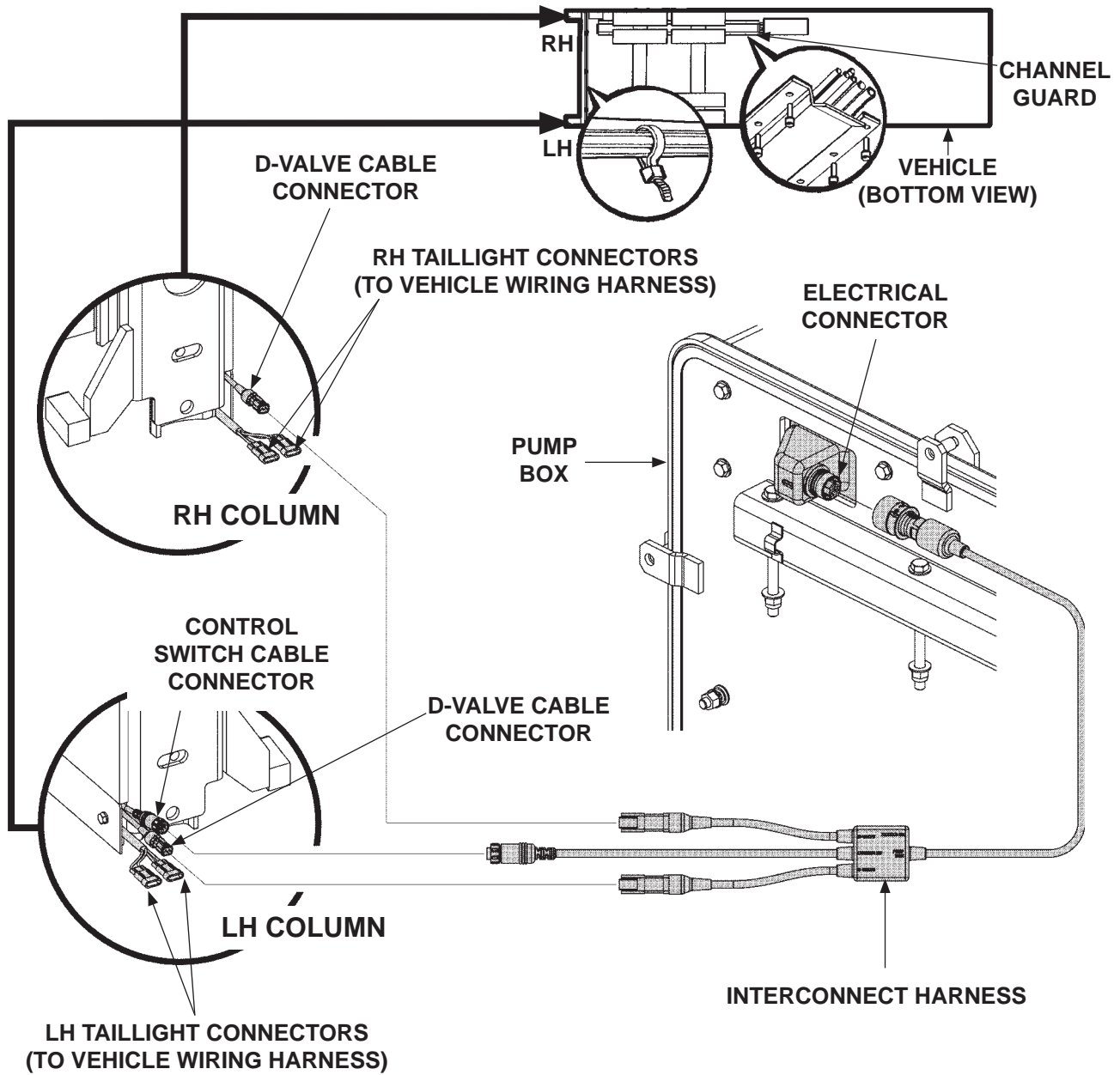

NOTE: Go to next page for more information about connecting & disconnecting twist-lock connectors.

FIG. 53-1

STEP 8 - RUN HYDRAULIC LINES & ELECTRIC CABLES - Continued

WIRING HARNESS TWIST-LOCK CONNECTORS

CAUTION

Before connecting, ensure connectors are clean inside. Ensure there is a thin coating of dielectric grease on face of receptacle, and there is no dielectric grease on connector contacts.

Refer to illustrations below for disconnecting, checking for dielectric grease, and reconnecting twist-lock style connectors.

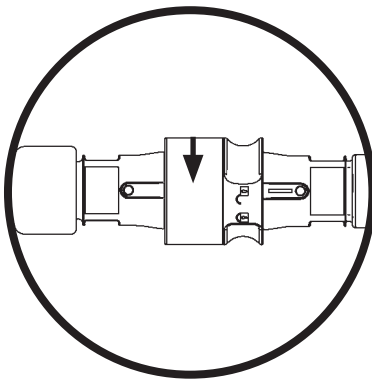

TWIST COUPLING RING TO UNLOCK
FIG. 54-1

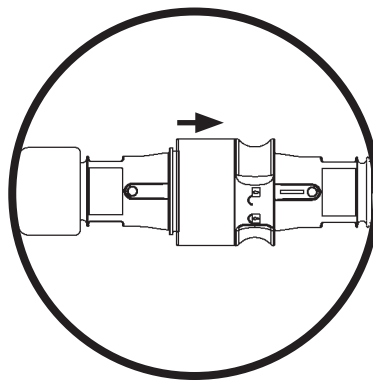

PULL COUPLING RING TO DISENGAGE
FIG. 54-2

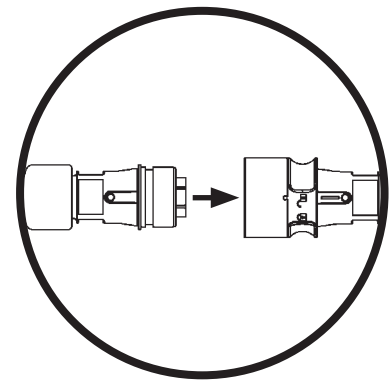

PULL CONNECTORS TO DISCONNECT
FIG. 54-3

ENSURE THERE IS A THIN COATING OF DIELECTRIC GREASE ON THIS SHADED AREA

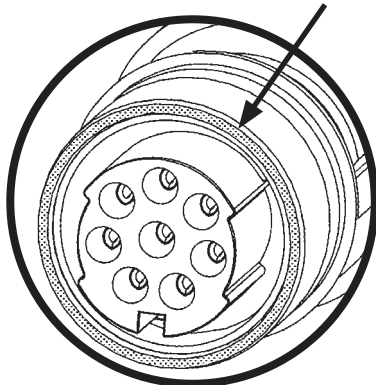

DIELECTRIC GREASE ON RECEPTACLE
FIG. 54-4

ALIGN MARKS

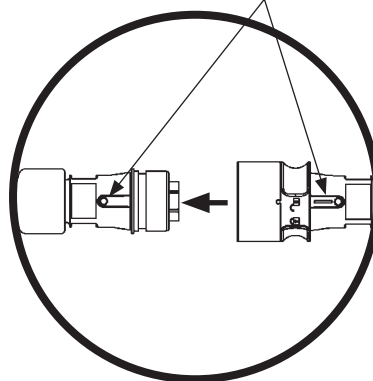

ALIGN & CONNECT
FIG. 54-5

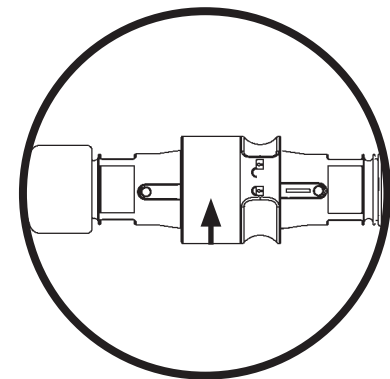

TWIST TO LOCK
FIG. 54-6

STEP 9 - GROUND PUMP TO VEHICLE FRAME

NOTE: Make sure the Liftgate power unit, all batteries on the vehicle for power unit, and taillights on Liftgate are connected correctly to a common ground.

1. Bolt ground cable to the ground stud on pump box (**FIG. 55-1**).

NOTE: If there is an existing grounding point on truck frame, use it to connect ground cable and skip the step for drilling a hole.

2. Extend the ground cable to reach vehicle frame (**FIG. 55-1B**) without putting tension on cable (after connection). Connect to an existing grounding point if available.
3. If necessary, drill a $11/32"$ ($0.343"$) hole in vehicle frame for bolting the ground cable terminal lug (**FIG. 55-1B**).

NOTE:

- Before connecting ground cable to frame, clean connection point on the frame down to bare metal.
- After connecting ground cable, **MAXON** recommends sealing the ground connection with galvanized coating for galvanized surfaces, or black paint for painted surfaces.

4. Bolt ground cable terminal lug (**FIG. 55-1A**) to vehicle frame as shown in **FIG. 55-1B**.

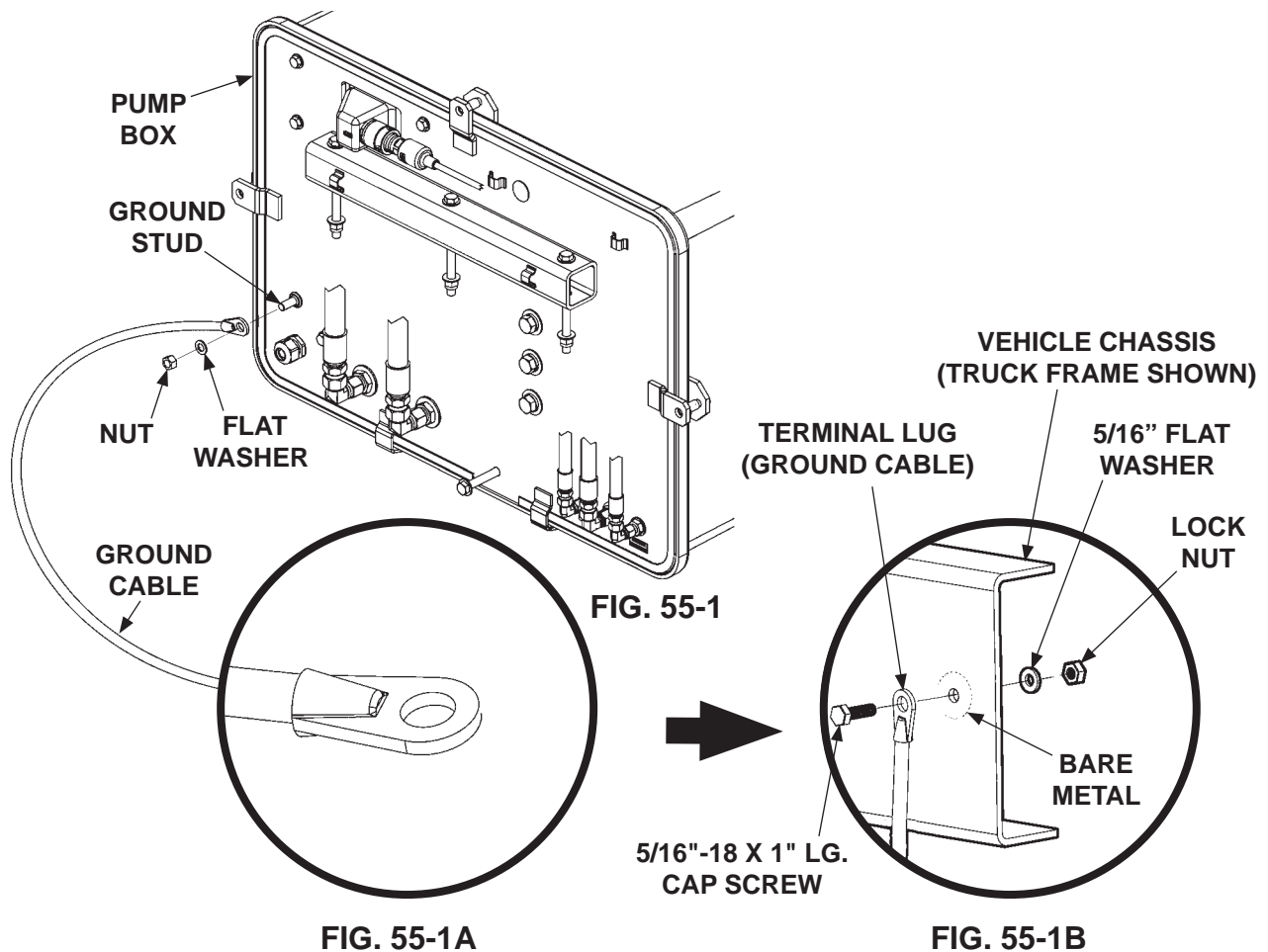

STEP 10 - RUN CHARGE LINES

RECOMMENDED POWER CONFIGURATIONS

⚠ CAUTION

Never route an energized wire. Make sure battery is disconnected. Always route electrical wires clear of moving parts, brake lines, sharp edges and exhaust systems. Avoid making sharp bends in wiring. Attach securely. If drilling is necessary, first check behind the drilling surface so you do not damage any fuel lines, vent lines, brake lines or wires.

NOTE: Make sure the power unit for the Liftgate, and all batteries on the vehicle used as the power source, are connected correctly to a common chassis ground.

1. Liftgate, pump box, and battery box are typically installed on trailers as shown in **FIG. 56-1**.

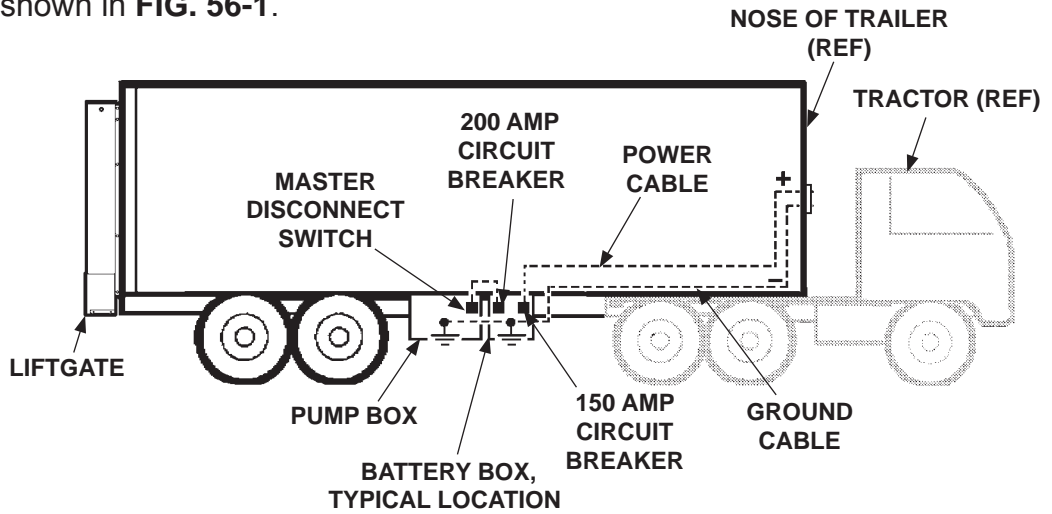

**RECOMMENDED LIFTGATE & BATTERY BOX
INSTALLATION ON TRAILER
FIG. 56-1**

STEP 10 - RUN CHARGE LINES - Continued

2. Liftgate, pump box, and optional battery box are typically installed on trucks as shown in FIG. 57-1 and FIG. 57-2. See the following page for battery and cable connections.

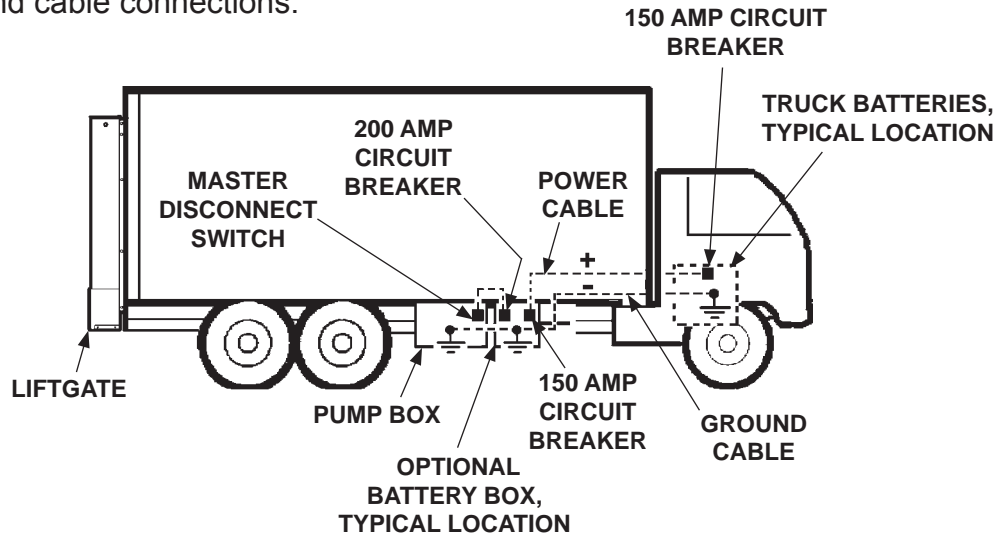

**RECOMMENDED LIFTGATE & BATTERY BOX
INSTALLATION ON TRUCK
FIG. 57-1**

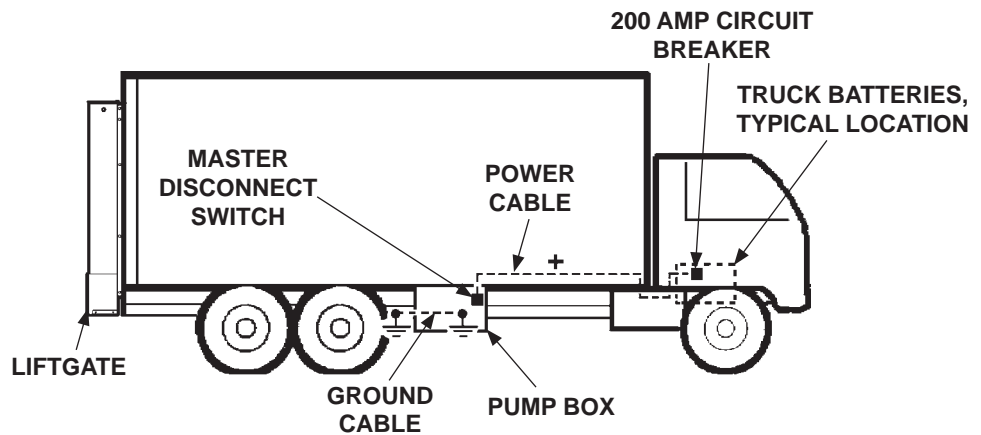

**RECOMMENDED LIFTGATE INSTALLATION
WITHOUT OPTIONAL BATTERY BOX
FIG. 57-2**

STEP 10 - RUN CHARGE LINES - Continued

RUNNING CABLE FROM VEHICLE BATTERY

NOTE: Make sure cable is long enough to reach master disconnect switch on Lift-gate pump box, or circuit breaker in optional battery box (if equipped), without putting strain on the cable. If equipped with fused cable, ensure the **fuse** end is by the vehicle battery.

1. Install charge line by running the line along vehicle frame as follows.

- Inside of truck frame (**FIG. 58-1**)
- Bottom of trailer frame

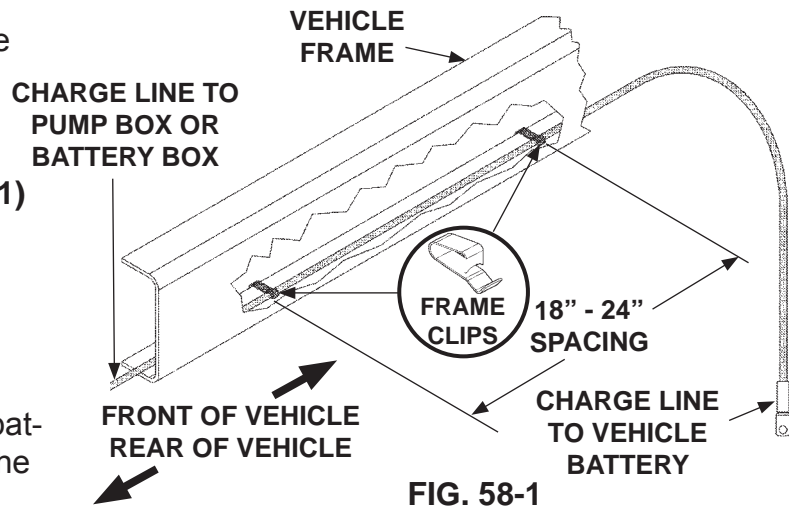

FIG. 58-1

2. Run the charge line from truck battery or nose of trailer to one of the following devices.

- Master disconnect switch on pump box (**FIG. 58-2**)
- The 150 amp circuit breaker in optional battery box (**FIG. 58-3**)

Use frame clips (Parts Box item) (**FIG. 58-1**) and plastic ties, as required from charge line kit, to secure cable to vehicle.

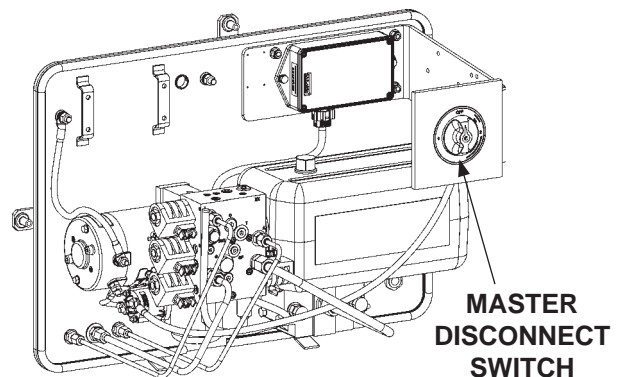

FIG. 58-2

3. If Liftgate comes with:

- Single Pole Tractor Charge Line Kit
- Single Pole Trailer Charge Line Kit
- Dual Pole Tractor Charge Line Kit
- Dual Pole Trailer Charge Line Kit

Install charge line according to **Instruction Sheet** contained in each kit.

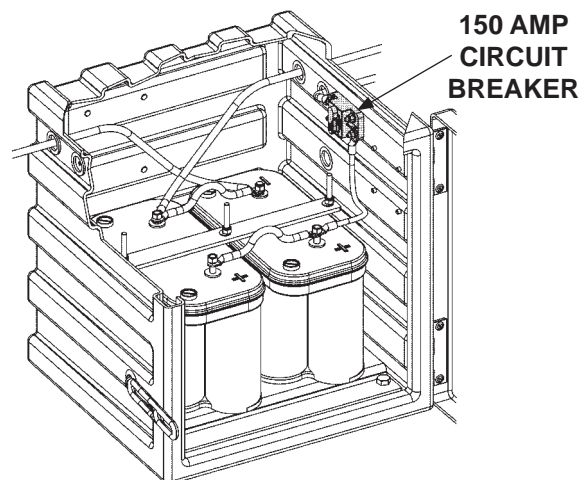

FIG. 58-3

STEP 11 - CONNECT CHARGE LINES & BATTERIES

⚠ WARNING

Prevent injury and equipment damage. Before connecting charge lines or power cables, ensure negative (-) battery cable is disconnected at vehicle battery or battery box (if equipped). Ensure master disconnect switch is turned OFF on the pump box.

NOTE: Ensure batteries are fully charged before operating Liftgate & before delivery to customer.

1. Remove nut from negative (-) battery terminal. Disconnect negative (-) battery cable from vehicle battery (FIG. 59-1). Start nut on the terminal.

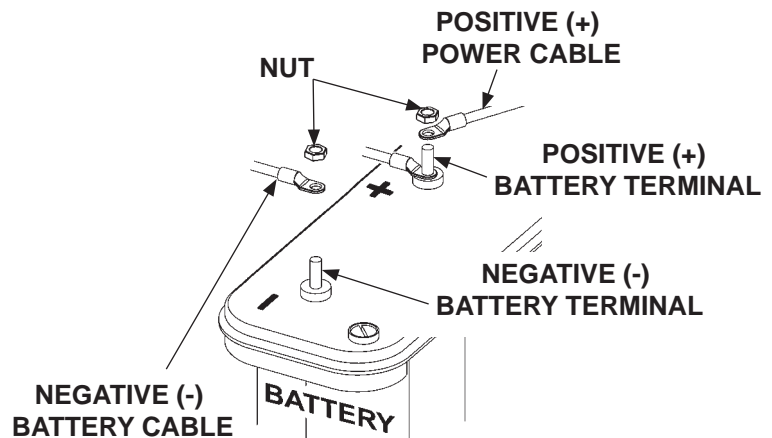

CONNECTING CHARGE LINE TO BATTERY
FIG. 59-1

2. Remove nut from positive (+) battery terminal. Connect positive (+) power cable (charge line) to positive (+) battery terminal (FIG. 59-1). Reinstall and tighten nut.

NOTE: Skip instruction 3 below if connecting to optional battery box.

3. If **vehicle batteries** are used to power the Liftgate, do the following. At the pump box, remove nut from **OUTPUT** terminal on master disconnect switch (FIG. 59-2). Connect positive (+) power cable (charge line) to **OUTPUT** terminal on master disconnect switch (FIG. 59-2). Reinstall and tighten nut.

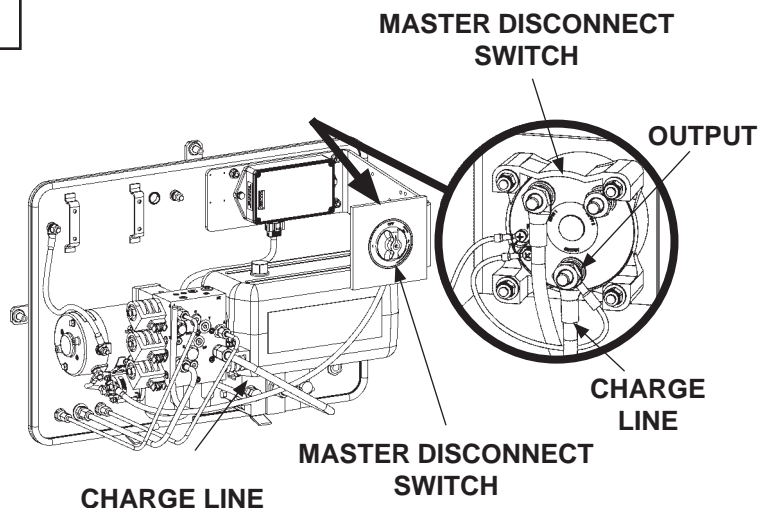

CONNECTING CHARGE LINE TO MASTER DISCONNECT SWITCH
FIG. 59-2

STEP 11 - CONNECT CHARGE LINES & BATTERIES - Continued

NOTE: Skip instruction 4 below if vehicle battery is connected to master disconnect switch on the pump box.

4. If optional battery box is installed for the Liftgate, the battery box is mounted in one of 2 ways.

- Pump box and battery box are mounted together in a dual frame (FIG. 60-1). The red (+) and black (-) cables, connecting battery box to pump box, are connected at the factory. **Go to instruction .**

- Pump box and battery box are mounted separately in 2 single frames (FIG. 60-2). The red (+) and black (-) cables, connecting battery box to pump box, need to be connected by the installer. **Go to instruction 5.**

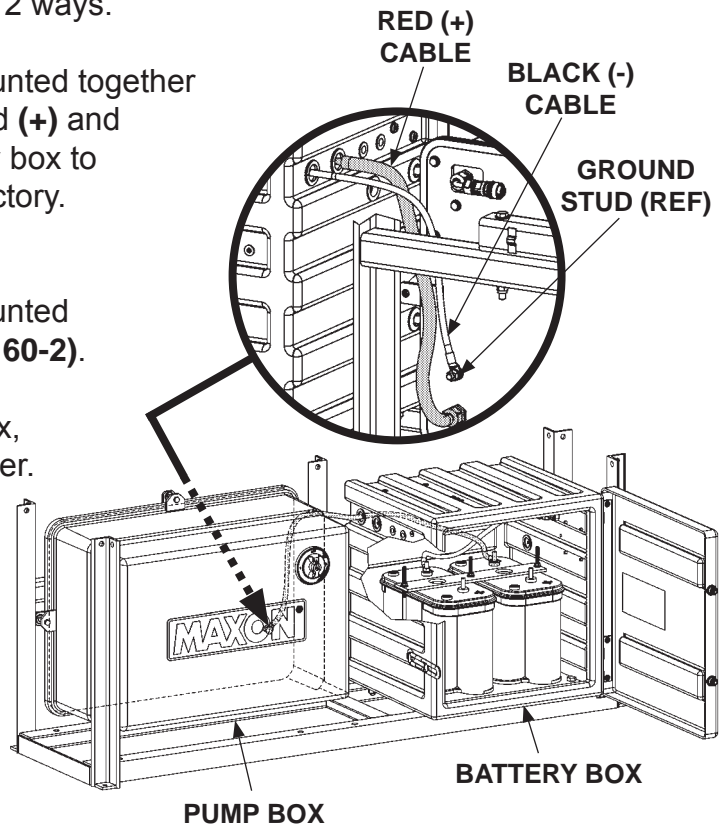

**PUMP BOX & BATTERY BOX IN DUAL FRAME
FIG. 60-1**

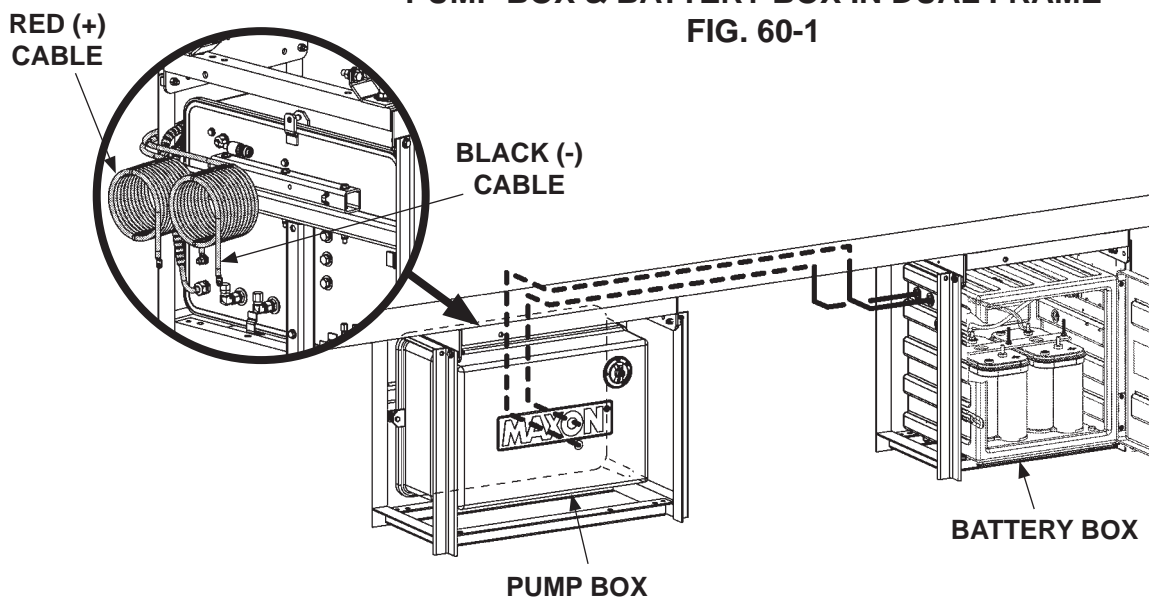

**PUMP BOX & BATTERY BOX IN DUAL FRAME
FIG. 60-2**

STEP 11 - CONNECT BATTERIES TO LIFTGATE - Cont'd

NOTE: The following instructions are only required if Liftgate is equipped with optional battery box, and the pump box and battery box are mounted in separate single frames. In the dual frame shown below, the power cable is connected between pump box and battery box at the factory.

5. Uncoil the red (+) cable from back of the pump box (FIG. 61-1). Next, run cable along vehicle frame, through grommet on battery box, and to the 200 amp circuit breaker inside battery box (FIG. 61-2).

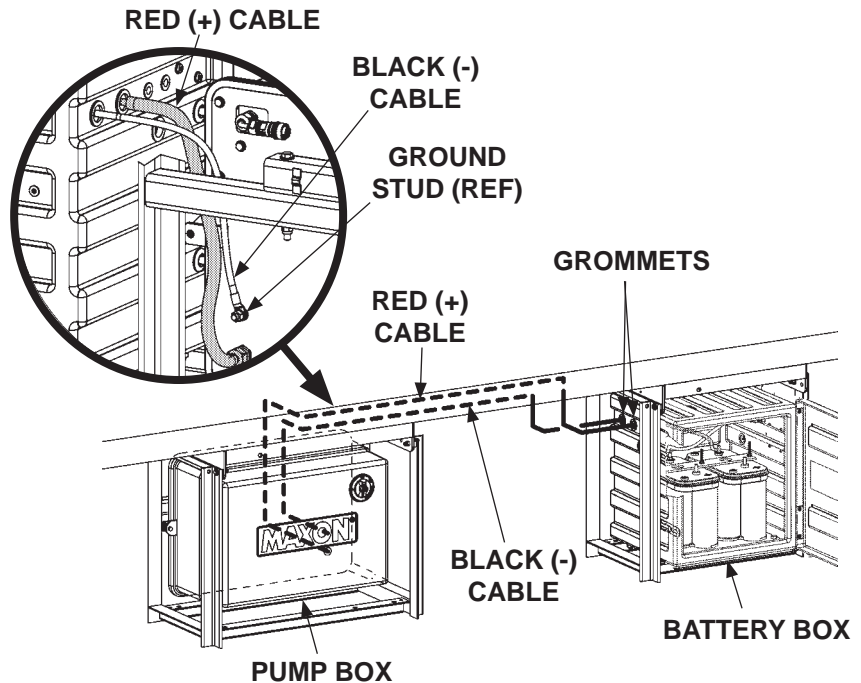

**PUMP BOX & BATTERY BOX IN SINGLE FRAMES
FIG. 61-1**

6. Uncoil the black (-) cable from back of the pump box (FIG. 61-1). Next, run cable along vehicle frame, through grommet on battery box, and to the negative (-) battery terminal inside battery box (FIG. 61-2).

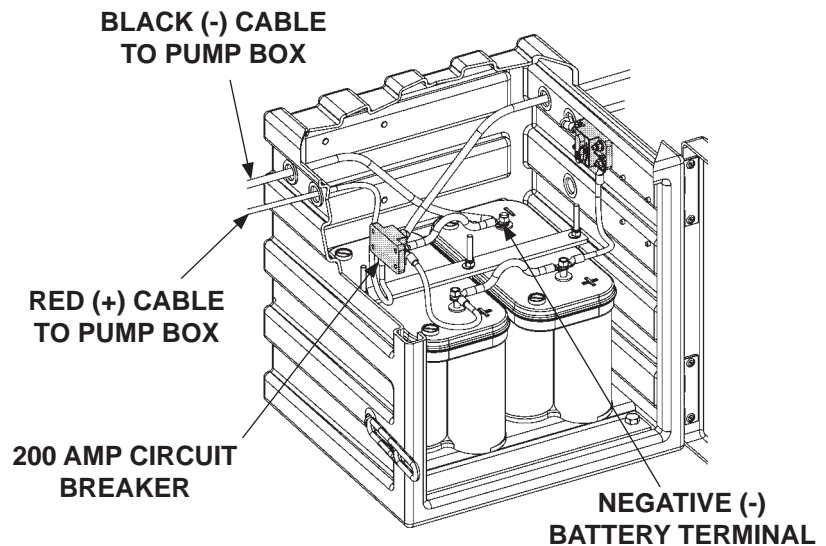

**ELECTRICAL CONNECTIONS IN BATTERY BOX
FIG. 61-2**

STEP 11 - CONNECT BATTERIES TO LIFTGATE - Cont'd

7. Remove nut and washer from unused terminal on **200 amp** circuit breaker (FIG. 62-1). Then, connect red (+) cable to the terminal. Reinstall and tighten nut.

8. Remove nut from negative (-) battery terminal (FIG. 62-2). Then, connect black (-) cable to negative (-) battery terminal. Reinstall and tighten nut.

9. Remove nut and washer from unused terminal on **150 amp** circuit breaker (FIG. 62-1). Then, connect charge line to the terminal. Reinstall and tighten nut.

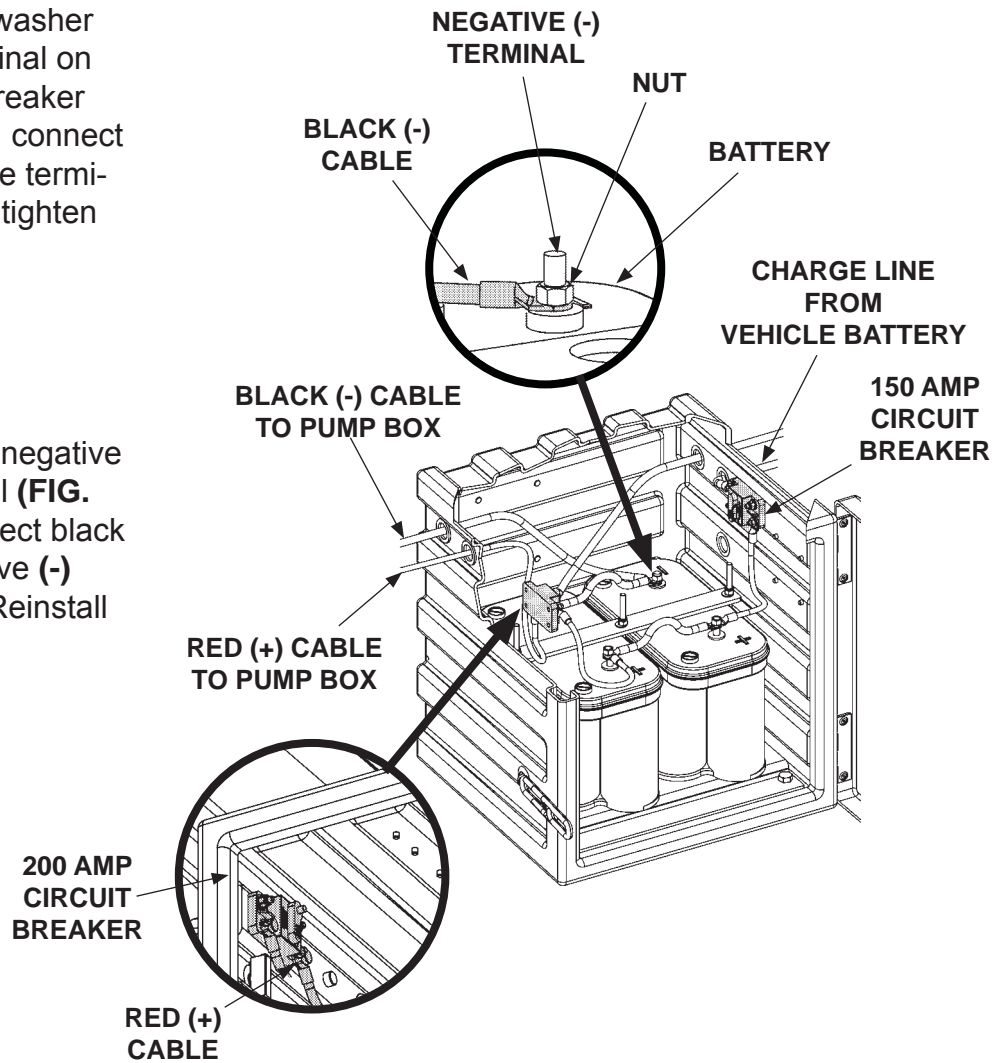

CONNECTING RED & BLACK CABLES AND CHARGE LINE
FIG. 62-1

STEP 12 - PRESSURIZE HYDRAULIC SYSTEM

⚠ WARNING

To prevent injury and equipment damage, pressurize hydraulic system before removing lower support fixtures and operating Liftgate.

NOTE: Before operating liftgate, read and understand the operating instructions in the **Operation Manual**.

1. To pressurize lifting cylinders, set control box toggle switch to **UP** for 10-15 seconds as shown in **FIG. 63-1**.

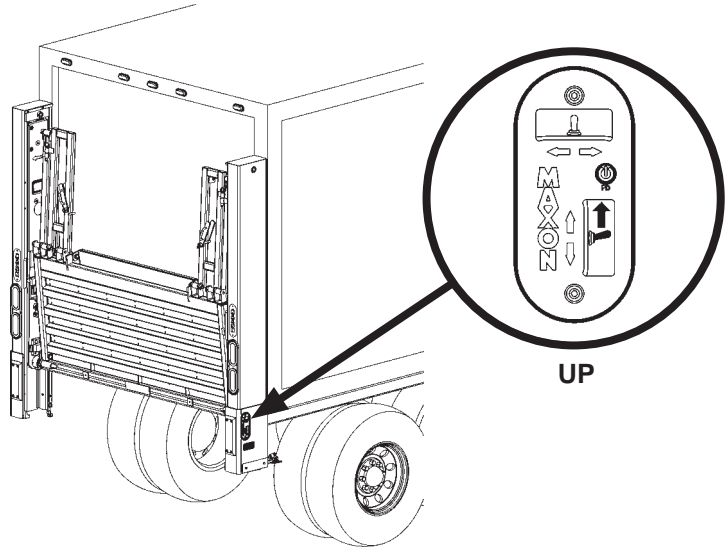

PRESSURIZING LIFTING CYLINDERS
FIG. 63-1

2. To pressurize closing cylinder, set control box toggle switches to **FOLD** for 10-15 seconds as shown in **FIG. 63-2**.

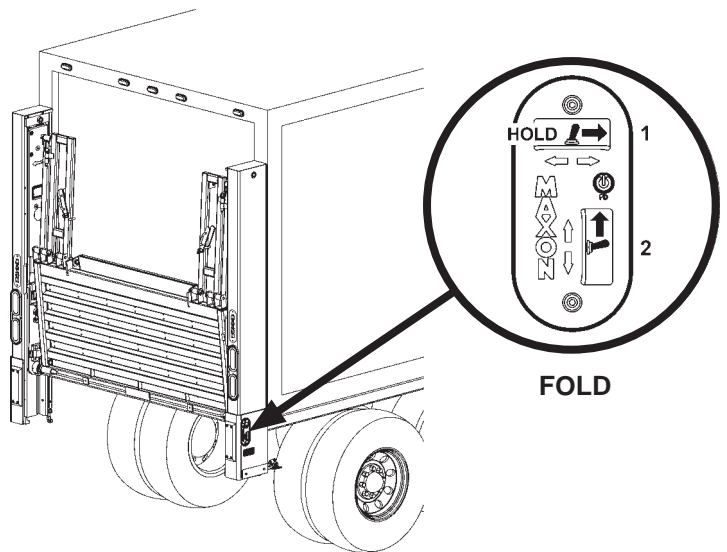

PRESSURIZING CLOSING CYLINDER
FIG. 63-2

NOTE: Liftgate is shipped with **Exxon Unavis HVI-13** hydraulic fluid in the hydraulic cylinders. This fluid is suitable for operation in temperature range of **-40° F to +120° F**. If necessary, a different brand or higher viscosity hydraulic fluid may be used. Refer to the **CHANGING HYDRAULIC FLUID** procedure in the **BMR Maintenance Manual**.

STEP 13 - OPTIMIZE HYDRAULIC FLUID LEVEL

NOTE: If equipped, select **power down on demand** for optimizing hydraulic fluid level (FIG. 64-1).

1. Lower (**DOWN**) the platform 9" to 12" using toggle switch settings shown in FIG. 64-1.

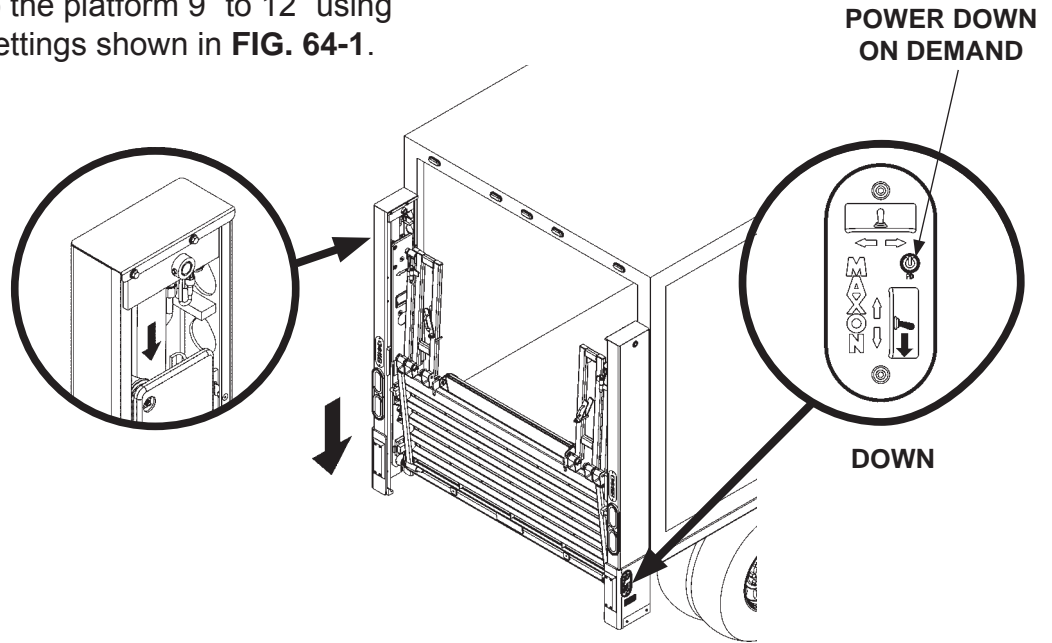

LOWERING PLATFORM
FIG. 64-1

2. Open (**UNFOLD**) the platform by setting toggle switches as shown in FIG. 64-2.

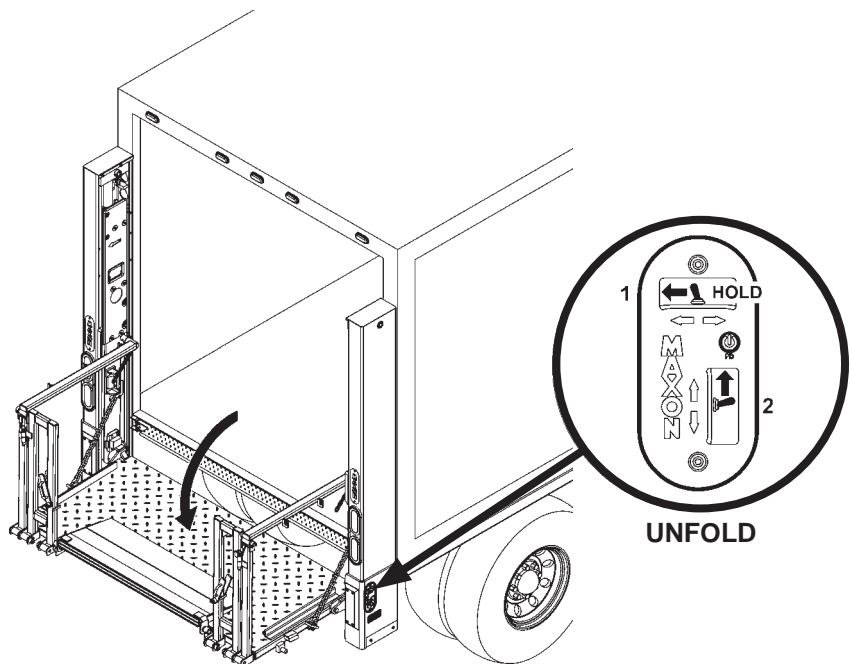

UNFOLDING PLATFORM
FIG. 64-2

STEP 13 - OPTIMIZE HYDRAULIC FLUID LEVEL - Continued

3. Close (**FOLD**) the platform by setting toggle switches as shown in **FIG. 65-1**. Then, open (**UNFOLD**) the platform by setting toggle switches as shown in **FIG. 65-2**.

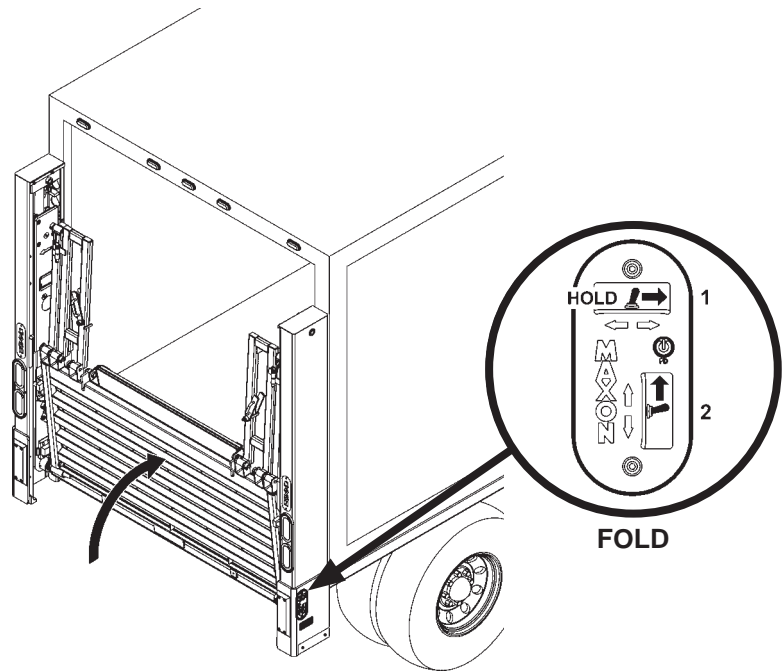

FOLDING PLATFORM
FIG. 65-1

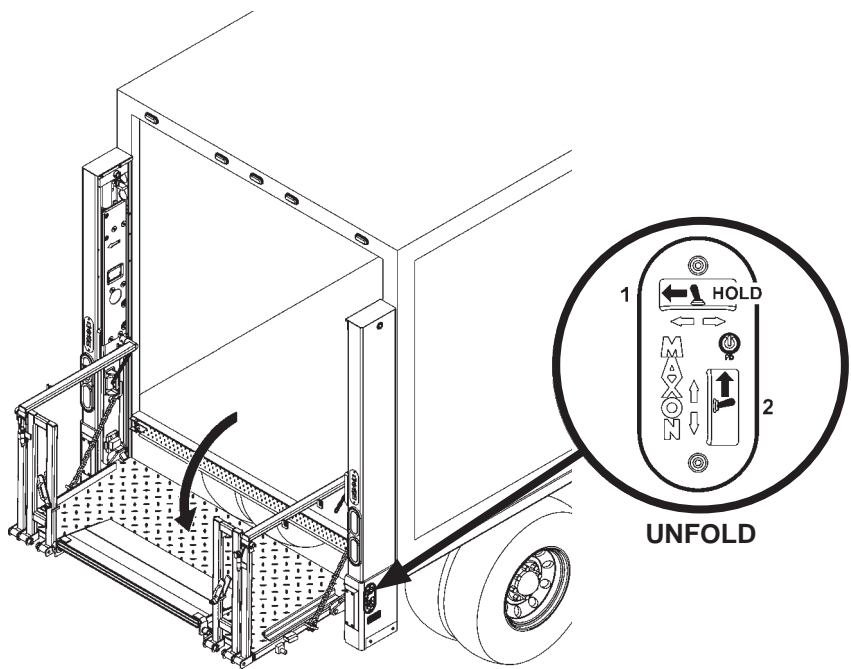

UNFOLDING PLATFORM
FIG. 65-2

STEP 13 - OPTIMIZE HYDRAULIC FLUID LEVEL - Continued

4. Lower (**DOWN**) the platform to 10" above ground level using the toggle switch settings shown in **FIG. 66-1**.

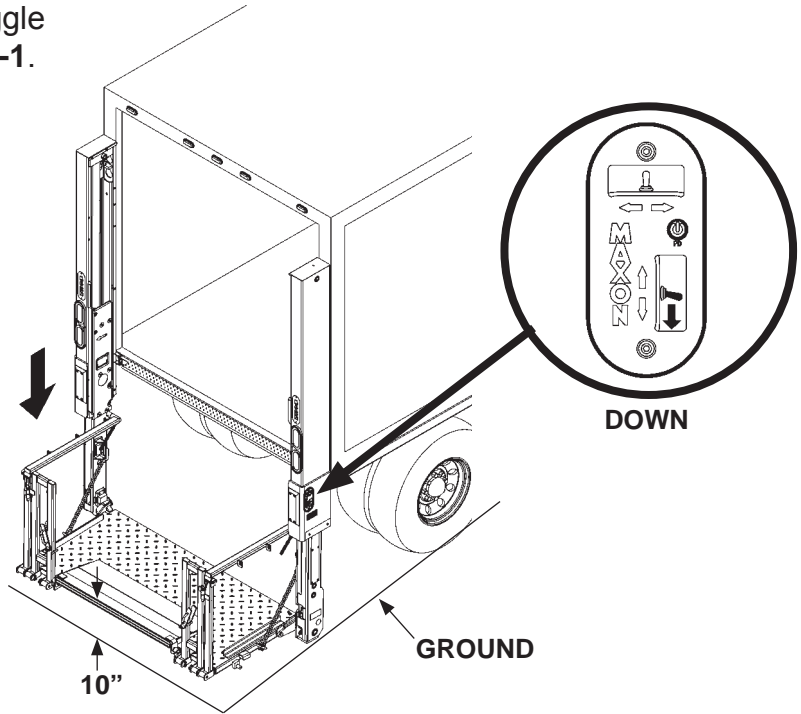

**LOWERING PLATFORM
FIG. 66-1**

5. Raise (**UP**) the platform to about 6" below bed height using toggle switch setting shown in **FIG. 66-2**.

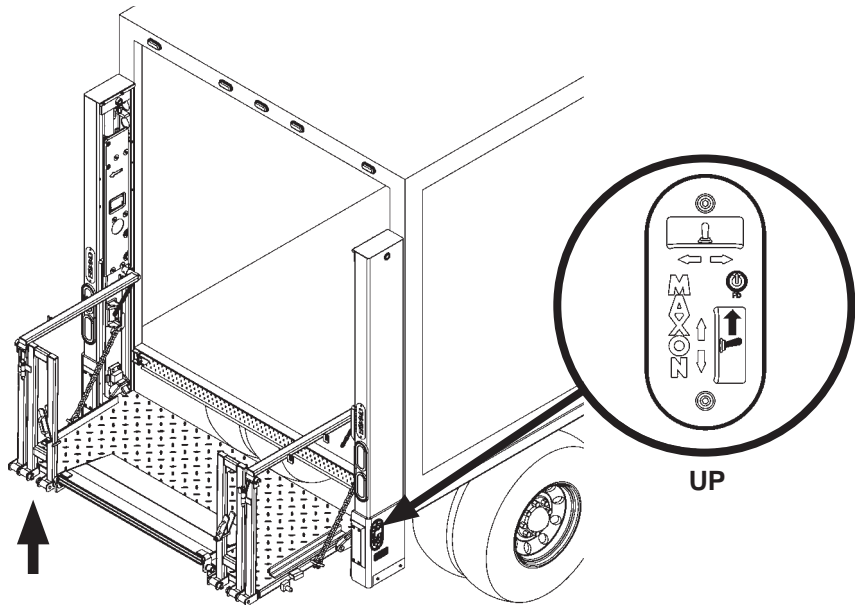

**RAISING PLATFORM
FIG. 66-2**

STEP 13 - OPTIMIZE HYDRAULIC FLUID LEVEL - Continued

6. Close (**FOLD**) the platform by setting toggle switches as shown in **FIG. 67-1**.

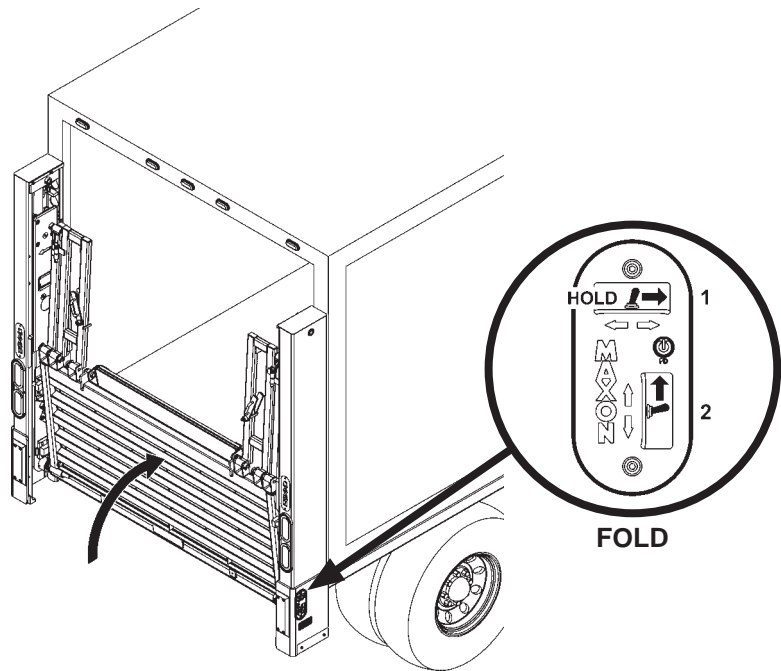

FOLDING PLATFORM
FIG. 67-1

7. Raise (**UP**) the runners to stow platform by setting toggle switches as shown in **FIG. 67-2**.

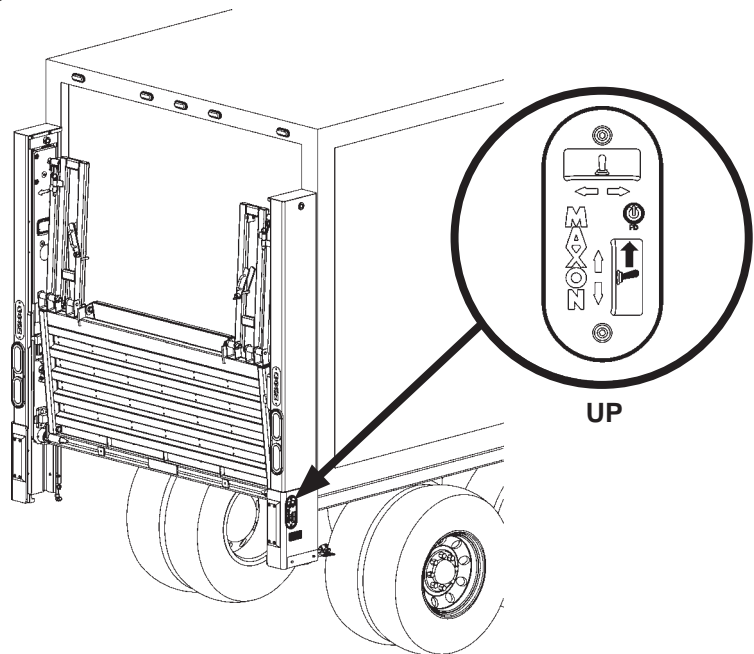

RAISING PLATFORM
FIG. 67-2

STEP 13 - OPTIMIZE HYDRAULIC FLUID LEVEL - Continued

NOTE: Information for checking hydraulic fluid level is shown on a decal on the pump reservoir.

8. Check if hydraulic fluid level is at the full line (**FIG. 68-1**). If necessary, remove filler cap (**FIG. 68-1**) and add hydraulic fluid until level rises to the full line (**FIG. 68-1**). Then, reinstall filler cap (**FIG. 68-1**).

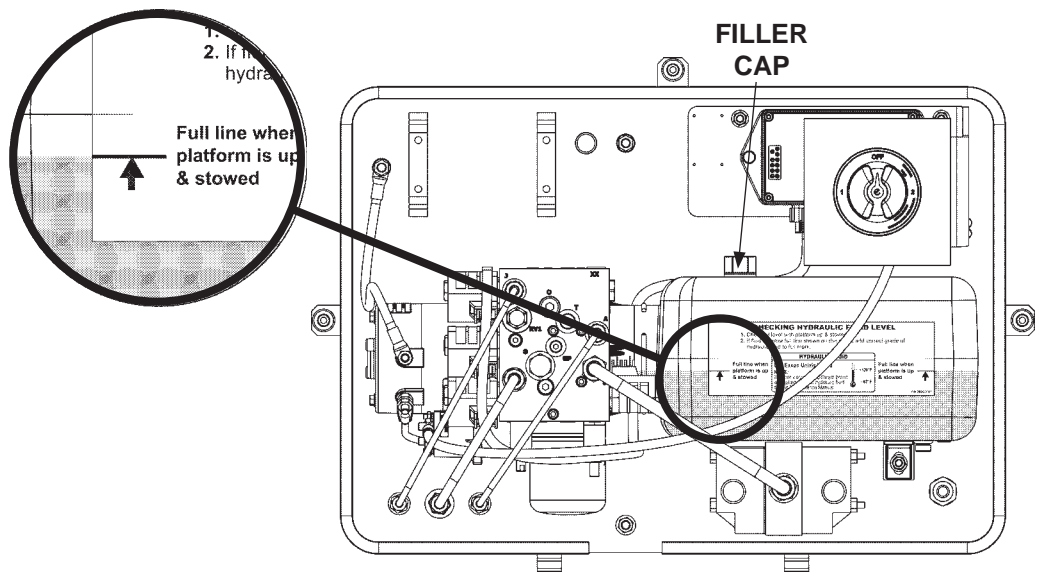

**CHECKING HYDRAULIC FLUID LEVEL
FIG. 68-1**

STEP 14 - REMOVE UPPER SUPPORT FIXTURES

⚠ CAUTION

Upper support fixtures are heavy. To prevent injury to installer and damage to Liftgate, use forklift or hoist to hold support fixtures during removal.

1. Stow the platform as shown in **FIG. 69-1**.
2. Position forklift or hoist to hold upper support fixtures as shown in **FIG. 69-1**.
3. Unbolt the 2 upper support fixtures from the LH column (**FIGS. 69-1 and 69-1A**). Repeat for RH column. Use forklift to remove upper support fixtures from work area.

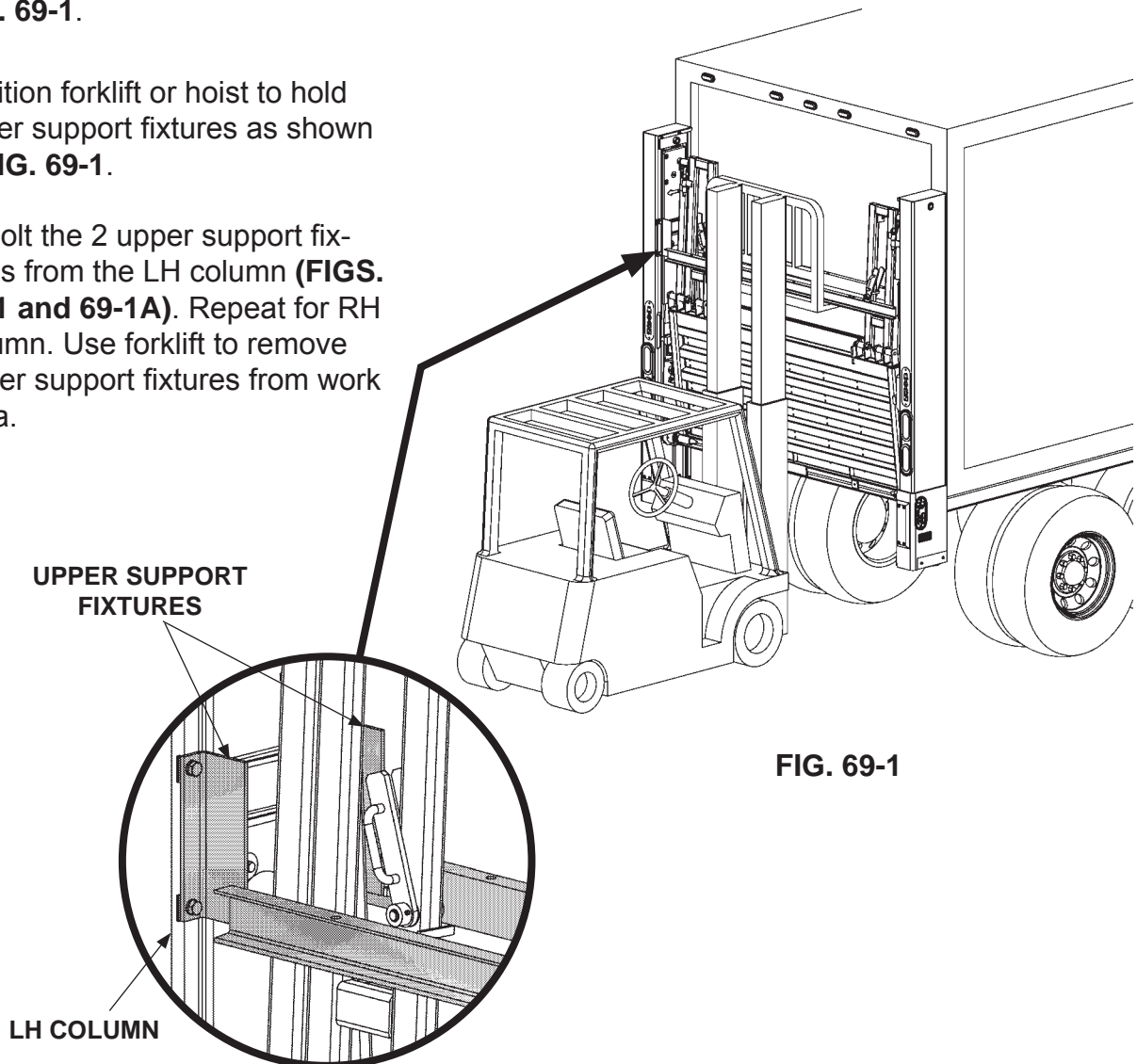

FIG. 69-1

FIG. 69-1A

STEP 15 - SECURING COLUMNS METHOD 1 & METHOD 2

NOTE: Skip this step if using the **METHOD 3** weld-on version of installation with no mounting plates.

1. Slightly lower and open platform for access to mounting pin.
2. Get (2) lock plates and (2) 1"-8 lock nuts from parts bag. Then, install (1) lock plate and (1) lock nut to top rear guide on the mounting plate on the LH column (**FIGS. 70-1 and 70-1A**). Torque lock nut to **200 lb-ft**. Repeat for RH column.

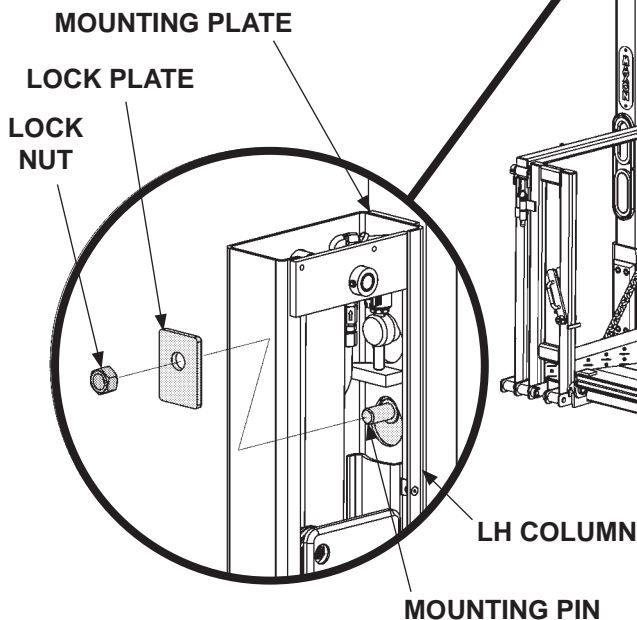

**INSTALLING LOCK PLATE
FIG. 70-1A**

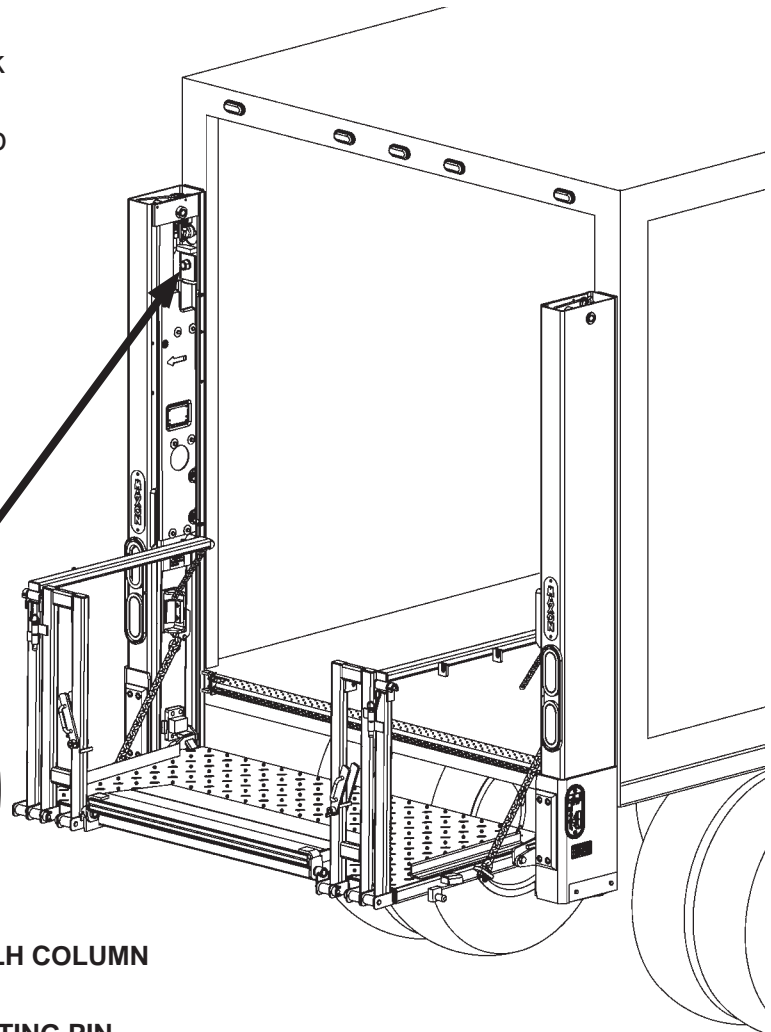

FIG. 70-1

STEP 15 - SECURING COLUMNS - Continued

METHOD 1 ONLY

NOTE: Skip 3 and 4 if using **METHOD 2** or **METHOD 3** to install Liftgate on vehicle.

3. Tighten cap screw against bolt guide in LH column (**FIGS. 71-1 and 71-1A**). Torque cap screw to **170 lb-ft**. Repeat for RH column.

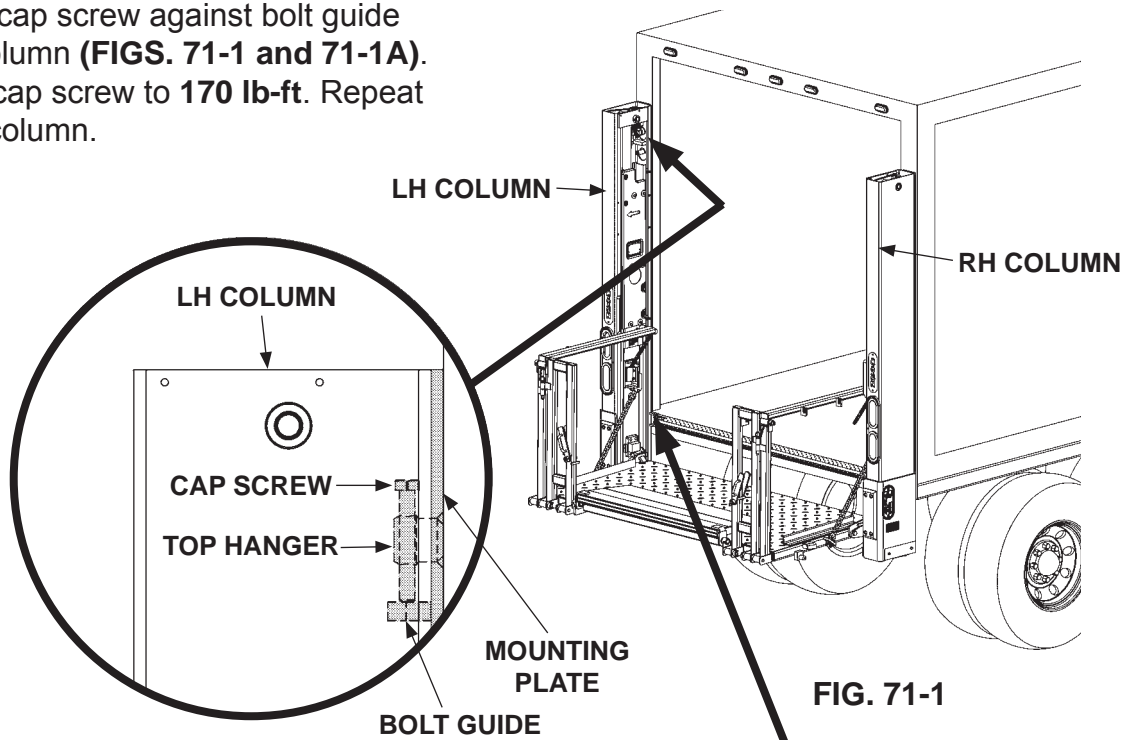

TIGHTENING HANGER CAP SCREW (LH COLUMN SHOWN)
FIG. 71-1A

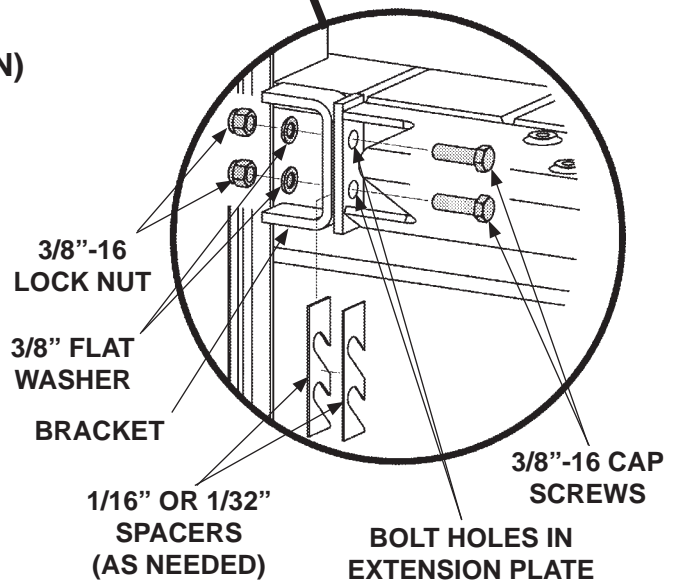

BOLTING EXTENSION PLATE, IF NEEDED (LH COLUMN SHOWN)
FIG. 71-1B

NOTE: For **METHOD 1**, bolting extension plate to LH & RH columns is not required. However, extension plate may be bolted to LH & RH columns, if needed, and if the bracket holes are aligned correctly.

4. If needed, fill gap between LH column bracket and extension plate with spacers (**FIGS. 71-1 and 71-1B**). Then, bolt extension plate to column. Torque 3/8"-16 cap screws and lock nuts **35-52 lb-ft**. Repeat for RH column.

STEP 15 - SECURING COLUMNS - Continued

METHOD 1 & METHOD 2

NOTE: Skip this step if using the **METHOD 3** weld-on version of installation with no mounting plates.

NOTE: MAXON recommends using the upper bolt hole (**FIG. 72-1A**) to attach mounting plate. However, if the upper hole will be covered by vehicle corner post, then use the lower bolt hole (**FIG. 72-1B**).

5. Get (2) flange hex bolts, (2) flange lock nuts (if needed), and (2) flat washers (if needed) from parts bag. Then, install (1) bolt, (1) nut (if needed), and (1) flat washer (if needed) through mounting plate and RH column (**FIGS. 72-1, 72-1A and 72-1B**) Repeat for LH column.

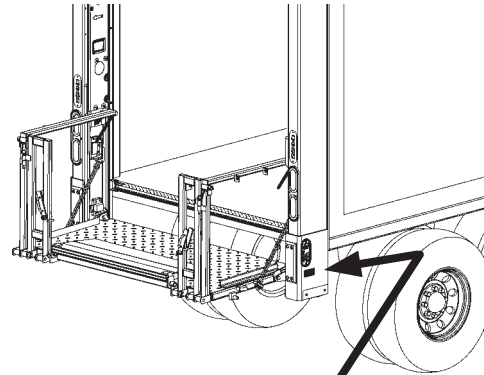
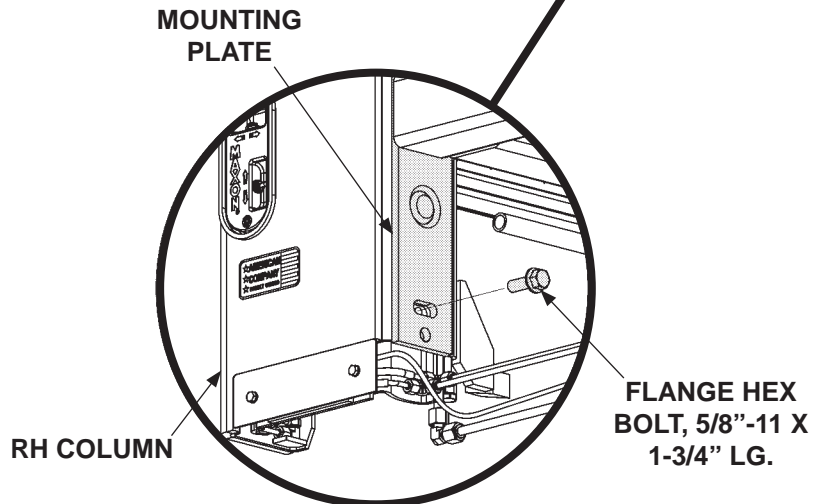
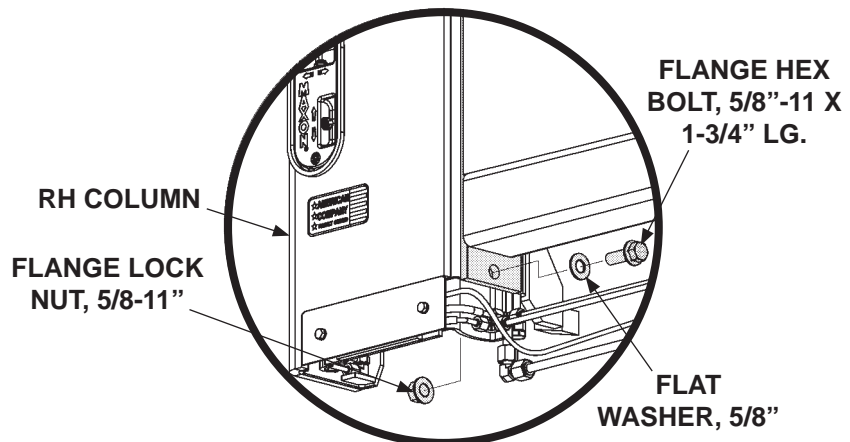

FIG. 72-1



**UPPER BOLT HOLE
FIG. 72-1A**

6. Torque 5/8"-11 bolts to **170 lb-ft**. Repeat for LH column.



**LOWER BOLT HOLE
FIG. 72-1B**

STEP 15 - SECURING COLUMNS - Continued

METHOD 1 & METHOD 2

NOTE: Skip this step if using the **METHOD 3** weld-on installation with no mounting plates.

7. Reinstall RH top column cover, screws, lock washers and flat washers (**FIGS. 73-1 and 73-1A**). Tighten screws, then repeat for LH top column cover.

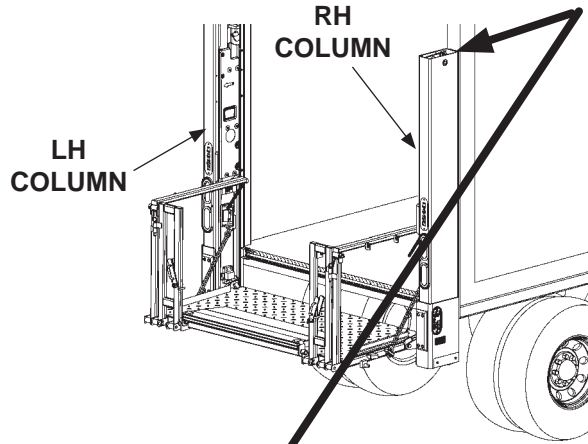
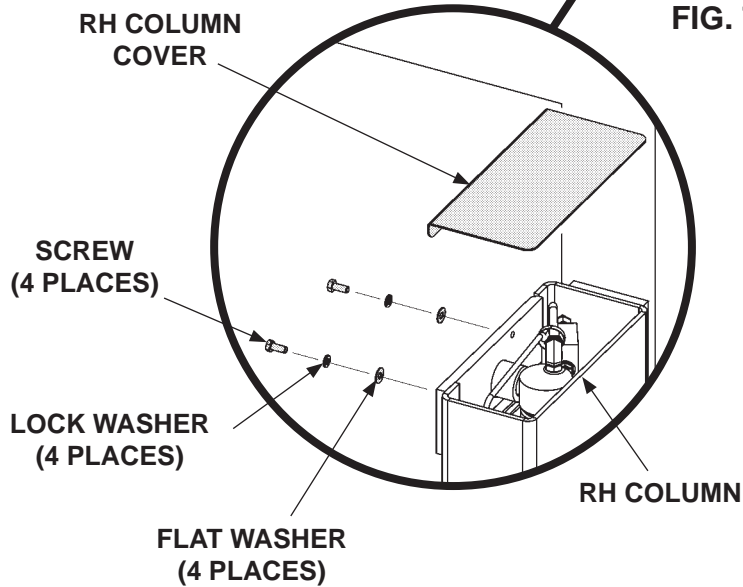

FIG. 73-1



REINSTALLING RH COLUMN COVER
FIG. 73-1A

STEP 16 - FINISH WELDING LIFTGATE TO VEHICLE METHOD 2 & METHOD 3 - WELD LIFTGATE TO BODY

NOTE: Skip this step if using **METHOD 1** installation where mounting plates and extension plate are preinstalled on vehicle.

1. Check operation of Liftgate before final welding. See **BMR-CS Operation Manual**.

⚠ WARNING

To prevent accidental personal injury and equipment damage, disconnect (-) battery cable and (+) cable from battery.

2. Disconnect power to the pump by disconnecting negative (-) and positive (+) cables from battery (**FIG. 74-1**). Reinstall nuts on negative (-) and positive (+) battery terminals.

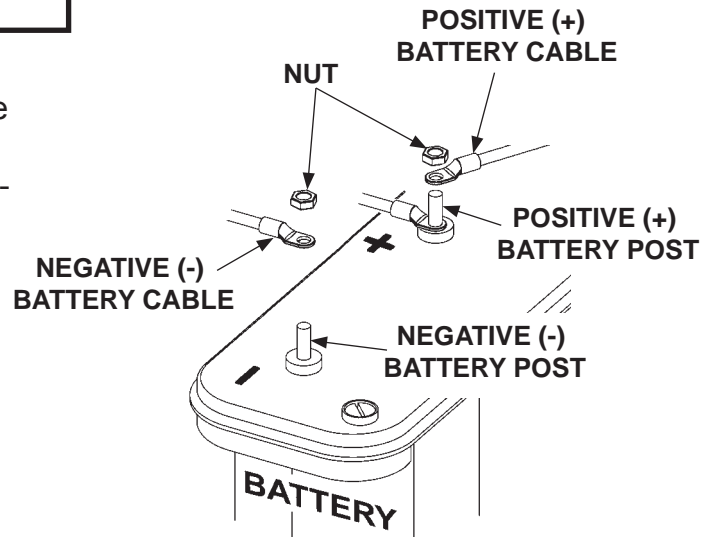

**DISCONNECTING BATTERY POWER
FIG. 74-1**

STEP 16 - FINISH WELDING LIFTGATE TO VEHICLE METHOD 2 & METHOD 3 - WELD LIFTGATE TO BODY - Continued

⚠ WARNING

Recommended practices for welding on steel parts are contained in the current AWS (American Welding Society) D1.1 Structural Welding Code - Steel. Damage to Liftgate and/or vehicle, and personal injury can result from welds that are done incorrectly.

NOTE: If Liftgate columns cannot be mounted flush against rear of vehicle, a filler such as tubing, channel, or plate stock may be used to bridge gap between vehicle body and Liftgate columns. Make sure the added materials and welds meet the **BODY STRENGTH REQUIREMENTS** indicated in this manual.

CAUTION

To prevent damage to Liftgate:

- Connect welder ground to vehicle body.
- Protect hydraulic hoses and electrical cables with flame-resistant cover.

3. Cover platform as shown in FIG. 75-1.

4. Weld the Liftgate RH and LH columns to vehicle body as shown in FIG. 75-1.

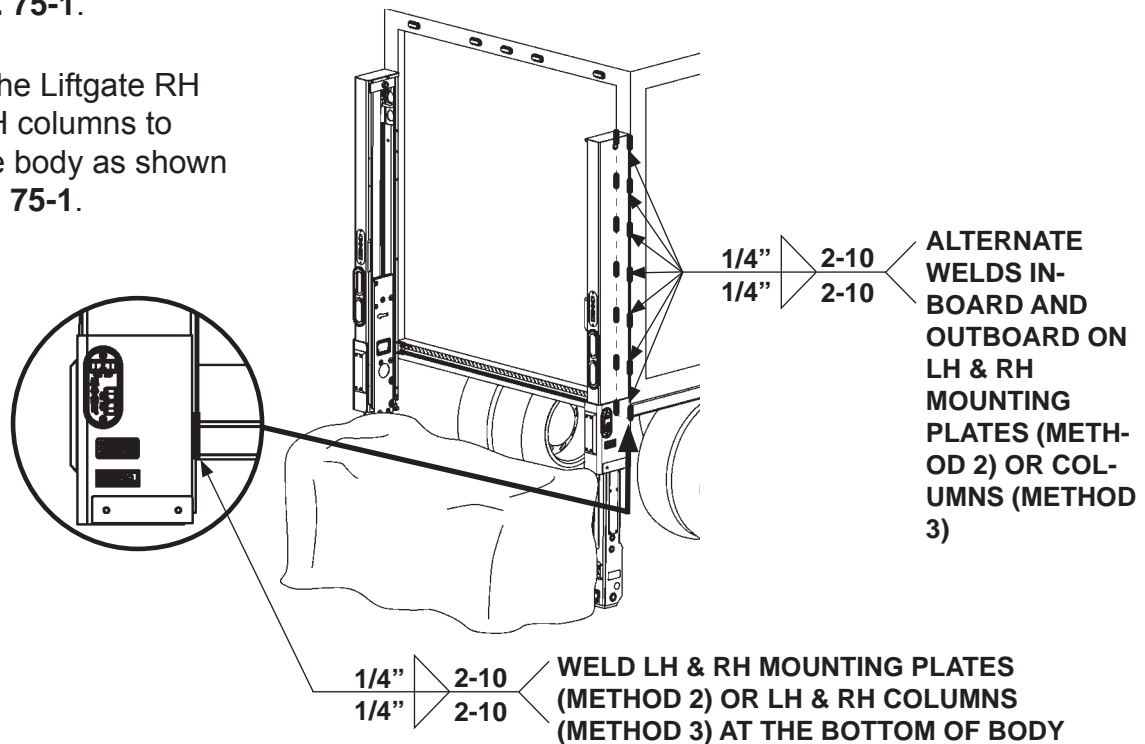

FIG. 75-1

STEP 16 - FINISH WELDING LIFTGATE TO VEHICLE METHOD 2 & METHOD 3 - WELD LIFTGATE TO BODY - Continued

CAUTION

To prevent damage to Liftgate components, welder ground must be connected to Liftgate extension plate.

5. Make sure platform is at ground level to provide access to the extension plate.

NOTE: After welding top of extension plate, if you see a gap between bottom of extension plate & vehicle body sill, fill the gap. To fill the gap, use A-36 General Purpose steel and the same welds shown in **FIG. 76-2**.

6. Weld the top and bottom surfaces of extension plate (**FIGS. 76-1 & 76-2**) to vehicle body sill.

7. Weld entire length (**FIG. 76-2**) on the bottom of LH and RH end blocks.

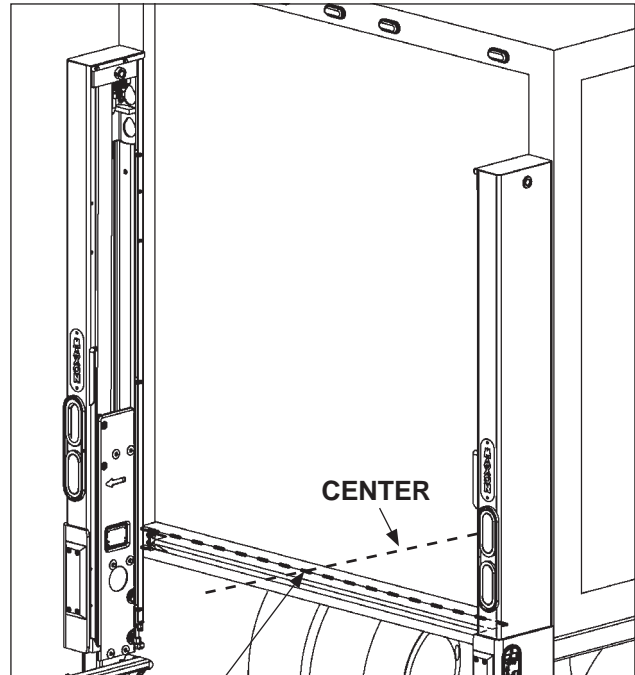

3/16" 2-5 START AT CENTER. ENDS MUST BE WELDED. TYPICAL - 17 WELDS.

**WELDING TOP OF EXTENSION PLATE
FIG. 76-1**

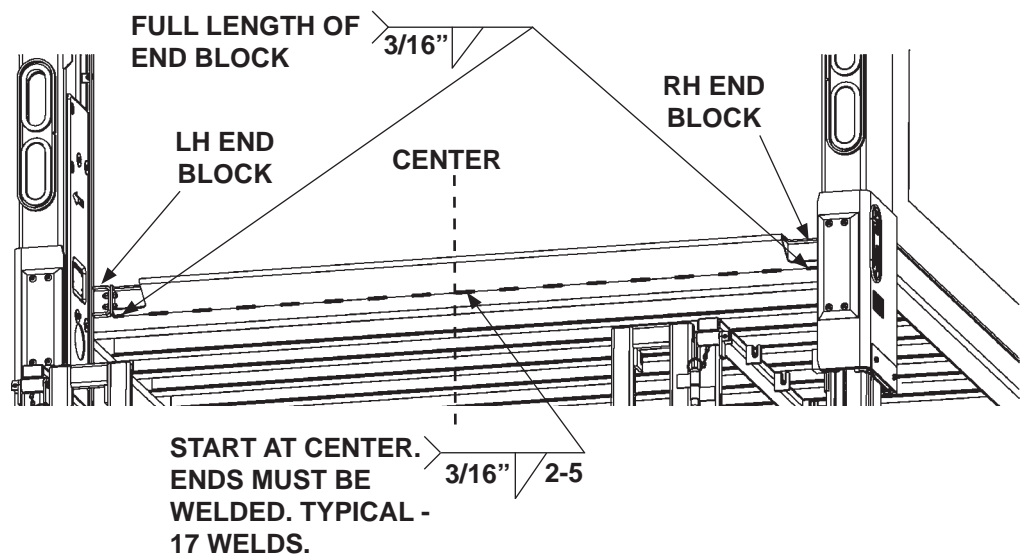

START AT CENTER. ENDS MUST BE WELDED. TYPICAL - 17 WELDS. 3/16" 2-5

**WELDING BOTTOM OF EXTENSION PLATE
FIG. 76-2**

STEP 16 - FINISH WELDING LIFTGATE TO VEHICLE METHOD 2 & METHOD 3 - WELD LIFTGATE TO BODY - Continued

8. Reconnect power to the pump by reconnecting positive (+) and negative (-) cables to battery (FIG. 77-1). Reinstall and tighten nut when each battery cable is reconnected.

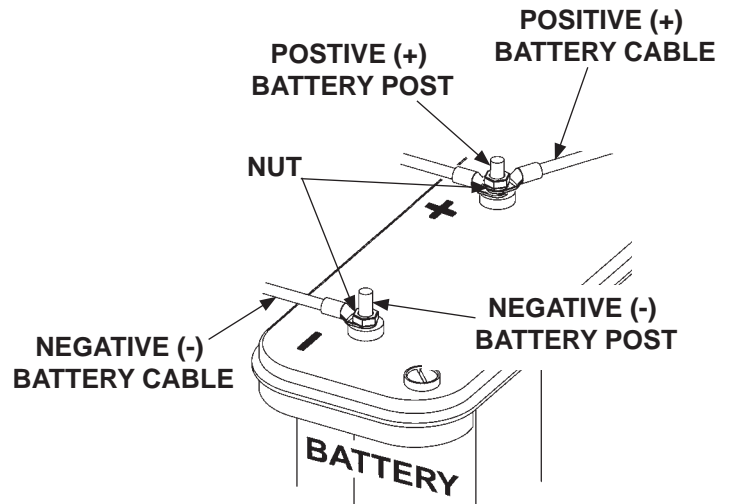

**BATTERY POWER RECONNECTED
FIG. 77-1**

STEP 17 - CHECK CLEARANCE OF CONNECTOR BAR SIDE BRACKETS & STOP BLOCKS

1. To check for interference between platform connector bar side bracket and stop block (**FIG. 78-1A**), lower columns to approximately 10" above the ground, then begin to unfold platform (**FIG. 78-1**).
2. As platform is unfolding, check for interference from the connector bar side bracket as it slides into the stop block (**FIG. 78-1A**).

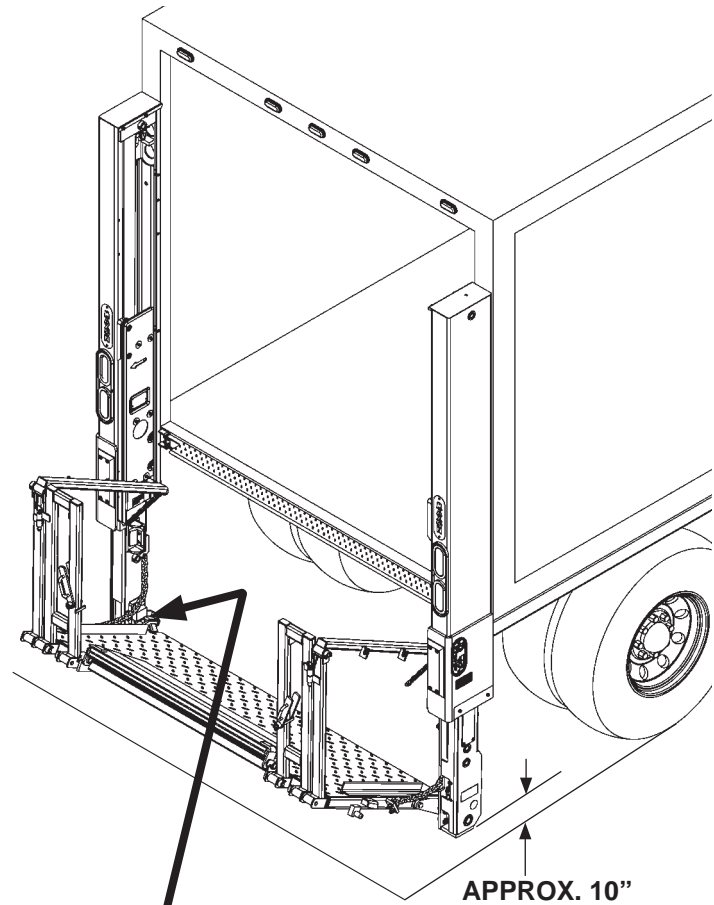
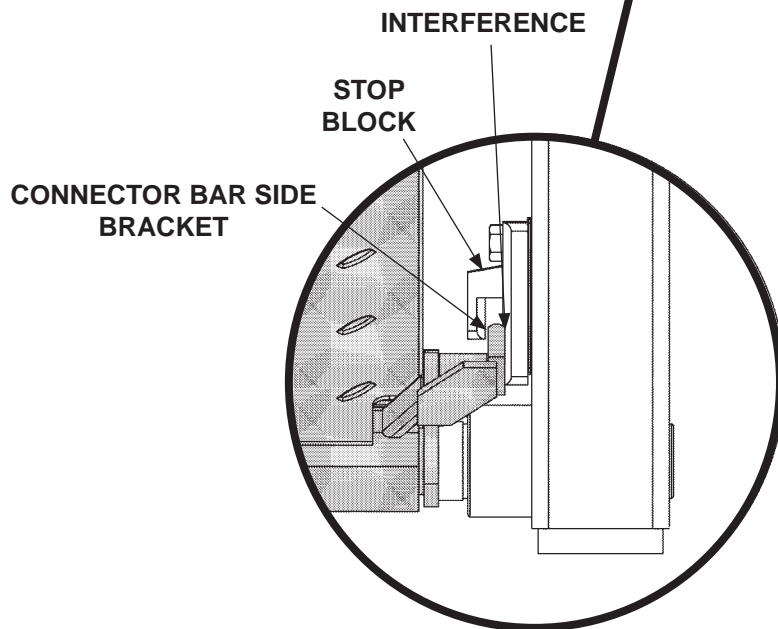

FIG. 78-1



REAR VIEW OF LH RUNNER
FIG. 78-1A

STEP 17 - CHECK CLEARANCE OF CONNECTOR BAR SIDE BRACKETS & STOP BLOCKS - Continued

NOTE: Perform this step only if folding operation is not smooth or there is interference.

3. If LH side bracket fits too tight against either side of stop block, operation is not smooth, or if there is interference (**FIG. 79-1A**) adjust with spacers as shown in **FIG. 79-1A**.
4. To adjust stop block, make sure platform is lowered to the ground (**FIG. 79-1**). Then, loosen (4) bolts (**FIGS. 79-1A and 79-1B**) and check gap (**FIG. 79-1A**). Add or remove shims (parts box) to fill or lessen the gap, then retighten bolts (**FIGS. 79-1A and 79-1B**).

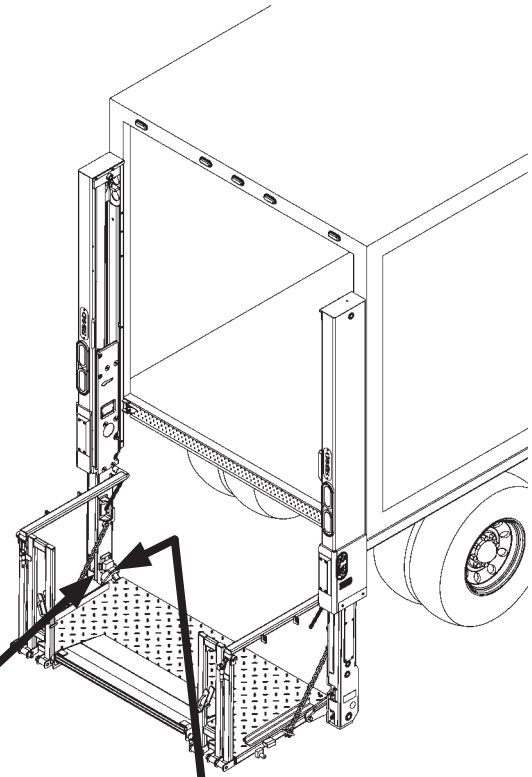
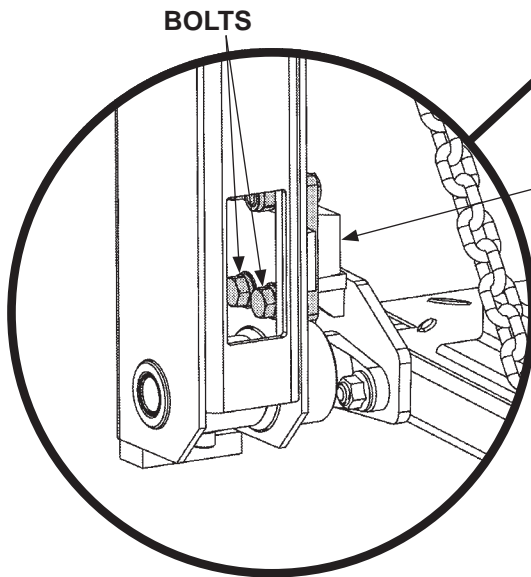
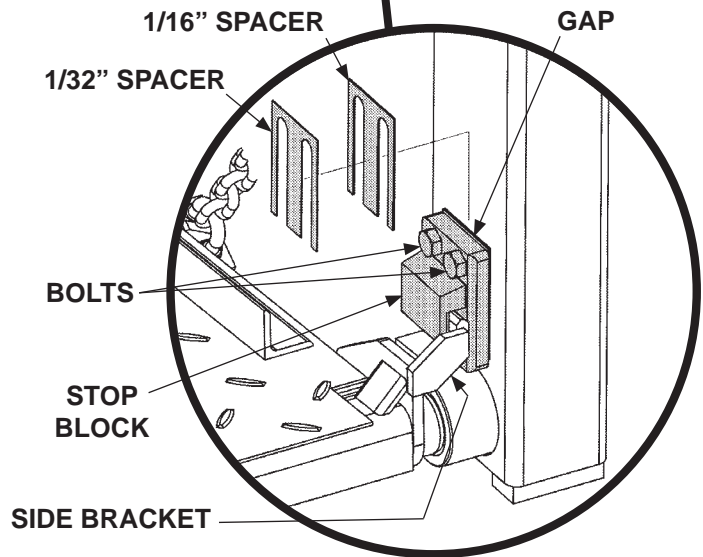

FIG. 79-1



**FRONT VIEW OF LH RUNNER
FIG. 79-1B**



**REAR VIEW OF LH RUNNER
FIG. 79-1A**

MAXON® 11921 Slauson Ave. Santa Fe Springs, CA. 90670 (800) 227-4116 FAX (888) 771-7713

STEP 18 - CHECK CLEARANCE OF RUNNER PADS

NOTE: Perform the following steps with no load on the platform.

1. Raise the platform to bed height (**FIG. 80-1**). Then, lower the platform to the ground (**FIG. 80-2**). Look for the following conditions:

- Platform lowers smoothly.
- Platform lowers evenly on both sides.
- Platform lowers in **8 to 20 seconds** (**BMR-CS35/BMR-CS44**).

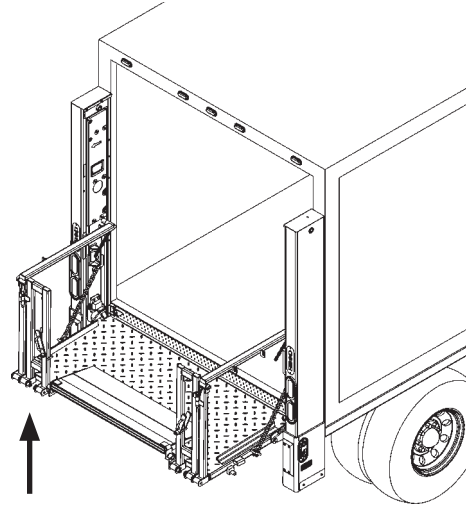

**PLATFORM AT BED HEIGHT
FIG. 80-1**

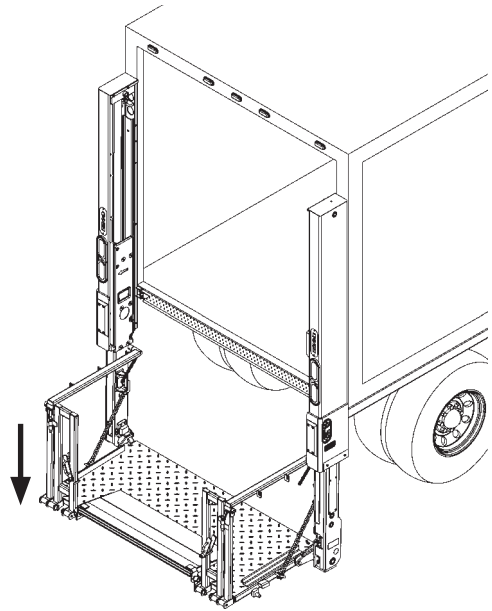

**PLATFORM ON THE GROUND
FIG. 80-2**

STEP 18 - CHECK CLEARANCE OF RUNNER PADS - Continued

2. Raise the platform to bed height (FIG. 81-1). Check clearance of the runner pads as follows:

- Between upper runner pad and inner LH column.
- Between bottom runner pad and inner LH column.
- Between upper runner pad and inner RH column.
- Between bottom runner pad and inner RH column.

Sufficient clearance is equal to thickness of **2 business cards** or **.012" to .025"** measured with thickness gauge. Leaves of the thickness gauge should be 3" or longer to reach the runner pads.

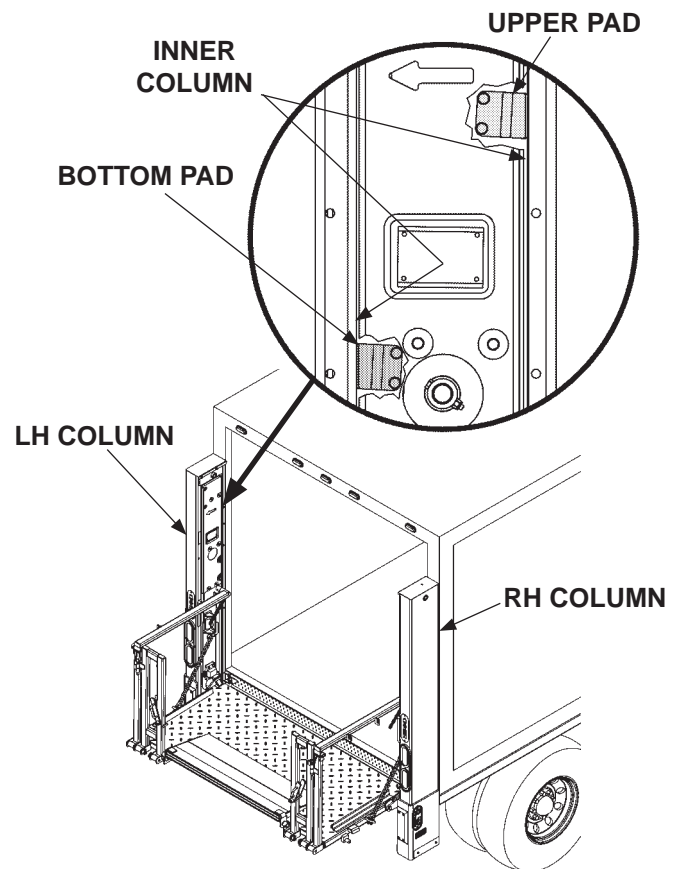

**CHECKING CLEARANCE OF RUNNER PADS
WITH PLATFORM AT BED HEIGHT
FIG. 81-1**

3. Lower the platform half the distance to the ground (FIG. 81-2). Repeat the clearance checks in 2.

4. If there is no clearance or clearance is not sufficient, continue with adjustment procedure on the next page.

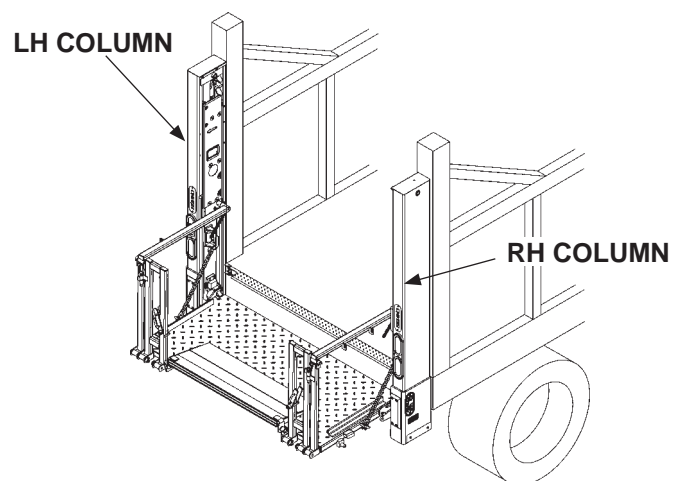

**CHECKING CLEARANCE OF RUNNER PADS
WITH PLATFORM BETWEEN BED
HEIGHT & THE GROUND
FIG. 81-2**

STEP 18 - CHECK CLEARANCE OF RUNNER PADS - Continued

5. Remove LH runner cover (FIG. 82-1).

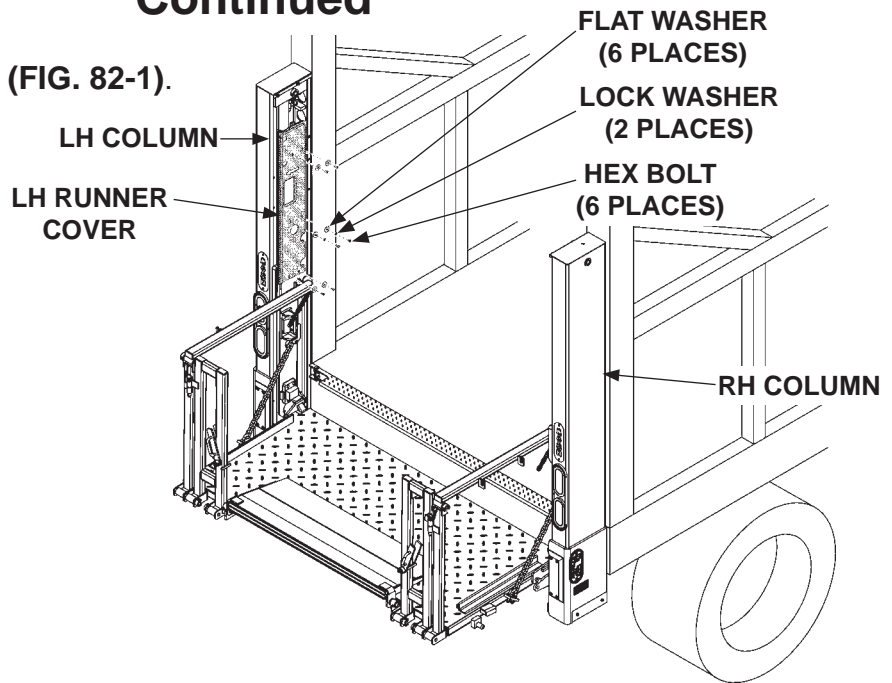

**REMOVING RUNNER COVERS
FIG. 82-1**

NOTE: Keep spacer pad in place between column & runner after unbolting pad from runner.

6. Unbolt bottom spacer pad from LH runner (FIG. 82-2). Keep bolts and lock washers to reinstall.

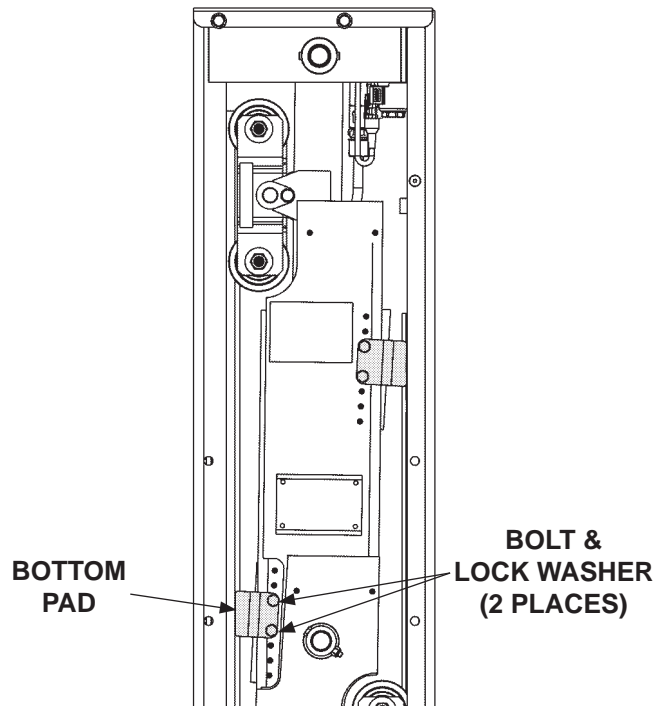

**UNBOLTING PADS
(LH COLUMN & RUNNER SHOWN)
FIG. 82-2**

STEP 18 - CHECK CLEARANCE OF RUNNER PADS - Continued

7. Ensure the bottom tandem rollers are seated against inner column (**FIG. 83-1**). Next, slide the bottom pad down against wedge until there is no clearance between inner column and bottom pad (**FIG. 83-1**). Then, back off (slide up) bottom pad by 1 hole position to create clearance between pad and inner column.
8. Bolt bottom pad to LH runner with 2 bolts and 2 lock washers (**FIG. 83-2**). Torque the 2 bolts to **9-14 lb-ft**.

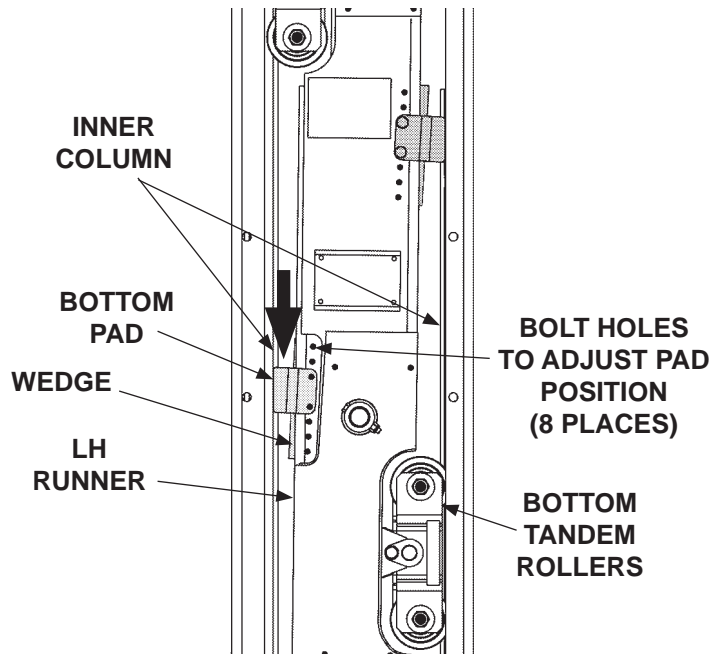

**ADJUSTING LOWER PAD
FIG. 83-1**

NOTE: Keep spacer pad in place between column & runner after unbolting pad from runner.

9. Unbolt upper spacer pad from LH runner (**FIG. 83-2**). Keep bolts & lock washers to reinstall.

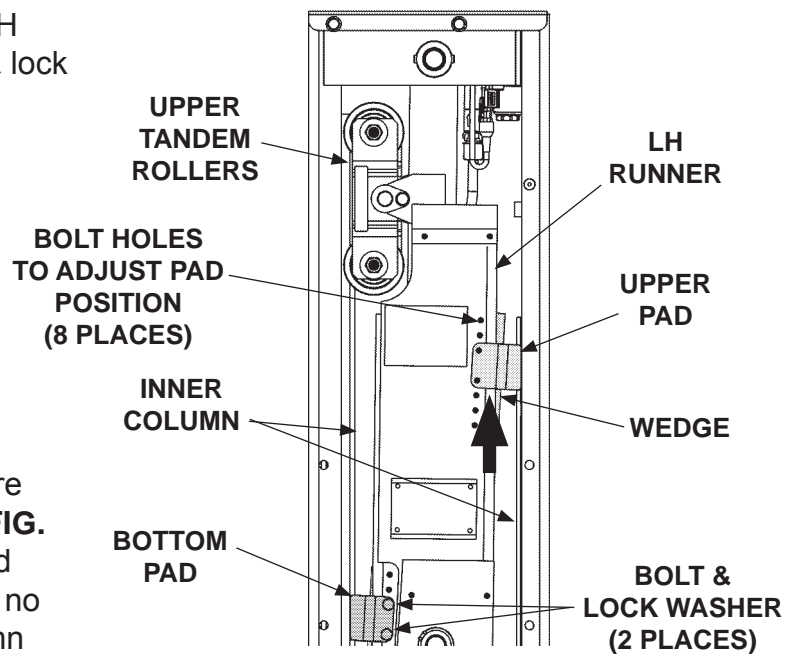

**BOLTING LOWER PAD &
ADJUSTING UPPER PAD
FIG. 83-2**

10. Ensure upper tandem rollers are seated against inner column (**FIG. 83-2**). Next, slide the upper pad up against wedge until there is no clearance between inner column and upper pad (**FIG. 83-1**). Then, back off (slide down) lower pad by 1 hole position to create clearance between upper pad and inner column.

STEP 18 - CHECK CLEARANCE OF RUNNER PADS - Continued

11. Bolt upper pad to LH runner with 2 bolts and 2 lock washers (**FIG. 84-1**). Torque the 2 bolts to **9-14 lb-ft.**

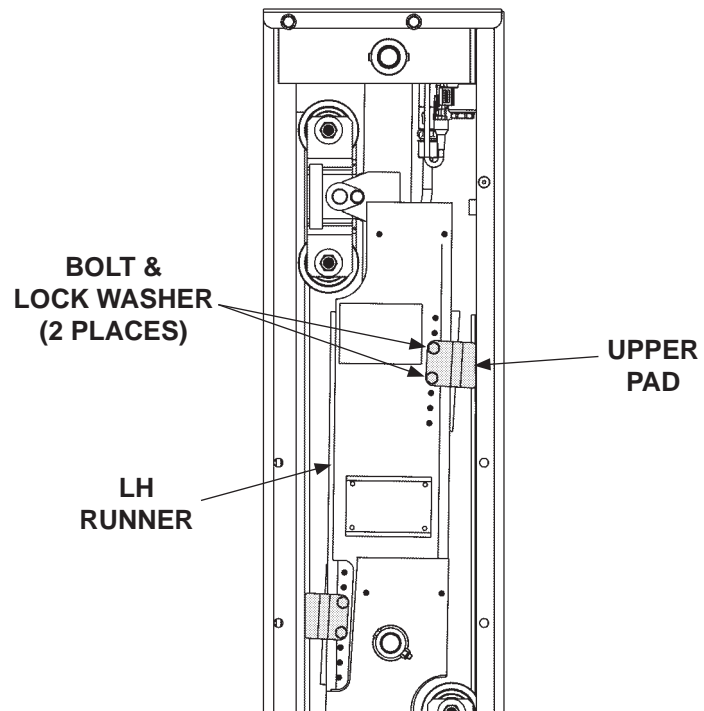

**BOLTING UPPER PAD
FIG. 84-1**

12. Repeat instructions 5 to 11 for RH column.

13. Raise the platform to bed height (**FIG. 84-2**). Then, lower the platform to the ground (**FIG. 84-2**). Look for the following conditions:

- Platform lowers smoothly.
- Platform lowers evenly on both sides.
- Platform lowers in **8 to 20 seconds** (**BMR-CS35/BMR-CS44**).

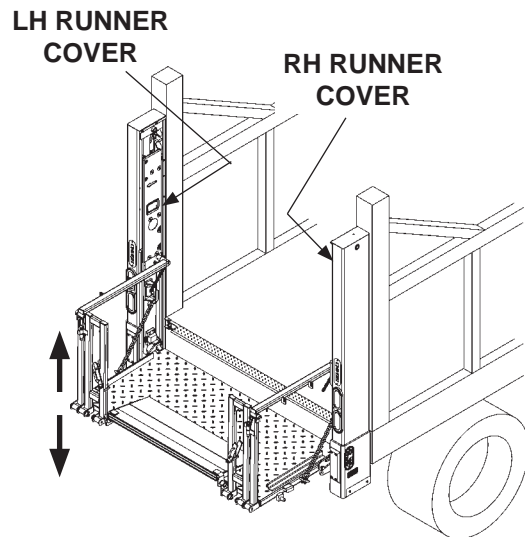

**CHECKING CLEARANCE OF RUNNER PADS
WITH PLATFORM BETWEEN BED
HEIGHT & THE GROUND
FIG. 84-2**

14. When platform raises and lowers correctly, reinstall LH and RH runner covers (**FIG. 84-2**). Torque 6 bolts on each runner cover to **9-14 lb.-ft.**

STEP 19 - PLATFORM CHAIN ADJUSTMENT

1. Lower the platform to ground level. Check if tip of the platform and bottom of the runners touch the ground at the same time (**FIG. 85-1**).

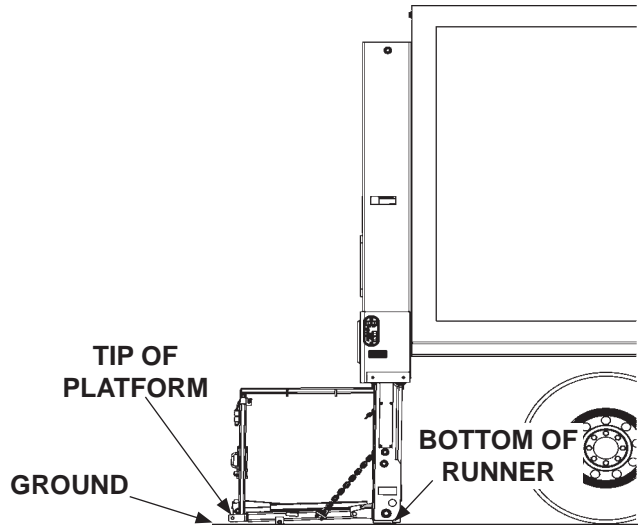

**TIP AND RUNNER TOUCHING GROUND
FIG. 85-1**

2. If tip of platform touches first, tighten the u-bolt by loosening the hex nuts and turning the lock nuts clockwise (**FIG.85-2A**). Retighten hex nuts. If more adjustment is required, remove one chain link until tip of the platform and bottom of the runners touch the ground at the same time (**FIG.85-2**).

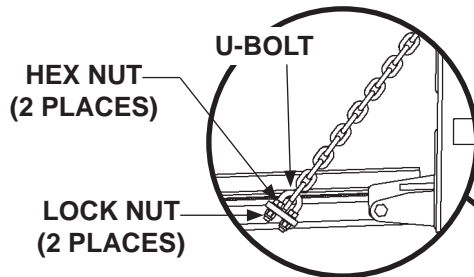
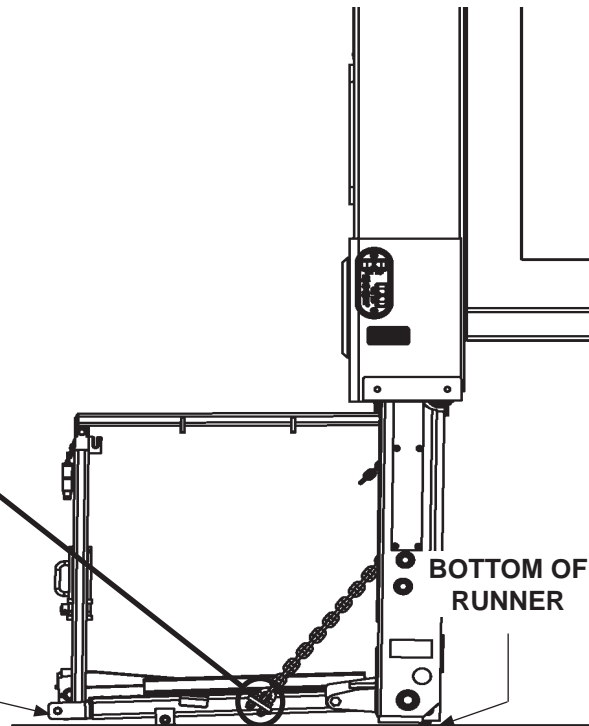

FIG. 85-2A

**TIP OF
PLATFORM**



**PLATFORM LOWERED TO
GROUND
FIG. 85-2**

STEP 20 - PLACE "ALIGN ARROWS" DECAL

NOTE: Make sure **RUNNERS** are raised all the way up (closest to top of **COLUMN**) before doing the following steps.

Peel backing from alignment tape and place it on LH column as shown in **FIG. 86-1**. Repeat for RH column.

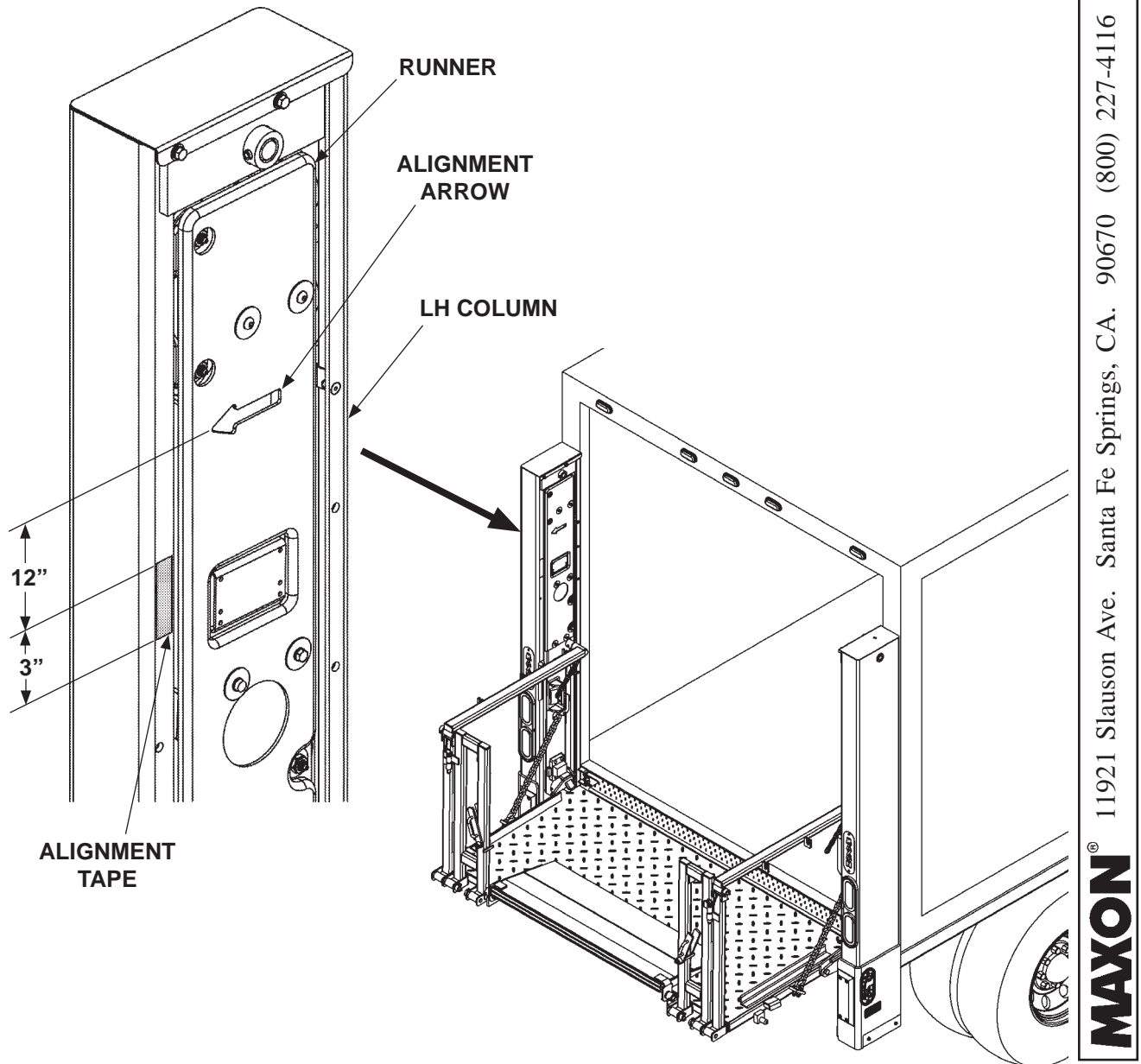

FIG. 86-1

DECALS & PLATES

NOTE: Ensure there is no residue, dirt, or corrosion where decals are attached. If necessary, clean surface before attaching decals.

NOTE: Decals on the Liftgate are attached at the factory.

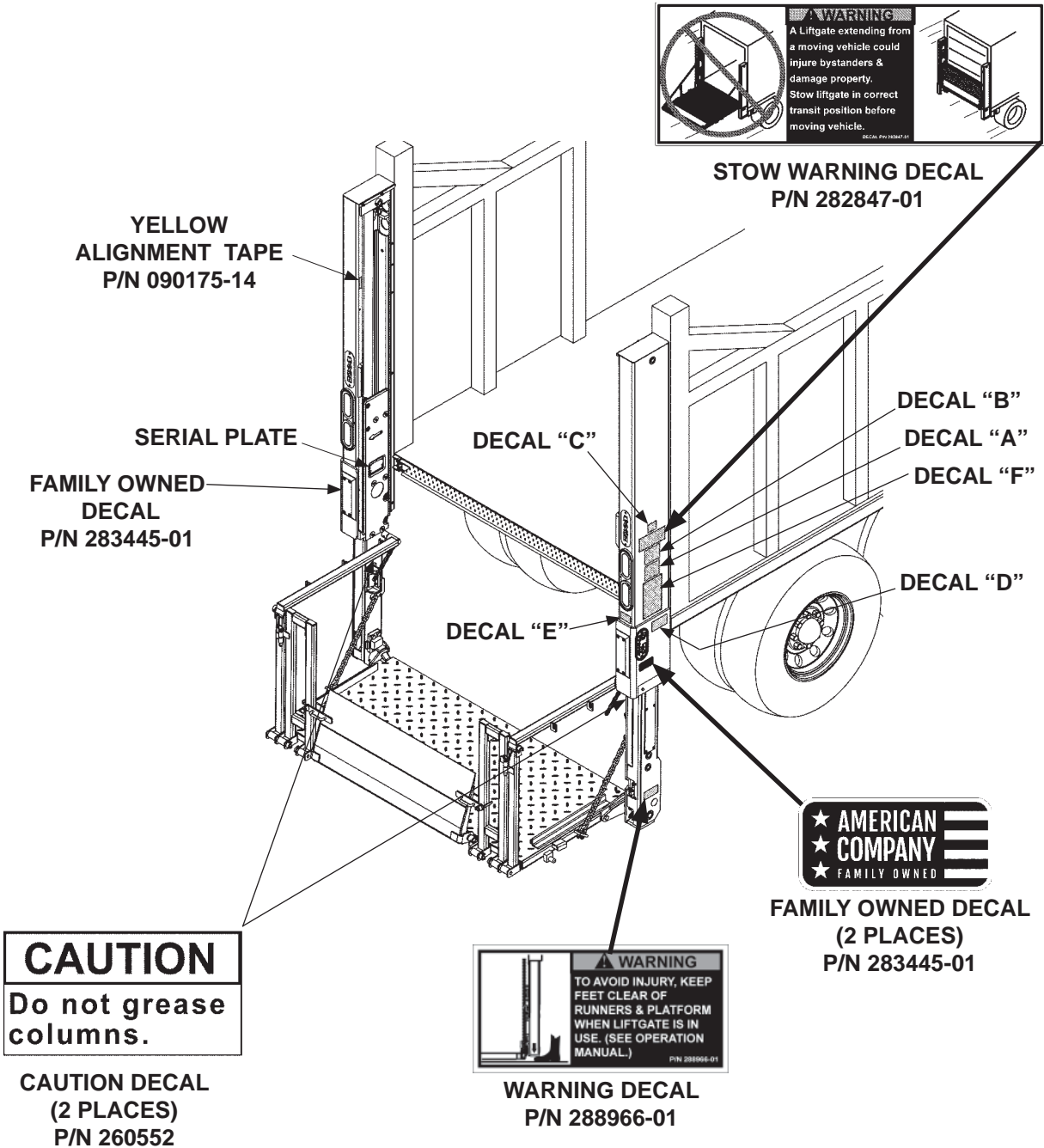

FIG. 87-1

DECALS - Continued

⚠ WARNING
Read this information carefully.

- Improper operation of this Liftgate can result in serious personal injury. If you do not have a copy of the operating instructions, please obtain them from your employer, distributor, or lessor before you attempt to operate Liftgate.
- If there are signs of improper maintenance, damage to vital parts, or slippery platform surface, do not use the Liftgate until these problems have been corrected.
- If you are using a pallet jack, be sure it can be maneuvered safely.
- Do not operate a forklift on the platform.
- Do not allow any part of yours or your helper's body to be placed under, within, or around any portion of the moving Liftgate, or its mechanisms, or in a position that would trap them between the platform and the ground or truck when the Liftgate is operated.
- If a helper is riding the platform with you, make sure you are both doing so safely and that you are not in danger of coming in contact with any moving or potentially moving obstacles.
- **USE GOOD COMMON SENSE.**
- If load appears to be unsafe, do not lift or lower it.

For a free copy of other manuals that pertain to this model Liftgate, please visit our website at www.maxonlift.com or call Customer Service at (800) 227-4116. **B**

SAFETY INSTRUCTIONS
 Read all decals and operation manual before operating liftgate.

1. Do not use liftgate unless you have been properly instructed and have read, and are familiar with, the operating instructions.
2. Be certain vehicle is properly and securely braked before using the liftgate.
3. Always inspect this liftgate for maintenance or damage before using it. Do not use liftgate if it shows any sign of damage or improper maintenance.
4. Do not overload
5. Make certain the area in which the platform will open and close is clear before opening or closing the platform.
6. Make certain platform area, including the area in which loads may fall from platform, is clear before and at all times during operation of liftgate.
7. This liftgate is intended for loading and unloading of cargo only. Do not use this liftgate for anything but its intended use.

A

THE MAXIMUM CAPACITY OF THIS LIFT IS

___ LB [___ KG]

WHEN THE LOAD IS CENTERED ON THE LOAD CARRYING PLATFORM

C

(REFER TO TABLE 88-1)

⚠ CAUTION
 Always stand clear of platform area.

E

⚠ WARNING
 Liftgate hazards can result in crushing or falling.
 Keep hands and feet clear of pinch points.
 If riding liftgate, make sure load is stable and footing is solid.

D

Read and understand all instructions and WARNINGS before use.

OPERATING INSTRUCTIONS

OPERATE	STOW
<p>1 LOWER RUNNERS TO LINE UP YELLOW ARROW WITH YELLOW STRIPE. THIS SHOWS PLATFORM IS CLEAR TO UNFOLD.</p>	<p>1 RAISE PLATFORM TO LINE UP YELLOW ARROW WITH YELLOW STRIPE. THIS SHOWS PLATFORM IS CLEAR TO FOLD.</p>
<p>2 UNFOLD PLATFORM.</p>	<p>2 FOLD PLATFORM.</p>
<p>3 - LOWER PLATFORM. IF IT IS SLOW TO LOWER & LIFTGATE IS POWER DOWN EQUIPPED, PUSH POWER DOWN BUTTON. 2 - RAISE PLATFORM. POWER DOWN BUTTON (IF EQUIPPED).</p>	<p>3 RAISE RUNNERS TO STOW PLATFORM.</p>

PIN 289163-01 **F**

DECAL SHEET
 FIG. 88-1

MODEL	ORDER P/N	DECAL "C"
BMR-CS35	289163-01	3500 LBS. [1600 KG]
BMR-CS44	289163-02	4400 LBS. [2000 KG]

DECAL SHEET PART NUMBERS
 TABLE 88-1

11921 Slauson Ave. Santa Fe Springs, CA. 90670 (800) 227-4116 FAX (888) 771-7713

MAXON

TOUCH UP GALVANIZED FINISH

CAUTION

Damaged cylinder seals and contaminated hydraulic fluid can result from applying cold galvanized spray to the polished portion of the cylinder rod. To prevent damage, protect the exposed polished portion of the cylinder rod while spraying.

- If bare metal is exposed on galvanized portions of the Liftgate, touch up the galvanized finish. To maintain the protection provided by the original galvanized finish, **MAXON** recommends cold galvanize spray.

HYDRAULIC SYSTEM DIAGRAMS

PUMP & MOTOR SOLENOID OPERATION - POWER DOWN

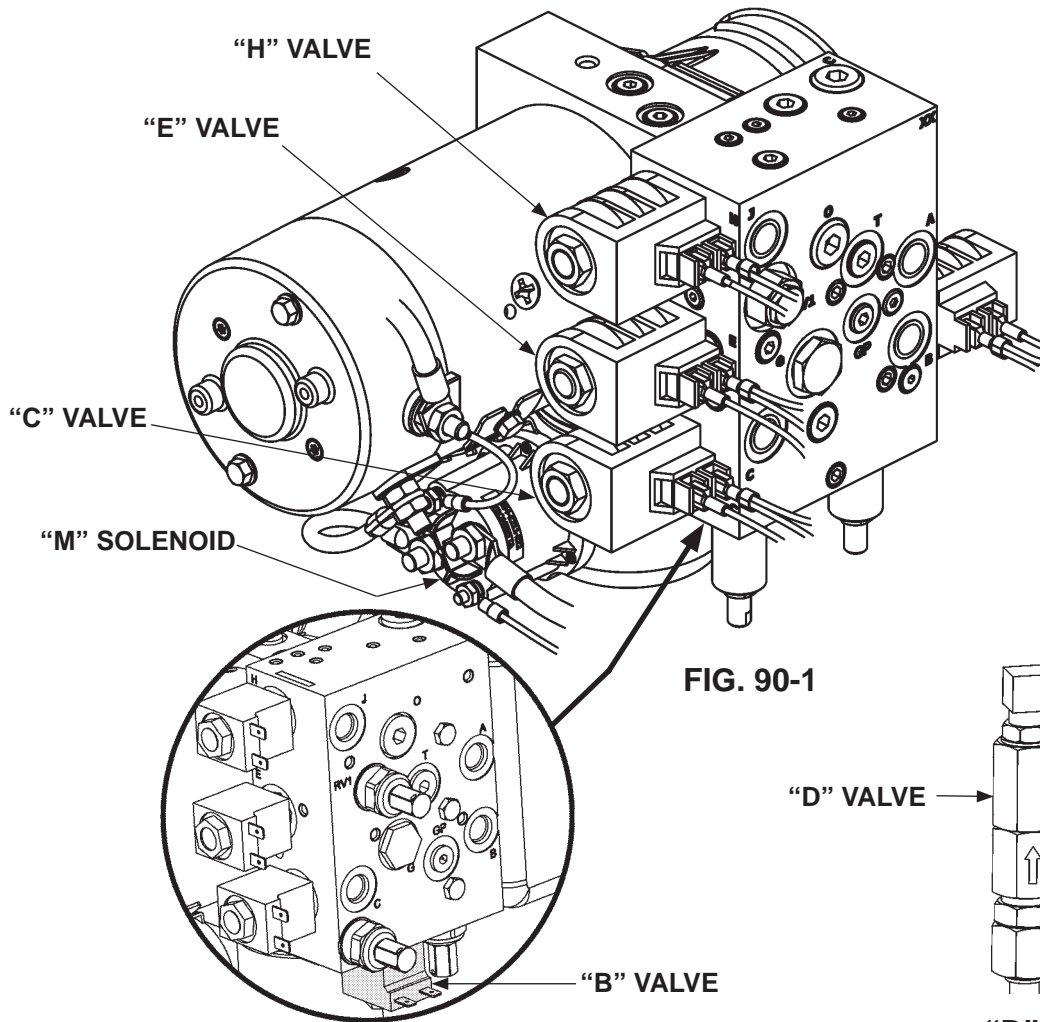

FIG. 90-1

BUCHER PUMP "B" VALVE
FIG. 90-2

"D" VALVES
(TOP OF EACH COLUMN)
FIG. 90-3

POWER UNIT MOTOR & SOLENOID OPERATION - POWER DOWN									
LIFTGATE FUNCTION	PORT	SOLENOID OPERATION (✓ MEANS ENERGIZED)							
		SWITCH	RELAY	MOTOR	VALVE "B"	VALVE "C"	VALVE "D"	VALVE "E"	VALVE "H"
LIFT	B	"PD"	-	✓	-	-	-	-	-
LOWER	C		-	✓	✓	✓	✓	-	-
OPEN	J		-	✓	-	-	-	✓	✓
CLOSE	A		-	✓	-	-	-	✓	-
REFER TO VALVES SHOWN ON HYDRAULIC SCHEMATIC									

TABLE 90-1

HYDRAULIC SYSTEM DIAGRAMS

PUMP & MOTOR SOLENOID OPERATION - GRAVITY DOWN

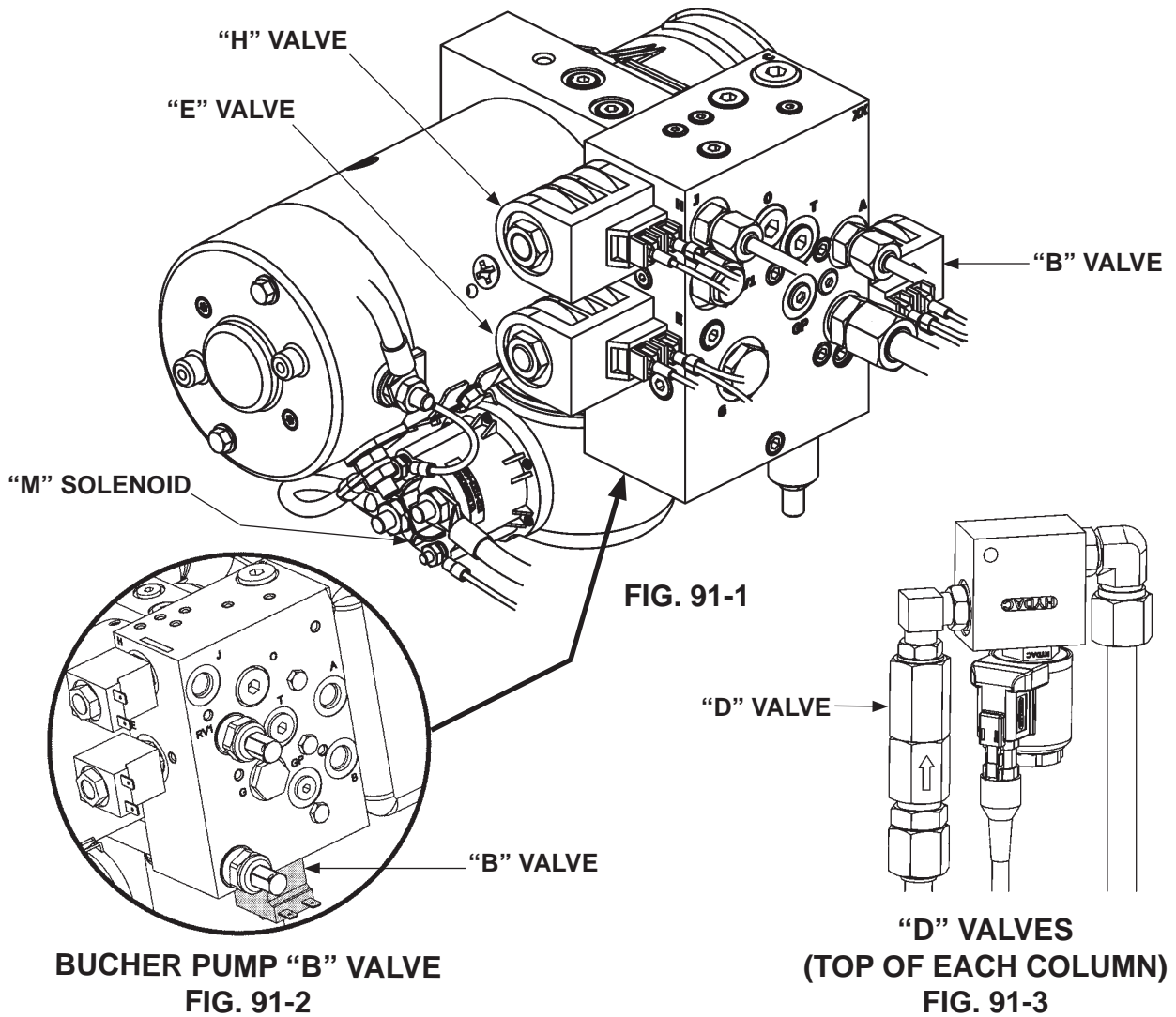

POWER UNIT MOTOR & SOLENOID OPERATION - GRAVITY DOWN								
LIFTGATE FUNCTION	PORT	SOLENOID OPERATION (✓ MEANS ENERGIZED)						
		SWITCH	RELAY	MOTOR	VALVE "B"	VALVE "D"	VALVE "E"	VALVE "H"
LIFT	B	"GD"	-	✓	-	-	-	-
LOWER	C		✓	-	✓	✓	-	-
OPEN	J		-	✓	-	-	✓	✓
CLOSE	A		-	✓	-	-	✓	-
REFER TO VALVES SHOWN ON HYDRAULIC SCHEMATIC								

TABLE 91-1

HYDRAULIC SYSTEM DIAGRAMS

GRAVITY DOWN HYDRAULIC SCHEMATIC

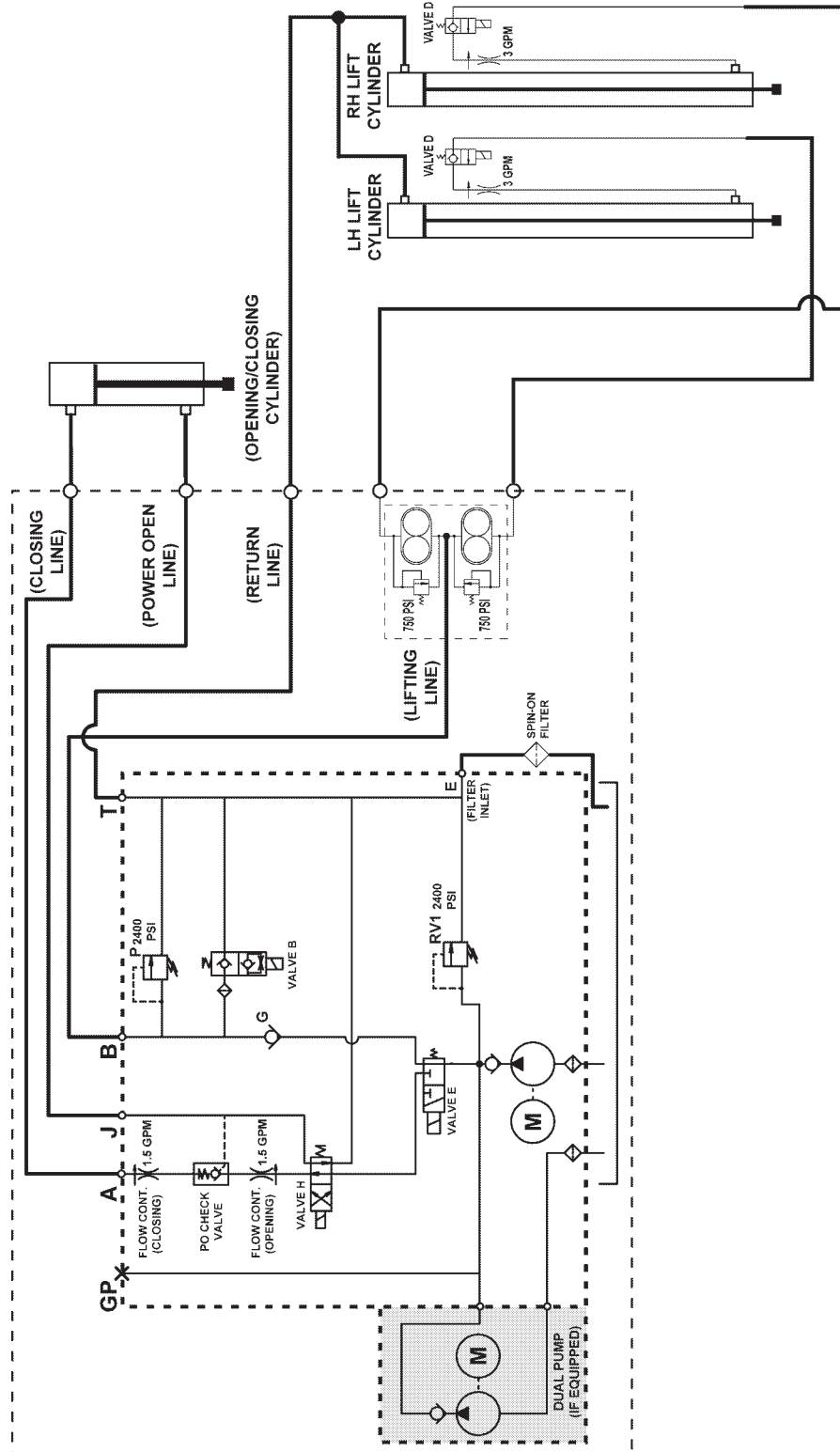

FIG. 92-1

HYDRAULIC SYSTEM DIAGRAMS

POWER DOWN HYDRAULIC SCHEMATIC

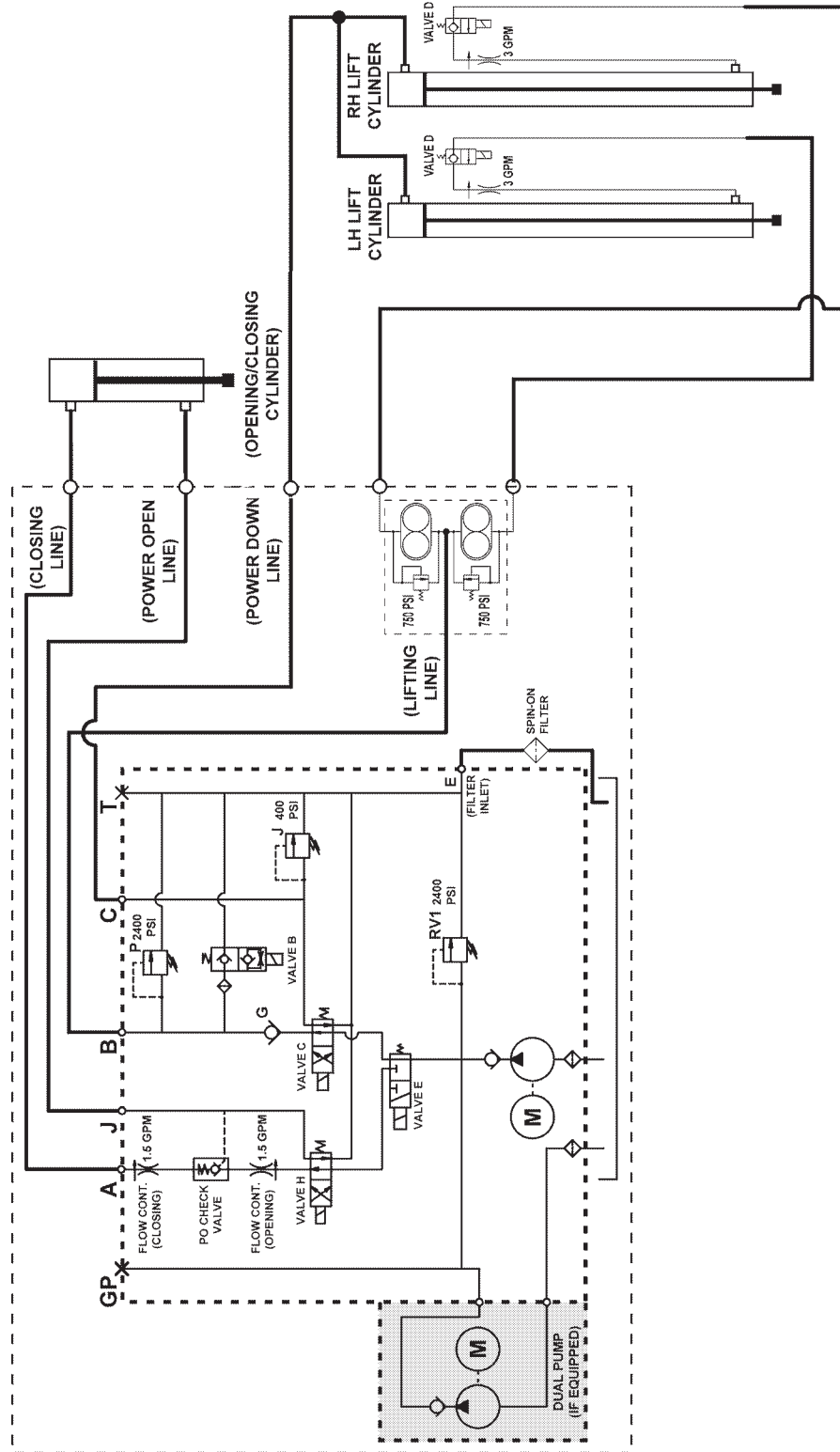

FIG. 93-1

ELECTRICAL SYSTEM DIAGRAMS

INTERCONNECTING ELECTRICAL SCHEMATIC - GRAVITY DOWN

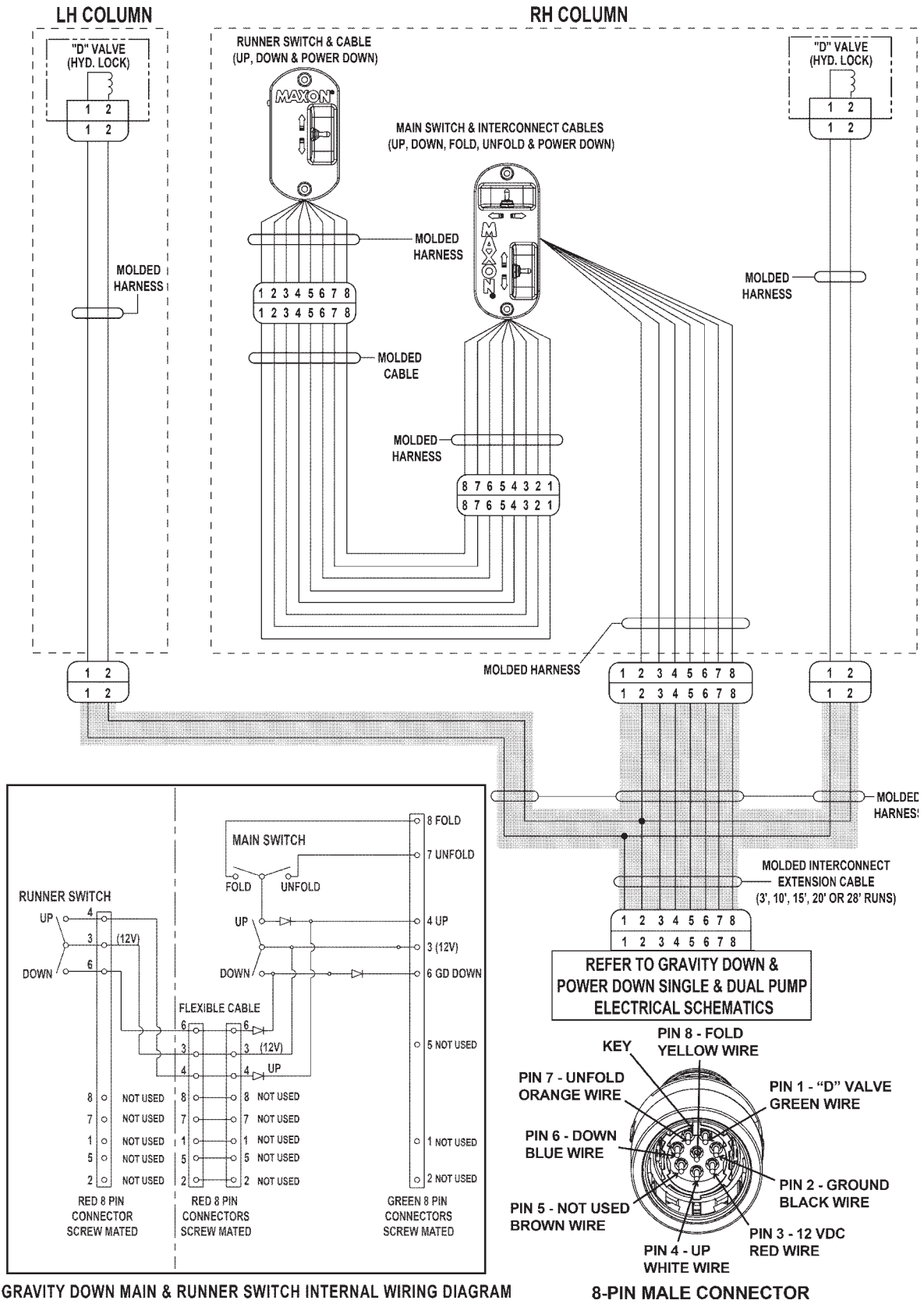

FIG. 94-1

ELECTRICAL SYSTEM DIAGRAMS

GRAVITY DOWN SINGLE & DUAL PUMP ELECTRICAL SCHEMATIC

NOTE: Refer to **BMR-CS ELECTRICAL VALUES** page.

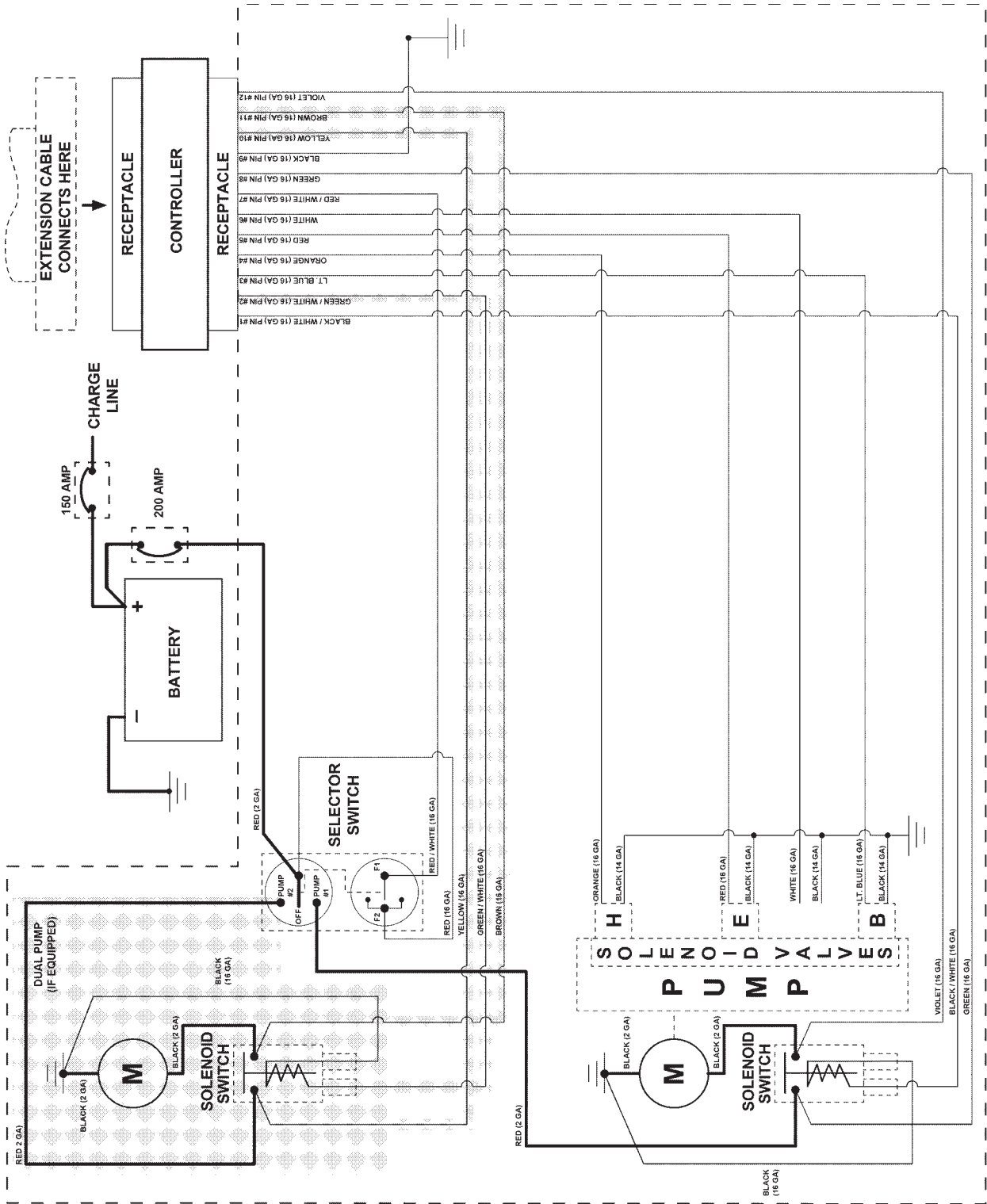

FIG. 95-1

ELECTRICAL SYSTEM DIAGRAMS - Continued INTERCONNECTING ELECTRICAL SCHEMATIC - POWER DOWN

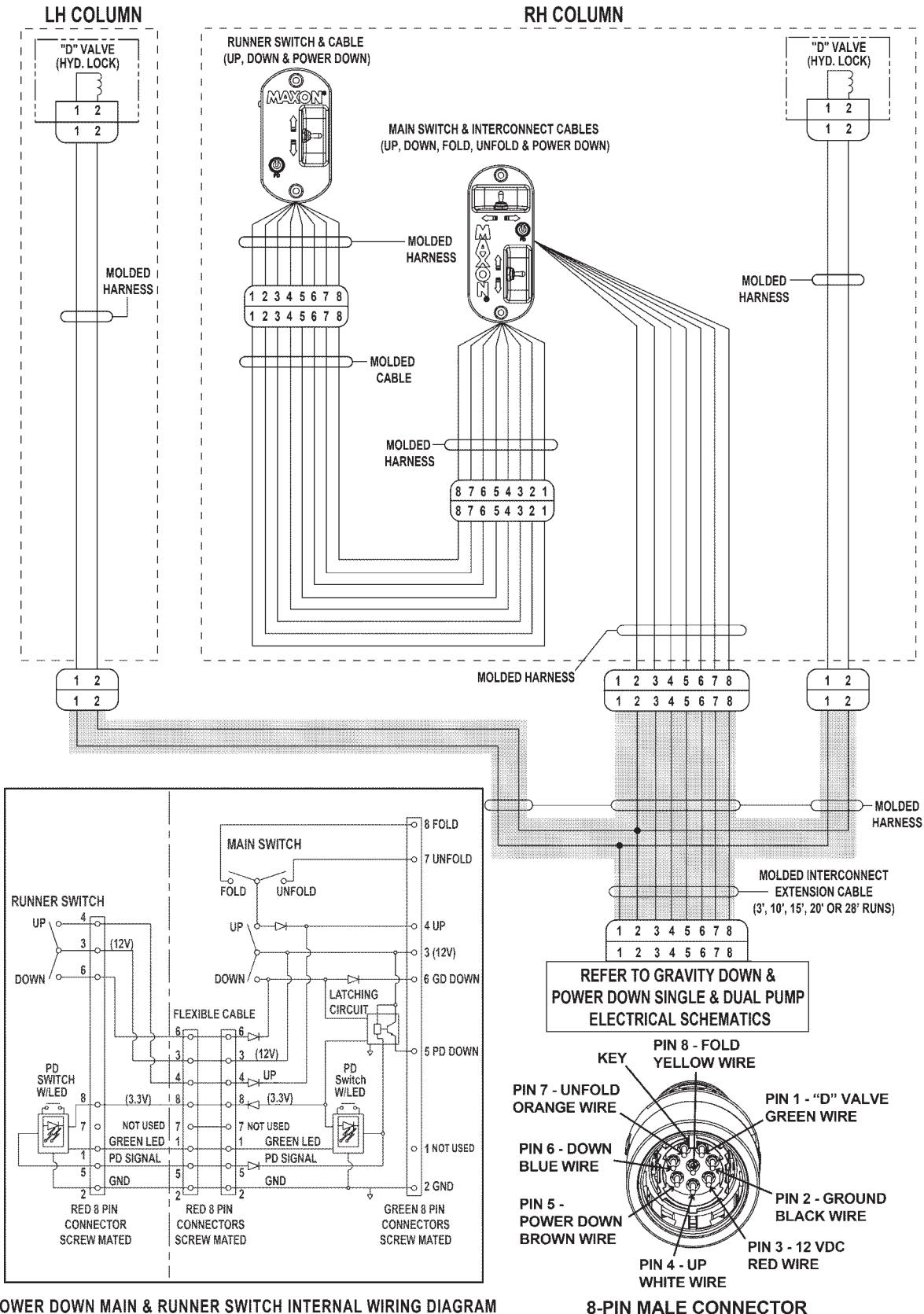

FIG. 96-1

ELECTRICAL SYSTEM DIAGRAMS

POWER DOWN SINGLE & DUAL PUMP ELECTRICAL SCHEMATIC

NOTE: Refer to **BMR-CS ELECTRICAL VALUES** page.

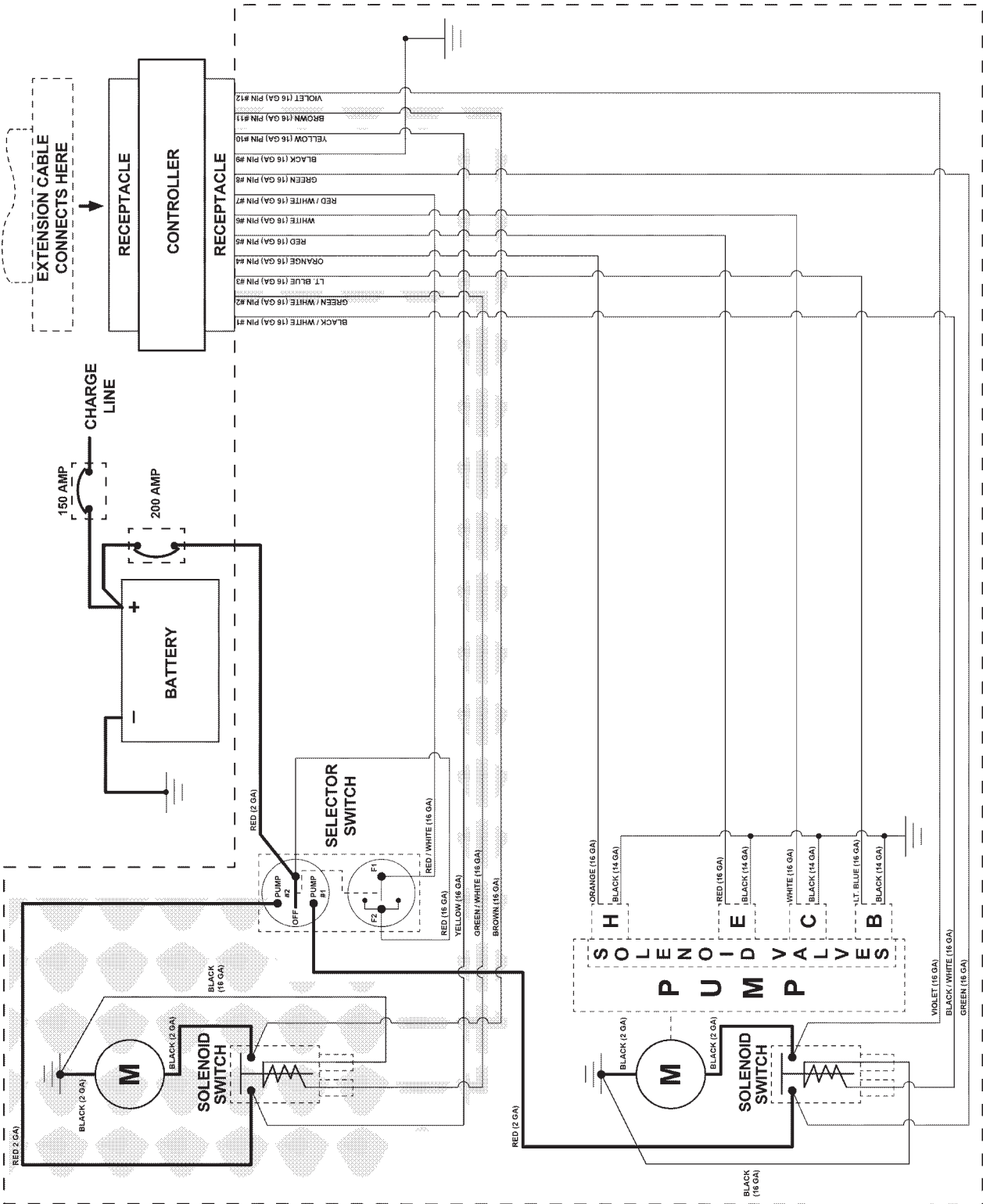

FIG. 97-1

ELECTRICAL SYSTEM DIAGRAMS

BMR ELECTRICAL VALUES

MTE PUMP	BUCHER PUMP
Solenoid Switch: <ul style="list-style-type: none"> • Coil: 5.4Ω @ 70°F. ±15% • Ampere: 2.2A @ 12V • Coil terminal torque: 10-15 lb-in • Contact terminal torque: 30-35 lb-in 	Solenoid Switch: <ul style="list-style-type: none"> • Coil: 5.4Ω @ 70°F. ±15% • Ampere: 2.2A @ 12V • Coil terminal torque: 10-15 lb-in • Contact terminal torque: 30-35 lb-in
Solenoid Valves (H, E, and C): <ul style="list-style-type: none"> • Coil: 6.6Ω @ 70°F. ±15% • Ampere: 1.8A @ 12V • Coil nut torque: 15-45 lb-in 	Solenoid Valves (H, E, and C): <ul style="list-style-type: none"> • Coil: 4.0Ω @ 70°F. ±15% • Ampere: 2.5A @ 10V • Coil nut torque: 15-45 lb-in
Solenoid Valve (B): <ul style="list-style-type: none"> • Coil: 7.5Ω @ 70°F. ±15% • Ampere: 1.6A @ 12V • Coil nut torque: 15-45 lb-in 	Solenoid Valve (B): <ul style="list-style-type: none"> • Coil: 4.0Ω @ 70°F. ±15% • Ampere: 2.5A @ 10V • Coil nut torque: 15-45 lb-in
H, E, C & B Valve Cartridge Torque: 25-30 lb-ft maximum <ul style="list-style-type: none"> • Coil nut torque: 15-45 lb-in 	H, E, C & B Valve Cartridge Torque: 25-30 lb-ft maximum <ul style="list-style-type: none"> • Coil nut torque: 15-45 lb-in
Solenoid Valve (D): <ul style="list-style-type: none"> • Coil: 8.0Ω @ 70°F. ±15% • Ampere: 1.5A @ 12V • Coil nut torque: 3-4.5 lb-ft • Valve cartridge torque: 18.5-22 lb-ft 	Solenoid Valve (D): <ul style="list-style-type: none"> • Coil: 8.0Ω @ 70°F. ±15% • Ampere: 1.5A @ 12V • Coil nut torque: 3-4.5 lb-ft • Valve cartridge torque: 18.5-22 lb-ft
Pump Selector Switch Terminal Stud Torque: 140 lb-in maximum	Pump Selector Switch Terminal Stud Torque: 140 lb-in maximum
Cable Ground Stud Torque: 24 lb-ft maximum	Cable Ground Stud Torque: 24 lb-ft maximum

MAXON® 11921 Slauson Ave. Santa Fe Springs, CA. 90670 (800) 227-4116 FAX (888) 771-7713

MAXON®

PRE-DELIVERY INSPECTION FORM

Model: _____

Date: _____

Serial Number: _____

Technician: _____

Pre-Installation Inspection:

- Correct model
- Correct capacity
- Correct platform size
- Correct options
- Manuals & decals

Structural Inspection:

- Inspect alignment of final assembly
- Inspect pump box secure mounting
- Inspect all installation welds
- Check roll pins, bolts and fasteners
- Check for no twists in chain
- Inspect tightness of hardware used for securing columns to mounting plates
- Ensure platform ramp touches ground

Hydraulic Inspection:

- Proper fluid level (See OPTIMIZE HYDRAULIC FLUID LEVEL step in this manual)
- Check fittings for leaks in pump box
- Check fittings for leaks in columns

Electrical Inspection:

- Check power/charge plug and terminal
- Check for loose wires and terminals
- Circuit breaker
- Battery hookup, 12 volt
- Ensure batteries are fully charged
- Inspect all solenoid connections
- Check all wiring harness connections
- Outside control box location
- Check electrical cable connections (at the bottom of the curb-side runner) tight and secure

Operation Inspection:

NOTE: The following times are for 56" bed height, aluminum platform and flipover, 85" W x 42" + 42" L, Exxon Univis HVI-13 oil, & temperature at 70°F. Times are for reference only and may vary for larger platforms, smaller platforms, steel platforms, or temperature changes.

All BMR-CS

- Check operation of main control
- Check operation of runner control
- Platform unfolds in 5 to 7 sec.
- Platform folds in 5 to 7 sec.
- Unloaded platform lowers in **8 to 20 sec.**
- Platform loaded with 1000 lb (plus) lowers in **8 to 12 sec.**
- Unloaded platform raises in **9 to 21 sec.**
- Platform raises and lowers evenly. Maximum 1" difference from side to side.
- Platform stores and locks securely behind both column wedges
- Check lift operation under load
- Decals in correct location and legible

