

TUK-A-WAY® SERIES

The GPTLR Series

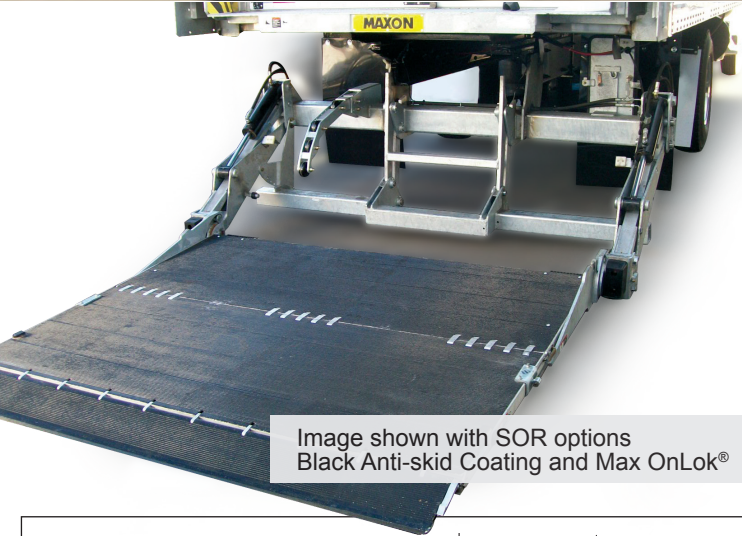

Image shown with SOR options
Black Anti-skid Coating and Max OnLok®

GPTLR SPECIFICATIONS*

The GPTLR is perfect for carts and pallets since the platform is easy to roll loads on and off. When the platform is lowered, it stays level and sits completely flat on the ground.

- Available cart stops and aluminum retention ramp help keep wheeled carts from rolling off the platform
 - Features the largest platform ever made for a Tuk-A-Way®
 - The Exclusive Load Guidance System is a unique extension plate that “guides” the load away from the edge of the platform and keeps the operator at the center
 - GPTLR offers several patent pending features
 - The GPTLR comes standard with an ICC bumper. For trailer applications the GPTLR can be equipped with an optional FMVSS or CMVSS (only available on GPTLR 44/55’s) underride
 - Platform has an improved recessed hinge
- **Galvanized Finish – STANDARD!**

* **Note:** The GPTLR is designed for dry freight body and trailer applications only. For refrigerated, flatbed or swing door applications, please contact your MAXON Sales or Customer Service Representative to find out about alternative MAXON liftgate solutions.

MODEL CAPACITY	PLATFORM SIZE**	TOTAL WEIGHT	BED HEIGHT
GPTLR-25 (2500 Lbs.)	Steel 52" X 86" 10" Fixed Ramp	1294 Lbs.	44" Min. with Body Laden 55" Max. with Body Unladen
GPTLR-33 (3300 Lbs.)	Aluminum 60" X 86" 10" Fixed Ramp		
GPTLR-44 (4400 Lbs.)	Aluminum 68" X 86" 10" Aluminum Retention Ramp	1459 Lbs.	
GPTLR-55 (5500 Lbs.)			

** Dimension shown for 102" wide vehicles

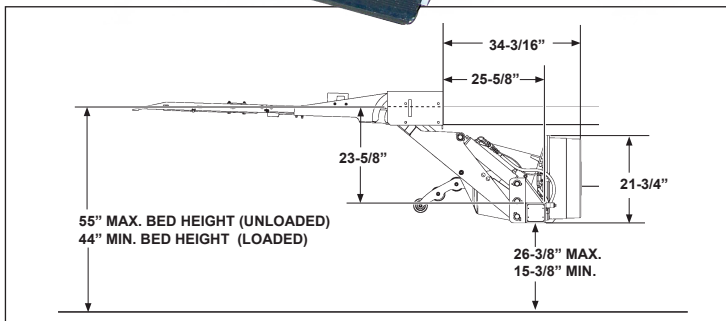

GPTLR-25 & 33 Lift Dimensions and Mounting Requirements

NOTE: Please review appropriate liftgate installation manual for full vehicle and or body requirements to ensure proper fitment.

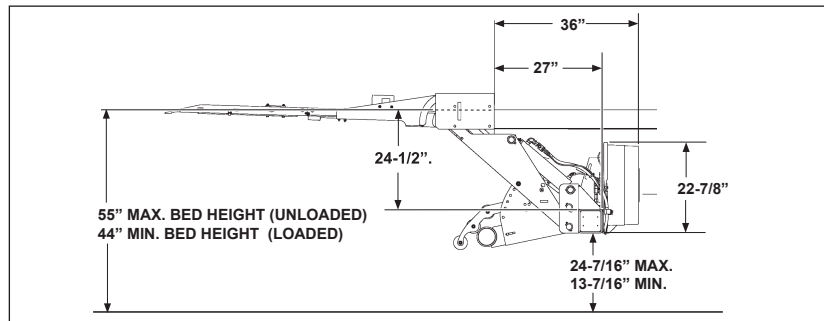

GPTLR-44 & 55 Lift Dimensions and Mounting Requirements



Maxon Lift Corp. 11921 Slauson Ave., Santa Fe Springs, CA 90670
800.227.4116 Fax 888.771.7713, www.maxonlift.com

TUK-A-WAY® SERIES

The GPTLR Series

MAXON®

Optional Features

- Power Down
- Cart Stops (Available on Aluminum Platforms Only)
- Heavy-Duty Dual Step Dock Bumpers or Dual Folding Steps
- Folding Steps
- Dual Controls
- Street Side Controls
- Cab Cut-off
- Hand-Held Controls
- Frameless Trailer Mounting Kit
- Auxiliary Hand Pump
- Cycle Counter
- Circuit Breaker Kit
- Trail Charger
- Single and Dual Pole Charge Lines & Adapters
- FMVSS or CMVSS (GPTLR 44/55 only) compliant trailer underride
- Special Order Request Options Include: Swing Door Extension Plate and 24 Volt System Pump & Motor

Loadable Platform Space with Cart Stops Deployed

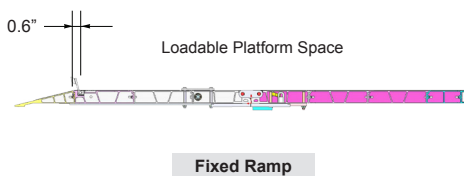

Distributed by:



Level Ride

The GPTLR rides level all the way to the ground, just like a rail liftgate. The platform design allows for loads to be easily loaded on and off because it sits completely flat on the ground.



Multiple Step Options

Bolt-on style dual step dock bumpers (shown at left) or heavy-duty dock bumpers with dual steps or dual folding steps are available as optional equipment. The folding steps may be installed on either or both sides of the liftgate.



Aluminum Platform MAX GRIP® OPTIONAL

Lightweight aluminum platform design with recessed hinges provides a flat loading surface over entire width of platform. The platform features dual assist torsion springs that minimize the opening and closing force. Optional available with knurled surface (MAX GRIP®).



Fully Galvanized - STANDARD

Galvanization is the process by which zinc is coated over corrosive (easily rusted) metals. The process of galvanizing not only protects from corrosion of various 'soft metals' but also adds strength to the original, uncoated metal

Shipped Fully Assembled

The GPTLR comes fully assembled with everything pre-wired and plumbed, and installs as one piece. Installer variability and error are virtually eliminated.

Protected Pump/Motor Assembly

The pump and motor are factory wired and installed, and even shipped with oil in the reservoir. The assembly is protected from the elements by its cover, and the main frame to which it is securely attached. It's also easy to remove, if necessary. To discourage theft, the bolt to remove the pump and motor is protected with a lockable steel collar.

Note: The GPTLR is designed for dry freight body and trailer applications only. For refrigerated, flatbed or swing door applications, please contact your MAXON Sales or Customer Service Representative to find out about alternative MAXON liftgate solutions.

M-167-1217

Patents Pending



Maxon Lift Corp. 11921 Slauson Ave., Santa Fe Springs, CA 90670
800.227.4116 Fax 888.771.7713, www.maxonlift.com