

M-00-25
REV. L
AUGUST 2012

Operation Manual Contains:

- Warnings
- Decal & Plate Locations
- Standard Control Locations
- Liftgate & Retention Ramp Operation

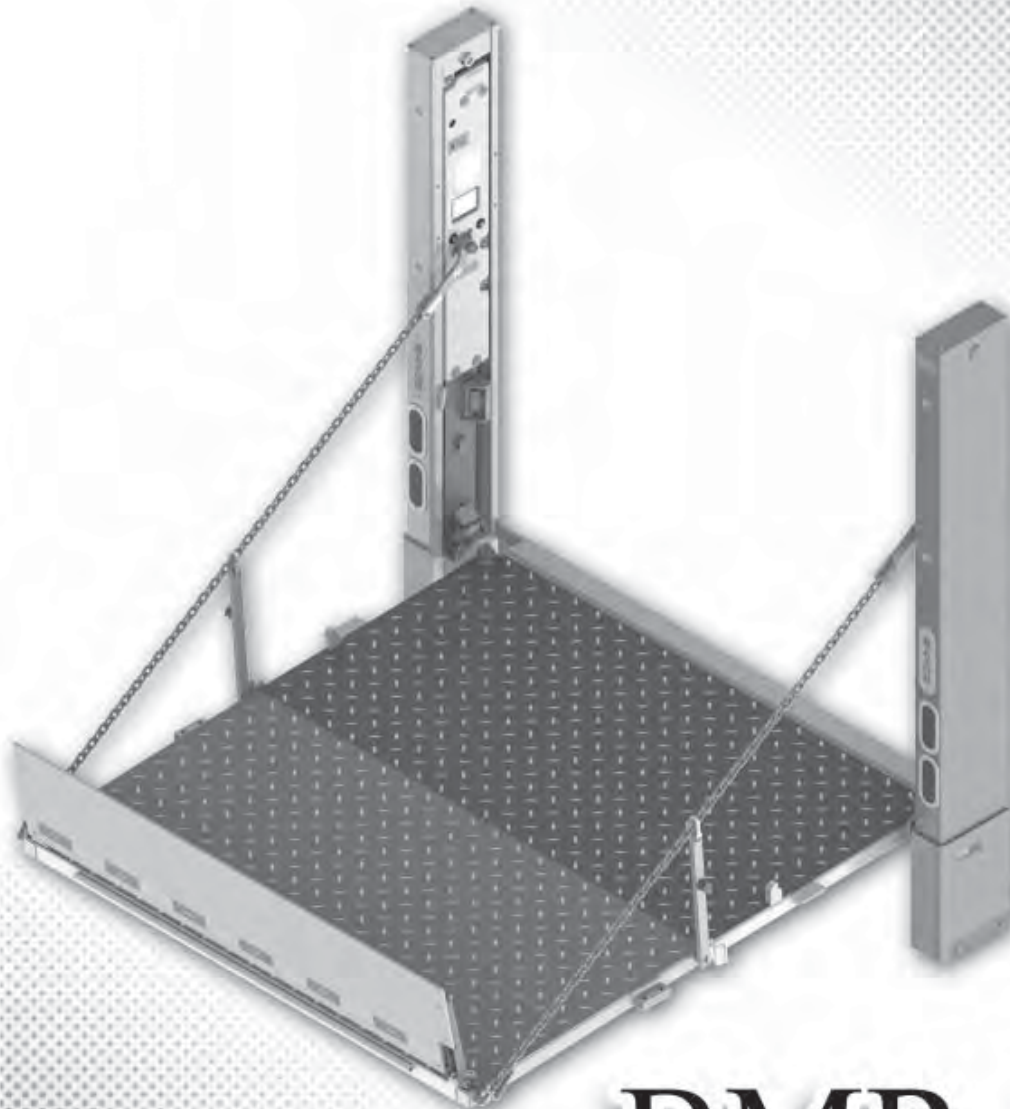

MAXON[®]
LIFT CORP.

BMR-A & BMRSD OPERATION MANUAL

© MAXON Lift Corp. 2012

KEEP THIS MANUAL IN CAB OF VEHICLE

Register your liftgate on line at www.maxonlift.com/htm/services/reg.htm.
For a free copy of other manuals that pertain to this model liftgate, please visit our website at www.maxonlift.com or customer service at (800) 227-4116.

TABLE OF CONTENTS

WARNINGS	5
DECALS & PLATES	6
STANDARD CONTROL LOCATIONS	8
PUMP BOX CONTROLS.....	9
FORKLIFT ADVISORY	11
LOADING VEHICLE	12
OPENING THE PLATFORM	12
LOWERING THE PLATFORM	12
OPENING THE RETENTION RAMP.....	13
POSITIONING LOAD	14
RAISING & UNLOADING PLATFORM.....	15
UNLOADING VEHICLE	17
OPENING THE PLATFORM	17
LOWERING THE PLATFORM	17
OPENING RAMP TO RETENTION POSITION.....	18
RAISING THE PLATFORM	19
POSITIONING LOAD	20
LOWERING & UNLOADING PLATFORM.....	21
STOWING PLATFORM	22
STOW RETENTION RAMP	22
DOCK LOADING & UNLOADING	24
LOWER PLATFORM BELOW DOCK LEVEL.....	24

THIS PAGE INTENTIONALLY LEFT BLANK

WARNING

1. Incorrect operation of this Liftgate can result in serious personal injury. Comply with **WARNINGS** and Liftgate operating instructions in this manual. Do not allow untrained persons or children to operate the Liftgate. If you need to replace an **Operation Manual**, additional copies are available from:

MAXON Lift Corp. Customer Service
11921 Slauson Ave
Santa Fe Springs, CA 90670
(800) 227-4116

2. Do not exceed rated **load capacity** of the Liftgates which is **3500 lbs. for model BMRA-35 (BMRSD-35), 4400 lbs. for model BMRA-44 (BMRSD-44), 5500 lbs. for model BMRA-55 (BMRSD-55), and 6600 lbs. for model BMRA-66 (BMRSD-66).**
3. Do not allow any part of your body to be placed under, within, or around any portion of the moving Liftgate or its mechanisms, or in a position that would trap them between the platform and the floor of truck body (or between platform and the ground) when Liftgate is operated.
4. Consider the safety and location of bystanders and location of nearby objects when operating the Liftgate. Stand to one side of platform while operating the Liftgate. Be certain that the area the Liftgate will move through during operation is clear of all obstacles.
5. Comply with all attached instruction decals and warning decals.
6. Keep decals clean and legible. If decals are illegible or missing, have them replaced. **Get free replacement decals from Maxon.**
7. **Never drive a forklift on the Liftgate platform.**
8. Do not move vehicle unless Liftgate is correctly stowed.
9. **Correctly stow platform when not in use. Extended platforms could create a hazard for people and vehicles passing by.**
10. A correctly installed Liftgate will operate smoothly and reasonably quiet. The only noticeable noise, during Liftgate operation, is from the power unit while the platform is being opened (SD models only), lowered (power down models only), raised, or closed. Listen for scraping, grating and binding noises and have the problem corrected before continuing to operate the Liftgate.
11. Above all, **USE GOOD COMMON SENSE** when operating this Liftgate.
12. Never use a cell phone while operating the Liftgate.

DECALS & PLATES

NOTE: Ensure there is no residue, dirt, or corrosion where decals are attached. If necessary, clean surface before attaching decals.

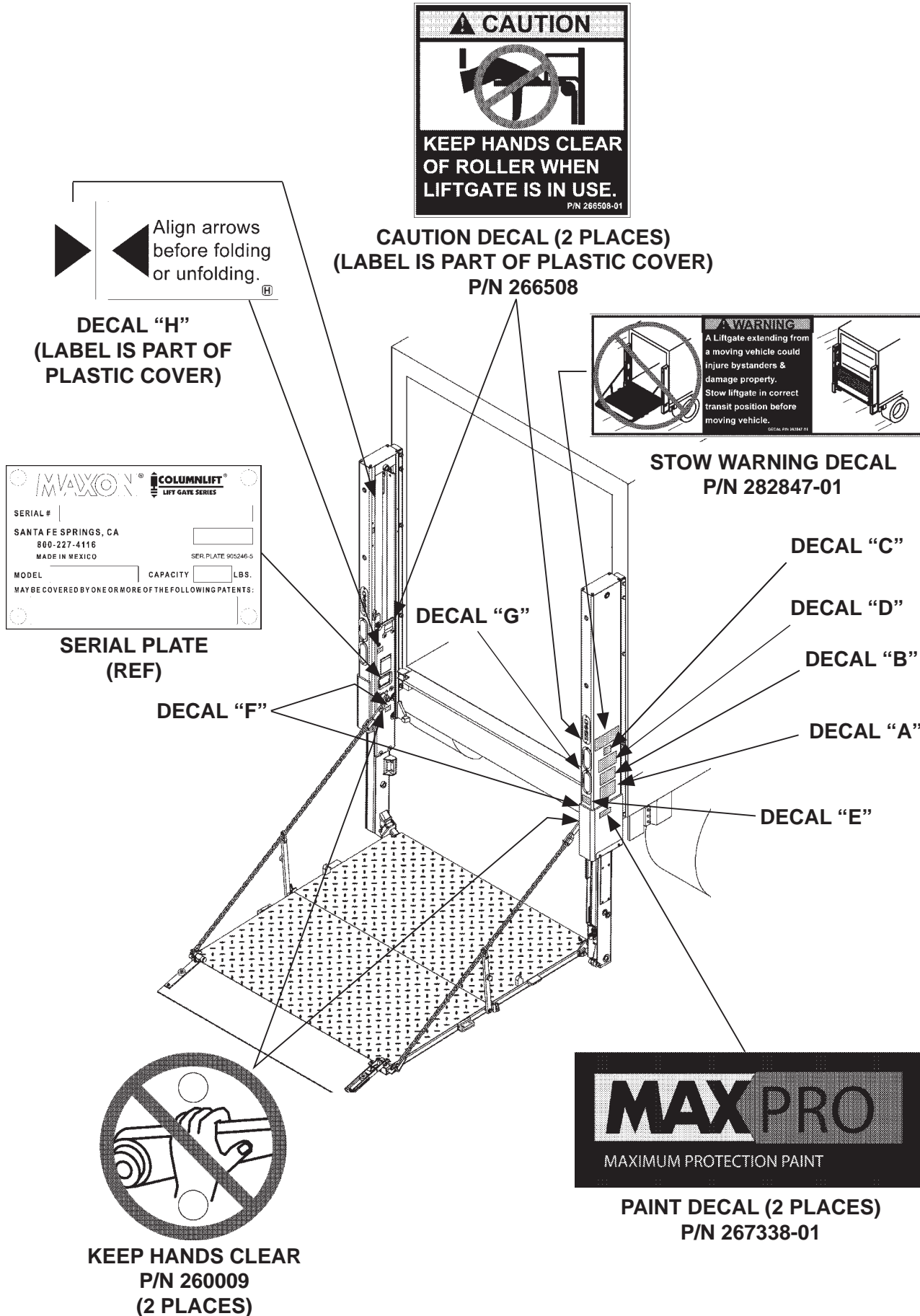

FIG. 6-1

SAFETY INSTRUCTIONS

Read all decals and operation manual before operating liftgate.

1. Do not use liftgate unless you have been properly instructed and have read, and are familiar with, the operating instructions.
2. Be certain vehicle is properly and securely braked before using the liftgate.
3. Always inspect this liftgate for maintenance or damage before using it. Do not use liftgate if it shows any sign of damage or improper maintenance.
4. Do not overload.
5. Make certain the area in which the platform will open and close is clear before opening or closing the platform.
6. Make certain platform area, including the area in which loads may fall from platform, is clear before and at all times during operation of liftgate.
7. This liftgate is intended for loading and unloading of cargo only. Do not use this liftgate for anything but its intended use.

A

WARNING

Read this information carefully.

- Improper operation of this Liftgate can result in serious personal injury. If you do not have a copy of the operating instructions, please obtain them from your employer, distributor, or lessor before you attempt to operate Liftgate.
- If there are signs of improper maintenance, damage to vital parts, or slippery platform surface, do not use the Liftgate until these problems have been corrected.
- If you are using a pallet jack, be sure it can be maneuvered safely.
- Do not operate a forklift on the platform.
- Do not allow any part of yours or your helper's body to be placed under, within, or around any portion of the moving Liftgate, or its mechanisms, or in a position that would trap them between the platform and the ground or truck when the Liftgate is operated.
- If a helper is riding the platform with you, make sure you are both doing so safely and that you are not in danger of coming in contact with any moving or potentially moving obstacles.
- **USE GOOD COMMON SENSE**
- If load appears to be unsafe, do not lift or lower it.

For a free copy of other manuals that pertain to this model Liftgate, please visit our website at www.maxonlift.com or call Customer Service at (800) 227-4116.

B

THE MAXIMUM CAPACITY OF THIS LIFT IS

___ LB [___ KG]

WHEN THE LOAD IS CENTERED ON THE LOAD CARRYING PLATFORM

C

(REFER TO TABLE 7-1)



WARNING

Liftgate hazards can result in crushing or falling.

Keep hands and feet clear of pinch points.

If riding liftgate, make sure load is stable and footing is solid.

D

Read and understand all instructions and WARNINGS before use.

CAUTION

Always stand clear of platform area.

E

UP ↑

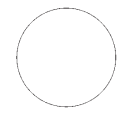

DOWN ↓

G



Align arrows before folding or unfolding.

H

Cut off at dotted lines. Discard this piece.

(LABEL IS PART OF PLASTIC COVER)

CAUTION

Do not grease columns.

F

(LABEL IS PART OF PLASTIC COVER)

**DECAL SHEET
FIG. 7-1**

MODEL	ORDER P/N	DECAL "C"
BMRA-35 & BMRSD-35	268309-01	3500 POUNDS [1600 KG]
BMRA-44 & BMRSD-44	268309-02	4400 POUNDS [2000 KG]
BMRA-55 & BMRSD-55	268309-03	5500 POUNDS [2500 KG]
BMRA-66 & BMRSD-66	268309-04	6600 POUNDS [3000 KG]

**DECAL SHEET PART NUMBERS
TABLE 7-1**

STANDARD CONTROL LOCATIONS

GROUND ACCESS - CONTROL BOX

Toggle switches on control box (**FIG. 8-1A**) let operator raise (**UP**), lower (**DOWN**), **FOLD**, and **UNFOLD** the platform (**FIG. 8-1B**) while standing on the ground.

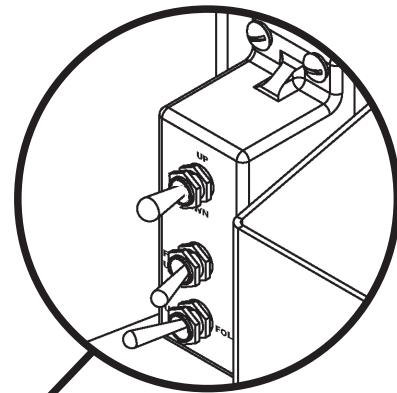

FIG. 8-1A

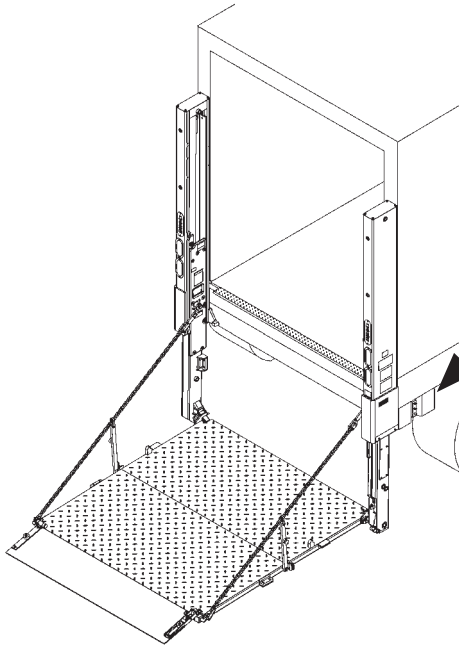

FIG. 8-1B

PLATFORM ACCESS - RUNNER SWITCH

Toggle switch (**FIG. 8-2A**) on RH runner lets operator raise (**UP**) and lower (**DOWN**) the platform (**FIG. 8-2B**) only. Switch stays within reach when operator rides platform **UP** and **DOWN**.

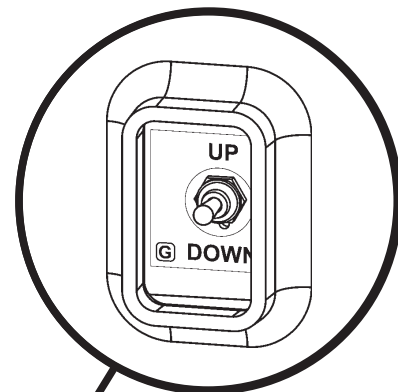

FIG. 8-2A

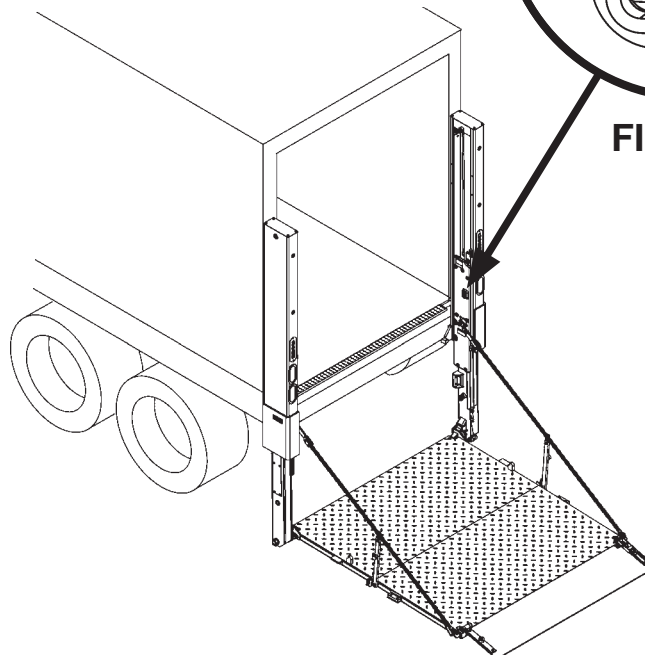
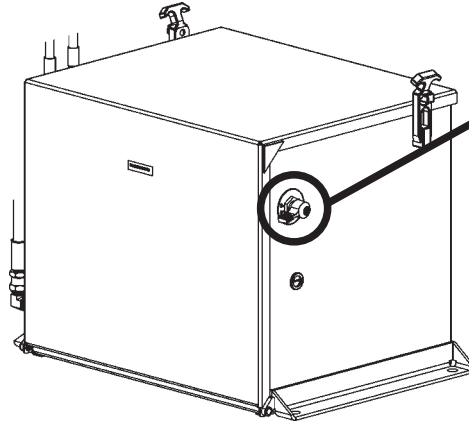

FIG. 8-2B

PUMP BOX CONTROLS

MASTER DISCONNECT SWITCH

The master disconnect switch (**FIGS. 9-1B and 9-2B**) removes battery power from the pump(s). For a single pump box (**FIGS. 9-1A and 9-1B**), turn **ON** the master disconnect switch to operate Liftgate.



**SINGLE PUMP BOX
FIG. 9-1A**

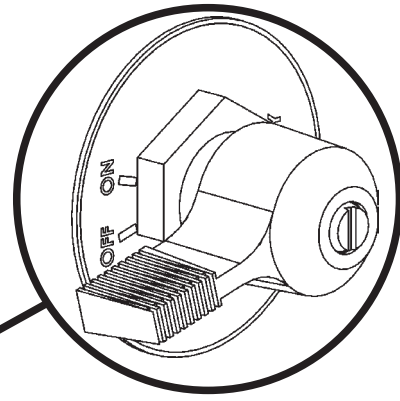

**MASTER DISCONNECT SWITCH TURNED OFF
FIG. 9-1B**

To operate a Liftgate equipped with dual pump box (**FIGS. 9-2A and 9-2B**), turn the master disconnect switch to **1&2**. If necessary, battery power can be connected to one pump only by selecting **1** or **2**. To remove battery power from **PUMPS 1 and 2**, turn switch **OFF**.

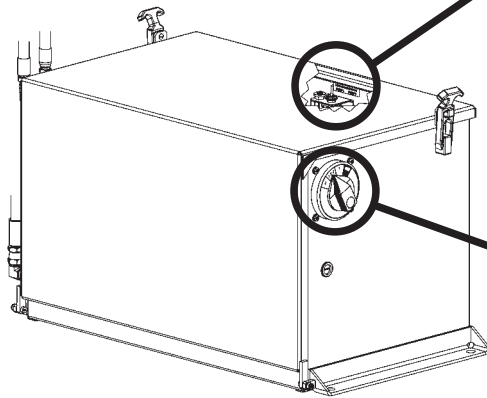

**DUAL PUMP BOX
FIG. 9-2A**

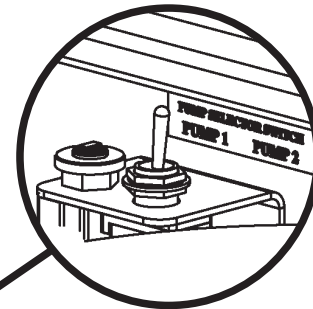

**SELECTOR SWITCH
(PUMP 2 SELECTED)
FIG. 9-2C**

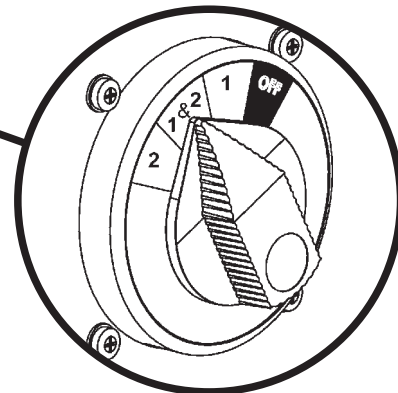

**MASTER DISCONNECT SWITCH
(PUMPS 1&2 CONNECTED)
FIG. 9-2B**

PUMP SELECTOR SWITCH

If the Liftgate is equipped with a dual pump box (**FIG. 9-2A**), the **PUMP SELECTOR SWITCH (FIG. 9-2C)** can be used to select **PUMP 1** or **PUMP 2** to power Liftgate.

PUMP BOX CONTROLS - Continued

POWER DOWN ON DEMAND SWITCH (BMRSD MODELS ONLY)

The power down switch (**FIG. 10-1B**) selects Gravity Down (**GD**) or Power Down (**PD**) operation of the Liftgate. Setting the switch to **GD** should result in more operating time from a charged battery. The **PD** switch setting should improve performance when operating in severe cold weather.

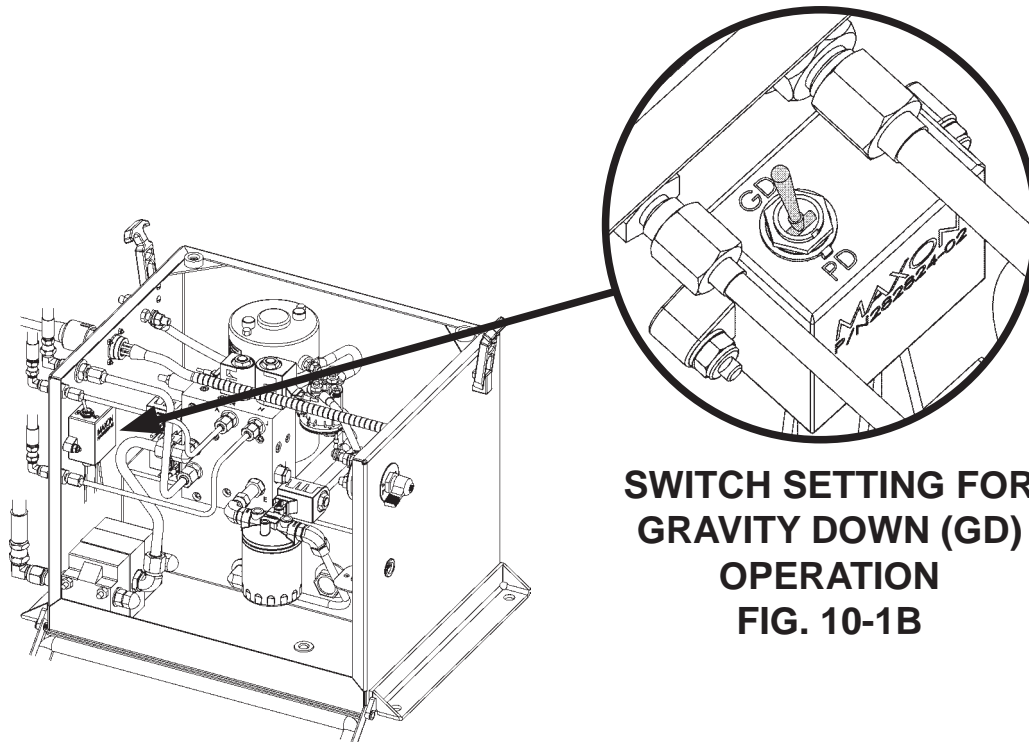

**SINGLE PUMP BOX
FIG. 10-1A**

**SWITCH SETTING FOR
GRAVITY DOWN (GD)
OPERATION
FIG. 10-1B**

FORKLIFT ADVISORY

⚠ WARNING
Keep forklift OFF of platform.

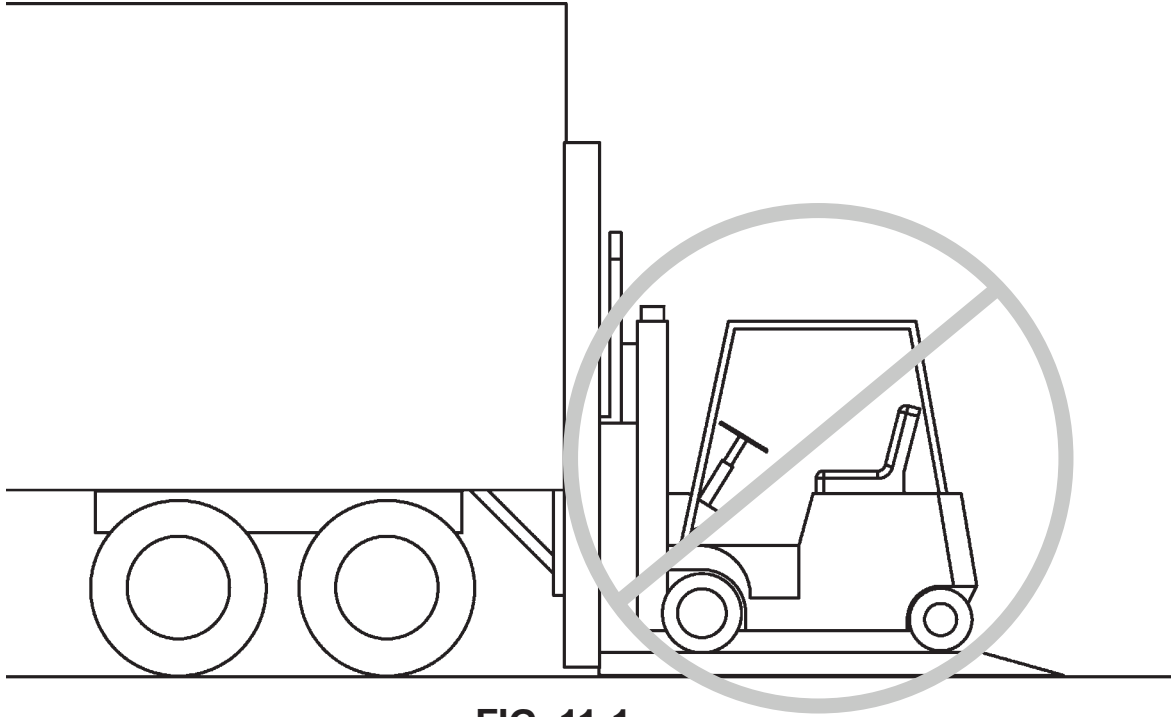

FIG. 11-1

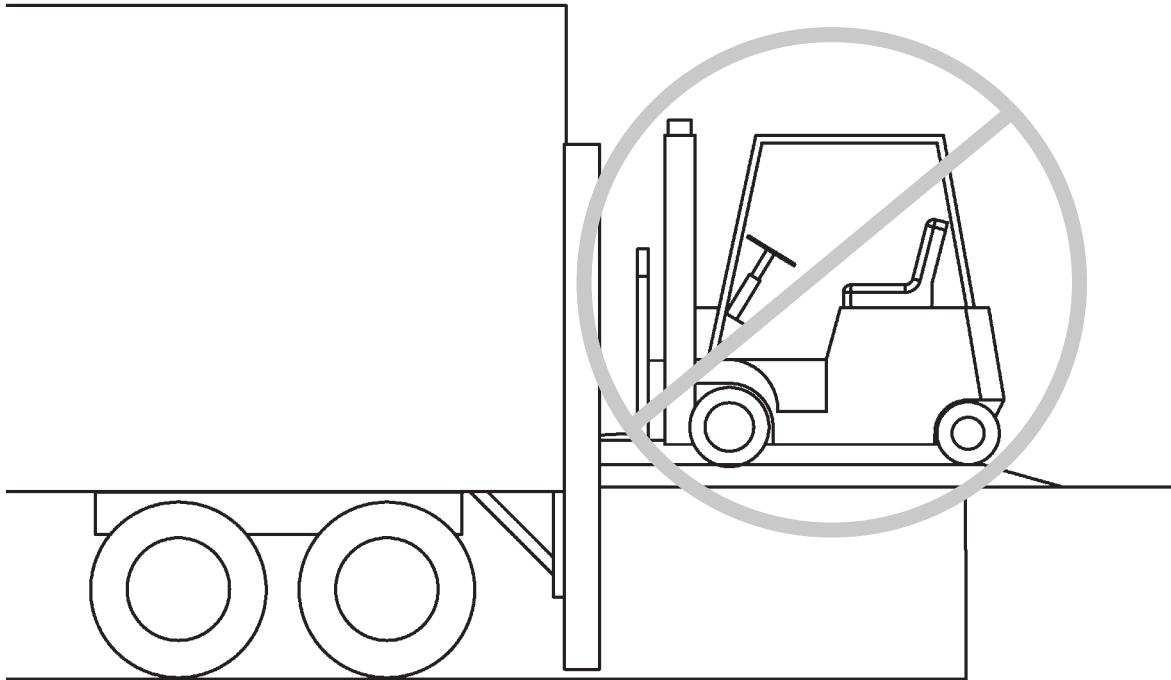
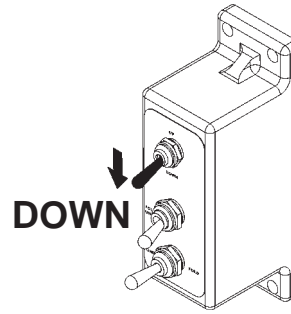

FIG. 11-2

LOADING VEHICLE OPENING THE PLATFORM

Push toggle switch to **DOWN** position (**FIG. 12-1**) to lower platform (**FIG. 12-2A**) until arrow decals are about even (**FIG. 12-2B**). Platform will be released from the locking wedges on the Liftgate column. Next, use control box to **UNFOLD** platform (**FIG. 12-2A**). Hold both switches until platform reaches the unfolded (horizontal) position and then release both switches.



**CONTROL BOX
FIG. 12-1**

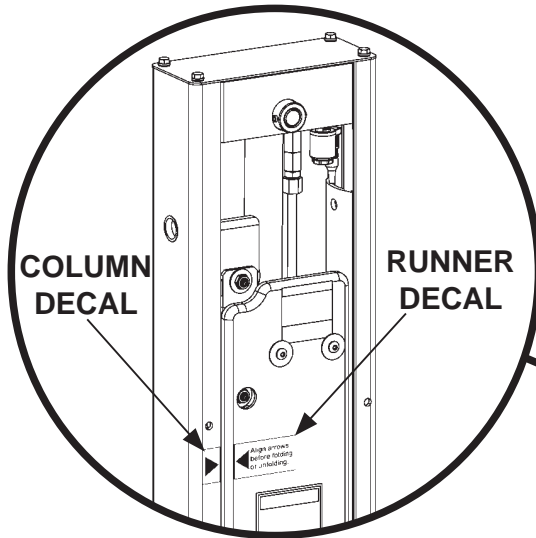

FIG. 12-2B

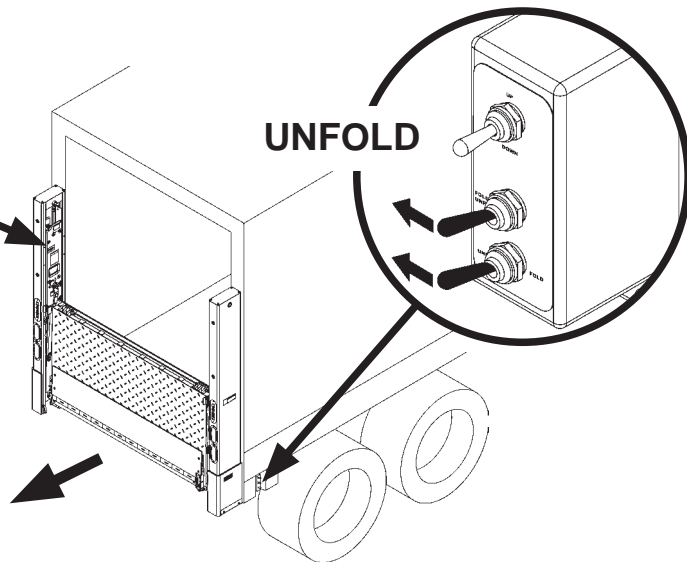

FIG. 12-2A

LOWERING THE PLATFORM

To lower platform to the ground, use control box as shown in **FIG. 12-3**. Release toggle switch when platform reaches the ground.

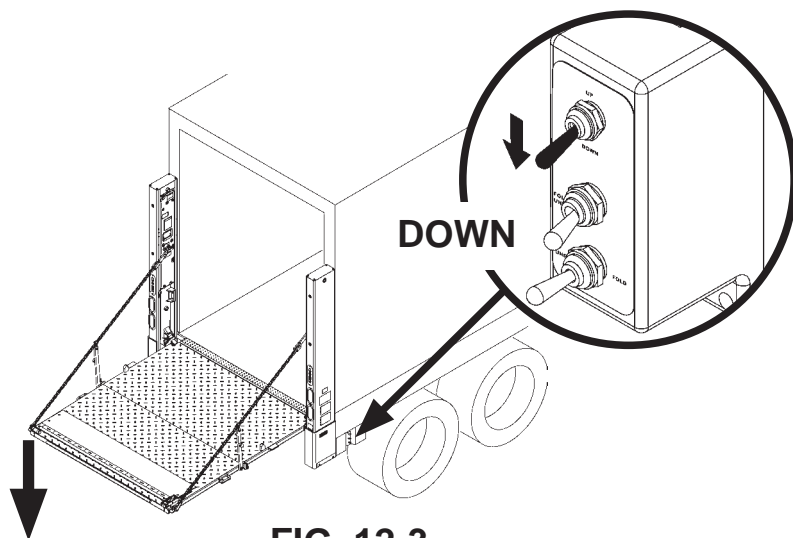

FIG. 12-3

OPENING THE RETENTION RAMP

To unfold retention ramp, first push down on retention ramp (**FIG. 13-1A**) to release tension on lock. To unfold ramp for loading, release and hold lock (**FIG. 13-1B**) and rotate ramp to the ground (**FIG. 13-2**).

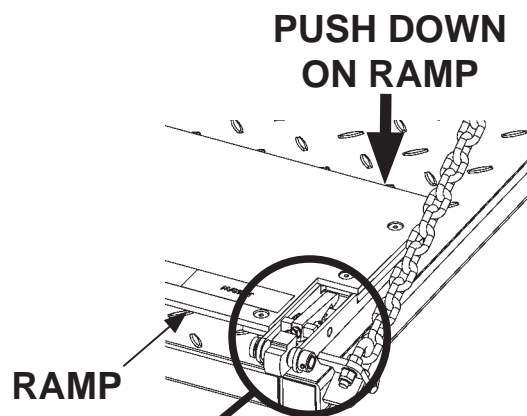

FIG. 13-1A

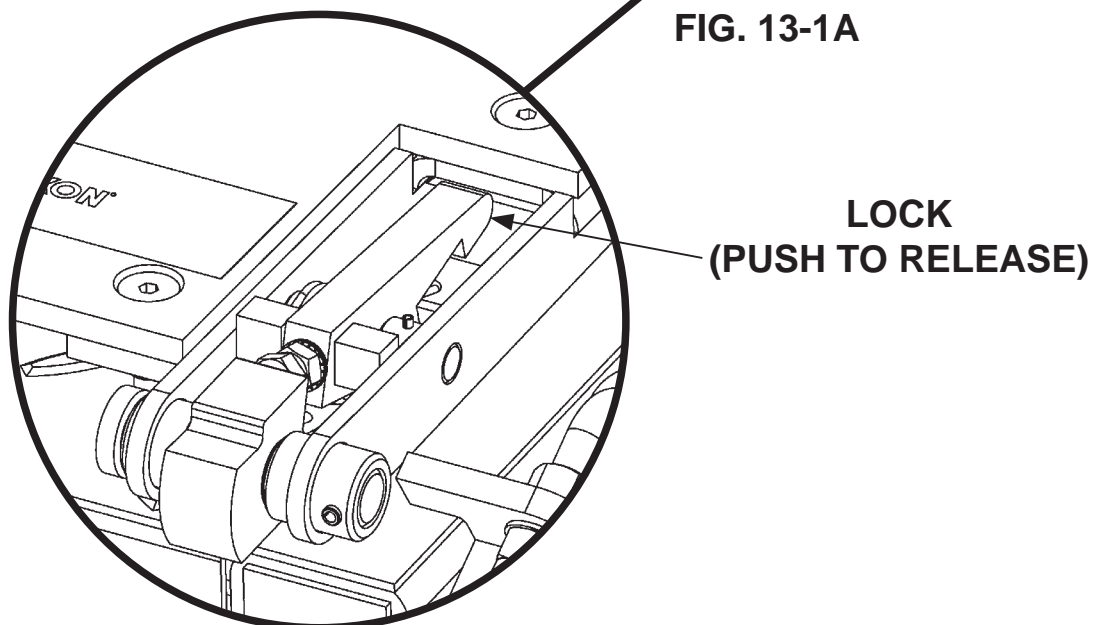

FIG. 13-1B

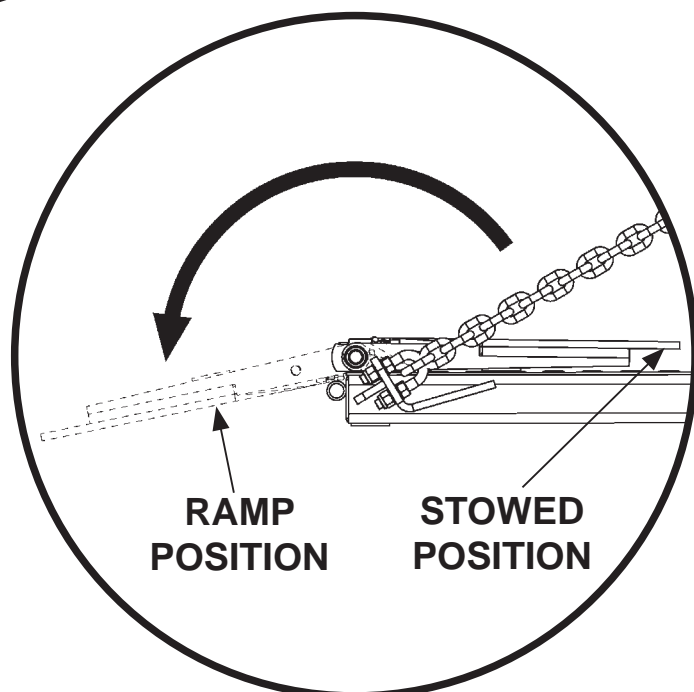

FIG. 13-2

LOADING VEHICLE - Continued POSITIONING LOAD

WARNING

A load should never extend past the edges of the platform. Do not place unstable loads on platform and do not allow load to exceed lifting capacity of Liftgate. If standing on platform, do not allow your feet to extend beyond inboard edge of platform.

Place all loads as close as possible to the inboard edge of the platform with heaviest part toward the truck body as shown in **FIG. 14-1**. Move loads across the ramp (**FIG. 14-1**) to the platform, but never rest or raise loads on the ramp. If standing on platform with the load, stand in the footprint area shown and comply with the preceding **WARNING**.

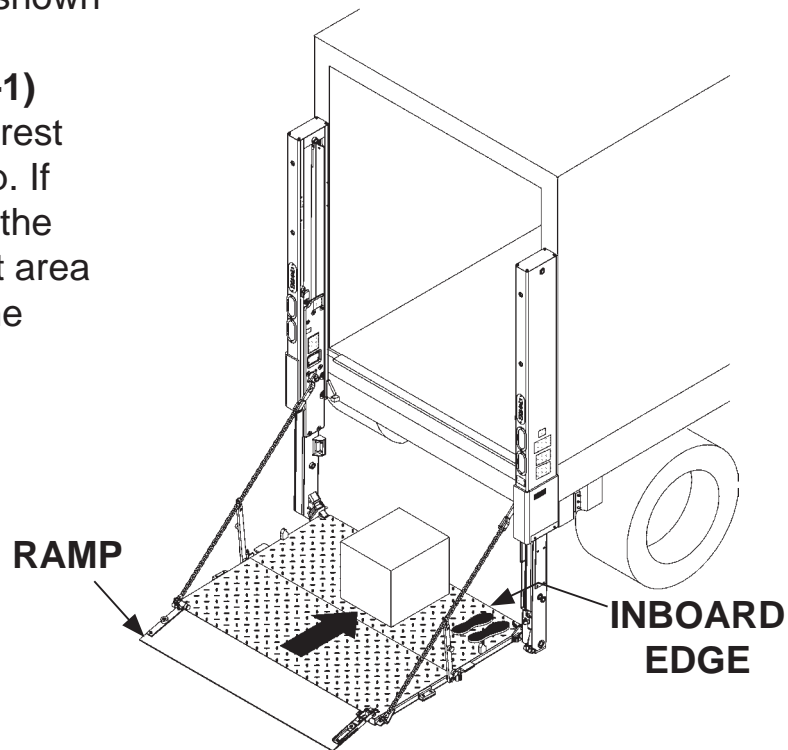

**LOADING PLATFORM AT GROUND LEVEL
FIG. 14-1**

RAISING & UNLOADING PLATFORM

⚠ CAUTION

A ramp in retention position can trip you when stepping over it. To prevent possible injury, get on the platform before putting the ramp in retention position.

1. Fold ramp until it locks in retention position (FIG. 15-1B).

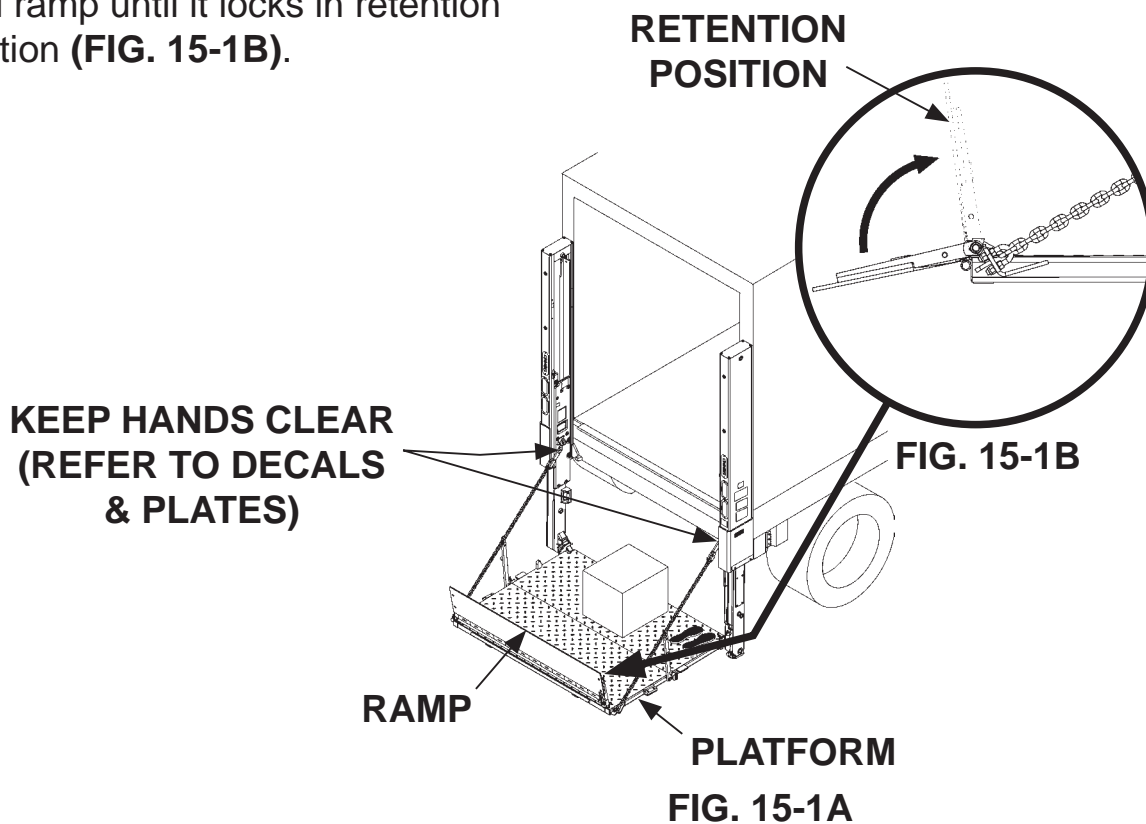

2. Use runner switch to raise (UP) platform from ground level to bed height (FIG. 15-2). Release switch when platform reaches bed height.

3. Carefully move the load into vehicle (FIG. 15-2).

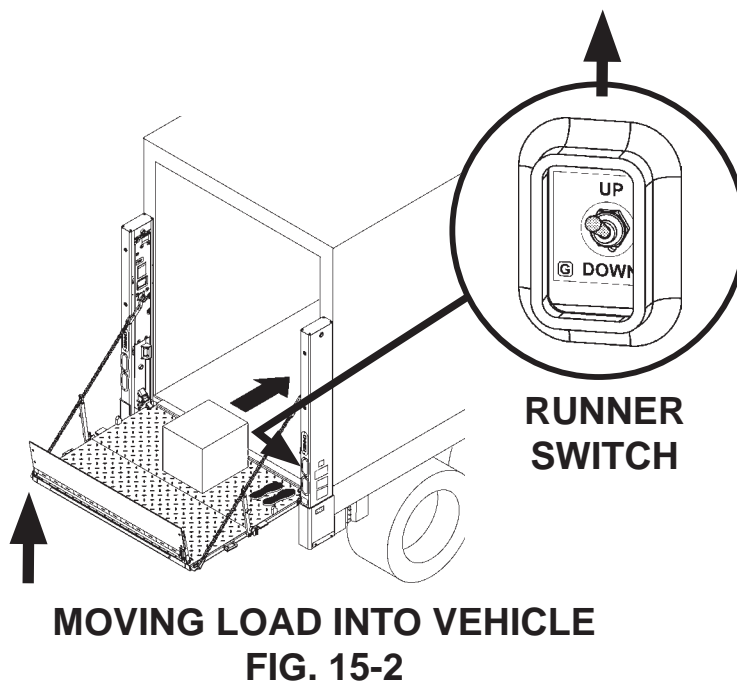

LOADING VEHICLE - Continued

RAISING & UNLOADING PLATFORM - Continued

4. Use runner switch to lower the platform to ground level (**FIG. 16-1**).

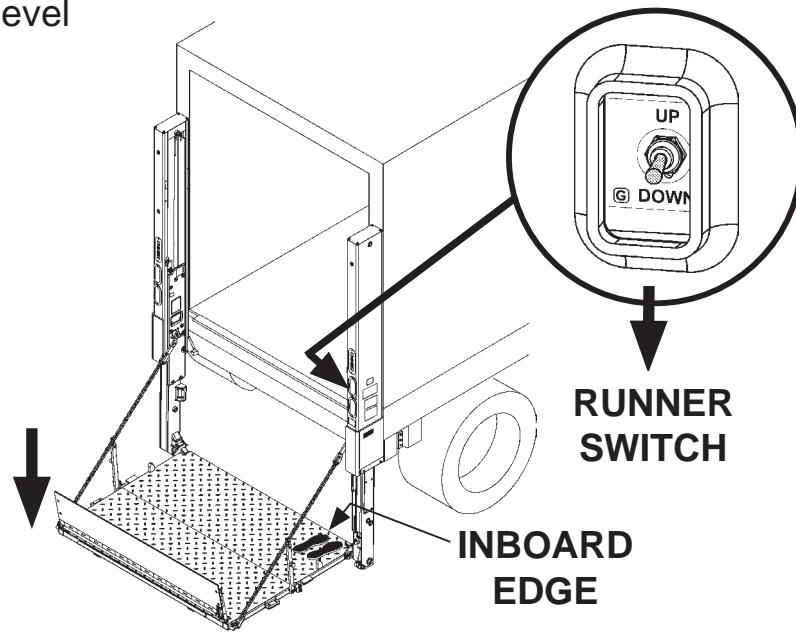

FIG. 16-1

5. If there are more loads to put in vehicle, repeat the previous **LOADING VEHICLE** steps for each load. When loading is finished, use **STOWING PLATFORM** procedure in this manual.

UNLOADING VEHICLE OPENING THE PLATFORM

Push toggle switch to **DOWN** position (**FIG. 17-1**) to lower platform (**FIG. 17-2A**) until arrow decals are about even (**FIG. 17-2B**). Platform will be released from the locking wedges on the Liftgate column. Next, use control box to **UNFOLD** platform (**FIG. 17-2A**). Hold both switches until platform reaches the unfolded (horizontal) position and then release both switches.

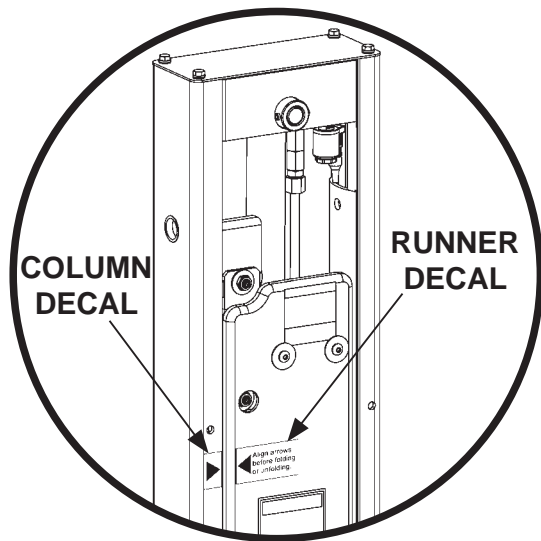
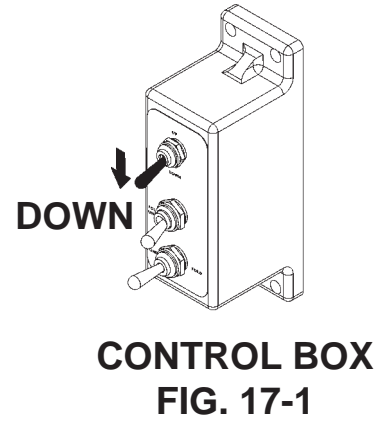

FIG. 17-2B

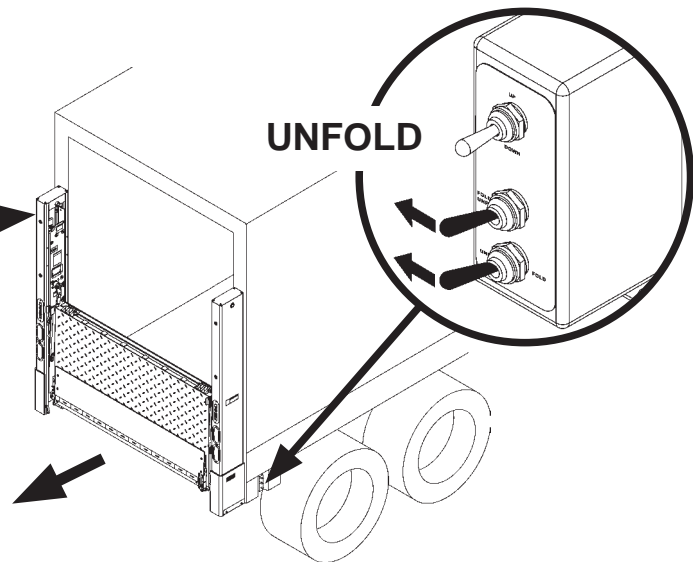

FIG. 17-2A

LOWERING THE PLATFORM

To lower platform to the ground, use control box as shown in **FIG. 17-3**. Release toggle switch when platform reaches the ground.

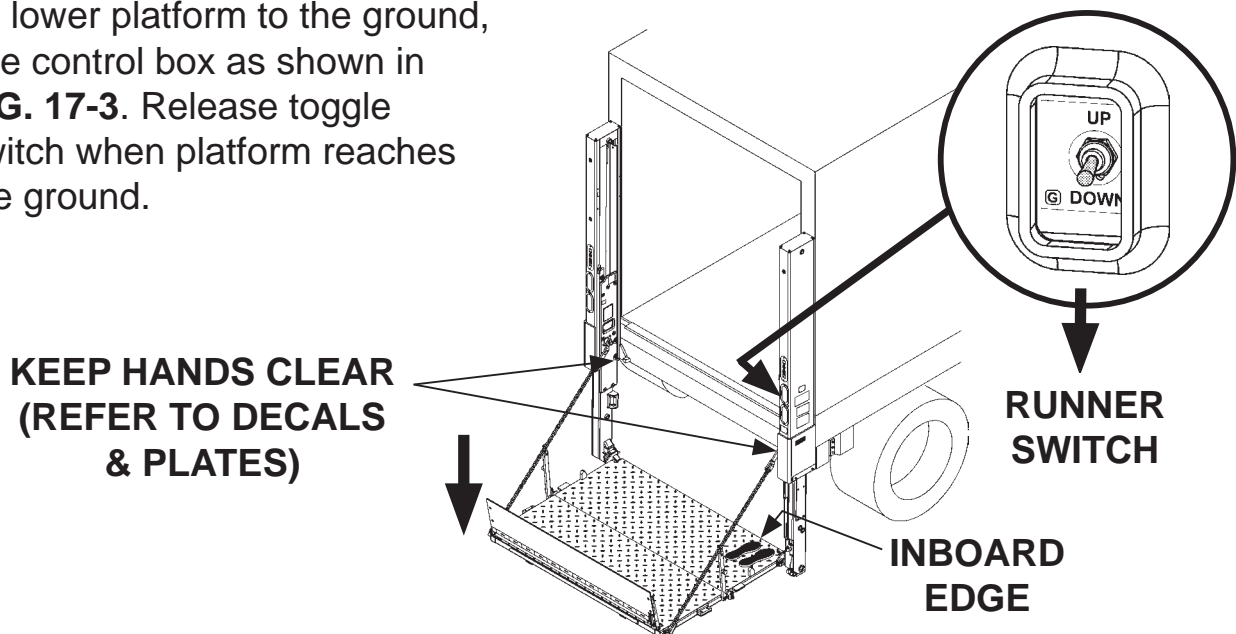

FIG. 17-3

UNLOADING VEHICLE - Continued

OPENING RAMP TO RETENTION POSITION

⚠ CAUTION

A ramp in retention position can trip you when stepping over it. To prevent possible injury, get on the platform before putting the ramp in retention position.

To unfold retention ramp, first push down on retention ramp (**FIG. 18-1A**) to release tension on lock. Next, push down on lock mechanism (**FIG. 18-1B**) and lift the retention ramp until it locks in the retention position (**FIG. 18-2**).

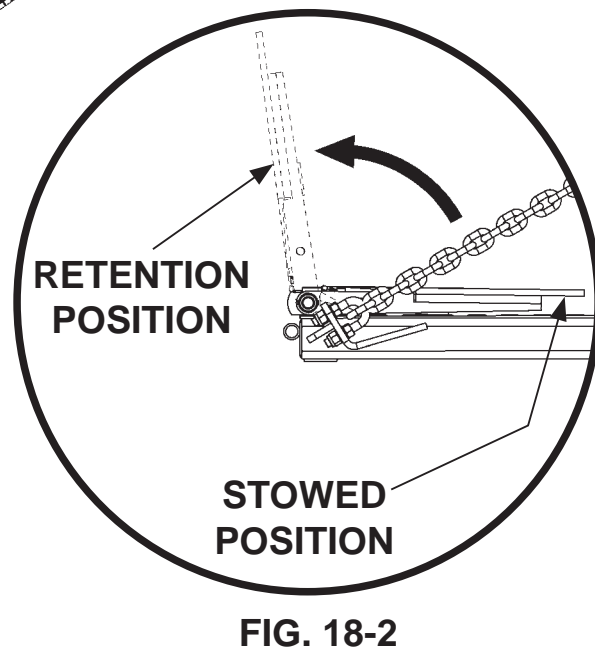
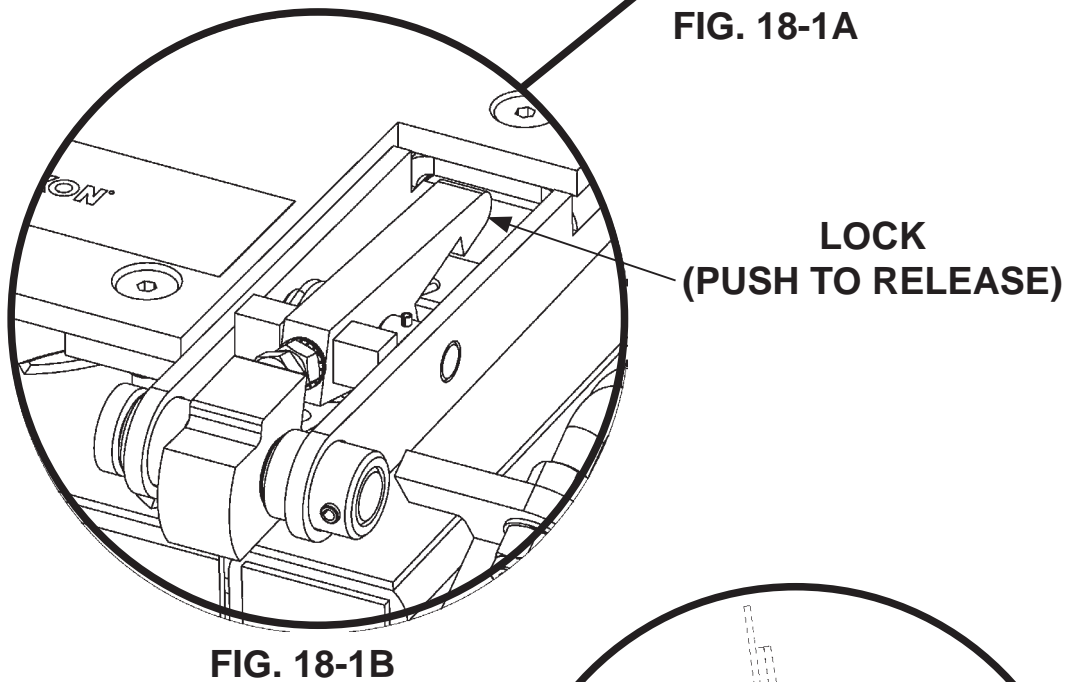
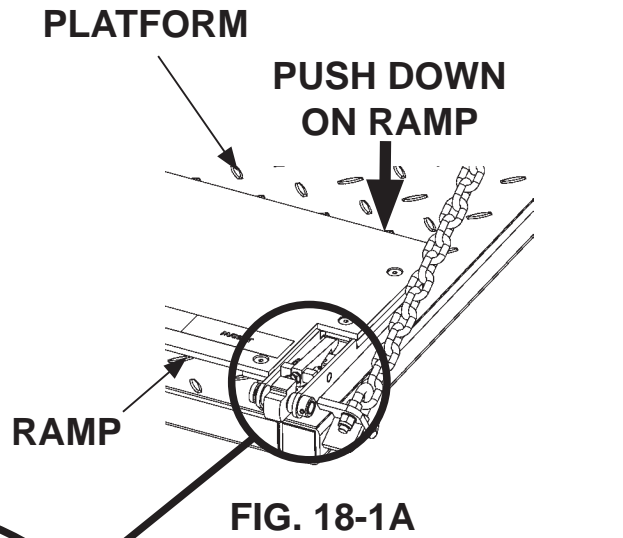

RAISING THE PLATFORM

Use runner switch to raise platform
(FIG. 19-1) from ground level to
bed height. Release switch when
platform reaches bed height.

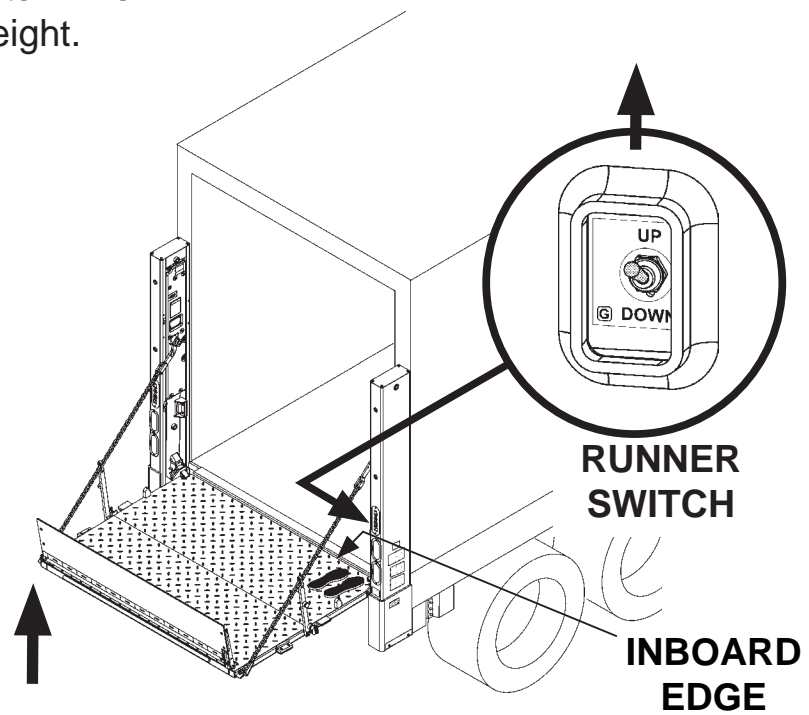

FIG. 19-1

UNLOADING VEHICLE - Continued POSITIONING LOAD

! WARNING

A load should never extend past the edges of the platform. Do not place unstable loads on platform and do not allow load to exceed lifting capacity of Liftgate. If standing on platform, do not allow your feet to extend beyond inboard edge of platform.

! WARNING

Pulling the load from vehicle to platform can result in a fall from platform and serious injury. When unloading vehicle, always push the load out on the platform.

Load the platform at bed level (**FIG. 20-1**) as follows. Push load out of the vehicle to correct position on the platform. Place all loads as close as possible to the inboard edge of the platform with heaviest part toward the vehicle body as shown in **FIG. 20-1**. If standing on platform with the load, stand in the footprint area shown and comply with the **WARNING** at the top of this page.

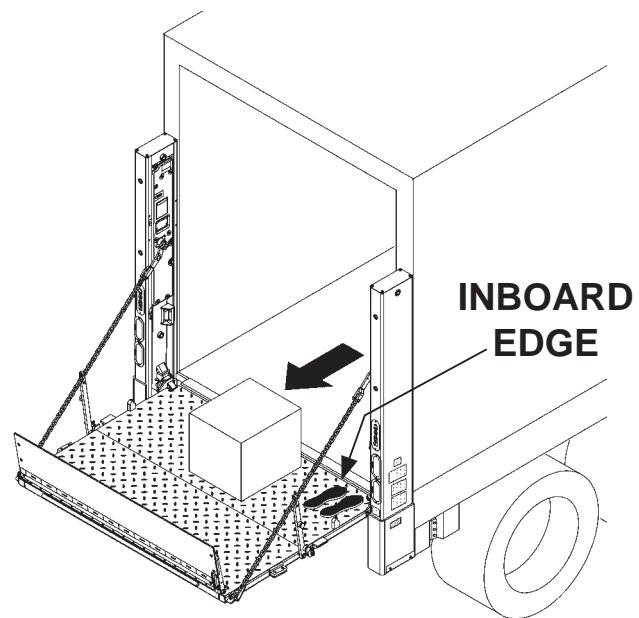

**PUSHING LOAD ON PLATFORM
FIG. 20-1**

LOWERING & UNLOADING PLATFORM

WARNING

Before lowering platform, make sure area surrounding platform is clear of people and objects. If standing on platform, do not allow your feet to extend beyond inboard edge of platform.

1. Use runner switch to lower platform to the ground (**FIG. 21-1A**). Release switch when platform reaches ground level.

2. Push down on lock mechanism and lower retention ramp to the ramp position (**FIG. 21-1B**).

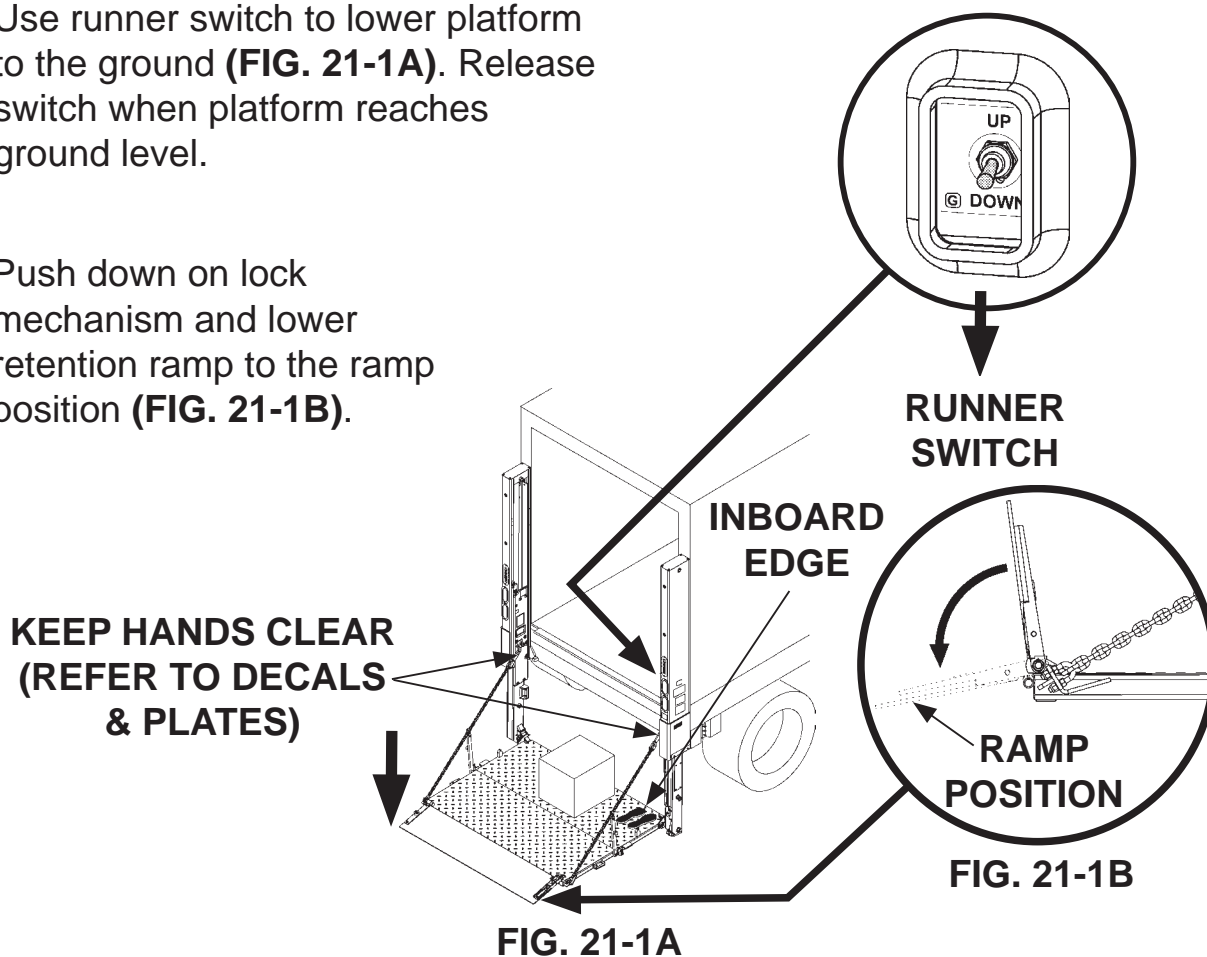

3. Carefully move load off platform (**FIG. 21-2**) and then move it to a place where it will not become a hazard for people and other vehicles. If there is more to unload from vehicle, repeat the previous **UNLOADING VEHICLE** steps for each load. When unloading is finished, use **STOWING PLATFORM** procedure in this manual.

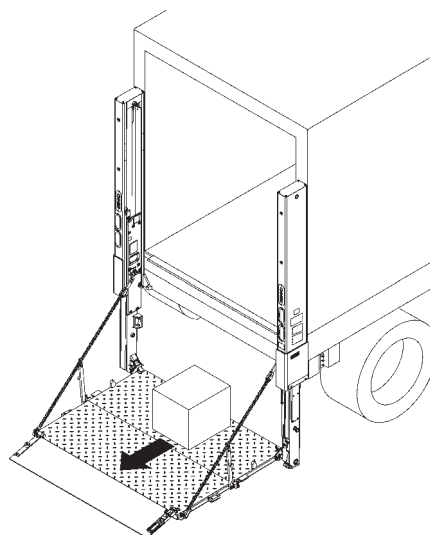

MOVING LOAD OFF PLATFORM
FIG. 21-2

STOWING PLATFORM STOW RETENTION RAMP

Push retention ramp to stowed position as shown in FIGS. 22-1A & 22-1B.

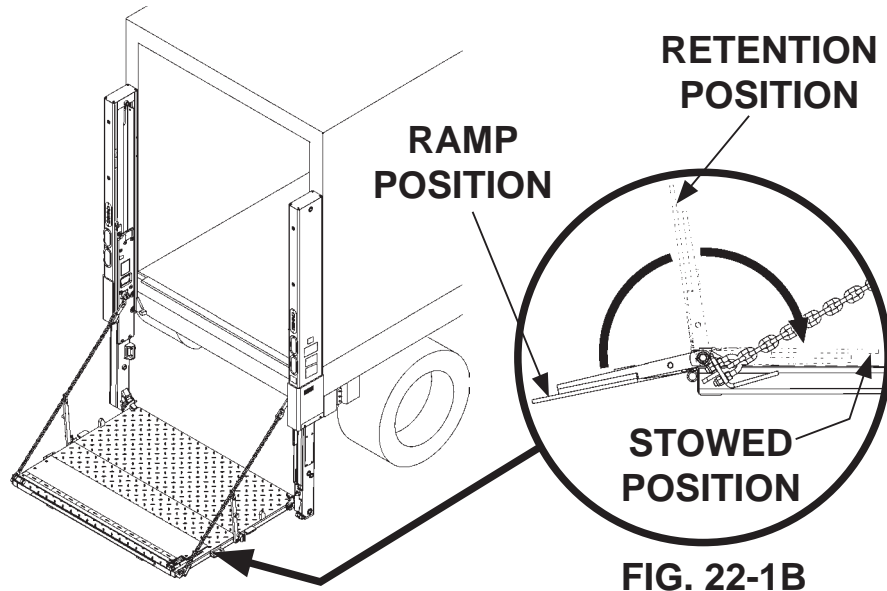

FIG. 22-1A

FIG. 22-1B

STOW PLATFORM

CAUTION

Platform and bottom stops could be damaged if platform is folded with heel below the column bottom stops. Bottom stops will interfere with folded platform being raised to up position. Prevent damage by aligning arrow decals on column & runner before folding platform. Then, platform heel will be above the bottom stops.

1. Use control box to raise (UP) platform (FIG. 22-2A) until decals on LH column are aligned (FIG. 22-2B).

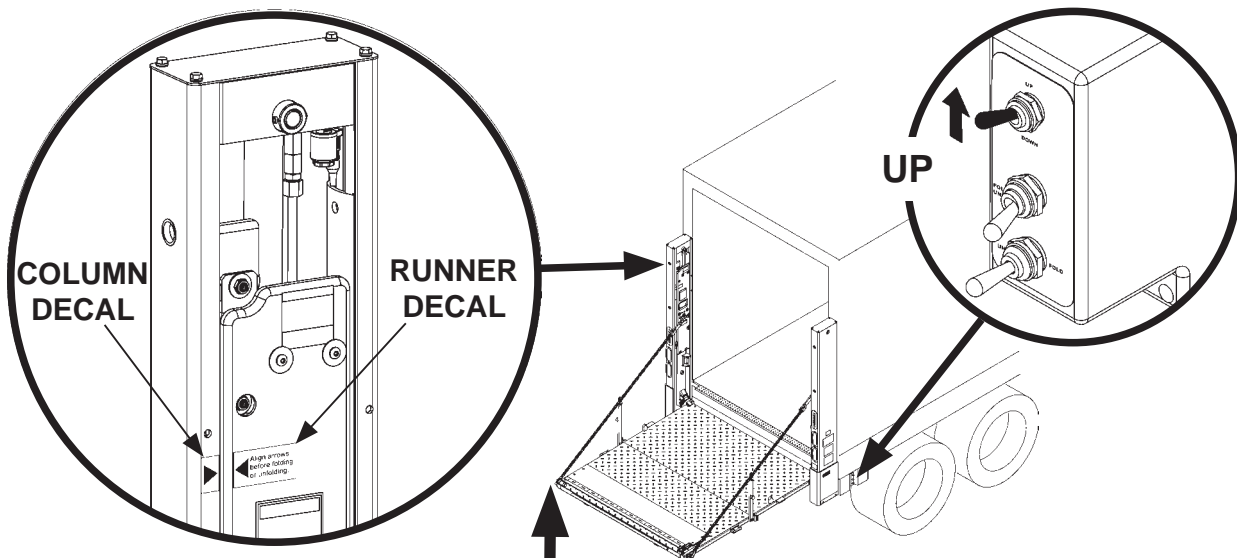

FIG. 22-2B

FIG. 22-2A

2. Use control box to **FOLD** platform (**FIG. 23-1**).

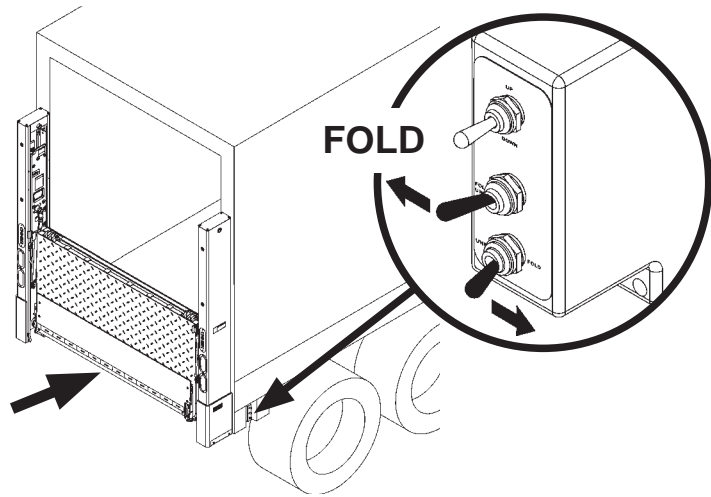
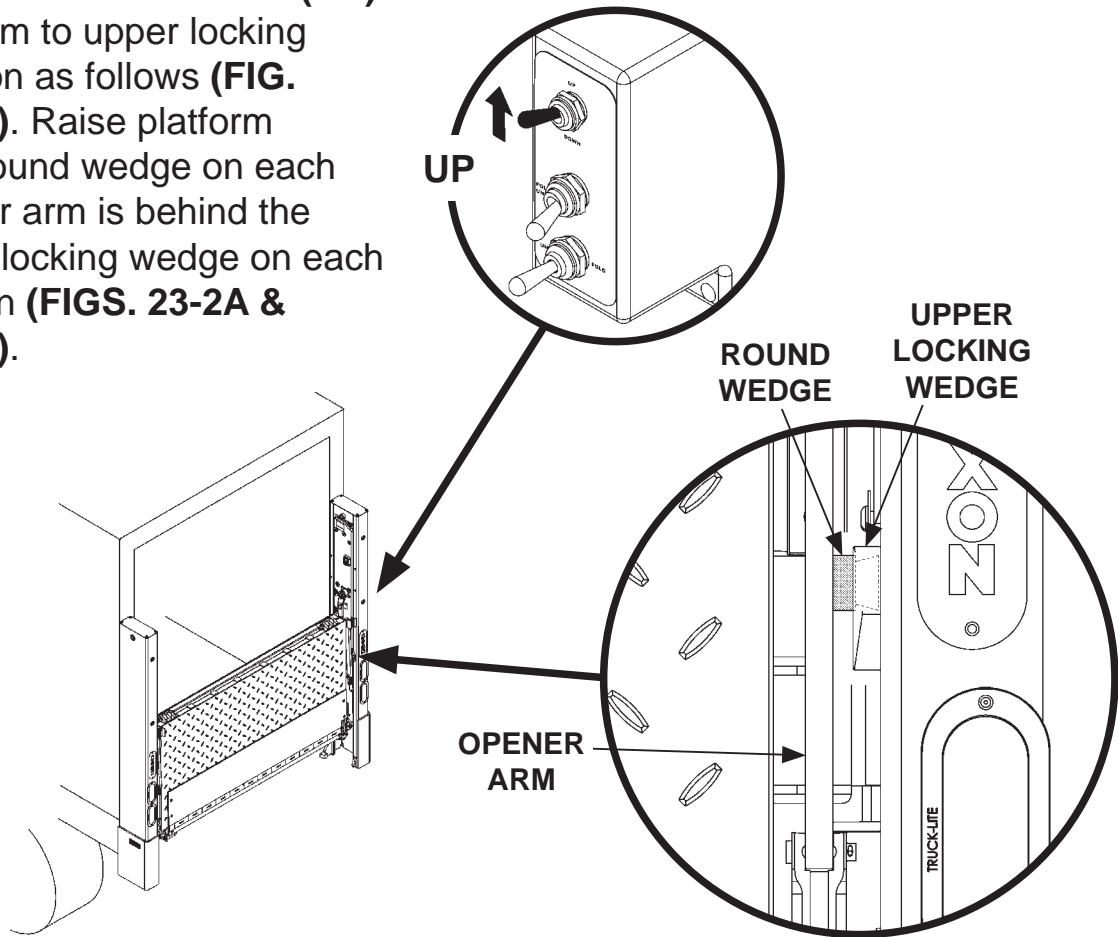

FIG. 23-1

⚠ WARNING
Upper locking wedges must be engaged before moving vehicle.

3. Use control box to raise (**UP**) platform to upper locking position as follows (**FIG. 23-2A**). Raise platform until round wedge on each opener arm is behind the upper locking wedge on each column (**FIGS. 23-2A & 23-2B**).



PLATFORM STOWED IN UPPER LOCKED POSITION
FIG. 23-2A

UPPER LOCKING WEDGE ENGAGED (CHAIN REMOVED FROM VIEW)
FIG. 23-2B

DOCK LOADING & UNLOADING LOWER PLATFORM BELOW DOCK LEVEL

⚠ CAUTION

Use dock plate for moving loads between dock and vehicle. Dock plate must be supported by dock and vehicle floor. It must not rest on Liftgate platform.

NOTE: Platform may be lowered with vehicle backed up to dock.

1. Use control box to lower (**DOWN**) platform until it rests on bottom stops (**FIG. 24-1**). Release switch when top edge of closed platform is below bed height and dock level, and in the lower locking position (**FIG. 24-1**). Now, loads can be moved between dock and vehicle without using Liftgate.

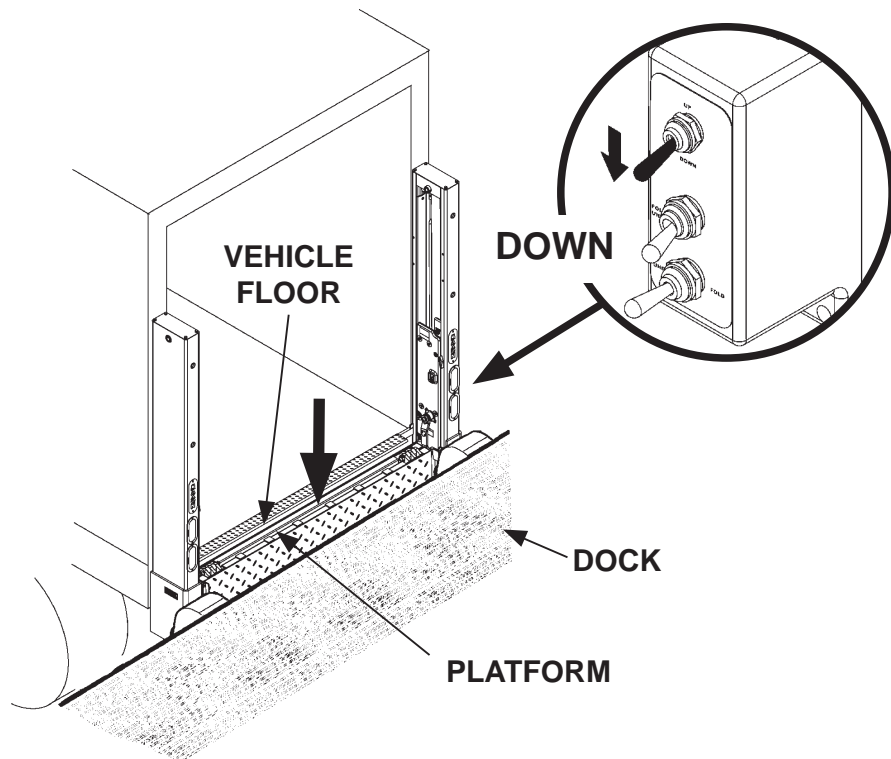

**LOWER LOCKING POSITION
FIG. 24-1**

! WARNING

Upper locking wedges must be engaged before moving vehicle.

2. When finished loading and unloading from the dock, use control box to raise **(UP)** platform to upper locking position as follows **(FIG. 25-1A)**. Raise platform, until the round wedge on each opener arm is behind upper locking wedge on each column **(FIGS. 25-1A & 25-1B)**.

