

M-00-26
REV. L
AUGUST 2012

Maintenance Manual Contains:

- Warranty Information
- Warnings
- Service Time Chart
- Periodic Maintenance Checklist
- Service and Maintenance Instructions
- Decals
- Hydraulic & Electrical System Diagrams
- Troubleshooting

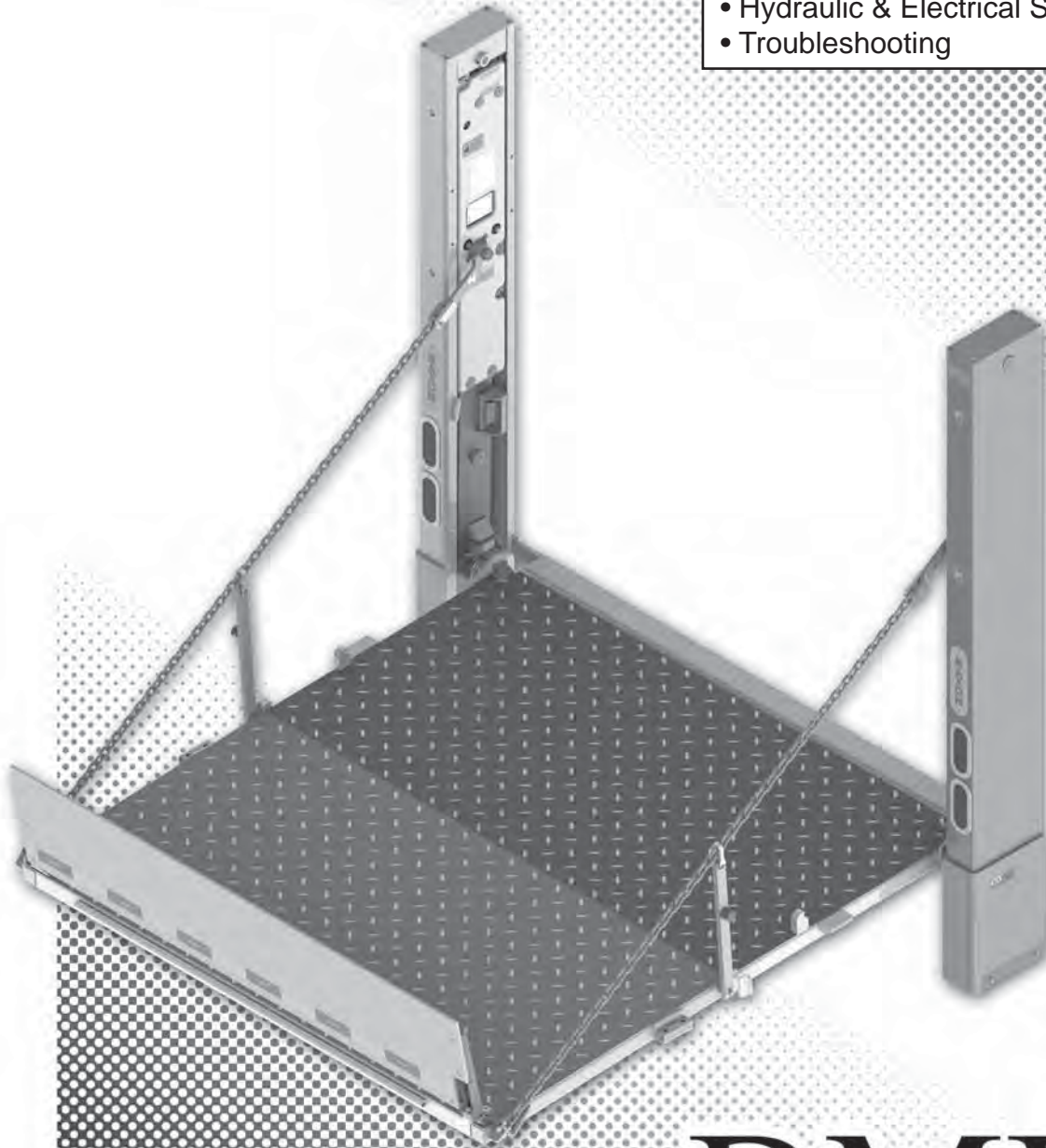

MAXON[®]
LIFT CORP.

BMR-A

MAINTENANCE MANUAL

MAXON[®]

LIFT CORP.

11921 Slauson Ave.
Santa Fe Springs, CA. 90670

CUSTOMER SERVICE:

TELEPHONE (562) 464-0099 TOLL FREE (800) 227-4116

FAX: (888) 771-7713

NOTE: For latest version of all Manuals (and replacements), download the
Manuals from Maxon's website at www.maxonlift.com.

WARRANTY/ RMA POLICY & PROCEDURE

LIFTGATE WARRANTY

Type of Warranty: Full Parts and Labor
Term of Warranty: Standard Liftgates - 2 years from ship date or 6,000 cycles
Premium Liftgates - 2 years from ship date or 10,000 cycles

This warranty shall not apply unless the product is installed, operated and maintained in accordance with MAXON Lift's specifications as set forth in MAXON Lift's Installation, Operation and Maintenance manuals. This warranty does not cover normal wear, maintenance or adjustments, damage or malfunction caused by improper handling, installation, abuse, misuse, negligence, or carelessness of operation. In addition, this warranty does not cover equipment that has had unauthorized modifications or alterations made to the product.

MAXON agrees to replace any components which are found to be defective during the first 2 years of service, and will reimburse for labor based on MAXON's Liftgate Warranty Flat Rate Schedule. (Copy of the Flat Rate is available at www.maxonlift.com.)

All warranty repairs must be performed by an authorized MAXON warranty facility. For any repairs that may exceed \$500, including parts and labor, MAXON's Technical Service Department must be notified and an "Authorization Number" obtained.

All claims for warranty must be received within 30 Days of the repair date, and include the following information:

1. Liftgate Model Number and Serial Number
2. The End User must be referenced on the claim
3. Detailed Description of Problem
4. Corrective Action Taken, and Date of Repair
5. Parts used for Repair, Including MAXON Part Number(s)
6. MAXON R.M.A. # and/or Authorization # if applicable (see below)
7. Person contacted at MAXON if applicable
8. Claim must show detailed information i.e. Labor rate and hours of work performed

Warranty claims can also be placed online at www.maxonlift.com. Online claims will be given priority processing.

All claims for warranty will be denied if paperwork has not been received or claim submitted via Maxon website for processing by MAXON's Warranty Department within 30 days of repair date.

All components may be subject to return for inspection, prior to the claim being processed. MAXON products may not be returned without prior written approval from MAXON's Technical Service Department. Returns must be accompanied by a copy of the original invoice or reference with original invoice number and are subject to a credit deduction to cover handling charges and any necessary reconditioning costs. **Unauthorized returns will be refused and will become the responsibility of the returnee.**

Any goods being returned to MAXON Lift must be pre-approved for return, and have the R.M.A. number written on the outside of the package in plain view, and returned freight prepaid. All returns are subject to a 15% handling charge if not accompanied by a detailed packing list. Returned parts are subject to no credit and returned back to the customer. Defective parts requested for return must be returned within 30 days of the claim date for consideration to:

MAXON Lift Corp.
10321 Greenleaf Ave., Santa Fe Springs, CA 90670
Attn: RMA#__

MAXON's warranty policy does not include the reimbursement for travel time, towing, vehicle rental, service calls, oil, batteries or loss of income due to downtime. Fabrication or use of non Maxon parts, which are available from MAXON, are also not covered.

MAXON's Flat Rate Labor Schedule takes into consideration the time required for diagnosis of a problem.

All Liftgates returned are subject to inspection and a 15% restocking fee. Any returned Liftgates or components that have been installed or not returned in new condition will be subject to an additional reworking charge, which will be based upon the labor and material cost required to return the Liftgate or component to new condition.

PURCHASE PART WARRANTY

Term of Warranty: 1 Year from Date of Purchase.

Type of Warranty: Part replacement only. MAXON will guarantee all returned genuine MAXON replacement parts upon receipt and inspection of parts and original invoice.

All warranty replacements parts will be sent out via ground freight. If a rush shipment is requested, all freight charges will be billed to the requesting party.

TABLE OF CONTENTS

WARNINGS	6
PERIODIC MAINTENANCE	8
DECAL - WELDING CAUTION	8
DECALS	10
MAXON BMR-A LIFTGATE	12
PREVENTATIVE MAINTENANCE CHECKLIST	12
PERIODIC MAINTENANCE CHECKS	13
BMRA LUBRICATION DIAGRAM.....	14
CHECKING HYDRAULIC FLUID	16
CHANGING HYDRAULIC FLUID	18
BLEEDING HYDRAULIC SYSTEM.....	19
PLATFORM FOLDING AND UNFOLDING SPEED ADJUSTMENT	20
ADJUSTMENT	22
PLATFORM CHAIN ADJUSTMENT	22
PLATFORM ADJUSTMENT	24
RETENTION RAMP ADJUSTMENT	25
REPLACING PARTS	26
CLOSING CYLINDER REPLACEMENT	26
LIFTING CYLINDER REPLACEMENT	27
RUNNER REPLACEMENT	30
HYDRAULIC SYSTEM DIAGRAMS	43
PUMP & MOTOR SOLENOID OPERATION.....	43
HYDRAULIC SCHEMATIC, SINGLE PUMP GRAVITY DOWN	44
HYDRAULIC SCHEMATIC, DUAL PUMP GRAVITY DOWN	45
GRAVITY DOWN HYDRAULIC LINES IDENTIFICATION	46
HYDRAULIC SCHEMATIC, SINGLE PUMP POWER DOWN	47

HYDRAULIC SCHEMATIC, DUAL PUMP POWER DOWN	48
POWER DOWN HYDRAULIC LINES IDENTIFICATION	49
ELECTRICAL SYSTEM DIAGRAMS	50
INTERCONNECTING ELECTRICAL SCHEMATIC.....	50
SINGLE PUMP BOX, GRAVITY DOWN.....	51
DUAL PUMP BOX, GRAVITY DOWN	52
SINGLE PUMP BOX, POWER DOWN	53
DUAL PUMP BOX, POWER DOWN	54
WIRING HARNESS CONNECTOR IDENTIFICATION	55
TROUBLESHOOTING	57
PLATFORM WILL NOT RAISE, MOTOR WILL NOT RUN.....	57
PLATFORM WILL NOT PICK UP RATED CAPACITY	58
PLATFORM RAISES HALFWAY & STOPS.....	59
PLATFORM RAISES AND LOWERS UNEVENLY	61
PLATFORM WILL NOT FOLD	64
PLATFORM WILL NOT UNFOLD.....	66
PUMP RELIEF VALVE PRESSURE SETTING	68
TROUBLESHOOTING - GRAVITY DOWN.....	69
PLATFORM WILL NOT RAISE, MOTOR RUNS	69
PLATFORM WILL NOT LOWER	70
PLATFORM LOWERS SLOWLY	72
TROUBLESHOOTING - POWER DOWN.....	74
PLATFORM WILL NOT RAISE, MOTOR RUNS	74
PLATFORM WILL NOT LOWER	76
PLATFORM LOWERS SLOWLY	78

Comply with the following **WARNINGS** and **SAFETY INSTRUCTIONS** while maintaining Liftgates. See Operation Manual for operating safety requirements.

⚠ WARNING

- Do not stand, or allow obstructions, under the platform when lowering the Liftgate. **Be sure your feet are clear of the Liftgate.**
- Keep fingers, hands, arms, legs, and feet clear of moving Liftgate parts (and platform edges) when operating the Liftgate.
- Correctly stow platform when not in use. Extended platforms could create a hazard for people and vehicles passing by.
- Disconnect Liftgate power cable from battery before repairing or servicing Liftgate.
- Remove all rings, watches and jewelry before doing any electrical work.
- If it is necessary to stand on the platform while maintaining the Liftgate, keep your feet and any objects clear of the inboard edge of the platform. Your feet or objects on the platform can become trapped between the platform and the Liftgate extension plate.
- Recommended practices for welding on steel parts are contained in the current **AWS (American Welding Society) D1.1 Structural Welding Code - Steel**. Damage to Liftgate and/or vehicle, and personal injury could result from welds that are done incorrectly.
- Recommended practices for welding on aluminum parts are contained in the current **AWS (American Welding Society) D1.2 Structural Welding Code - Aluminum**. Damage to Liftgate and/or vehicle, and personal injury could result from welds that are done incorrectly.
- Welding on galvanized parts gives off especially hazardous fumes. Comply with WARNING decal on the galvanized part (**FIG. 6-1**). To minimize hazard remove galvanizing from weld area, provide adequate ventilation, and wear suitable respirator.

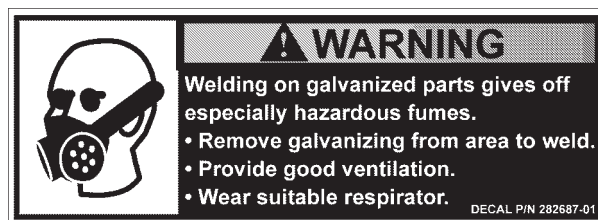

FIG. 6-1

MAXON[®]

11921 Slauson Ave. Santa Fe Springs, CA 90670 (800) 227-4116 FAX (888) 771-7713

SAFETY INSTRUCTIONS

- Read and understand the instructions in this **Maintenance Manual** before performing maintenance on the Liftgate.
- Before operating the Liftgate, read and understand the operating instructions in **Operation Manual**.
- Comply with all **WARNING** and instruction decals attached to the Liftgate.
- Keep decals clean and legible. If decals are illegible or missing, replace them. Free replacement decals are available from **Maxon Customer Service**.
- Consider the safety and location of bystanders and location of nearby objects when operating the Liftgate. Stand to one side of the platform while operating the Liftgate.
- Do not allow untrained persons or children to operate the Liftgate.
- Wear appropriate safety equipment such as protective eyeglasses, faceshield and clothing while performing maintenance on the Liftgate and handling the battery. Debris from drilling and contact with battery acid may injure unprotected eyes and skin.
- Be careful working by an automotive type battery. Make sure the work area is well ventilated and there are no flames or sparks near the battery. Never lay objects on the battery that can short the terminals together. If battery acid gets in your eyes, immediately seek first aid. If acid gets on your skin, immediately wash it off with soap and water.
- If an emergency situation arises (vehicle or Liftgate) while operating the Liftgate, release the control switch to stop the Liftgate.
- A correctly installed Liftgate operates smoothly and reasonably quiet. The only noticeable noise during operation comes from the power unit while the platform is raised. Listen for scraping, grating and binding noises and correct the problem before continuing to operate Liftgate.
- Use only **Maxon Authorized Parts** for replacement parts. Provide Liftgate model and serial number information with your parts order. Order replacement parts from:

MAXON LIFT CORP. Customer Service
11921 Slauson Ave., Santa Fe Springs, CA 90670

Online: www.maxonlift.com
Express Parts Ordering: Phone (800) 227-4116 ext. 4345
Email: Ask your Customer Service representative

PERIODIC MAINTENANCE

DECAL - WELDING CAUTION

CAUTION

Comply with welding CAUTION decals on Liftgate runners.

NOTE: See following pages to find the other decals on Liftgate.

CAUTION

Electrical components and metal parts on this liftgate can be severely damaged by connecting an electric welder to liftgate at the wrong place. To prevent damage, always connect ground lead directly to the component being welded (e.g. runner, column, platform) and as close to the weld as possible.

P/N 260293

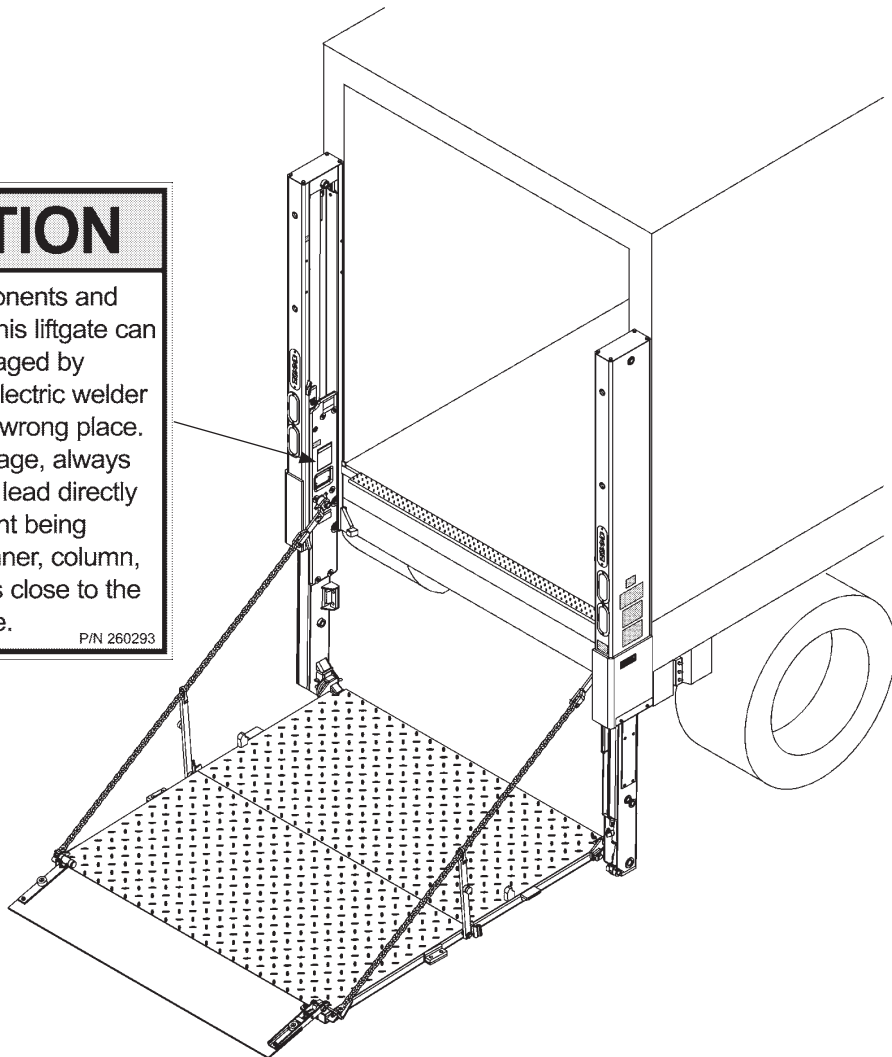

FIG. 8-1

MAXON[®]

11921 Slauson Ave. Santa Fe Springs, CA. 90670 (800) 227-4116 FAX (888) 771-7713

THIS PAGE INTENTIONALLY LEFT BLANK

PERIODIC MAINTENANCE DECALS

NOTE: Ensure there is no residue, dirt, or corrosion where decals are attached.
If necessary, clean surface before attaching decals.



**CAUTION DECAL (2 PLACES)
(LABEL IS PART OF PLASTIC COVER)
P/N 266508-01**

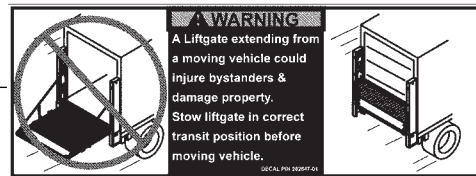

**STOW WARNING DECAL
P/N 282847-01**

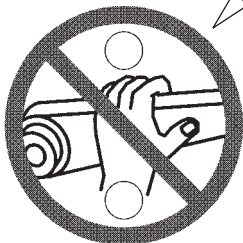
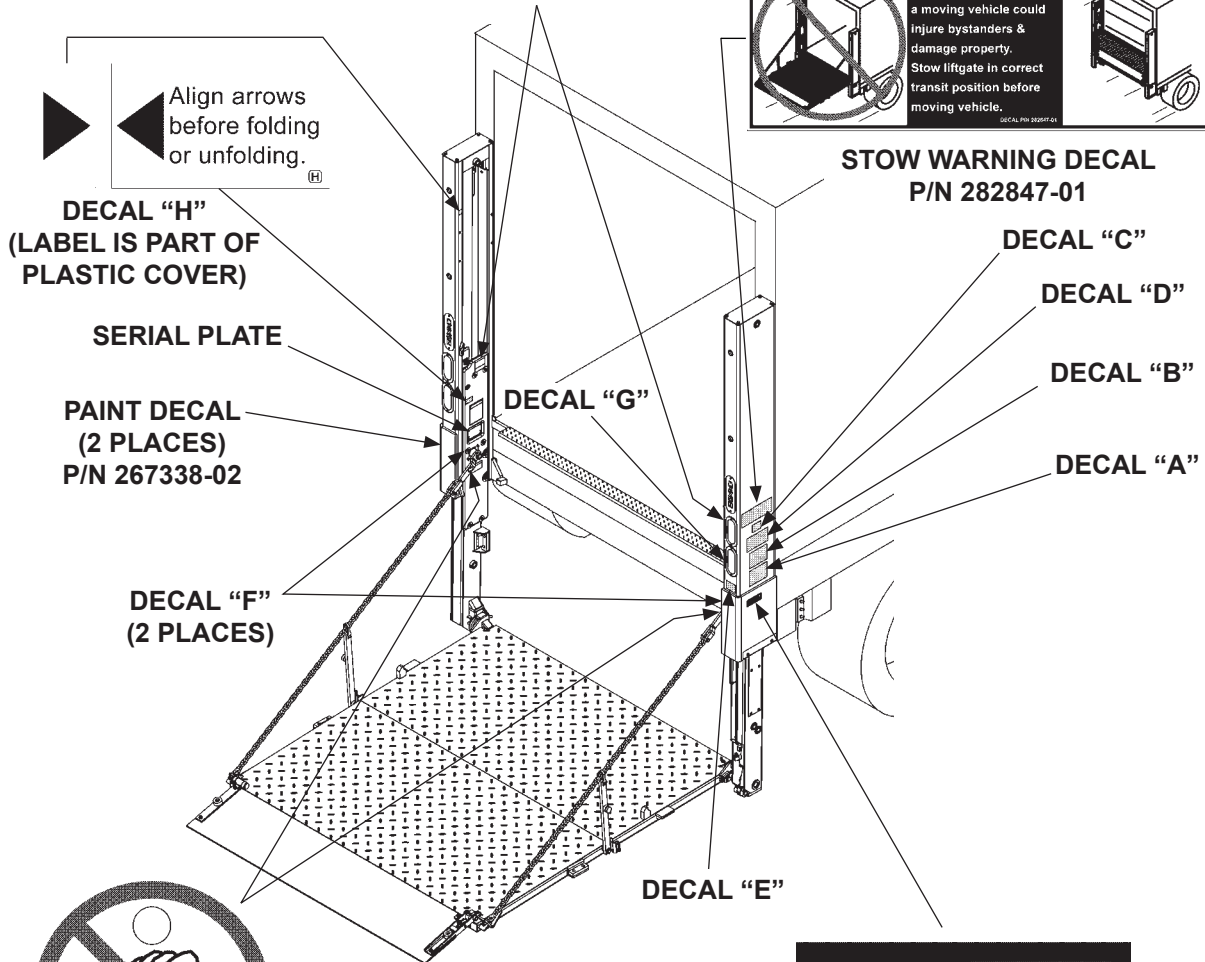

**KEEP HANDS CLEAR
(2 PLACES)
P/N 260009**



**PAINT DECAL
(BMR-A, 2 PLACES)
P/N 267338-01**

FIG. 10-1

SAFETY INSTRUCTIONS

Read all decals and operation manual before operating liftgate.

1. Do not use liftgate unless you have been properly instructed and have read, and are familiar with, the operating instructions.
2. Be certain vehicle is properly and securely braked before using the liftgate.
3. Always inspect this liftgate for maintenance or damage before using it. Do not use liftgate if it shows any sign of damage or improper maintenance.
4. Do not overload
5. Make certain the area in which the platform will open and close is clear before opening or closing the platform.
6. Make certain platform area, including the area in which loads may fall from platform, is clear before and at all times during operation of liftgate.
7. This liftgate is intended for loading and unloading of cargo only. Do not use this liftgate for anything but its intended use.

(A)

WARNING

Read this information carefully.

- Improper operation of this Liftgate can result in serious personal injury. If you do not have a copy of the operating instructions, please obtain them from your employer, distributor, or lessor before you attempt to operate Liftgate.
- If there are signs of improper maintenance, damage to vital parts, or slippery platform surface, do not use the Liftgate until these problems have been corrected.
- If you are using a pallet jack, be sure it can be maneuvered safely.
- Do not operate a forklift on the platform.
- Do not allow any part of yours or your helper's body to be placed under, within, or around any portion of the moving Liftgate, or its mechanisms, or in a position that would trap them between the platform and the ground or truck when the Liftgate is operated.
- If a helper is riding the platform with you, make sure you are both doing so safely and that you are not in danger of coming in contact with any moving or potentially moving obstacles.
- **USE GOOD COMMON SENSE**
- If load appears to be unsafe, do not lift or lower it.

For a free copy of other manuals that pertain to this model Liftgate, please visit our website at www.maxonlift.com or call Customer Service at (800) 227-4116.

(B)

THE MAXIMUM CAPACITY OF THIS LIFT IS

___ LB [___ KG]

WHEN THE LOAD IS CENTERED ON THE LOAD CARRYING PLATFORM

(C)

(REFER TO TABLE 11-1)

WARNING



Liftgate hazards can result in crushing or falling.

Keep hands and feet clear of pinch points.

If riding liftgate, make sure load is stable and footing is solid.

(D)

Read and understand all instructions and WARNINGS before use.

CAUTION

Always stand clear of platform area.

(E)

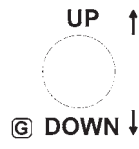

CAUTION

Do not grease columns.

(F)

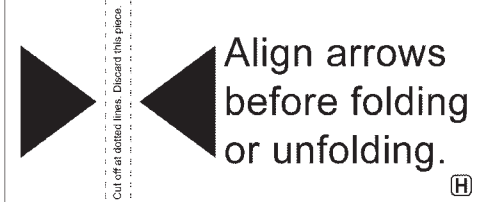

(H)

(LABEL IS PART OF PLASTIC COVER)

(LABEL IS PART OF PLASTIC COVER)

DECAL SHEET
FIG. 11-1

MODEL	ORDER P/N	DECAL "C"
BMRA-35	268309-01	3500 LBS. [1600 KG]
BMRA-44	268309-02	4400 LBS. [2000 KG]
BMRA-55	268309-03	5500 LBS. [2500 KG]
BMRA-66	268309-04	6600 LBS. [3000 KG]

DECAL SHEET PART NUMBERS
TABLE 11-1

FIG. 11-1

PERIODIC MAINTENANCE

MAXON BMR-A LIFTGATE

PREVENTATIVE MAINTENANCE CHECKLIST

PM Interval: Quarterly / Annual

Date: ___ / ___ / ___

Equipment: _____

W/O # _____

Location: _____

Mechanic: _____

Serial # _____

Model # _____

Check Appropriate Box. " " "

MAXON Quarterly Liftgate PM Procedures

Satisfactory	Repair Required	Corrected		
			1	Check your company's maintenance records to verify when quarterly and annual PM's are due.
			2	Check for oil leaks: cylinders, fittings, hoses, valves, oil filter and fittings inside of pump box.
			3	Check for damage: bent ramps, platform, columns, runners & hydraulic tubes.
			4	Check for loose or missing nuts, bolts, covers, roll pins, screws and pins.
			5	Check for cracked welds: columns, runners, platform, chain arms, pump box and door frame.
			6	Check platform lowering speed: Range is 8-22 seconds BMRA-35/-44 or 12-27 seconds BMRA-55/66 with unloaded platform. Check "D" valves for proper operation
			7	Check platform pins and couplers. Check roller assemblies
			8	Check platform raising speed: Range is 9-21 seconds BMRA-35/-44 or 13-26 seconds BMRA-55/-66 with unloaded platform
			9	Check open and close speed: Range is 3-8 seconds in either direction. Adjust if necessary
			10	Check platform pins and couplers. Check roller assemblies on runners.
			11	Check switches, circuit breaker & wiring connections on Liftgate as well as inside pump box. Also check that ground strap connections are tight.
			12	Check gear pump for unusual noise (i.e. squealing or excessive RPM).
			13	Check oil level with platform stowed. Refer to oil decal inside pump cover. The sight glass should be half full. Check oil for contamination. Change if needed.
			14	Check batteries: load test, corrosion, cables, hold downs and water level.
			15	Dual pump boxes: Please switch the selector switch to opposite pump at each PM.
			16	Check platform chains for wear each time maintenance is performed.
			17	Check operation of cart stop ramps (if equipped).
			18	Check all charging and ground cable connections
			19	Pump EP synthetic grease in each lube fitting at 2 platform pivots and the 2 roller axels on the 4 tandems (if equipped with fittings). Wipe away grease seepage. Ensure each of the tandem rollers is clean and free of grease.
			20	Follow your company's guidelines for completing PM stickers and maintenance records for the Liftgate.

For more detailed information, please refer to the applicable sections in this Maintenance Manual and the separate Parts Manual. Use only genuine Maxon replacement parts for all repairs.

MAXON Annual Liftgate PM Procedures

Satisfactory	Repair Required	Corrected	21	Replace spin-on filter in pump box. Change hydraulic fluid if contaminated.
Satisfactory	Repair Required	Corrected	22	Inspect wear on slide pads, on the RH and LH runners.

TABLE 12-1

PERIODIC MAINTENANCE CHECKS

⚠ WARNING

Never operate the Liftgate if parts are loose or missing.

NOTE: Photocopy the **PM CHECKLIST** on the preceding page to help keep track of periodic maintenance on the Liftgate. Keep completed form with maintenance records.

NOTE: When replacing parts, refer to Parts Manual for genuine MAXON replacement parts.

Annually

- Change spin-on oil filter.
- Inspect for wear on slide pads on the RH & LH runners.

Quarterly

Check the hydraulic fluid level in the pump reservoir. Refer to the **CHECKING HYDRAULIC FLUID** procedure in the **PERIODIC MAINTENANCE** section.

- If hydraulic fluid appears contaminated, refer to the **CHANGING HYDRAULIC FLUID** procedure on following page.
- Keep track of the grade of hydraulic fluid in the pump reservoir. Never mix two different grades of fluid.
- Check pump box cover seal. Replace seal if damaged.
- Check hoses and fittings for chaffing and fluid leaks. Replace if necessary.
- Check electrical wiring for chaffing and make sure wiring connections are tight and free of corrosion. **MAXON** recommends using dielectric grease on all electrical connections.
- Check that all **WARNING** and **instruction decals** are in place and legible.
- Check that all roll pins are in place and protrude evenly from both sides of hinge pin collar. Replace roll pins if necessary.
- Check each end of the two platform chains to make sure they are fastened properly.
- Check for worn out links on each of the two platform chains.
- Pump EP synthetic grease in fitting on 2 platform pivots and roller axels on 4 tandems.

CAUTION

Damaged cylinder seals and contaminated hydraulic fluid can result from painting the polished portion of the cylinder rod. To prevent damage, protect the exposed polished portion of the cylinder rod while painting.

- Check for rust and oily surfaces on Liftgate. If there is rust or oil on the Liftgate, clean it off. Touch up the paint where bare metal is showing. **MAXON** recommends using the aluminum primer touchup paint kit, P/N 908134-01.

PERIODIC MAINTENANCE

PERIODIC MAINTENANCE CHECKS - Continued

BMRA LUBRICATION DIAGRAM

NOTE: Lube fittings are shown for the tandem roller axels on the LH runner and the pivot on the LH side of platform. There are also lube fittings on the tandem roller axels for the RH runner and the pivot on the RH side of the platform. Refer to the **PERIODIC MAINTENANCE CHECKS** and **PREVENTATIVE MAINTENANCE CHECKLIST** for the recommended grease and maintenance interval.

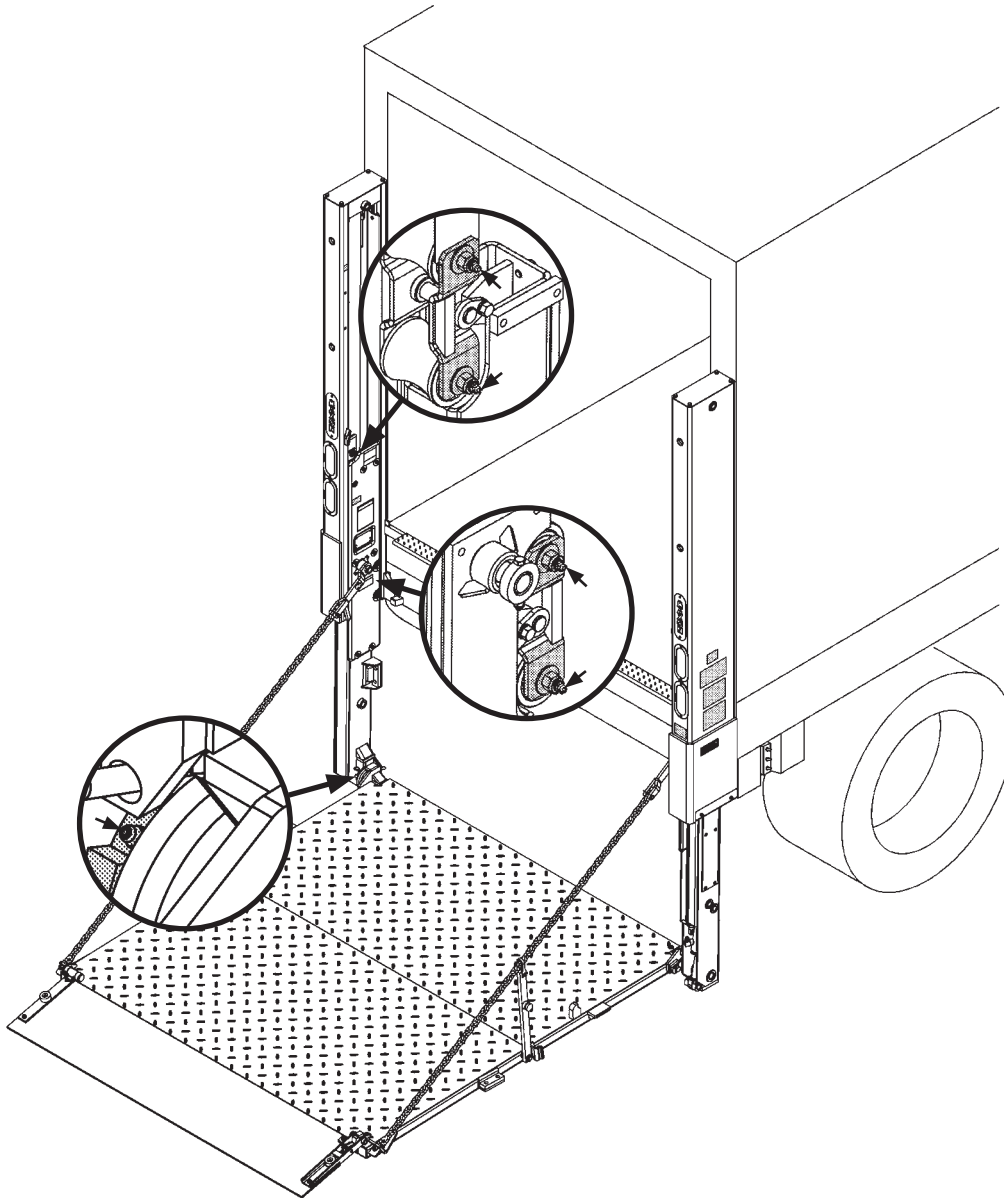

FIG. 14-1

MAXON[®]

11921 Slauson Ave. Santa Fe Springs, CA. 90670 (800) 227-4116 FAX (888) 771-7713

THIS PAGE INTENTIONALLY LEFT BLANK.

CHECKING HYDRAULIC FLUID

CAUTION

Keep dirt, water and other contaminants from entering the hydraulic system. Before opening the hydraulic fluid reservoir filler cap, drain plug and hydraulic lines, clean up contaminants that can get in the openings. Also, protect the openings from accidental contamination. Never mix synthetic fluids with conventional hydraulic fluids. Hydraulic system must be purged if the fluids are mixed.

NOTE: Exxon Univis HVI-13 hydraulic fluid is recommended for operating temperatures of -40 to $+120^{\circ}$ F. Refer to decal in pump box. The ISO-15 fluids in TABLE 17-1 may be used if the recommended fluids are unavailable. If necessary, the ISO-32 fluids in TABLE 17-2 may be used where ordinary seasonal temperatures are near $+100^{\circ}$ F or higher.

NOTE: If the hydraulic fluid in the reservoir is contaminated, do the **CHANGING HYDRAULIC FLUID** procedure in this section.

1. Stow the platform in the up position. Refer to **Operation Manual** for instructions.
2. Open the pump box cover to gain access to sight glass and filler cap (**FIG. 16-1**).

NOTE: Information for checking hydraulic fluid level is also shown on a decal inside the pump box cover.

3. Check the hydraulic fluid level in sight glass (**FIG. 16-1**). Hydraulic fluid level should be at the center of sight glass. If fluid is below the center, add fluid to the reservoir as follows. Remove filler cap (**FIG. 16-1**). Add the correct grade of hydraulic fluid to reservoir until the level is at the center of the sight glass (**FIG. 16-1**).

4. Reinstall filler cap (**FIG. 16-1**) and close the pump box cover.

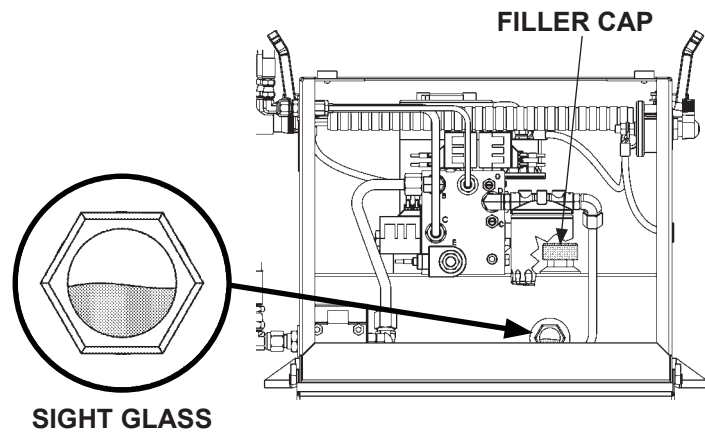

CHECKING HYDRAULIC FLUID LEVEL
FIG. 16-1

ISO-15 OR MIL-H-5606 TYPE HYDRAULIC OIL	
BRAND	PART NUMBER
AMSOIL	AWF-05
CHEVRON	FLUID A, AW-MV-15
KENDALL	GLACIAL BLU
SHELL	TELLUS S2 V15
MOBIL	DTE-11M
ROSEMEAD	THS FLUID 17111

TABLE 17-1

ISO-32 HYDRAULIC OIL	
BRAND	PART NUMBER
AMSOIL	AWH-05
CHEVRON	HIPERSYN 32
KENDALL	GOLDEN MV
SHELL	TELLUS S2 V32
EXXON	UNIVIS N-32
MOBIL	DTE-13M, DTE-24, HYDRAULIC OIL-13

TABLE 17-2

PERIODIC MAINTENANCE CHANGING HYDRAULIC FLUID

CAUTION

Keep dirt, water and other contaminants from entering the hydraulic system. Before opening the hydraulic fluid reservoir filler cap, drain plug and hydraulic lines, clean up contaminants that can get in the openings. Also, protect the openings from accidental contamination. Never mix synthetic fluids with conventional hydraulic fluids. Hydraulic system must be purged if the fluids are mixed.

NOTE: Exxon Univis HVI-13 hydraulic fluid is recommended for operating temperatures of -40 to $+120^{\circ}$ F. Refer to decal in pump box. The ISO-15 fluids in TABLE 17-1 may be used if the recommended fluids are unavailable. If necessary, the ISO-32 fluids in TABLE 17-2 may be used where ordinary seasonal temperatures are near $+100^{\circ}$ F or higher.

GRAVITY DOWN LIFTGATES

1. Place empty 5 gallon bucket under drain plug.
2. Open and lower platform. Remove the drain plug (FIG. 18-1). Drain hydraulic fluid from system. Reinstall drain plug.
3. Remove filler cap (FIG. 18-1). Refill reservoir until hydraulic fluid level is at the center of sight glass (FIG. 18-1).
4. Reinstall filler cap (FIG. 18-2).

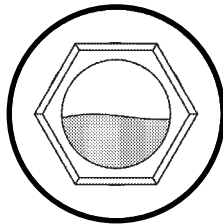

SIGHT GLASS

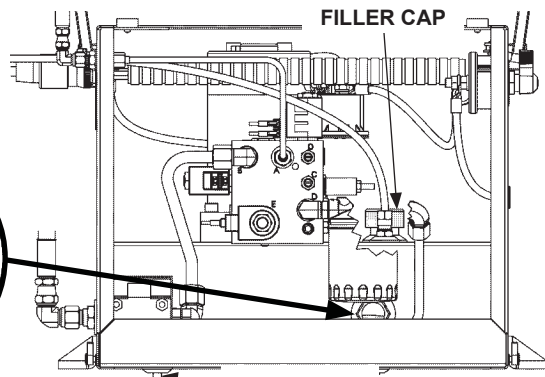

SINGLE PUMP BOX
FIG. 18-1

POWER DOWN LIFTGATES

1. Place empty 5 gallon bucket under drain plug.
2. Open and raise platform to vehicle bed height. Remove the drain plug (FIG. 18-1).
3. Disconnect the drive wire (FIG. 18-2) from motor solenoid. Lower the platform while draining hydraulic fluid from system. Reinstall drain plug. Reconnect the drive wire to motor solenoid.
4. Remove filler cap (FIG. 18-1). Refill reservoir until hydraulic fluid level is at the center of sight glass (FIG. 18-1).
5. Raise platform to vehicle bed height. Check hydraulic fluid again and, if needed, add more hydraulic fluid until level is at the center of sight glass (FIG. 18-1).
6. Reinstall filler cap (FIG. 18-1).

DRIVE WIRE
(SINGLE PUMP - WHITE)
(DUAL, PUMP 1 - BLK+WHT STRIPE)
(DUAL, PUMP 2 - GRN+WHT STRIPE)

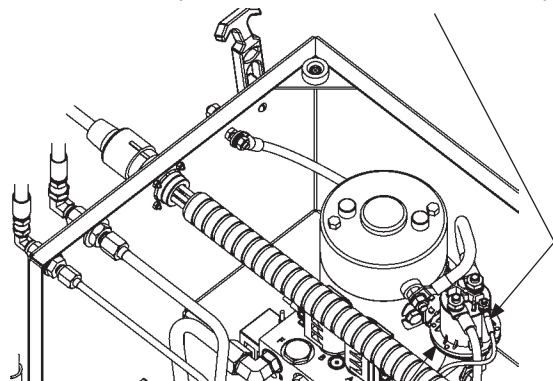

MOTOR SOLENOID
SINGLE PD PUMP BOX
FIG. 18-2

BLEEDING HYDRAULIC SYSTEM

NOTE: Perform this procedure at a place where Liftgate platform can be lowered to lowest point of travel. Get a helper to operate Liftgate control switch.

1. Use **UP/DOWN** toggle switch to lower the opened platform to the ground.
2. Loosen, but do not disconnect, the nut connecting hydraulic line to fitting on pressure compensated flow control valve (**FIG. 19-1**) at top of both cylinders.

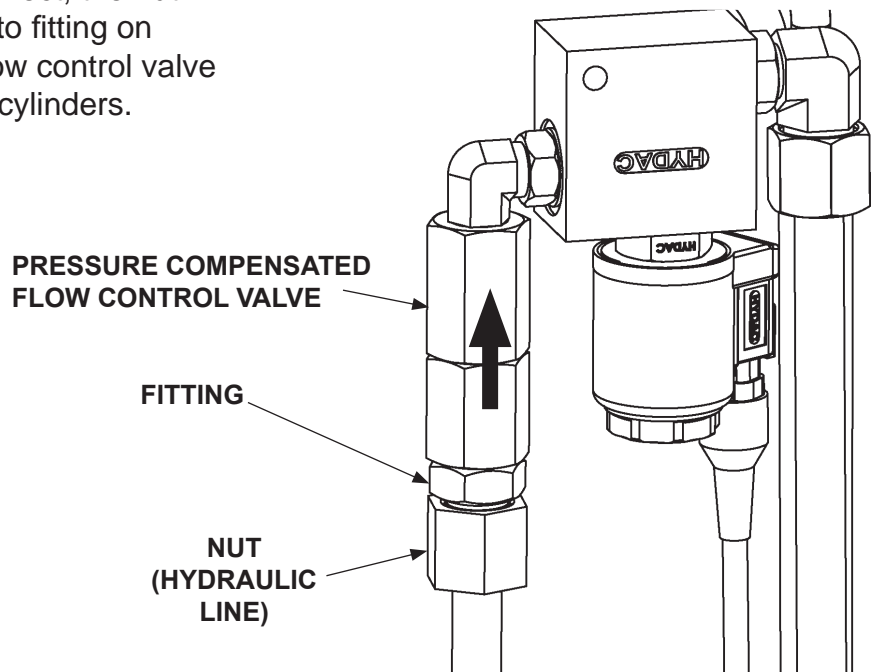

FIG. 19-1

3. Set the **UP/DOWN** switch on the RH runner in the **UP** position for approximately one second and then release the switch. Wait ten seconds and then switch to **UP** and release. Repeat this step until there is no air bubbling from the loosened line fittings.
4. Tighten nut on hydraulic line (**FIG. 19-1**).
5. Use **UP/DOWN** toggle switch to raise and lower the platform to make sure the Liftgate operates correctly.

PERIODIC MAINTENANCE

PLATFORM FOLDING AND UNFOLDING SPEED ADJUSTMENT

1. The speed settings for the closing cylinder are regulated by the pressure relief needle valves located on the pump manifold (FIGS. 20-1 and 20-2). One valve is marked "O" (open platform) and the other is marked "C" (close platform).

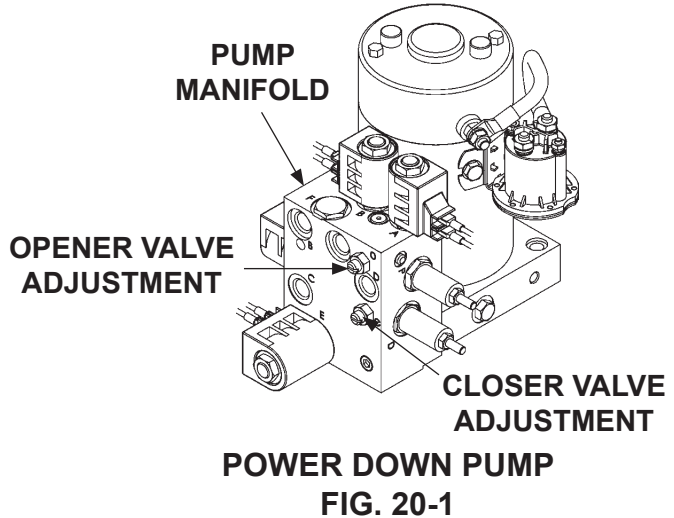

2. To decrease platform opening speed, turn opener valve adjustment clockwise (FIGS. 20-1 and 20-2). To increase platform opening speed, turn opener valve adjustment counter-clockwise (FIGS. 20-1 and 20-2).

3. To increase platform closing speed, turn closer valve adjustment clockwise (FIGS. 20-1 and 20-2). To decrease platform closing speed, turn closer valve adjustment counter-clockwise (FIGS. 20-1 and 20-2).

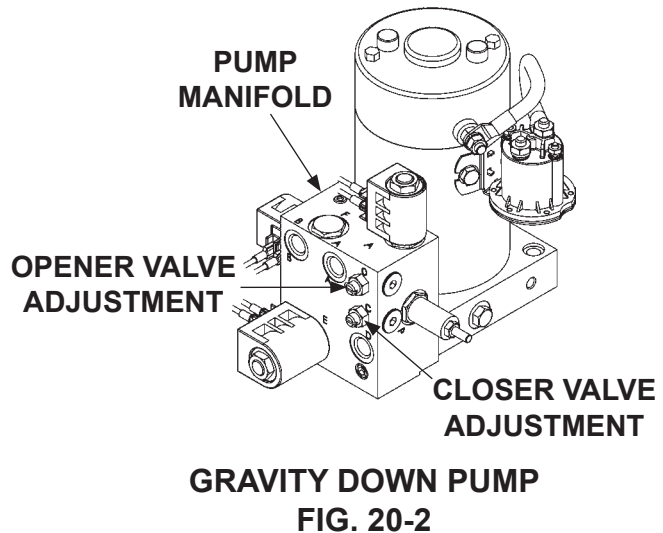

MAXON[®]

11921 Slauson Ave. Santa Fe Springs, CA. 90670 (800) 227-4116 FAX (888) 771-7713

THIS PAGE INTENTIONALLY LEFT BLANK.

ADJUSTMENT PLATFORM CHAIN ADJUSTMENT

1. Lower the platform to ground level. Check if tip of the flipover and bottom of the runners touch the ground at the same time (FIG. 22-1).

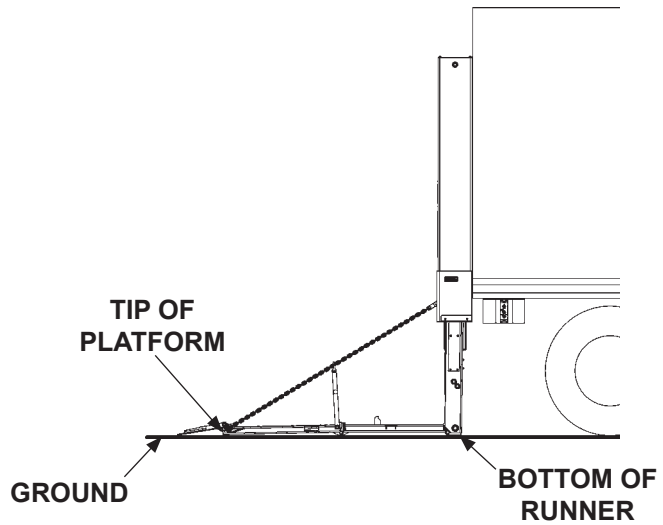

**TIP AND RUNNER TOUCHING GROUND
FIG. 22-1**

2. If the bottom of the runners are off the ground, measure the distance "H1" (FIG. 22-2) from the ground to the bottom of the runners.

- Adjustment is not required if distance "H1" is 1" or less.
- If distance "H1" is more than 1", refer to the steps that follow to adjust the platform chains.

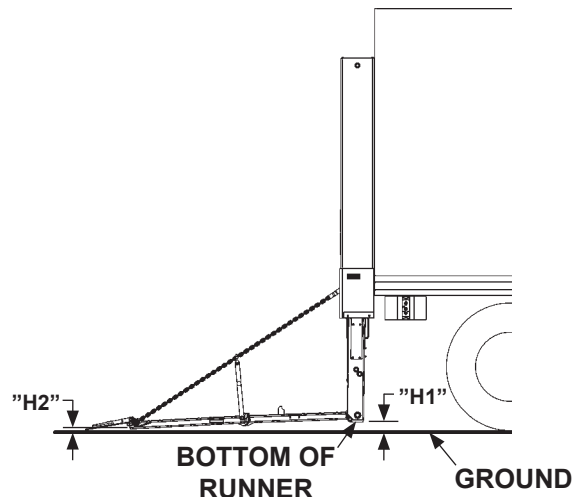

**RUNNERS NOT TOUCHING
FIG. 22-2**

3. Refer to measured distance "H1" at the runners and TABLE 22-1. Note the method(s) that will be required to raise the tip of platform (or retention ramp) the expected distance.

MEASURED "H1" (AT RUNNER)	ADJUSTMENT METHODS (● REQUIRED FOR EXPECTED RISE AT TIP)		EXPECTED RISE "H2" (AT TIP)
	REMOVE 1 LINK OF BOTH CHAINS (RAISES TIP 1-1/2")	REMOVE 2 LINKS OF BOTH CHAINS (RAISES TIP 3")	
1" - 2-1/4"	-	-	0" - 1-1/4"
2-1/2" - 3-3/4"	●		1-1/2" - 2-3/4"
4"	●	●	3" - 4"

TABLE 22-1

4. Raise platform enough to remove supports. Then, lower platform to the ground (**FIG. 23-1**). Tip of flipover and runners should touch the ground at the same time as shown in **FIG. 23-1**. If necessary, repeat instructions 3 through 5 until tip of platform and runners touch ground at the same time.

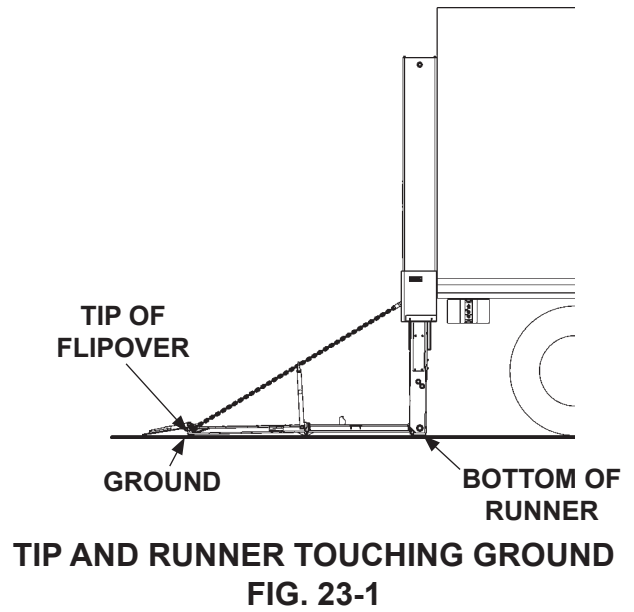

PLATFORM ADJUSTMENT

1. Ensure aluminum platform is completely unfolded (**FIG. 24-1**). Use long straight edge to determine if top surface of platform is flush with top surface of flipover as shown in **FIG. 24-1**.

NOTE: Recommend turning bolt in 60° increments so flats of the adjuster bolt are parallel to vertical surface of side plates.

2. If flipover requires adjustment, fold platform enough to gain access to adjustment bolt on each side of platform (**FIG. 24-2**). Next, loosen locking nut for each adjuster bolt (**FIG. 24-2**). Then, alternately turn each bolt clockwise to raise tip of flipover or counter-clockwise to lower tip of flipover. Repeat 1 to check. When platform and flipover are flush, torque both locking nuts to **192 lb-ft.**

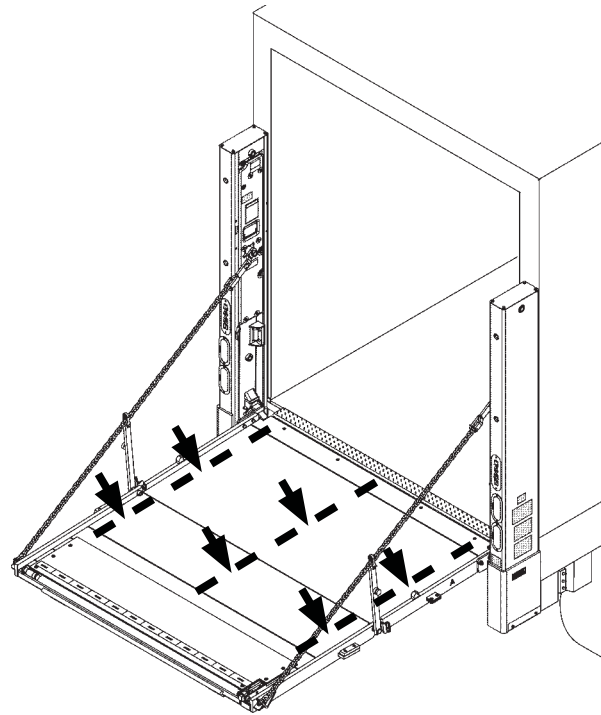

ARROWS INDICATE WHERE TO CHECK IF PLATFORM & FLIPOVER ARE FLUSH
FIG. 24-1

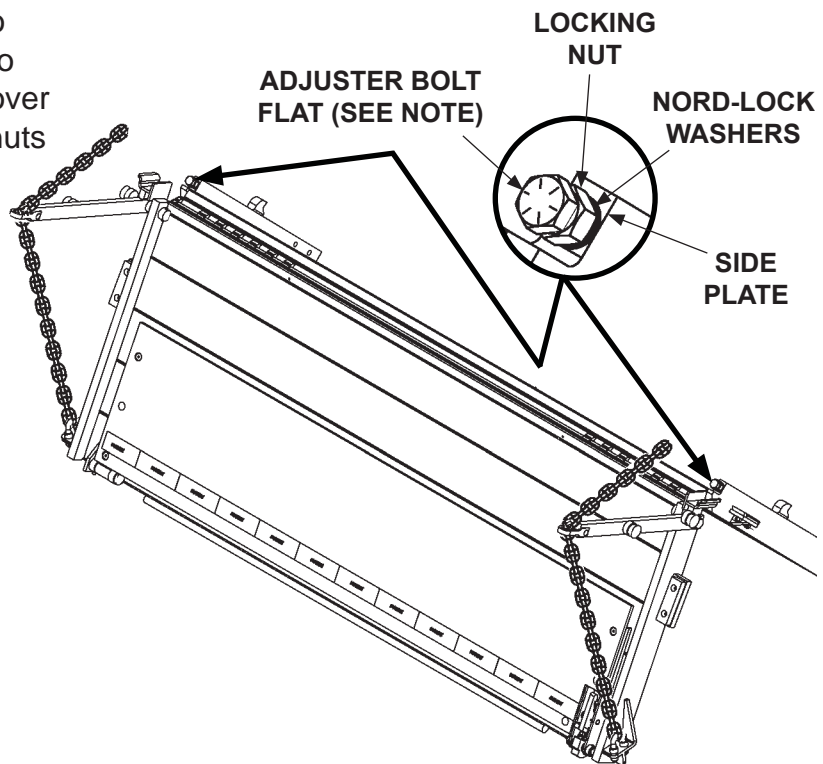

PLATFORM ADJUSTMENT BOLT
FIG. 24-2

RETENTION RAMP ADJUSTMENT

1. Unfold and lower platform to the ground. Refer to operating instructions in the **Operation Manual**.
2. Push down on ramp (**FIG. 25-2A**). If gap exist between locking cam and bolt (**FIG. 25-2B**), turn bolt counterclockwise until it touches the locking cam.
3. Push on lock to ensure it releases (**FIG. 25-2A**). If lock does not release, turn bolt clockwise until lock releases.
3. Once bolt is at the correct distance, tighten nut (**FIG. 25-2B**).

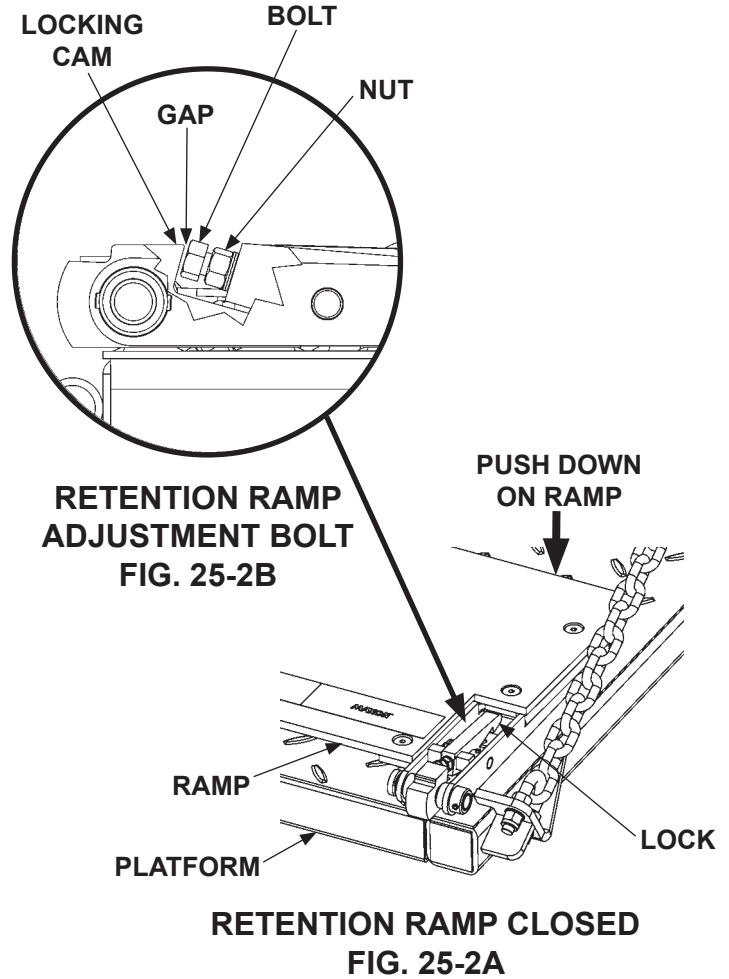

REPLACING PARTS CLOSING CYLINDER REPLACEMENT

1. **UNFOLD** the platform. Lower the platform (**DOWN**) to comfortable height for work. Upper pin must be lower than the bottom of the column (see **FIG. 26-1**).
2. Disconnect the hydraulic hose from lower end of cylinder (**FIG. 26-2**). Plug hose to prevent spills.
3. Remove the lower roll pin from inside coupling (**FIG. 26-2**) and then remove lower pin.
4. Remove the upper roll pin (**FIG. 26-2**) from the runner and then remove the upper pin.
5. Remove cylinder from runner (**FIG. 26-2**).
6. Place replacement cylinder in the correct position as shown in **FIG. 26-2**.
7. Install upper pin (**FIG. 26-2**) and roll pin in upper end of cylinder and runner.
8. Install lower pin (**FIG. 26-2**) and roll pin in lower end of cylinder and inside coupling.
9. Reconnect hydraulic hose to cylinder (**FIG. 26-2**).

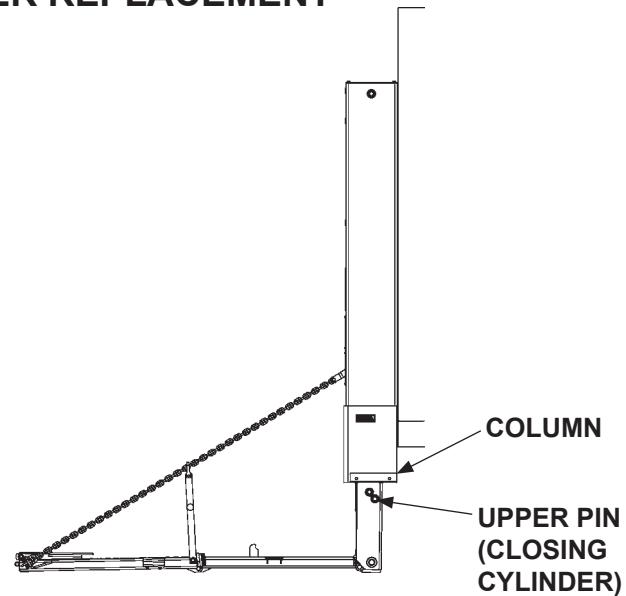

FIG. 26-1

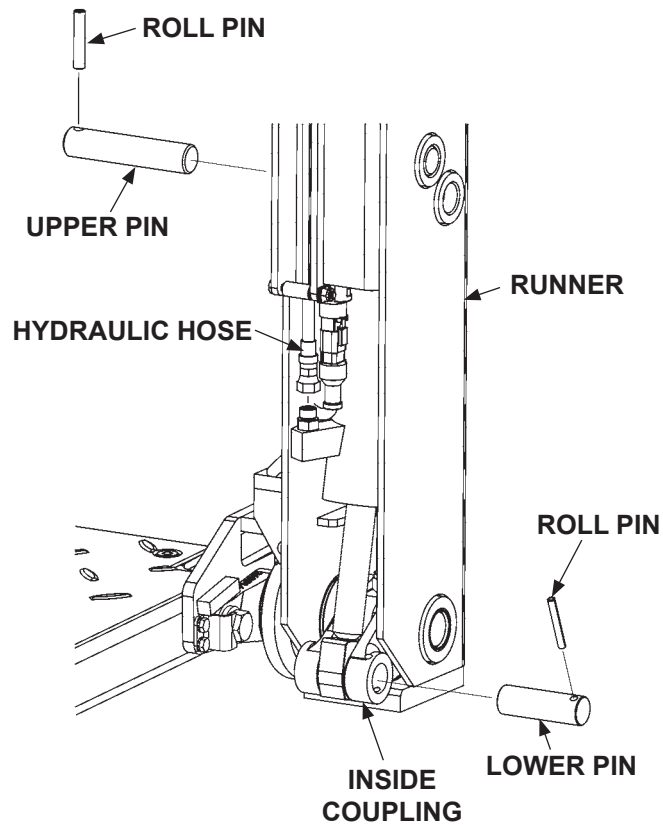

FIG. 26-2

REPLACING PARTS

LIFTING CYLINDER REPLACEMENT

⚠ WARNING

Use floor jack and jack stands to support platform while performing this procedure.

CAUTION

Keep dirt, water and other contaminants from entering the hydraulic system. Before opening the hydraulic fluid reservoir filler cap, drain plug and hydraulic lines, clean up contaminants that can get in the openings. Also, protect the openings from accidental contamination.

NOTE: Refer to **Operation Manual** for instructions to operate Liftgate.

1. Raise the open platform about 20" above the ground. Then, place jack stands under the platform (**FIG. 27-1**) for support. Measure and record the distance between the centers of upper and lower cylinder pins. Keep measurement for reference when installing new cylinder.

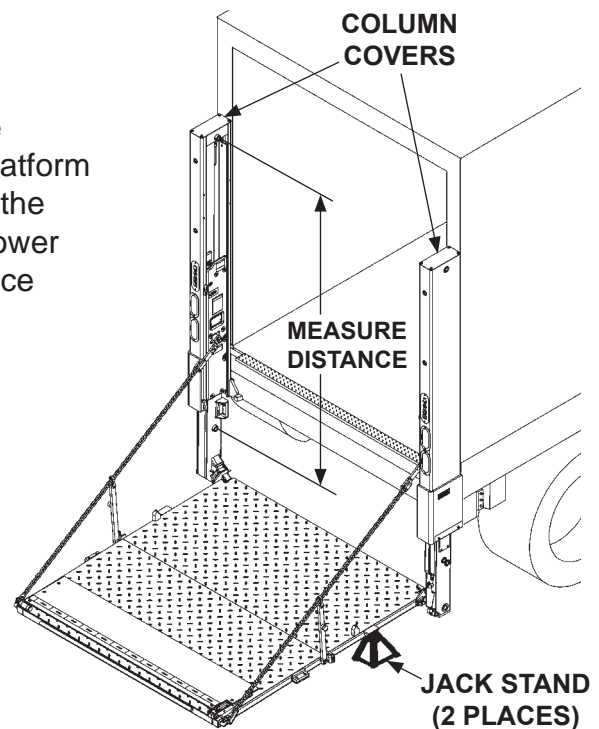

FIG. 27-1

2. Remove cover from the top of the column (**FIG. 27-1**). Put empty 3 gallon container under column for hydraulic fluid.

3. Loosen and disengage nut #1 (**FIG. 27-2**) from elbow on top of cylinder. Remove elbow from cylinder (**FIG. 27-2**). Keep elbow to reinstall on new cylinder. Loosen and disengage nut #2 from fitting on bottom of flow control valve.

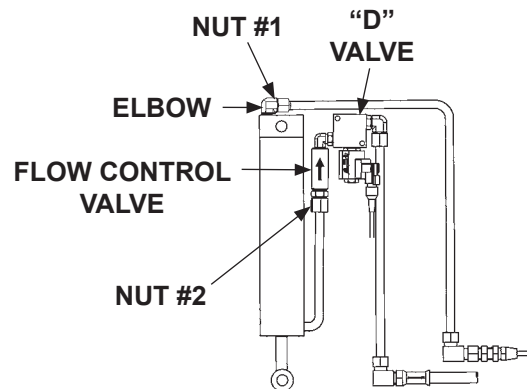
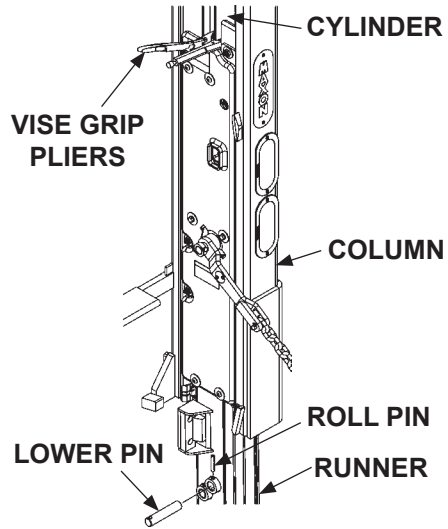

FIG. 27-2

REPLACING PARTS

LIFTING CYLINDER REPLACEMENT - Continued

4. Remove lower roll pin & lower pin from lifting cylinder (**FIG. 28-1**). Then, clamp large, curved vise grip pliers around the cylinder just above the top of the runner as shown in **FIG. 28-1**.



**SECURING CYLINDER
FIG. 28-1**

5. Remove upper roll pin & upper pin from cylinder (**FIG. 28-2**). Lift cylinder about 4" above top of column.

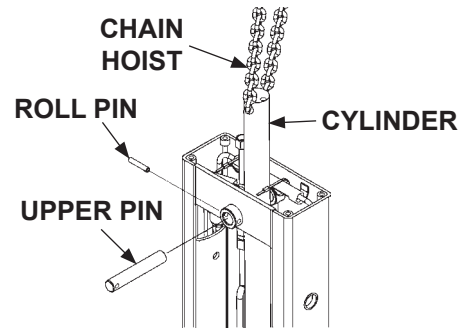

**REMOVING CYLINDER
FIG. 28-2**

6. Remove cylinder from column as follows. Attach a chain hoist or equivalent lifting device to support the upper end of cylinder (**FIG. 28-2**). Remove vise grip pliers from cylinder. Hoist the cylinder until it clears the top of column. Then lower cylinder to the ground.

! CAUTION
Move old cylinder out of the way to prevent possible trip hazard.

7. Remove plastic plugs from line fittings on new cylinder. Then fasten a long clean extension hose, with #8 face seal connector, to lifting line as shown in **FIG. 28-3**.

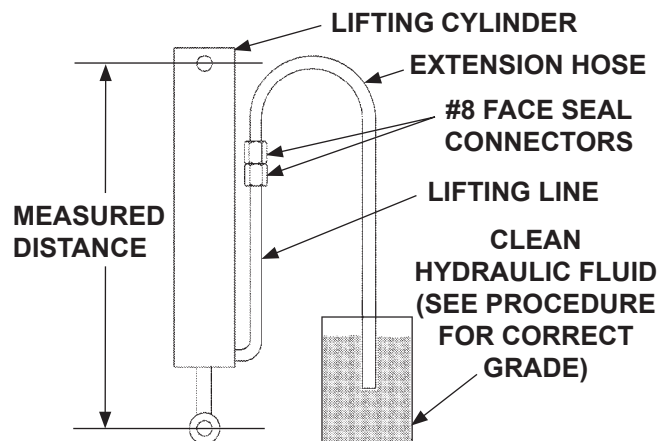

**PREPARING NEW CYLINDER
FOR INSTALLATION
FIG. 28-3**

8. Fully extend cylinder rod. Then place open end of hose in gallon container of clean hydraulic fluid. Next, push cylinder rod into cylinder until distance measured between butt-end and rod-end pin bores, is the same as distance recorded in **Step 1**. Replace plastic plug on top of cylinder housing.

9. To help remove air from rod end of housing, position cylinder on its side with the lifting line on top (FIG. 29-1). Then slowly return cylinder to vertical position (FIG. 29-2).

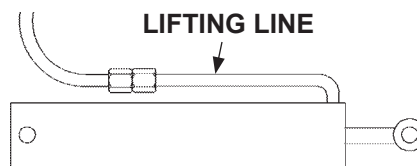

**CYLINDER POSITIONED ON SIDE
FIG. 29-1**

10. Remove extension hose and plug the lifting line (FIG. 29-2).

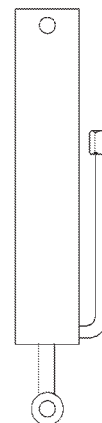

**CYLINDER WITH HOSE REMOVED
FIG. 29-2**

NOTE: Before installing a new cylinder, get a helper. Have the helper look through square inspection hole on back of runner while cylinder is lowered. The helper can inform installer when rod end of cylinder is lined up with lower pin.

NOTE: To install cylinder correctly, make sure hydraulic lines on cylinder are facing the vehicle body.

11. To install new Lifting cylinder, reverse **Steps 6, 5, 4, 3, and 2.**
12. Raise platform enough to remove jack stands (FIG. 29-3). Then lower platform all the way. Pressurize hydraulic system by pushing control switch to **UP** position. Release switch when platform is raised to bed height.

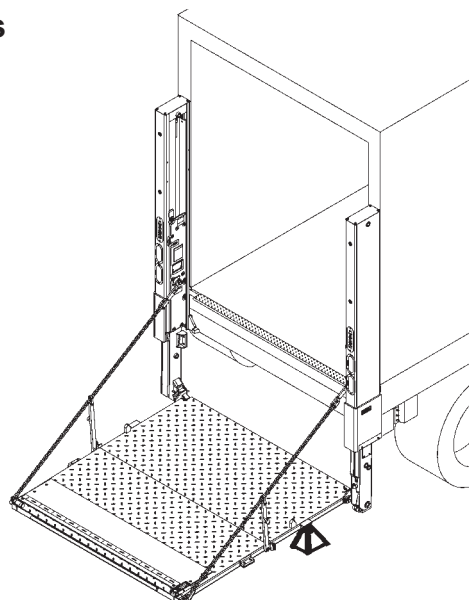

FIG. 29-3

13. If necessary, do the **BLEEDING HYDRAULIC FLUID** procedure in this manual.

REPLACING PARTS

RUNNER REPLACEMENT

NOTE: Refer to **Operation Manual** for instructions to operate Liftgate.

1. Use control box to lower the platform (**DOWN**) to approximately 12" above the ground. Support platform with 2 jack stands (**FIG. 30-1**). Make sure ramp edge is 4" higher than inboard edge of platform.

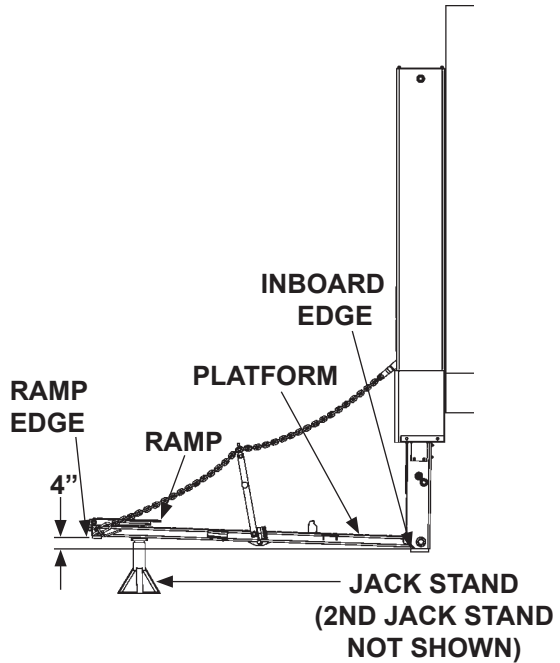

FIG. 30-1

2. Unbolt pin collar from RH runner to remove chain arm (**FIG 30-2**). Then, unbolt and remove cover from runner. Repeat for LH chain arm and LH runner.

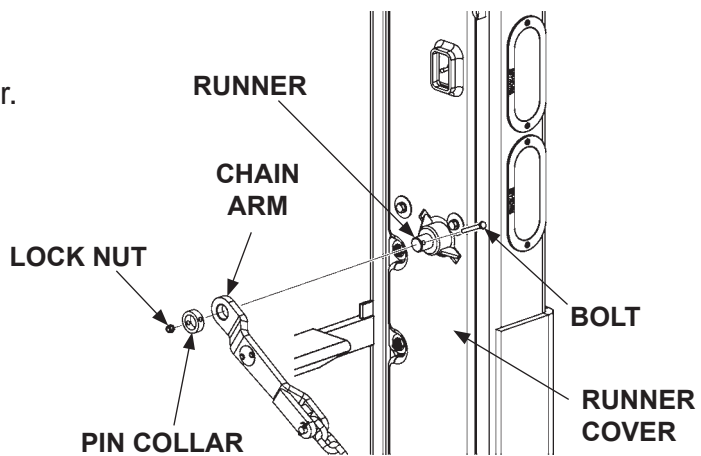

FIG. 30-2

MAXON[®]

11921 Slauson Ave. Santa Fe Springs, CA. 90670 (800) 227-4116 FAX (888) 771-7713

3. Raise the platform (**UP**) slightly and place 2 more jack stands near the inboard edge (**FIG. 31-1**).

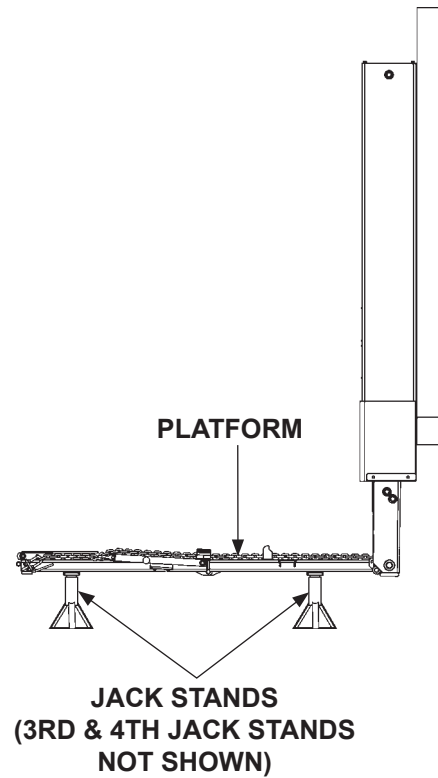

FIG. 31-1

4. Unbolt platform and connector bar from pin at the RH runner (**FIG. 31-2**). Then, remove pin. Repeat for LH runner.

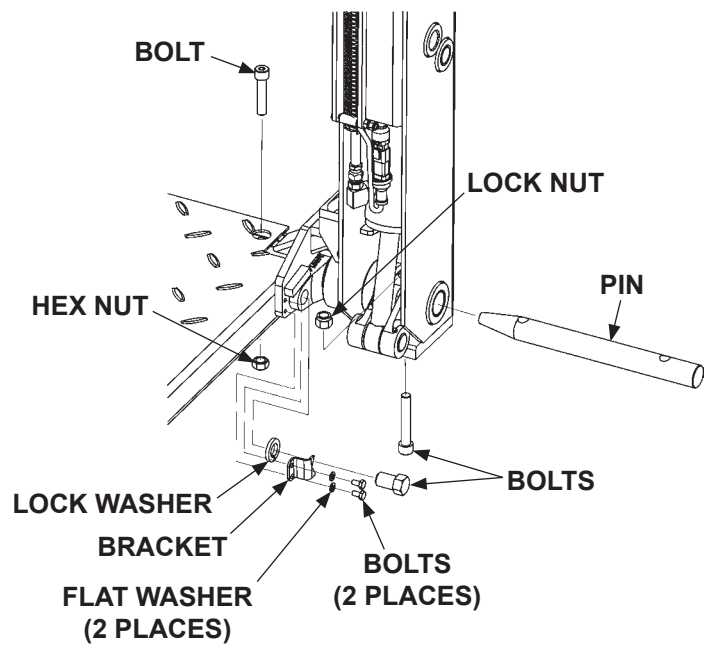

FIG. 31-2

REPLACING PARTS RUNNER REPLACEMENT - Continued

5. Use a forklift or equivalent lifting device to move the platform approximately 6" towards the front of the vehicle to clear the platform away from the attaching points on the runners (**FIG. 32-1**). When platform is clear of the runners, raise the runners (**UP**) a few inches. Then, move platform away from liftgate and the back of the vehicle.

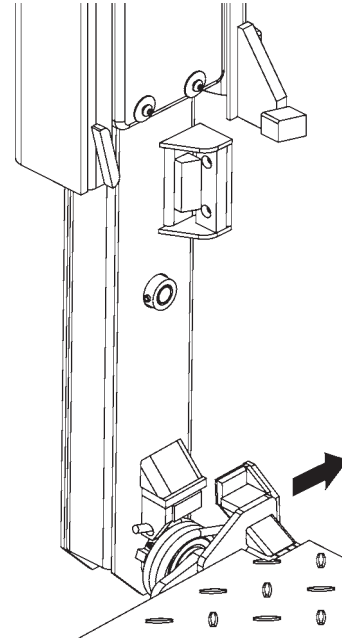

FIG. 32-1

6. Use the control box to lower runners (**DOWN**) to the ground.

NOTE: If replacing LH runner, skip steps 7, 8, and 9.

7. Do the opening/closing cylinder removal steps in the **OPENING/CLOSING CYLINDER REPLACEMENT** procedure in this manual.
8. Disconnect runner switch cable from flexible cable near bottom of runner as shown in **FIG. 32-2**. Then, unfasten runner switch cable clamp from runner by removing lock nut (**FIG. 32-2**). Remove clamp from cable connector.
9. Pull spring guard, flexible cable, and twin hydraulic hoses away from the channel at bottom of runner (**FIG. 32-2**).

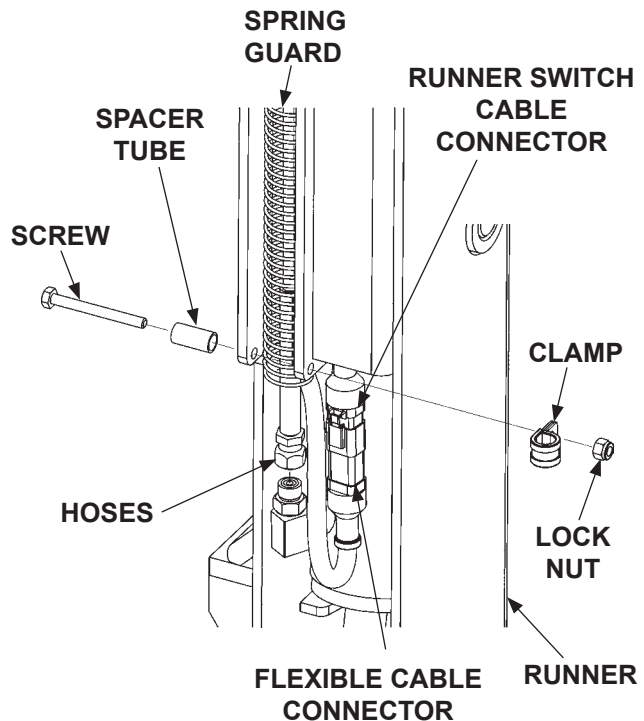
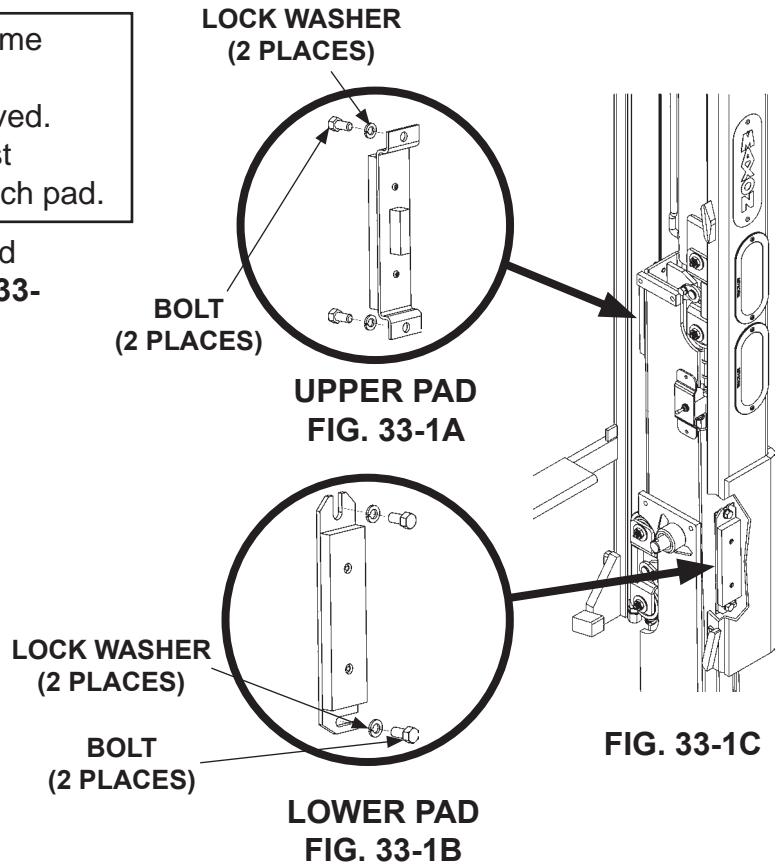

FIG. 32-2

NOTE: Keep shims in the same position on each pad when pads are removed. The same shims must be reinstalled with each pad.

10. Unbolt the upper and lower pad assemblies and shims (**FIGS. 33-1A & 33-1B**) from runner (**FIG. 33-1C**).



11. Unbolt the anchor pin from the tandem roller at the top of runner (**FIG. 33-2**). Next, move top of runner toward vehicle body for enough clearance to remove tandem rollers. Then, remove the tandem rollers (**FIG. 33-2**).

NOTE: If more clearance is necessary to remove the tandem rollers at the bottom of runner, unbolt roller bracket from the rollers.

12. For the tandem rollers at the bottom of runner, unbolt the anchor pin (**FIG. 33-2**). Next, move bottom of runner away from vehicle body for enough clearance to remove tandem rollers. Then, remove the tandem rollers (**FIG. 33-2**).

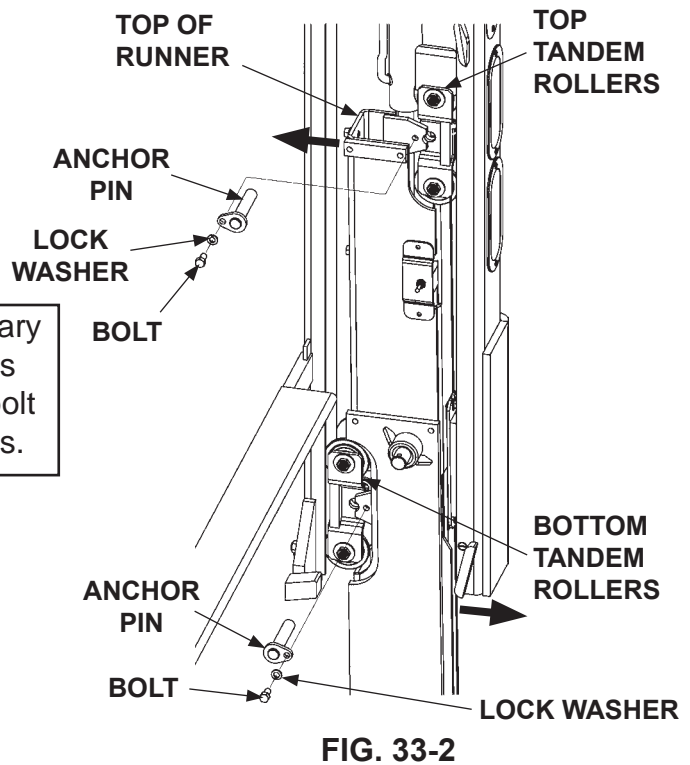

REPLACING PARTS RUNNER REPLACEMENT - Continued

13. Disconnect lifting hydraulic line from fitting on flow control valve near top of lifting cylinder. Hold cylinder firmly and remove roll pin and upper pin (FIG. 34-1).

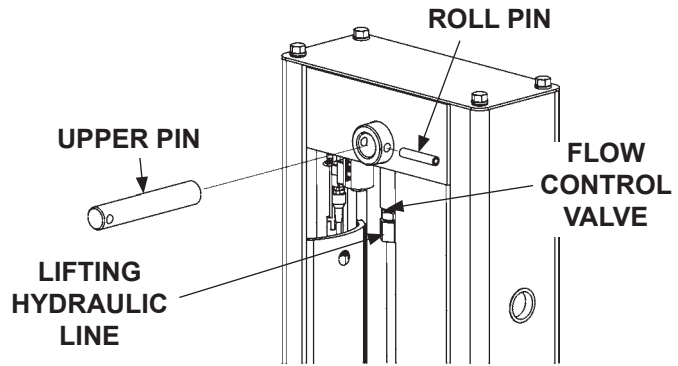

FIG. 34-1

14. Lower cylinder slowly a few inches to gain access to hydraulic line connector. Plug the lifting line to prevent cylinder from compressing.

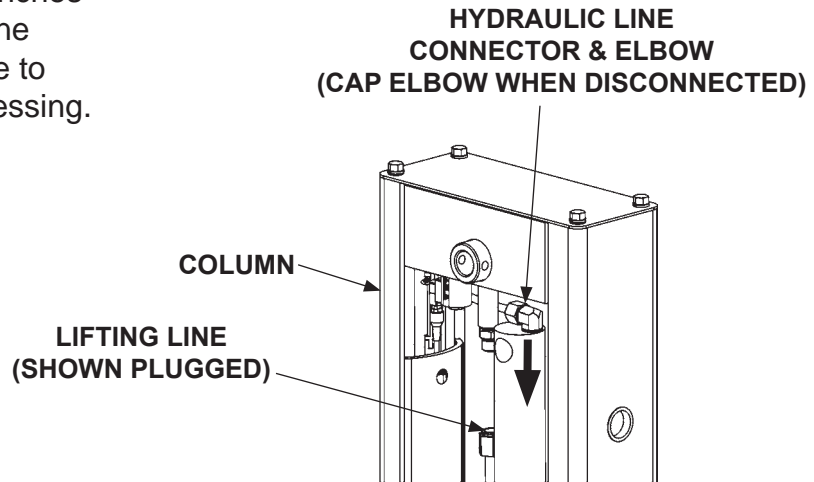

FIG. 34-2

15. Disconnect hydraulic line from elbow on top of cylinder (FIG. 34-2). Then cap the elbow.

MAXON[®]

11921 Slauson Ave. Santa Fe Springs, CA. 90670 (800) 227-4116 FAX (888) 771-7713

16. Twist and walk runner out of column (FIG. 35-1). Then lay runner and cylinder on the ground.

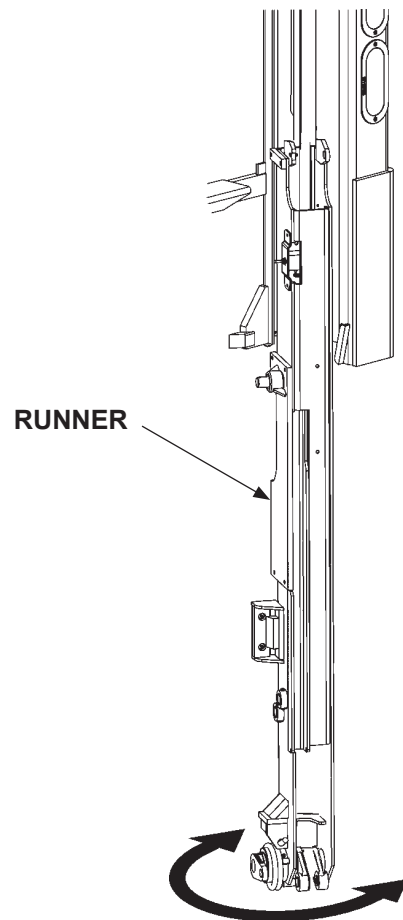

FIG. 35-1

CAUTION

Prevent damage to cylinder rod.
Be careful removing cylinder from runner.

17. Remove roll pin and lower pin from runner (FIG. 35-2). Pull cylinder from runner.

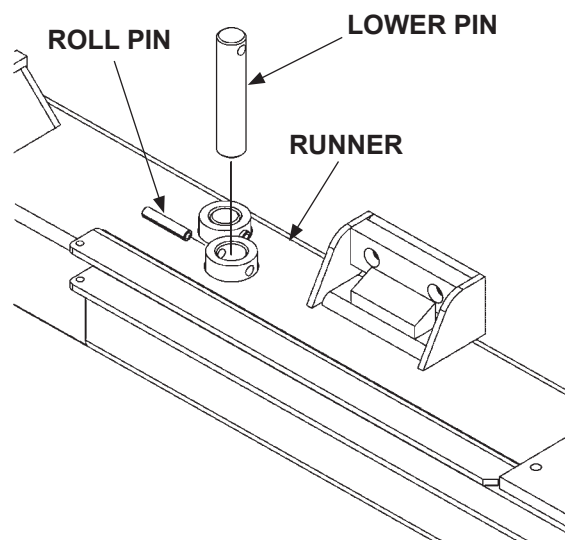
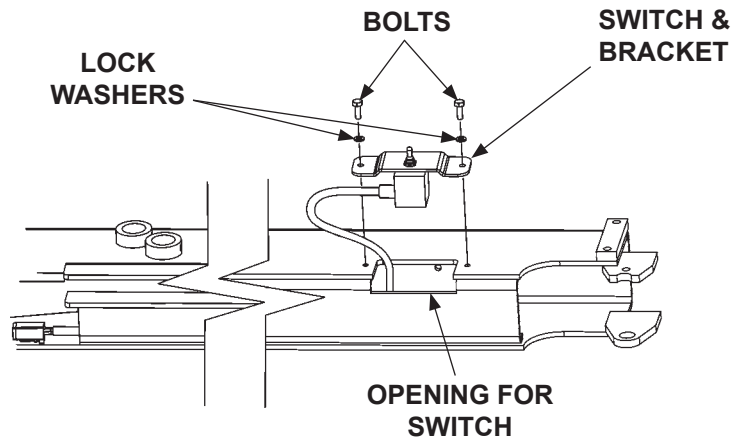

FIG. 35-2

REPLACING PARTS RUNNER REPLACEMENT - Continued

18. If RH runner is being replaced, unbolt switch mounting bracket as shown in **FIG. 36-1**. Pull switch, bracket, and cable from the runner.



REMOVING SWITCH FROM RH RUNNER
FIG. 36-1

CAUTION

Avoid making sharp bends in wiring.

19. If RH runner is being replaced, reinstall switch, bracket, and cable in runner as follows. Make a wire fish by feeding 8 feet of small gauge wire through switch opening in runner (**FIG. 36-1**). Pull wire through channel at lower end of runner. Leave enough wire at the switch opening to attach to switch cable, and enough wire to pull at the lower end of runner. Tie upper end of wire fish to switch cable connector. Pull connector and cable through runner until connector exits lower end of runner. Then, bolt switch mounting bracket to runner (**FIG. 36-1**).

MAXON[®]

11921 Slauson Ave. Santa Fe Springs, CA. 90670 (800) 227-4116 FAX (888) 771-7713

CAUTION

Prevent damage to cylinder rod.
Be careful inserting cylinder in
runner.

- Slide rod end of lifting cylinder in top of runner (**FIG. 37-1**). Then reinstall lower pin and roll pin (**FIG. 37-2**).

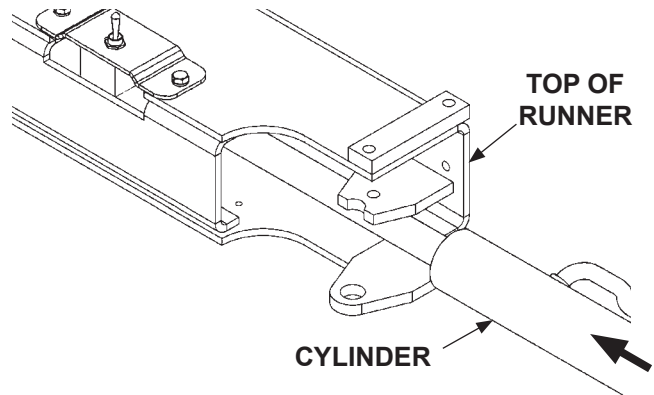

INSERTING CYLINDER IN RUNNER
FIG. 37-1

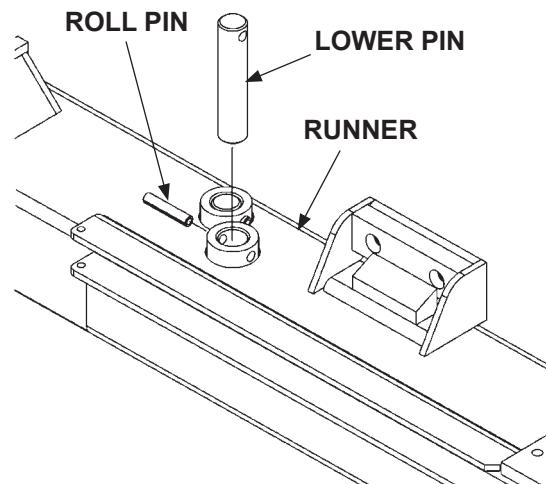

FIG. 37-2

REPLACING PARTS RUNNER REPLACEMENT - Continued

21. Stand the runner and cylinder upright. Twist and walk runner into column (FIG. 38-1).

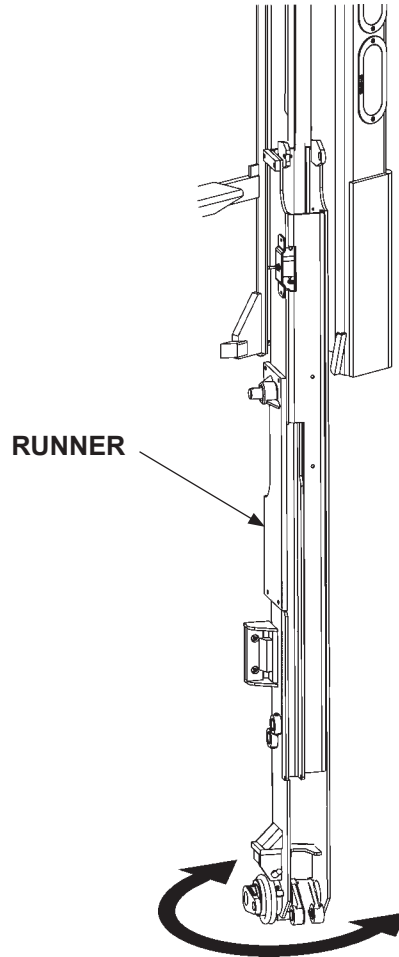

FIG. 38-1

22. Remove cap from elbow on top of cylinder (FIG. 38-2). Then re-connect power down line to elbow.

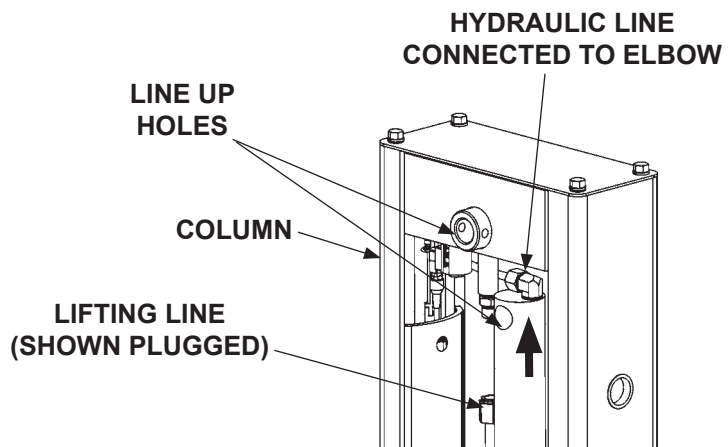

FIG. 38-2

23. Remove plug from lifting line (FIG. 38-2). Then, raise the cylinder to line up the holes on cylinder and column.

MAXON[®]

11921 Slauson Ave. Santa Fe Springs, CA. 90670 (800) 227-4116 FAX (888) 771-7713

24. Holding the cylinder firmly, reinstall upper pin and roll pin (FIG. 39-1). Then, reconnect lifting line to flow control valve (FIG. 39-1).

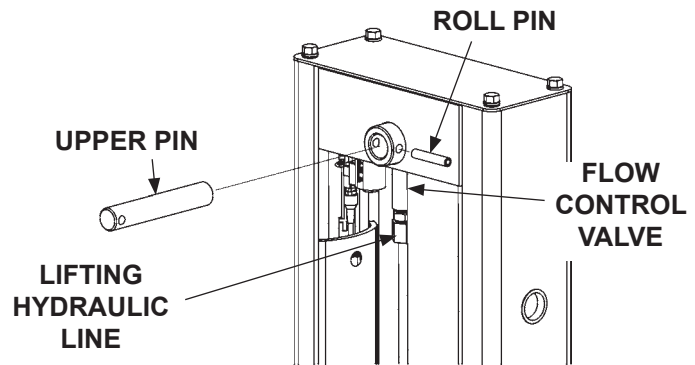

FIG. 39-1

NOTE: If roller bracket was unbolted from tandem rollers, reinstall bracket when tandem rollers are reinstalled at bottom of runner.

25. Reinstall tandem rollers at the bottom of runner as follows. Move bottom of runner away from vehicle body for enough clearance to insert tandem rollers (FIG. 39-2). Insert the tandem rollers in correct position. Then bolt anchor pin to runner (FIG. 39-2).

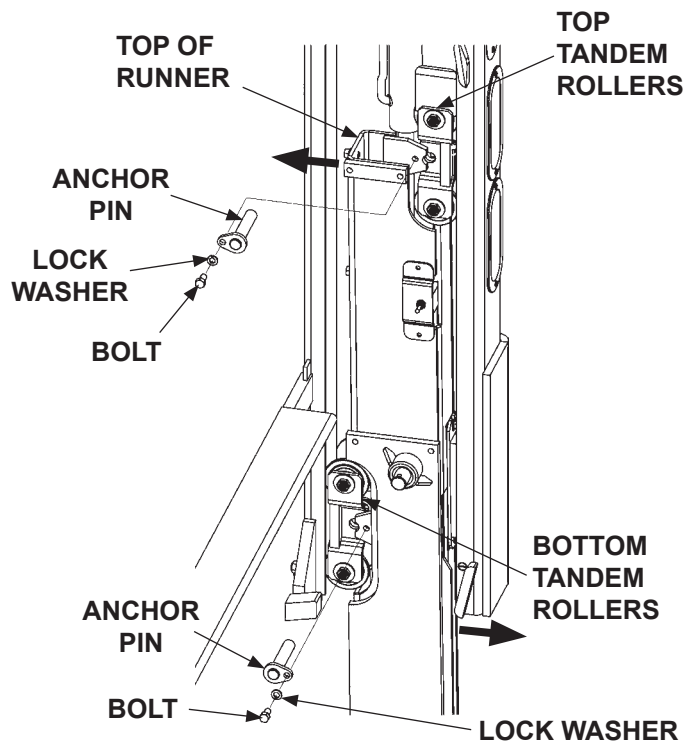

FIG. 39-2

26. To reinstall tandem rollers at top of runner, do the following. Move top of runner toward vehicle body for enough clearance to insert tandem rollers (FIG. 39-2). Insert the tandem rollers in correct position. Then bolt anchor pin to runner (FIG. 39-2).

REPLACING PARTS RUNNER REPLACEMENT - Continued

NOTE: To reinstall the pads, use the same shim setup that was removed with the pads. Clearance between pad and guide in the column should be a maximum of .03".

27. Bolt the upper and lower pads (FIGS. 40-1A & 40-1B) on the runner (FIG. 40-1C).

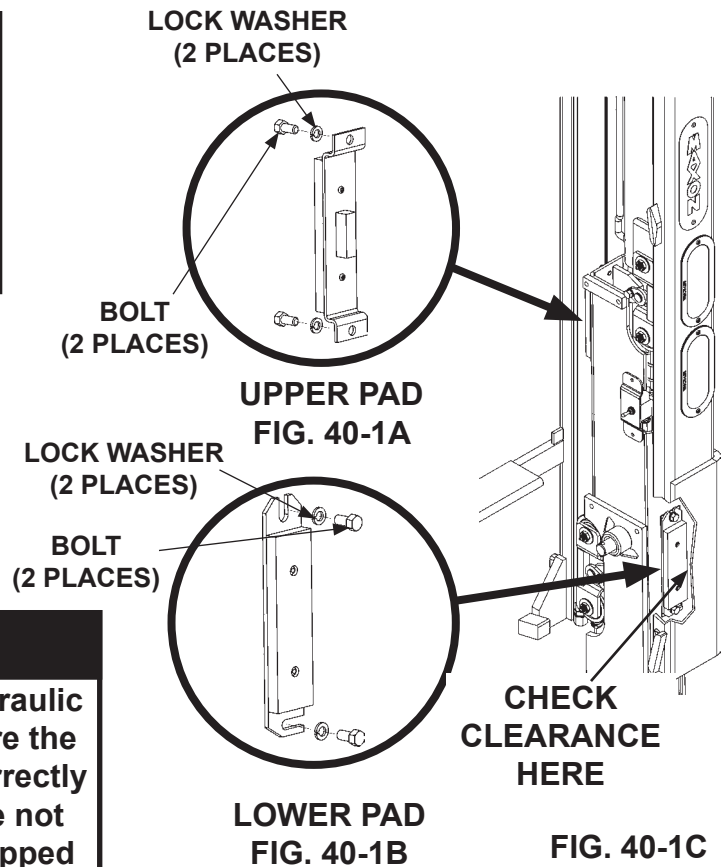

CAUTION

To prevent damage to twin hydraulic hoses and flexible cable, ensure the hoses and cable are routed correctly inside the spring guard and are not twisted. Cable must not be wrapped around the hydraulic hoses.

NOTE: If replacing LH runner, skip steps 28, 29, 30, & 31.

28. Place spring guard with flexible cable and twin hydraulic hoses, in channel at bottom of runner (FIG. 40-2).
29. Position spacer at the 3rd and 4th coils of the spring guard (FIG. 40-2). Then, screw the spacer to runner.

CAUTION

Avoid making sharp bends in wiring.

NOTE: MAXON recommends using dielectric grease on all electrical connections.

30. Reconnect runner switch cable to flexible cable at bottom of runner (FIG. 40-2). Use clamp and lock nut to fasten molded portion of connector to runner (FIG. 40-2).

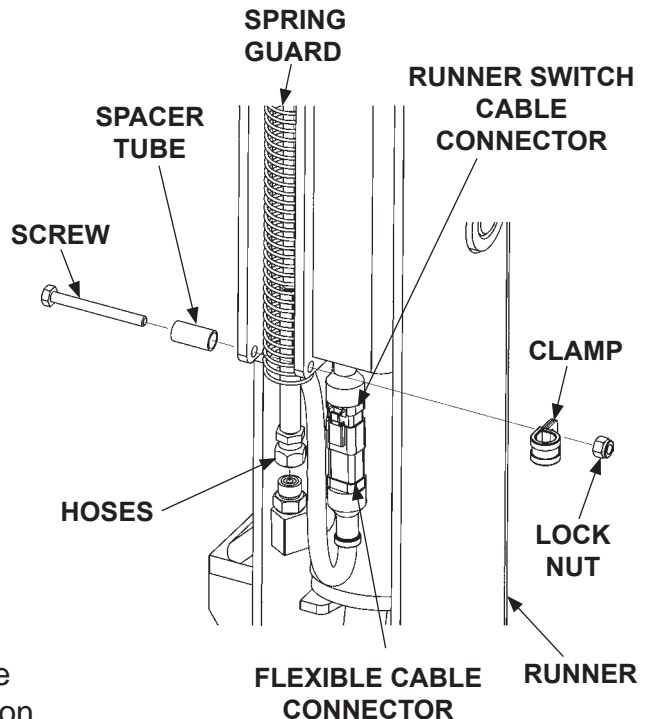

FIG. 40-2

31. To reinstall opening/closing cylinder, do the opening/closing cylinder replacement steps in the **OPENING/CLOSING CYLINDER REPLACEMENT** procedure in this manual.

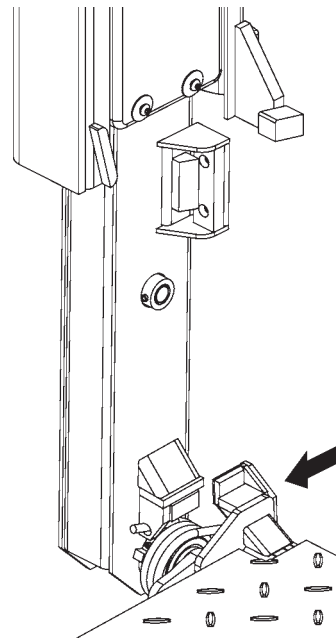

FIG. 41-1

32. Use a forklift or equivalent lifting device to lift platform and line it up with attaching points on the LH runner (**FIG. 41-1**) and RH runner.

33. Insert pin through runner, couplings and connector bar at the RH runner. Then, bolt platform and connector bar to pin (**FIG. 41-2**). Repeat for LH runner.

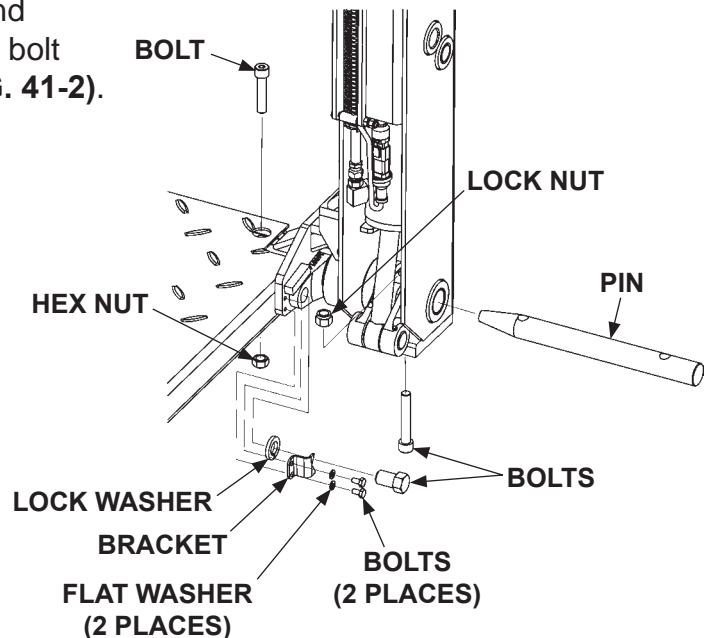

FIG. 41-2

REPLACING PARTS

RUNNER REPLACEMENT - Continued

34. Use control box to raise the platform **(UP)** slightly and remove 2 jack stands near the inboard edge (**FIG. 42-1**).

35. Use control box to lower **(DOWN)** platform on jack stands (**FIG. 42-1**) so inboard edge is 4" below ramp edge.

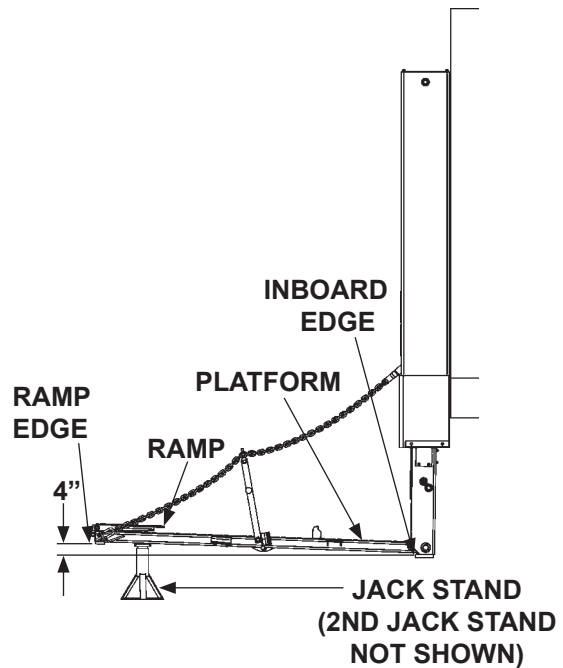

FIG. 42-1

NOTE: The runner cover, with the "ALIGN ARROWS" decal, is installed on the LH runner.

NOTE: If a new cover is being bolted on the LH runner, the serial plate must be transferred from old cover to new cover. Also, a new "ALIGN ARROWS" decal must be installed on the new cover.

36. Bolt the runner cover to RH runner (**FIG. 42-2**). Next, reattach chain arm to RH runner. Then, bolt on the pin collar to secure chain arm (**FIG. 42-2**). Repeat for LH runner.

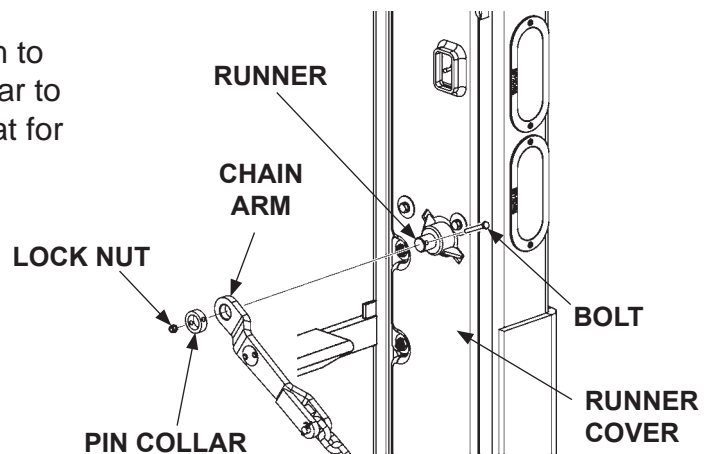

FIG. 42-2

37. If necessary, do the **BLEEDING HYDRAULIC FLUID** procedure in this manual.

MAXON[®]

11921 Slauson Ave. Santa Fe Springs, CA. 90670 (800) 227-4116 FAX (888) 771-7713

HYDRAULIC SYSTEM DIAGRAMS

PUMP & MOTOR SOLENOID OPERATION

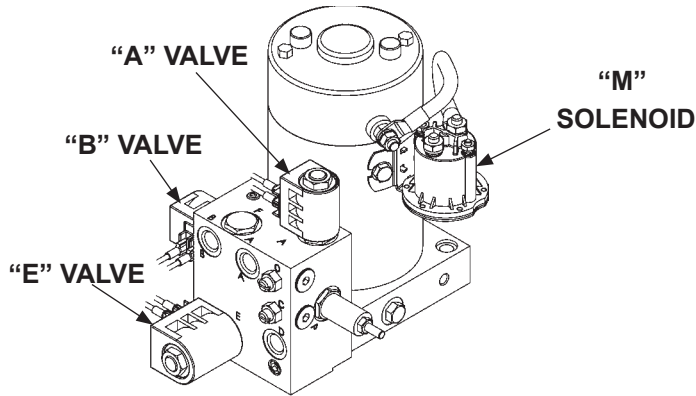

GRAVITY DOWN PUMP/MOTOR
FIG. 43-1

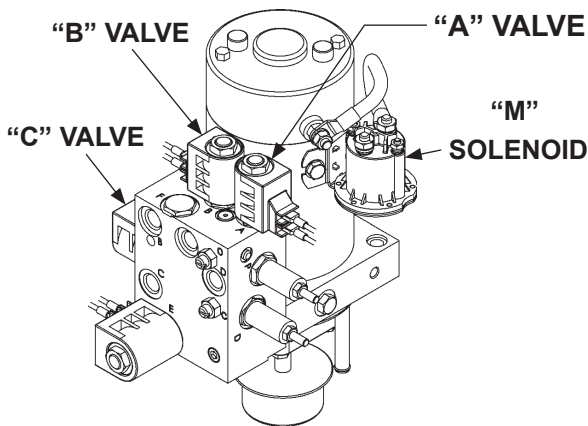

POWER DOWN PUMP/MOTOR
FIG. 43-2

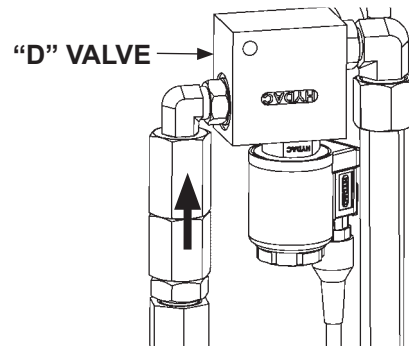

"D" VALVES (TOP OF EACH COLUMN)
FIG. 43-3

SOLENOID OPERATION		
FUNCTION	SOLENOID ENERGIZED	ACTION
UP	M	Motor runs; Oil flows from "B" Port, thru Flow Divider, thru "D" Valves to Lift Cylinders.
DOWN	GRAVITY - B & D (FIGS. 43-1 & 43-3)	"B & D" Valves open, allowing oil to return from lift cylinders to the reservoir.
	POWER - M,B,C, & D (FIGS. 43-2 & 43-3)	Motor runs; "B,C,& D" valves open, allowing oil to return from lift cylinders to reservoir.
FOLD PLATFORM	M & E	Motor runs; "E" valve shifts, oil flows from port "A" to the folding cylinder.
UNFOLD PLATFORM	A	"A" valve opens, allowing oil to return from the folding cylinder to reservoir.

TABLE 43-1

HYDRAULIC SCHEMATIC, SINGLE PUMP GRAVITY DOWN

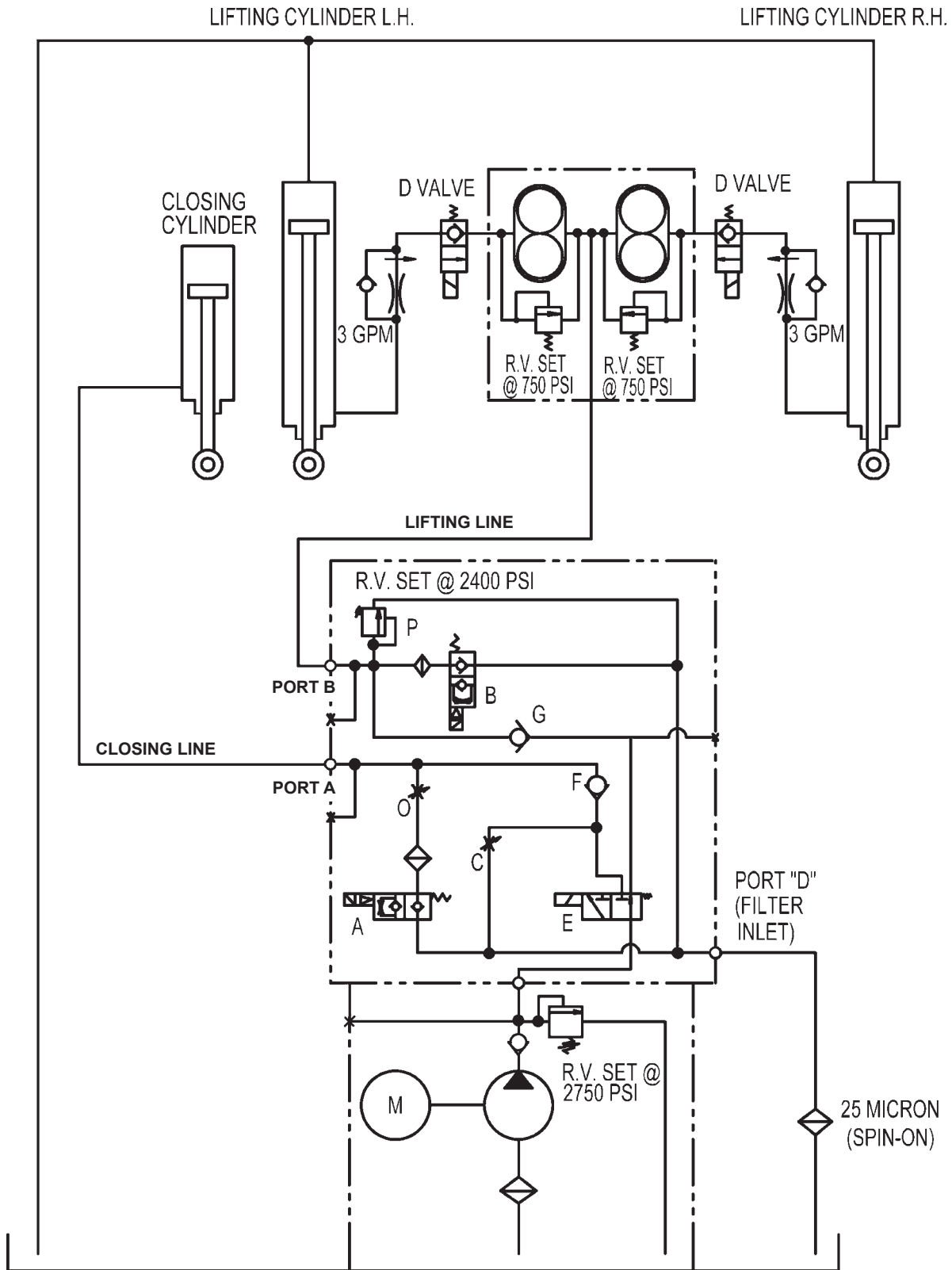

FIG. 44-1

HYDRAULIC SYSTEM DIAGRAMS

HYDRAULIC SCHEMATIC, DUAL PUMP GRAVITY DOWN

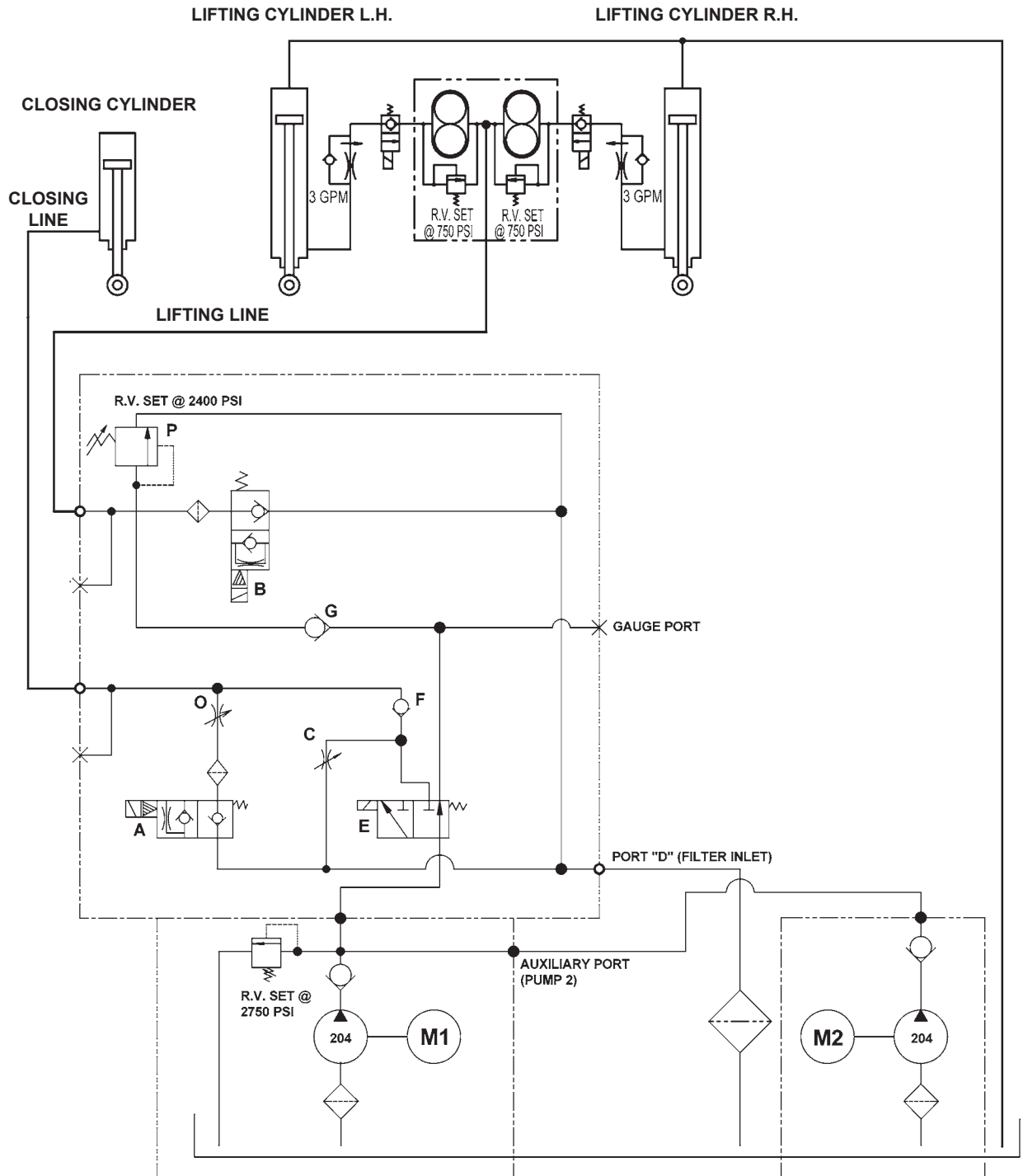
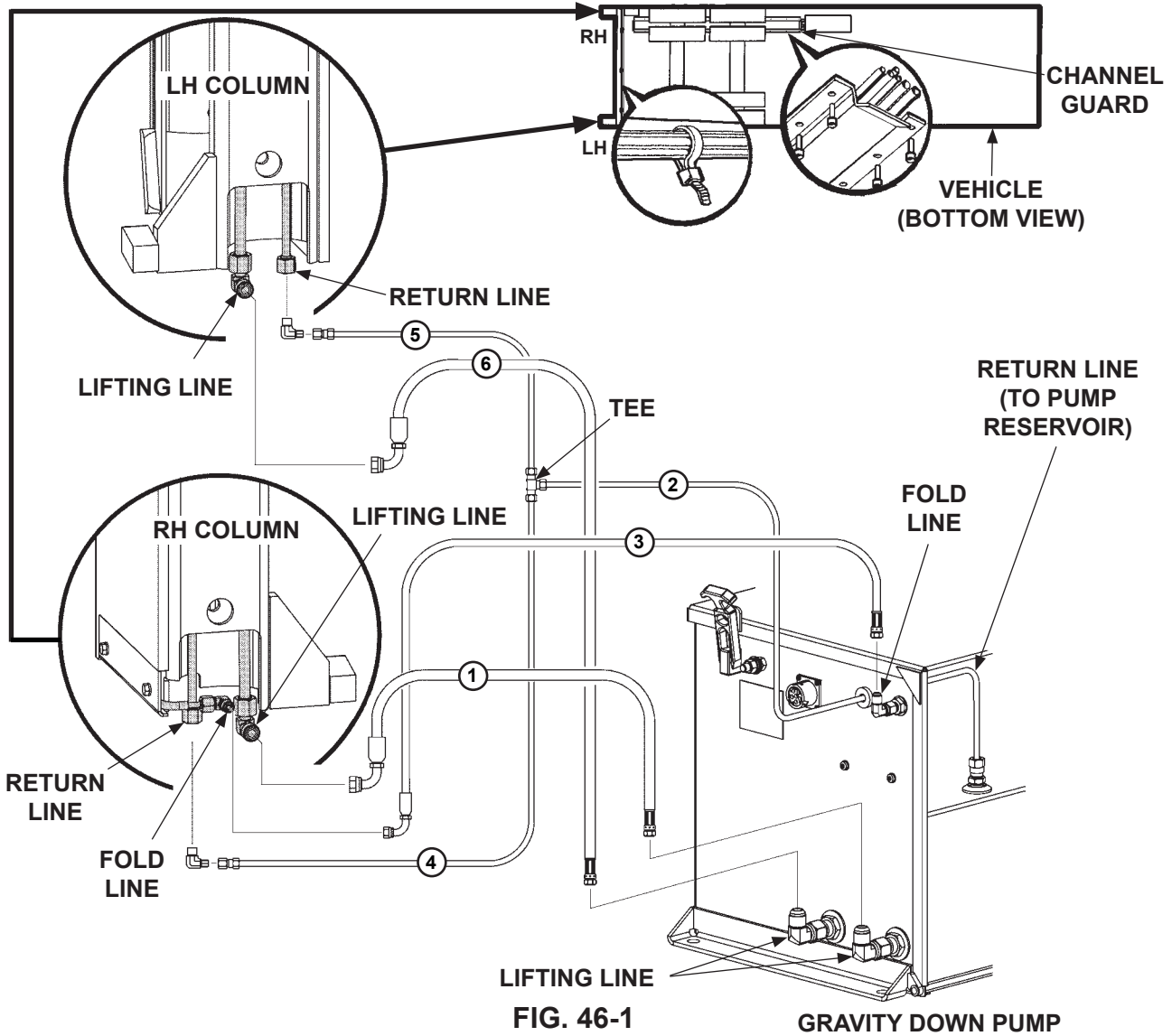

FIG. 45-1

GRAVITY DOWN HYDRAULIC LINES IDENTIFICATION

NOTE: See TABLE 46-1 for information on the numbered hoses in this illustration.

CAUTION
Before connecting hoses, ensure face seal o-rings are in place.



GRAVITY DOWN PUMP BOX INSTALLATION: REQUIRED HOSES & PLASTIC TUBING			
	3 FT.	10 FT.	20 FT.
1	HP 3/8" X 64" LG.	HP 3/8" X 196" LG.	HP 3/8" X 316" LG.
2	PLASTIC 3/8" OD X 84" LG.	PLASTIC 3/8" OD X 192" LG.	PLASTIC 3/8" OD X 324" LG.
3	HP 1/4" X 56" LG.	HP 1/4" X 188" LG.	HP 1/4" X 308" LG.
4	PLASTIC 3/8" OD X 24" LG.		
5	PLASTIC 3/8" OD X 108" LG.		
6	HP 3/8" X 142" LG.	HP 3/8" X 274" LG.	HP 3/8" X 394" LG.

TABLE 46-1

MAXON

11921 Slauson Ave. Santa Fe Springs, CA. 90670 (800) 227-4116 FAX (888) 771-7713

HYDRAULIC SYSTEM DIAGRAMS

HYDRAULIC SCHEMATIC, SINGLE PUMP POWER DOWN

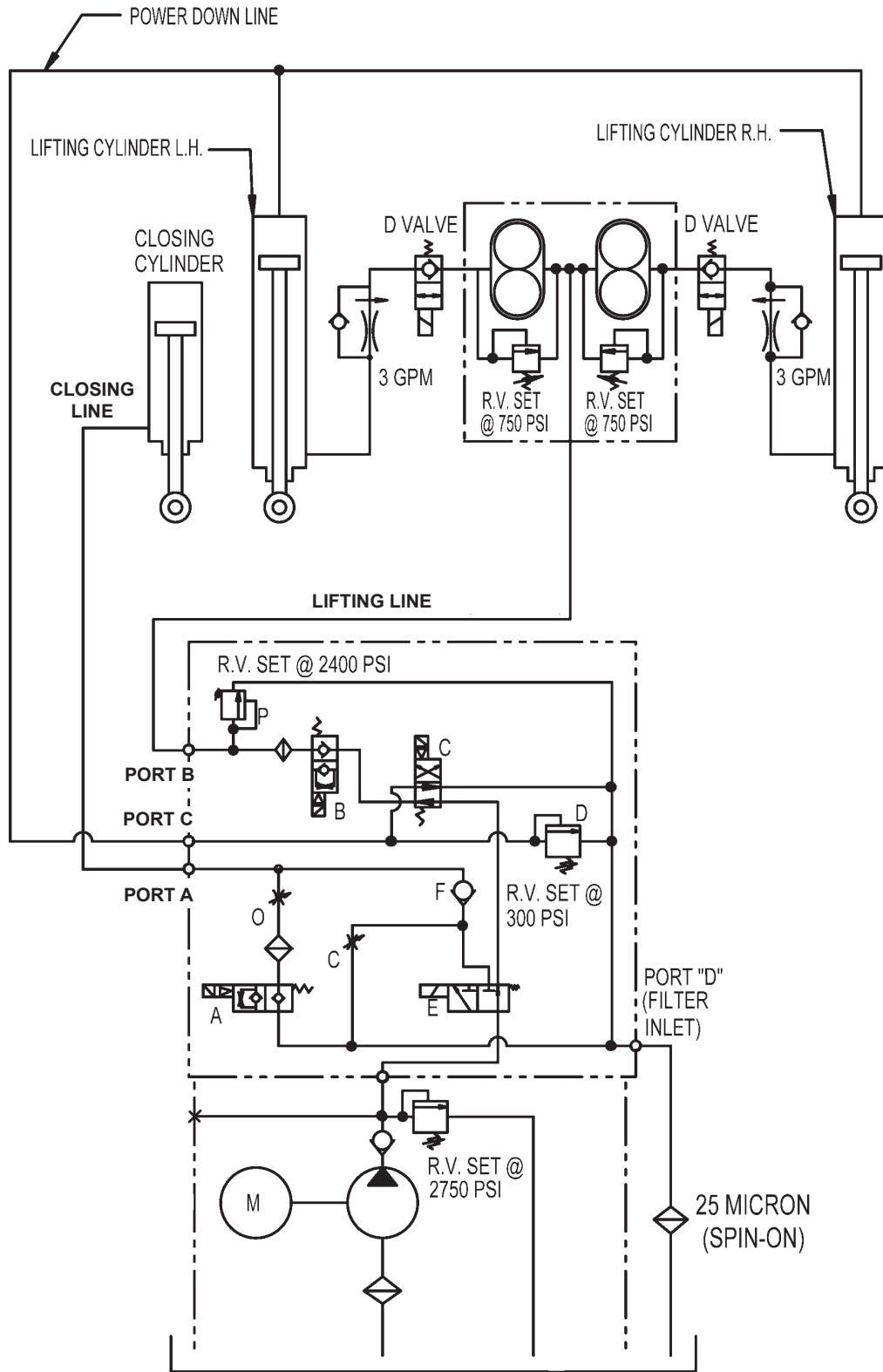

FIG. 47-1

HYDRAULIC SCHEMATIC, DUAL PUMP POWER DOWN

MAXON[®]
 11921 Slauson Ave. Santa Fe Springs, CA. 90670 (800) 227-4116 FAX (888) 771-7713

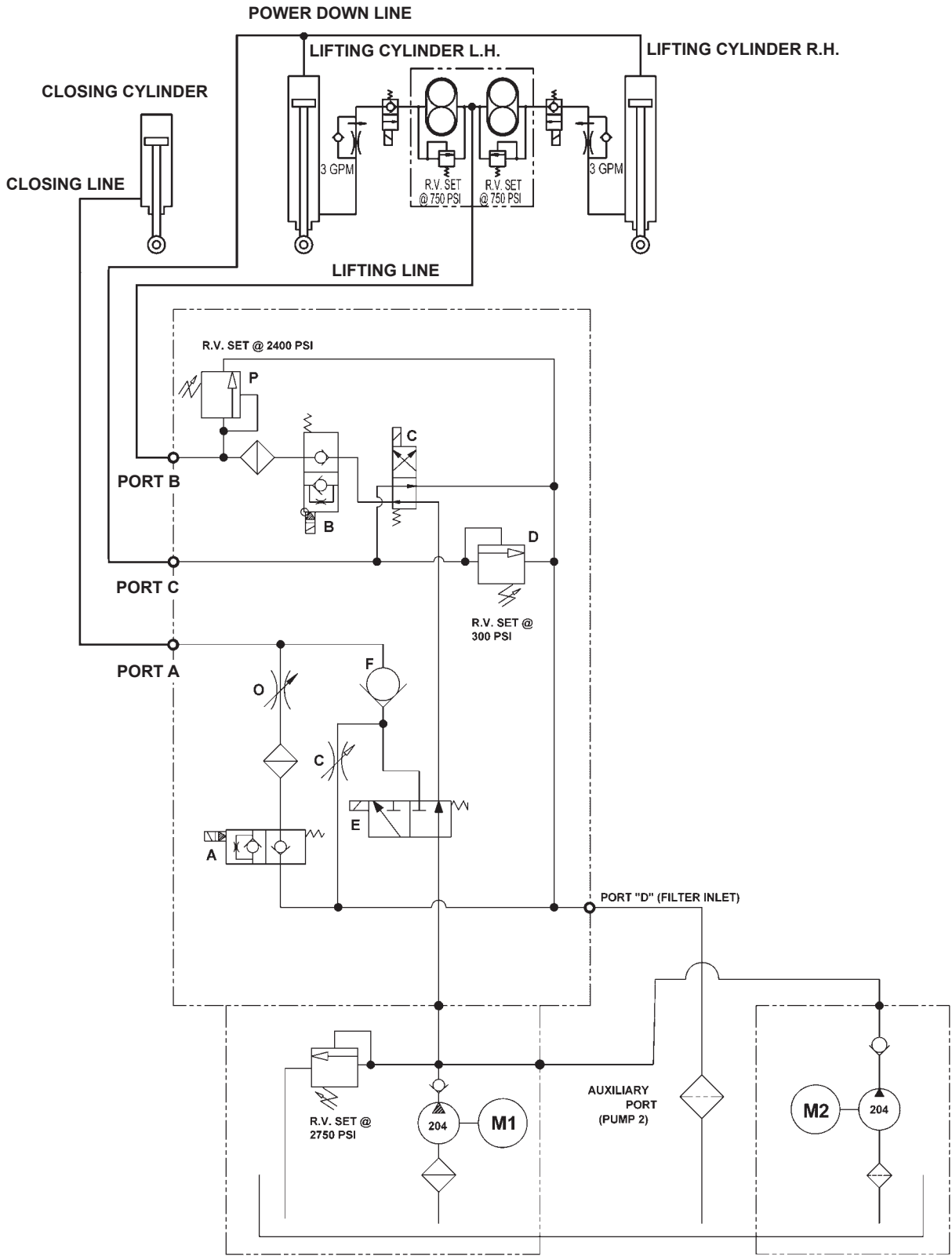

FIG. 48-1

HYDRAULIC SYSTEM DIAGRAMS

POWER DOWN HYDRAULIC LINES IDENTIFICATION

NOTE: See TABLE 49-1 for information on the numbered hoses in this illustration.

CAUTION
Before connecting hoses, ensure face seal o-rings are in place.

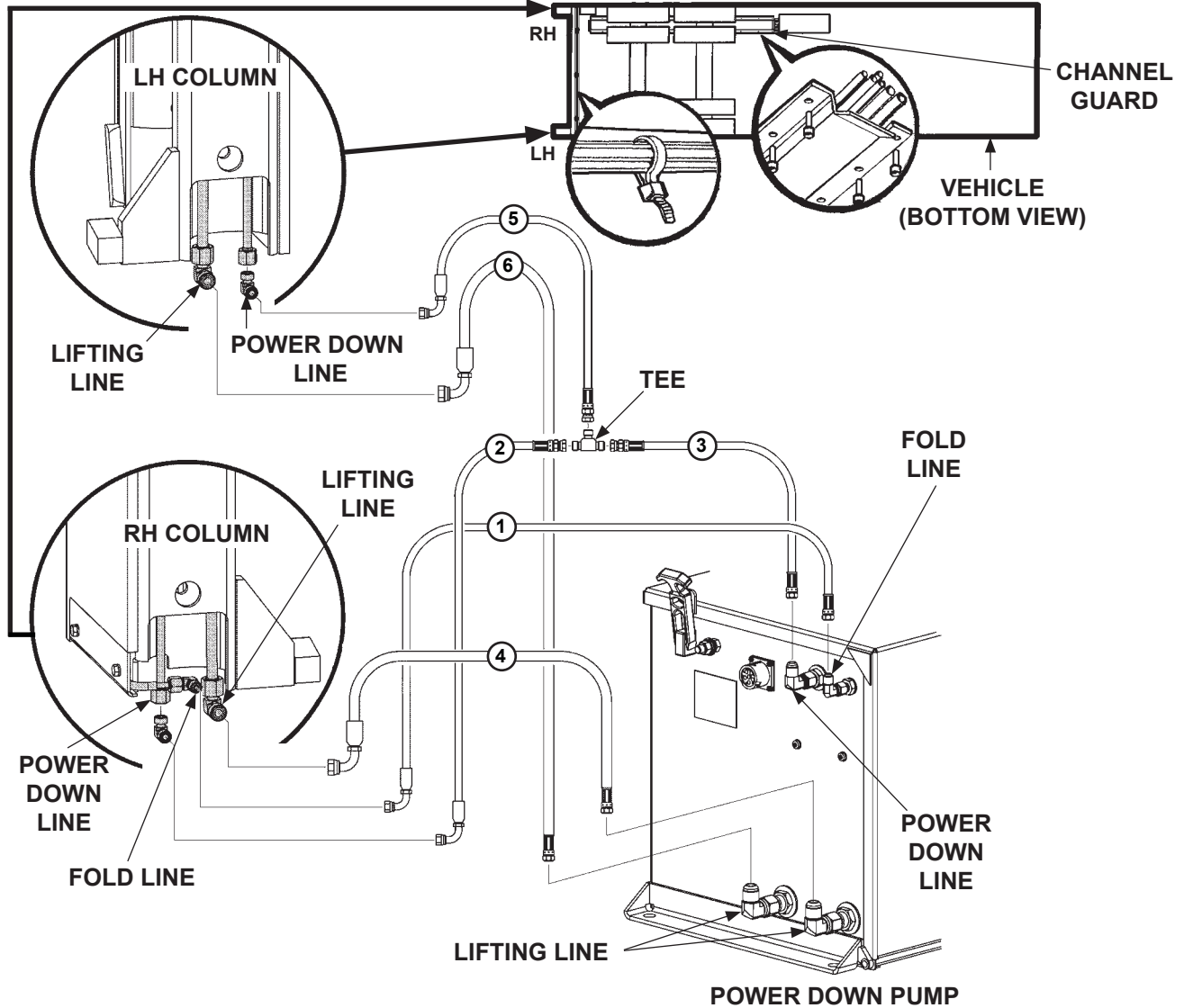

FIG. 49-1

POWER DOWN PUMP BOX INSTALLATION: REQUIRED HOSES			
	3 FT.	10 FT.	20 FT.
1	HP 1/4" X 56" LG.	HP 1/4" X 188" LG.	HP 1/4" X 308" LG.
2		HP 1/4" X 22" LG.	
3	HP 1/4" X 34" LG.	HP 1/4" X 166" LG.	HP 1/4" X 286" LG.
4	HP 3/8" X 64" LG.	HP 3/8" X 196" LG.	HP 3/8" X 316" LG.
5		HP 1/4" X 98" LG.	
6	HP 3/8" X 142" LG.	HP 3/8" X 274" LG.	HP 3/8" X 394" LG.

TABLE 49-1

ELECTRICAL SYSTEM DIAGRAMS

INTERCONNECTING ELECTRICAL SCHEMATIC

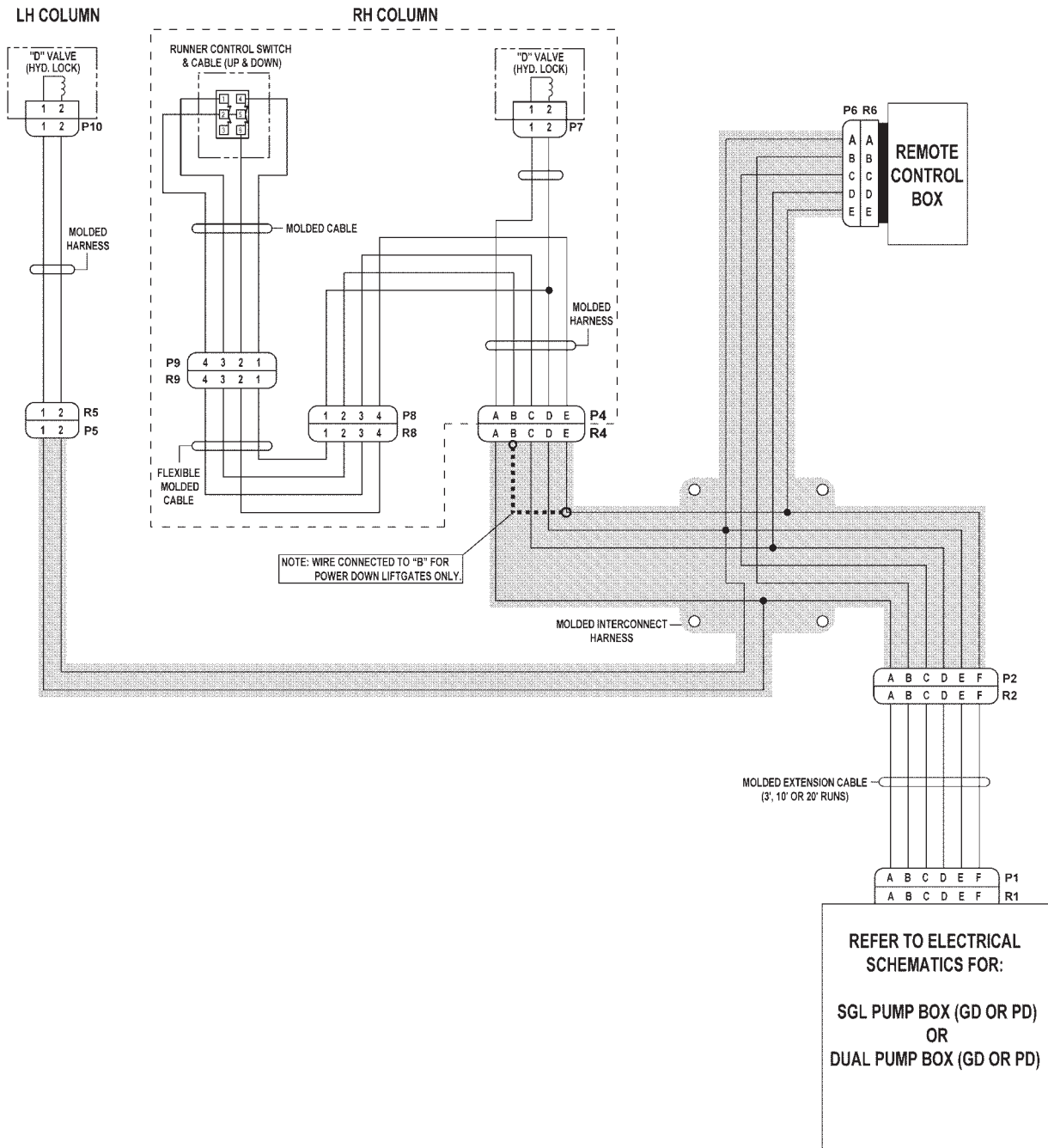

FIG. 50-1

MAXON®

11921 Slauson Ave. Santa Fe Springs, CA. 90670 (800) 227-4116 FAX (888) 771-7713

ELECTRICAL SYSTEM DIAGRAMS

SINGLE PUMP BOX, GRAVITY DOWN

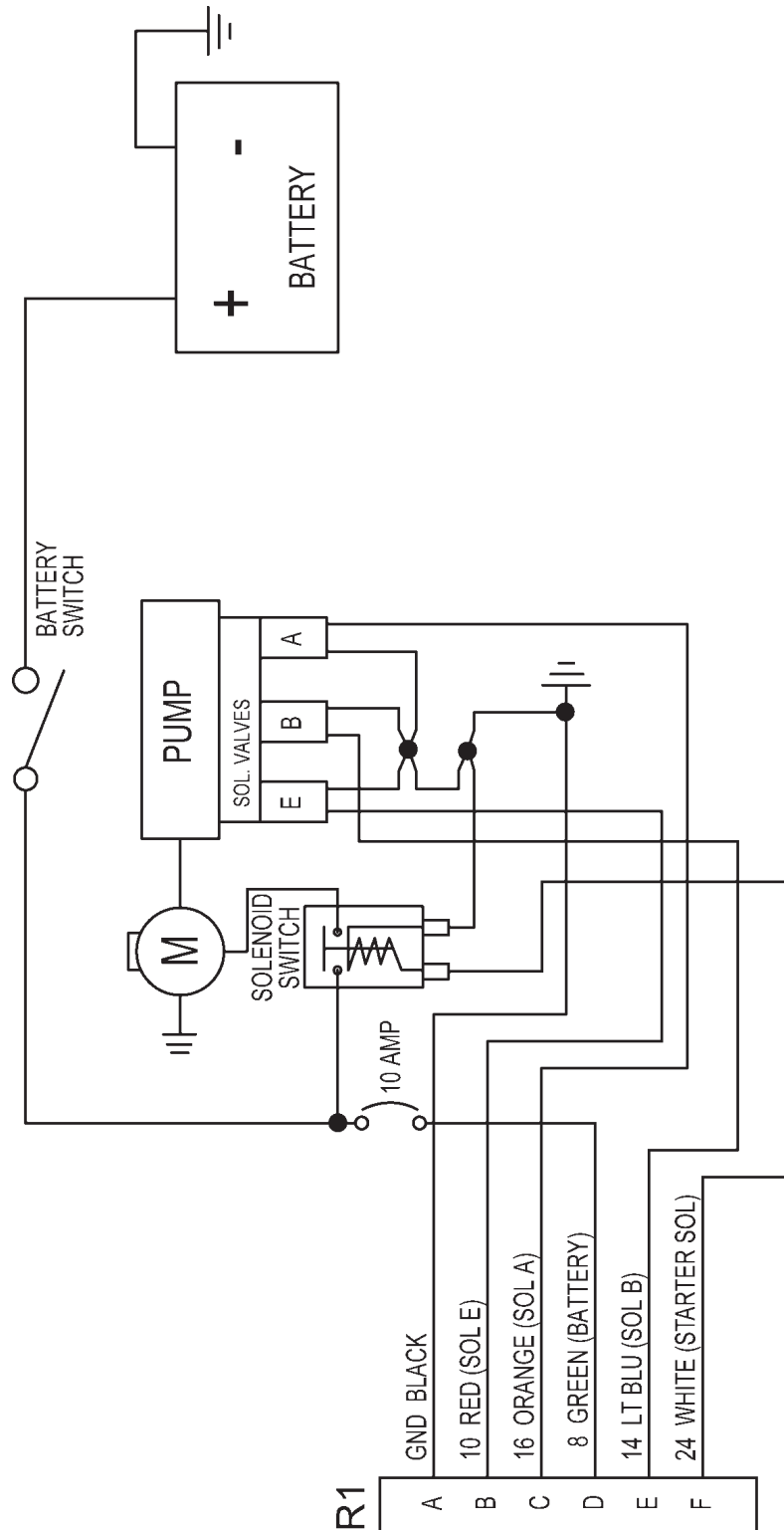

(From receptacle on pump box wall)

FIG. 51-1

DUAL PUMP BOX, GRAVITY DOWN

MAXON[®]

11921 Slauson Ave. Santa Fe Springs, CA. 90670 (800) 227-4116 FAX (888) 771-7713

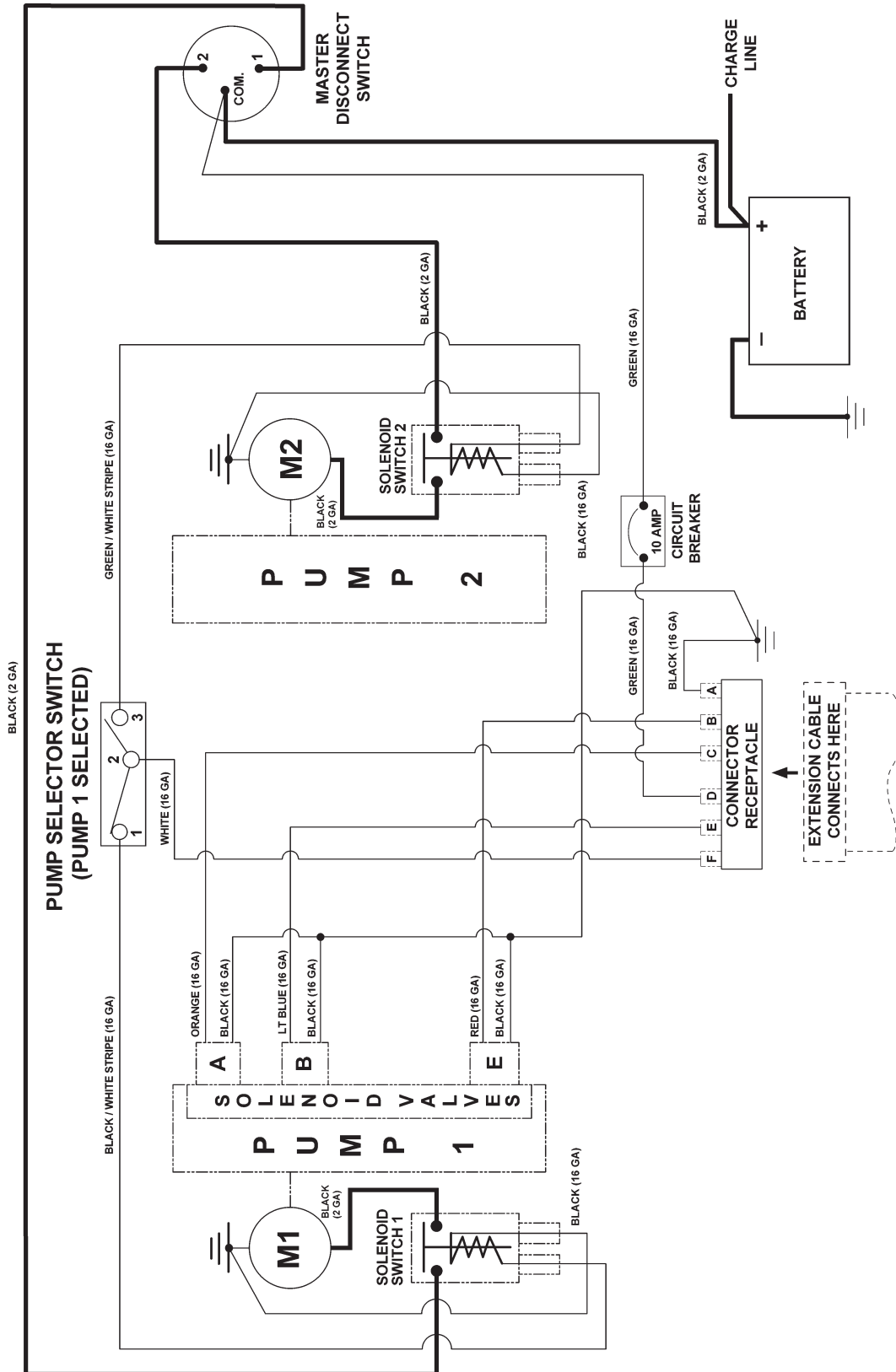
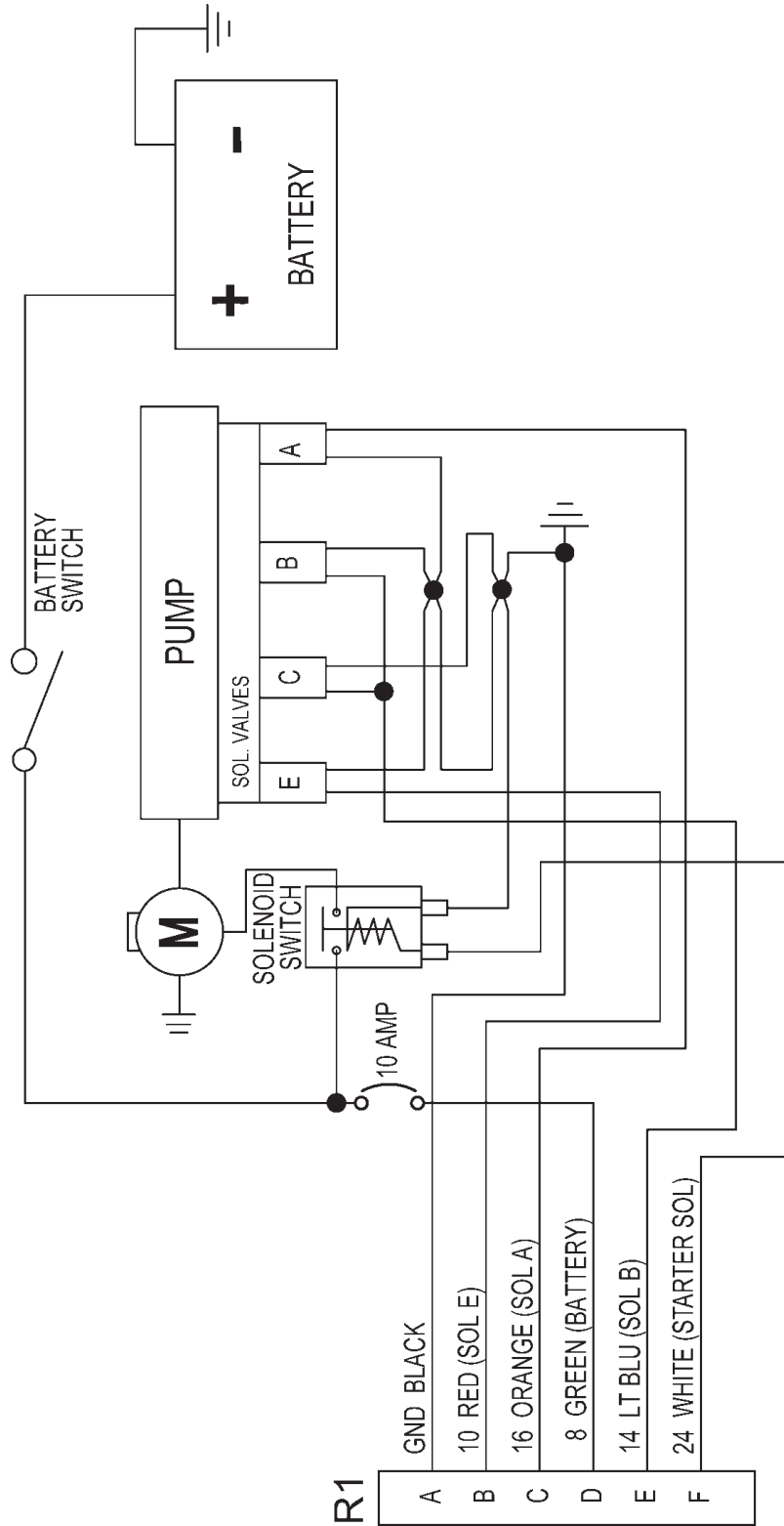

FIG. 52-1

ELECTRICAL SYSTEM DIAGRAMS

SINGLE PUMP BOX, POWER DOWN



(From receptacle on pump box wall)

FIG. 53-1

DUAL PUMP BOX, POWER DOWN

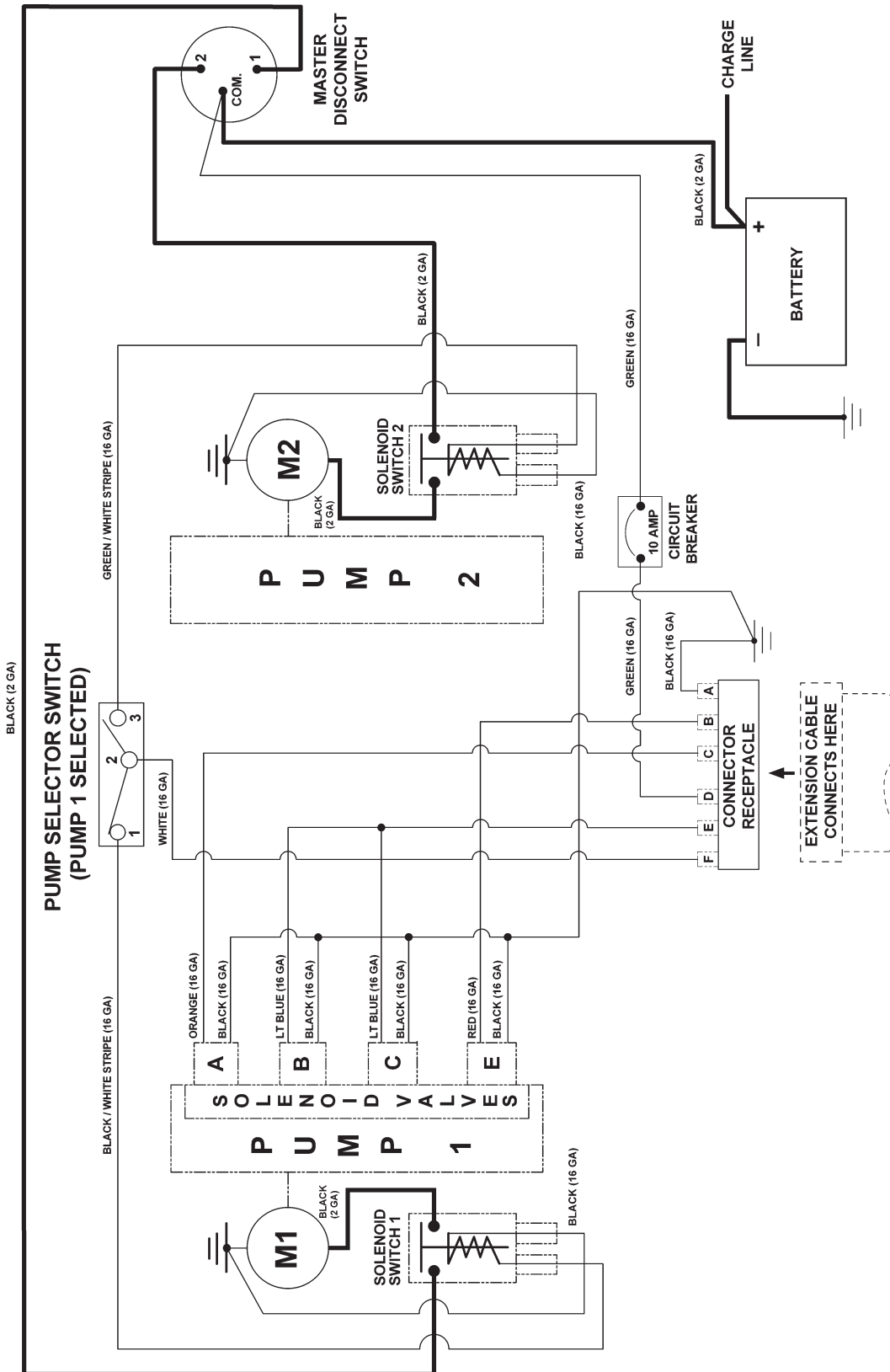
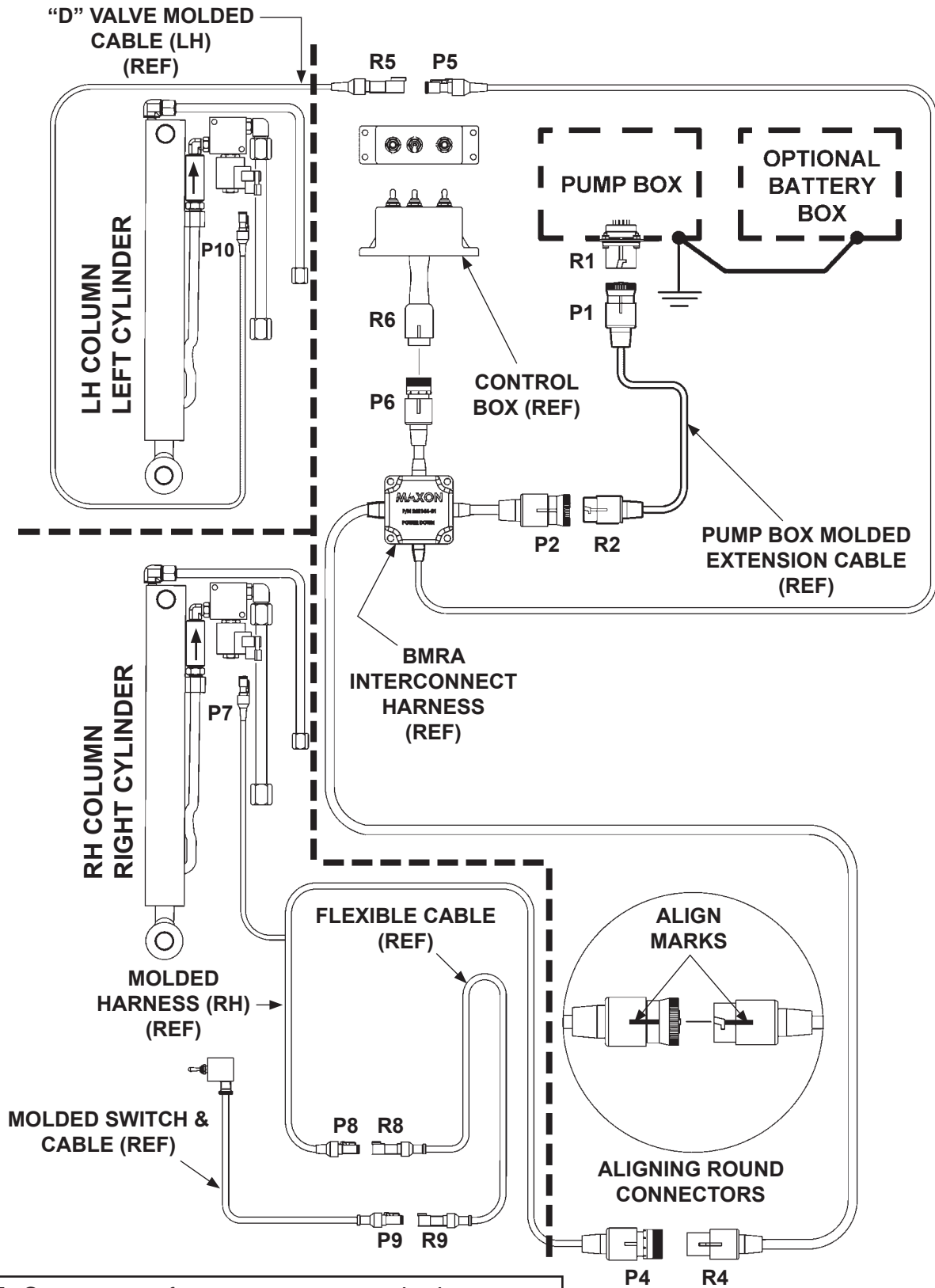

FIG. 54-1

ELECTRICAL SYSTEM DIAGRAMS

WIRING HARNESS CONNECTOR IDENTIFICATION



NOTE: Connector references are not marked on parts.

FIG. 55-1

MAXON[®]

11921 Slauson Ave. Santa Fe Springs, CA. 90670 (800) 227-4116 FAX (888) 771-7713

THIS PAGE INTENTIONALLY LEFT BLANK.

TROUBLESHOOTING

PLATFORM WILL NOT RAISE, MOTOR WILL NOT RUN

NOTE: For dual pump system, check secondary pump and motor first.

1. Check for 12.6 volts dc input to motor solenoid by using voltmeter between terminal A (**FIG. 57-1**) and ground. If there is no power to the motor solenoid, make sure pump box master disconnect switch is **ON** and circuit breaker is set.

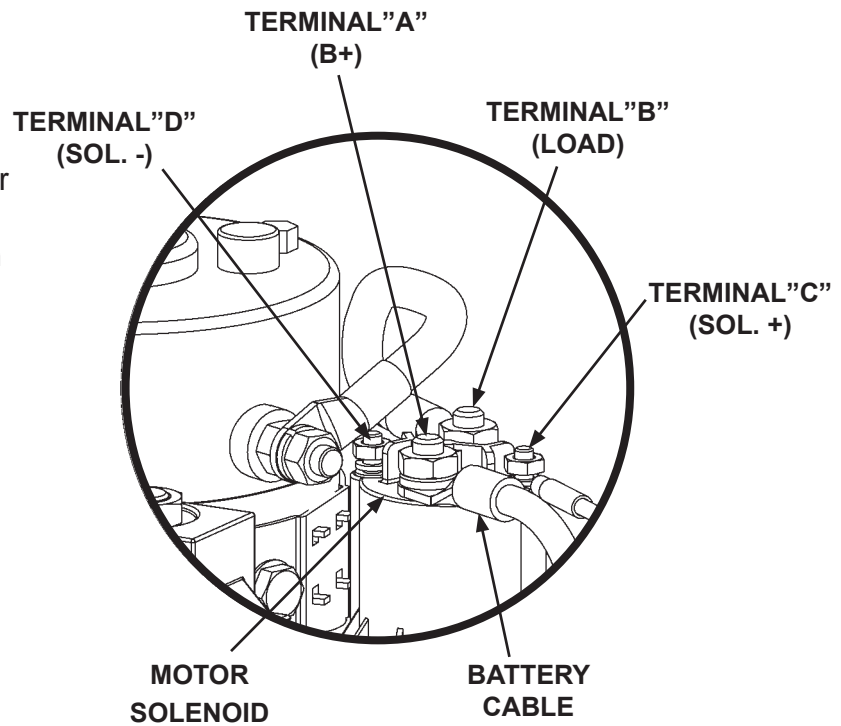

**TYPICAL MOTOR SOLENOID ELECTRICAL CONNECTIONS
(GRAVITY DOWN PUMP IS SHOWN)
FIG. 57-1**

2. Find out if vehicle is equipped with optional battery box, truck charge line, tractor charge line, or trailer charge line. Check optional battery box cables and charge line cables for damage, dirty connections and loose connections. Replace damaged battery cables, clean dirty connections, and tighten loose connections.
3. Check if vehicle batteries and optional battery box batteries are fully charged. If required, fully charge batteries with a battery charger. Replace batteries that cannot be fully charged. If battery charger fully charges batteries, use vehicle manufacturer's specifications to check the vehicle battery charging system. Do not operate Liftgate if vehicle charging system needs repair.
4. Use a 6" long, 10 gauge insulated wire as a jumper to connect pump motor solenoid terminal A and terminal C. Check for 12.6 volts dc output from motor solenoid by using voltmeter between terminal B (**FIG. 57-1**) and ground. If a low voltage or 0 volts is indicated on terminal B, replace motor solenoid. Also, check electrical load cable for damage, dirty connections, and loose connections. Replace cable if damaged, clean dirty connections, and tighten loose connections. Use multimeter and applicable schematics in this manual to check switch controls and interconnecting wiring.

TROUBLESHOOTING

PLATFORM WILL NOT PICK UP RATED CAPACITY

1. Check for unequal cylinder operation (lagging cylinder first).
 - **GRAVITY DOWN LIFTGATES:** Lower the platform to the ground. Disconnect the RETURN HOSE at the bottom of each column. Place a large container under cylinder to catch fluid. Set control box toggle switch to **UP** position to raise platform. Check if fluid is streaming from the fitting. A few drops of hydraulic fluid is okay; however, if fluid streams steadily from the fitting, replace piston seals.
 - **POWER DOWN LIFTGATES:** Raise the platform to bed height. Disconnect both bottom **POWER DOWN RETURN HOSES** at the "T" connector between pump box and bottom of each cylinder. (**Refer to POWER DOWN HYDRAULIC LINES IDENTIFICATION in this manual.**) Place a large container to catch fluid from both hoses. Set control box toggle switch to **UP** position to raise platform. Check if fluid is streaming from the hoses. A few drops of hydraulic fluid is okay; however, if fluid streams steadily from a hose, replace piston seals in the cylinder connected to that hose.
2. Check vehicle charge line cables for damage, dirty connections and loose connections. If Liftgate battery box is installed, check for damaged battery cables, dirty cable connections and loose cable connections in battery box. Replace damaged cables, clean dirty connections and tighten loose connections.
3. Check for bent parts on the Liftgate that could interfere with normal operation.

NOTE: Do the **BLEEDING HYDRAULIC SYSTEM** procedure in this manual with the following step.

4. Verify that relief valve pressure settings are correct. Refer to relief valve pressure setting procedure. If pressure settings can't be corrected or if pump runs hot and excessively noisy, replace pump.

NOTE: Do the **BLEEDING HYDRAULIC SYSTEM** procedure in this manual with the following step.

5. Remove pump assembly from reservoir (**FIG. 58-1**). Check if pump filter is clogged. Clean clogged filter and flush contaminated fluid from reservoir. Replace spin-on filter in pump box. Reinstall pump/motor assembly.

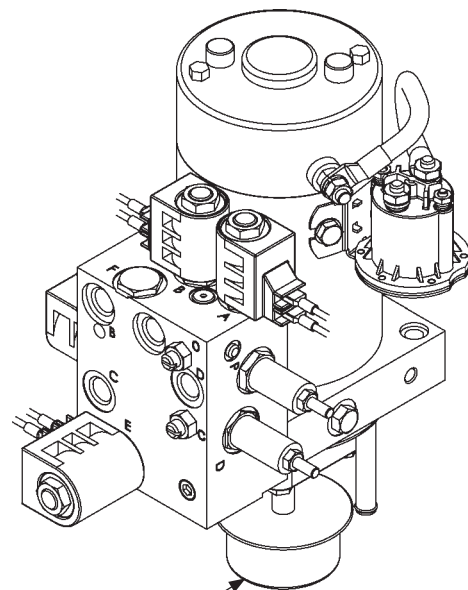

PUMP FILTER

**TYPICAL PUMP REMOVED TO CHECK & CLEAN FILTER
(POWER DOWN PUMP IS SHOWN)
FIG. 58-1**

TROUBLESHOOTING

PLATFORM RAISES HALFWAY & STOPS

1. Check the hydraulic fluid level in the reservoir.

- **GRAVITY DOWN LIFTGATES:** Lower the platform to the ground. Clean dirt and fluid from top of reservoir in pump box. Fill the reservoir to correct level indicated on sight glass (pump box).
- **POWER DOWN LIFTGATES:** Raise the platform to bed height. Fill the reservoir to correct level indicated on sight glass (pump box).

NOTE: For dual pump system, check secondary pump and motor first.

2. Find out if vehicle is equipped with optional battery box, truck charge line, tractor charge line, or trailer charge line. Check optional battery box cables and charge line cables for damage, dirty connections and loose connections. Replace damaged battery cables, clean dirty connections, and tighten loose connections.
3. Check if vehicle batteries and optional battery box batteries are fully charged. If required, fully charge batteries with a battery charger. Replace batteries that cannot fully charge. If battery charger fully charges batteries, use vehicle manufacturer's specifications to check the vehicle battery charging system. Do not operate Liftgate if vehicle charging system needs repair.

4. Check pump motor solenoid (**FIG. 59-1**) and electrical cable connections in pump box. Make sure electrical cable connections are clean and tight. Use a 6" long, 10 gauge insulated wire as a jumper between motor solenoid terminals "A" and "C" to activate solenoid. Replace solenoid if it fails to activate.

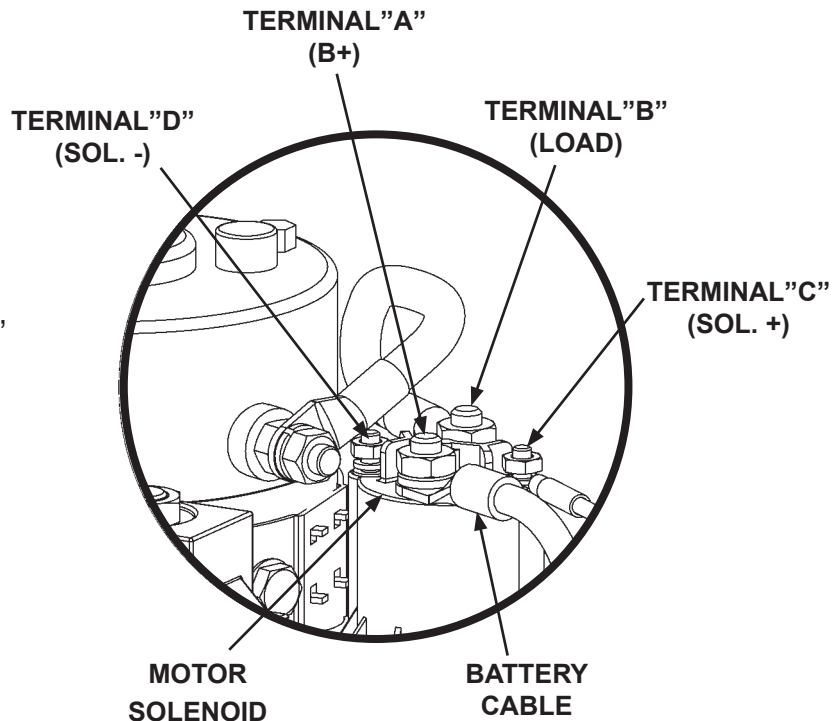

**TYPICAL MOTOR SOLENOID ELECTRICAL CONNECTIONS
(GRAVITY DOWN PUMP IS SHOWN)**

FIG. 59-1

TROUBLESHOOTING PLATFORM RAISES HALFWAY & STOPS - Continued

5. Check for bent parts on the Liftgate that could interfere with normal operation.

NOTE: Do the **BLEEDING HYDRAULIC SYSTEM** procedure in this manual with the following step.

6. Remove assembled pump and motor from reservoir (**FIG. 60-1**). Check if pump filter is clogged. Clean clogged filter and flush contaminated fluid from reservoir. Replace spin-on filter in pump box.

7. If pump runs hot and extremely noisy, replace it.

NOTE: Do the **BLEEDING HYDRAULIC SYSTEM** procedure in this manual with the following step.

8. At the top of each column, loosen nut and disconnect hydraulic line from connector on bottom of flow control valve (**FIG. 60-2**). Check if the flow control valves are contaminated. Try to move plunger with small screwdriver through bottom of connector (**FIG. 60-2**). Replace valve if contaminated or not working.

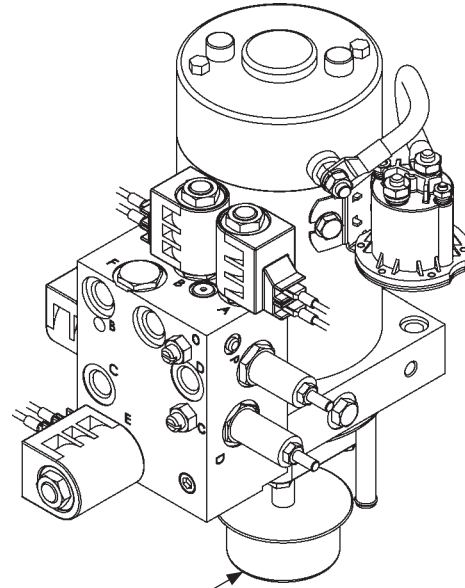

PUMP FILTER

**TYPICAL PUMP REMOVED TO
CHECK & CLEAN FILTER
(POWER DOWN PUMP IS SHOWN)
FIG. 60-1**

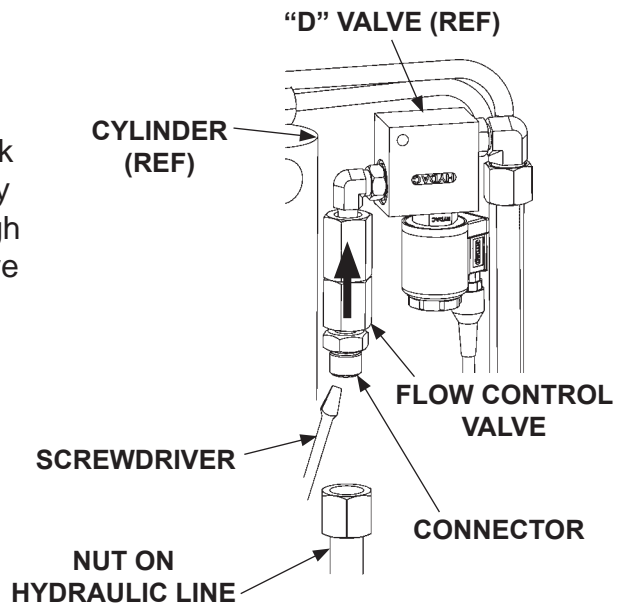

FIG. 60-2

TROUBLESHOOTING

PLATFORM RAISES AND LOWERS UNEVENLY

NOTE: Do the **BLEEDING HYDRAULIC SYSTEM** procedure in this manual with the following step.

1. Reverse the two 3/8" high pressure hose connections on output side of flow divider as shown in **FIG. 61-1**. Raise the platform. If the uneven platform position is the opposite of original symptom, replace flow divider.

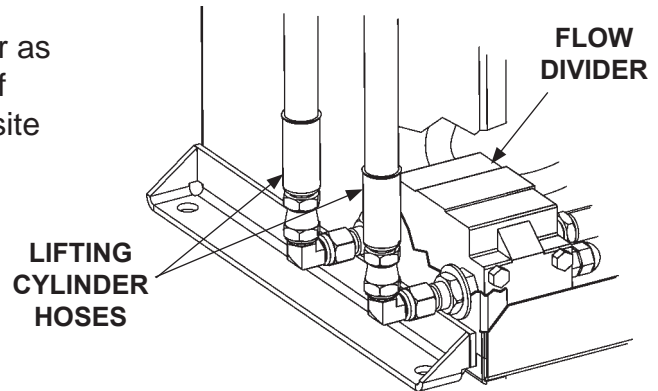

**HOSE CONNECTIONS ON
FLOW DIVIDER
FIG. 61-1**

2. Check each Lifting hydraulic cylinder.
 - **GRAVITY DOWN LIFTGATES:** Lower the platform to the ground. Disconnect the RETURN HOSE at the bottom of each column. Place a large container under cylinder to catch fluid. Set control box toggle switch to **UP** position to raise platform. Check if fluid is streaming from the fitting. A few drops of hydraulic fluid is okay; however, if fluid streams steadily from the fitting, replace piston seals.
 - **POWER DOWN LIFTGATES:** Raise the platform to bed height. Disconnect both bottom **POWER DOWN RETURN HOSES** at the "T" connector between pump box and bottom of each cylinder. (**Refer to POWER DOWN HYDRAULIC LINES IDENTIFICATION in this manual.**) Place a large container to catch fluid from both hoses. Set control box toggle switch to **UP** position to raise platform. Check if fluid is streaming from the hoses. A few drops of hydraulic fluid is okay; however, if fluid streams steadily from a hose, replace piston seals in the cylinder connected to that hose.

NOTE: Do the **BLEEDING HYDRAULIC SYSTEM** procedure in this manual with the following step.

3. Lower the platform to the ground. At the top of each column, loosen nut and disconnect hydraulic line from connector on bottom of flow control valve (**FIG. 62-1**). Check if the flow control valves are contaminated. Try to move plunger with small screwdriver through bottom of connector (**FIG. 62-1**). Replace valve if contaminated or not working.

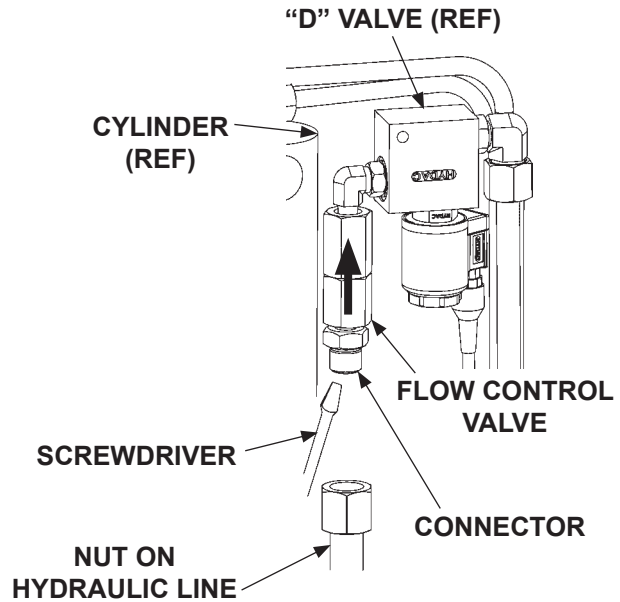

FIG. 62-1

4. Check for bent parts on the Liftgate that could interfere with normal operation.

THIS PAGE INTENTIONALLY LEFT BLANK.

TROUBLESHOOTING

PLATFORM WILL NOT FOLD

1. Check the hydraulic fluid level in the reservoir.

- **GRAVITY DOWN LIFTGATES:** Lower the platform to the ground. Clean dirt and fluid from top of reservoir in pump box. Fill the reservoir to correct level indicated on sight glass (pump box).
- **POWER DOWN LIFTGATES:** Raise the platform to bed height. Fill the reservoir to correct level indicated on sight glass (pump box).

NOTE: For dual pump system, check secondary pump and motor first.

2. Check pump motor solenoid (**FIG. 64-1**) in pump box and bus bar connections in pump box. Make sure bus bar connections are clean and tight. Use a 6" long, 10 gauge insulated wire as a jumper between motor solenoid terminals "C" and "A" to activate solenoid. Replace solenoid if it fails to activate.

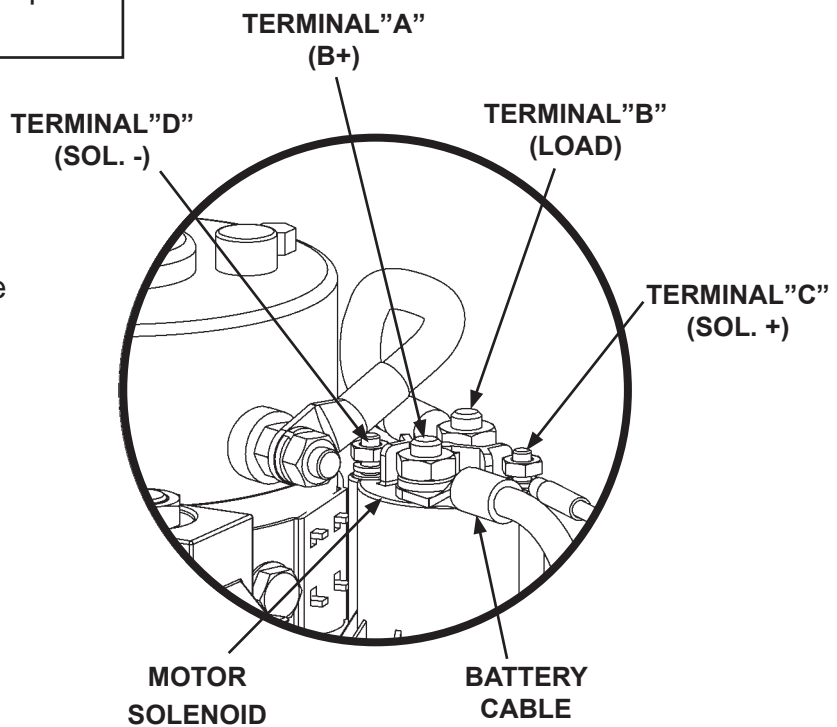

TYPICAL MOTOR SOLENOID ELECTRICAL CONNECTIONS (GRAVITY DOWN PUMP IS SHOWN)
FIG. 64-1

3. Verify that relief valve pressure settings are correct. Refer to **RELIEF VALVE PRESSURE SETTING** procedure in this manual. Also, make sure flow control valve (on pump) is open. Perform platform opening & closing speed adjustment procedure. If pressure settings can't be corrected, if platform opening and closing speed can't be adjusted or if pump runs hot and excessively noisy, replace pump.

TROUBLESHOOTING

PLATFORM WILL NOT FOLD - Continued

⚠ WARNING

Make sure Liftgate platform is open and resting on the ground before performing the following step.

CAUTION

To prevent damage when installing valve cartridges & coils, torque valve cartridge nut to 30 lbs.-in. max.

4. The “E” solenoid valve (**FIG. 65-1**) may be stuck in the “open” position. Remove the “E” solenoid valve (**FIG. 65-2**). Next, check the valve cartridge as follows. Push on the plunger in the valve by inserting small screwdriver in the open end (**FIG. 65-3**). If the plunger does not move with a smooth, spring-loaded action (approximately 1/8”) (**FIG. 65-3**), replace the valve cartridge.

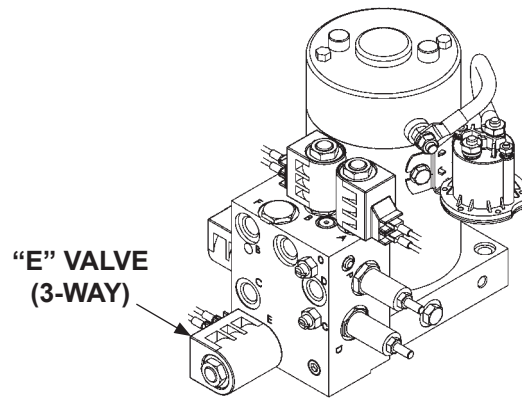

**TYPICAL SOLENOID VALVES
(POWER DOWN PUMP IS SHOWN)
FIG. 65-1**

5. Reinstall “E” solenoid valve (**FIG. 65-1**) (if good) or a replacement. **Torque valve cartridge to 30 lbs.-ft. and hex nut to 30 lbs.-in.**

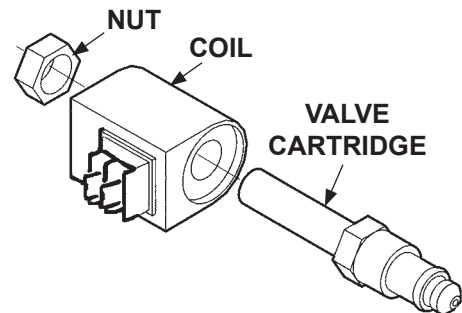

**TYPICAL SOLENOID VALVE
REMOVED & DISASSEMBLED
FIG. 65-2**

6. Check for bent parts on the Liftgate that could interfere with normal operation.

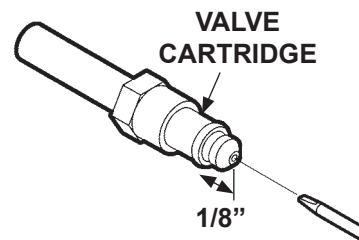

**CHECKING VALVE CARTRIDGE
FIG. 65-3**

7. Check if hydraulic fluid is streaming from breather plug.

TROUBLESHOOTING PLATFORM WILL NOT UNFOLD

⚠ WARNING

Before doing the following procedure, set up guarded area around the platform to keep people from entering.

NOTE: For dual pump system, check secondary pump and motor first.

1. Flow of hydraulic fluid may be restricted. Turn opener (unfolding) valve adjustment (**FIG. 66-1**) counter-clockwise to open the valve. If necessary, do the **PUMP ASSEMBLY PRESSURE SETTING** procedure in this section.

NOTE: Numbers for the electrical terminals are not stamped on the valve coil. Numbers shown in illustration are for reference only.

2. Check if the “A” valve (**FIG. 66-1**) is energized. Connect voltmeter to terminal-1 and terminal-2 as shown in **FIG. 66-1**. Activate the **UNFOLD** toggle switch and **FOLD/UNFOLD** toggle switches. Correct indication is +11 to +12.6 volts dc. If indication is incorrect, check control switch and wiring to “A” valve (refer to **ELECTRICAL SYSTEM DIAGRAMS** section). Replace faulty wiring or control switch as required. If the voltmeter indicates +11 to +12.6 volts dc and “A” valve does not operate, replace “A” valve.

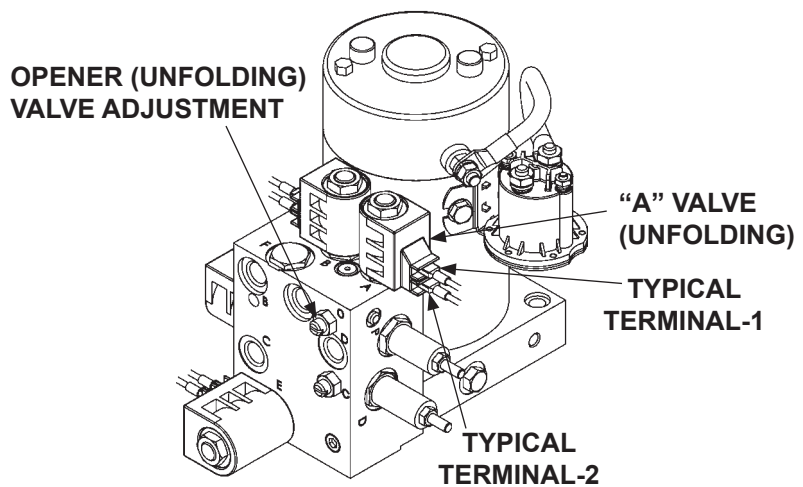

**TYPICAL VALVES & ELECTRICAL CONNECTIONS
(POWER DOWN PUMP IS SHOWN)
FIG. 66-1**

MAXON

11921 Slauson Ave. Santa Fe Springs, CA. 90670 (800) 227-4116 FAX (888) 771-7713

⚠ WARNING

Make sure Liftgate platform is open and resting on the ground before performing the following step.

CAUTION

To prevent damage when installing valve cartridges & coils, torque valve cartridge nut to 30 lbs.-in. max.

- The “E” solenoid valve (FIG. 67-1) may be stuck in the “open” position. Remove the “E” solenoid valve (FIG. 67-2). Next, check the valve cartridge as follows. Push on the plunger in the valve by inserting small screwdriver in the open end (FIG. 67-3). If the plunger does not move with a smooth, spring-loaded action (approximately 1/8”) (FIG. 67-3), replace the valve cartridge.

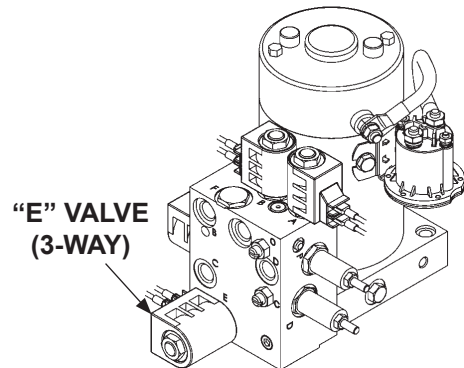

TYPICAL SOLENOID VALVES
(POWER DOWN PUMP IS SHOWN)
FIG. 67-1

- Reinstall “E” solenoid valve (FIG. 67-1) (if good) or a replacement. Torque valve cartridge to 30 lbs.-ft. and hex nut to 30 lbs.-in.
- Verify that relief valve pressure settings are correct. Refer to **RELIEF VALVE PRESSURE SETTING** procedure in this manual. Also, make sure opening flow control valve (in pump) is open. If correct pressure settings cannot be made or if pump runs hot with excessive noise, replace pump.
- Check for damage and corrosion at platform pivot points. Steam clean corrosion from pivot points. Replace bushings at pivot points if required.

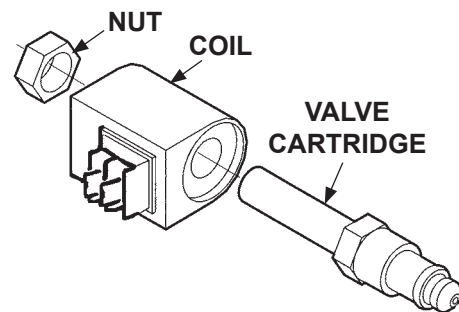

TYPICAL SOLENOID VALVE
REMOVED & DISASSEMBLED
FIG. 67-2

- Check for bent and broken parts on the Liftgate that could interfere with normal operation. Look at columns, runners, tandem rollers and platform (bent pins).

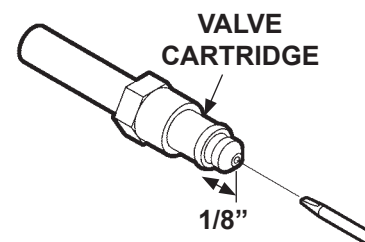

CHECKING VALVE CARTRIDGE
FIG. 67-3

- Check for bent or weak platform torsion spring. Replace if necessary.

TROUBLESHOOTING

PUMP RELIEF VALVE PRESSURE SETTING

NOTE: The pump pressure is set at the factory; however, if adjustment is needed, use the following procedure.

1. Open the platform. Turn closer valve adjustment (**FIG. 68-1**) all the way clockwise. Disconnect hose from folding port bulkhead fitting and connect 0-3000 PSI gauge to hose (**FIG. 68-1**).

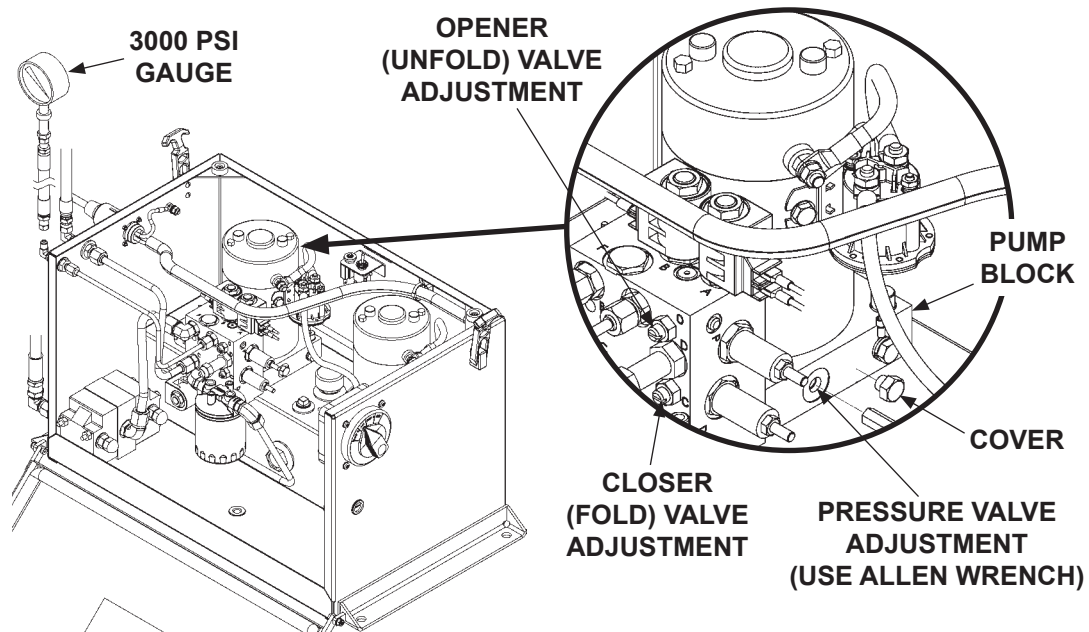

**CONNECTING PRESSURE GAUGE -
(POWER DOWN DUAL PUMP IS SHOWN)
FIG. 68-1**

2. Remove cover (covering pump pressure relief valve) from pump block (**FIG. 68-1**). Set Liftgate control box to **FOLD**. Turn the pump pressure relief valve (**FIG. 68-1**) to obtain proper pump pressure setting of **2750 PSI**. Reinstall cover.
3. If this is a dual pump system, do the following. Once pump 1 is set, select pump 2 with pump select switch (**FIG. 68-1**). Repeat **Steps 1 and 2** for pump 2.
4. Disconnect 0-3000 PSI gauge from hose (**FIG. 68-1**) and reconnect hose to folding port bulkhead fitting.
5. Reset the closer valve adjustment (**FIG. 68-1**) to obtain platform closing speed cycle of 4-6 seconds.

MAXON[®]

11921 Slauson Ave. Santa Fe Springs, CA. 90670 (800) 227-4116 FAX (888) 771-7713

TROUBLESHOOTING - GRAVITY DOWN PLATFORM WILL NOT RAISE, MOTOR RUNS

1. Check the hydraulic fluid level in the reservoir.
 - **GRAVITY DOWN LIFTGATES:** Lower the platform to the ground. Clean dirt and fluid from top of reservoir in pump box. Fill the reservoir to correct level indicated on sight glass (pump box).
 - **POWER DOWN LIFTGATES:** Raise the platform to bed height. Fill the reservoir to correct level indicated on sight glass (pump box).
2. Check for bent parts on the Liftgate that could interfere with normal operation. Look at columns, runners, and tandem rollers.

⚠ WARNING

Make sure Liftgate platform is open and resting on the ground before performing the following step.

NOTE: For dual pump system, check secondary pump and motor first.

3. Check the high pressure relief valve (**FIG. 69-1**) for contamination or defective operation. Lower the platform to the ground. Remove the relief valve. Clean or replace valve as required.

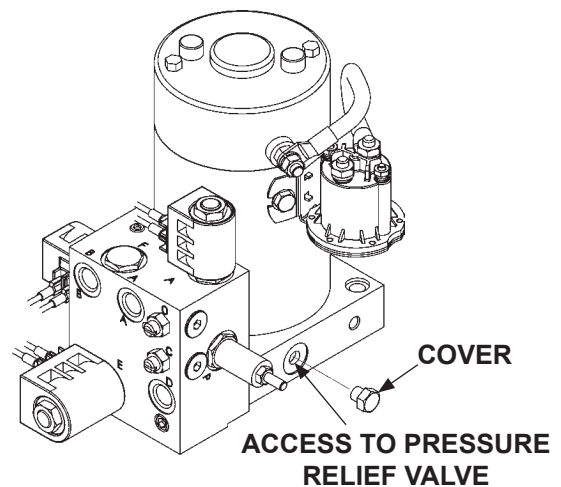

**CHECKING PRESSURE RELIEF VALVE
(GRAVITY DOWN PUMP IS SHOWN)
FIG. 69-1**

4. Adjust relief valve operating pressure according to **PUMP RELIEF VALVE PRESSURE SETTING** procedure.

TROUBLESHOOTING - GRAVITY DOWN PLATFORM WILL NOT LOWER

NOTE: For dual pump system, check secondary pump and motor first.

NOTE: Numbers for the electrical terminals shown in the illustration are not stamped on valve coil. Numbers shown are for reference only.

1. Try lowering platform (activate **DOWN** toggle switch). Only the motor solenoid and "B" valve (both located in the pump box) (**FIG. 70-1**) and "D" valve (on top of LH and RH columns) (**FIG. 70-2**) should be energized while lowering platform. Connect voltmeter to terminal-1 and terminal-2 on each valve shown in **FIG. 70-1**. Correct indication for "B" and "D" valves is +11 to +12.6 volts dc. If indications are incorrect, check control switch and wiring to that valve (refer to **ELECTRICAL SYSTEM DIAGRAMS** section). Replace faulty wiring or control switch as required.

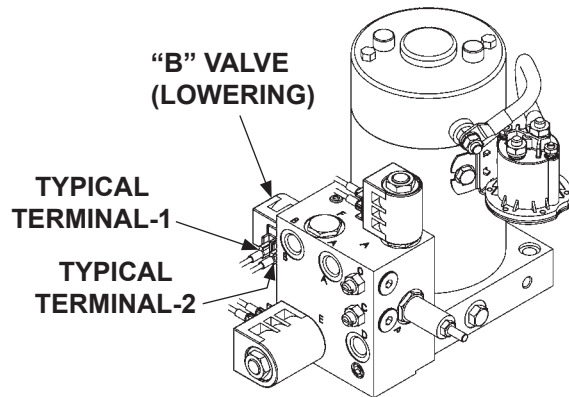

**TYPICAL SOLENOID VALVES
(GRAVITY DOWN PUMP IS SHOWN)
FIG. 70-1**

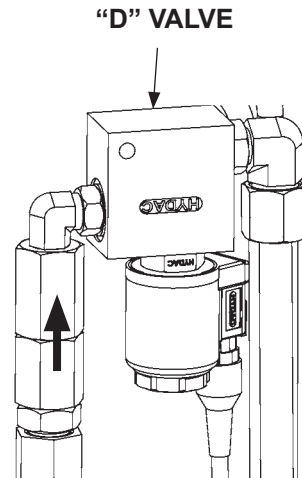

**"D" VALVE
FIG. 70-2**

MAXON[®]

11921 Slauson Ave. Santa Fe Springs, CA. 90670 (800) 227-4116 FAX (888) 771-7713

⚠ WARNING

Make sure Liftgate platform is open and resting on the ground before performing the following step.

CAUTION

To prevent damage when installing valve cartridges & coils, torque valve cartridge nut to 30 lbs.-in. max.

NOTE: Do the **BLEEDING HYDRAULIC SYSTEM** procedure in this manual with the following step.

2. Lower the platform to the ground. At the top of each column, loosen nut and disconnect hydraulic line from connector on bottom of flow control valve (**FIG. 71-1**). Check if the flow control valves are contaminated. Try to move plunger with small screwdriver through bottom of connector (**FIG. 71-1**). Replace valve if contaminated or not working.

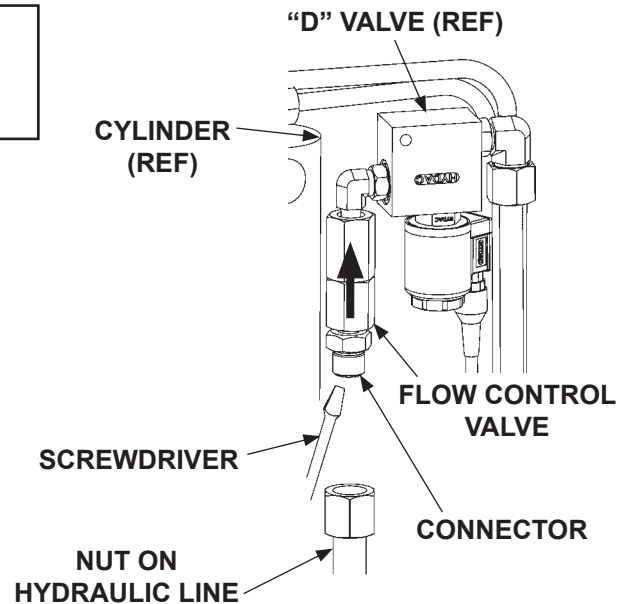

FIG. 71-1

TROUBLESHOOTING - GRAVITY DOWN PLATFORM LOWERS SLOWLY

NOTE: For dual pump system, check secondary pump and motor first.

NOTE: Numbers for the electrical terminals shown in the illustration are not stamped on valve coil. Numbers shown are for reference only.

1. Check if the “B” solenoid valve coil (**FIG. 72-1**) (located in the pump box) is getting power. Connect voltmeter to terminal-1 and terminal-2 of the coil. Activate the **DOWN** toggle switch. Correct indication is +11 to +12.6 volts dc. If the voltmeter does not indicate +11 to +12.6 volts dc, check control switch and wiring to “B” solenoid valve (refer to **ELECTRICAL SYSTEM DIAGRAMS** section). Replace faulty wiring or control switch as required. If the voltmeter indicates +11 to +12.6 volts dc and valve still does not operate, replace the valve.

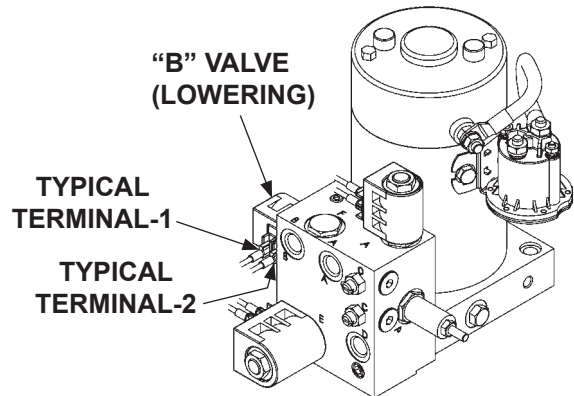

**TYPICAL SOLENOID VALVES
(GRAVITY DOWN PUMP IS SHOWN)
FIG. 72-1**

⚠ WARNING

Make sure Liftgate platform is open and resting on the ground before performing the following step.

CAUTION

To prevent damage when installing valve cartridges & coils, torque valve cartridge nut to 30 lbs.-in. max.

2. The “B” solenoid valve (**FIG. 72-1**) may be stuck in the “open” position. Remove the “B” solenoid valve (**FIG. 72-2**). Next, check the valve cartridge as follows. Push on the plunger in the valve by inserting small screwdriver in the open end (**FIG. 73-1**). If the plunger does not move with a smooth, spring-loaded action (approximately 1/8”), replace the valve cartridge.

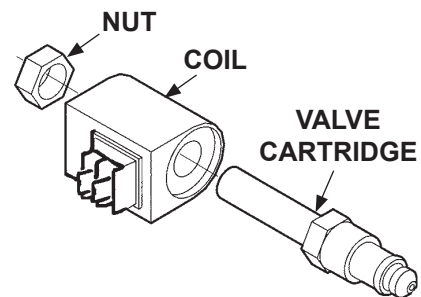

**TYPICAL SOLENOID VALVE
REMOVED & DISASSEMBLED
FIG. 72-2**

3. Reinstall "B" solenoid valve (if good) (**FIG. 73-1**) or a replacement. **Torque valve cartridge to 30 lbs.-ft. and hex nut to 30 lbs.-in.**

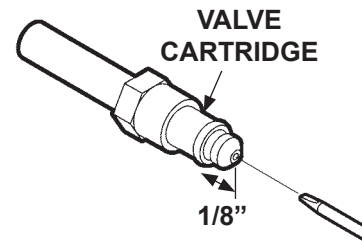

**CHECKING VALVE CARTRIDGE
FIG. 73-1**

4. Check for bent and broken parts on the Liftgate that could interfere with normal operation.
5. Check both flow control valves. Refer to the flow control valve instructions in the procedure for **PLATFORM RAISES AND LOWERS UNEVENLY.**

TROUBLESHOOTING - POWER DOWN

PLATFORM WILL NOT RAISE, MOTOR RUNS

1. Check the hydraulic fluid level in the reservoir.

- **GRAVITY DOWN LIFTGATES:** Lower the platform to the ground. Clean dirt and fluid from top of reservoir in pump box. Fill the reservoir to correct level indicated on sight glass (pump box).
- **POWER DOWN LIFTGATES:** Raise the platform to bed height. Fill the reservoir to correct level indicated on sight glass (pump box).

NOTE: For dual pump system, check secondary pump and motor first.

NOTE: Numbers for the electrical terminals shown in the illustration are not stamped on valve coil. Numbers shown are for reference only.

2. Try raising platform (activate **UP** toggle switch). Only the motor solenoid (**FIG. 74-1**) should be energized while raising platform. The "A", "B", "C" and "E" solenoid valves (**FIG. 74-1**) (located in the pump box) should not be energized. Connect voltmeter to terminal-1 and terminal-2 on each valve shown in **FIG. 74-1**. Correct indication is 0 volts dc. If voltmeter indicates +11 to +12.6 volts dc for any of the valves, check control switch and wiring to the valve (refer to **ELECTRICAL SYSTEM DIAGRAMS** section). Replace faulty wiring or control switch as required.

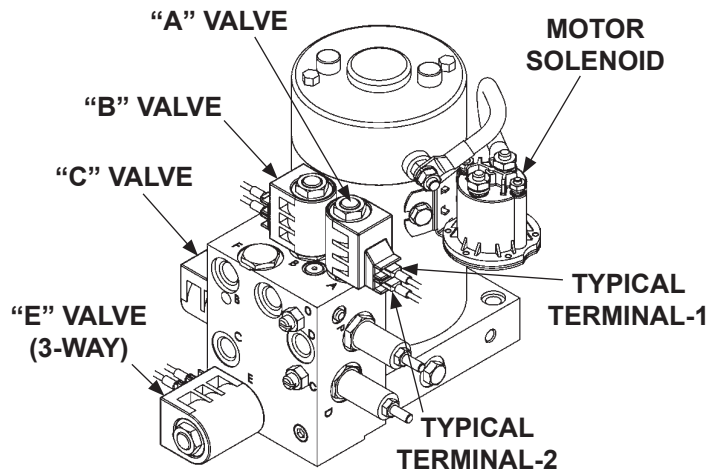

**VALVES & ELECTRICAL CONNECTIONS
FOR POWER DOWN PUMP
FIG. 74-1**

MAXON[®]

11921 Slauson Ave. Santa Fe Springs, CA. 90670 (800) 227-4116 FAX (888) 771-7713

⚠ WARNING

Make sure Liftgate platform is open and resting on the ground before performing the following step.

CAUTION

To prevent damage when installing valve cartridges & coils, torque valve cartridge nut to 30 lbs.-in. max.

- The “E” solenoid valve (**FIG. 75-1**) may be stuck in the “open” position. Remove the “E” solenoid valve (**FIG. 75-2**). Next, check the valve cartridge as follows. Push on the plunger in the valve by inserting small screwdriver in the open end (**FIG. 75-3**). If the plunger does not move with a smooth, spring-loaded action (approximately 1/8”) (**FIG. 75-3**), replace the valve cartridge.

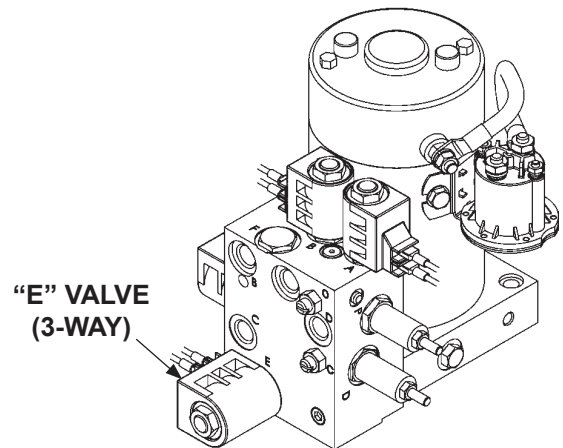

**POWER DOWN PUMP
FIG. 75-1**

- Reinstall “E” solenoid valve (if good) (**FIG. 75-2**) or a replacement. Torque valve cartridge to 30 lbs.-ft. and hex nut to 30 lbs.-in.

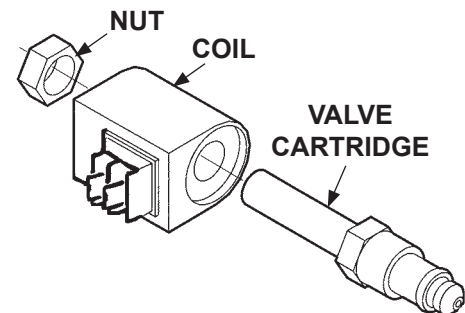

**TYPICAL SOLENOID VALVE
REMOVED & DISASSEMBLED
FIG. 75-2**

- Check for bent and broken parts on the Liftgate that could interfere with normal operation.

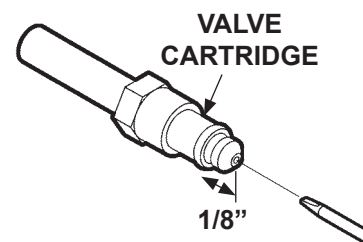

**CHECKING VALVE CARTRIDGE
FIG. 75-3**

TROUBLESHOOTING - POWER DOWN PLATFORM WILL NOT LOWER

NOTE: For dual pump system, check secondary pump and motor first.

NOTE: Numbers for the electrical terminals shown in the illustration are not stamped on valve coil. Numbers shown are for reference only.

1. Try lowering platform (activate **DOWN** toggle switch). Only the motor solenoid, "B" solenoid valve and "C" solenoid valve (located in the pump box) (**FIG. 76-1**) and "D" solenoid valve (on top of LH and RH columns) (**FIG. 76-2**) should be energized while lowering platform. The "A" and "E" solenoid valves should not be energized. Connect voltmeter to terminal-1 and terminal-2 on each valve shown in **FIG. 76-1**. Correct indication for "A" and "E" solenoid valves is 0 volts dc. For "B", "C" and "D" solenoid valves correct indication is +11 to +12.6 volts dc. If any indications are incorrect, check control switch and wiring to that valve (refer to **ELECTRICAL SYSTEM DIAGRAMS** section). Replace faulty wiring or control switch as required.

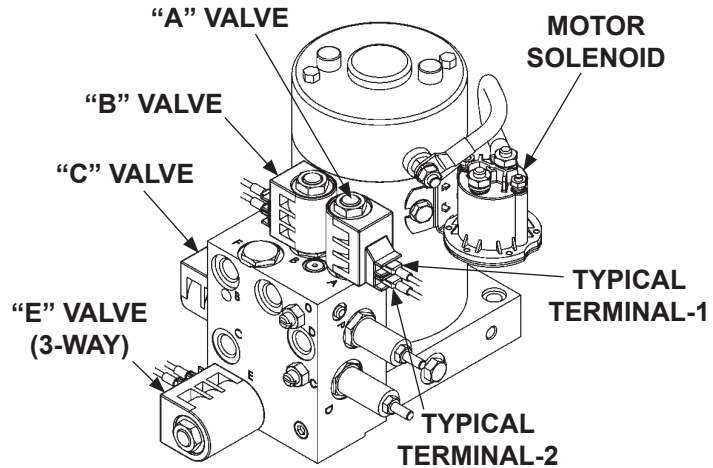

**POWER DOWN PUMP
FIG. 76-1**

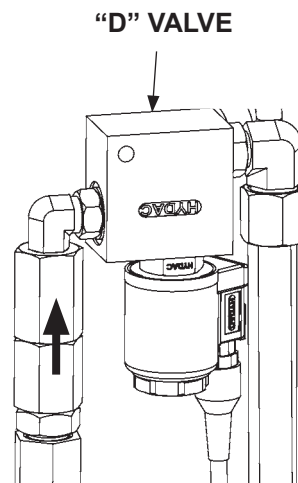

**"D" VALVE
FIG. 76-2**

⚠ WARNING

Make sure Liftgate platform is open and resting on the ground before performing the following step.

CAUTION

To prevent damage when installing valve cartridges & coils, torque valve cartridge nut to 30 lbs.-in. max.

NOTE: Do the **BLEEDING HYDRAULIC SYSTEM** procedure in this manual with the following step.

2. Lower the platform to the ground. At the top of each column, loosen nut and disconnect hydraulic line from connector on bottom of flow control valve (**FIG. 77-1**). Check if the flow control valves are contaminated. Try to move plunger with small screwdriver through bottom of connector (**FIG. 77-1**). Replace valve if contaminated or not working.

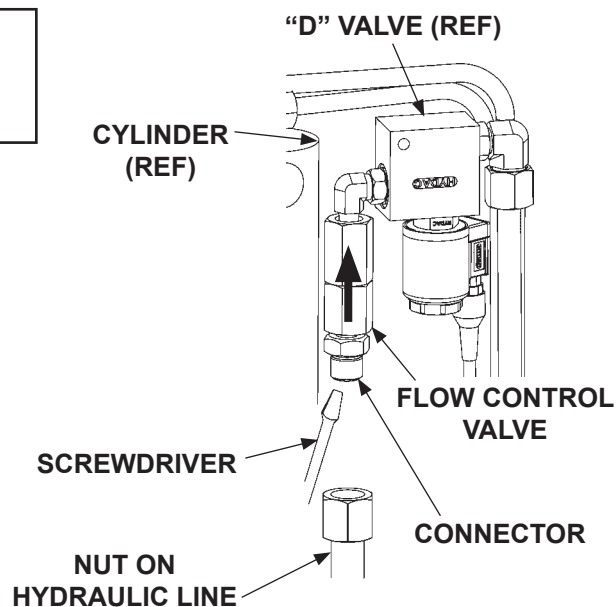

FIG. 77-1

TROUBLESHOOTING - POWER DOWN PLATFORM LOWERS SLOWLY

NOTE: For dual pump system, check secondary pump and motor first.

NOTE: Numbers for the electrical terminals shown in the illustration are not stamped on valve coil. Numbers shown are for reference only.

1. Try lowering platform (activate **DOWN** toggle switch). Make sure motor solenoid (located in the pump box) (**FIG. 78-1**) is energized and "E" solenoid valve is not energized while lowering platform. Connect voltmeter to terminal-1 and terminal-2 on "E" solenoid valve shown in **FIG. 78-1**. The correct indication on voltmeter is 0 volts dc when "E" valve is not energized. If the voltmeter indicates +11 to +12.6 volts dc, check control switch and wiring to that valve (refer to **ELECTRICAL SYSTEM DIAGRAMS** section). Replace faulty wiring or control switch as required.

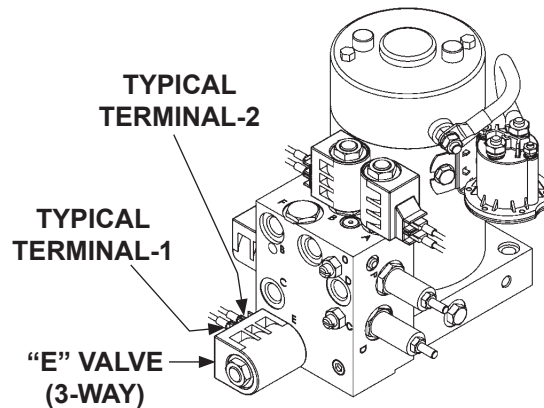

**VALVES & ELECTRICAL CONNECTIONS
FOR POWER DOWN PUMP
FIG. 78-1**

⚠ WARNING

Make sure Liftgate platform is open and resting on the ground before performing the following step.

CAUTION

To prevent damage when installing valve cartridges & coils, torque valve cartridge nut to 30 lbs.-in. max.

2. The "E" solenoid valve (**FIG. 78-1**) may be stuck in the "open" position. Remove the "E" solenoid valve (**FIG. 79-1**). Next, check the valve cartridge as follows. Push on the plunger in the valve by inserting small screwdriver in the open end (**FIG. 79-2**). If the plunger does not move with a smooth, spring-loaded action (approximately 1/8") (**FIG. 79-2**), replace the valve cartridge.

MAXON

11921 Slauson Ave. Santa Fe Springs, CA. 90670 (800) 227-4116 FAX (888) 771-7713

3. Reinstall “E” solenoid valve (if good) (**FIG. 79-1**) or a replacement. **Torque valve cartridge to 30 lbs.-ft. and hex nut to 30 lbs.-in.**

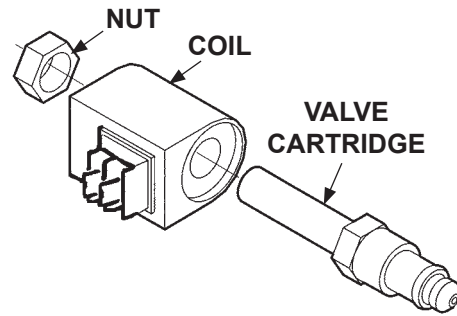

**TYPICAL SOLENOID VALVE
REMOVED & DISASSEMBLED
FIG. 79-1**

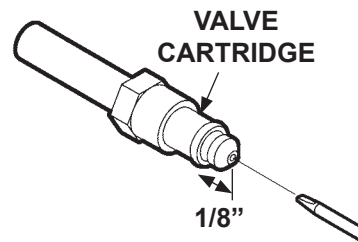

**CHECKING VALVE CARTRIDGE
FIG. 79-2**

4. Check for bent and broken parts on the Liftgate that could interfere with normal operation.
5. Check both flow control valves. Refer to the flow control valve instructions in the procedure for **PLATFORM RAISES AND LOWERS UNEVENLY.**

