

M-06-16
JULY 2006

MAXON[®]

GPTWR-3

MAINTENANCE MANUAL

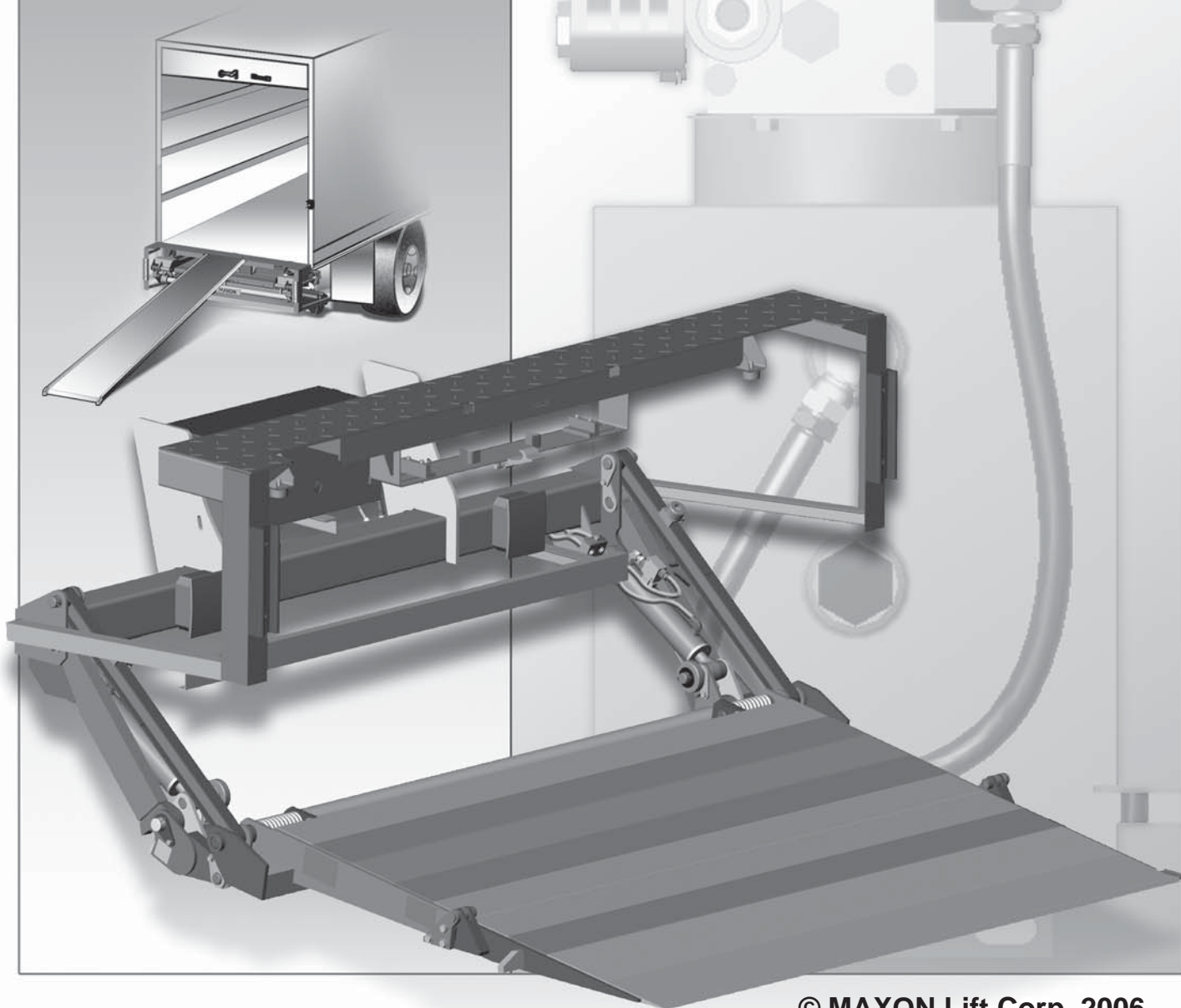

© MAXON Lift Corp. 2006

MAXON[®]

LIFT CORP.

11921 Slauson Ave.
Santa Fe Springs, CA. 90670

CUSTOMER SERVICE:

TELEPHONE (562) 464-0099 TOLL FREE (800) 227-4116

FAX: (888) 771-7713

NOTE: For latest version of all Manuals (and replacements), download the Manuals from Maxon's website at www.maxonlift.com.

WARRANTY/ RMA POLICY & PROCEDURE

LIFTGATE WARRANTY

Type of Warranty: Full Parts and Labor

Term of Warranty: Standard Liftgates - 2 years from ship date or 6,000 cycles
Premium Liftgates - 2 years from ship date or 10,000 cycles

This warranty shall not apply unless the product is installed, operated and maintained in accordance with MAXON Lift's specifications as set forth in MAXON Lift's Installation, Operation and Maintenance manuals. This warranty does not cover normal wear, maintenance or adjustments, damage or malfunction caused by improper handling, installation, abuse, misuse, negligence, or carelessness of operation. In addition, this warranty does not cover equipment that has had unauthorized modifications or alterations made to the product.

MAXON agrees to replace any components which are found to be defective during the first 2 years of service, and will reimburse for labor based on MAXON's Liftgate Warranty Flat Rate Schedule. (Copy of the Flat Rate is available at www.maxonlift.com.)

All warranty repairs must be performed by an authorized MAXON warranty facility. For any repairs that may exceed \$500, including parts and labor, MAXON's Technical Service Department must be notified and an "Authorization Number" obtained.

All claims for warranty must be received within 30 Days of the repair date, and include the following information:

1. Liftgate Model Number and Serial Number
2. The End User must be referenced on the claim
3. Detailed Description of Problem
4. Corrective Action Taken, and Date of Repair
5. Parts used for Repair, Including MAXON Part Number(s)
6. MAXON R.M.A. # and/or Authorization # if applicable (see below)
7. Person contacted at MAXON if applicable
8. Claim must show detailed information i.e. Labor rate and hours of work performed

Warranty claims can also be placed on-line at www.maxonlift.com. On-line claims will be given priority processing.

All claims for warranty will be denied if paperwork has not been received or claim submitted via Maxon website for processing by MAXON's Warranty Department within 30 days of repair date.

All components may be subject to return for inspection, prior to the claim being processed. MAXON products may not be returned without prior written approval from MAXON's Technical Service Department. Returns must be accompanied by a copy of the original invoice or reference with original invoice number and are subject to a credit deduction to cover handling charges and any necessary reconditioning costs. **Unauthorized returns will be refused and will become the responsibility of the returnee.**

Any goods being returned to MAXON Lift must be pre-approved for return, and have the R.M.A. number written on the outside of the package in plain view, and returned freight prepaid. All returns are subject to a 15% handling charge if not accompanied by a detailed packing list. Returned parts are subject to no credit and returned back to the customer.

Defective Parts requested for return must be returned within 30 days of the claim date for consideration to:

MAXON Lift Corp.
16205 Distribution Way, Cerritos, CA 90703
Attn: RMA# _____

MAXON's warranty policy does not include the reimbursement for travel time, towing, vehicle rental, service calls, oil, batteries or loss of income due to downtime. Fabrication or use of non Maxon parts, which are available from MAXON, are also not covered.

MAXON's Flat Rate Labor Schedule takes into consideration the time required for diagnosis of a problem.

All Liftgates returned are subject to inspection and a 15% restocking fee. Any returned Liftgates or components that have been installed or not returned in new condition will be subject to an additional reworking charge which will be based upon the labor and material cost required to return the Liftgate or component to new condition.

PURCHASE PART WARRANTY

Term of Warranty: 1 Year from Date of Purchase.

Type of Warranty: Part replacement only

will guarantee all returned genuine MAXON replacement parts upon receipt and inspection of parts and original invoice.

All warranty replacements parts will be sent out via ground freight. If a Rush Shipment is requested all freight charges will be billed to the requesting party.

MAXON

TABLE OF CONTENTS

WARNINGS	6
LIFTGATE TERMINOLOGY	7
PERIODIC MAINTENANCE	8
PERIODIC MAINTENANCE CHECKS.....	8
PERIODIC MAINTENANCE CHECKLIST	9
CHECKING HYDRAULIC FLUID.....	10
CHANGING HYDRAULIC FLUID	12
REPLACING PLATFORM TORSION SPRING	13
PLATFORM ADJUSTMENT.....	14
PARTS BREAKDOWN	16
MAIN ASSEMBLY (ALUMINUM PLATFORM).....	16
EXTENSION PLATE ASSEMBLY	17
MAIN FRAME ASSEMBLY.....	18
PLATFORM & FLIPOVER ASSEMBLY (ALUMINUM)	22
PLATFORM ASSEMBLY (ALUMINUM)	24
DOCK BUMPER	26
HYDRAULIC COMPONENTS - POWER DOWN	28
POWER UNIT - POWER DOWN.....	30
PUMP BOX ASSEMBLY - POWER DOWN.....	32
CONTROL SWITCH AND POWER CABLE	33
DECALS	34
SYSTEM DIAGRAMS	38
HYDRAULIC SCHEMATIC - POWER DOWN.....	38
ELECTRICAL SCHEMATIC - POWER DOWN	39

TROUBLESHOOTING	40
PLATFORM WILL NOT RAISE	40
PLATFORM RAISES BUT LEAKS DOWN	41
PLATFORM RAISES PARTIALLY AND STOPS.....	42
LIFTGATE WILL NOT LIFT RATED CAPACITY	43
PLATFORM RAISES SLOWLY.....	44
PLATFORM WILL NOT LOWER, LOWERS TOO SLOWLY, OR LOWERS TOO QUICKLY	46
PLATFORM WON'T TILT DOWN TO THE GROUND.....	48

Comply with the following **WARNINGS** while maintaining Liftgates. See Operation Manual for operating safety requirements.

WARNING

- Read and understand the instructions in this **Maintenance Manual** before performing maintenance on the Liftgate.
- Before operating the Liftgate, read and understand the operating instructions in **Operation Manual**.
- Comply with all **WARNING** and instruction decals attached to the Liftgate.
- Keep decals clean and legible. If decals are defaced or missing, replace them. Free replacement decals are available from **Maxon Parts Department**.
- Consider the safety and location of bystanders and location of nearby objects when operating the Liftgate. Stand to one side of the platform while operating the Liftgate
- Do not allow untrained persons to operate the Liftgate.
- Do not stand under, or allow obstructions under the platform when lowering the Liftgate. **Be sure your feet are clear of the Liftgate.**
- **Keep fingers, hands, arms, legs, and feet clear of moving Liftgate parts (and platform edges) when operating the Liftgate.**
- **Correctly stow platform when not in use. Extended platforms could create a hazard for people and vehicles passing by.**
- **Disconnect Liftgate power cable from battery** before repairing or servicing Liftgate.
- Wear appropriate safety equipment such as protective eyeglasses, faceshield and clothing while performing maintenance on the Liftgate and handling the battery. Debris from drilling and contact with battery acid may injure unprotected eyes and skin.
- Be careful working by an automotive type battery. Make sure the work area is well ventilated and there are no flames or sparks near the battery. Never lay objects on the battery that can short the terminals together. If battery acid gets in your eyes, immediately seek first aid. If acid gets on your skin, immediately wash it off with soap and water.
- If an emergency situation arises (vehicle or Liftgate) while operating the Liftgate, release the control Toggle Switch and the Liftgate will stop.
- A correctly installed Liftgate operates smoothly and reasonably quiet. The only noticeable noise during operation comes from the pump unit while the platform is raised. Listen for scraping, grating and binding noises and correct the problem before continuing to operate Liftgate.
- If it is necessary to stand on the platform while maintaining the Liftgate, keep your feet and any objects clear of the inboard edge of the platform. Your feet or objects on the platform could be trapped between the platform and the Liftgate extension plate.
- Never perform unauthorized modifications on the Liftgate. Modifications may result in early failure of the Liftgate and may create hazards for Liftgate operators and maintainers.
- Use only **Maxon Authorized Parts** for replacement parts. Provide Liftgate model and serial number information with your parts order. Order replacement parts from:

MAXON LIFT CORP. Customer Service
11921 Slauson Ave., Santa Fe Springs, CA 90670
Phone: (800) 227-4116

- To order parts by e-mail, submit orders to partssales@maxonlift.com.

MAXON[®]

11921 Slauson Ave. Santa Fe Springs, CA. 90670 (800) 227-4116 FAX (888) 771-7713

LIFTGATE TERMINOLOGY

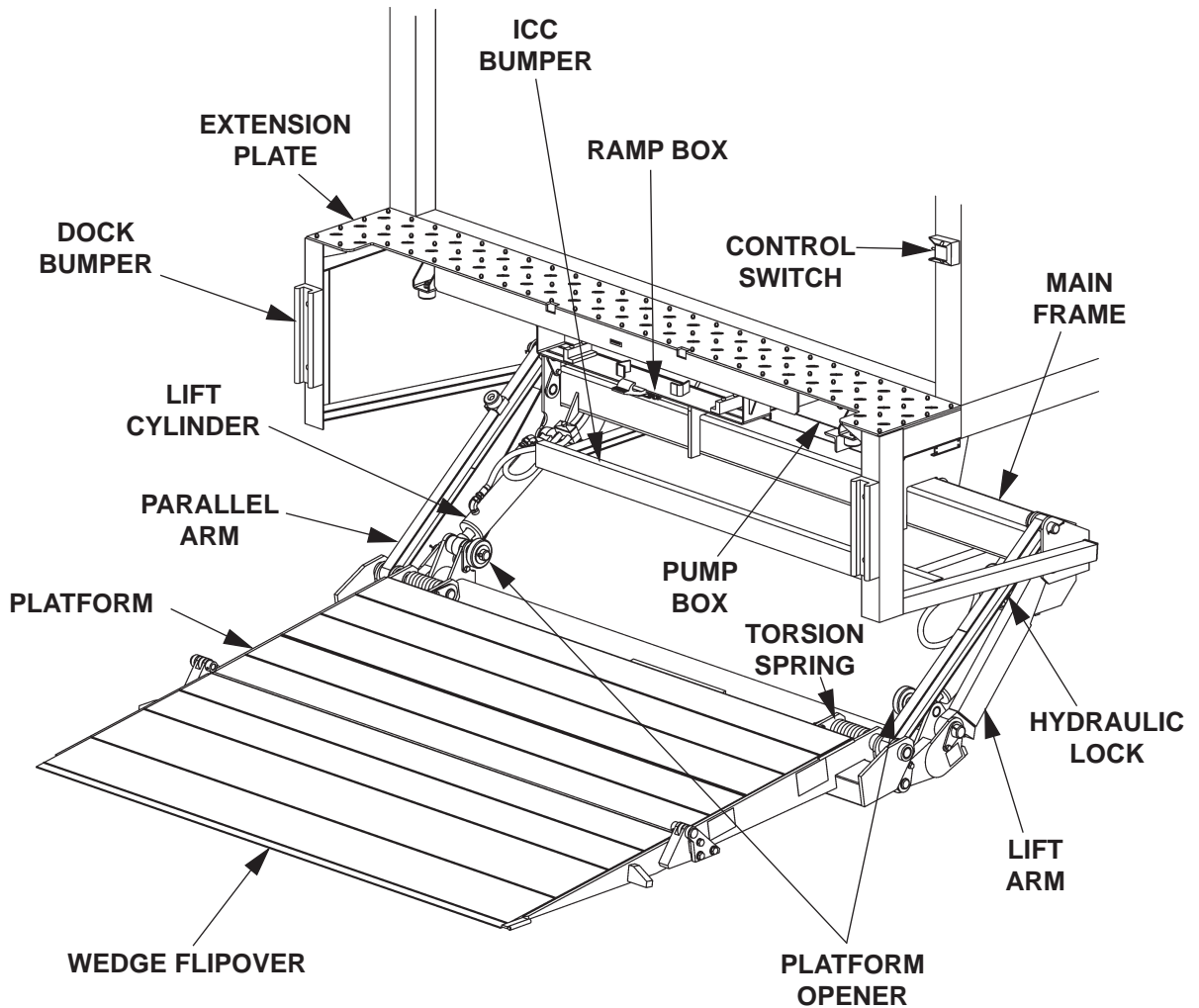

PERIODIC MAINTENANCE

PERIODIC MAINTENANCE CHECKS

WARNING

Never operate the Liftgate if parts are loose or missing.

NOTE: Make sure Vehicle is parked on level ground while performing the maintenance checks.

Quarterly or 1250 Cycles (whichever occurs first)

Check the Hydraulic Fluid level in the Pump Reservoir. Refer to the **CHECKING HYDRAULIC FLUID** procedure in the **PERIODIC MAINTENANCE** section.

If Hydraulic Fluid appears contaminated, refer to the **CHANGING HYDRAULIC FLUID** procedure in the **PERIODIC MAINTENANCE** section.

Keep track of the grade of Hydraulic Fluid in the Pump Reservoir and never mix two different grades of fluid.

Check all Hoses and Fittings for chafing and fluid leaks. Make sure Hydraulic Lock is in place and undamaged. Replace if necessary.

Check electrical wiring for chafing and make sure wiring connections are tight and free of corrosion. Use Dielectric Grease to protect electrical connections.

Check that all **WARNING and instruction decals** are in place. Also make sure decals are readable and decals are clean and undamaged.

Check that all bolts, nuts, and roll pins are in place. Make sure roll pins protrude evenly from both sides of Hinge Pin collar. Replace fasteners and roll pins if necessary.

Check for rust and oily surfaces on Liftgate. If there is rust or oil on Liftgate or if the Liftgate is dirty, clean it off. Touch up the paint where bare metal is showing.

Semi-annually or 2500 Cycles (whichever occurs first)

Visually check the Platform Hinge Pins for excessive wear and broken welds. See **PARTS BREAKDOWN** section for replacement parts. Also, do the **Quarterly or 1250 Cycles** maintenance checks.

MAXON[®]

11921 Slauson Ave. Santa Fe Springs, CA. 90670 (800) 227-4116 FAX (888) 771-7713

PERIODIC MAINTENANCE CHECKLIST

NOTE: Make sure Vehicle is parked on level ground while performing maintenance checks.

Quarterly or 1250 Cycles (whichever occurs first)

- Check the level and condition of the Hydraulic Fluid .
- Visually check all Hoses and Fittings for chafing and fluid leaks. Make sure Hydraulic Lock is in place and undamaged. Tighten loose fittings or replace parts as required.
- Check electrical wiring for chafing and make sure wiring connections are tight and free of corrosion. Use Dielectric Grease to protect electrical connections.
- Check that all **WARNING and instruction decals** are in place. Also make sure decals are readable and decals are clean and undamaged.
- Check that all bolts, nuts, and roll pins are in place. Make sure roll pins protrude evenly from both sides of Hinge Pin collar. Replace fasteners and roll pins if necessary.
- Check for rust and oily surfaces on Liftgate. If there is rust or oil on Liftgate or if the Liftgate is dirty, clean it off. Touch up the paint where bare metal is showing.

Semi-annually or 2500 Cycles (whichever occurs first)

- Visually check the Platform Hinge Pins for excessive wear and broken welds.
- Do the **Quarterly or 1250 Cycles Checks** on this Checklist.

PERIODIC MAINTENANCE

CHECKING HYDRAULIC FLUID

CAUTION

Keep dirt, water and other contaminants from entering the hydraulic system. Before opening the hydraulic fluid reservoir filler cap, drain plug and hydraulic lines, clean up contaminants that can get in the openings. Also, protect the openings from accidental contamination.

NOTE: Use correct grade of hydraulic fluid for your location.

+70 to +140 Degrees F - Grade ISO 32
+40 to +105 Degrees F - Grade ISO 15
Below + 70 Degrees F - Grade ISO 10 or MIL-H-5606

See TABLES 11-1, 11-2 & 11-3, on page 13, for recommended brands.

1. Lower the Platform to ground level and make sure Platform is unfolded.
2. Remove the Filler Cap (FIG. 10-1).

NOTE: If the Hydraulic Fluid in the Reservoir is contaminated, do the **CHANGING HYDRAULIC FLUID** procedure in this section.

3. Check the Hydraulic Fluid level in the Pump Reservoir (FIG. 10-1). If fluid is below **FILL LEVEL** shown on Decal on the Pump Reservoir (FIG. 10-1), add fluid to the **FILL LEVEL**.
4. Reinstall the Filler Cap (FIG. 10-1).

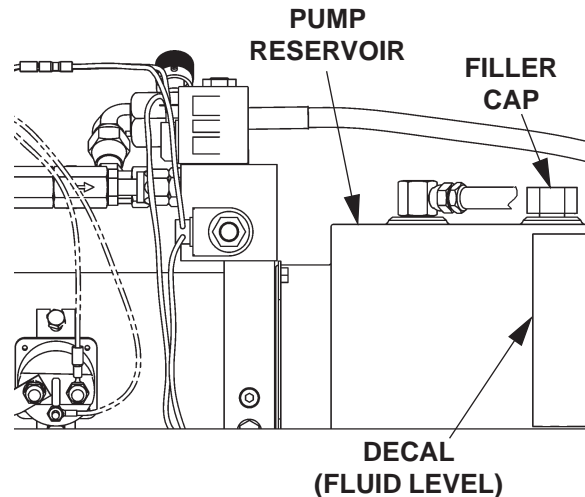

**CHECKING HYDRAULIC
FLUID LEVEL
FIG. 10-1**

ISO 32 HYDRAULIC OIL	
RECOMMENDED BRANDS	PART NUMBER
AMSOIL	AWH-05
CHEVRON	HIPERSYN 32
KENDALL	GOLDEN MV
SHELL	TELLUS T-32
EXXON	UNIVIS N-32
MOBIL	DTE-13M, DTE-24, HY- DRAULIC OIL-13

TABLE 11-1

ISO 15 HYDRAULIC OIL	
RECOMMENDED BRANDS	PART NUMBER
AMSOIL	AWF-05
CHEVRON	FLUID A, AW-MV-15
KENDALL	GLACIAL BLU
SHELL	TELLUS T-15
EXXON	UNIVIS HVI-13
MOBIL	DTE-11M
ROSEMEAD	THS FLUID 17111

TABLE 11-2

ISO-10 OR MIL-H-5606 HYDRAULIC FLUID	
RECOMMENDED BRANDS	PART NUMBER
AMSOIL	N/A
CHEVRON	FLUID A, FLUID G
KENDALL	GLACIAL BLU
SHELL	AEROSHELL FLUID-41
EXXON	UNIVIS HVI-13
MOBIL	AERO HFA
ROSEMEAD	THS FLUID 17111

TABLE 11-3

PERIODIC MAINTENANCE CHANGING HYDRAULIC FLUID

CAUTION

Keep dirt, water and other contaminants from entering the hydraulic system. Before opening the hydraulic fluid reservoir filler cap, drain plug and hydraulic lines, clean up contaminants that can get in the openings. Also, protect the openings from accidental contamination.

NOTE: Use correct grade of hydraulic fluid for your location.

- | | |
|------------------------------|-------------------------------------|
| +70 to +140 Degrees F | - Grade ISO 32 |
| +40 to +105 Degrees F | - Grade ISO 15 |
| Below + 70 Degrees F | - Grade ISO 10 or MIL-H-5606 |

See **TABLES 11-1, 11-2 & 11-3** on previous page for recommended brands.

NOTE: To prevent spills, drain used hydraulic fluid through a funnel into waste fluid container.

1. Place empty 5 Gallon Bucket under Drain Plug.
2. Open and raise Platform to vehicle bed height. Remove the Drain Plug (**FIG. 12-1**). Drain hydraulic fluid.
3. Disconnect the White Wire (**FIG. 12-2**) from Motor Solenoid. Lower the Platform while draining the remaining hydraulic fluid from system. Re-install Drain Plug. Reconnect the White Wire to Motor Solenoid.
4. Remove Filler Cap (**FIG. 12-2**) and refill reservoir to the level shown on decal.

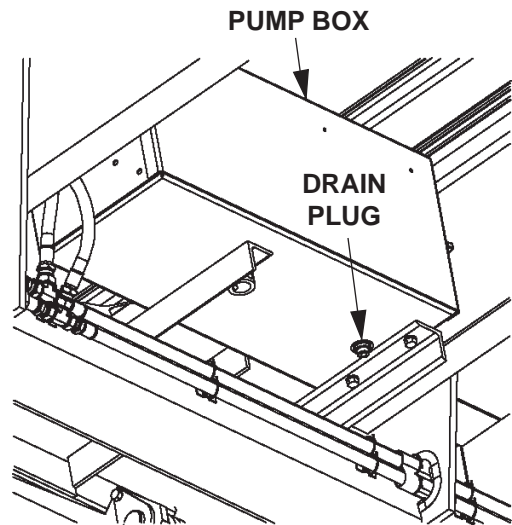

FIG. 12-1

5. Raise Platform to vehicle bed height. Check hydraulic fluid again and, if needed, add more hydraulic fluid (**FIG. 12-2**).
6. Reinstall Filler Cap (**FIG. 12-2**).

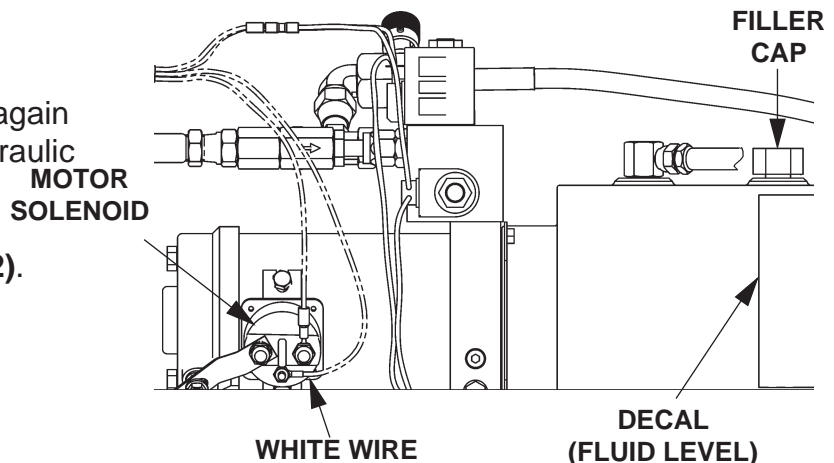

FIG. 12-2

PERIODIC MAINTENANCE

REPLACING PLATFORM TORSION SPRING

NOTE: The following procedure shows how to replace Torsion Spring on RH side of Platform. Use this procedure for replacing Torsion Spring on the LH Side.

1. Manually fold Flipover onto Platform.
2. Raise Platform to a convenient work height to gain access and release tension on the Torsion Spring.

⚠ CAUTION

To prevent injury and equipment damage, make sure there is no tension on torsion spring before removing hinge pin.

3. Unbolt Hinge Pin from Hinge Bracket (**FIG. 13-1**). Remove bolt and lock nut. Drive the Hinge Pin inboard toward the Shackle with a hammer and pin punch, just enough to free the torsion spring (**FIG. 13-1**). Remove spring from Shackle.

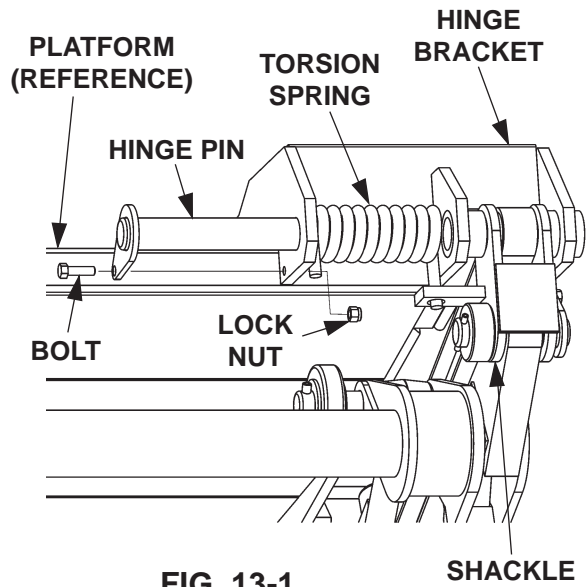

FIG. 13-1

4. Install the Torsion Spring as shown in **FIG. 13-2**. Make sure the long leg of the spring is inserted in the bracket located on Shackle (**FIG. 13-2**). Make sure the short end of the spring is visible and resting against the edge of the Hinge Bracket (**FIG. 13-2**).

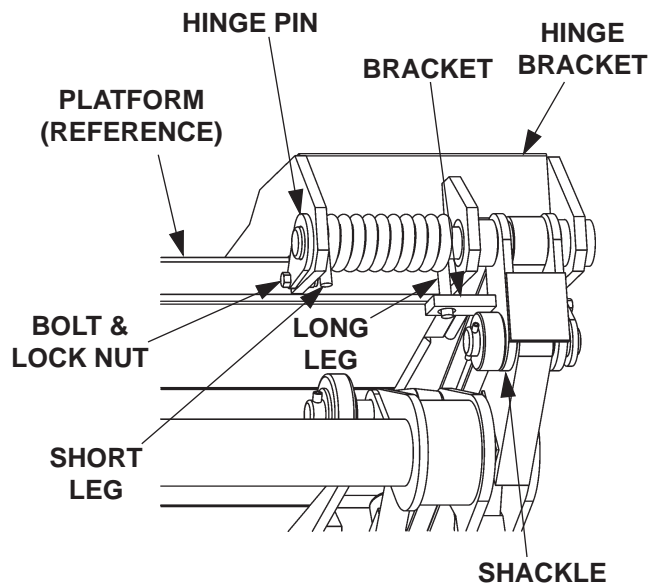

FIG. 13-2

5. Drive the Hinge Pin into correct position (**FIG. 5**) through the Hinge Bracket with a hammer and pin punch. Line up the bolt hole in the Hinge Pin with the hole in the Hinge Bracket. Bolt the Hinge Pin to Hinge Bracket with bolt and lock nut (**FIG. 5**).

6. Operate the Liftgate to make sure it operates correctly.

PLATFORM ADJUSTMENT

NOTE: Before doing the following procedure, make sure vehicle is parked on level ground.

1. With the Platform and Flipover unfolded, **RAISE** Platform to bed level (**FIG. 14-1**). Measure how much the outboard edge of Platform rises above bed level (**FIG. 14-1**). The outboard edge must be level or a maximum of 2" above bed level (**FIG. 14-1**). If indication is correct, Liftgate is installed correctly and no adjustment is needed. If the outboard edge is below bed level, do instructions **2,3, and 6**. If outboard edge is higher than 2", do instructions **4 through 6**.

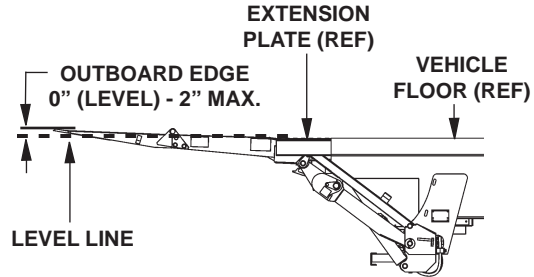

PLATFORM EDGE AT OR ABOVE BED LEVEL
FIG. 14-1

2. Compare measurement "A" (**FIG. 14-2**), with the distances and shims in **TABLE 14-1**. For example: If Measurement "A" (**FIG. 14-2**) is 1" below level and you want to raise outboard edge of Platform 2" above level, use 1/8" shim to raise 2" (**TABLE 14-1**).

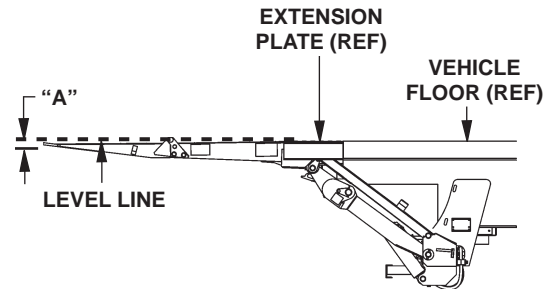

PLATFORM EDGE BELOW BED LEVEL
FIG. 14-2

RAISE PLATFORM EDGE (OUTBOARD) THIS DISTANCE ("A")	REQUIRED SHIM THICKNESS	WELD SIZE "W"
1"	1/16"	1/16"
2"	1/8"	1/8"
3"	3/16"	3/16"
4"	1/4"	1/4"

TABLE 14-1

3. Weld shims (Parts Bag item) on both Platform Stops (**FIG. 14-3**) to raise outboard edge of Platform to correct position.

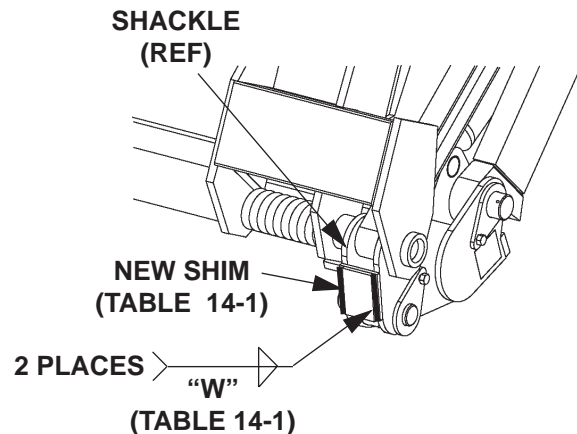

WELDING SHIMS (CURBSIDE SHOWN)
FIG. 14-3

MAXON

11921 Slauson Ave. Santa Fe Springs, CA. 90670 (800) 227-4116 FAX (888) 771-7713

4. Compare measurement “B” (FIG. 15-1), with distances and grinding depths in TABLE 15-1. For example: if Measurement “B” (FIG. 15-1) is 3” above bed level and you want to lower the outboard edge of Platform to 1” above bed level, grind 1/8” from each Platform Stop (TABLE 15-1).

LOWER PLATFORM EDGE (OUTBOARD) THIS DISTANCE(“B”)	GRIND METAL FROM PLATFORM STOP
1”	1/16”
2”	1/8”
3”	3/16”
4”	1/4”

TABLE 15-1

5. Grind metal from Platform Stops (FIG. 15-2) to lower outboard edge of Platform to correct position.

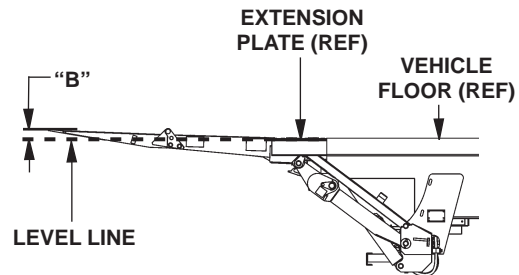

PLATFORM EDGE ABOVE BED LEVEL
FIG. 15-1

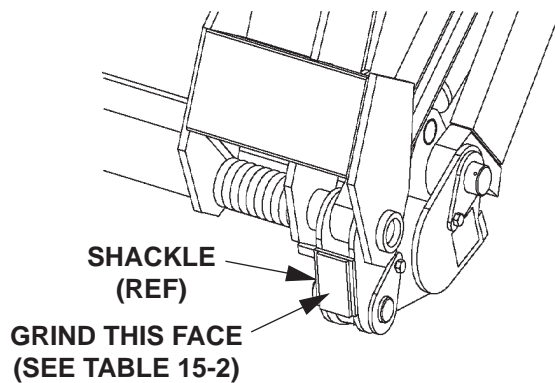

GRINDING PLATFORM STOPS
(CURBSIDE SHOWN)
FIG. 15-2

6. LOWER the Platform, then RAISE it to bed level. The outboard edge of Platform should be level or up to 2” maximum above bed level (FIG. 15-3).

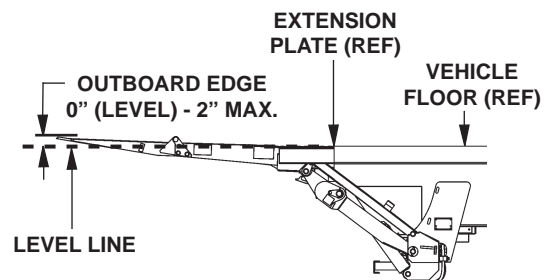

PLATFORM EDGE ABOVE BED LEVEL
FIG. 15-3

PARTS BREAKDOWN MAIN ASSEMBLY (ALUMINUM PLATFORM)

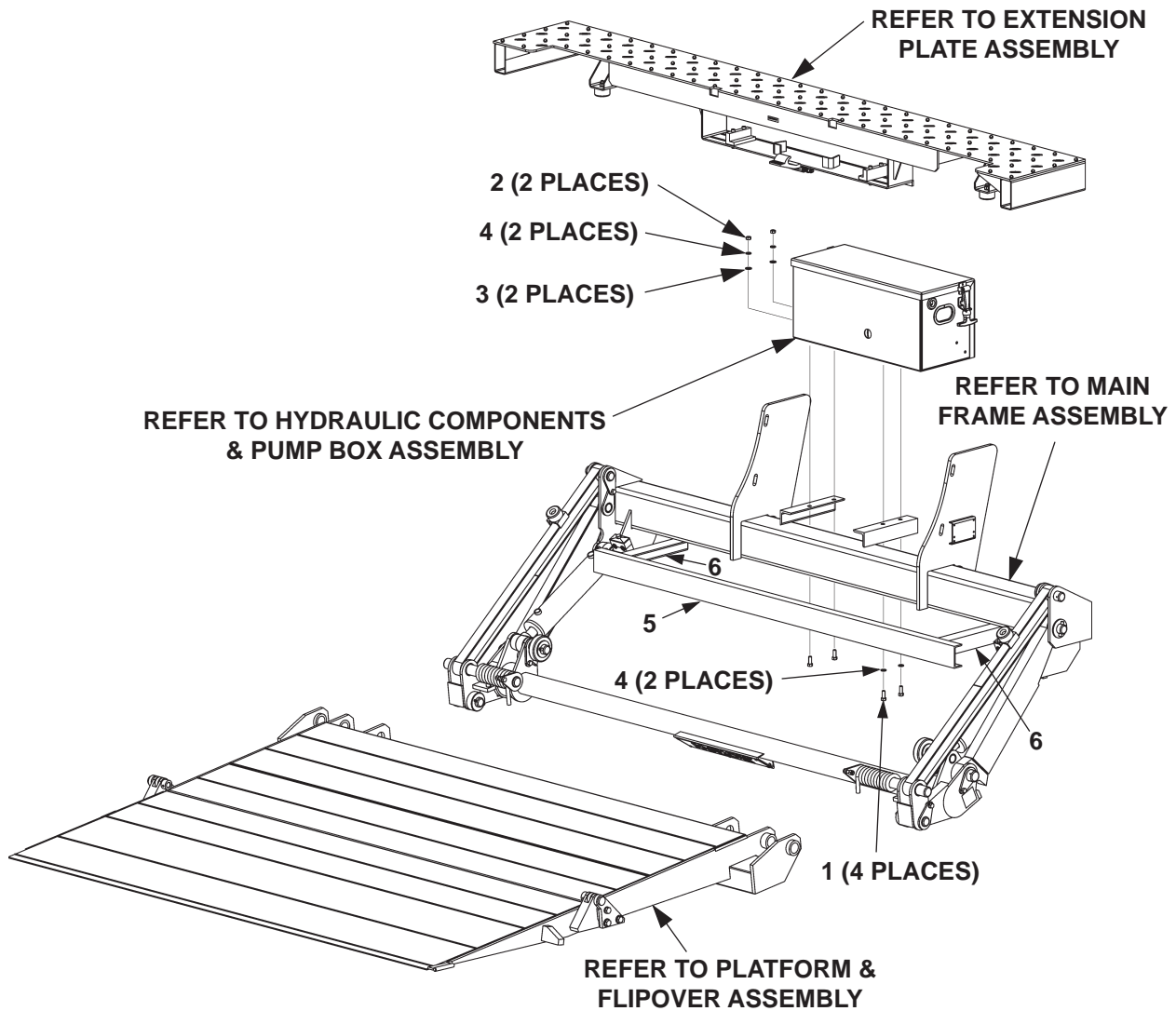

ITEM	QTY.	PART NO.	DESCRIPTION
1	4	900014-4	BOLT, HEX HEAD 3/8-16 X 1"
2	2	901011-5	NUT, HEX HEAD 3/8-16 UNC-2B
3	2	902001-2	WASHER, FLAT 3/8" X 1/16"
4	4	902011-4	WASHER, LOCK 3/8" X 15/16"
5	1	265743	CHANNEL, 3" X 4" X 67" LG. (ICC BUMPER)
6	2	264209	ANGLE, 2" X 2" X 1/4" X 14" LG. (ICC BUMPER)

MAXON®

11921 Slauson Ave. Santa Fe Springs, CA. 90670 (800) 227-4116 FAX (888) 771-7713

EXTENSION PLATE ASSEMBLY

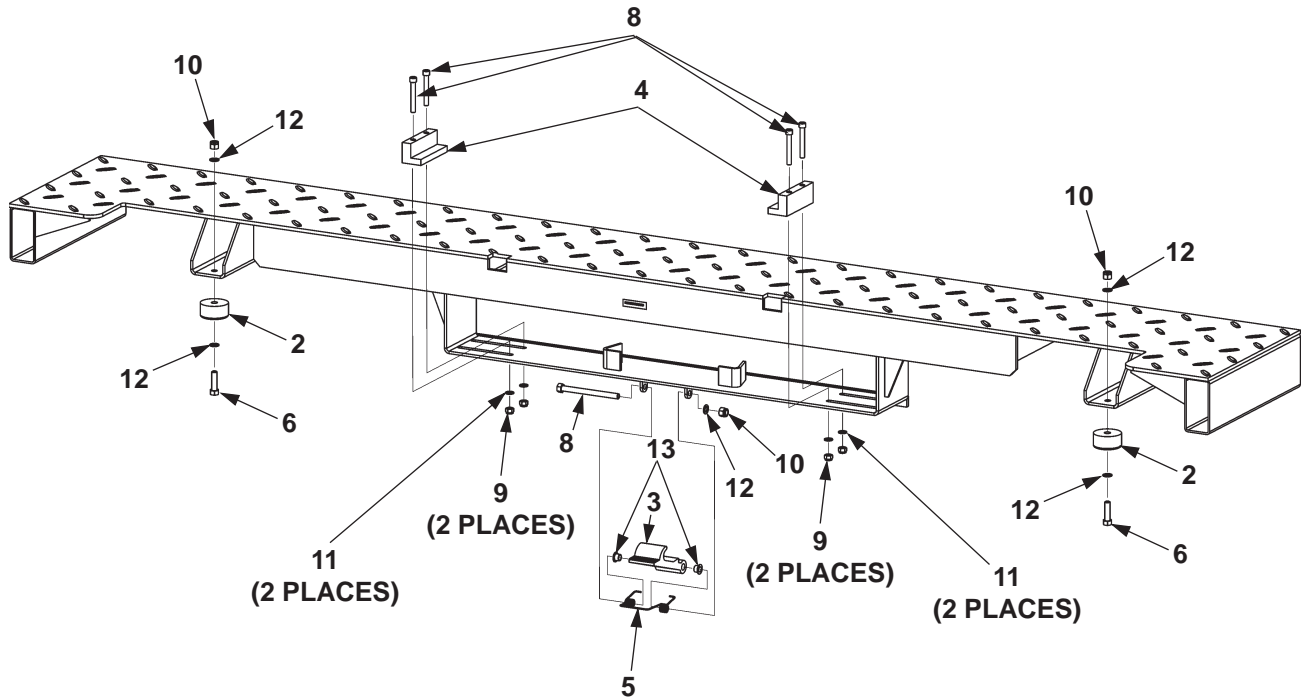

ITEM	QTY	PART NO.	DESCRIPTION
1	1	267707-01	EXTENSION PLATE ASSEMBLY
1A	1	267705-01	EXTENSION PLATE WELDMENT, 96"
2	2	267708-01	NYLON BUMPER
3	1	267715-01	WALKRAMP LATCH
4	2	267729-01	WALKRAMP PAD
5	1	267736-01	DOUBLE TORSION SPRING
6	2	900014-1	CAP SCREW, 3/8"-16 X 1-3/8" LG.
7	1	900014-15	CAP SCREW, 3/8"-16 X 4-1/2" LG.
8	4	900726-11	SOCKET SCREW, 5/16" X 2-1/4"
9	4	901001	LOCK NUT, 5/16"-18
10	3	901002	LOCK NUT, 3/8"-16
11	4	902000-8	FLAT WASHER, 3/16"
12	5	902000-10	FLAT WASHER, 3/8"
13	2	908094-01	FLANGE BEARING, 3/8" DIA X 3/8" LG.

MAIN FRAME ASSEMBLY

MAXON®

11921 Slauson Ave. Santa Fe Springs, CA. 90670 (800) 227-4116 FAX (888) 771-7713

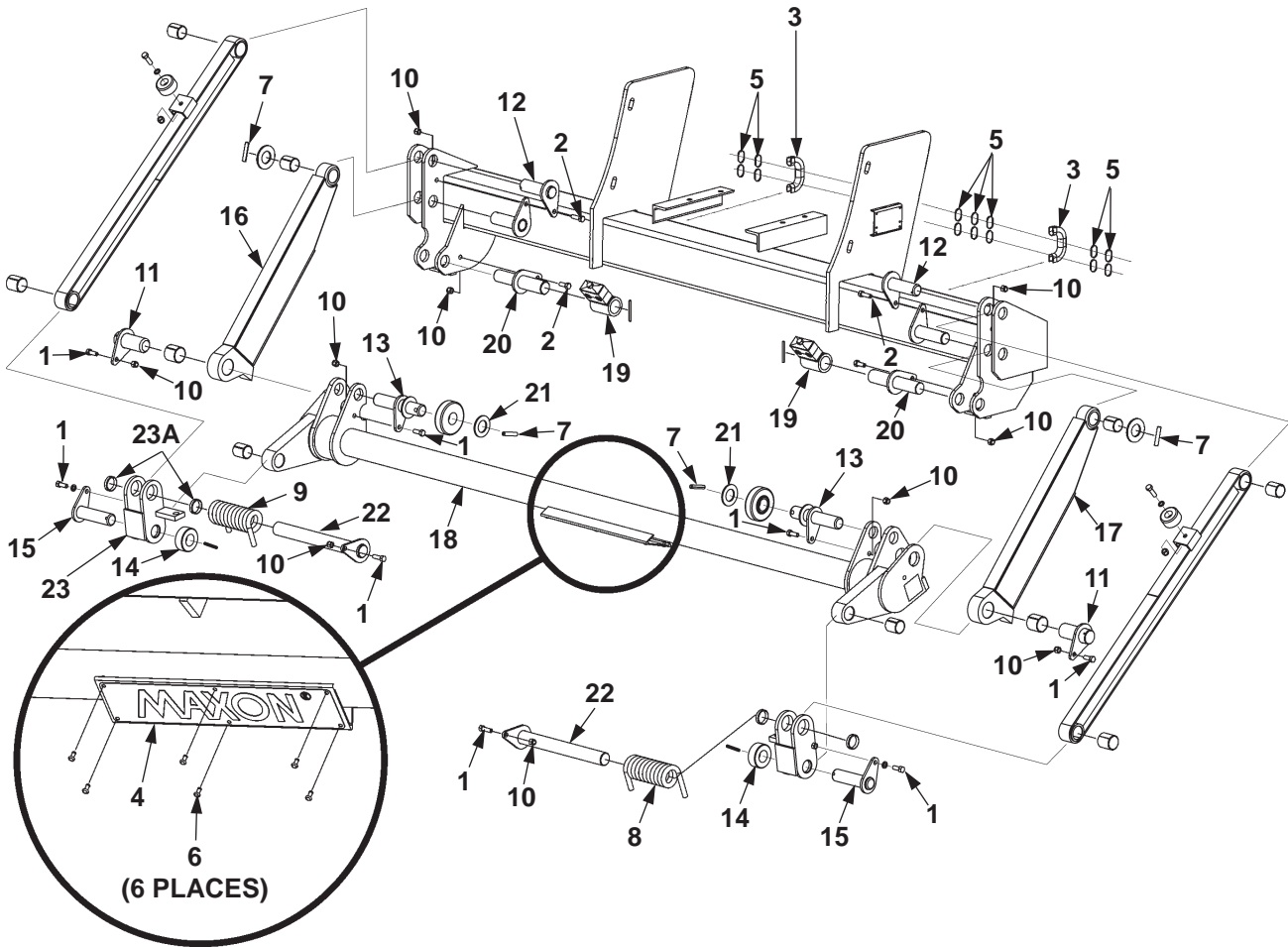

ITEM	QTY.	PART NO.	DESCRIPTION
1	8	030034	BOLT, 3/8"-24 X 1" LG.
2	4	030035	BOLT, 3/8"-24 X 1-1/4" LG.
3	2	040103-5	LOOM, 1/2" X 5" LG.
4	1	050175	MAXON PLATE
5	14	205780	PLASTIC TIE, 7" LG.
6	6	207644	RIVET, 3/16" X .40"
7	4	221416	ROLL PIN, 3/8" X 2" LG.
8	1	226363-01	TORSION SPRING, RH, 1/2" X 5-3/4"
9	1	226363-02	TORSION SPRING, LH, 1/2" X 5-3/4"
10	10	226941	LOCK NUT, 3/8"-24
11	2	229657	PIN WELDMENT
12	2	250310	PIN WELDMENT
13	2	253045	PIN WELDMENT
14	2	253047	ROLLER, 1"
15	2	262280	PIN WELDMENT
16	1	262322-01	LIFT ARM WELDMENT, LH
17	1	262322-02	LIFT ARM WELDMENT, RH
18	1	262396-01	LIFT FRAME WELDMENT, NO ROLLER
19	2	262437	BUSHING WELDMENT HOSE CLAMP
20	2	262440	PIN WELDMENT
21	2	264272	FLAT WASHER, 2-1/4"
22	2	265807-01	PIN WELDMENT, 1-3/8" X 13-1/8" LG.
23	1	265815-01	SHACKLE ASSEMBLY, LH
23A	2	905112-06	SELF LUBE BEARING, 1-3/8" X 3/8"

MAIN FRAME ASSEMBLY - Continued

MAXON[®]

11921 Slauson Ave. Santa Fe Springs, CA. 90670 (800) 227-4116 FAX (888) 771-7713

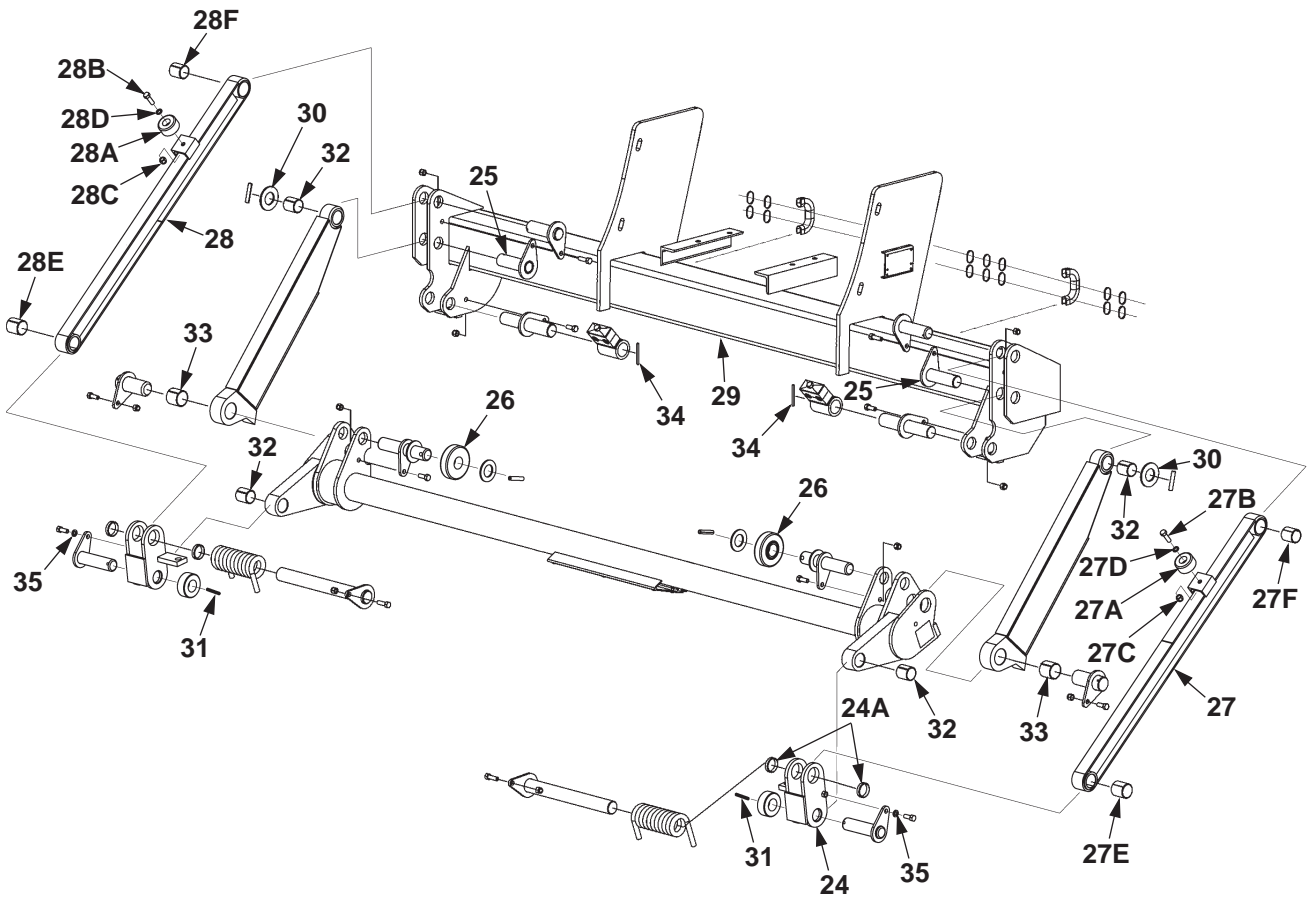

ITEM	QTY.	PART NO.	DESCRIPTION
24	1	265815-02	SHACKLE ASSEMBLY, RH
24A	2	905112-06	SELF LUBE BEARING, 1-3/8" X 3/8"
25	2	266035-01	PIN WELDMENT
26	2	267704-01	ROLLER
27	1	267712-02	PARALLEL ARM, RH
27A	1	267708-01	NYLON BUMPER
27B	1	900014-5	CAP SCREW, 3/8" -16 X 1-1/4" LG.
27C	1	901002	LOCK NUT, 3/8"-16
27D	1	902000-10	FLAT WASHER, 3/8"
27E	1	905114-04	SELF LUBE BEARING, 1-1/4" X 1-1/2" LG.
27F	1	905112-04	SELF LUBE BEARING, 1-3/8" X 1-1/2" LG.
28	1	267712-01	PARALLEL ARM, LH
28A	1	267708-01	NYLON BUMPER
28B	1	900014-5	CAP SCREW, 3/8" -16 X 1-1/4" LG.
28C	1	901002	LOCK NUT, 3/8"-16
28D	1	902000-10	FLAT WASHER, 3/8"
28E	1	905114-04	SELF LUBE BEARING, 1-1/4" X 1-1/2" LG.
28F	1	905112-04	SELF LUBE BEARING, 1-3/8" X 1-1/2" LG.
29	1	281561-01	MAIN FRAME
30	2	902013-20	FLAT WASHER, 1-1/4"
31	2	905033-5	ROLL PIN, 1/4" X 2"LG
32	4	905114-04	SELF LUBE BEARING, 1-1/4" X 1-1/2" LG.
33	2	905115-02	SELF LUBE BEARING, 1-1/2" X 1-1/2" LG.
34	2	907026	ROLL PIN, 3/16" X 2-1/4" LG.
35	2	902011-4	LOCK WASHER, 3/8"

PLATFORM & FLIPOVER ASSEMBLY (ALUMINUM)

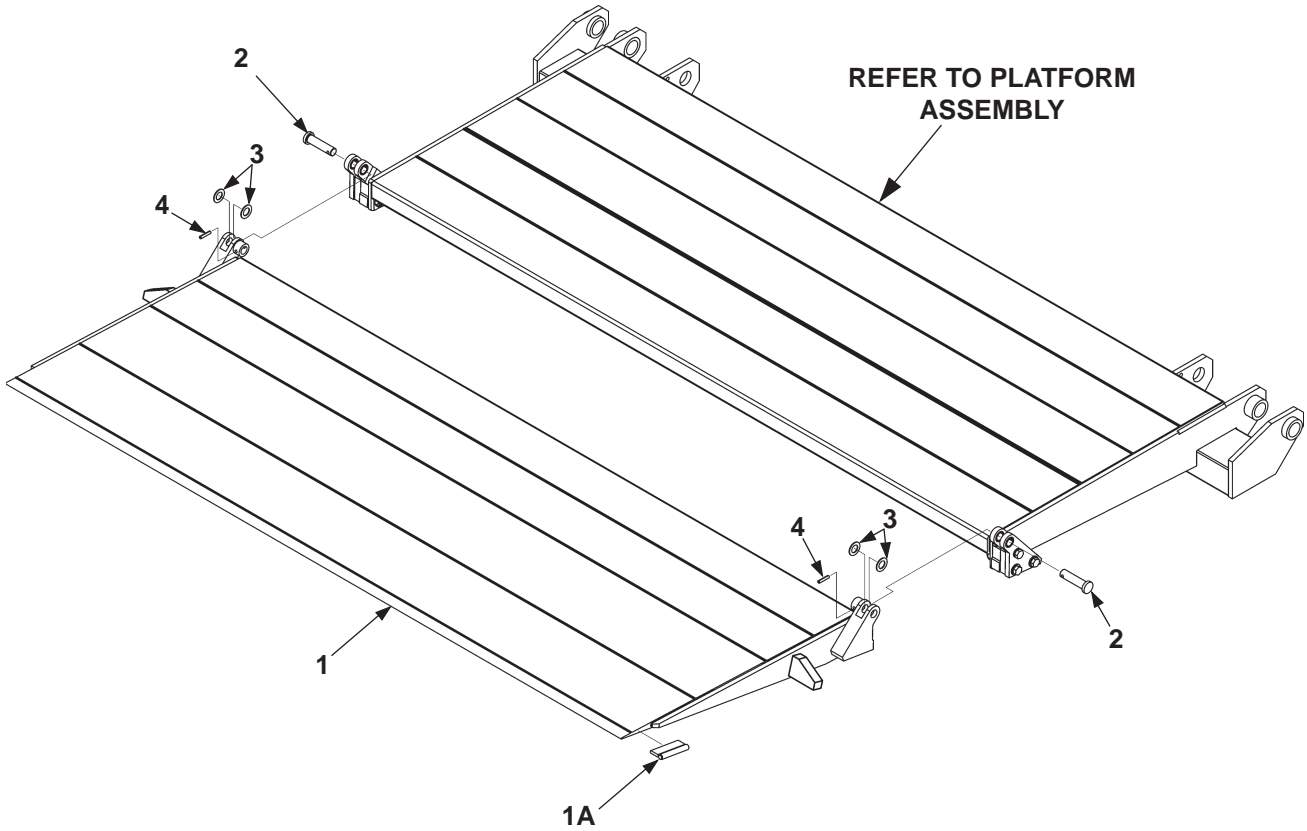

ITEM	QTY.	PART NO.	DESCRIPTION
1	1	267719-01	FLIPOVER WELDMENT, 30" (WEDGE)
1A	1	265819-01	HANDLE WELDMENT
2	2	263602	HINGE PIN WELDMENT
3	4	902020-1	FLAT WASHER, 1-5/16"
4	2	905033-2	ROLL PIN, 1/4" X 1-1/4"

MAXON®

11921 Slauson Ave. Santa Fe Springs, CA. 90670 (800) 227-4116 FAX (888) 771-7713

THIS PAGE INTENTIONALLY LEFT BLANK

PLATFORM ASSEMBLY (ALUMINUM)

MAXON[®]

11921 Slauson Ave. Santa Fe Springs, CA. 90670 (800) 227-4116 FAX (888) 771-7713

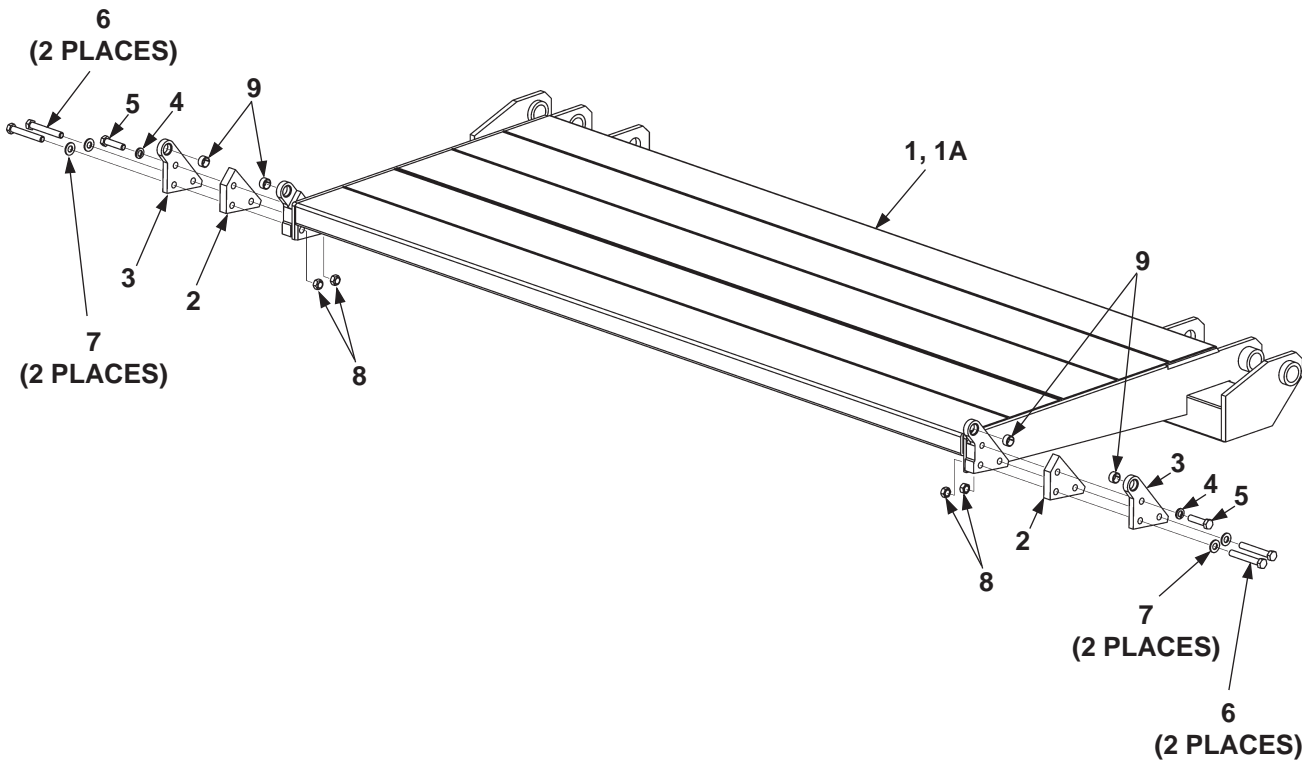

ITEM	QTY.	PART NO.	DESCRIPTION
1	1	281510-01	PLATFORM ASSEMBLY, 30"
1A	1	281508-01	PLATFORM WELDMENT, 30"
2	2	263608	HINGE BRACKET, INSIDE
3	2	263609	HINGE BRACKET, OUTSIDE
4	2	902011-6	LOCK WASHER, 1/2"
5	2	900033-9	CAP SCREW, 1/2"-20 X 2" LG.
6	4	900035-10	CAP SCREW, 1/2"-13 X 3-1/2" LG.
7	4	902013-13	FLAT WASHER, 1/2"
8	2	040066	LOCK NUT, 1/2"-13
9	4	260917-04	SELF LUBE BEARING, 1/2" LG.

MAXON[®] 11921 Slauson Ave. Santa Fe Springs, CA. 90670 (800) 227-4116 FAX (888) 771-7713

DOCK BUMPER

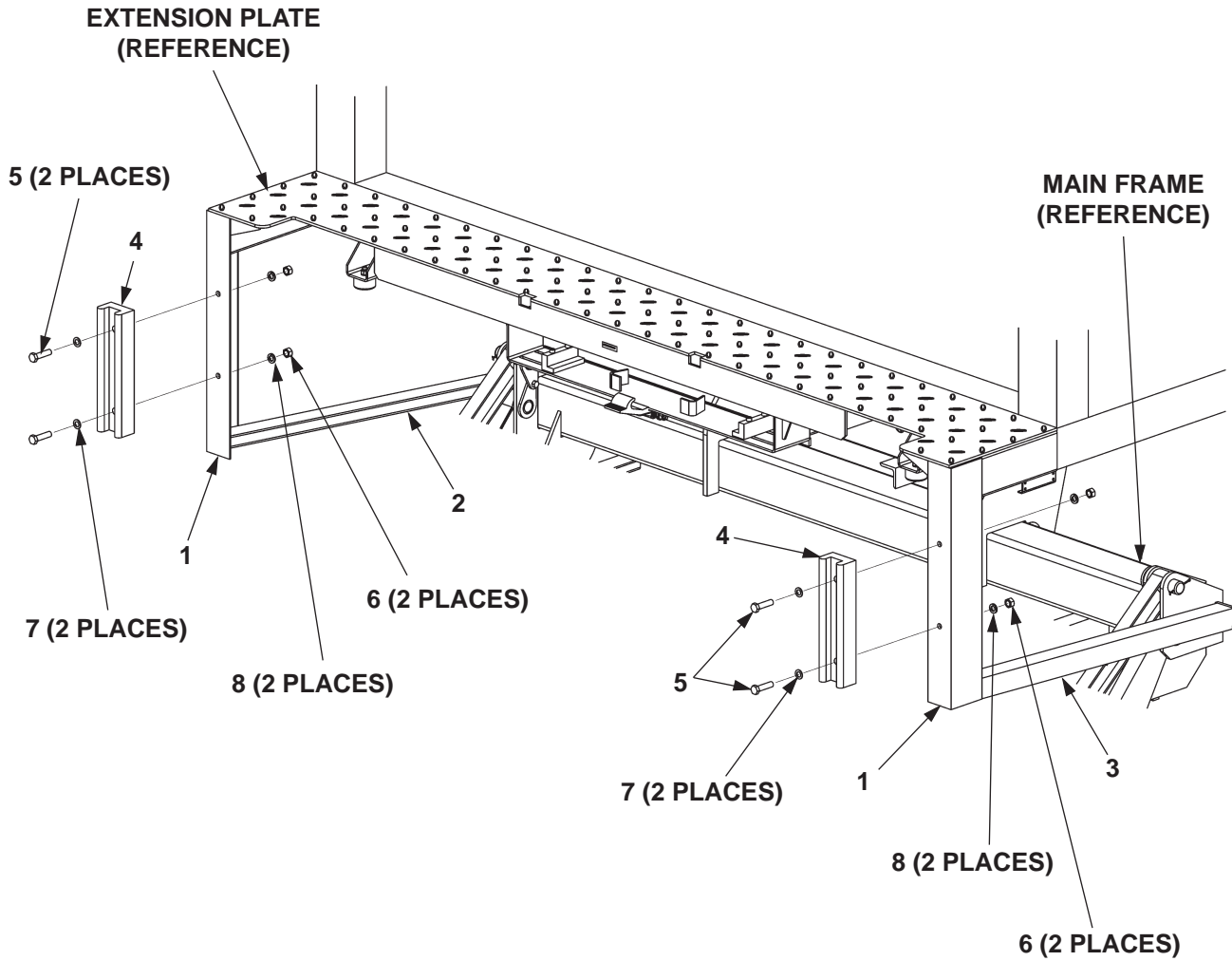

ITEM	QTY.	PART NO.	DESCRIPTION
1	2	226856	DOCK BUMPER ANGLE X 23-1/2"
2	1	266019-03	BRACE ANGLE L/H
3	1	266019-04	BRACE ANGLE R/H
4	2	222988	BUMPER
5	4	900033-5	CAP SCREW, 1/2"-20 X 2" LG.
6	4	901011-10	NUT, 1/2"
7	4	902000-14	FLAT WASHER, 1/2"
8	4	902011-6	LOCK WASHER, 1/2"

MAXON®

11921 Slauson Ave. Santa Fe Springs, CA. 90670 (800) 227-4116 FAX (888) 771-7713

THIS PAGE INTENTIONALLY LEFT BLANK

HYDRAULIC COMPONENTS - POWER DOWN

MAXON[®]

11921 Slauson Ave. Santa Fe Springs, CA. 90670 (800) 227-4116 FAX (888) 771-7713

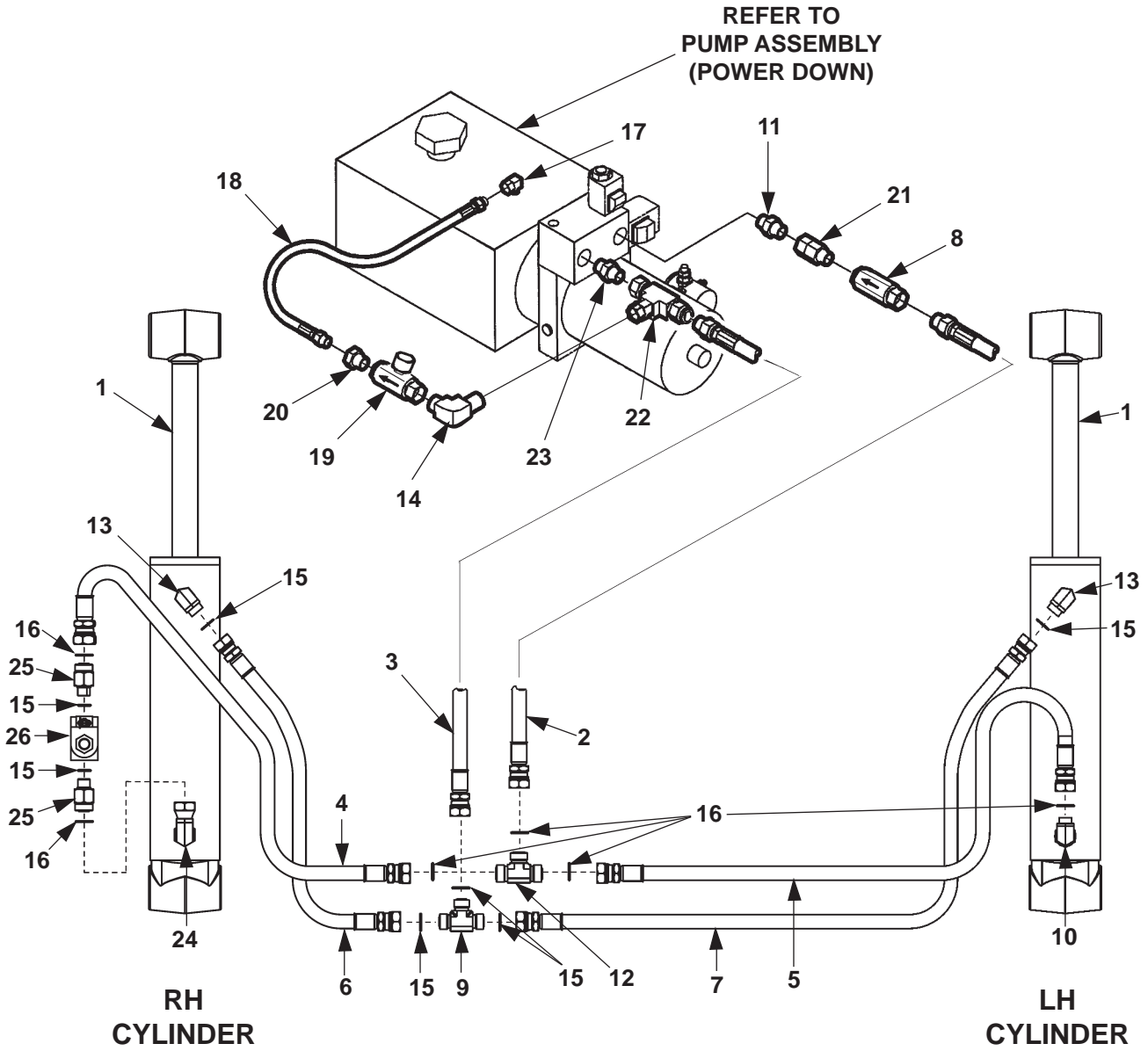

NOTE: Replacement Face Seal Fittings come with required O-Rings.

ITEM	QTY.	PART NO.	DESCRIPTION
1	2	266037-01	CYLINDER, 2-3/4" x 10"
2	1	265846-01	HOSE ASSY, 3/8"HP SAE#8F,#6M, 21" LG.
3	1	265863-01	HOSE ASSY, 3/8"HP SAE#6- #8 F-F, 26" LG.
4	1	265888-01	HOSE ASSY, 3/8"HP SAE#8 F-F, 57" LG.
5	1	265888-02	HOSE ASSY, 3/8"HP SAE#8 F-F, 83" LG.
6	1	265889-01	HOSE ASSY, 3/8"HP SAE#6 F-F, 55" LG.
7	1	265889-02	HOSE ASSY, 3/8"HP SAE#6 F-F, 77" LG.
8	1	906709-01	VALVE,FLOW REGULATOR #6 SAE, 4 GPM
9	1	905150	TEE, UNION, 3/8" F/S MALE,6-JLO
10	1	906704-01	ELBOW, STRAIGHT THR. #8 F/S O-RING M-M
11	1	906771-01	CONNECTOR, STRAIGHT, #6 - #8, M-M, O-RING F/S
12	1	906706-01	TEE, UNION SAE#8 F/S M-M
13	2	906707-01	ELBOW, STRAIGHT THD. #6F/S O-RING M-M
14	1	906770-01	ELBOW, MALE PIPE, #8 O-RING FS-NPTF
15	6	906712-02	O-RING #6 (3/8" FACE SEAL TUBE-END)
16	5	906712-03	O-RING #8 (1/2" FACE SEAL TUBE-END)
17	1	050207	FITTING, SWIVEL ELBOW
18	1	226948-09	HOSE ASSY, 1/4" HP X 18-1/2" LG., M-M 1/4" NPTF
19	1	260490	NEEDLE VALVE, F-F 3/8" NPTF
20	1	800183	BUSHING, 3/8"-1/4"
21	1	906751-01	FITTING, STRAIGHT O-RING, SAE#6 M (WITH SWIVEL)
22	1	906769-01	BRANCH TEE, SWIVEL NUT, SAE#8 M-M/F
23	1	906772-01	CONNECTOR, STRAIGHT SWIVEL, #8, M-F, O-RING F/S
24	1	906763-01	CONNECTOR, ELBOW, #8 O-RING M X #8 FS F
25	2	906762-01	CONNECTOR, #8 FS X #6 O-RING, M-M
26	1	281308-03	LOCK VALVE & HARNESS ASSEMBLY

POWER UNIT - POWER DOWN

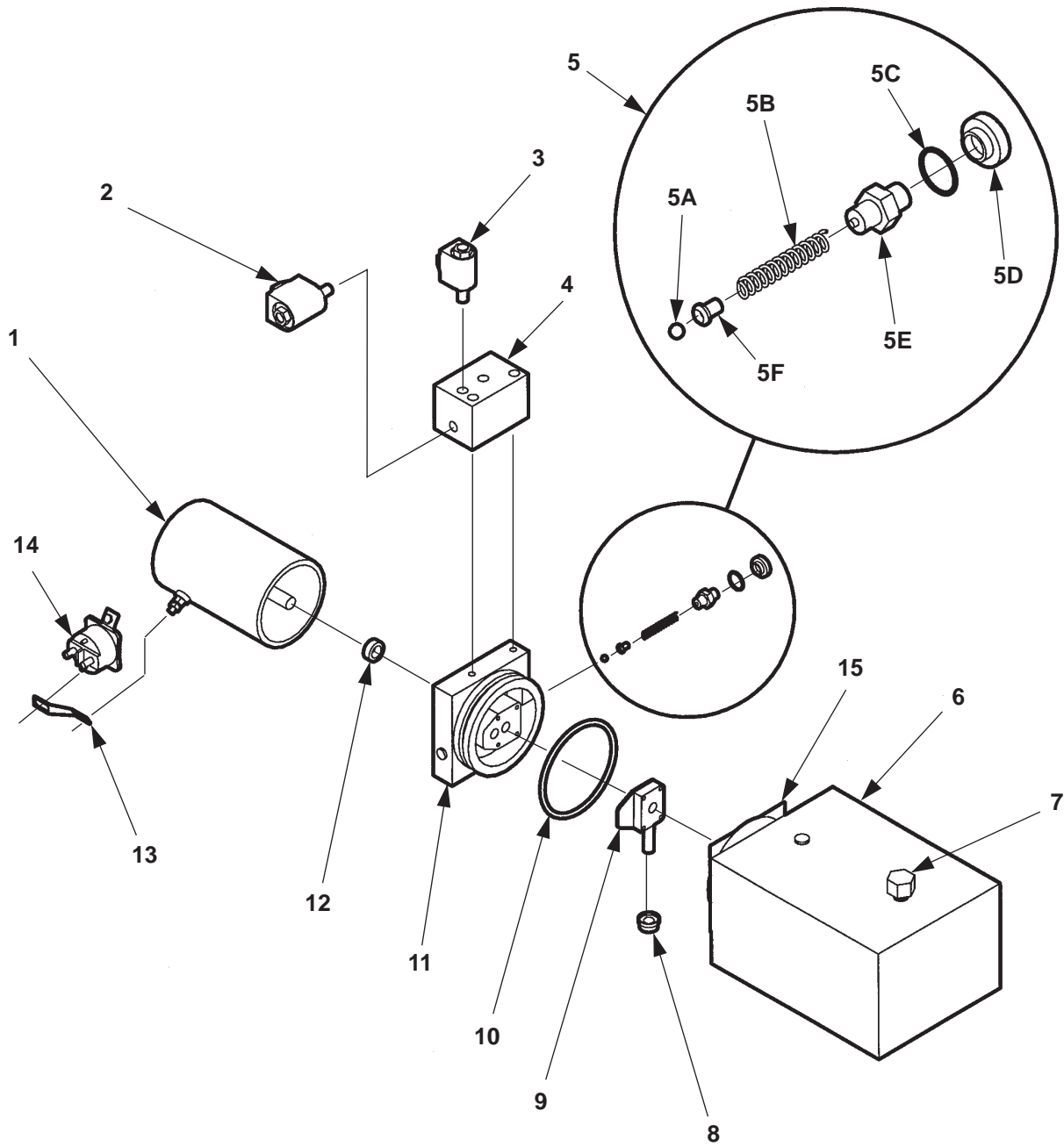

MAXON®

11921 Slauson Ave. Santa Fe Springs, CA. 90670 (800) 227-4116 FAX (888) 771-7713

ITEM	QTY.	PART NO.	DESCRIPTION
REF	1	262256	POWER UNIT
1	1	250093	MOTOR, HEAVY DUTY, 12 VDC
2	1	260276	VALVE, 4-WAY SOLENOID
2A	1	226595	O-RING KIT, 4-WAY VALVE (NOT SHOWN)
3	1	253353	VALVE, 2-WAY SOLENOID
3A	1	226594	O-RING KIT, 2-WAY VALVE (NOT SHOWN)
4	1	260275	MANIFOLD BLOCK
5	1	260229	RELIEF VALVE KIT
5A	1	260230	STEEL BALL
5B	1	260231	SPRING
5C	1	260235	O-RING
5D	1	260234	VALVE CUP
5E	1	260232	ADJUSTING SCREW
5F	1	260233	SPRING GUIDE
6	1	260263	RESERVOIR, 2.5 GAL.
7	1	229193	FILLER/BREATHER CAP
8	1	260250	FILTER
9	1	290003	3-PIECE GEAR PUMP
10	1	251884	O-RING
11	1	260252	PORT PLATE ASSY, 5"
12	1	260261	OIL SEAL
13	1	262966	BUS BAR
14	1	262939	STARTER SWITCH, 12 VDC, 3 TERMINAL
15	4	229202	CAP SCREW (NOT SHOWN)

MAXON[®] 11921 Slauson Ave. Santa Fe Springs, CA. 90670 (800) 227-4116 FAX (888) 771-7713

PUMP BOX ASSEMBLY - POWER DOWN

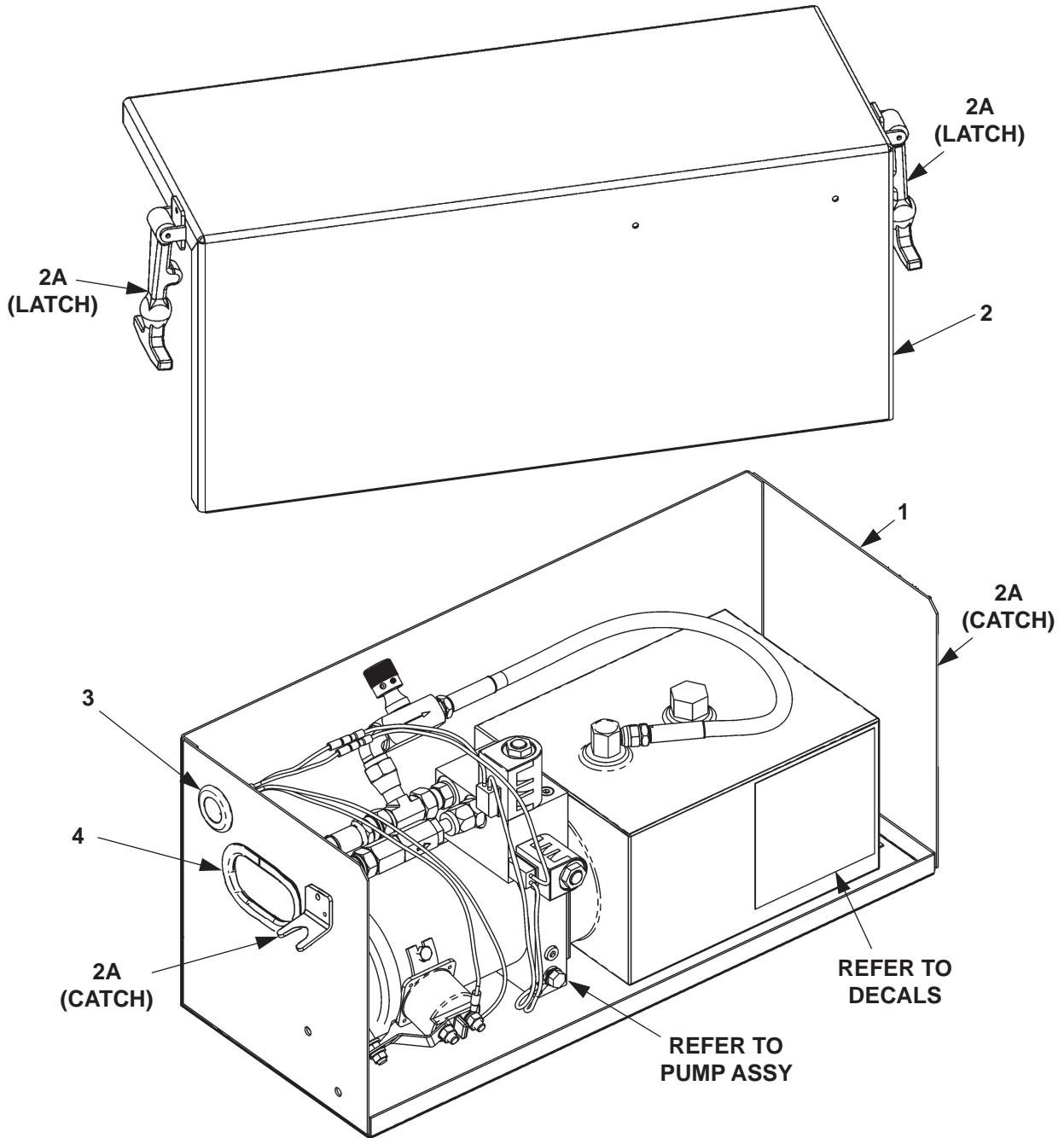

ITEM	QTY.	PART NO.	DESCRIPTION
REF	1	260157	PUMP BOX ASSEMBLY
1	1	260156	PUMP BOX WELDMENT
2	1	229383	PUMP BOX COVER
2A	2	215139	CATCH & FASTENER
3	1	251097	RUBBER GROMMET, 7/8" I.D., 1-5/8" O.D.
4	1	093209-10	EDGE TRIM, 8-1/2" LG.

MAXON®

11921 Slauson Ave. Santa Fe Springs, CA. 90670 (800) 227-4116 FAX (888) 771-7713

CONTROL SWITCH AND POWER CABLE

NOTE: Use Switch to **RAISE** and **LOWER** Liftgate to make sure Switch operates as shown on the decal.

NOTE: MAXON recommends using dielectric grease on all electrical connections.

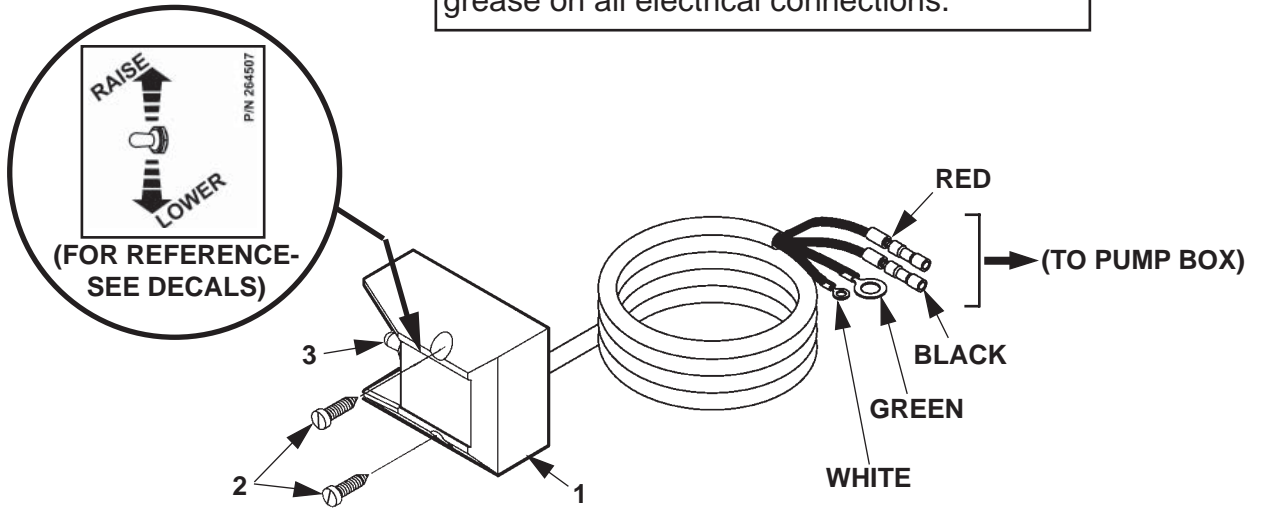

FIG. 33-1

ITEM	QTY.	PART NO.	DESCRIPTION
1	1	264951-01	SWITCH & CABLE ASSEMBLY
2	2	900057-5	SCREW, SELF-TAPPING #10-24 X 1" LG.
3	1	905206	SWITCH BOOT SEAL
4	1	264422	CABLE ASSEMBLY, 200 AMPS, 38' LG.
5	1	264687	KIT, MEGAFUSE (200 AMP FUSE & HEATSHRINK TUBING)

TABLE 33-1

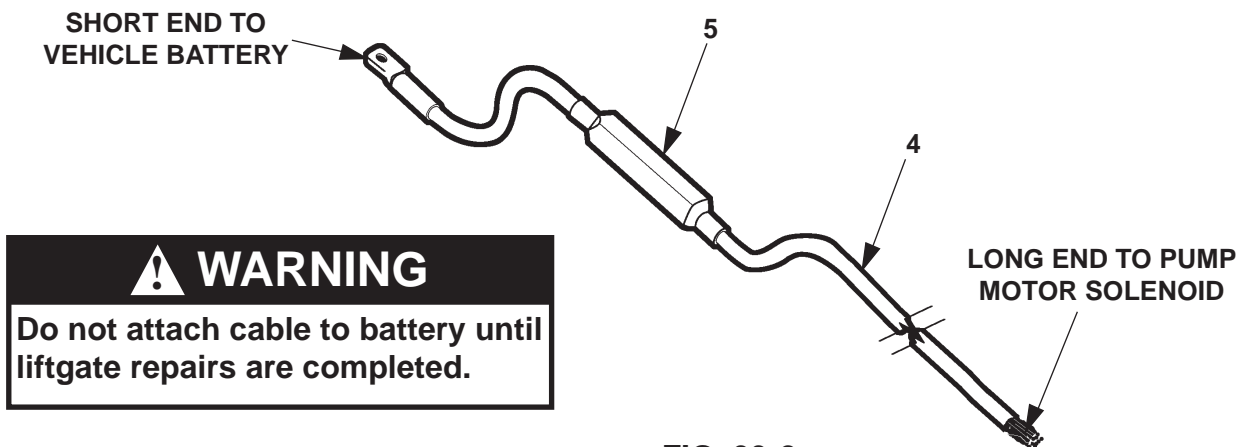
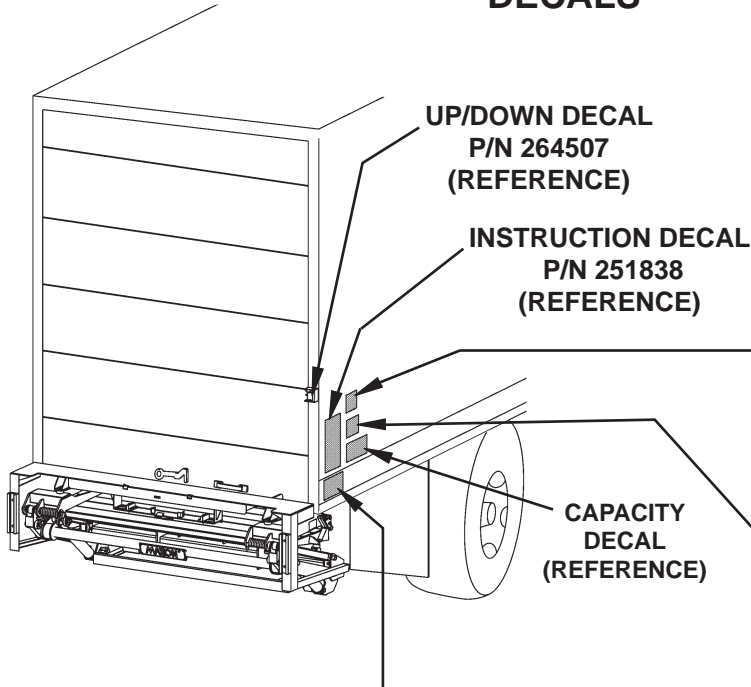

FIG. 33-2

DECALS



**WALK RAMP
WARNING DECAL
P/N 265441-01**

WARNING

READ THIS INFORMATION CAREFULLY

- Improper operation of this Lift can result in serious personal injury. Do not operate unless you have been properly instructed and have read, and are familiar with the operating instructions. If you do not have a copy of the instructions, please obtain them from your employer, distributor, or lessor, before you attempt to operate Lift.
- Be certain that the vehicle is properly and securely braked before using the Lift.
- Always inspect this Lift for maintenance or damage before using it. If there are signs of improper maintenance, damage to vital parts, or slippery Platform surface, do not use the Lift until these problems have been corrected.
- Do not overload the Lift. The load limit is based on evenly distributed cargo over the entire Platform surface. If you are using a pallet jack, be sure it can be maneuvered safely. Do not operate a forklift on the Platform or travel with the platform in an open position at any time.
- Load should be placed in a stable position close to the edge of the Platform nearest the truck. The heaviest portion of the load should never be placed beyond the center of the Platform away from the truck.
- Never allow yourself, a helper, or bystander to stand in a position where a falling load could land on either of you. Also do not allow any part of yours or your helper's body to be placed under, within, or around any portion of the moving liftgate, or its mechanisms, or in a position that would trap them between the platform and the ground or truck when the liftgate is operated.
- If a helper is riding the Platform with you, make sure you are both doing so safely and that you are not in danger of coming in contact with any moving or potentially moving obstacles. USE GOOD COMMON SENSE. If load appears to be unsafe, do not lift or lower it.

For a free copy of other manuals that pertain to this model Liftgate, please visit our website at www.maxonlift.com or call Customer Service at (800) 227-4116.

MAXON LIFT CORP. PART NO. 264081

**WARNING DECAL
P/N 264081**

NOTICE

- 1 READ WALK RAMP WARNING DECAL BEFORE YOU SET UP WALK RAMP.
- 2 TO SET UP WALK RAMP & STOW WALK RAMP, REFER TO WALK RAMP MANUFACTURER'S INSTRUCTIONS.

DECAL, P/N 266013-02

**WALK RAMP
NOTICE DECAL
P/N 266013-02**

FIG. 34-1

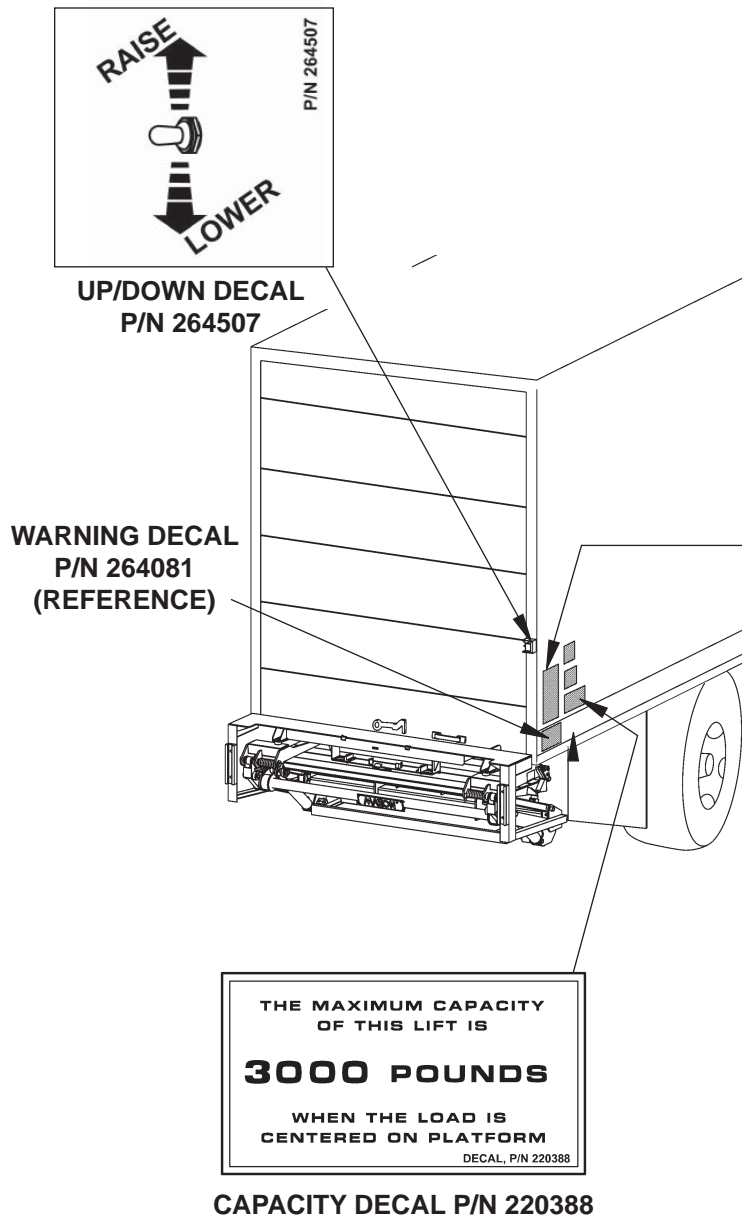

OPERATING INSTRUCTIONS

GPT & 80 SERIES LIFTGATES

- 1** UNHOOK SAFETY CHAIN.
(SEE CAUTION DECAL.)
- 2** PUSH CONTROL SWITCH
(MUST TOUCH THE GROUND)
- 3** UNFOLD PLATFORM.
- 4** UNFOLD FLIPOVER.
- 5** USE SWITCH TO RAISE / LOWER.
- 6** TO TUCK UNIT AWAY REVERSE STEPS
1, 2, 3, & 4.
DECAL, P/N 251838

INSTRUCTION DECAL
P/N 251838

MAXON 11921 Slauson Ave. Santa Fe Springs, CA. 90670 (800) 227-4116 FAX (888) 771-7713

FIG. 35-1

DECALS - Continued

MAXON®

11921 Slauson Ave. Santa Fe Springs, CA. 90670 (800) 227-4116 FAX (888) 771-7713

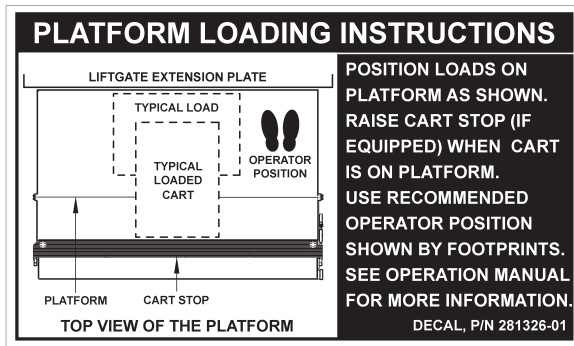

**INSTRUCTION DECAL (2 PLACES)
P/N 281326-01**

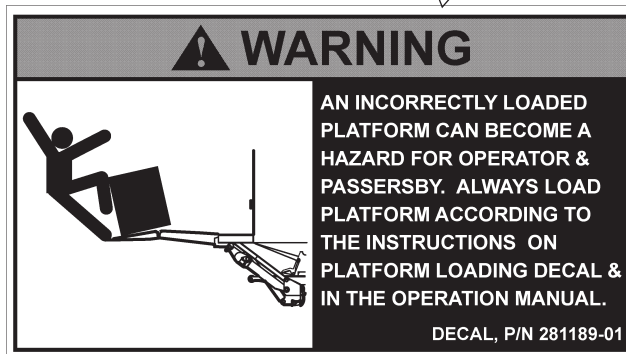
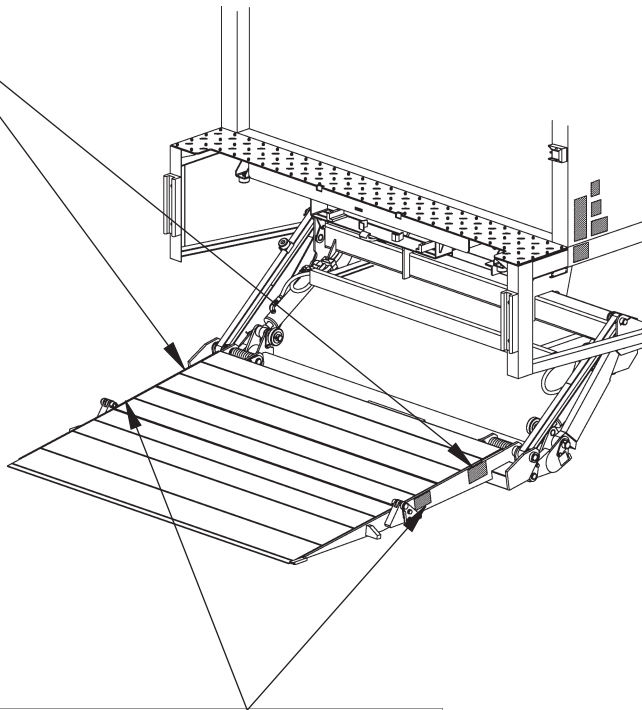

**WARNING DECAL (2 PLACES)
P/N 281189-01**

FIG. 36-1

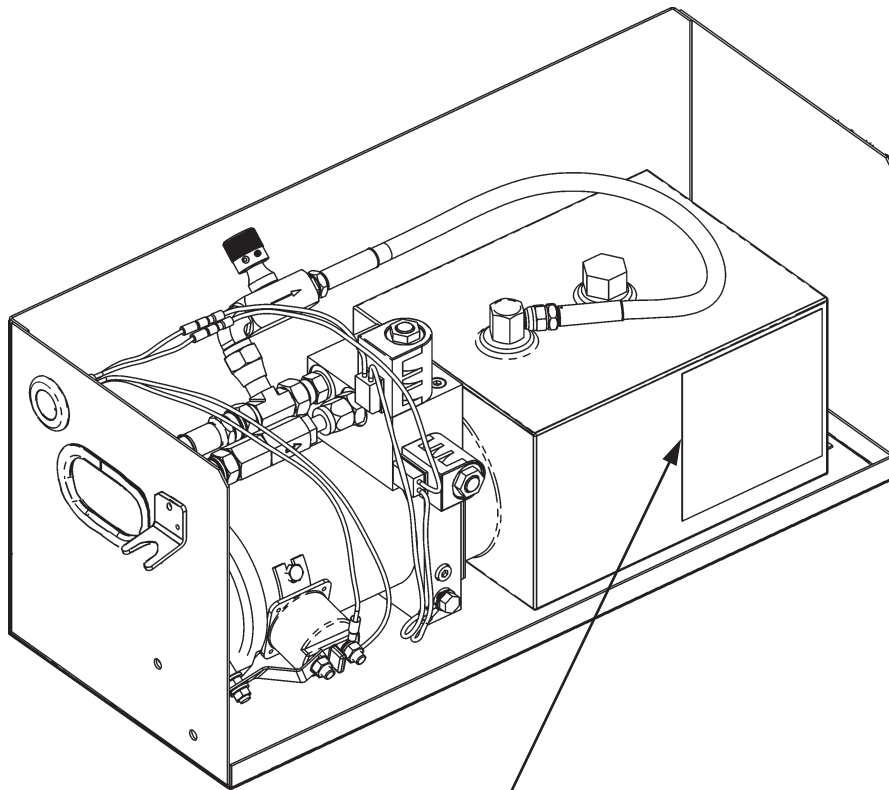

HYDRAULIC FLUID LEVEL

FILL LEVEL



1. Platform must be open and on the ground to check hydraulic fluid level (see illustration). Remove Filler Cap and look in filler hole. Reservoir is full if fluid level is even with top of **FILL LEVEL** bar.

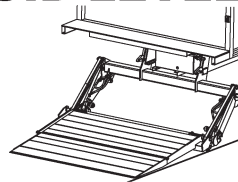

2. If fluid level is lower than top of **FILL LEVEL** bar, add hydraulic fluid (see **SPECS**). Fill until fluid level is even with top of **FILL LEVEL** bar. Re-install Filler Cap.

HYDRAULIC FLUID GRADES	
	+140°F Use +70°F ISO - 32
	+105°F Use +40°F ISO - 15
	+70°F & Below Use ISO - 10 or MIL - H - 5606

P/N 265330-03

FLUID LEVEL DECAL
P/N 265330-03

FIG. 37-1

SYSTEM DIAGRAMS

HYDRAULIC SCHEMATIC - POWER DOWN

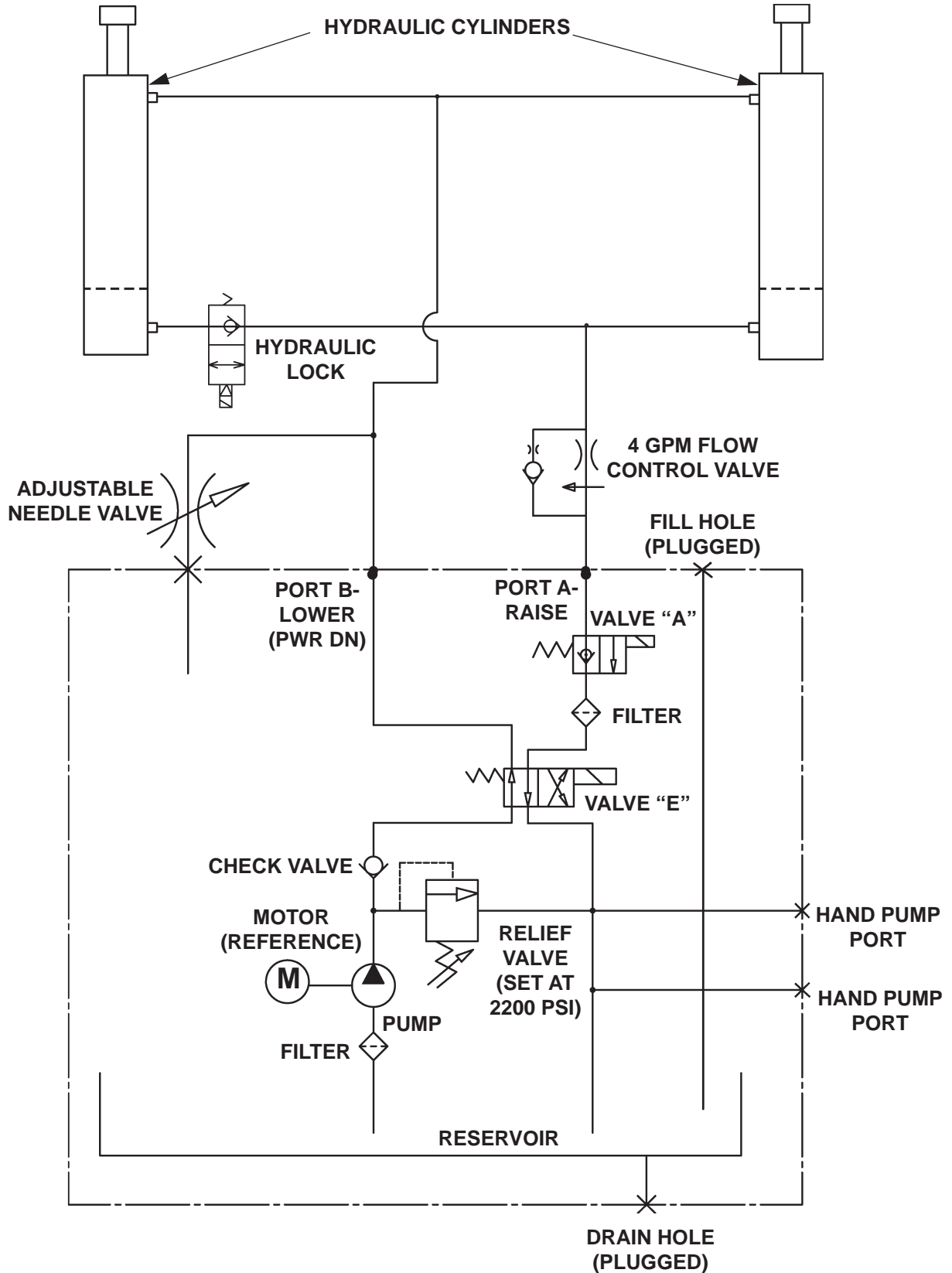

FIG. 38-1

ELECTRICAL SCHEMATIC - POWER DOWN

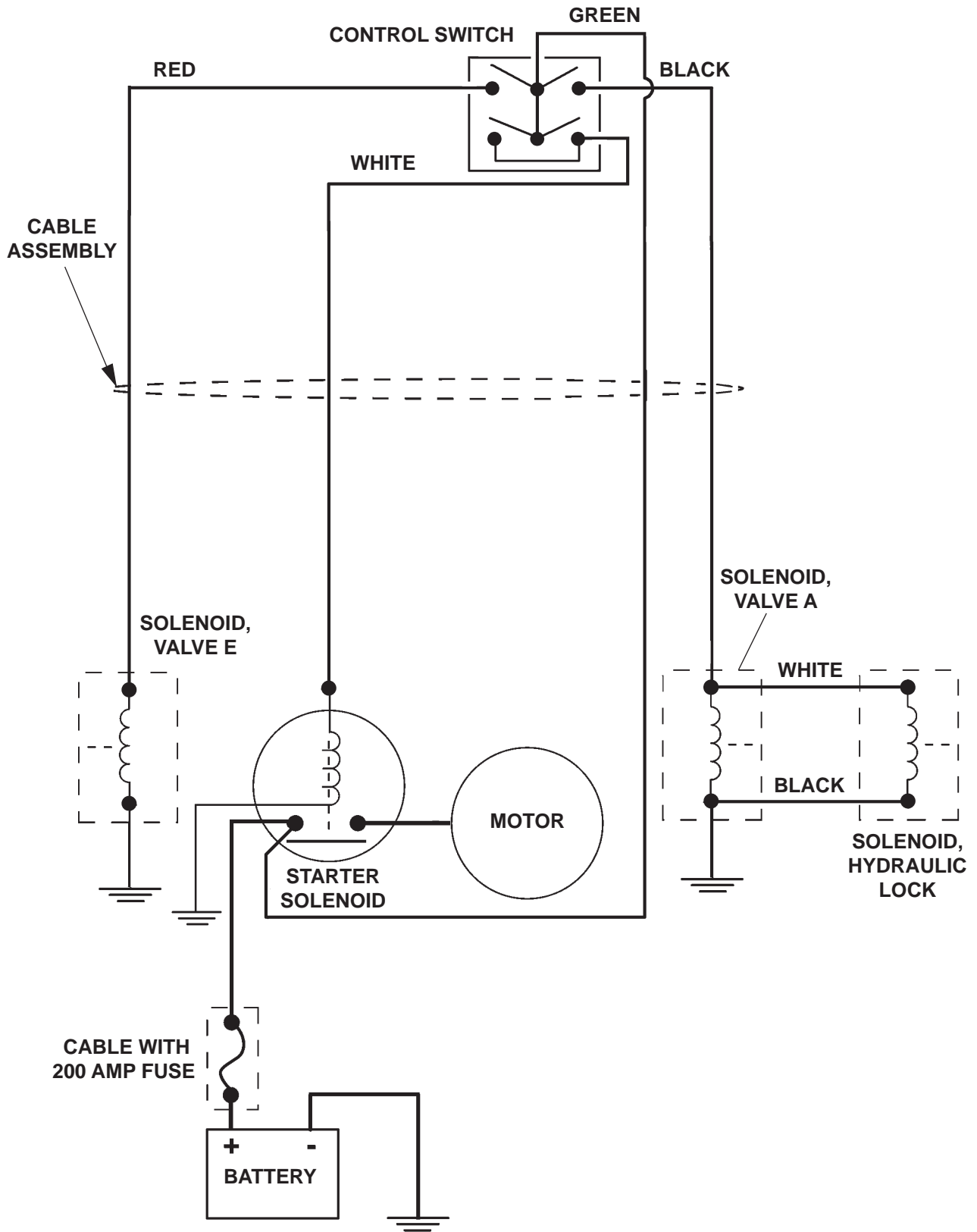

FIG. 39-1

TROUBLESHOOTING

PLATFORM WILL NOT RAISE

1. Connect voltmeter between Motor Solenoid Terminal “A” and Bracket (**FIG. 40-1**) to verify that battery power is getting to “A”. Recharge the battery if voltmeter indicates less than 12.6 Volts DC.

CAUTION

Keep dirt, water and other contaminants from entering the hydraulic system. Before opening the hydraulic fluid reservoir filler cap, drain plug and hydraulic lines, clean up contaminants that can get in the openings. Also, protect the openings from accidental contamination during maintenance.

2. Fill Reservoir to fill line shown on decal, with the hydraulic fluid recommended in the Periodic Maintenance Checklist.
3. Touch a jumper wire to terminals “A” & “C” (**FIG. 40-1**). If motor runs check Switch, the switch connections, and White wire. Check and correct wiring connections or replace the Switch.
4. Touch heavy jumper cables to terminals “A” & “B” (**FIG. 40-1**).
 - a. If motor runs, replace the motor solenoid.
 - b. If motor does not run, repair or replace the pump motor.

NOTE: In most cases, you can avoid having to manually bleed Hydraulic System by correctly positioning Liftgate Platform before disconnecting any Lifting Cylinder high pressure Hydraulic Lines. The following procedure can save time and prevent accidental fluid spills and hazards.

5. Check for structural damage and replace worn parts.
6. Check filter in the pump Reservoir. Replace filter if necessary.
7. Check for dirty pump motor relief valve. Clean if necessary. Replace any worn out relief valve parts.

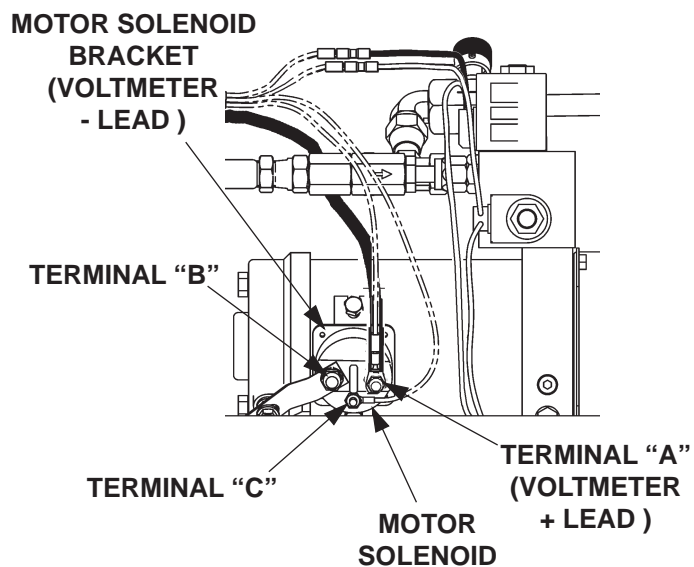

FIG. 40-1

PLATFORM RAISES BUT LEAKS DOWN

1. Check if Lowering Solenoid Valve is constantly energized. Connect voltmeter negative (-) lead to Motor Solenoid bracket and positive (+) lead to Motor Solenoid terminal "C" (FIG. 41-1). If voltmeter reads battery voltage (+12.6 Volts DC minimum) without pushing the toggle switch, the control circuit is operating incorrectly. Check if toggle switch, wiring or coil are faulty.

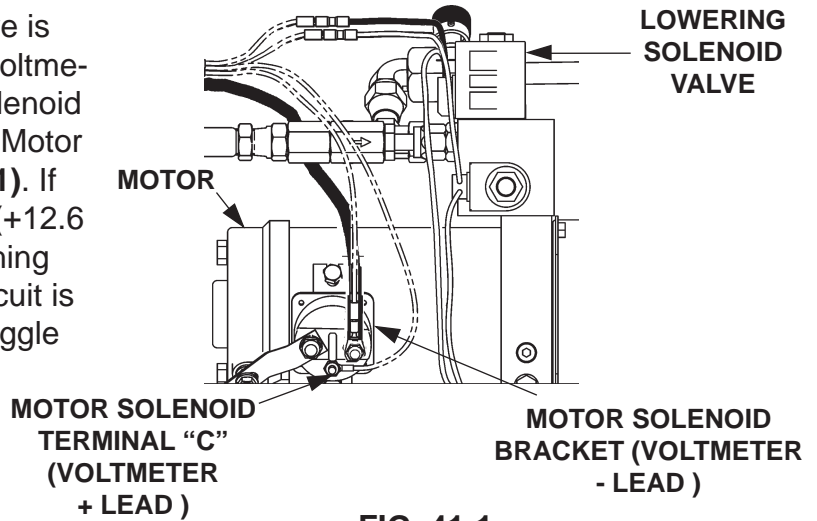

FIG. 41-1

CAUTION

Keep dirt, water and other contaminants from entering the hydraulic system. Before opening the hydraulic fluid reservoir filler cap, drain plug and hydraulic lines, clean up contaminants that can get in the openings. Also, protect the openings from accidental contamination during maintenance.

NOTE: In most cases, you can avoid having to manually bleed Hydraulic System by correctly positioning Liftgate Platform before disconnecting any Lifting Cylinder high pressure Hydraulic Lines. The following procedure can save time and prevent accidental fluid spills and hazards.

2. Check the Valve Stem by removing the Coil Assembly (Item 1, FIG. 41-2). With platform on ground, unscrew the Valve Stem, (Item 2, FIG. 41-2) from the Pump. Push on the plunger that is located inside the Valve Stem by inserting a small screwdriver blade in the end. If the Plunger does not move freely (approximately 1/8") replace the Valve Stem. **When reinstalling valve stem, torque hex nut to 30 in-lbs.**

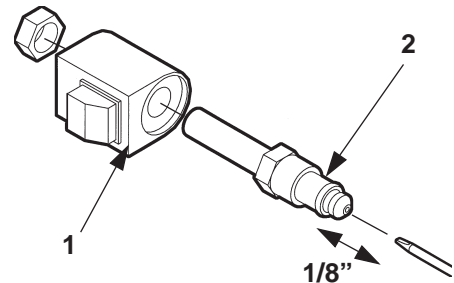

FIG. 41-2

3. Check the Hydraulic Cylinder. With the Platform on the ground, remove the hydraulic line from the Lower Port of the Cylinder (FIG. 41-3). Raise the Platform even with the bed. Allow pump motor to run two seconds more while you watch for hydraulic fluid at the Lower Port. A few drops of hydraulic fluid escaping the port is normal; however, if it streams out, Piston Seals are worn. Replace Seals.

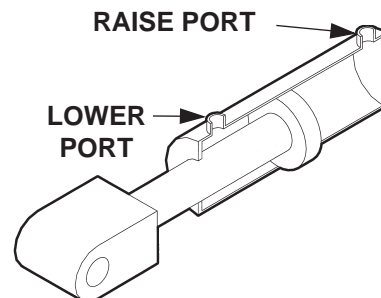

FIG. 41-3

PLATFORM RAISES PARTIALLY AND STOPS

CAUTION

Keep dirt, water and other contaminants from entering the hydraulic system. Before opening the hydraulic fluid reservoir filler cap, drain plug and hydraulic lines, clean up contaminants that can get in the openings. Also, protect the openings from accidental contamination during maintenance.

1. Lower the opened Platform to the ground. Do the Checking Hydraulic Fluid procedure in this manual.
2. Use voltmeter to verify that the Battery shows 12.6 volts or more.
3. Check for Structural damage, or poor lubrication. Replace worn parts.

NOTE: In most cases, you can avoid having to bleed the hydraulic system by correctly positioning Liftgate Platform before opening hydraulic lines. Refer to following procedure. Save time on the job and prevent accidental fluid spills and hazards.

4. Check the Hydraulic Cylinder. With the Platform on the ground, remove Line from the Lower Port of the Cylinder (**FIG. 42-1**). Allow pump motor to run two seconds more while you watch for hydraulic fluid at the Lower Port. A few drops of hydraulic fluid escaping the port is normal; however, if it streams out, Piston Seals are worn. Replace Seals.
5. Check Filter in the Pump Reservoir. Replace filter if necessary.
6. Check for dirty pump motor relief valve. Clean if necessary. Replace any worn out relief valve parts.

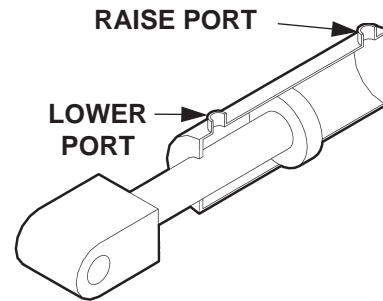

FIG. 42-1

MAXON[®]

11921 Slauson Ave. Santa Fe Springs, CA. 90670 (800) 227-4116 FAX (888) 771-7713

LIFTGATE WILL NOT LIFT RATED CAPACITY

1. Use voltmeter to verify that the Battery shows 12.6 volts or more under load from pump motor.
2. Check for Structural damage or lack of lubrication. Replace worn parts.

CAUTION

Keep dirt, water and other contaminants from entering the hydraulic system. Before opening the hydraulic fluid reservoir filler cap, drain plug and hydraulic lines, clean up contaminants that can get in the openings. Also, protect the openings from accidental contamination during maintenance.

NOTE: In most cases, you can avoid having to bleed the hydraulic system by correctly positioning Liftgate Platform before opening hydraulic lines. Refer to following procedure. Save time on the job and prevent accidental fluid spills and hazards.

3. With Platform on the ground, remove the pressure hose and fitting from the Pump and replace it with a 0-3000 PSI Pressure Gauge. Hold the switch in the "UP" position. Adjust the Relief Valve on the side of the Pump until the gauge shows 2200 PSI (**FIG. 43-2**). Remove gauge and reinstall pressure hose.

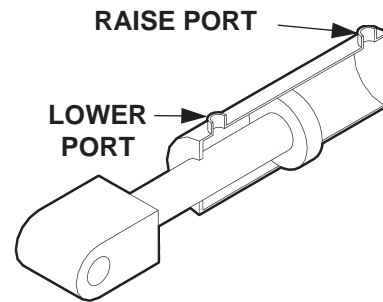

FIG. 43-1

4. Check for dirty pump motor relief valve. Clean if necessary. Replace any worn out relief valve parts.
5. Check the Hydraulic Cylinder. With the Platform on the ground, remove the hydraulic line from the Lower Port of the Cylinder (**FIG. 43-1**). Raise the Platform even with the bed. Allow pump motor to run two seconds more while you watch for hydraulic fluid at the Lower Port. A few drops of hydraulic fluid escaping the port is normal; however, if it streams out, Piston Seals are worn. Replace Seals.

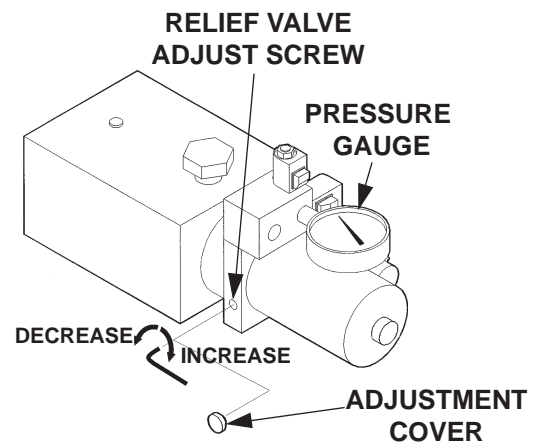

FIG. 43-2

6. If Pump cannot produce 2200 PSI with a minimum of 12.6 Volts available, the Pump is worn and needs to be replaced.

PLATFORM RAISES SLOWLY

1. Connect voltmeter between Motor Solenoid Terminal "A" and Bracket (**FIG. 44-1**) to verify that battery power is getting to "A". Recharge the battery if voltmeter indicates less than 12.6 Volts DC.

CAUTION

Keep dirt, water and other contaminants from entering the hydraulic system. Before opening the hydraulic fluid reservoir filler cap, drain plug and hydraulic lines, clean up contaminants that can get in the openings. Also, protect the openings from accidental contamination during maintenance.

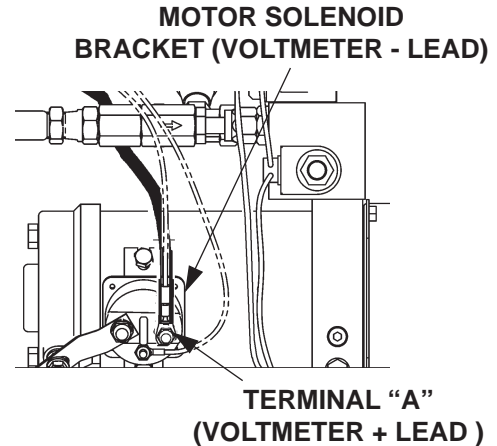

FIG. 44-1

2. Check the Hydraulic Cylinder. With the Platform on the ground, remove the hydraulic line from the Lower Port of the Cylinder (**FIG. 44-2**). Raise the Platform even with the bed. Allow pump motor to run two seconds more while you watch for hydraulic fluid at the Lower Port. A few drops of hydraulic fluid escaping the port is normal; however, if it streams out, Piston Seals are worn. Replace Seals.

NOTE: In most cases, you can avoid having to bleed the hydraulic system by correctly positioning Liftgate Platform before opening hydraulic lines. Refer to following procedure. Save time on the job and prevent accidental fluid spills and hazards.

3. Check and clean Flow Control Valve (**FIG. 44-3**) in high pressure hydraulic line connected to Pump. When installing Flow Control Valve make sure arrow on valve is oriented as shown in **FIG. 44-3**.

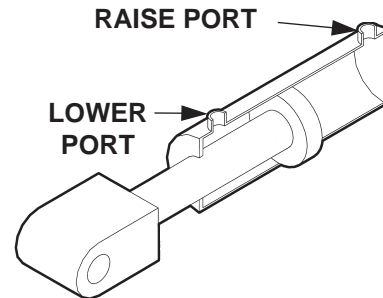

FIG. 44-2

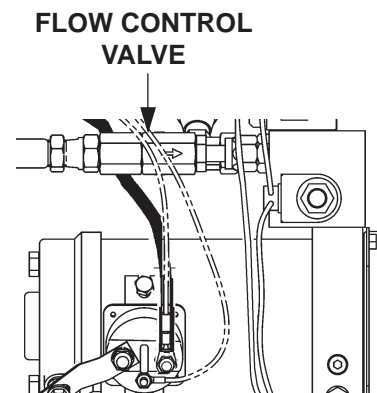

FIG. 44-3

4. Verify the Pump Motor is grounded to vehicle frame.
5. Check for leaking hoses and fittings. Tighten or replace as required.
6. Check for structural damage or poor lubrication. Replace worn parts.
7. Check the Filter in the Pump Reservoir. Replace if necessary.
8. With Platform on the ground, remove the pressure hose and fitting from the Pump and replace it with a 0-3000 PSI Pressure Gauge. Hold the Control switch in the "RAISE" position. Adjust the Relief Valve on the side of the Pump until the gauge shows 2200 PSI (**FIG. 45-1**). Remove gauge and reinstall pressure hose.

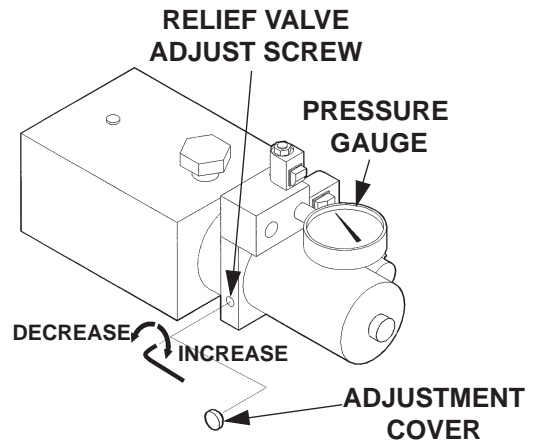
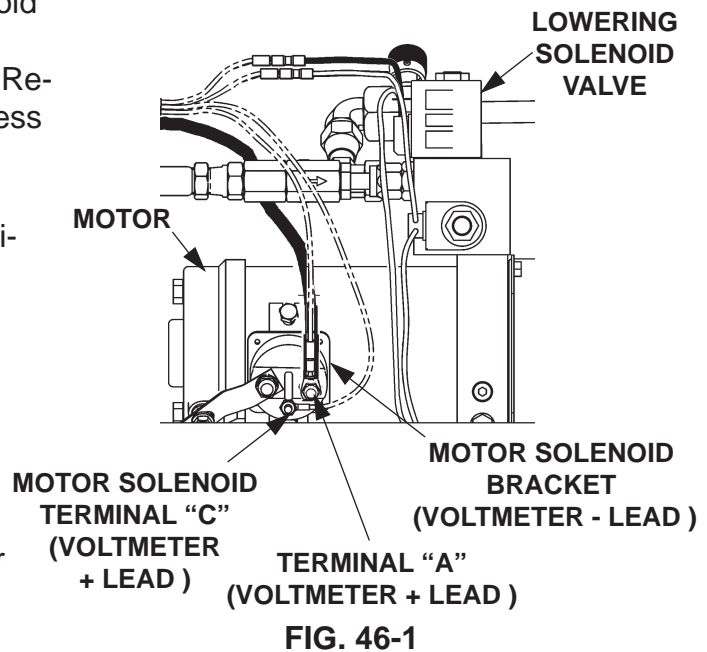

FIG. 45-1

PLATFORM WILL NOT LOWER, LOWERS TOO SLOWLY, OR LOWERS TOO QUICKLY

1. Connect voltmeter between Motor Solenoid Terminal "A" and Bracket (**FIG. 46-1**) to verify that battery power is getting to "A". Re-charge the battery if voltmeter indicates less than 12.6 Volts DC.
2. Check for structural damage or poor lubrication. Replace worn parts.
3. Check if Lowering Solenoid Valve is getting power. Connect voltmeter between Motor Solenoid Bracket and Motor Solenoid terminal "C" (**FIG. 46-1**). Push Control Switch to "LOWER" position to energize Lowering Solenoid. If voltmeter reads battery voltage (+12.6 Volts DC minimum), control circuit is operating correctly (replace Lowering Solenoid). If voltmeter reads 0 Volts, check if toggle switch and wiring are faulty.



CAUTION

Keep dirt, water and other contaminants from entering the hydraulic system. Before opening the hydraulic fluid reservoir filler cap, drain plug and hydraulic lines, clean up contaminants that can get in the openings. Also, protect the openings from accidental contamination during maintenance.

NOTE: In most cases, you can avoid having to bleed the hydraulic system by correctly positioning Liftgate Platform before opening hydraulic lines. Refer to following procedure. Save time on the job and prevent accidental fluid spills and hazards.

4. Check the Valve Stem by removing the Coil Assembly (**Item 1, FIG. 46-2**). With platform supported, unscrew the Valve Stem (**Item 2, FIG. 46-2**) from the Pump. Push on the plunger located inside the Valve Stem by inserting a small screwdriver blade in the end. If the Plunger does not move freely (approximately 1/8") replace the Valve Stem.
5. Check if filtering screen on solenoid valve is plugged. Clean carefully if required.

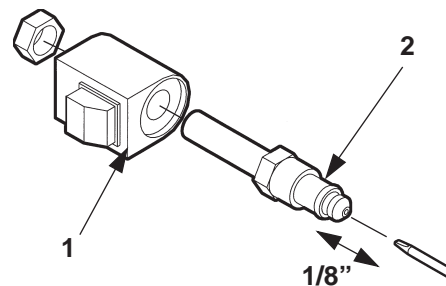

6. Check and clean Flow Control Valve (**FIG. 47-1**) in the high pressure hydraulic line connected to Pump.

7. Check if Flow Control Valve (**FIG. 47-1**) is pointing to the direction of restricted fluid flow (back toward pump). If required, remove Flow Control Valve and install it correctly (**FIG. 47-1**).

**FLOW CONTROL
VALVE**

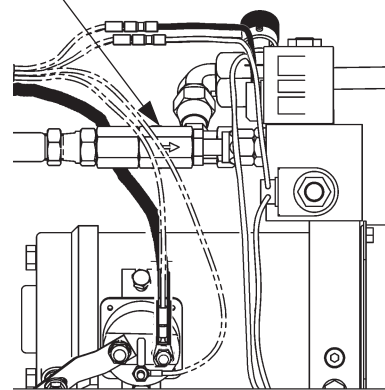
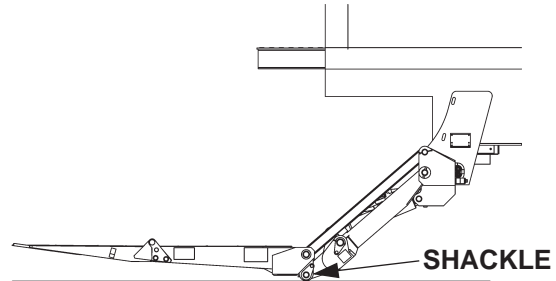

FIG. 47-1

PLATFORM WON'T TILT DOWN TO THE GROUND

NOTE: If the Liftgate is not damaged, the adjustable Flow Control Valve on Power Unit may need to be adjusted as follows.

1. Lower the Platform until shackles touch the ground (**FIG. 48-1**).



SHACKLES TOUCHING THE GROUND
FIG. 48-1

CAUTION

To prevent damage to adjustable Flow Control Valve, loosen locking screw before turning knob.

2. Open the Pump Box (**FIG. 48-2A**) to access the adjustment knob on the adjustable Flow Control Valve (**FIG. 48-2B**).

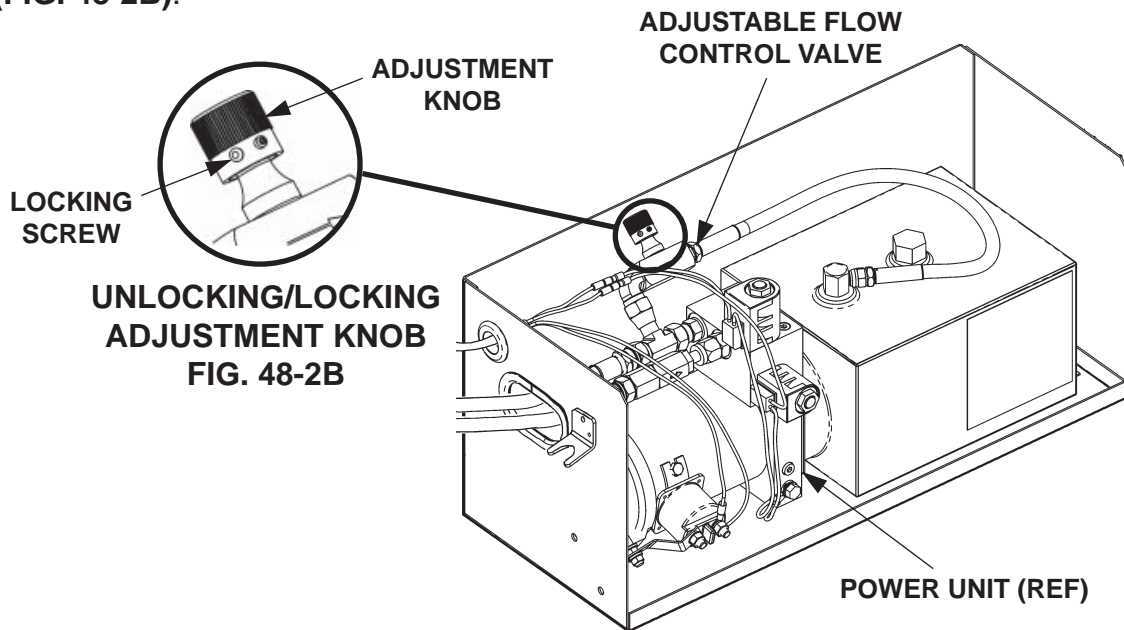

PUMP BOX & POWER UNIT
FIG. 48-2A

3. Loosen locking screw on the Flow Control Valve adjustment knob (**FIG. 48-2B**).

MAXON[®]

11921 Slauson Ave. Santa Fe Springs, CA. 90670 (800) 227-4116 FAX (888) 771-7713

4. First, close the adjustable Flow Control Valve (**FIG. 49-1A**) by turning adjustment knob full clockwise (**CW**) (**FIG. 49-1B**).

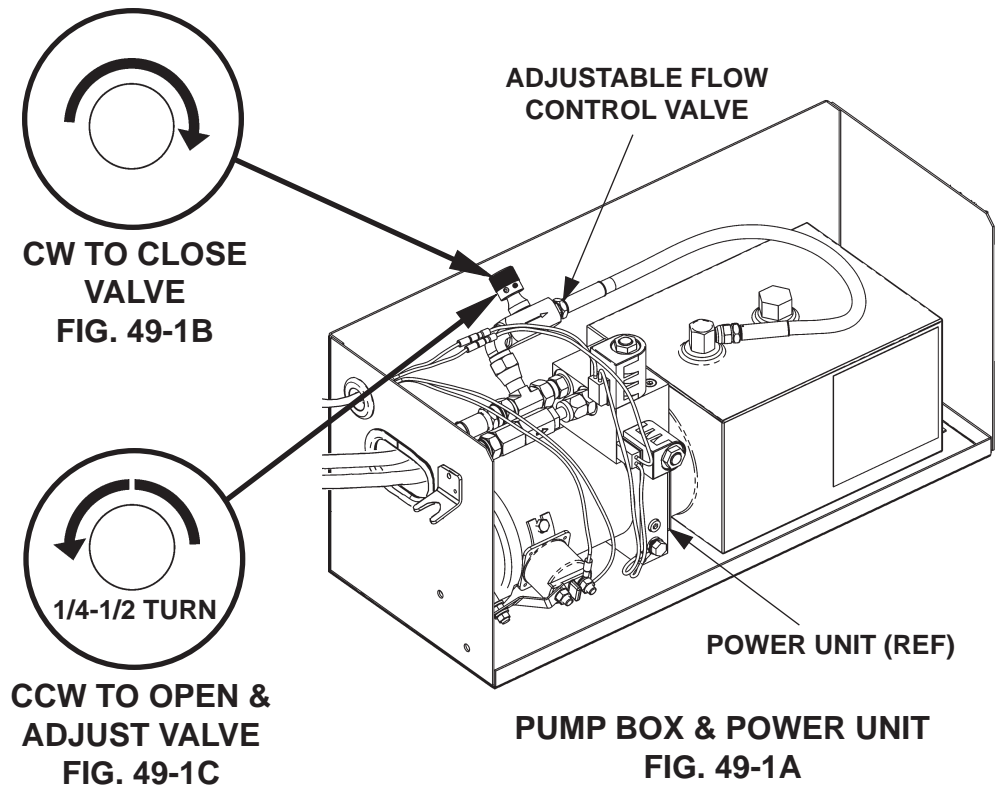

5. Next, open the Flow Control Valve a little by turning the adjustment knob 1/4 to 1/2 turn counter-clockwise (**CCW**) (**FIG. 49-1C**).

6. Push the Control Switch to **LOWER** position. Verify that Platform tilts down to the ground (**FIG. 49-2**).

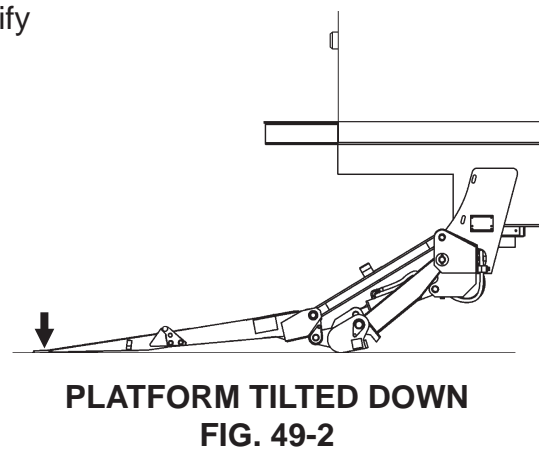

7. Tighten locking screw on the Flow Control Valve adjustment knob (**FIG. 48-2B**).

