

M-99-46
REV. 2
APRIL, 2000

MAINTENANCE MANUAL

CONVENTIONAL

LIFTGATE SERIES

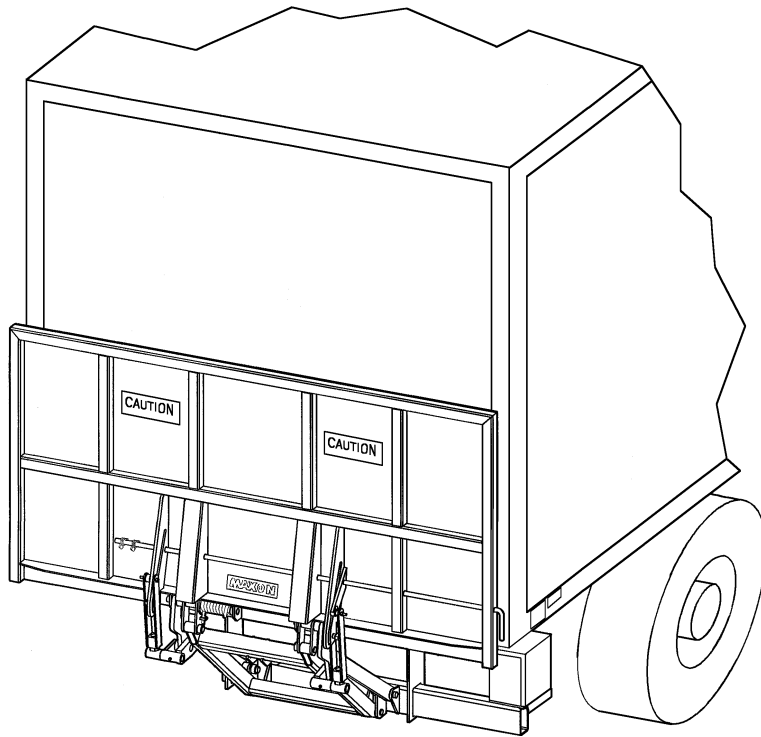

TG-150 LMV

TG-20 LMV

MAXON[®]
LIFT CORP.

11921 Slauson Avenue.
Santa Fe Springs, CA. 90670
(800) 227-4116

MAXON[®]

LIFT CORP.

**11921 Slauson Ave.
Santa Fe Springs, CA. 90670**

CUSTOMER SERVICE:

TELEPHONE (562) 464-0099 TOLL FREE (800) 227-4116

FAX: (888) 771-7713

**NOTE: Check with Customer Service for updated versions
of Manuals on an annual basis.**

WARRANTY POLICY & PROCEDURE

NEW LIFTGATE WARRANTY

Term of Warranty: 2 Years from Date of In-Service

Type of Warranty: Full Parts and Labor

MAXON agrees to replace any components which are found to be defective during the first 2 years of service, and will reimburse for labor based on MAXON's Liftgate Warranty Flat Rate Labor Schedule. (Call MAXON Customer Service for a copy).

All claims for warranty must be received within 30 Days of the repair date, and include the following information:

1. Liftgate Model Number
2. Liftgate Serial Number
3. Detailed Description of Problem
4. Corrective Action Taken, and Date of Repair.
5. Parts used for Repair, Including MAXON Part Number(s).
6. MAXON R.M.A. # and/or Authorization # if applicable (see below).
7. Person contacted at MAXON if applicable.

All warranty repairs must be performed by an authorized MAXON warranty station. For major repairs, MAXON Customer Service must be notified and an "Authorization Number" obtained. Major repairs would generally be considered repairs made to the structural assembly of the liftgate and/or repairs not outlined in the MAXON Liftgate Warranty Flat Rate Schedule.

Major components (i.e. hydraulic pumps, cylinders, valves, or failed structural parts) must be returned, freight pre-paid, prior to the claim being processed. To ensure timely processing of these warranty claims, an R.M.A. (Returned Merchandise Authorization) number must be obtained from MAXON Customer Service prior to the return of any defective part. Defective Parts must be returned within 60 days of the claim date for consideration to:

**MAXON Lift Corp.
16205 Distribution Way, Cerritos, CA 90703
Attn: RMA#__**

MAXON's warranty policy does not include the reimbursement for travel time, towing, vehicle rental, service calls, oil, batteries, defects due to misuse or abuse, or loss of income due to downtime. Fabrication of parts, which are available from MAXON, are also not covered.

MAXON's Flat Rate Labor Schedule takes into consideration the time required for diagnosis of a problem.

PURCHASE PART WARRANTY

Term of Warranty: 1 Year from Date of Purchase

Type of Warranty: Part Replacement

MAXON will guarantee all returned genuine replacement parts upon receipt and inspection of parts and invoice.

Table of Contents

WARNING	PAGE 4
PERIODIC MAINTENANCE CHECKLIST	PAGE 5
DECALS	PAGE 6
CONTROL SWITCH GRAVITY DOWN	PAGE 7
ASSEMBLY DRAWING	PAGE 8
WIRE CONNECTIONS	PAGE 11
PUMP ASSEMBLY, GRAVITY DOWN	PAGE 12
HARNESS & SWITCH ASSEMBLY	PAGE 14
LOW VOLTAGE / THERMAL SWITCH (LVTS)	PAGE 15
TROUBLESHOOTING	PAGE 17
PLATFORM WILL NOT RAISE	PAGE 18
PLATFORM WILL NOT LOWER	PAGE 19
PLATFORM RAISES BUT LEAKS DOWN	PAGE 20
PLATFORM RAISES PARTIALLY AND STOPS	PAGE 21
LIFTGATE WILL NOT LIFT RATED CAPACITY	PAGE 22
PLATFORM RAISES SLOWLY	PAGE 23

WARNING

1. Read the **Maintenance Manual** and understand it thoroughly before any maintenance of this unit is done.
2. Read the **YELLOW** urgent warning decal on the side of the vehicle close to the unit before operating.
3. If decals are dirty, clean them. If decals are defaced or missing, replace them. **Free replacements** are available from the manufacturer. See information at the end of the Warnings
4. Be aware that the safety and location of other people or objects should be considered before operation of this unit. Stand to one side of platform while operating this unit. Do not stand in a position that would put you in the path of any moving vehicles around you.
5. Do not stand under, or have any foreign object under the Platform when lowering. **Be sure that the lowering of the Platform and/or Flipover will miss your feet!**
6. Keep fingers, hands, arms, legs, and feet clear of moving parts when operating this unit.
7. If during your maintenance procedure, it becomes necessary to ride the platform, keep your feet and any foreign objects clear of the rear edge of the platform. Otherwise your feet or the foreign objects could become trapped between the edge of the platform and the vehicle bed.
8. Inspect all Roll Pins monthly, to insure that they are not broken. Replace if broken.
9. Inspect all hydraulic hoses and fittings annually. Check for cracks and deterioration, and replace if necessary.
10. **Disconnect battery** when replacing parts or servicing.
11. Do not allow children to ride, play with, or operate this unit.
12. In the event of an emergency while operating the unit, release the toggle switch and the unit will stop immediately.
13. A properly installed Lift should operate smoothly and the only noise during the operation of this unit should be from the Pump Unit during the raising of the Platform. Any scraping, grating or audible indications of rough operation will need investigating. The cause will need resolving before any further deterioration of performance occurs.
14. Use only **Maxon Authorized Parts** for replacement. Replacement parts should be ordered from:

MAXON LIFT CORP. Parts Department
11921 Slauson Ave., Santa Fe Springs, Ca. 90670
Phone: (800) 227-4116

PERIODIC MAINTENANCE CHECKLIST

Annually

Visually check the complete unit for excessive wear, worn parts or broken welds. Check all Hinge Pins for excessive wear or broken welds. For parts replacement, see the Assembly Breakdown Drawings.

Six Months

Visually check the Platform Hinge Pins for excessive wear or broken welds. For parts replacement, see the Assembly Breakdown Drawings.

Quarterly

Check the oil in the Pump Reservoir. The oil should be Grade ISO-(32) Hydraulic Fluid. ***See below for Cold Weather operation.**

Check Hoses and Fittings for scuffing and leaks. Replace if necessary.

Check the electrical wiring for worn insulation, and the terminals for corrosion and secure fit.

Check all bolts for tightness.

Check that all Warning Decals are in place and readable.

Check that all roll pins are properly installed. Replace if necessary.

Inspect the Hook & Chain Assembly for proper operation.

* COLD WEATHER OPERATION

OIL SPECIFICATIONS:

Grade ISO-(32)
Gravity, API - 29.5 Degrees
Pour Point, F- (-54 Degrees)

VISCOSITY:

@ 40 Degrees C - 31.2 cSt
@100 Degrees C - 6.2 cSt
VISCOSITY INDEX - 154 VI
Flash Point, F - 325 Degrees

MAXON

11921 Slauson Ave. Santa Fe Springs, CA. 90670 (800) 227-4116 FAX (888) 771-7713

DECALS

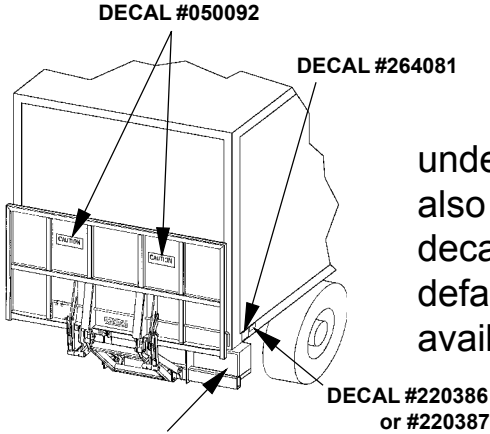

These Decals should be read and completely understood before operating the unit. They should also be kept clean and readable at all times. If any decal should become detached from the vehicle, or defaced, it must be replaced. Free replacements are available from: MAXON Lift Corp., Parts Department.

Locate DECAL #801358 on Reservoir

Suggested Decal Locations

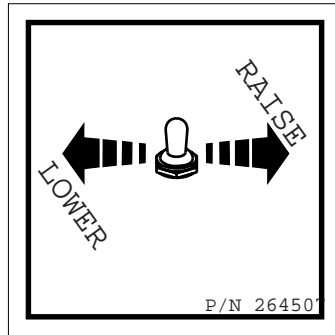

CAUTION!
STAND CLEAR
P/N 050092

CAUTION!
DO NOT USE BRAKE FLUID...
USE: No. 10W S.A.E. Motor Oil
Hydraulic Hoist Oil
Type "A" Transmission Fluid
"Fill only when lift is lowered to ground"
P/N 801358

THE MAXIMUM CAPACITY OF THIS LIFT IS
1500 LBS.
WHEN THE LOAD IS CENTERED ON THE LOAD CARRYING PLATFORM
P/N 220386

THE MAXIMUM CAPACITY OF THIS LIFT IS
2000 LBS.
WHEN THE LOAD IS CENTERED ON THE LOAD CARRYING PLATFORM
P/N 220387

WARNING
READ CAREFULLY

- Improper operation of this Lift can result in serious personal injury. Do not operate unless you have been properly instructed and have read, and are familiar with the operating instructions. If you do not have a copy of the instructions, please obtain them from your employer, distributor, or lessor, before you attempt to operate Lift.
- Be certain that the vehicle is properly and securely braked before using the Lift.
- Always inspect this Lift for maintenance or damage before using it. If there are signs of improper maintenance, damage to vital parts, or slippery Platform surface, do not use the Lift until these problems have been corrected.
- Do not overload the Lift. The load limit is based on evenly distributed cargo over the entire Platform surface. If you are using a pallet jack, be sure it can be maneuvered safely. Do not operate a forklift on the Platform or travel with the platform in an open position at any time.
- Load should be placed in a stable position close to the edge of the Platform nearest the truck. The heaviest portion of the load should never be placed beyond the center of the Platform away from the truck.
- Never allow yourself, a helper, or bystander to stand in a position where a falling load could land on either of you. Also do not allow any part of yours or your helper's body to be placed under, within, or around any portion of the moving liftgate, or its mechanisms, or in a position that would trap them between the platform and the ground or truck when the liftgate is operated.
- If a helper is riding the Platform with you, make sure you are both doing so safely and that you are not in danger of coming in contact with any moving or potentially moving obstacles. USE GOOD COMMON SENSE. If load appears to be unsafe, do not lift or lower it.

MAXON LIFT CORP. PART NO. 264081

CONTROL SWITCH GRAVITY DOWN

Assemble Switch to the vertical post as shown.

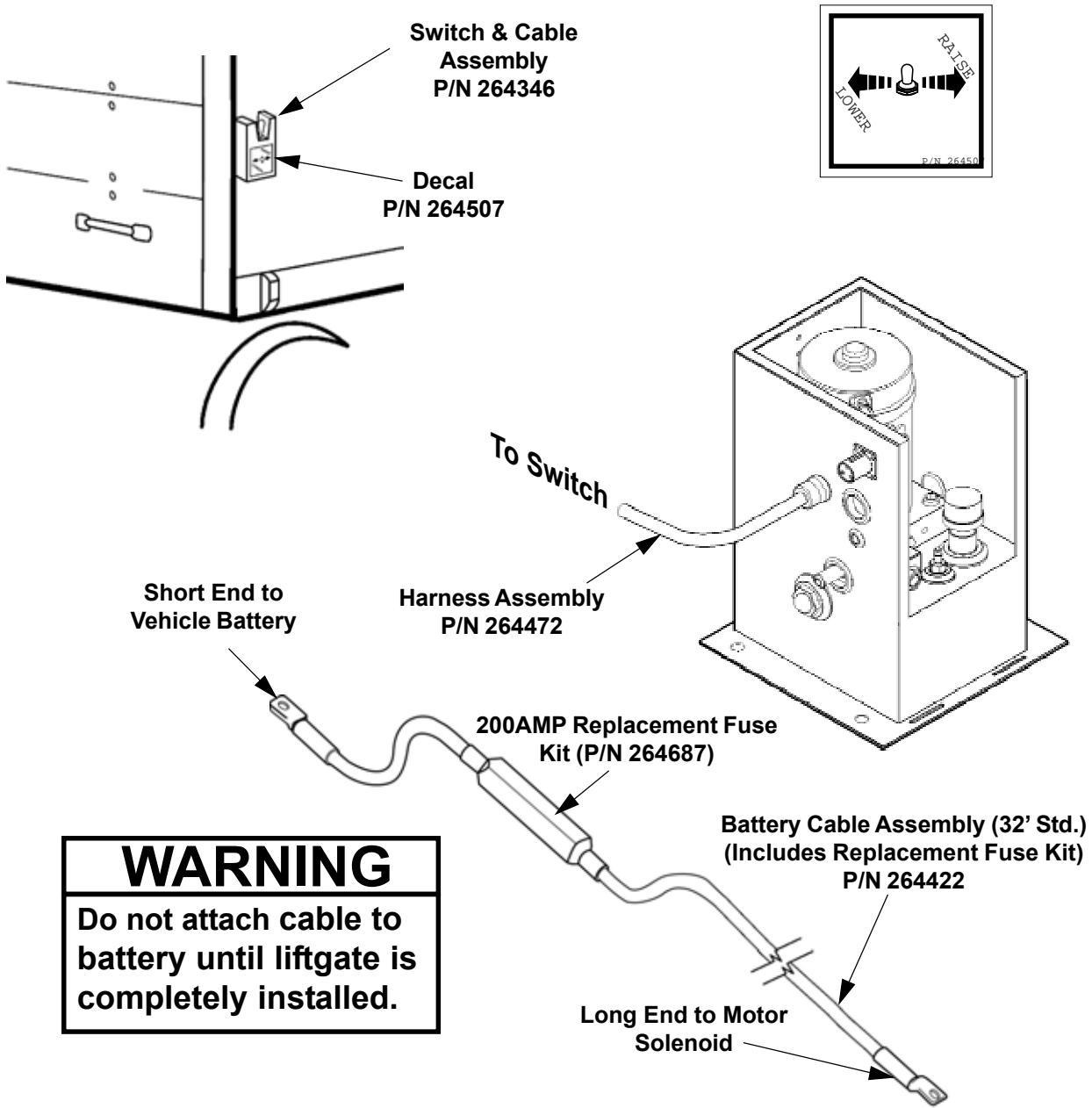

WARNING
Do not attach cable to battery until liftgate is completely installed.

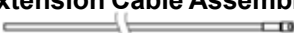
ADDITIONAL AVAILIABLE BATTERY CABLE KITS		
	PART NUMBER	
40' CABLE ASSEMBLY	264848	Cable Assembly 
10' EXTENSION CABLE ASSEMBLY	264849	Extension Cable Assembly 

MAXON 11921 Slauson Ave. Santa Fe Springs, CA. 90670 (800) 227-4116 FAX (888) 771-7713

ASSEMBLY DRAWING

MAXON[®]

11921 Slauson Ave. Santa Fe Springs, CA. 90670 (800) 227-4116 FAX (888) 771-7713

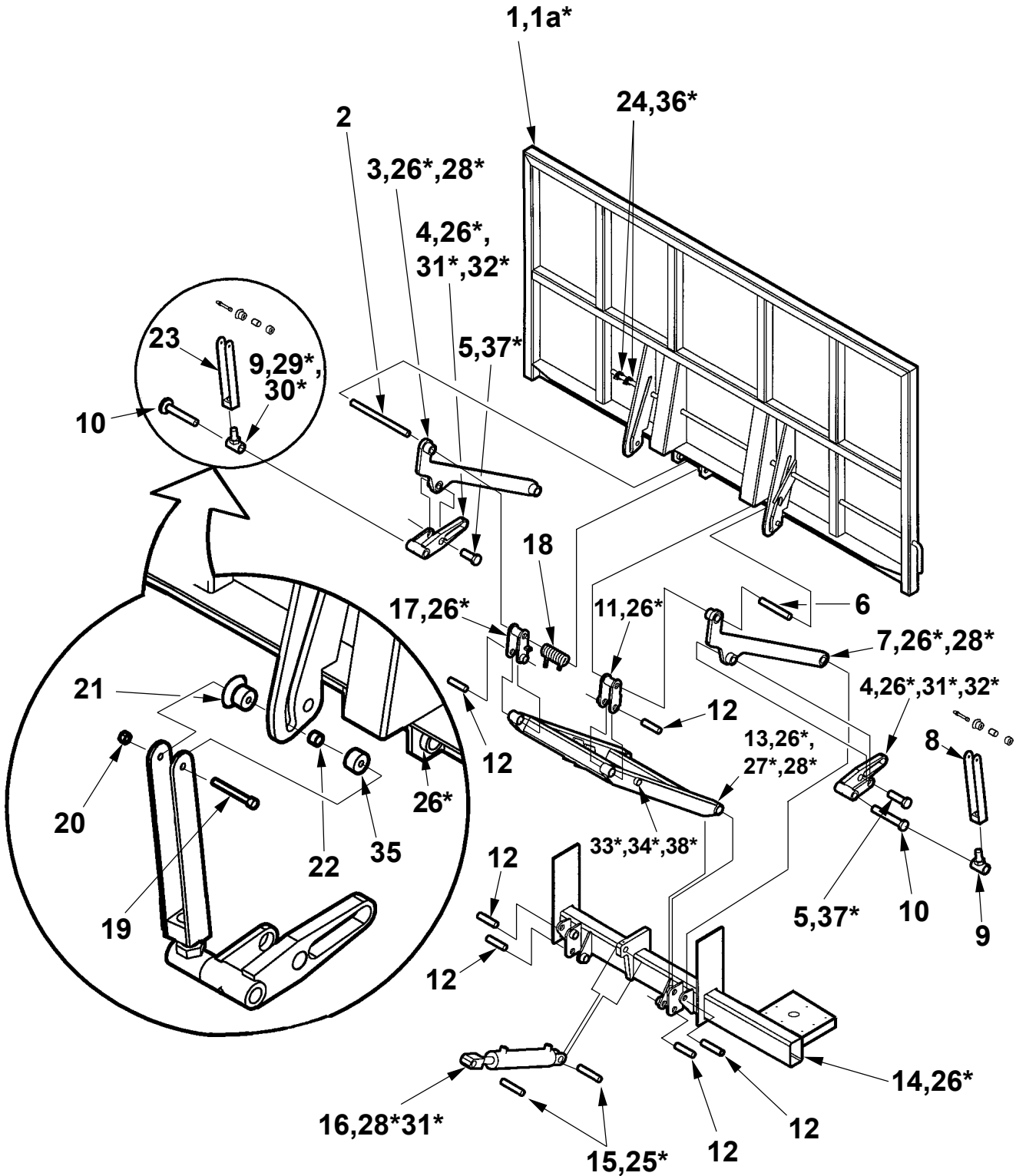

* = Not Shown

ASSEMBLY DRAWING

ITEM	QTY.	PART NUMBER	DESCRIPTION
1	1	261602-01	PLATFORM WELDMENT 36" x 80" WIDE
		261602-04	PLATFORM WELDMENT 42" x 80" WIDE
		261602-07	PLATFORM WELDMENT 48" x 80" WIDE
		261602-02	PLATFORM WELDMENT 36" x 86" WIDE
		261602-05	PLATFORM WELDMENT 42" x 86" WIDE
		261602-08	PLATFORM WELDMENT 48" x 86" WIDE
		261602-03	PLATFORM WELDMENT 36" x 92" WIDE
		261602-06	PLATFORM WELDMENT 42" x 92" WIDE
		261602-09	PLATFORM WELDMENT 48" x 92" WIDE
1a*	1	253944-02	RAMP, 6" FIXED x 80" WIDE
		253944-03	RAMP, 6" FIXED x 86" WIDE
		253944-05	RAMP, 12" FIXED x 80" WIDE
		253944-06	RAMP, 12" FIXED x 86" WIDE
		253830	RAMP, SINGLE CART STOP x 80" WIDE
		253830-01	RAMP, SINGLE CART STOP x 86" WIDE
		253890	RAMP, DUAL CART STOP x 80" WIDE
		253890-01	RAMP, DUAL CART STOP x 86" WIDE
2	1	252685	PIN, 1" DIA. x 13.75" LONG
3	1	252675-01	PARALLEL ARM WELDMENT L.H.
4	2	261582	ARM, PLATFORM CLOSER WELDMENT
5	2	261896-01	PIN WELDMENT, 1" DIA x 4.01" LONG
6	1	260830	PIN, 1" DIA. x 7.25" LONG
7	1	252675-02	PARALLEL ARM WELDMENT R.H.
8	1	260923	ARM, PUSHING ADJUST WELDMENT R.H.
9	2	261597	BOLT & BUSHING WELDMENT
10	2	261456-01	PIN WELDMENT, 1" DIA x 6.85" LONG
11	1	260815-02	SHACKLE WELDMENT, R.H.
12	6	252686	PIN, 1" DIA. x 4" LONG

(Continued on next page)

ASSEMBLY DRAWING

ITEM	QTY.	PART NUMBER	DESCRIPTION
13	1	260736-01	LIFT FRAME WELDMENT (TG-150/12/20)
14	1	260733-01	MAINFRAME WELDMENT (TG-150/20)
15	2	261895	PIN, 1" DIA. x 5.12" LONG
16	1	260372	CYLINDER, 3 x 10 x 1.25" ROD (TG-150)
		260392	CYLINDER, 3.5 x 10 x 1.25" ROD (TG-20)
17	1	260815-01	SHACKLE WELDMENT, L.H.
18	1	262228	SPRING, TORSION 1/2 x 6 11.25CL
19	2	900047	SHOULDER BOLT, 1/2" x 3/4" LG
20	2	040540	NUT, NYLON, 5/16-18 UNC
21	2	261454	SPACER, SLEEVE 1/2" DIA x 5/8" LG
		261455	ROLLER, TRAVEL, 3/4" DIA x 1/2" LG
22	2	905127-04	BEARING, SELF-LUBE, 3/8 x 5/8
23	1	260923-01	ARM, PUSHING ADJUST. WELDMENT L.H.
24	2	202528-02	SPRING, TORSION .160 x 1
25*	2	030159	COTTER PIN, 3/16 x 2
26*	14	221416	PIN, ROLL 3/8" x 2" ZINC
27*	2	221497	PIN, ROLL 3/8" x 1-1/2" ZINC
28*	7	260916-03	BEARING, SELF LUBE 1" x 2" LONG
29*	2	260916-02	BEARING, SELF LUBE 1" x 1-1/2" LONG
30*	2	260916-01	BEARING, SELF LUBE 1" x 1-1/4" LONG
31*	3	260916-06	BEARING, SELF LUBE 1" x 1" LONG
32*	2	260916-07	BEARING, SELF LUBE 1" x 1/2" LONG
33*	2	260917-01	BEARING, SELF LUBE 3/4" x 3/4" LONG
34*	2	252684	ROLLER
35	2	201966	ROLLER, YOKE #CYR 1-1/4S
36*	2	030410	PIN, ROLL, 1/4 x 1-1/2
37*	2	260930	RETAINING RING
38*	2	252683-01	PIN WELDMENT

MAXON[®]

11921 Slauson Ave. Santa Fe Springs, CA. 90670 (800) 227-4116 FAX (888) 771-7713

WIRE CONNECTIONS

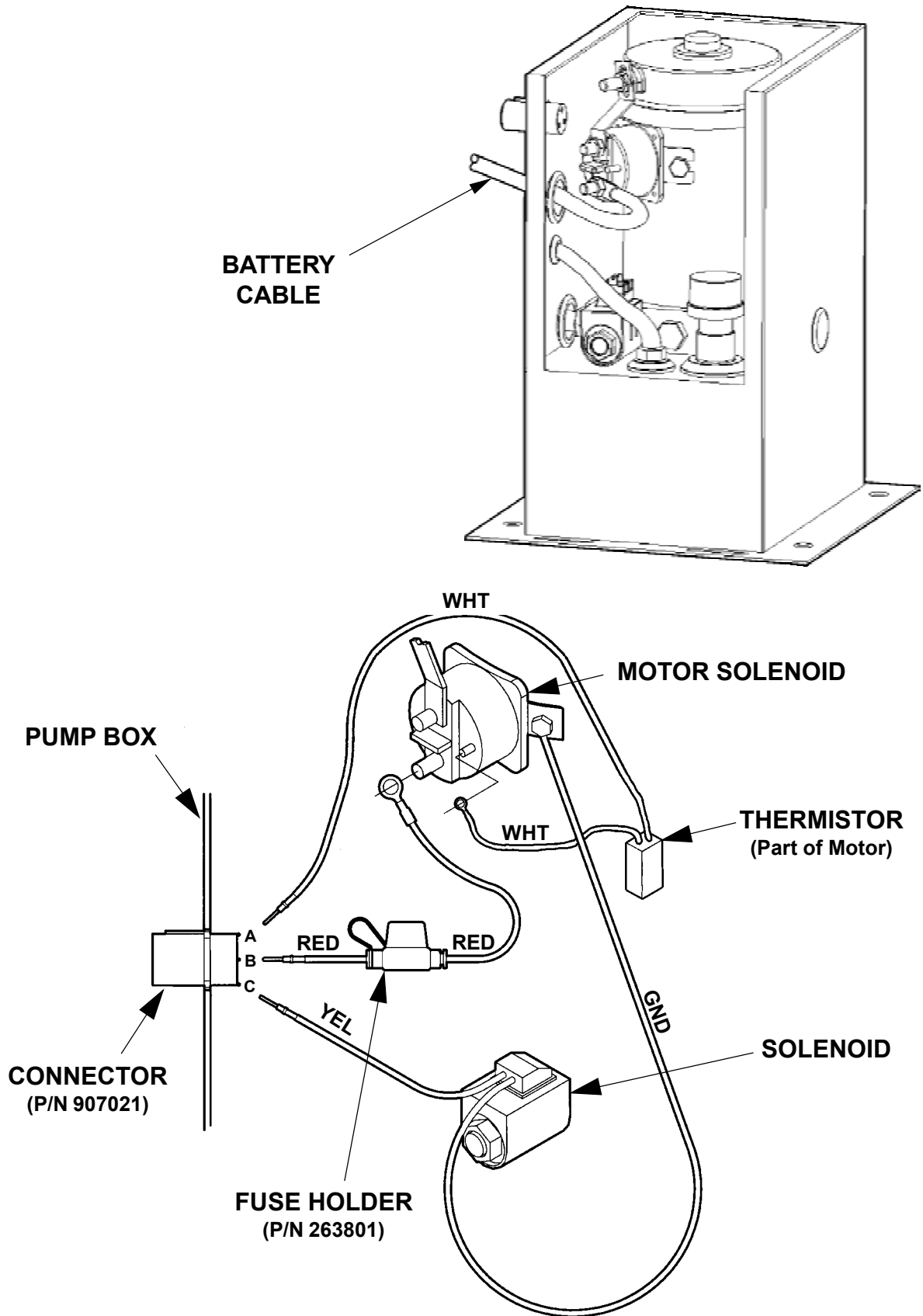

PUMP ASSEMBLY, GRAVITY DOWN

ITEM	QTY.	PART NO.	DESCRIPTION
1	1	263612	SLIMLINE PUMP ASSEMBLY 12 VDC
2	1	262966	BUS BAR
3	1	262939	MOTOR SOLENOID
4	1	253353	VALVE, SOLENOID, 2-WAY
4a	1	226594	O-RING KIT, 2-WAY VALVE
5	1	263779	PLUG
6	1	263369	FILLER
7	1	263811	CONNECTOR, 3/8"
8	1	263500	BOX ASSEMBLY
8a	1	263497	COVER
8b	1	263499	BOX WELDMENT
8c	1	263791	LATCH
9	1	030937	HEX PLUG, 1/4"
10	1	263370	FLOW SIGHT
11	2	263814	GROMMET, 1" DIA.
12	1	263795	GROMMET, 1/2" DIA.
13	1	263798	PUMP BOX HARNESS
13a	1	263802	GASKET
14	1	260250	FILTER
15	1	905100	BULKHEAD, MALE, JIC #6
16	2	030039	BOLT, 3/8-16 x 1-3/4" LG.
17	2	030555	WASHER, LOCK, 3/8"
18	2	030556	WASHER, FLAT, 3/8"

MAXON[®]

11921 Slauson Ave. Santa Fe Springs, CA. 90670 (800) 227-4116 FAX (888) 771-7713

PUMP ASSEMBLY, GRAVITY DOWN

P/N 263613

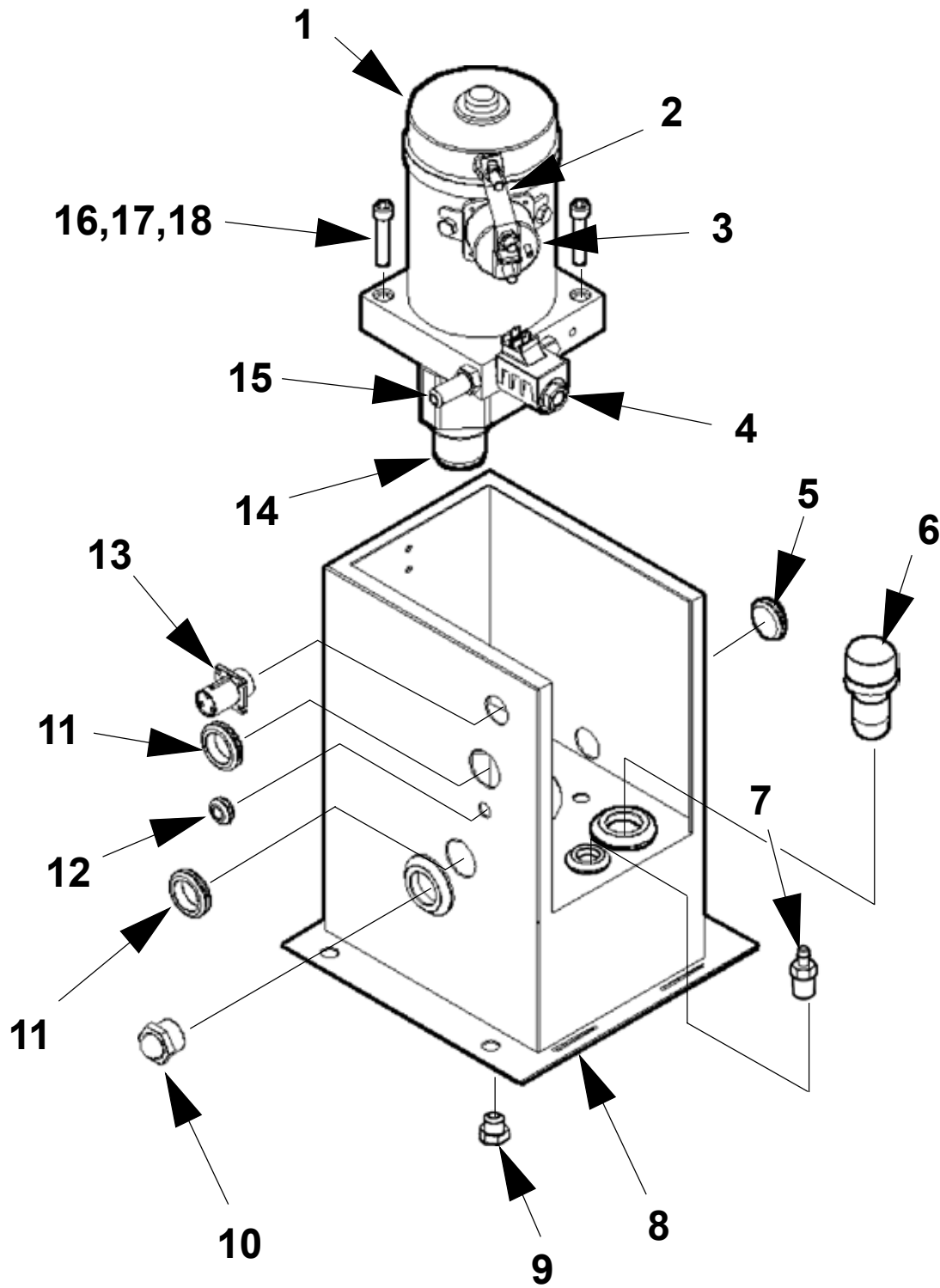

HARNESS & SWITCH ASSEMBLY

MAXON[®] 11921 Slauson Ave. Santa Fe Springs, CA. 90670 (800) 227-4116 FAX (888) 771-7713

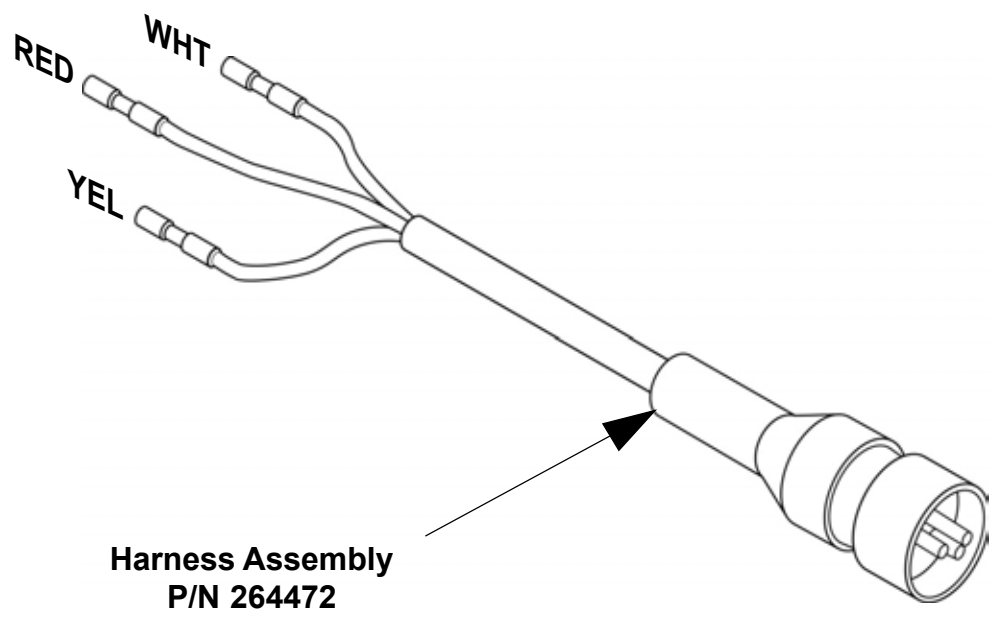
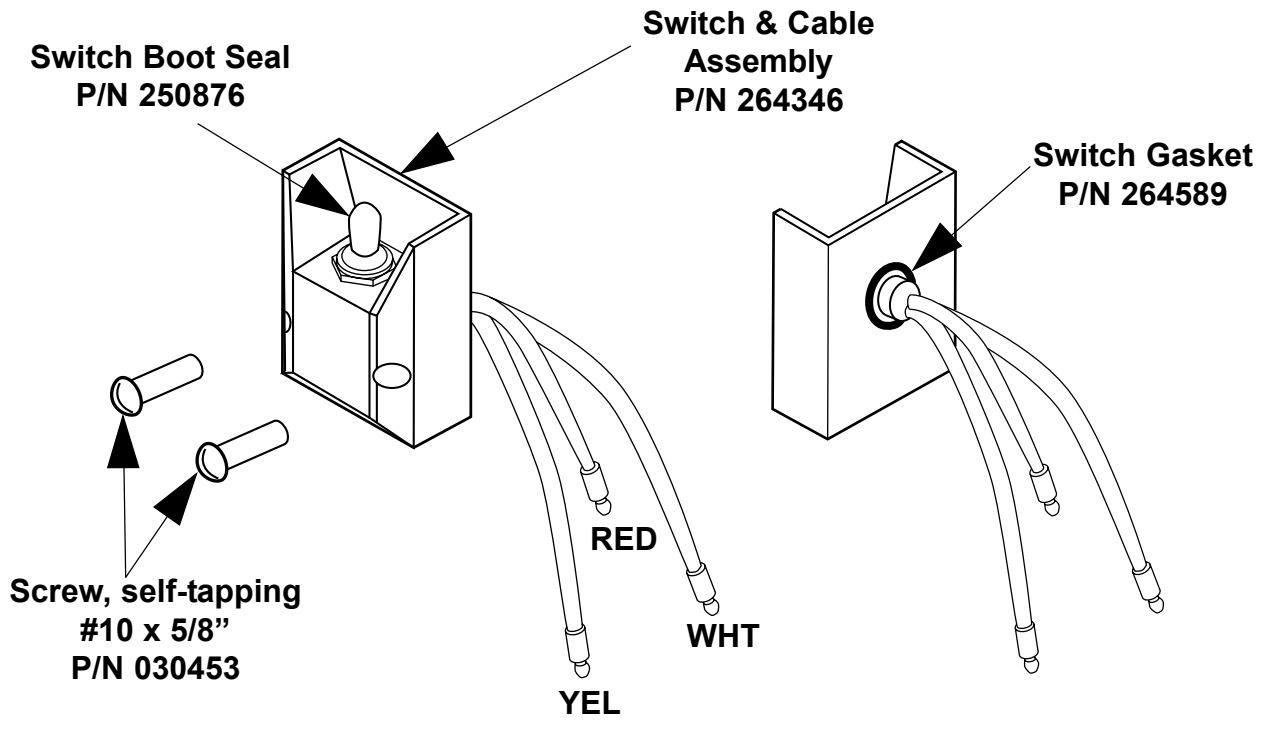

LOW VOLTAGE / THERMAL SWITCH (LVTS) (IF EQUIPPED ON LIFTGATE)

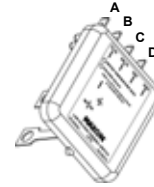
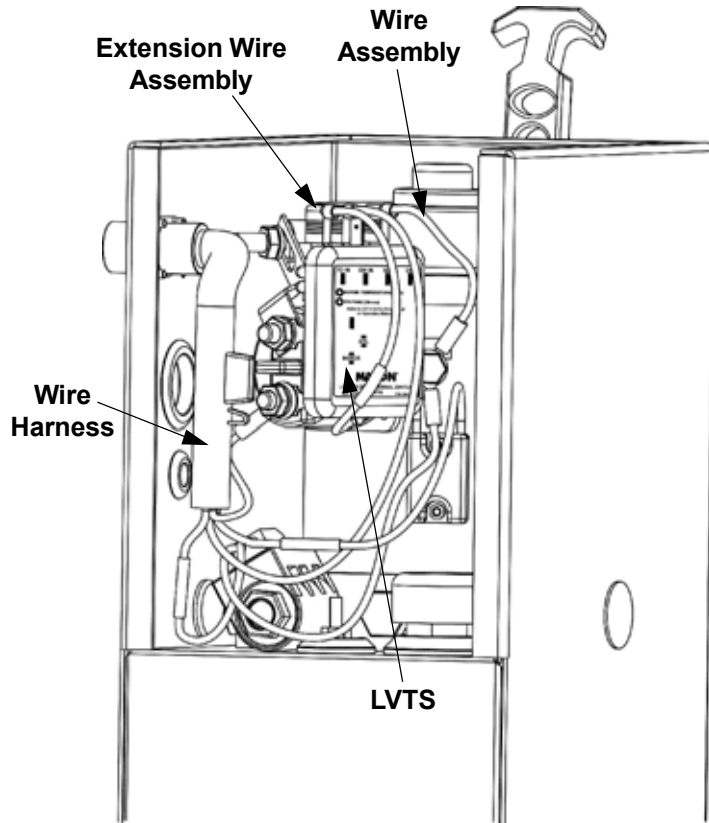

**Low Voltage/
Thermal Switch
(LVTS)
P/N 905197**

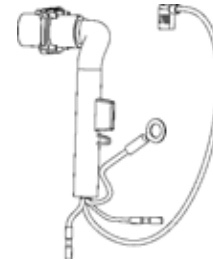

**Wire Harness
P/N 264548**



**Wire Assembly
P/N 264546**



**Extension Wire
Assembly
P/N 264755**

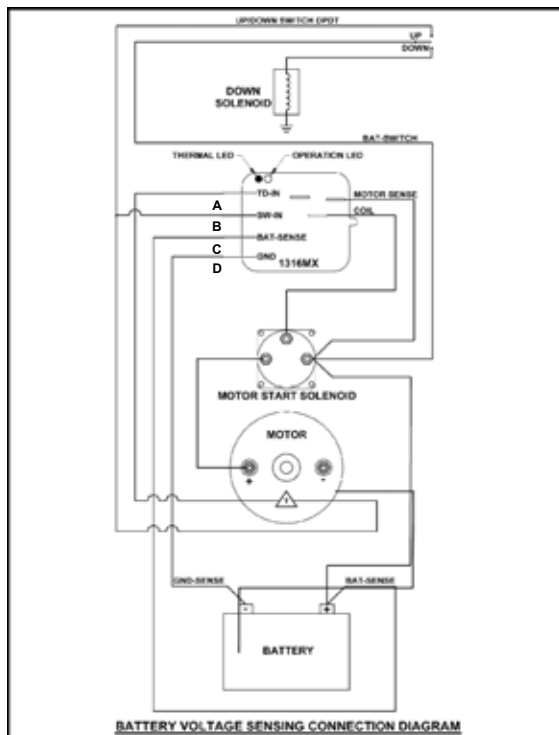

LOW VOLTAGE / THERMAL SWITCH (LVTS) (IF EQUIPPED ON LIFTGATE)

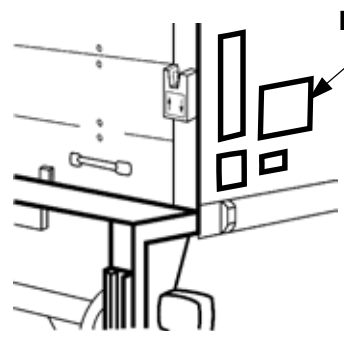

Instruction Decal
P/N 264776

Suggested Decal
Location

Decals should be read and completely understood before operating the unit. They should also be kept clean and readable at all times. If any decal becomes detached from the vehicle, or is defaced, it must be replaced. Free decal replacements are available from: MAXON Lift Corp., Parts Department.

Switch Decal
P/N 264775

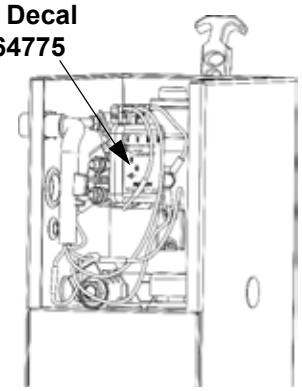

Instruction Decal
P/N 264776

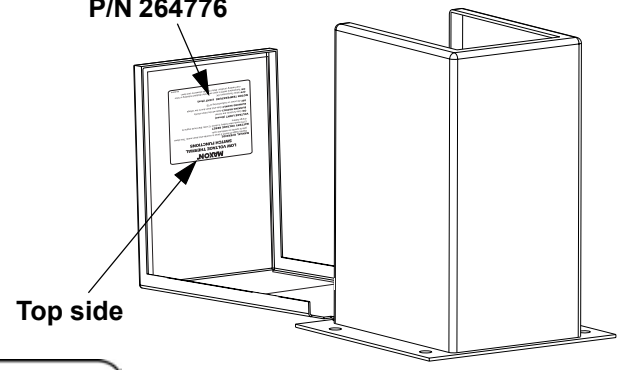

Top side

MAXON®

LOW VOLTAGE / THERMAL SWITCH (LVTS) INSTRUCTIONS

The LVTS system protection device, located inside the pump box on this liftgate, is designed to shutdown its operation when the motor temperature is too high or the battery voltage too low for reliable operation. Please follow the instructions below in the event this occurs.

VOLTAGE LIGHT (Green)

ON- Gate functions are normal

BLINKING RAPIDLY- Gate will shut down shortly

BLINKING SLOWLY- Gate shut down

OFF- No power or malfunctioning LVTS

MANUAL OVERRIDE
Rapidly toggle lift switch to the up position and back to the center position 5 times to override shut down mode. This allows gate to operate an additional cycle.

BATTERY VOLTAGE RESET
LVTS resets when battery is above 13 volts. Start truck engine to charge battery.

MOTOR TEMPERATURE LIGHT (Red)

OFF- Motor Temperature OK

ON- Motor is overheated and has shut down. Temperature switch will reset automatically and red light will go out when the motor has cooled down.

P/N 264776

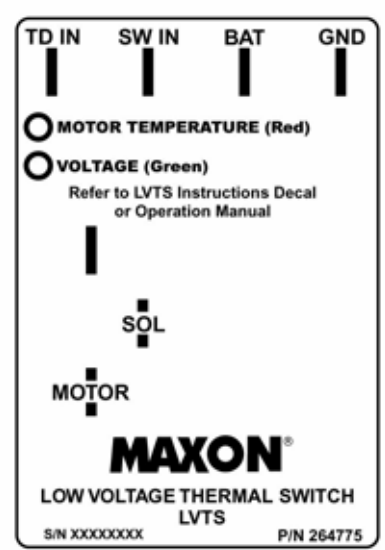

TROUBLESHOOTING

PLATFORM WILL NOT RAISE

1. Verify that power is being supplied to the Solenoid Terminal "A". Recharge the battery if less than 12 volts.
2. Fill Reservoir to within 1/2" below the top with the recommended hydraulic fluid.
3. Touch a jumper wire to terminals "A" & "C". If motor runs, check Switch, Switch connections, and White wire. Correct the connections or replace the Switch.
4. Touch heavy jumper cables to terminals "A" & "B".
 - a. If motor runs, replace the motor solenoid.
 - b. If motor does not run, repair or replace the pump motor.
5. Check for structural damage. Replace worn parts.
6. Check filter in the pump Reservoir. Replace if necessary.
7. Check for a broken motor-to-pump coupler. Replace if necessary. A worn pump is extremely noisy, and needs replacement.
8. If equipped with a Low Voltage Thermal Switch (LVTS), system could shut down if the motor temperature or battery voltage level reach an unacceptable level. Read decal P/N 264776 located near the switch to determine what steps need to be taken to correct the problem.

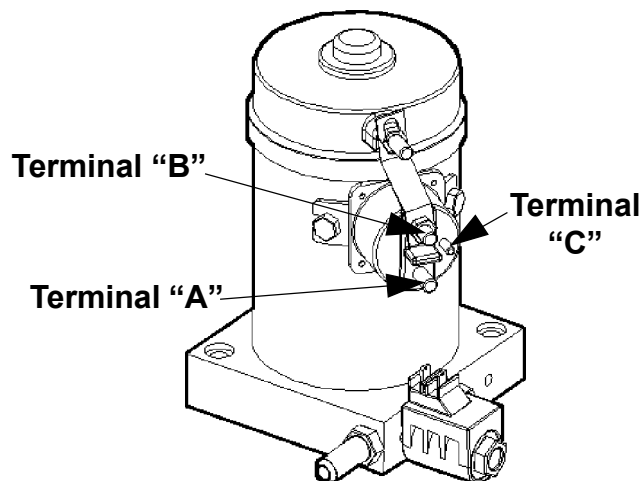

PLATFORM WILL NOT LOWER

1. Verify that power is being supplied to the Solenoid Terminal "A" (Ref. Fig. 1). Recharge the battery if less than 12 volts.

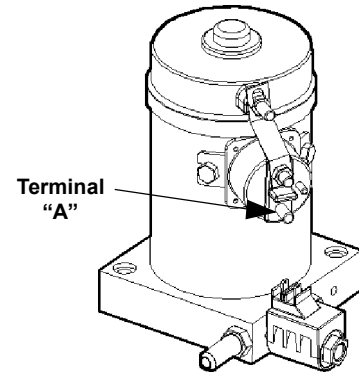

FIGURE 1

2. Check for structural damage or lack of lubrication. Replace worn parts.

3. Check Solenoid Valve for power by holding a screwdriver approximately 1/4" from the top nut of the Solenoid. Energize the unit. (See Fig. 2). A good solenoid will draw the screwdriver to the nut by a magnetic force. The Coil can be replaced by removing the Nut and Wires.

4. Check the Valve Stem by removing the Coil Assembly, (Item 1, Fig. 3). Unscrew the Valve Stem, (Item 2, Fig. 3), from the Pump. Push on the plunger that is located inside the Valve Stem by inserting a paper clip in the end. If the Plunger does not move freely approximately 1/8", replace the Valve Stem.

5. If equipped with a Low Voltage Thermal Switch (LVTS), system could shut down if the motor temperature or battery voltage level reach an unacceptable level. Read decal P/N 264776 located near the switch to determine what steps need to be taken to correct the problem.

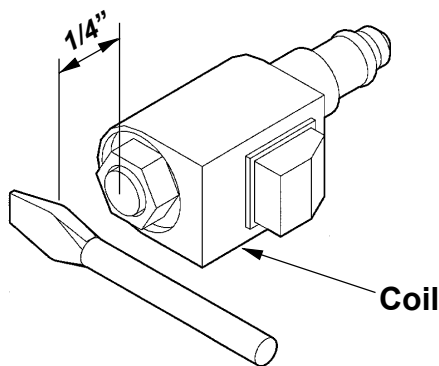

FIGURE 2

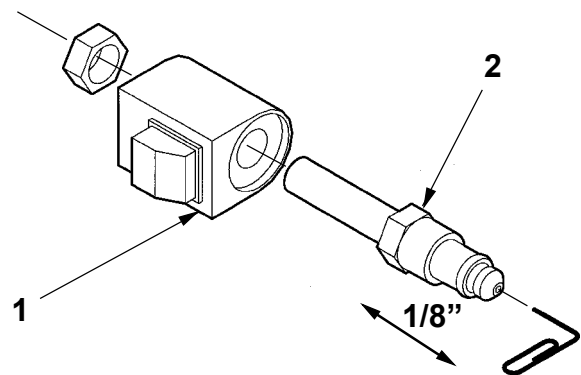

FIGURE 3

PLATFORM RAISES BUT LEAKS DOWN

MAXON[®]

11921 Slauson Ave. Santa Fe Springs, CA. 90670 (800) 227-4116 FAX (888) 771-7713

1. Check Solenoid Valves for electrical shorts by holding a screwdriver approximately 1/4" from the top nut of the Solenoid. (See Fig. 1). The solenoid should not draw the screwdriver to the nut with a magnetic force, unless the toggle switch is actuated. The Coil can be replaced by removing the Nut and Wires.

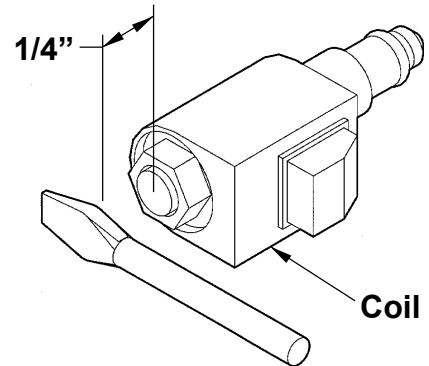

FIGURE 1

2. Check the Valve Stem by removing the Coil Assembly, (Item 1, Fig. 2). Unscrew the Valve Stem, (Item 2, Fig. 2), from the Pump. Push on the plunger that is located inside the Valve Stem by inserting a paper clip in the end. If the Plunger does not move freely approximately 1/8", replace the Valve Stem.

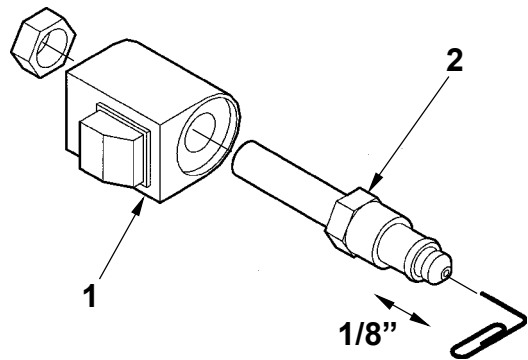

FIGURE 2

3. Check the Hydraulic Cylinder. With the Platform on the ground, remove the Breather Plug or Vent Line from the Vent Port of the Cylinder. Raise the Platform to be level with the bed. If hydraulic fluid streams from the Vent Port, the Piston Seals are worn. Replace the Seals. (See Fig. 3).

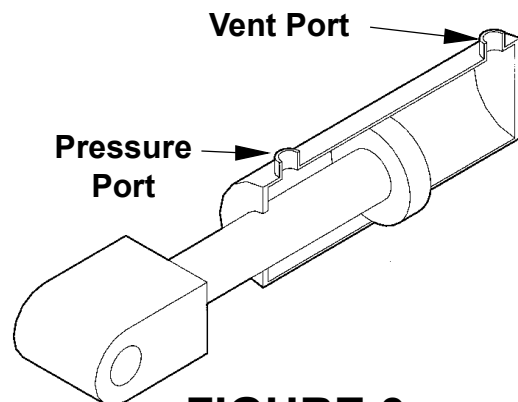

FIGURE 3

PLATFORM RAISES PARTIALLY AND STOPS

- 1.** Lower the opened Platform to the ground. Fill the Reservoir to within 1” from the top with the recommended Hydraulic Fluid.
- 2.** Verify that the Battery shows 12 volts or better under load from pump motor. The use of a voltage load tester is recommended.
- 3.** Check for Structural damage, or lack of lubrication. Replace worn parts.
- 4.** Check Filter in the Pump Reservoir. Replace if necessary.
- 5.** Check for a broken motor-to-pump coupler. Replace if necessary. A worn pump is extremely noisy, and needs replacement.
- 6.** If equipped with a Low Voltage Thermal Switch (LVTS), system could shut down if the motor temperature or battery voltage level reach an unacceptable level. Read decal P/N 264776 located near the switch to determine what steps need to be taken to correct the problem.

LIFTGATE WILL NOT LIFT RATED CAPACITY

1. Verify that the Battery shows 12 volts or better under load from pump motor. The use of a voltage load tester is recommended.
2. Check for Structural damage or lack of lubrication. Replace worn parts.
3. Check the Hydraulic Cylinder. With the Platform on the ground, remove the Breather Plug or Vent Line from the Vent Port of the Cylinder. Raise the Platform. If hydraulic fluid streams from the Vent Port, the Piston Seals are worn. Replace the Seals.
4. With Platform on the ground, remove the pressure hose and fitting from the Pump and replace it with a 0-3000 PSI Pressure Gauge. Hold the switch in the "UP" position. Adjust the Relief Valve on the side of the Pump until the gauge shows 2800 to 3000 PSI . **(See Fig. 2)**
5. If Pump cannot produce 2800-3000 PSI with a minimum of 12 Volts available, the Pump is worn and needs to be replaced.

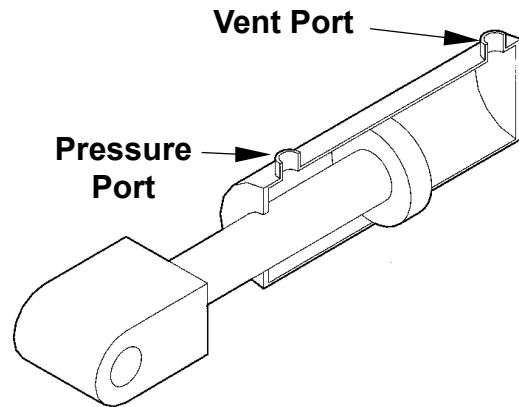

FIGURE 1

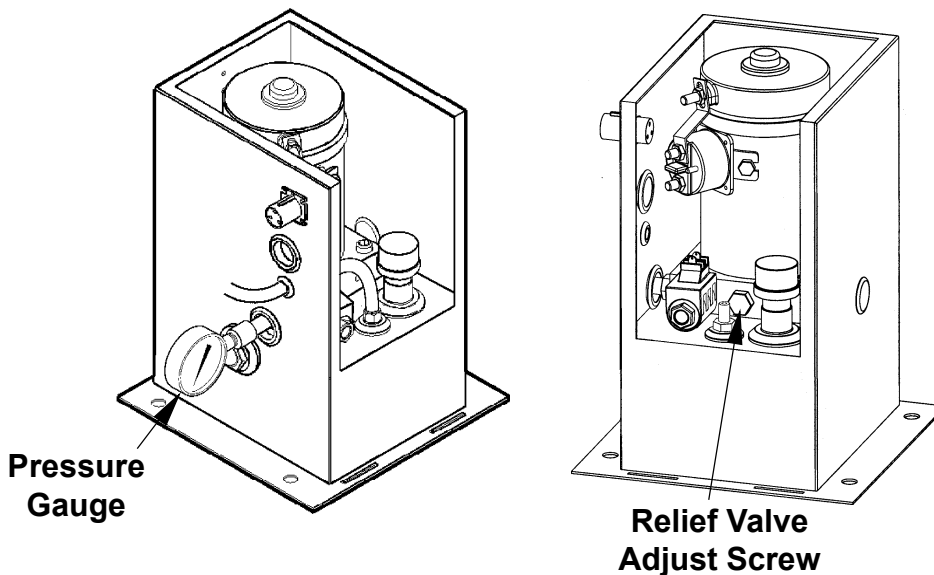

FIGURE 2

PLATFORM RAISES SLOWLY

1. Verify that power is being supplied to Terminal "A". Recharge the battery if less than 12 Volts registers on the Voltage Tester. **(See Fig. 1)**
2. Lower the opened Platform to the ground. Fill the Pump Reservoir to within 1" from the top with the recommended hydraulic fluid.
3. Verify the Pump Motor is grounded to the vehicle frame.
4. Check for leaking hoses and fittings. Tighten or replace as required.
5. Check for structural damage or lack of lubrication. Replace worn parts.

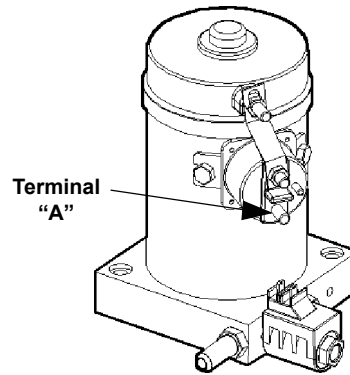

FIGURE 1

6. Check the Filter in the Pump Reservoir. Replace if necessary.
7. With Platform on the ground, remove the pressure hose and fitting from the Pump and replace it with a 0-3000 PSI Pressure Gauge. Hold the switch in the "UP" position. Adjust the Relief Valve on the side of the Pump until the gauge shows 2800 to 3000 PSI **(See Fig. 2).**
8. With the Platform on the ground, remove breather plug or vent line from vent port of cylinder. Raise the Platform to bed level. If hydraulic fluid streams from the Vent Port, the Piston Seals are worn. **(See Fig. 3)** Replace the Seals.

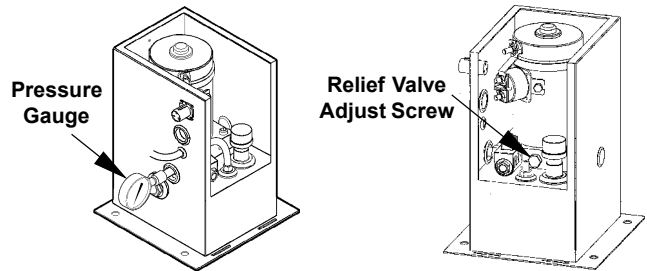

FIGURE 2

9. Check the Flow Control Valve. The arrow on the valve shows the direction of flow that is restricted, and Must point back to the Pump. **(See Fig. 3)**

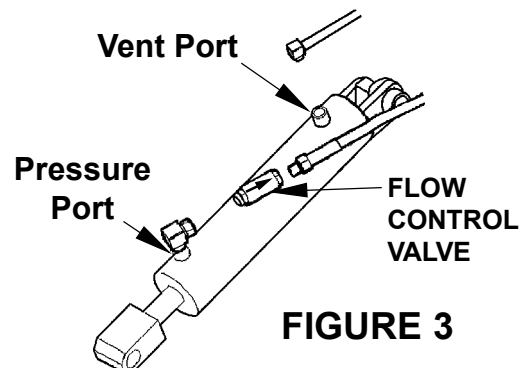

FIGURE 3

LIQUID SEALANT APPLICATION

1. Clean all threads with a soft brush and a suitable cleaning solvent.
2. Dry threads thoroughly with compressed air or shop towel.
3. Apply the Liquid Sealant (Compound PLS 2), to the external threads of the Male Connector.
4. Assemble the fitting and torque it to the prescribed value.
5. Check for leakage. If leakage exists, remove the fitting and return to Step # 1.
6. If fitting is loosened or removed, return to Step # 1.

