

INSTRUCTION, TRACTOR AND TRAILER CHARGE LINE KITS

TRAILER CHARGE LINE KITS

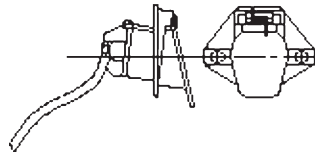

KIT (SINGLE-POLE)
(REFER TO SHEET 3)
P/N 280275-01

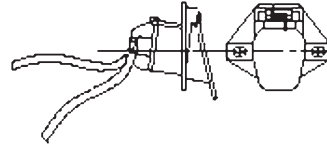

KIT (DUAL-POLE)
(REFER TO SHEET 5)
P/N 280275-02

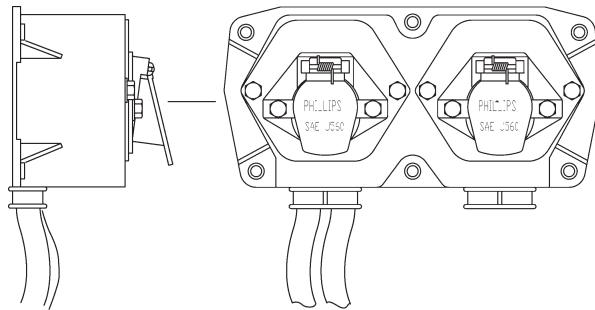

KIT (SINGLE-POLE OR DUAL-POLE)
(REFER TO SHEET 15)
P/N 280275-06



CABLE LUG,
2 GA COPPER, .038 ST
P/N 906497-03
QTY. 1 (-01 KIT)
QTY. 2 (-02, -06 KITS)

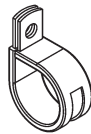

CLAMP,
#12 RUBBER LOOM
P/N 214675
QTY. 6 (-01, -02, -06 KITS)



PLASTIC TIE,
7" (50 LB)
P/N 205780
QTY. 6 (-01, -02, -06 KITS)

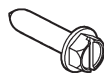

TAPPING SCREW,
5/16" X 1" ZINC
P/N 030435
QTY. 2 (-01, -02, KITS)
QTY. 6 (-06 KIT)

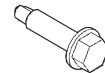

TAPPING SCREW,
#10 X 3/4" ZINC
P/N 030454
QTY. 6 (-01, -02, -06 KITS)

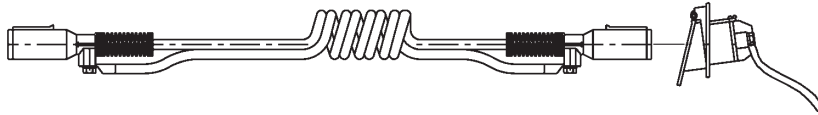
TRACTOR CHARGE LINE KITS

KIT (SINGLE-POLE)
(REFER TO SHEET 7)
P/N 280275-03

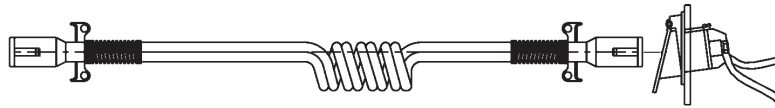

KIT (DUAL-POLE)
(REFER TO SHEET 10)
P/N 280275-04

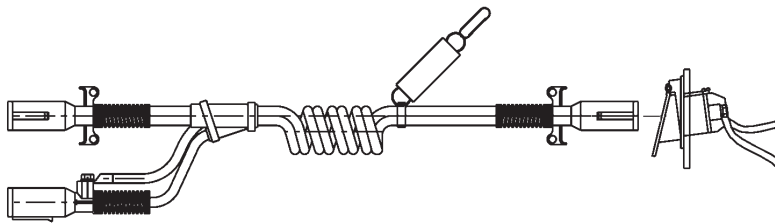

KIT (DUAL-POLE OR SINGLE-POLE ADAPTER)
(REFER TO SHEET 10)
P/N 280275-05



CABLE LUG,
2 GA COPPER, .038 ST
P/N 906497-03
QTY. 1 (-03 KIT)
QTY. 2 (-04, -05 KITS)

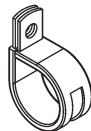

CLAMP,
#12 RUBBER LOOM
P/N 214675
QTY. 2 (-03, -04, -05 KITS)



PLASTIC TIE,
7" (50 LB)
P/N 205780
QTY. 2 (-03, -04, -05 KITS)



TAPPING SCREW,
5/16" X 1" ZINC
P/N 030435
QTY. 4 (-03, -04, -05 KITS)

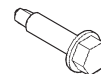

TAPPING SCREW,
#10 X 3/4" ZINC
P/N 030454
QTY. 2 (-03, -04, -05 KITS)

NOTE: Make sure the Liftgate power unit, all batteries on the vehicle for power unit, and taillights on Liftgate are connected correctly to a common ground.

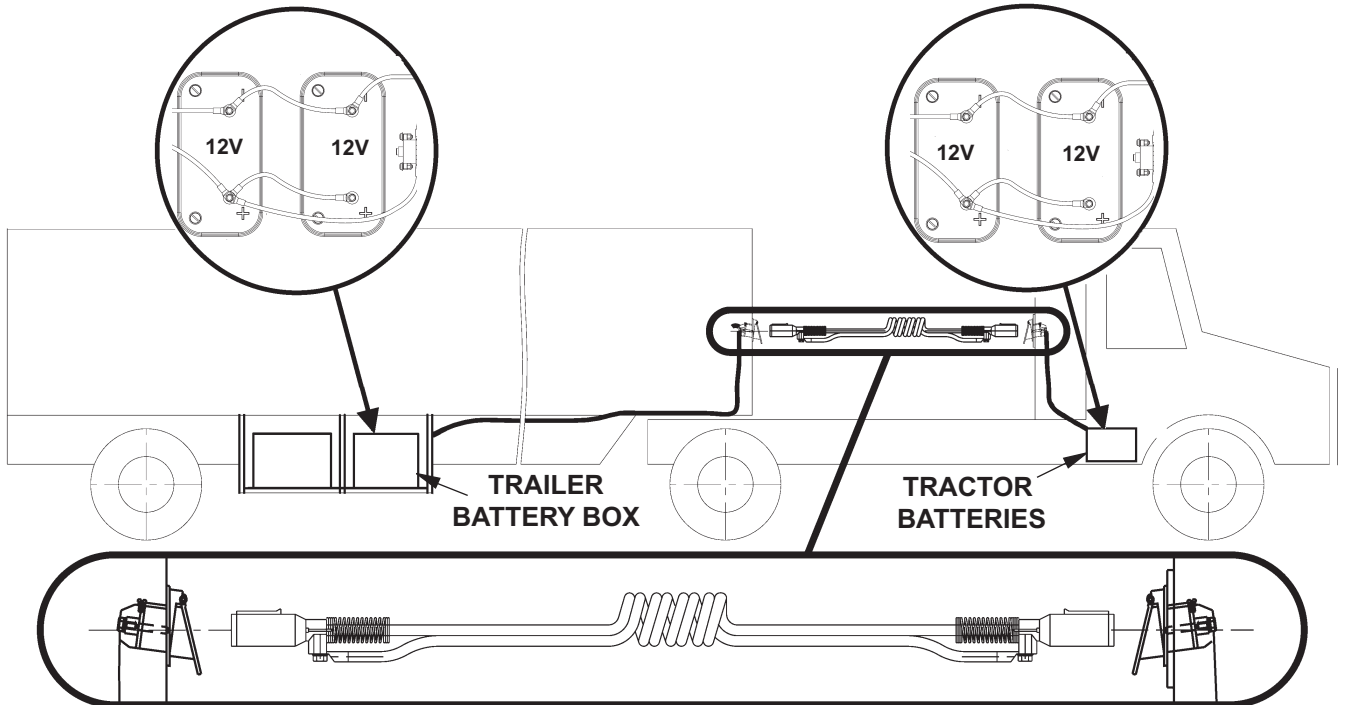

**SINGLE-POLE TRACTOR & TRAILER CHARGE LINE CONNECTIONS
(EXAMPLE 12 VOLT SYSTEM WITH PARALLEL-CONNECTED 12 VOLT BATTERIES)
FIG. 3-1**

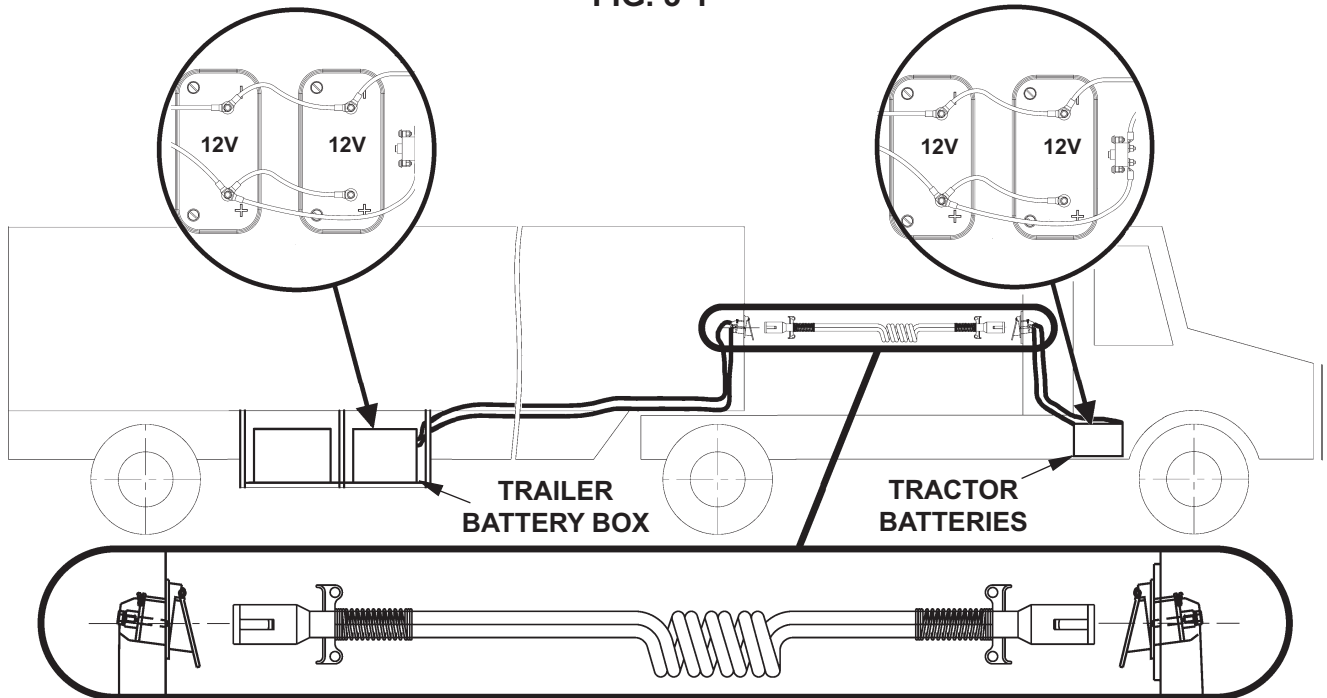

**DUAL-POLE TRACTOR & TRAILER CHARGE LINE CONNECTIONS
(EXAMPLE 12 VOLT SYSTEM WITH SERIES-CONNECTED 6 VOLT BATTERIES)
FIG. 3-2**

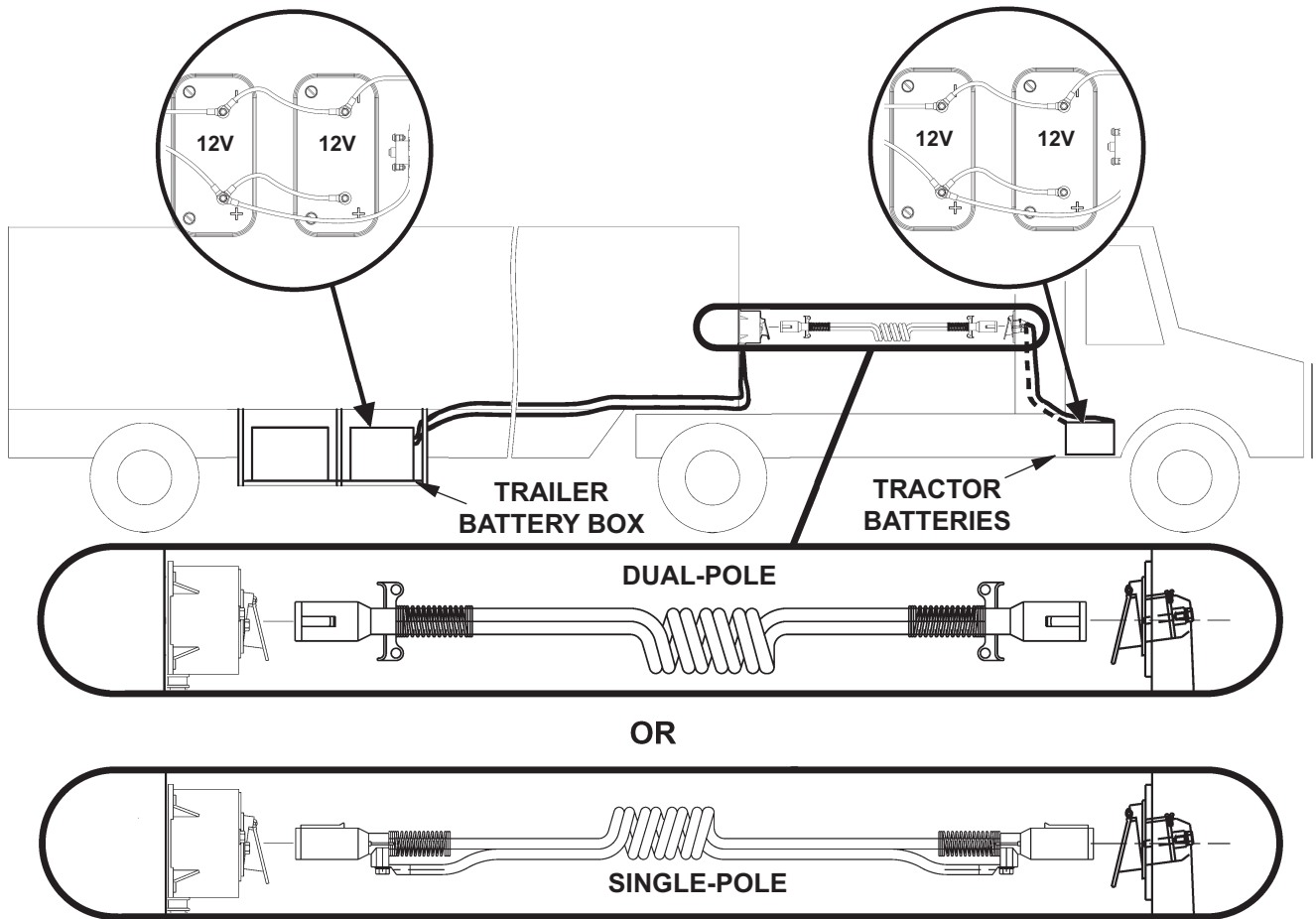

**SINGLE-POLE OR DUAL-POLE TRACTOR & TRAILER CHARGE LINE CONNECTIONS
(EXAMPLE 12 VOLT SYSTEM WITH PARALLEL-CONNECTED BATTERIES)**

FIG. 4-1

SINGLE-POLE TRAILER KIT INSTALLATION INSTRUCTIONS

WARNING

To prevent injury & damage while kit is installed, disconnect (-) battery cable from battery. Ensure charge line socket remains disconnected until installation is finished.

1. Select an area on lower front wall of trailer as close to center as possible. Mark and drill holes for single-pole socket (**FIG. 5-1**).

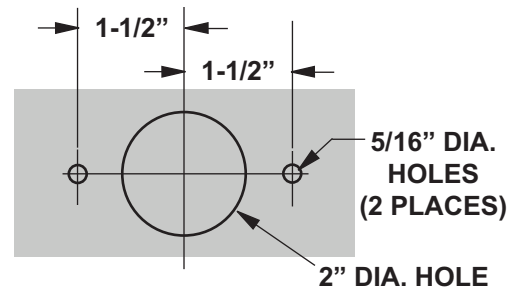

HOLE PATTERN FOR CHARGE LINE SOCKET
FIG. 5-1

2. Fasten the single pole socket (Kit item) to trailer wall with 5/16" x 1" long tapping screws (Kit item). (**See FIG. 5-2.**)

NOTE: Kit contains 60' long electrical cable. Before cutting cable to correct length, ensure cable is connected to charge line socket, routed to battery box, and correctly secured to vehicle. Cut the cable to final length at the battery box. Maintain enough slack on both cable ends, to prevent connections from being strained.

3. Bolt **RED (+)** cable to the socket (**FIG. 5-2**).

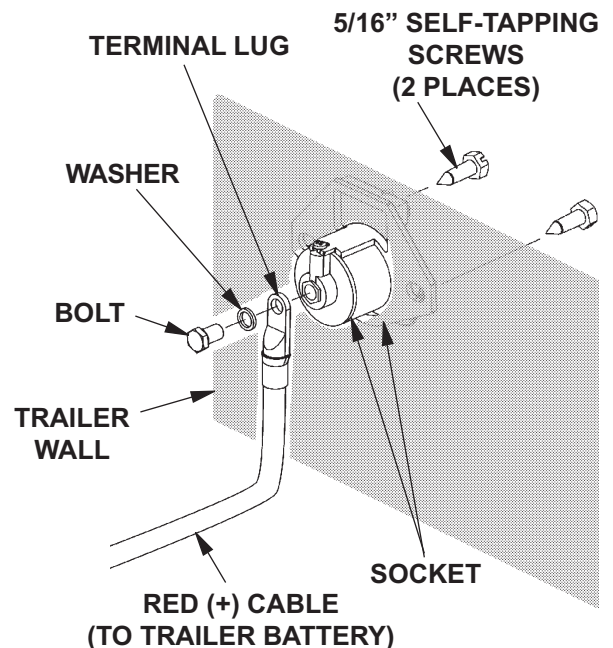

RED (+) CABLE CONNECTED TO SINGLE-POLE SOCKET
(VIEW FROM INSIDE TRAILER)
FIG. 5-2

⚠ CAUTION

Always route electrical wiring clear of moving parts, brake lines, and sharp edges. Avoid making sharp bends. Make sure that bends in the electrical wiring are 1" or more away from electrical connector. Attach securely. If drilling is necessary, first check behind the drilling surface so you do not damage any fuel lines, vent lines, brake lines or wires.

- Run **RED (+)** cable from single-pole socket to circuit breaker in battery box. Use clamps and self-tapping screws (Kit items) to secure cable to cross-members (**FIG. 6-1**).

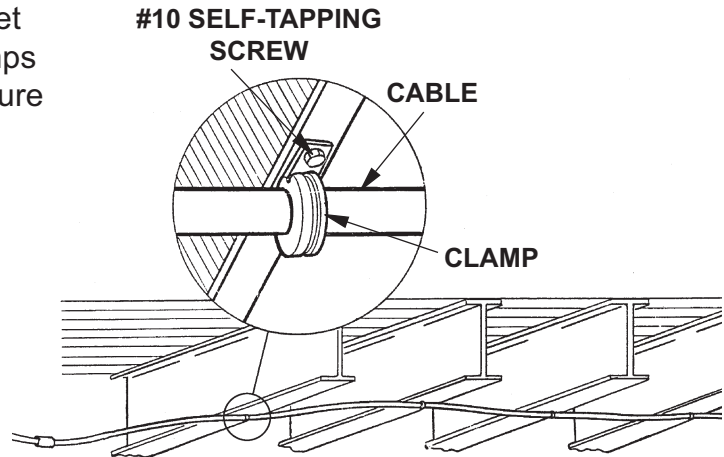

FUSED POWER (+) CABLE ROUTED & CLAMPED TO TRAILER CROSS MEMBERS
FIG. 6-1

NOTE: Example battery connections are shown for 12 volt system with parallel-connected 12 volt batteries.

- Prepare the wire end nearest the circuit breaker in the battery box as follows (**FIG. 6-2**). Cut cable to final length. Place heat-shrink tubing over cable. Crimp terminal lug. Then, shrink the tubing in place on the crimp portion of the terminal lug. Fasten terminal lug to un-connected terminal on circuit breaker.
- Reconnect (-) battery cable to battery (**FIG. 6-2**).

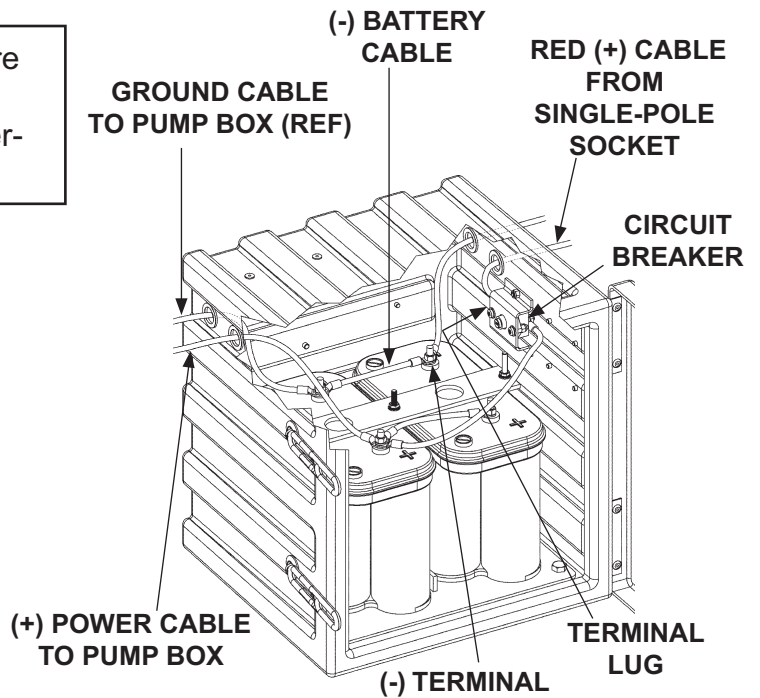

RED (+) CABLE CONNECTIONS IN BATTERY BOX
FIG. 6-2

DUAL-POLE TRAILER KIT INSTALLATION INSTRUCTIONS

WARNING

To prevent injury & damage while kit is installed, disconnect (-) battery cable from battery. Ensure charge line socket remains disconnected until installation is finished.

1. Select an area on lower front wall of trailer as close to center as possible. Mark and drill holes for single-pole socket (**FIG. 7-1**). Then fasten the single pole socket (Kit item) to trailer wall with 5/16" x 1" long tapping screws (Kit item).

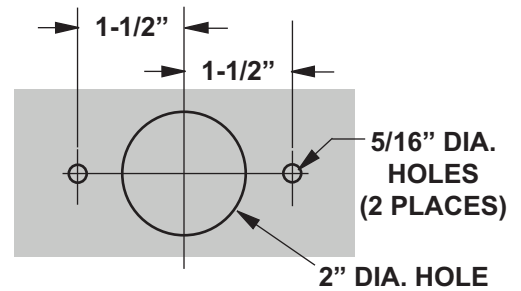

**HOLE PATTERN FOR
CHARGE LINE SOCKET
FIG. 7-1**

2. Fasten the single pole socket (Kit item) to trailer wall with 5/16" x 1" long tapping screws (Kit item). (See **FIG. 7-2**.)

NOTE: Kit contains two 60' long electrical cables. Before cutting each cable to correct length, ensure the (+) cable and (-) cable are connected to charge line sockets, routed to battery box, and correctly secured to vehicle. Cut each cable to final length at the battery box. Maintain enough slack on both cable ends, to prevent connections from being strained.

3. Bolt **RED (+)** cable and **BLACK (-)** cable to the socket (**FIG. 7-2**).

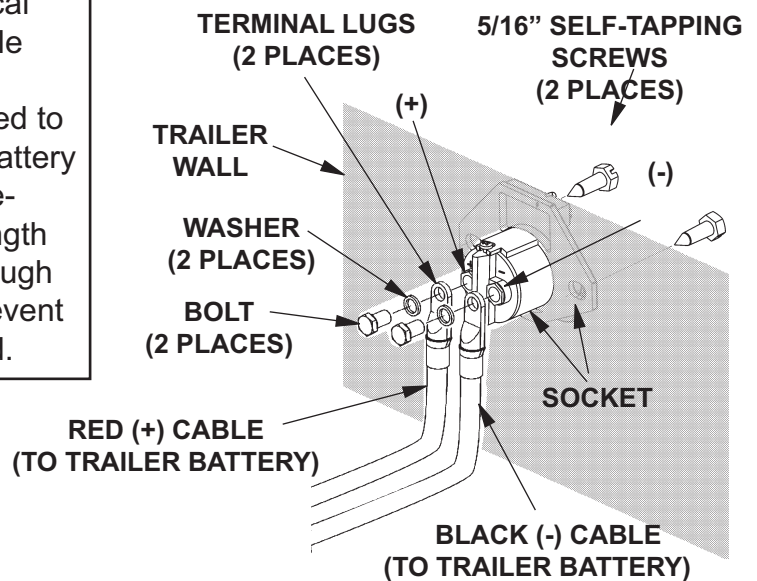

**RED (+) CABLE & BLACK (-) CABLE
CONNECTED TO DUAL-POLE SOCKET
(VIEW FROM INSIDE TRAILER)
FIG. 7-2**

! CAUTION

Always route electrical wiring clear of moving parts, brake lines, and sharp edges. Prevent (+) and (-) cables from touching. Avoid making sharp bends. Make sure that bends in the electrical wiring are 1" or more away from electrical connector. Attach securely. If drilling is necessary, first check behind the drilling surface so you do not damage any fuel lines, vent lines, brake lines or wires.

- Run cable from (+) standoff on the dual-pole socket to circuit breaker in battery box (FIG. 8-2). Then, run cable from (-) standoff on the dual-pole socket to battery (-) terminal in battery box. Use clamps to secure cables to cross-members (FIG. 8-1).

NOTE: Example battery connections are shown for 12 volt system with parallel-connected 12 volt batteries.

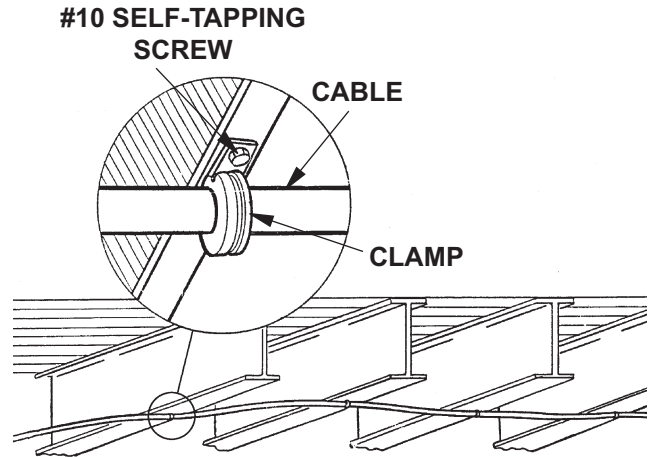

**CABLE ROUTED & CLAMPED TO TRAILER CROSS MEMBERS
FIG. 8-1**

- Prepare the wire end of the **RED (+)** cable nearest the circuit breaker in the battery box as follows (FIG. 8-2). Cut cable to final length. Place heat-shrink tubing over cable. Crimp terminal lug. Then, shrink the tubing in place on the crimp portion of the terminal lug. Fasten terminal lug to unconnected terminal on circuit breaker.
- Prepare the wire end of the **BLACK (-)** cable nearest the battery (-) terminal in the battery box (FIG. 8-2) as follows. Cut cable to final length. Place heat-shrink tubing over cable. Crimp terminal lug. Then, shrink the tubing in place on the crimp portion of the terminal lug. Connect terminal lug to battery (-) terminal.

NOTE: Make sure the Liftgate power unit, all batteries on the vehicle for power unit, and taillights on Liftgate are connected correctly to a common ground.

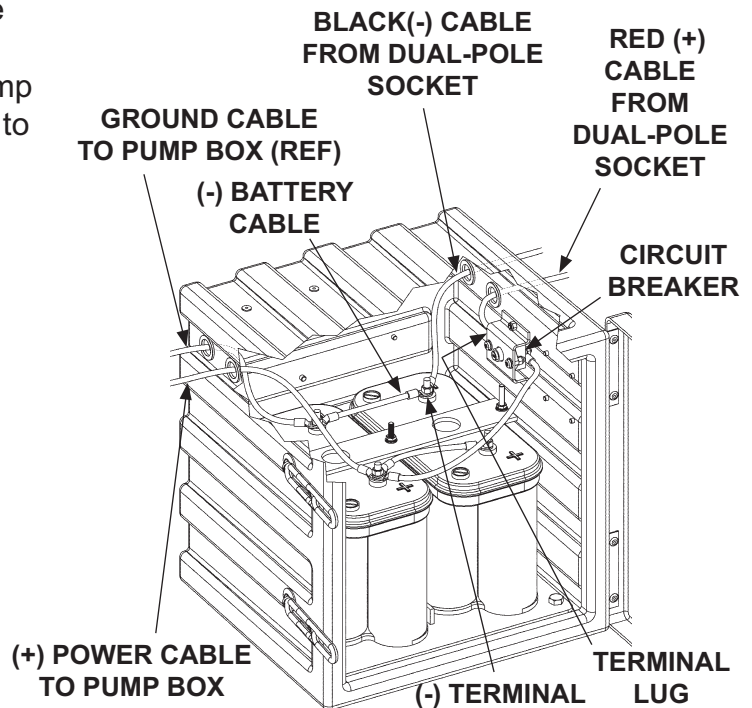

**(+) CHARGE LINE AND (-) GROUND LINE CONNECTIONS IN BATTERY BOX
FIG. 8-2**

- Reconnect (-) battery cable to battery (FIG. 8-2).

SINGLE-POLE TRACTOR KIT INSTALLATION

WARNING

To prevent injury & damage while kit is installed, disconnect (-) battery cable from tractor battery. Ensure charge lines remain disconnected until the tractor socket and trailer socket are correctly connected to batteries.

1. Select an area, near lower center, on the back wall of the tractor cab. Mark and drill holes for single-pole socket (**FIG. 9-1**). Then fasten the single pole socket (Kit item) and mounting plate (Kit item) to wall of the cab with 5/16" x 1" long tapping screws (Kit item).

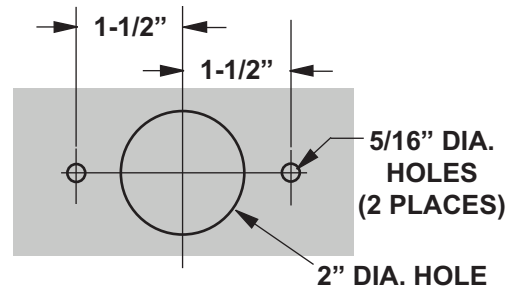

HOLE PATTERN FOR CHARGE LINE SOCKET
FIG. 9-1

2. Fasten the single pole socket (Kit item) and mounting plate (Kit item) to wall of the cab with 5/16" x 1" long tapping screws (Kit item) (**FIG. 9-2**).

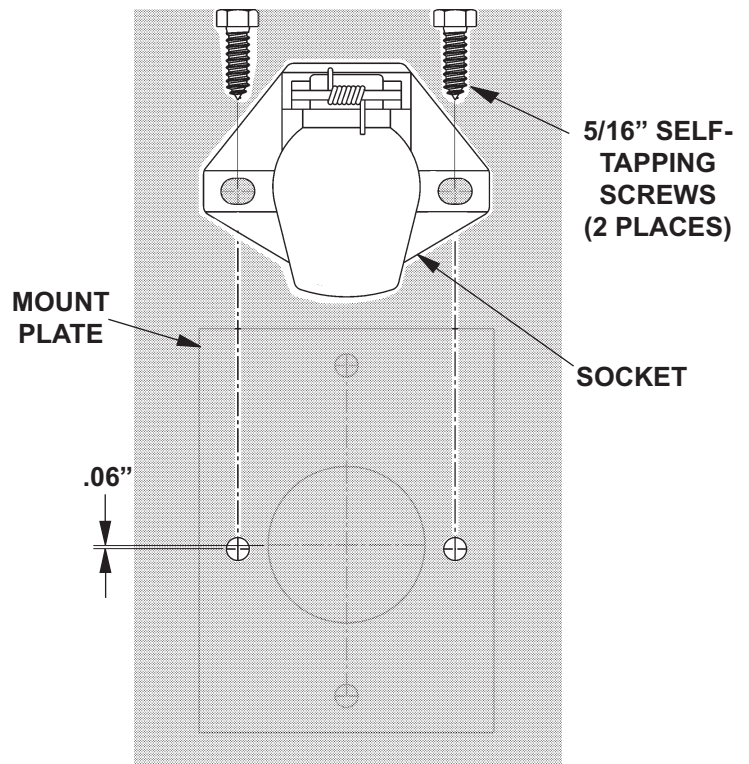

ATTACHING MOUNT PLATE & SINGLE-POLE SOCKET
(VIEW FROM OUTSIDE CAB)
FIG. 9-2

NOTE: Kit contains 18' long electrical cable. Before cutting cable to correct length, ensure cable is connected to charge line socket, fused end is routed to (+) terminal on the tractor batteries, and cable is correctly clamped to tractor. Cut the cable to final length at the battery box. Maintain enough slack on both cable ends, to prevent connections from being strained.

3. Fasten terminal lug on the **RED (+)** fused power cable to socket (**FIG. 10-1**).

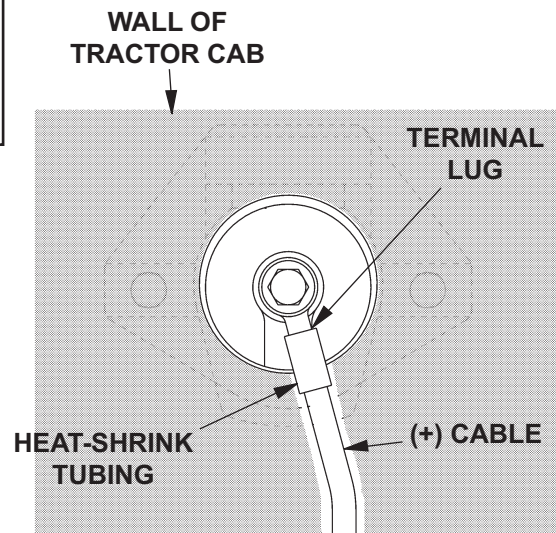

RED (+) CABLE CONNECTED TO SINGLE-POLE SOCKET (VIEW FROM INSIDE CAB)
FIG. 10-1

⚠ CAUTION

Always route electrical wiring clear of moving parts, brake lines, fuel lines, exhaust pipes and sharp edges. Avoid making sharp bends. Make sure that bends in the electrical wiring are 1" or more away from electrical connector. Attach securely. If drilling is necessary, first check behind the drilling surface so you do not damage any fuel lines, vent lines, brake lines, or wires.

4. Run **RED (+)** fused power cable from single-pole socket to tractor battery. Clamp cable to tractor as required (**FIG. 10-2**).

#10 SELF-TAPPING SCREW

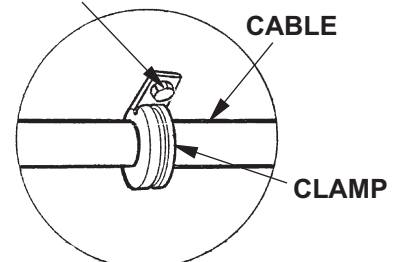

CABLE CLAMPED TO TRACTOR CAB
FIG. 10-2

5. Prepare the wire end of the **RED (+)** fused power cable, near the battery **(+)** terminal in the tractor battery **(FIG. 11-1)**, as follows. Cut cable to final length. Place heat-shrink tubing over cable. Crimp terminal lug. Then, shrink the tubing in place on the crimp portion of the terminal lug. Connect terminal lug to **(+)** terminal on the tractor battery. **(FIG. 11-1)**.

6. Reconnect **(-)** battery cable to tractor battery.

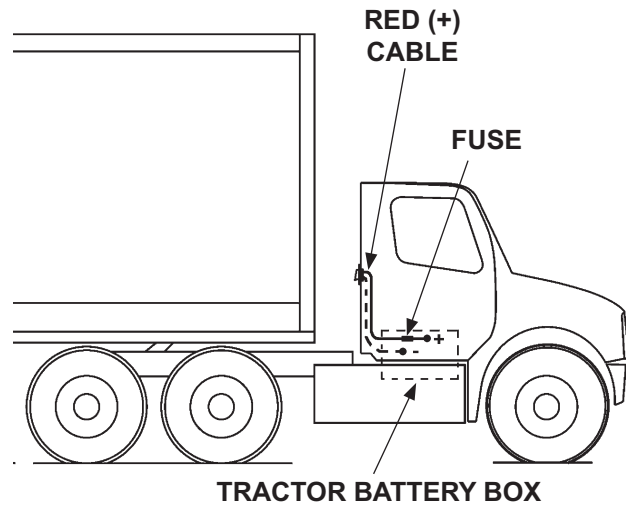

(+) CHARGE LINE CONNECTION TO CIRCUIT BREAKER
FIG. 11-1

NOTE: The tractor charge line has the same plug on both ends.

7. Plug charge line in the sockets on the tractor and trailer **(FIG. 11-2)**.

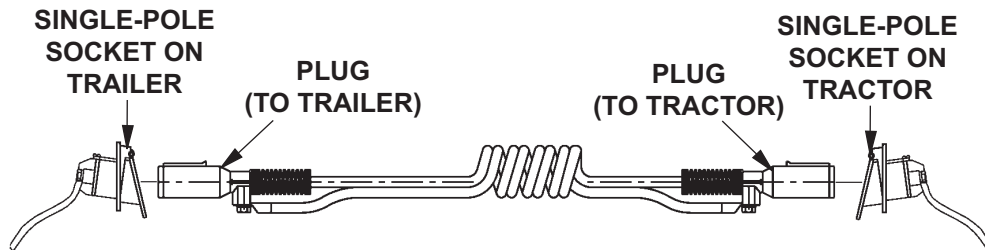

TRACTOR SINGLE-POLE CHARGE LINE CONNECTIONS
FIG. 11-2

DUAL-POLE TRACTOR KIT INSTALLATION

WARNING

To prevent injury & damage while kit is installed, disconnect (-) battery cable from battery. Ensure charge line socket remains disconnected until installation is finished.

1. Select an area, near lower center, on the back wall of the tractor cab. Mark and drill holes for single-pole socket (**FIG. 12-1**). Then fasten the single pole socket (Kit item) and mounting plate (Kit item) to wall of the cab with 5/16" x 1" long tapping screws (Kit item).

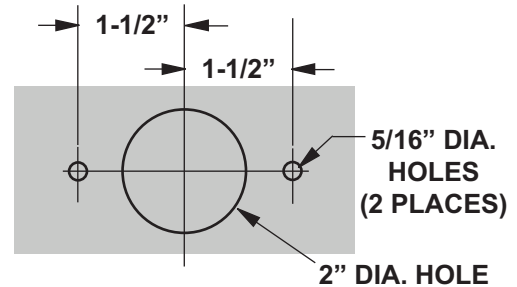

HOLE PATTERN FOR CHARGE LINE SOCKET
FIG. 12-1

2. Fasten the dual-pole socket (Kit item) and mounting plate (Kit item) to wall of the cab with 5/16" x 1" long tapping screws (Kit item) (**FIG. 12-2**).

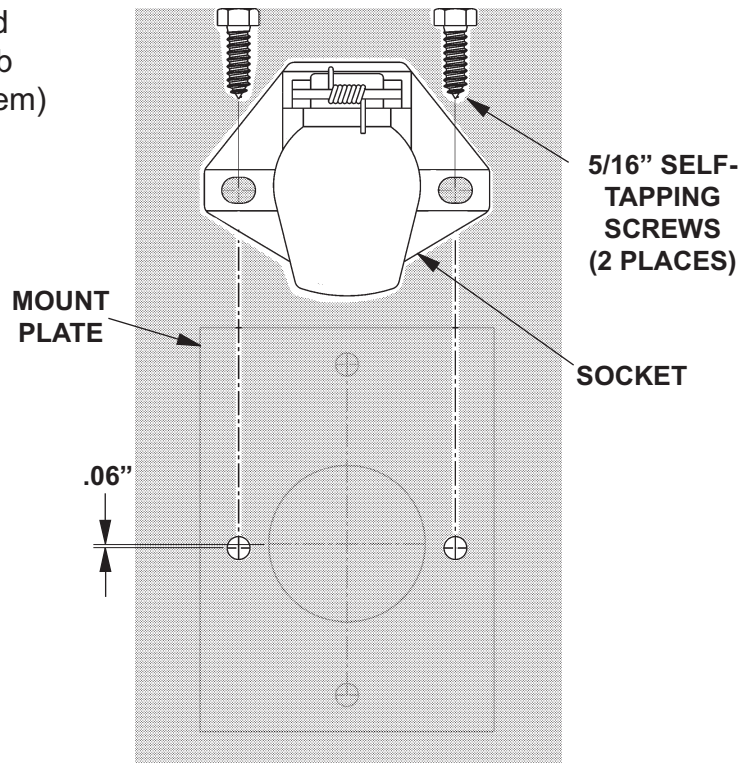

ATTACHING MOUNT PLATE & DUAL-POLE SOCKET
(VIEW FROM OUTSIDE CAB)
FIG. 12-2

NOTE: Kit contains 18' long electrical cable. Before cutting cable to correct length, ensure cable is connected to charge line socket, fused end is routed to (+) terminal on the tractor batteries, and cable is correctly clamped to tractor. Cut the cable to final length at the battery box. Maintain enough slack on both cable ends, to prevent connections from being strained.

3. Fasten terminal lug on the **RED (+)** fused power cable to socket (**FIG. 13-1**).
4. Fasten terminal lug on the **BLACK (-)** cable to socket (**FIG. 13-1**).

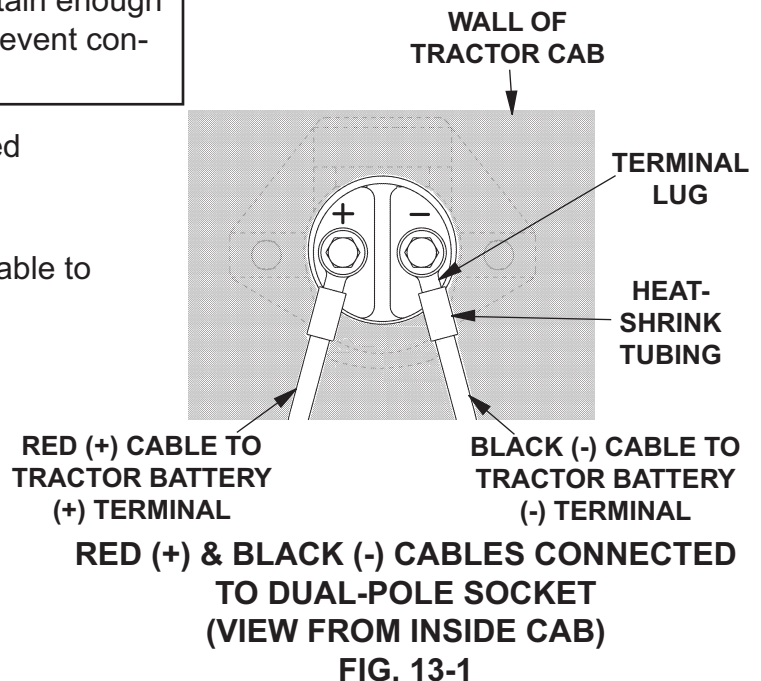

⚠ CAUTION

Always route electrical wiring clear of moving parts, brake lines, fuel lines, exhaust pipes and sharp edges. Avoid making sharp bends. Make sure that bends in the electrical wiring are 1" or more away from electrical connector. Attach securely. If drilling is necessary, first check behind the drilling surface so you do not damage any fuel lines, vent lines, brake lines, or wires.

5. Run **RED (+)** fused power cable from dual-pole socket to (+) terminal on the tractor battery. Clamp cable to tractor cab as required (**FIG. 13-2**).
6. Run **BLACK (-)** cable from dual-pole socket to the (-) terminal on the tractor battery. Clamp cable to tractor cab as required (**FIG. 13-2**).

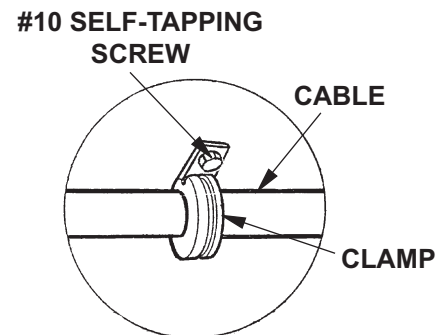

CABLE CLAMPED TO TRACTOR CAB

FIG. 13-2

7. Connect **RED (+)** fused power cable to **(+)** terminal on the tractor battery (**FIG. 14-1**).

8. Connect **BLACK (-)** cable to **(-)** terminal on the tractor battery (**FIG. 14-1**).

9. Reconnect **(-)** battery cable to tractor battery.

10. Plug the dual-pole charge line in the sockets on the tractor and trailer (**FIGS. 14-2 or 14-3**).

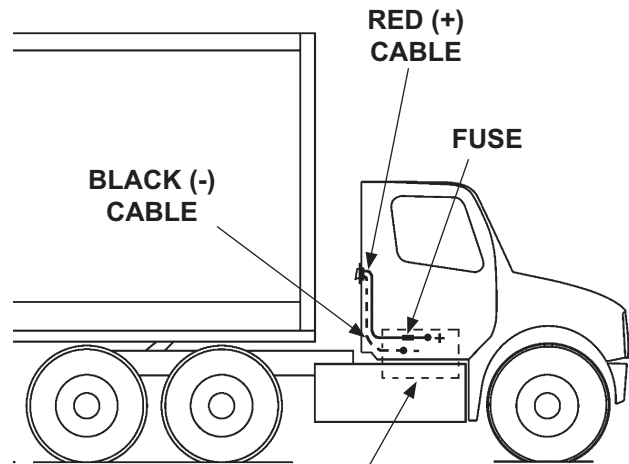

TRACTOR BATTERY BOX
(+) CHARGE LINE CONNECTION TO CIRCUIT BREAKER
FIG. 14-1

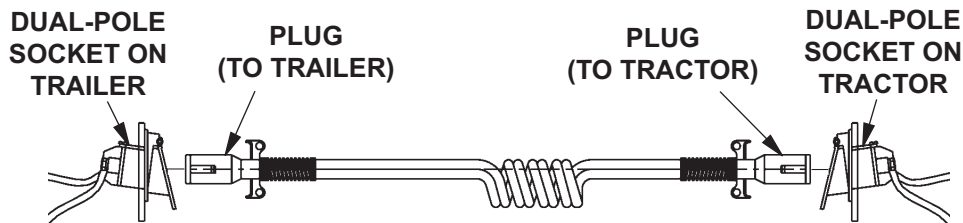

TRACTOR DUAL-POLE CHARGE LINE CONNECTIONS
FIG. 14-2

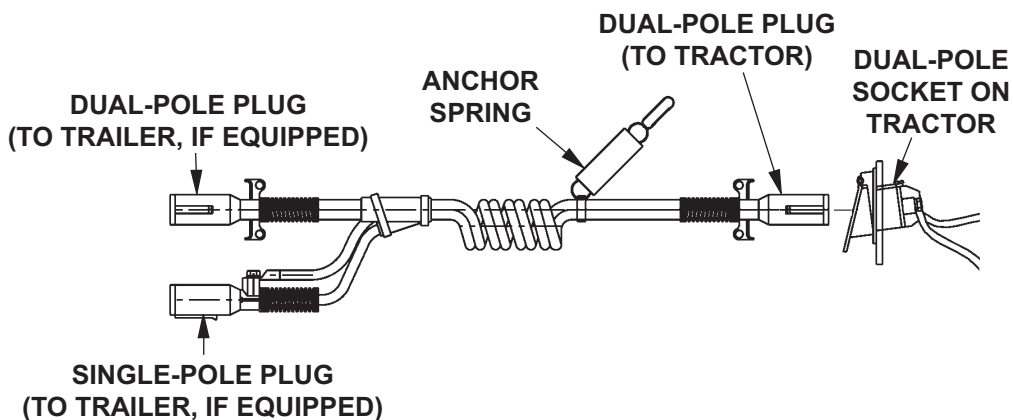

TRACTOR DUAL-POLE ADAPTER CHARGE LINE CONNECTIONS
FIG. 14-3

SINGLE-POLE OR DUAL-POLE TRAILER KIT INSTALLATION INSTRUCTIONS

WARNING

To prevent injury & damage while kit is installed, disconnect (-) battery cable from battery. Ensure charge line socket remains disconnected until installation is finished.

1. Select an area on lower front wall of trailer. Use the nose box as a template to mark and drill holes (**FIG. 15-1**).

2. Fasten the nose box (Kit item) to trailer wall with 5/16" x 1" long tapping screws (Kit item) (**FIG. 15-1**).

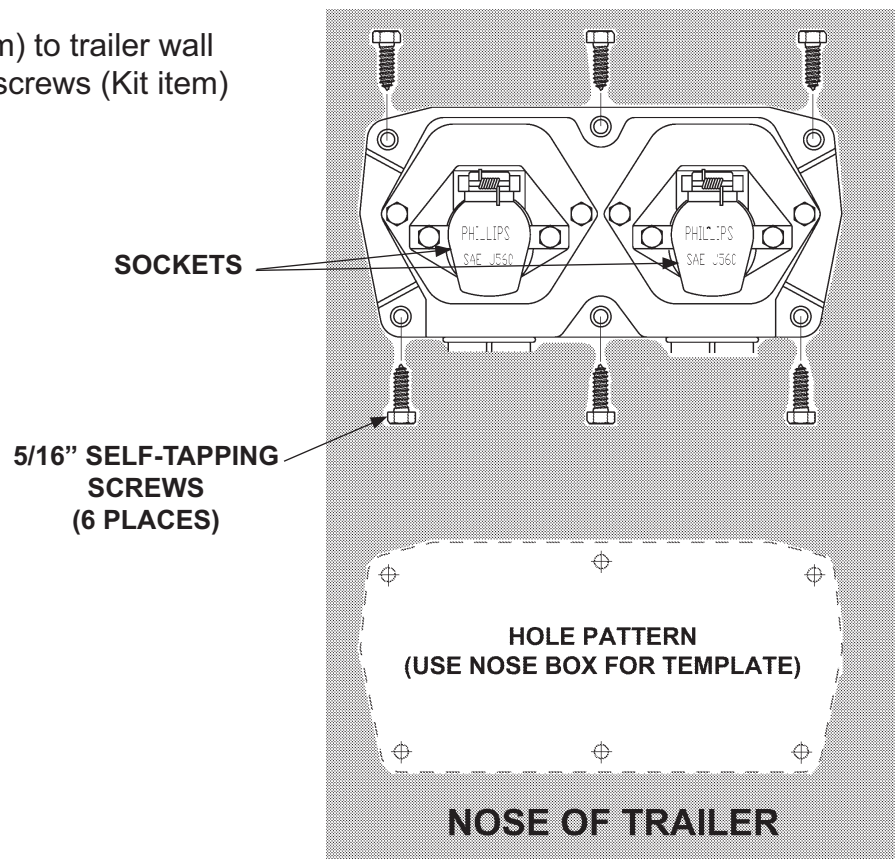

**MOUNTING
SINGLE-POLE OR DUAL-POLE SOCKET
(VIEW FROM OUTSIDE TRAILER)
FIG. 15-1**

⚠ CAUTION

Always route electrical wiring clear of moving parts, brake lines, and sharp edges. Prevent (+) and (-) cables from touching. Avoid making sharp bends. Make sure that bends in the electrical wiring are 1" or more away from electrical connector. Attach securely. If drilling is necessary, first check behind the drilling surface so you do not damage any fuel lines, vent lines, brake lines or wires.

NOTE: Kit contains 60' long electrical cables. Before cutting cables to correct length, ensure cables are routed to battery box and correctly secured to vehicle. Cut the cables to final length at the battery box. Maintain enough slack on both cable ends, to prevent connections from being strained.

NOTE: Example battery connections are shown for 12 volt system with parallel-connected 12 volt batteries.

- Run **RED (+)** cable from nose of the trailer to circuit breaker in battery box (**FIG. 16-2**). Then, run **BLACK (-)** cable from nose of the trailer to (-) battery terminal in battery box. Use clamps to secure cables to cross-members (**FIG. 16-1**).

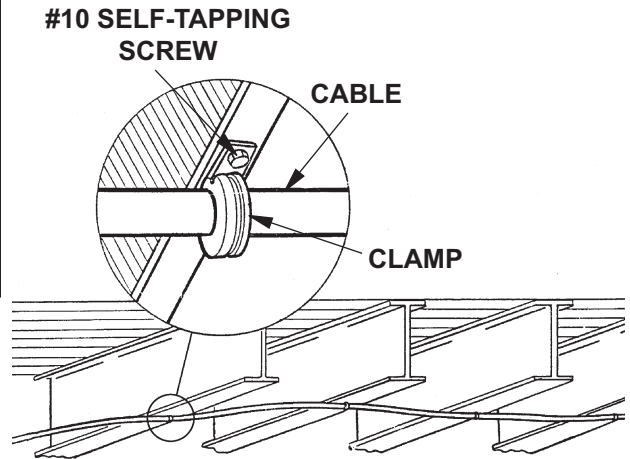

CABLE ROUTED & CLAMPED TO TRAILER CROSS MEMBERS
FIG. 16-1

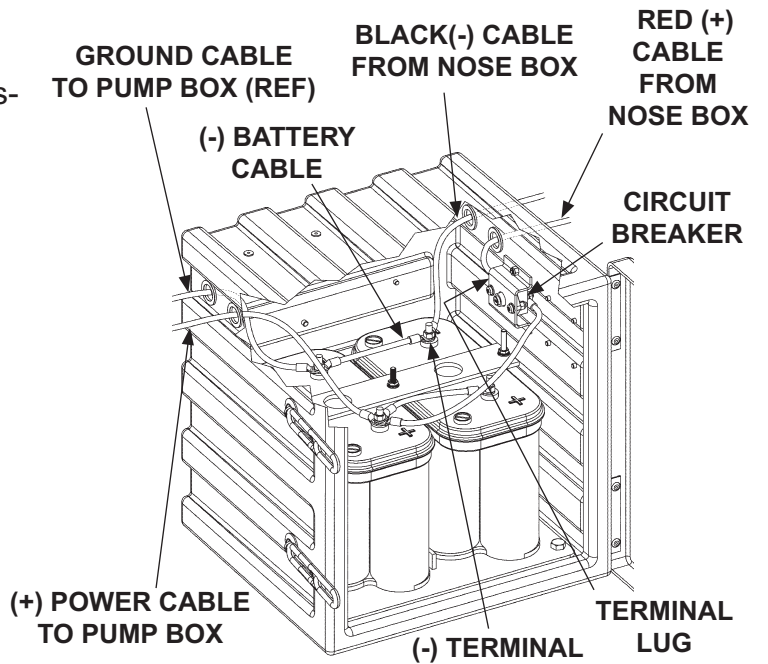

RED (+) CABLE & BLACK (-) CABLE CONNECTIONS IN BATTERY BOX
FIG. 16-2

4. Prepare the wire end of the **RED (+)** cable nearest the circuit breaker in the battery box as follows (**FIG. 17-1**). Cut cable to final length. Place heat-shrink tubing over cable. Crimp terminal lug. Then, shrink the tubing in place on the crimp portion of the terminal lug. Fasten terminal lug to unconnected terminal on circuit breaker.

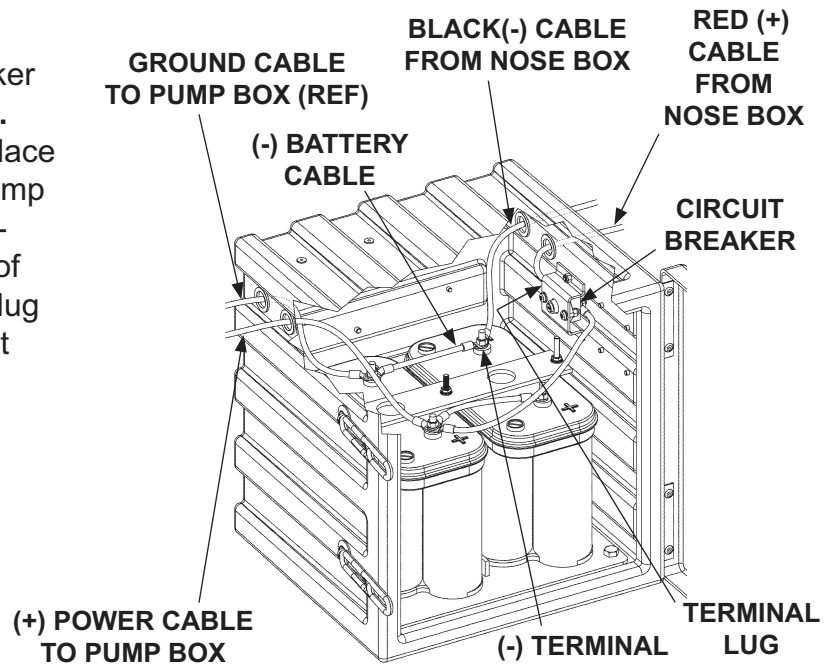

(+) CHARGE LINE AND (-) GROUND LINE CONNECTIONS IN BATTERY BOX
FIG. 17-1

5. Prepare the wire end of the **BLACK (-)** cable nearest the battery **(-)** terminal in the battery box (**FIG. 17-1**) as follows. Cut cable to final length. Place heat-shrink tubing over cable. Crimp cable lug. Then, shrink the tubing in place on the crimp portion of the cable lug. Connect **BLACK (-)** cable to battery **(-)** terminal.

NOTE: Make sure the Liftgate power unit, all batteries on the vehicle for power unit, and taillights on Liftgate are connected correctly to a common ground.

6. Reconnect **(-)** battery cable to battery (**FIG. 17-1**).