

INSTRUCTION, DUAL STEP INSTALLATION KIT

**KIT (GPTLR-44 & GPTLR-55)
P/N 281311-01**

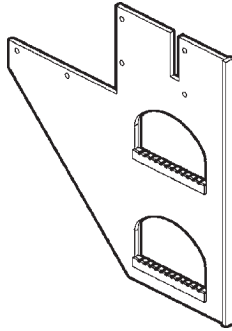

**DUAL STEP, LH
P/N 281299-01
QTY. 1**

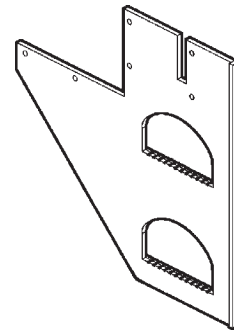

**DUAL STEP, RH
P/N 281299-02
QTY. 1**



**HEX HEAD CAP SCREW
1/2"-13 X 1-1/2" LG.
P/N 900035-3
QTY. 12**



**FLANGE LOCK NUT,
1/2"-13
P/N 901023
QTY. 12**

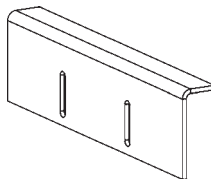

**STEP HOLDER ANGLE
P/N 281099-01
QTY. 2**

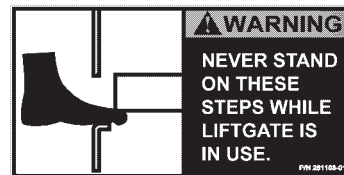

**CAUTION DECAL, DUAL STEP
(APPLIED AT FACTORY)
P/N 281103-01
QTY. 2**

**KIT (GPTLR-44 & GPTLR-55, DUAL STEP, GALVANIZED)
P/N 281311-01G**

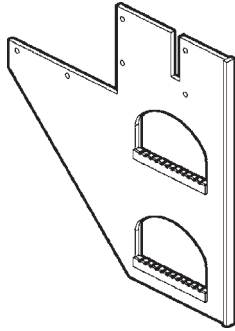

**DUAL STEP, LH
P/N 281299-01G
QTY. 1**

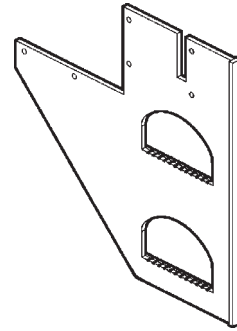

**DUAL STEP, RH
P/N 281299-02G
QTY. 1**



**HEX HEAD CAP SCREW
1/2"-13 X 1-1/2" LG.
P/N 900035-3
QTY. 12**

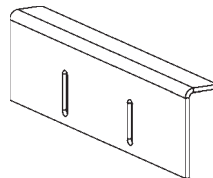

**STEP HOLDER ANGLE
P/N 281099-01G
QTY. 2**



**FLANGE LOCK NUT,
1/2"-13
P/N 901023
QTY. 12**

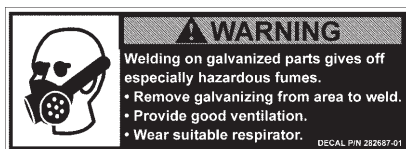

**GALVANIZED WARNING DECAL
(APPLIED AT FACTORY)
P/N 282687-01
QTY. 1**



**CAUTION DECAL, DUAL STEP
(APPLIED AT FACTORY)
P/N 281103-01
QTY. 2**

**KIT (GPTLR-25 & GPTLR-33)
P/N 281312-01**

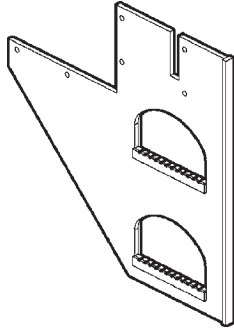

**DUAL STEP, LH
P/N 281313-01
QTY. 1**

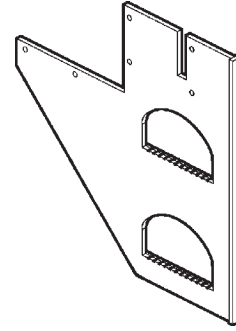

**DUAL STEP, RH
P/N 281313-02
QTY. 1**



**HEX HEAD CAP SCREW
1/2"-13 X 1-1/2" LG.
P/N 900035-3
QTY. 12**



**FLANGE LOCK NUT,
1/2"-13
P/N 901023
QTY. 12**

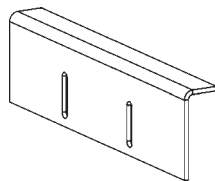

**STEP HOLDER ANGLE
P/N 281099-01
QTY. 2**

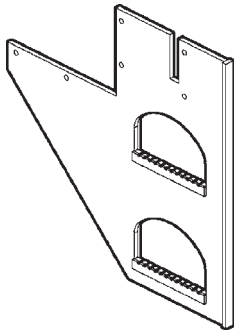
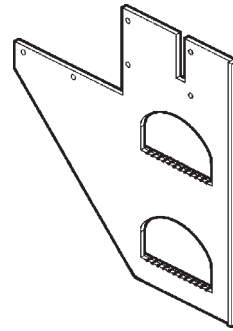
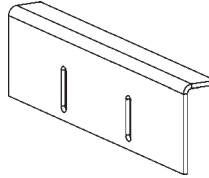
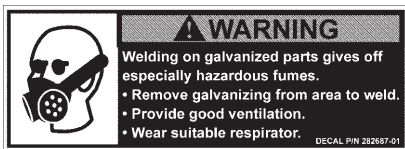

**CAUTION DECAL, DUAL STEP
(APPLIED AT FACTORY)
P/N 281103-01
QTY. 2**

**KIT (GPTLR-25 & GPTLR-33, DUAL STEP, GALVANIZED)
P/N 281312-01G****DUAL STEP, LH
P/N 281313-01G
QTY. 1****DUAL STEP, RH
P/N 281313-02G
QTY. 1****HEX HEAD CAP SCREW
1/2"-13 X 1-1/2" LG.
P/N 900035-3
QTY. 12****STEP HOLDER ANGLE
P/N 281099-01G
QTY. 2****FLANGE LOCK NUT,
1/2"-13
P/N 901023
QTY. 12****GALVANIZED WARNING DECAL
(APPLIED AT FACTORY)
P/N 282687-01
QTY. 1****CAUTION DECAL, DUAL STEP
(APPLIED AT FACTORY)
P/N 281103-01
QTY. 2**

**KIT (GPTLR-25 & GPTLR-33, STREETSIDE STEPS)
P/N 281312-02**

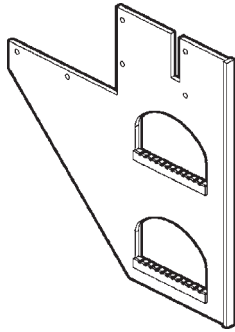

**DUAL STEP, LH
P/N 281313-01
QTY. 1**

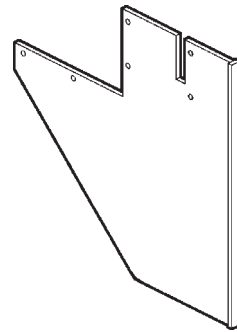

**SIDE PLATE, RH (NO STEPS)
P/N 281313-04
QTY. 1**



**HEX HEAD CAP SCREW
1/2"-13 X 1-1/2" LG.
P/N 900035-3
QTY. 12**



**FLANGE LOCK NUT,
1/2"-13
P/N 901023
QTY. 12**

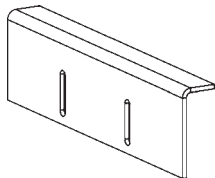

**STEP HOLDER ANGLE
P/N 281099-01
QTY. 2**

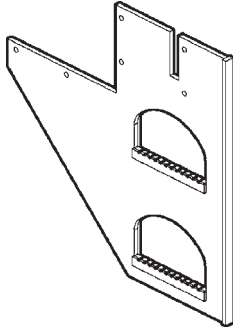

**CAUTION DECAL, DUAL STEP
(APPLIED AT FACTORY)
P/N 281103-01
QTY. 1**

**KIT (GPTLR-25 & GPTLR-33, STREETSIDE STEPS, GALVANIZED)
P/N 281312-02G**

DUAL STEP, LH
P/N 281313-01G
QTY. 1

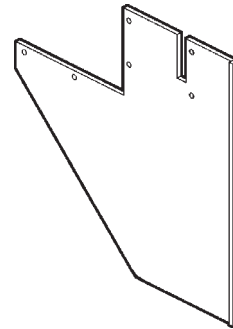

SIDE PLATE, RH (NO STEPS)
P/N 281313-04G
QTY. 1



HEX HEAD CAP SCREW
1/2"-13 X 1-1/2" LG.
P/N 900035-3
QTY. 12

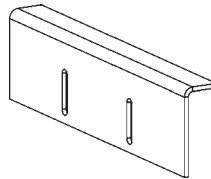

STEP HOLDER ANGLE
P/N 281099-01G
QTY. 2



FLANGE LOCK NUT,
1/2"-13
P/N 901023
QTY. 12

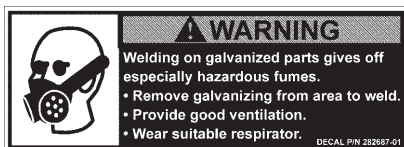

GALVANIZED WARNING DECAL
(APPLIED AT FACTORY)
P/N 282687-01
QTY. 1



CAUTION DECAL, DUAL STEP
(APPLIED AT FACTORY)
P/N 281103-01
QTY. 1

**KIT (GPTLR-25 & GPTLR-33, CURBSIDE STEPS)
P/N 281312-03**

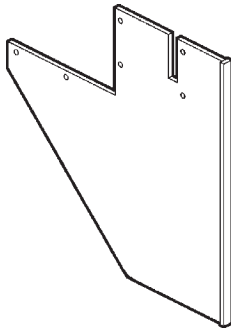

**SIDE PLATE, LH (NO STEPS)
P/N 281313-03
QTY. 1**

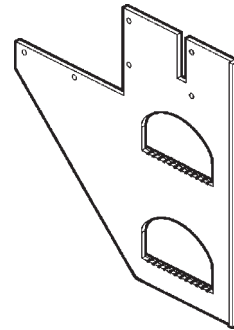

**DUAL STEP, RH
P/N 281313-02
QTY. 1**



**HEX HEAD CAP SCREW
1/2"-13 X 1-1/2" LG.
P/N 900035-3
QTY. 12**



**FLANGE LOCK NUT,
1/2"-13
P/N 901023
QTY. 12**

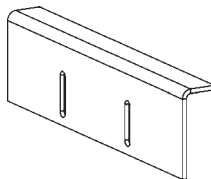

**STEP HOLDER ANGLE
P/N 281099-01
QTY. 2**

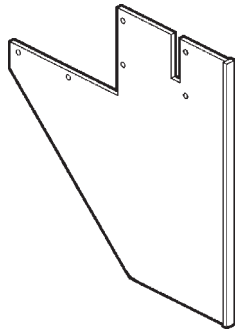

**CAUTION DECAL, DUAL STEP
(APPLIED AT FACTORY)
P/N 281103-01
QTY. 1**

**KIT (GPTLR-25 & GPTLR-33, CURBSIDE STEPS, GALVANIZED)
P/N 281312-03G**

SIDE PLATE, LH (NO STEPS)
P/N 281313-03G
QTY. 1

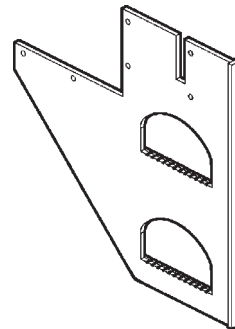

DUAL STEP, RH
P/N 281313-02G
QTY. 1



HEX HEAD CAP SCREW
1/2"-13 X 1-1/2" LG.
P/N 900035-3
QTY. 12

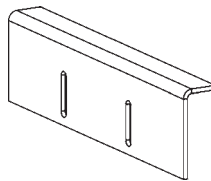

STEP HOLDER ANGLE
P/N 281099-01G
QTY. 2



FLANGE LOCK NUT,
1/2"-13
P/N 901023
QTY. 12

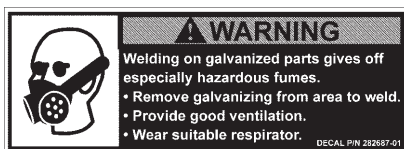

**GALVANIZED WARNING DECAL
(APPLIED AT FACTORY)**
P/N 282687-01
QTY. 1



**CAUTION DECAL, DUAL STEP
(APPLIED AT FACTORY)**
P/N 281103-01
QTY. 1

1. Lower platform to ground level (**FIG. 9-1**).

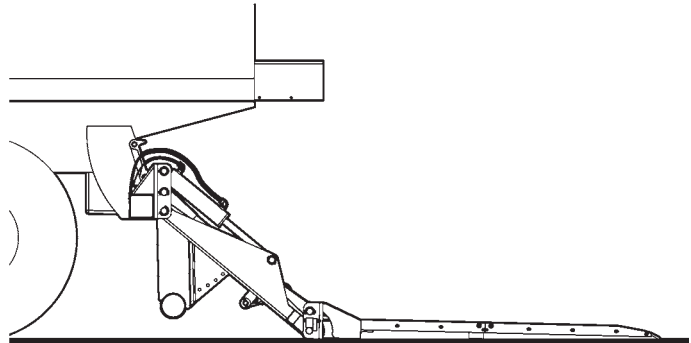

**PLATFORM AT GROUND LEVEL
(LH SIDE SHOWN)
FIG. 9-1**

2. Position the LH dual step on LH side of the extension plate. Bolt it to the extension plate with 4 bolts and lock nuts (**FIG. 9-2**).

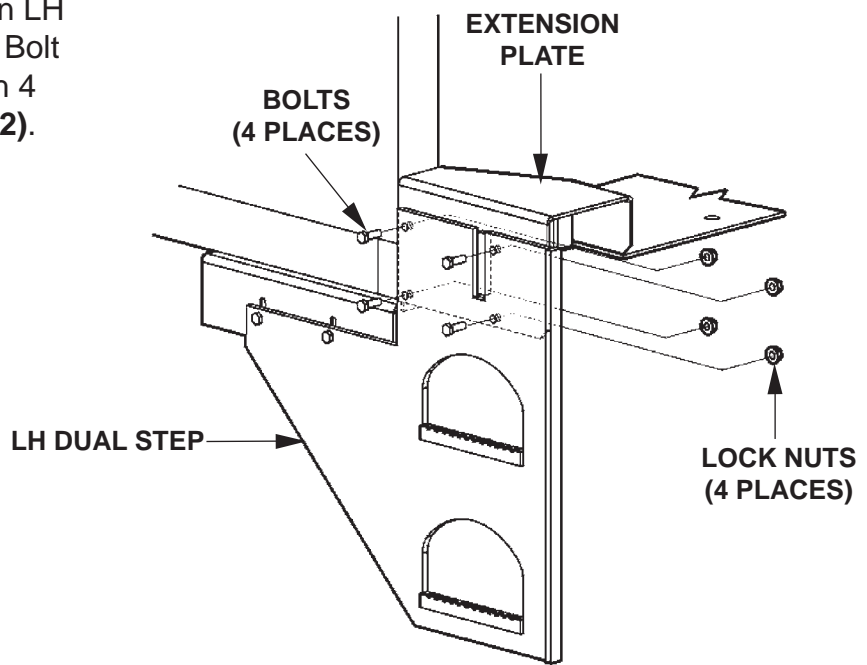

**BOLTING ON THE LH DUAL STEP
FIG. 9-2**

⚠ WARNING

Welding on galvanized parts gives off especially hazardous fumes. Comply with **WARNING** decal on the galvanized part (FIG. 10-1). To minimize hazard remove galvanizing from weld area, provide adequate ventilation, and wear suitable respirator.

3. Butt the step holder angle up against the vehicle body cross members. Then tighten up the 2 bolts on the angle. Weld the step holder angle to vehicle body (FIG. 10-2B).

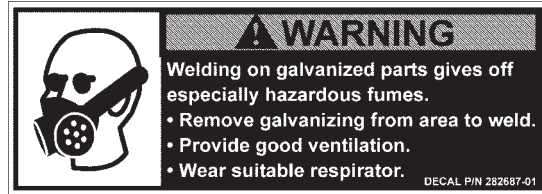
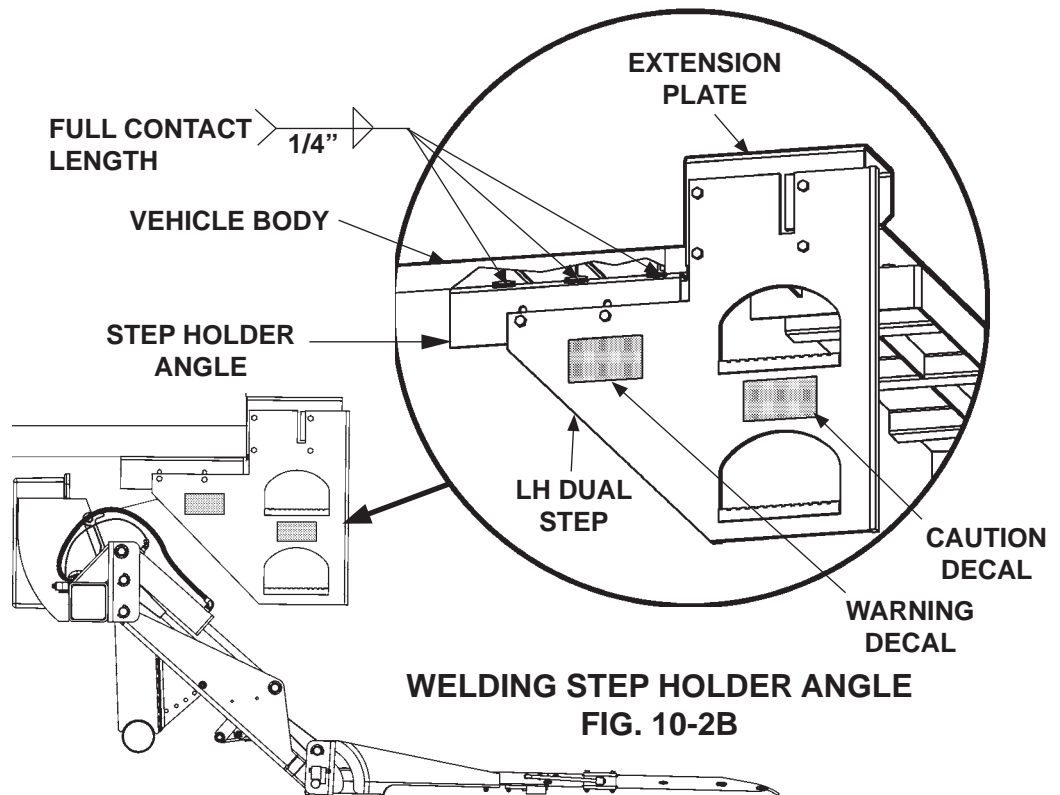

FIG. 10-1



LH DUAL STEP SHOWN
FIG. 10-2A

NOTE: The **CAUTION** decal is used only for the dual steps. The decal is not required on side plate (no steps).

4. Repeat steps 2 and 3 for installing RH dual step on the RH side of extension plate.