

# INSTRUCTION, BMR-A STREETSIDE CONTROL INSTALLATION KIT

## POWER DOWN KIT P/N 282878-01

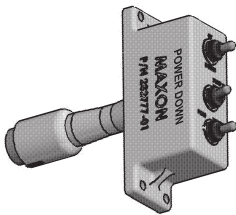

**SWITCH CONTROL  
(POWER DOWN)**  
P/N 282777-01  
QTY. 1

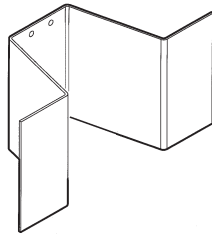

**MOUNTING BRACKET  
(CONTROL SWITCH BOX)**  
P/N 260896  
QTY. 1

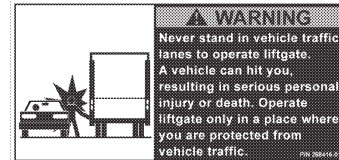

**CONTROL WARNING DECAL**  
P/N 268416-01  
QTY. 2

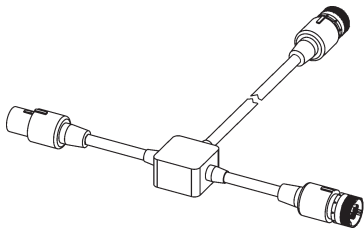

**TEE, STREET SIDE  
CONTROL**  
P/N 282779-02  
QTY. 1

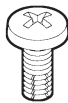

**SELF-TAPPING SCREW,  
#10-24 X 1/2" LG.**  
P/N 030444  
QTY. 4



**PLASTIC TIE  
7" LG.**  
P/N 206864  
QTY. 8



**LOCK WASHER,  
#10**  
P/N 902011-1  
QTY. 4

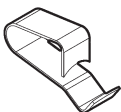

**SPRING CLIP**  
P/N 050079  
QTY. 4

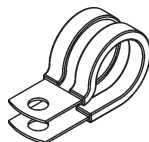

**CLAMP, #6,  
RUBBER LOOM**  
P/N 224006  
QTY. 4



**HEX NUT, #10-32**  
P/N 030344  
QTY. 4

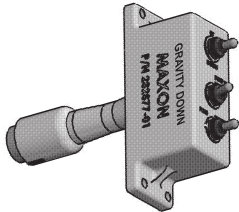

**MACHINE SCREW,  
ROUND HEAD  
#10-32 X 3/4" LG.**  
P/N 900039-6  
QTY. 4

**GRAVITY DOWN KIT P/N 282878-02**

**SWITCH CONTROL  
(GRAVITY DOWN)  
P/N 282877-01  
QTY. 1**

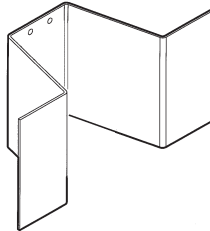

**MOUNTING BRACKET  
(CONTROL SWITCH BOX)  
P/N 260896  
QTY. 1**

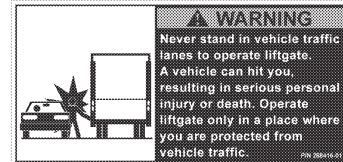

**CONTROL WARNING DECAL  
P/N 268416-01  
QTY. 2**

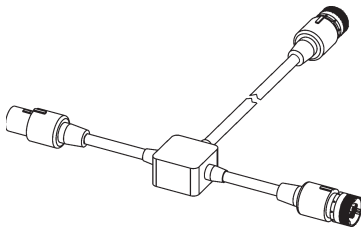

**TEE, STREET SIDE  
CONTROL  
P/N 282779-02  
QTY. 1**

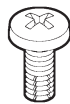

**SELF-TAPPING SCREW,  
#10-24 X 1/2" LG.  
P/N 030444  
QTY. 4**



**PLASTIC TIE  
7" LG.  
P/N 206864  
QTY. 8**



**LOCK WASHER,  
#10  
P/N 902011-1  
QTY. 4**

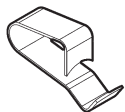

**SPRING CLIP  
P/N 050079  
QTY. 4**

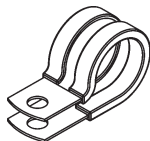

**CLAMP, #6,  
RUBBER LOOM  
P/N 224006  
QTY. 4**



**HEX NUT, #10-32  
P/N 030344  
QTY. 4**



**MACHINE SCREW,  
ROUND HEAD  
#10-32 X 3/4" LG.  
P/N 900039-6  
QTY. 4**

**NOTE:** Liftgate must be lowered to the ground to gain access to underside of vehicle.  
Refer to operating instructions in the Operating Manual.

1. **LOWER** platform to the ground (**FIG. 3-1**).

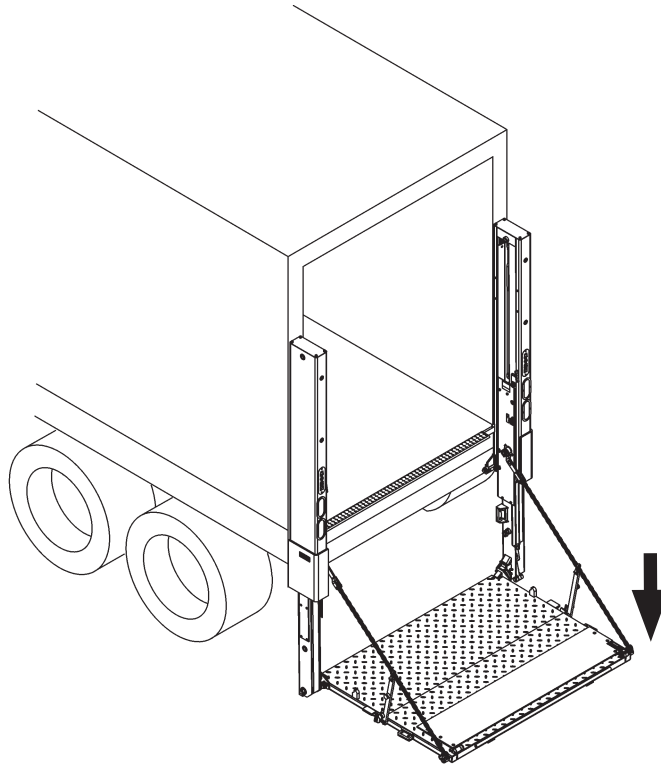

**FIG. 3-1**

2. Remove nut from positive (+) battery terminal connector. Disconnect power cable from the positive (+) battery terminal connector (**FIG. 3-2**).

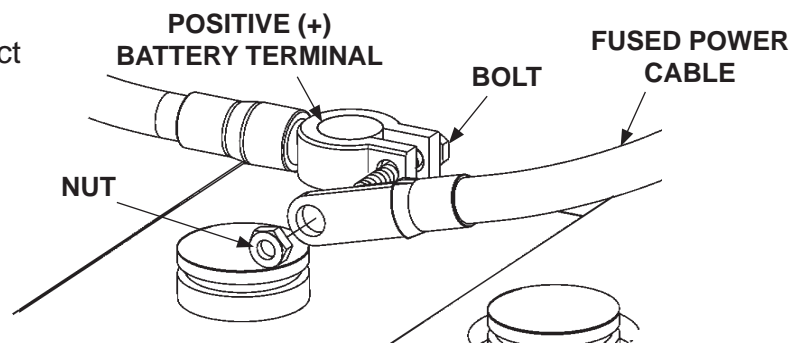

**DISCONNECTING FUSED POWER CABLE**  
**FIG. 3-2**

3. Weld the bracket (Kit item) under the vehicle body on the street side (LH side) of vehicle as shown in **FIGS. 4-1A & 4-1B.**

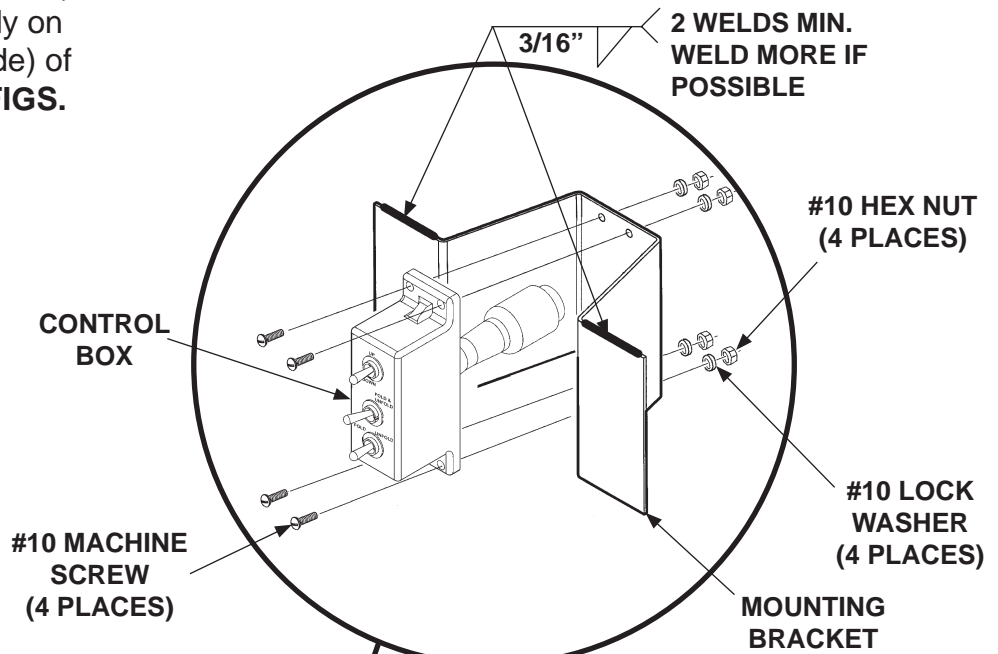

**FIG. 4-1A**

4. Bolt switch control box (Kit item) to bracket with (4) #10 machine screws, (4) #10 lock washers and (4) #10 hex nuts as shown in **FIG. 4-1A.**

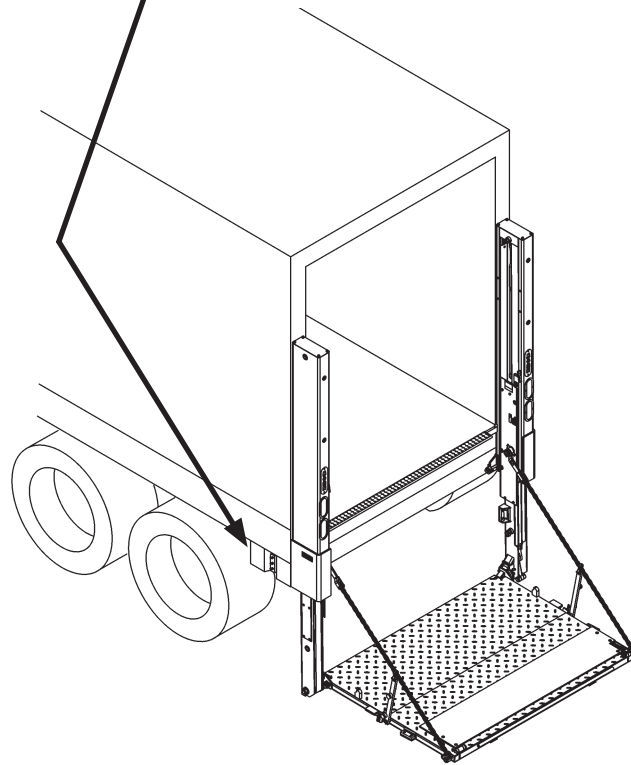
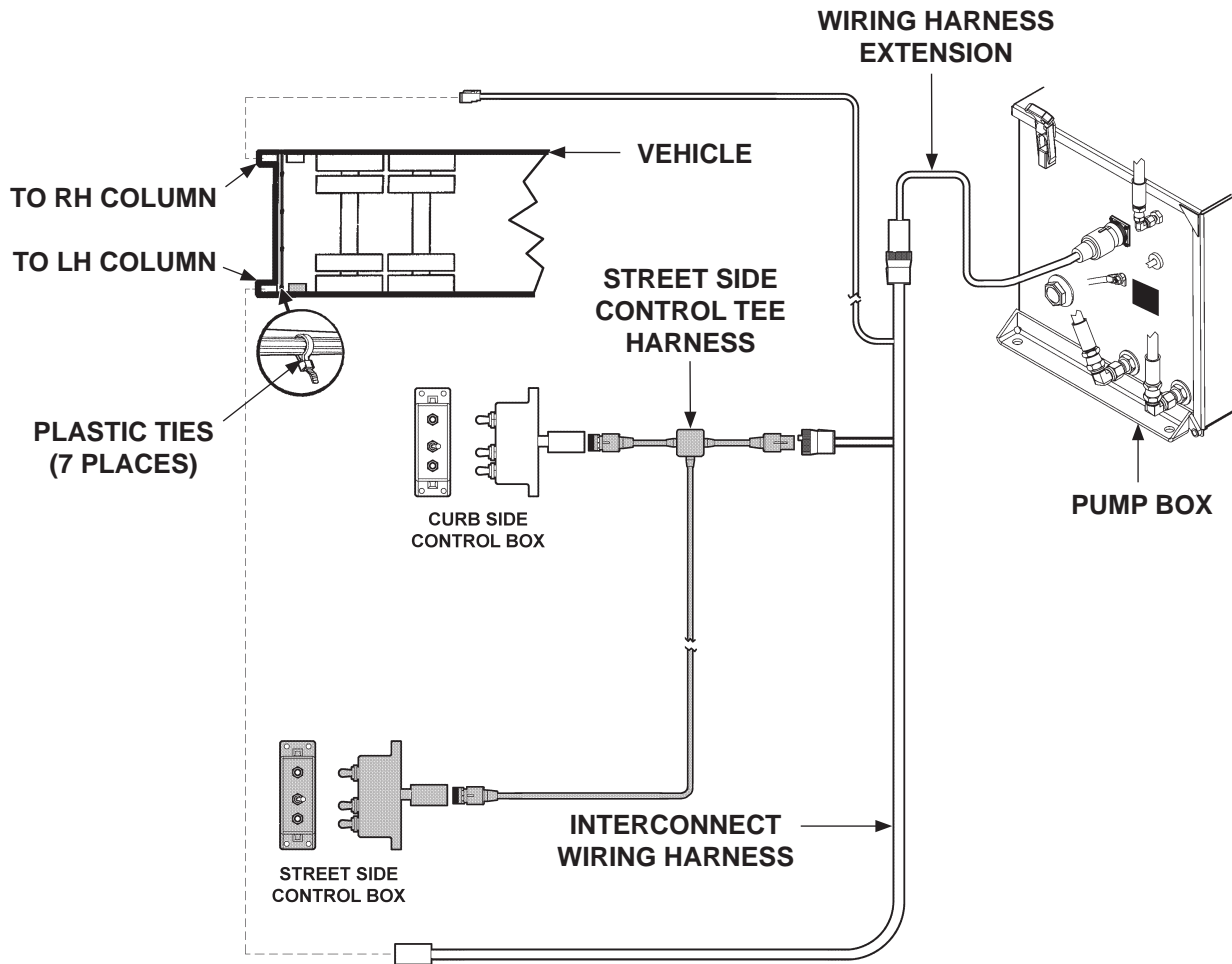

**FIG. 4-1B**

**⚠ CAUTION**

Always route electrical wires clear of moving parts, brake lines, sharp edges and exhaust systems. Avoid making sharp bends in wiring. Attach securely. If drilling is necessary, first check behind the drilling surface so you do not damage any fuel lines, vent lines, brake lines or wires.

5. Disconnect interconnect wiring harness from the curb side (RH side) control box. Connect street side control tee and route wiring from the street side control tee to street side (LH side) of vehicle as shown in **FIG. 5-1**.



**FIG. 5-1**

6. Place **WARNING** decal (Kit item) on vehicle body as shown in **FIG. 6-1**.

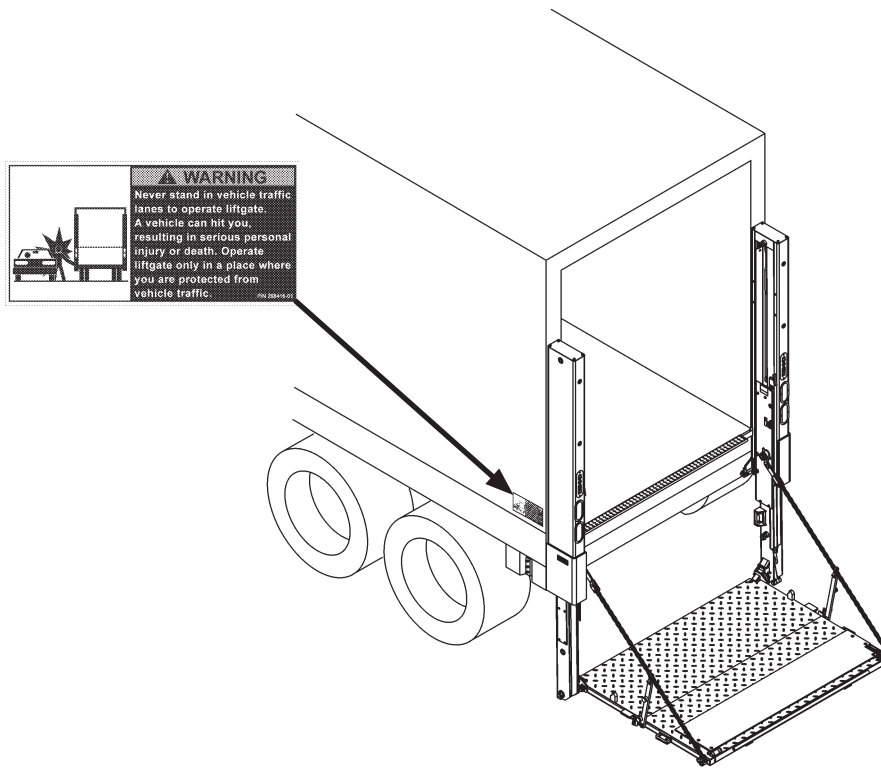

**FIG. 6-1**

7. Remove nut from positive (+) battery terminal connector. Connect power cable to the positive (+) battery terminal connector (**FIG. 7-1**). Reinstall and tighten nut.

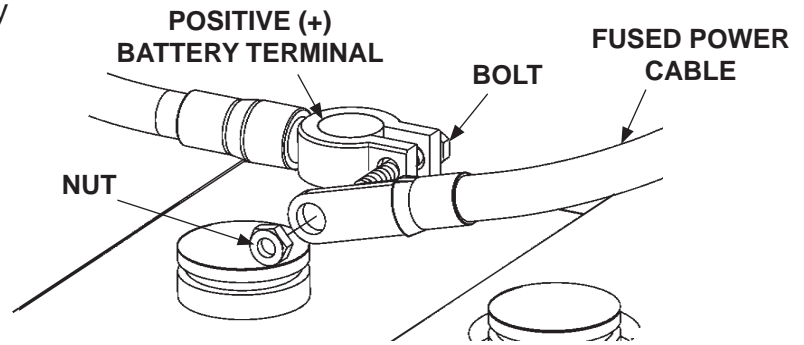

**CONNECTING FUSED POWER CABLE  
FIG. 7-1**

**NOTE:** Verify new street side control switch operates correctly.

8. Raise (**UP**) the platform to bed level (**FIG. 7-2**).

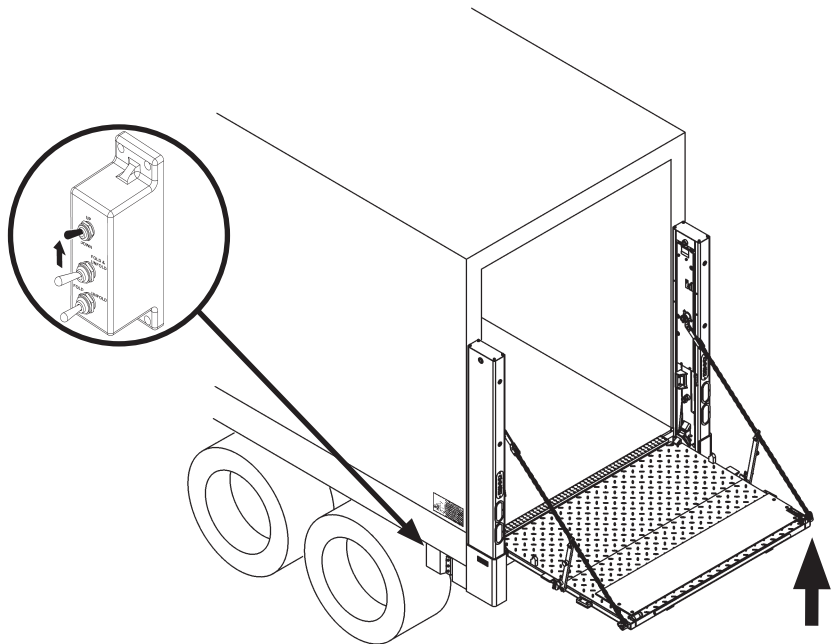

**RAISING PLATFORM  
FIG. 7-2**

9. **FOLD** the platform (**FIG. 8-1**).

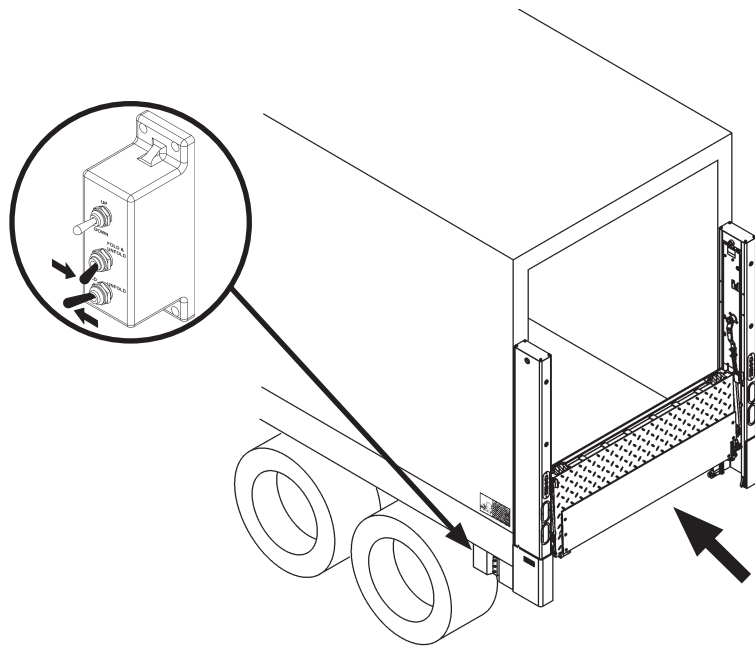

**FOLDING PLATFORM**  
**FIG. 8-1**

10. **UNFOLD** the platform as shown in **FIG. 8-2**.

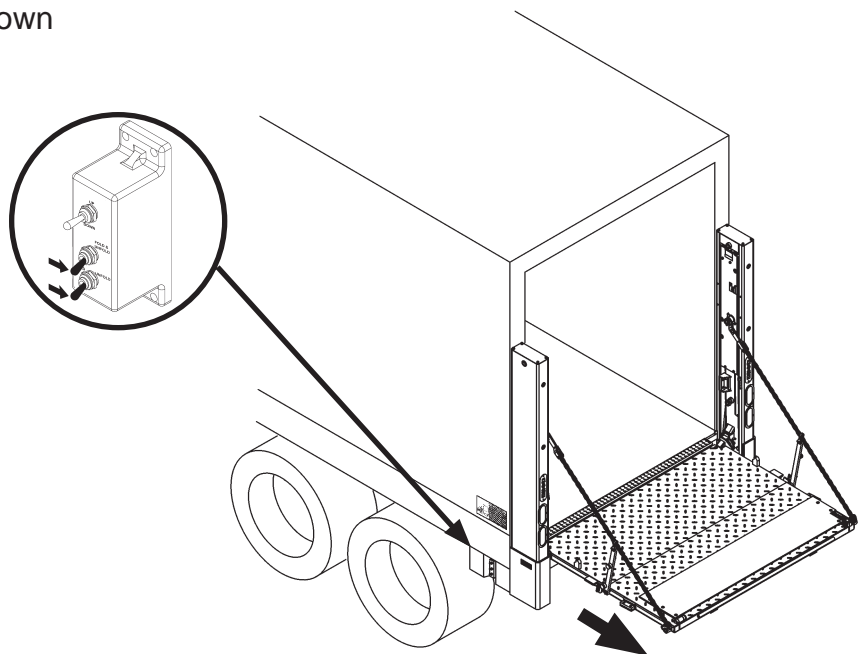

**UNFOLDING PLATFORM**  
**FIG. 8-2**



11. Lower (**DOWN**) the platform to ground level (**FIG. 9-1**).

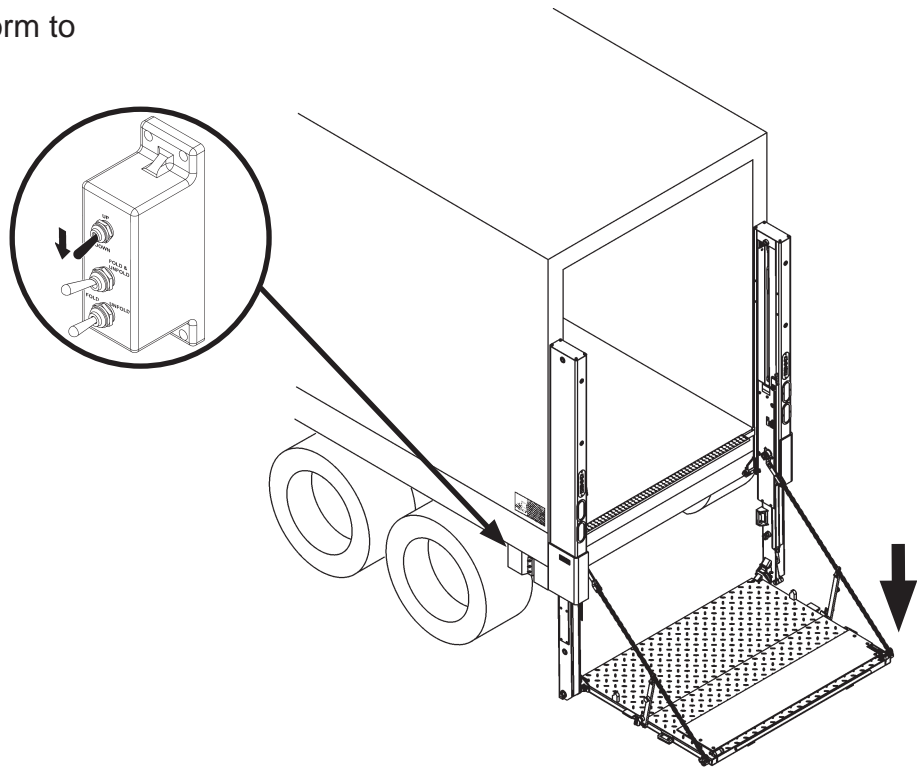

**LOWERING PLATFORM**  
**FIG. 9-1**