

INSTRUCTION, MANUAL HOLDER KIT FIELD KIT P/N 286328-01

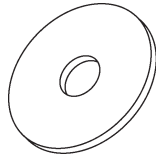

FENDER WASHER, 1/4"
P/N 903409-01
QTY. 8

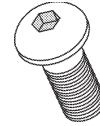

BUTTON HEAD SCREW, 1/4"-20 x 5/8" LG
P/N 900719-04
QTY. 3

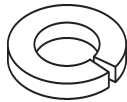

LOCK WASHER
(ALTERNATE VEHICLE INSTALLATION)
P/N 903426-08
QTY. 3



RIVET
(ALTERNATE VEHICLE INSTALLATION)
P/N 903719-04
QTY. 3

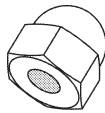

LOCK NUT, 1/4"-20
P/N 905264-05
QTY. 3

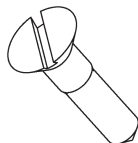

WOOD SCREW
(ALTERNATE VEHICLE INSTALLATION)
P/N 903009-01
QTY. 3

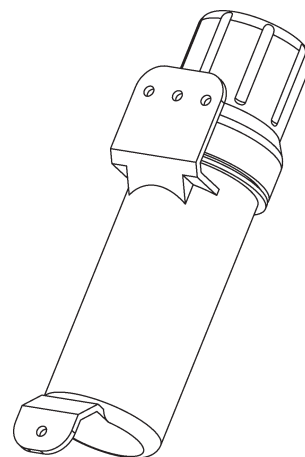

MANUAL HOLDER
P/N 906909-01
QTY. 1

INSTRUCTION, MANUAL HOLDER KIT BATTERY BOX KIT P/N 286328-02

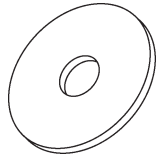

FENDER WASHER, 1/4"
P/N 903409-01
QTY. 8

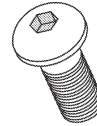

BUTTON HEAD SCREW, 1/4"-20 x 5/8" LG
P/N 900719-04
QTY. 3

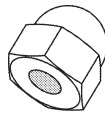

LOCK NUT, 1/4"-20
P/N 905264-05
QTY. 3

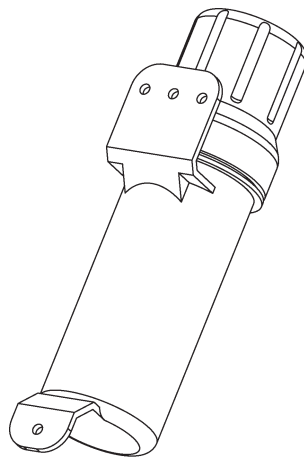

MANUAL HOLDER
P/N 906909-01
QTY. 1

CAUTION

To prevent injuries and equipment damage, prior to beginning this installation, park truck on level ground and set emergency brake.

1. Measure and mark 2 holes on cover as shown in **FIG. 3-1**.

0.26 DIA. (2 PLACES)

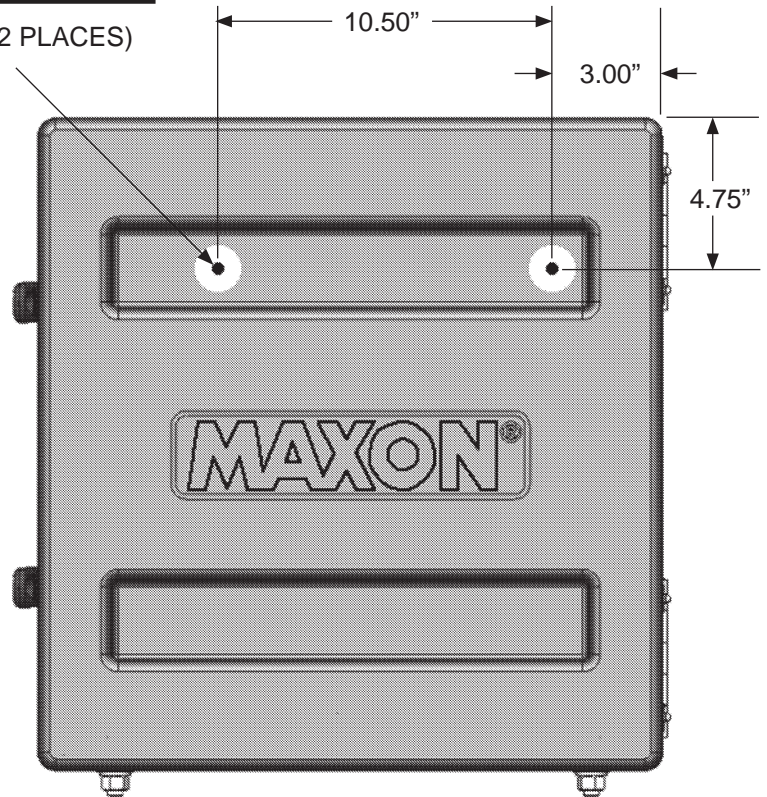

MEASUREMENT FOR HOLES
FIG. 3-1

2. Open cover (**FIG. 3.2**). Drill 2 holes at the marks.

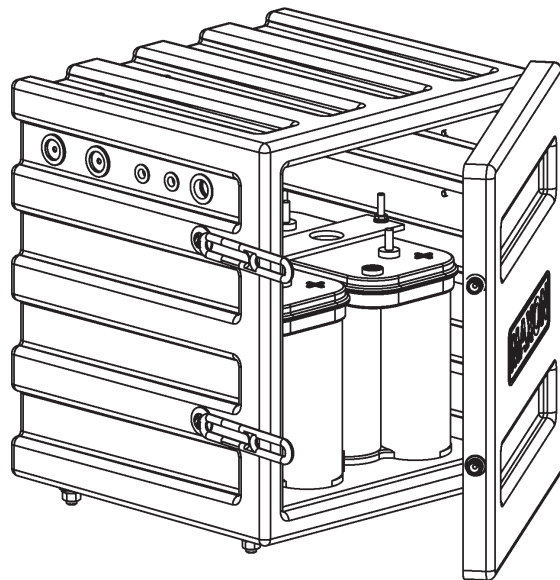

COVER OPENED
FIG. 3-2

3. Remove cover from manual holder (Kit item) as shown in **FIG. 4-1**.

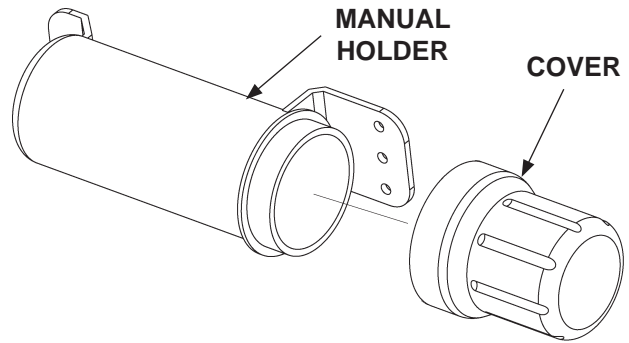

MANUAL HOLDER AND COVER
FIG. 4-1

4. Bolt manual holder to cover with screws, fender washers and lock nuts (Kit items) as shown in **FIG 4-2**.

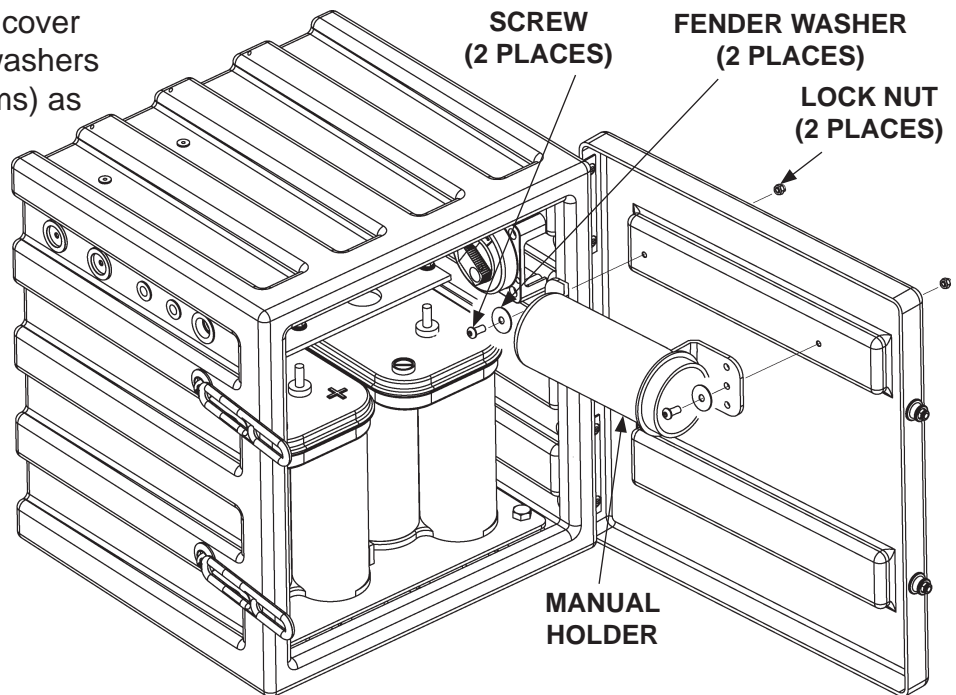

BOLTING ON MANUAL HOLDER
FIG. 4-2

5. Place liftgate operation manual in holder (FIG. 5-1). Then reinstall cover as shown in FIG. 5-2.

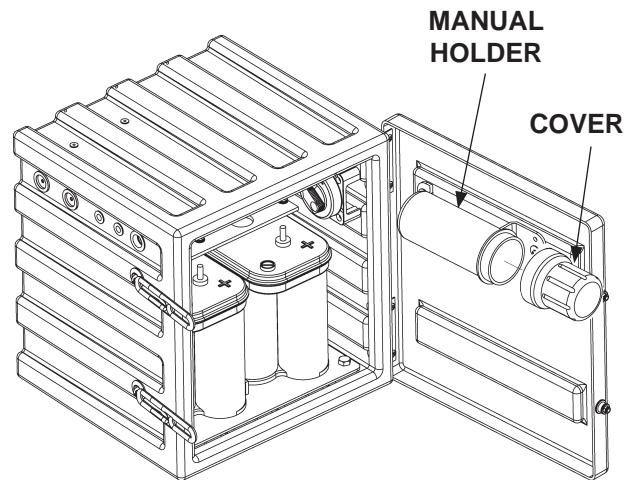

**MANUAL HOLDER COVER OFF
FIG. 5-1**

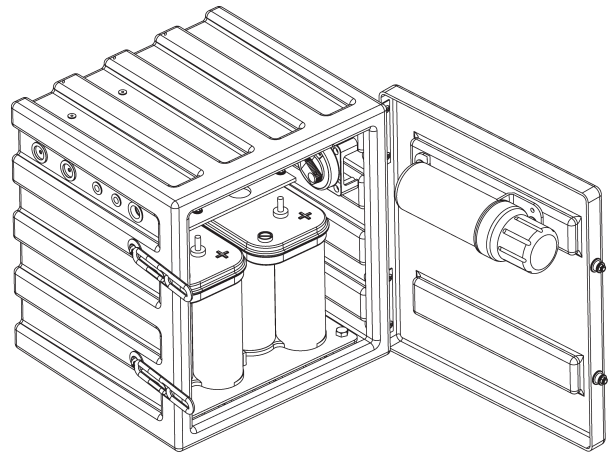

**MANUAL HOLDER COVER ON
FIG. 5-2**

6. Close and latch cover as shown in FIG. 5-3.

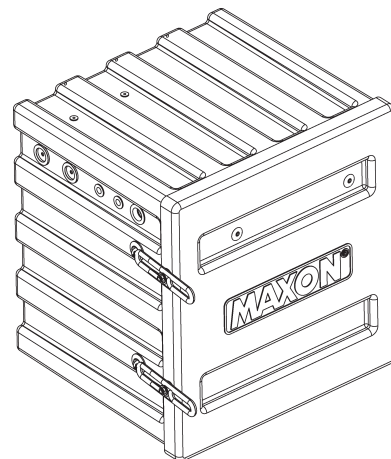

**COVER CLOSED
FIG. 5-3**