

## KIT, ADJUSTABLE HEADER, BMR P/N 263490

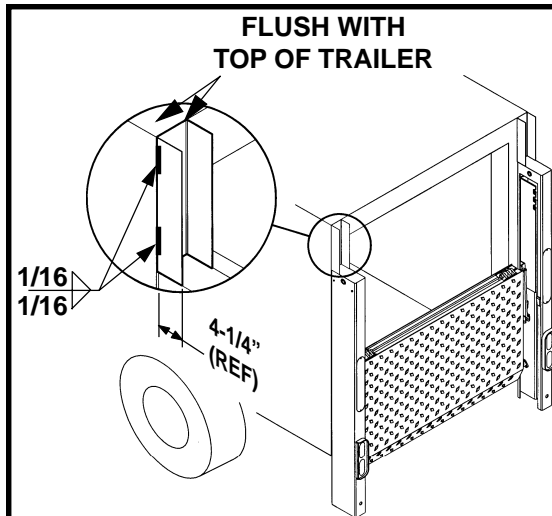

1. Place the two Side Channels on top of the Columns. Cut them to be parallel to the top of the trailer. Weld to the Trailer but be careful not to weld to the liftgate.

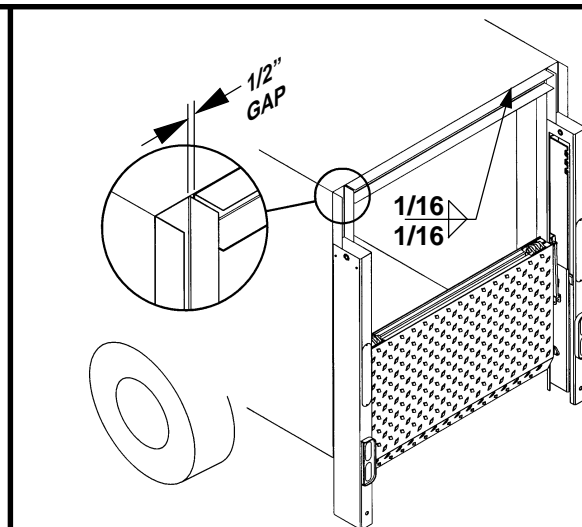

2. Place the top edge of the Horiz. Channel flush with the top of the trailer. Fit the channel inside the two Side Channels with a  $1/2\text{'}$  gap on each side. Weld to Trailer.

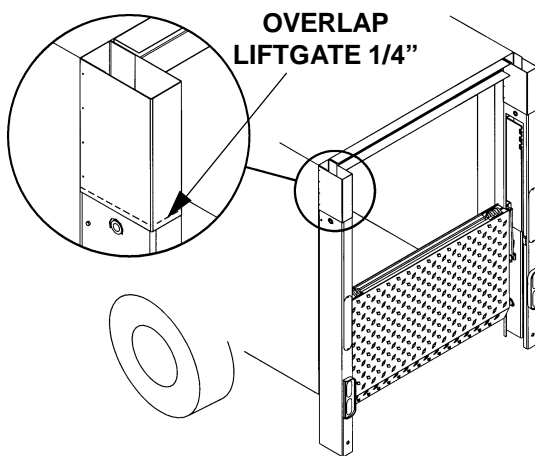

3. Position the Short Channels with holes, over the Side Channels. Use existing holes as a template, drill motor and #10 drill bit to drill holes through the Side Channels. Attach with  $3/16\text{'}$  pop rivets.

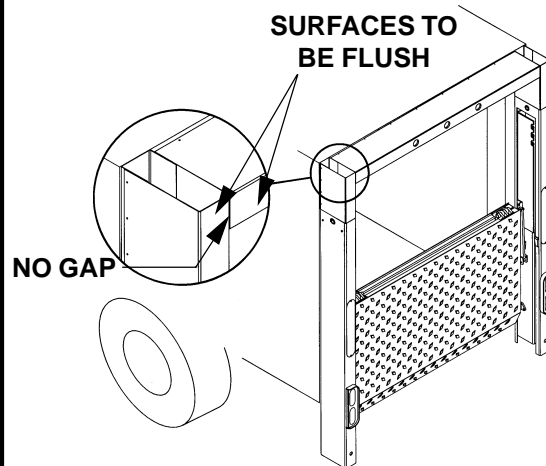

4. Place the Long Channel with holes, over the Horiz. Channel. Use existing holes as a template, drill motor and #10 drill bit to drill holes into the Horiz. Channel. Attach with  $3/16\text{'}$  pop rivets.

