

M-08-14  
REV. F  
APRIL 2020

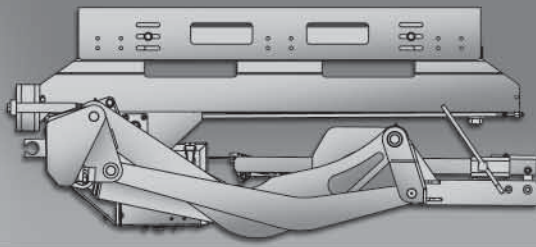

# MAXON<sup>®</sup> GPSLR Series

## MAINTENANCE MANUAL

GPSLR-33 & GPSLR-44; GPSTLR-33 & GPSTLR-44

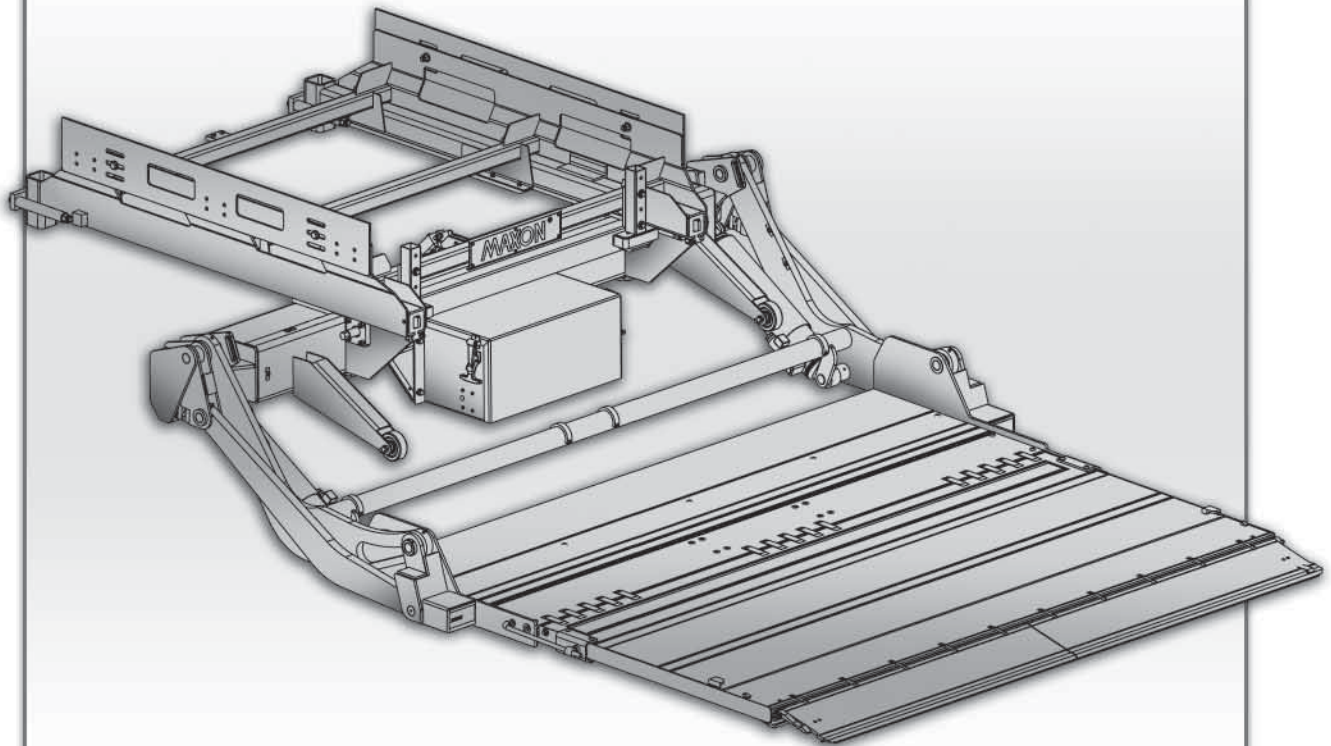



# TABLE OF CONTENTS

<b>SUMMARY OF CHANGES: M-08-14, REVISION H.....</b>	<b>4</b>
<b>WARNINGS.....</b>	<b>5</b>
<b>SAFETY INSTRUCTIONS .....</b>	<b>6</b>
LIFTGATE TERMINOLOGY .....	7
<b>PERIODIC MAINTENANCE.....</b>	<b>9</b>
PERIODIC MAINTENANCE CHECKS.....	9
PERIODIC MAINTENANCE CHECKLIST.....	10
CHECKING HYDRAULIC FLUID .....	12
CHANGING HYDRAULIC FLUID .....	14
PLATFORM ADJUSTMENT .....	16
DRIVE CHAIN ADJUSTMENT .....	18
DECALS .....	20
<b>SYSTEM DIAGRAMS .....</b>	<b>24</b>
PUMP & MOTOR SOLENOID OPERATION .....	24
HYDRAULIC SCHEMATIC .....	25
ELECTRICAL SCHEMATIC.....	26
<b>TROUBLESHOOTING .....</b>	<b>27</b>

## SUMMARY OF CHANGES: M-08-14, REVISION H

PAGE	DESCRIPTION OF CHANGE
COVER	Updated REV, date of release and cover image.
-	Cover image and applicable Illustrations throughout manual are updated to show new impact-absorbing tubes on the back of the slider frame.
-	This contents of this manual applies only to GPSLR liftgates equipped with standard control switches. All information about SmartStow controls was removed.
5	Added California Proposition 65 warning.
7	Updated terminology to show standard external control switches.
13	Added Phillips 66 Arctic Low Pour oil to table of recommended ISO-15 oils.
20	Changed Operation decal to latest decal with QR code and added decal with parts QR code.
22	Added MAXGRIP decal for platforms with knurled surface.
23	Decal H updated to show new retention ramp.
23	Changed PRV setting to 1500 PSI on Hydraulic Schematic.

**MAXON®**

11921 Slauson Ave. Santa Fe Springs, CA. 90670 (800) 227-4116 FAX (888) 771-7713

Comply with the following **WARNINGS** and **SAFETY INSTRUCTIONS** while maintaining Liftgates. See Operation Manual for operating safety requirements.

## **WARNING**

Installing and maintaining a liftgate can expose you to chemicals, including lead, which are known to the State of California to cause cancer and birth defects or other reproductive harm. To minimize exposure, install and maintain liftgate in a well-ventilated area and wear **proper Personal protective equipment (PPE)**. For more information go to [www.P65Warnings.ca.gov](http://www.P65Warnings.ca.gov).

## **WARNING**

- Do not stand, or allow obstructions, under the platform when lowering the Liftgate. **Be sure your feet are clear of the Liftgate.**
- **Keep fingers, hands, arms, legs, and feet clear of moving Liftgate parts (and platform edges) when operating the Liftgate.**
- **Correctly stow platform when not in use. Extended platforms could create a hazard for people and vehicles passing by.**
- **Disconnect Liftgate power cable from battery** before repairing or servicing Liftgate.
- If it is necessary to stand on the platform while maintaining the Liftgate, keep your feet and any objects clear of the inboard edge of the platform. Your feet or objects on the platform can become trapped between the platform and the Liftgate extension plate.
- Recommended practices for welding on steel parts are contained in the current **AWS (American Welding Society) D1.1 Structural Welding Code - Steel**. Damage to Liftgate and/or vehicle, and personal injury could result from welds that are done incorrectly.
- Recommended practices for welding on aluminum parts are contained in the current **AWS (American Welding Society) D1.2 Structural Welding Code - Aluminum**. Damage to Liftgate and/or vehicle, and personal injury could result from welds that are done incorrectly.
- Recommended practices for welding galvanized steel are contained in the current **AWS (American Welding Society) D19.0 Welding Zinc-Coated Steel**. Damage to Liftgate and/or vehicle, and personal injury can result from welds that are done incorrectly.

# SAFETY INSTRUCTIONS

- Read and understand the instructions in this **Maintenance Manual** before performing maintenance on the Liftgate.
- Before operating the Liftgate, read and understand the operating instructions in **Operation Manual**.
- Comply with all **WARNING** and instruction decals attached to the Liftgate.
- Keep decals clean and legible. If decals are illegible or missing, replace them. Free replacement decals are available from **Maxon Customer Service**.
- Consider the safety and location of bystanders and location of nearby objects when operating the Liftgate. Stand to one side of the platform while operating the Liftgate.
- Do not allow untrained persons to operate the Liftgate.
- Wear appropriate safety equipment such as protective eyeglasses, faceshield and clothing while performing maintenance on the Liftgate and handling the battery. Debris from drilling and contact with battery acid may injure unprotected eyes and skin.
- Be careful working by an automotive type battery. Make sure the work area is well ventilated and there are no flames or sparks near the battery. Never lay objects on the battery that can short the terminals together. If battery acid gets in your eyes, immediately seek first aid. If acid gets on your skin, immediately wash it off with soap and water.
- If an emergency situation arises (vehicle or Liftgate) while operating the Liftgate, release the control switch to stop the Liftgate.
- A correctly installed Liftgate operates smoothly and reasonably quiet. The only noticeable noise during operation comes from the power unit while the platform is raised. Listen for scraping, grating and binding noises and correct the problem before continuing to operate Liftgate.
- Use only **Maxon Authorized Parts** for replacement parts. Provide Liftgate model and serial number information with your parts order. Order replacement parts from:

**MAXON LIFT CORP. Customer Service**  
**11921 Slauson Ave., Santa Fe Springs, CA 90670**

**Online: [www.maxonlift.com](http://www.maxonlift.com)**  
**Express Parts Ordering: Phone (800) 227-4116 ext. 4345**  
**Email: Ask your Customer Service representative**

**MAXON**<sup>®</sup>

11921 Slauson Ave. Santa Fe Springs, CA. 90670 (800) 227-4116 FAX (888) 771-7713

# LIFTGATE TERMINOLOGY

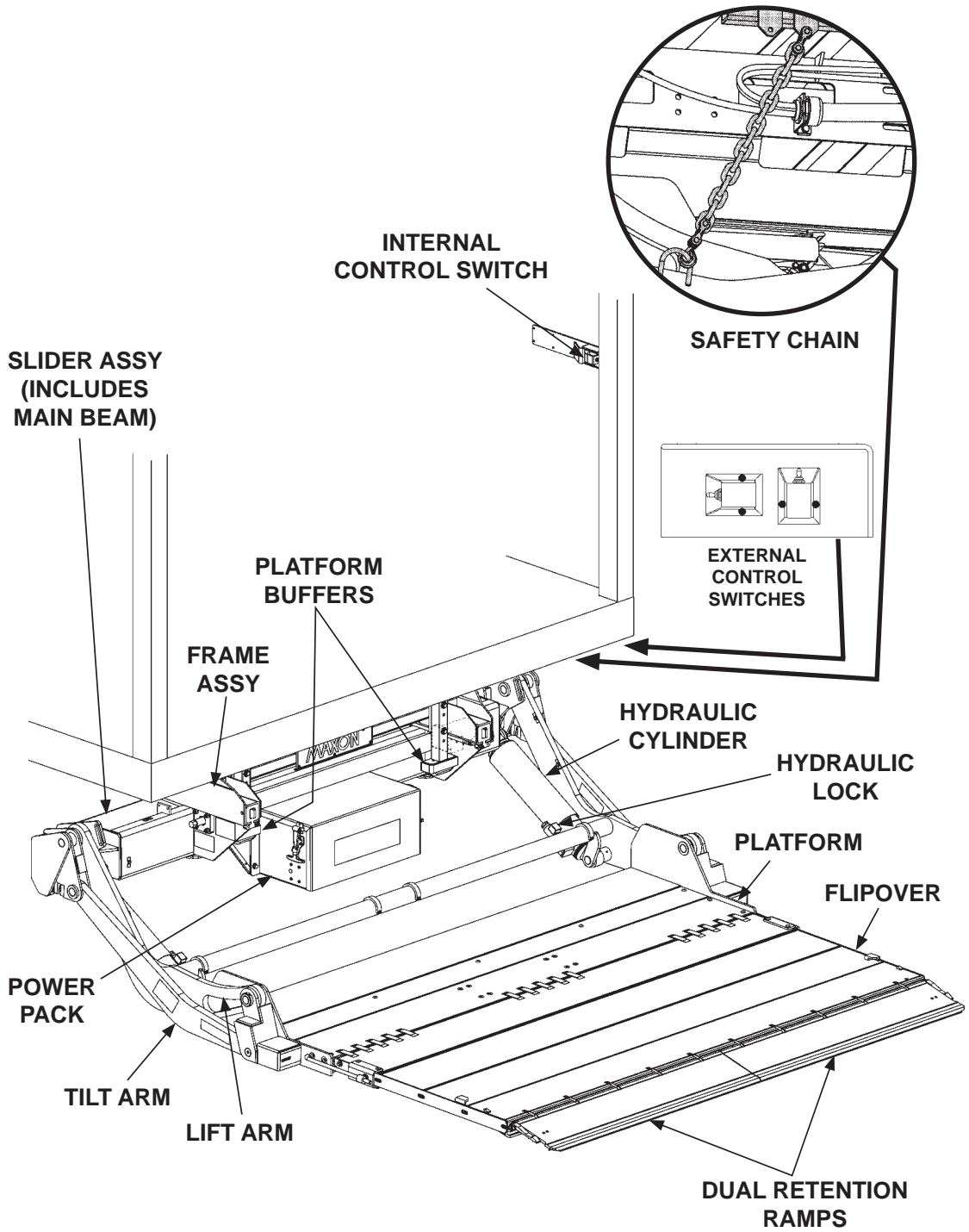

THIS PAGE INTENTIONALLY LEFT BLANK

**MAXON**<sup>®</sup>

11921 Slauson Ave. Santa Fe Springs, CA. 90670 (800) 227-4116 FAX (888) 771-7713



## PERIODIC MAINTENANCE PERIODIC MAINTENANCE CHECKS

### **⚠ WARNING**

**Never operate the Liftgate if parts are loose or missing.**

**NOTE:** Make sure vehicle is parked on level ground while performing the maintenance checks.

### **Quarterly or 1250 Cycles (whichever occurs first)**

Check the hydraulic fluid level in the pump reservoir. Refer to the **CHECKING HYDRAULIC FLUID** procedure in the **PERIODIC MAINTENANCE** section. Keep track of the grade of hydraulic fluid in the pump reservoir and never mix two different grades of fluid.

If hydraulic fluid appears contaminated, refer to the **CHANGING HYDRAULIC FLUID** procedure in the **PERIODIC MAINTENANCE** section.

Check all hoses and fittings for chafing and fluid leaks. Tighten loose fittings or replace parts as required.

Check electrical wiring for chafing and make sure wiring connections are tight and free of corrosion.

Check that all **WARNING** and **instruction decals** are in place. Also, make sure decals are legible, clean and undamaged.

Check that all bolts, nuts, and roll pins are in place. Make sure roll pins protrude evenly from both sides of hinge pin collar. Replace fasteners and roll pins if necessary.

Check for debris and dirt buildup on the slider rollers and rails. Clean out any buildup of dirt and debris.

### **CAUTION**

**Damaged cylinder seals and contaminated hydraulic fluid can result from painting the polished portion of the cylinder rod. To prevent damage, protect the exposed polished portion of the cylinder rod while painting.**

Check for rust and oily surfaces on Liftgate. If there is rust or oil on Liftgate, clean it off. Touch up the paint, where bare metal is showing, with aluminum primer touchup paint.

Pump EP chassis grease in each lube fitting on the cylinders and arms until grease starts oozing from ends of the bearings. The lubrication diagram on the **PERIODIC MAINTENANCE CHECKLIST SHEET** shows where to find the lube fittings. Wipe off excess grease with a clean lint-free cloth.

Check that safety chain and snap hook are in place on models with no controller.

### **Semi-annually or 2500 Cycles (whichever occurs first)**

Visually check the platform hinge pins for excessive wear and broken welds. See **PARTS BREAKDOWN** section for replacement parts. Also, do the **Quarterly or 1250 Cycles** maintenance checks.

## PERIODIC MAINTENANCE CHECKLIST

**NOTE:** Make sure vehicle is parked on level ground while performing maintenance checks.

### Quarterly or 1250 Cycles (whichever occurs first)

- Check the level and condition of the hydraulic fluid.
- Visually check all hoses and fittings for chafing and fluid leaks. Tighten loose fittings or replace parts as required.
- Check electrical wiring for chafing and make sure wiring connections are tight and free of corrosion. Use dielectric grease to protect electrical connections.
- Check that all **WARNING and instruction decals** are in place. Also, make sure decals are legible, clean, and undamaged.
- Check that all bolts, nuts, and roll pins are in place. Make sure roll pins protrude evenly from both sides of hinge pin collar. Replace fasteners and roll pins if necessary.
- Check for debris and dirt buildup on the slider rollers and rails. Clean out any buildup of dirt and debris.
- Check for rust and oily surfaces on Liftgate. If there is rust or oil on Liftgate or if the Liftgate is dirty, clean it off. Touch up the paint where bare metal is showing. Refer to the paint system **CAUTION** and recommended touchup paint on the preceding page.
- Pump EP chassis grease in each lube fitting on the cylinders and arms until grease starts oozing from ends of the bearings. The lubrication diagram on the **PERIODIC MAINTENANCE CHECKLIST SHEET** shows where to find the lube fittings. Wipe off excess grease with a clean lint-free cloth.
- Check that safety chain and snap hook are in place on models with no controller.

### Semi-annually or 2500 Cycles (whichever occurs first)

- Visually check the platform hinge pins for excessive wear and broken welds.
- Do the **Quarterly or 1250 Cycles Checks** on this checklist.

**MAXON**<sup>®</sup>

11921 Slauson Ave. Santa Fe Springs, CA. 90670 (800) 227-4116 FAX (888) 771-7713

**NOTE:** Lube fittings are shown for the LH cylinder, lift arm, and tilt arm. There are also lube fittings at the same places on the RH cylinder, lift arm, and tilt arm.

Refer to lubrication diagram (**FIG. 11-1**) to find the lube fittings on cylinders and arms. Pump EP chassis grease in each lube fitting on the cylinders and arms until grease starts oozing from ends of the bearings. Then, wipe off excess grease with a clean lint-free cloth.

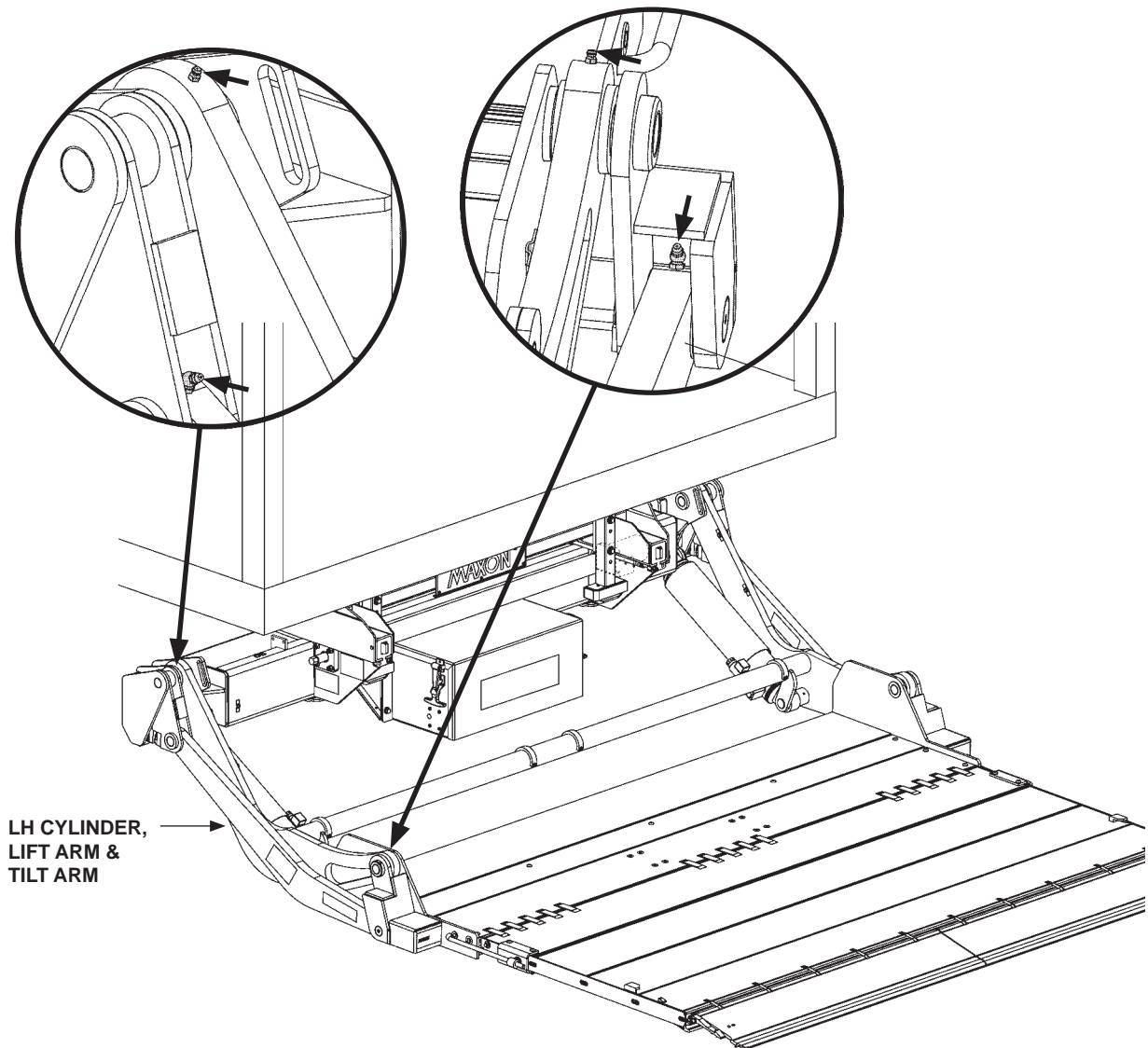

**GPSLR LUBRICATION DIAGRAM  
FIG. 11-1**

## CHECKING HYDRAULIC FLUID

### CAUTION

Keep dirt, water and other contaminants from entering the hydraulic system. Before opening the hydraulic fluid reservoir filler cap, drain plug and hydraulic lines, clean up contaminants that can get in the openings. Also, protect the openings from accidental contamination.

**NOTE:** Use correct grade of hydraulic fluid for your location.

**+50 to +120 Degrees F - Grade ISO 32**

**Below +70 Degrees F - Grade ISO 15 or MIL-H-5606**

See **TABLES 13-1 & 13-2** for recommended brands.

1. Unstow and lower Liftgate to ground.
2. Unlatch and open pump cover (**FIG. 12-1**).
3. Check the hydraulic fluid level in reservoir as follows. With Liftgate on ground, level should be as shown in **FIG. 12-2**.

**NOTE:** If the hydraulic fluid in the reservoir is contaminated, do the **CHANGING HYDRAULIC FLUID** procedure in this section.

### CAUTION

Do not fill reservoir to the **FULL** mark on the dipstick. Hydraulic fluid can overflow from the reservoir.

4. If needed, add hydraulic fluid to the reservoir as follows. Remove filler cap (**FIG. 12-2**). Fill the reservoir with hydraulic fluid to 3/4" above bottom of dipstick (**FIG. 12-2**). Reinstall filler cap (**FIG. 12-2**).

### CAUTION

Pump cover must be correctly secured to prevent it from becoming a hazard. Ensure pump cover is latched to pump box.

5. Close and latch the pump cover as shown in **FIG. 12-1**.

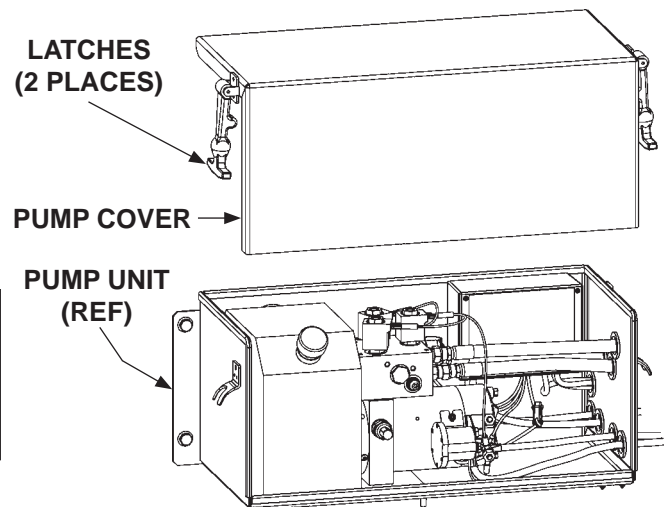

**UNLATCH/LATCH PUMP COVER**  
**FIG. 12-1**

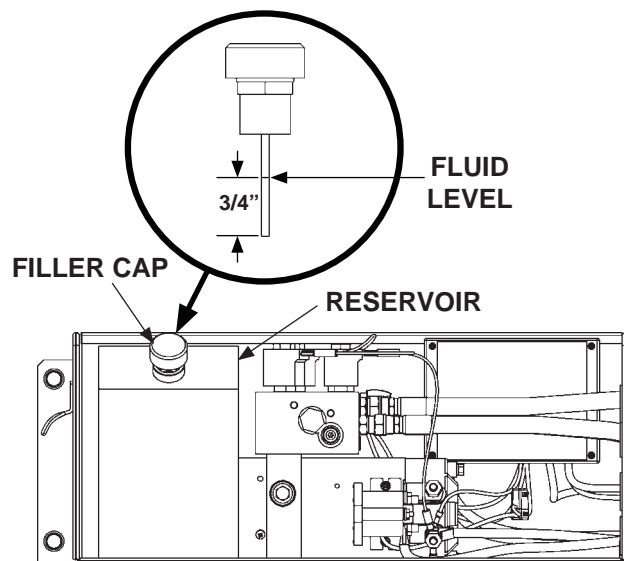

**POWER UNIT FLUID LEVEL**  
**FIG. 12-2**

ISO 32 HYDRAULIC OIL	
RECOMMENDED BRANDS	PART NUMBER
CHEVRON	HIPERSYN 32
KENDALL	GOLDEN MV
SHELL	TELLUS S2 VX 32
EXXONMOBIL	UNIVIS N-32, DTE-24

**TABLE 13-1**

ISO 15 OR MIL-H-5606 HYDRAULIC OIL	
RECOMMENDED BRANDS	PART NUMBER
CHEVRON	FLUID A, AW-MV-15
KENDALL	GLACIAL BLU
SHELL	TELLUS S2 VX 15
EXXONMOBIL	UNIVIS HVI-13
PHILLIPS 66	ARCTIC LOW POUR
ROSEMEAD	THS FLUID 17111

**TABLE 13-2**

## CHANGING HYDRAULIC FLUID

### CAUTION

Keep dirt, water and other contaminants from entering the hydraulic system. Before opening the hydraulic fluid reservoir filler cap, drain plug and hydraulic lines, clean up contaminants that can get in the openings. Also, protect the openings from accidental contamination.

**NOTE:** Use correct grade of hydraulic fluid for your location.

**+50 to +120 Degrees F - Grade ISO 32**

**Below +70 Degrees F - Grade ISO 15 or MIL-H-5606**

See **TABLES 13-1 & 13-2** for recommended brands.

1. Unstow and lower Liftgate to ground.

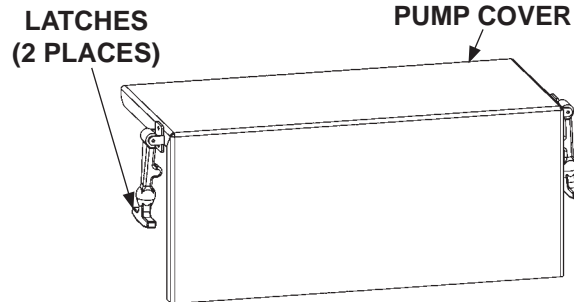

2. Unlatch and open the pump cover (**FIG. 14-1**).

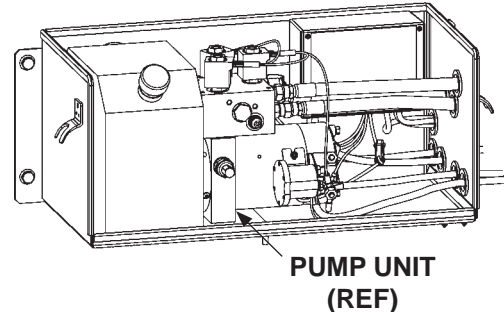

**UNLATCH PUMP COVER**  
**FIG. 14-1**

3. Place empty 5 gallon bucket under drain plug (**FIG. 14-2**). Remove drain plug (**FIG. 14-2**). Drain hydraulic fluid. Re-install drain plug (**FIG. 14-2**).

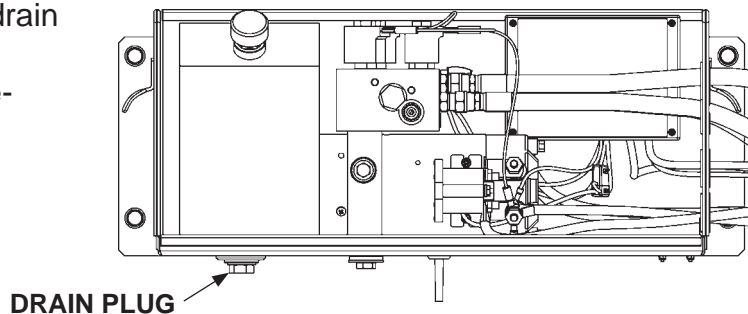

**POWER UNIT**  
**FIG. 14-2**

**MAXON**<sup>®</sup>

11921 Slauson Ave. Santa Fe Springs, CA. 90670 (800) 227-4116 FAX (888) 771-7713

## CAUTION

Do not fill reservoir to the FULL mark on the dipstick. Hydraulic fluid can overflow from the reservoir.

4. Remove filler cap (FIG. 15-1). Add 1 gallon of hydraulic fluid to the reservoir. Hydraulic fluid level should be 3/4" above bottom of dipstick (FIG. 15-1). Reinstall filler cap (FIG. 15-1).
5. Stow the lift and do the **CHECKING HYDRAULIC FLUID** procedure in this section of the manual.

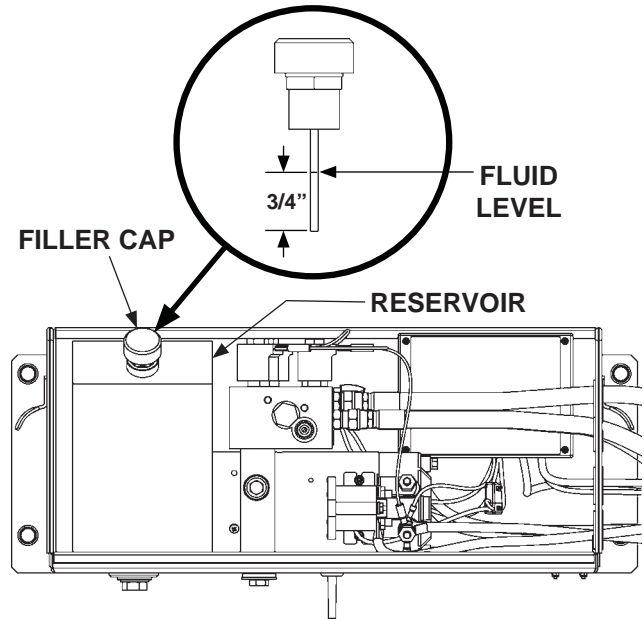

POWER UNIT  
FIG. 15-1

## CAUTION

Pump cover must be correctly secured to prevent it from becoming a hazard. Ensure pump cover is latched to pump box.

6. Close and latch the pump cover as shown in FIG. 15-2.

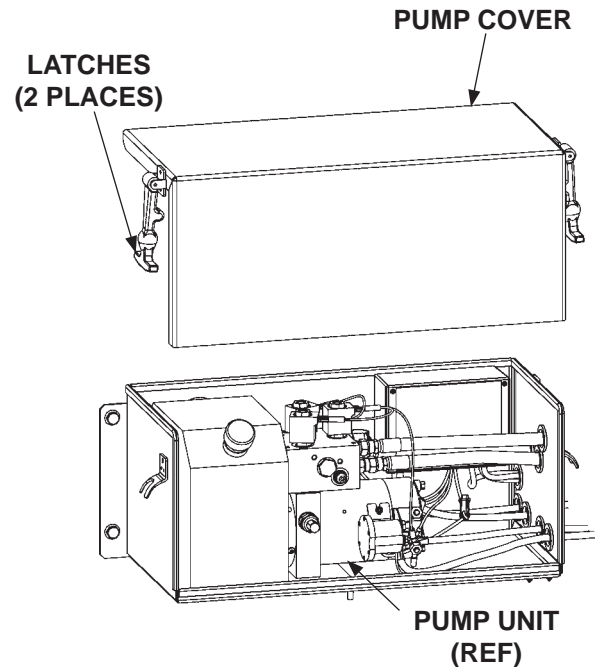

UNLATCH PUMP COVER  
FIG. 15-2

## PLATFORM ADJUSTMENT

**NOTE:** Park vehicle on level ground and unload vehicle before doing this procedure.

1. Lower platform to ground and unfold flipover (FIG. 16-1A).
2. Loosen adjustment and limit bolts on both sides of platform (FIG. 16-1B).
3. Turn adjustment bolts counter-clockwise to tilt the tip of platform up (FIG. 16-2), or turn clockwise to tilt down (FIG. 16-3).
4. Once platform is adjusted, tighten limit bolts securely on both sides of platform (FIG. 16-1B).

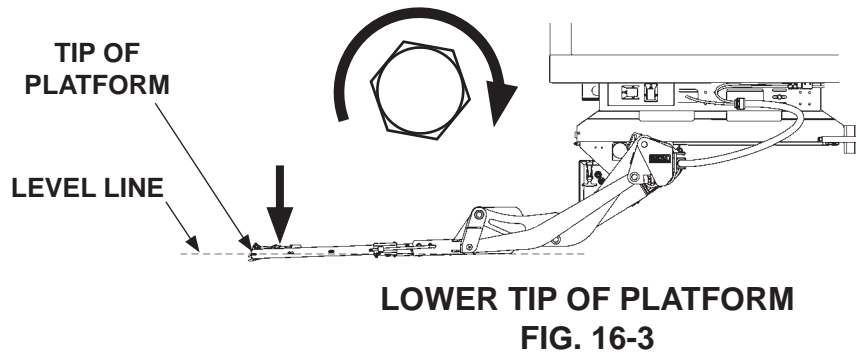
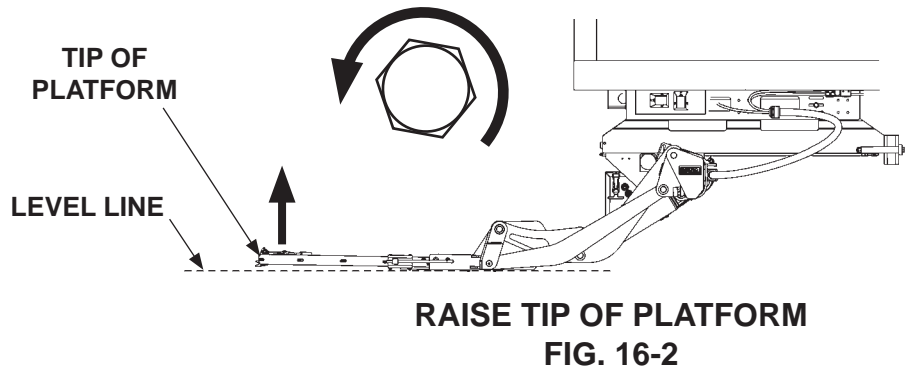
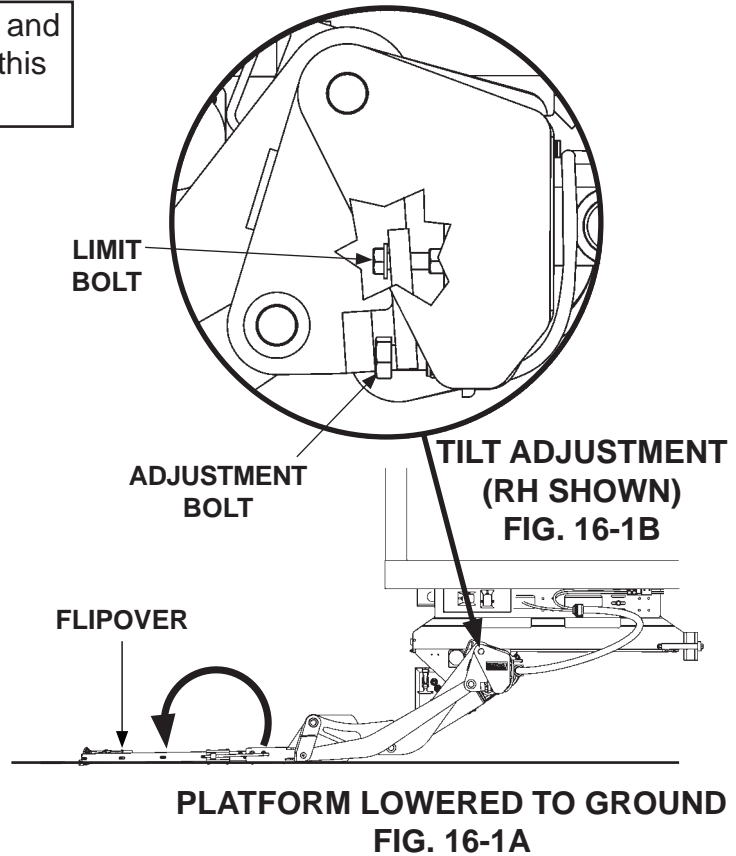



THIS PAGE INTENTIONALLY LEFT BLANK

## DRIVE CHAIN ADJUSTMENT

**NOTE:** Improperly adjusted drive chains cause slide frame binding. Normal slide frame runout speed is from 5-8 seconds.

1. Lower the slide frame so it can be moved out. See **GPSLR/GPSTLR Operations Manual (M-08-13)**.
2. Move the slide frame out (**FIG. 18-1**). See **GPSLR/GPSTLR Operations Manual (M-08-13)**.

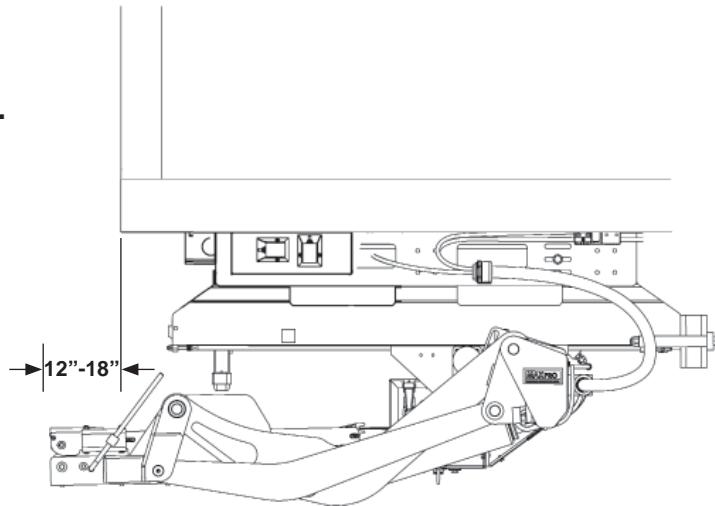

**POSITION SLIDE FRAME  
FIG. 18-1**

3. Measure and record the distance from the front edge of the plate below the chain roller wheels, to the end of the chain rail assembly (**FIG. 18-2**). Repeat measurement for both chains.

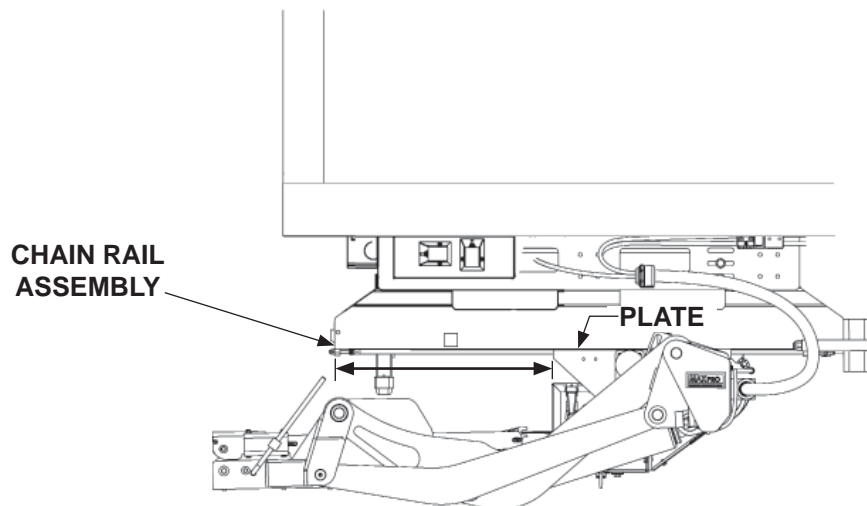

**MEASURE DRIVE CHAIN DIMENSIONS  
FIG. 18-2**

**MAXON**<sup>®</sup>

11921 Slauson Ave. Santa Fe Springs, CA. 90670 (800) 227-4116 FAX (888) 771-7713

- Adjust the chain with smallest measured dimension, to match the chain with longest measured dimension, as follows. Loosen chain adjuster nut at the rear of the chain rail assembly. Then, turn the front adjuster nut clockwise to extend the shortest chain to match the longest chain dimension (**FIGS. 19-1A & 19-1B**).

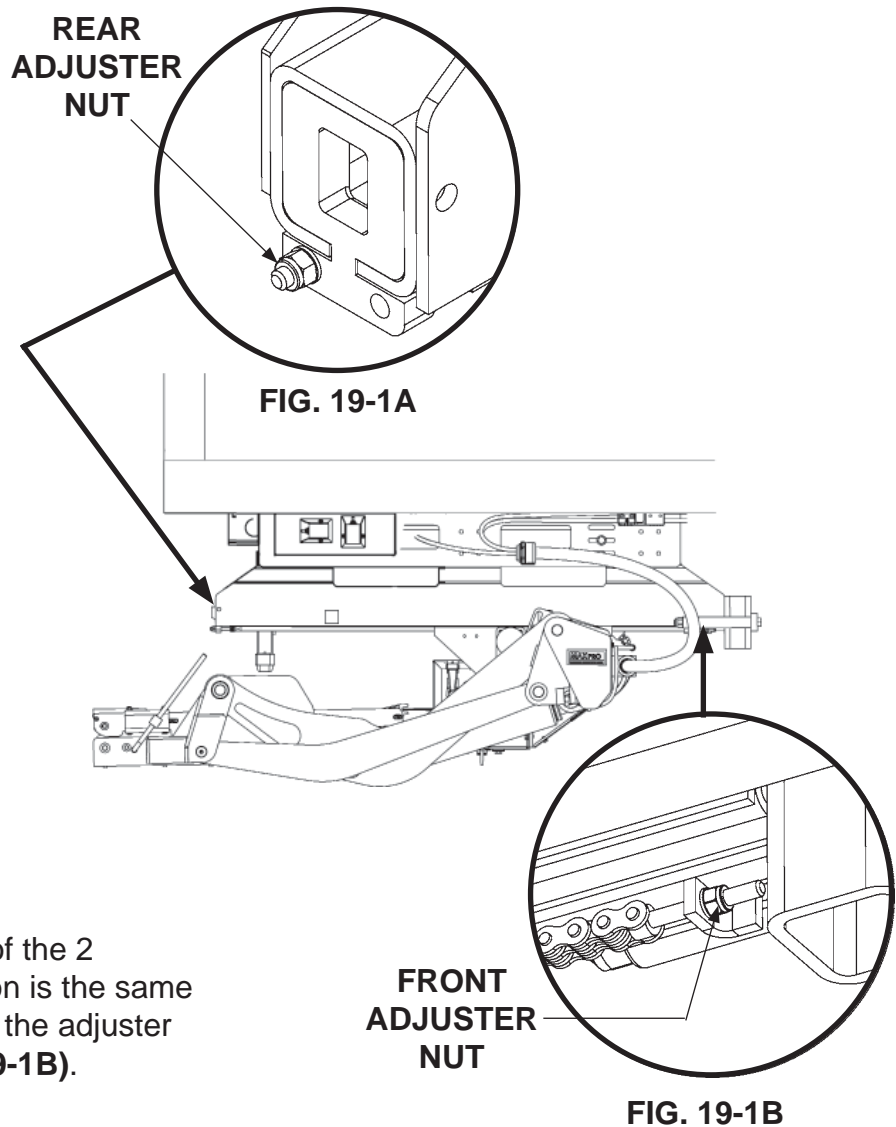

- Measure the distance of the 2 chains. When dimension is the same for both chains, tighten the adjuster nuts (**FIGS. 19-1A & 19-1B**).

- Move the slide frame in and out a few inches and re-measure to make sure the roller plates are even.

**MAXON**

11921 Slauson Ave. Santa Fe Springs, CA. 90670 (800) 227-4116 FAX (888) 771-7713

### DECALS

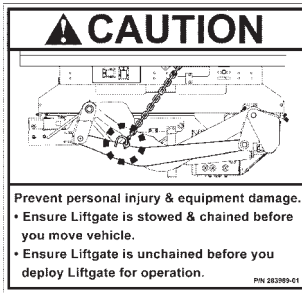

**CAUTION DECAL  
P/N 283989-01**

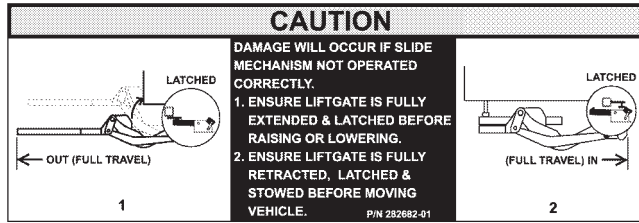

**CAUTION DECAL  
P/N 282682-01**

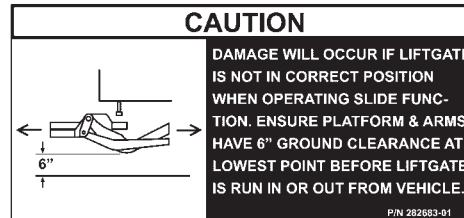

**CAUTION DECAL  
P/N 282683-01**

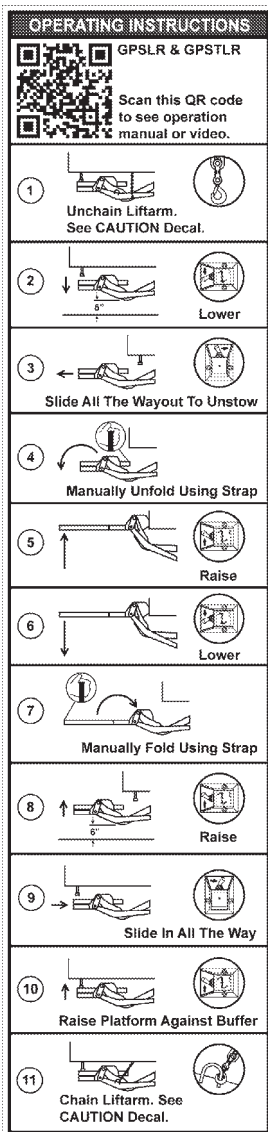

**OPERATION DECAL  
P/N 282681-01**

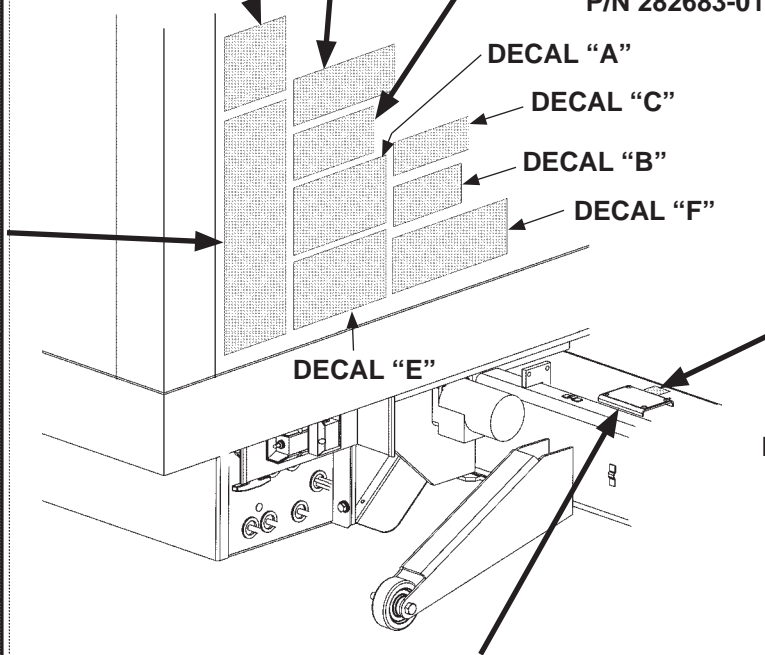

**PARTS QR CODE  
DECAL  
P/N 299349-02**



**SERIAL PLATE (REF)**

**FIG. 20-1**

## SAFETY INSTRUCTIONS

Read all decals and operation manual before operating liftgate.

1. Do not use liftgate unless you have been properly instructed and have read, and are familiar with, the operating instructions.
2. Be certain vehicle is properly and securely braked before using the liftgate.
3. Always inspect this liftgate for maintenance or damage before using it. Do not use liftgate if it shows any sign of damage or improper maintenance.
4. Do not overload
5. Make certain the area in which the platform will open and close is clear before opening or closing the platform.
6. Make certain platform area, including the area in which loads may fall from platform, is clear before and at all times during operation of liftgate.
7. This liftgate is intended for loading and unloading of cargo only. Do not use this liftgate for anything but its intended use.

(A)

## WARNING

Read this information carefully.

- Improper operation of this Liftgate can result in serious personal injury. If you do not have a copy of the operating instructions, please obtain them from your employer, distributor, or lessor before you attempt to operate Liftgate.
- If there are signs of improper maintenance, damage to vital parts, or slippery platform surface, do not use the Liftgate until these problems have been corrected.
- If you are using a pallet jack, be sure it can be maneuvered safely.
- Do not operate a forklift on the platform.
- Do not allow any part of yours or your helper's body to be placed under, within, or around any portion of the moving Liftgate, or its mechanisms, or in a position that would trap them between the platform and the ground or truck when the Liftgate is operated.
- If a helper is riding the platform with you, make sure you are both doing so safely and that you are not in danger of coming in contact with any moving or potentially moving obstacles.
- **USE GOOD COMMON SENSE**
- If load appears to be unsafe, do not lift or lower it.

For a free copy of other manuals that pertain to this model Liftgate, please visit our website at [www.maxonlift.com](http://www.maxonlift.com) or call Customer Service at (800) 227-4116.

(E)



## WARNING

Liftgate hazards can result in crushing or falling.

Keep hands and feet clear of pinch points.

If riding liftgate, make sure load is stable and footing is solid.

(F)

Read and understand all instructions and WARNINGS before use.

## CAUTION

Always stand clear of platform area.

(C)

THE MAXIMUM CAPACITY OF THIS LIFT IS

**3300 POUNDS**

WHEN THE LOAD IS CENTERED ON THE LOAD CARRYING PLATFORM

(B)

GPSLR-33 & GPSTLR-33 ONLY

THE MAXIMUM CAPACITY OF THIS LIFT IS

**4400 POUNDS**

WHEN THE LOAD IS CENTERED ON THE LOAD CARRYING PLATFORM

(B)

GPSLR-44 & GPSTLR-44 ONLY

MODEL	DECAL SHEET P/N	DECAL "B"
GPSLR-33	267431-01	3300 POUNDS
GPSLR-44	267431-02	4400 POUNDS
GPSTLR-33	267431-01	3300 POUNDS
GPSTLR-44	267431-02	4400 POUNDS

TABLE 21-1

# DECALS - Continued

**MAXON**<sup>®</sup>

11921 Slauson Ave. Santa Fe Springs, CA. 90670 (800) 227-4116 FAX (888) 771-7713

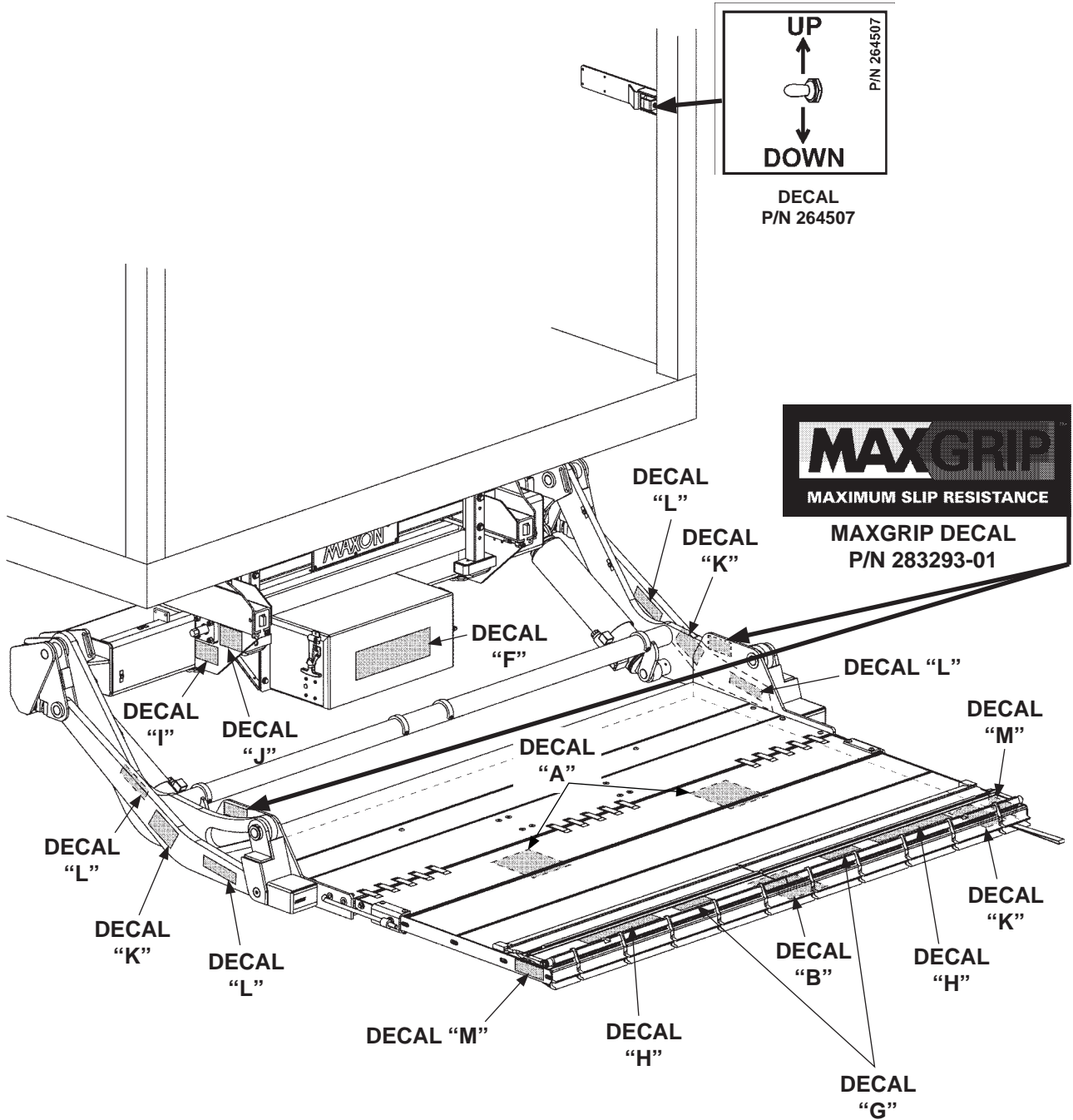

FIG. 22-1

**WARNING**

When unstowing & stowing platform, stay clear of bumpers.

P/N 267432-01 **A**

**WARNING**

To avoid injury stay out of the path where the platform unfolds. Unfold platform from the side.

PIN 267432-01 **B**

**WARNING**

Avoid possible injury & damage to equipment if slider moves under power. Ensure battery is disconnected from liftgate before operating the slider manually.

P/N 267432-01 **J**

**MANUAL SLIDER OPERATION & ACCESS INSTRUCTIONS**

P/N 267432-01 **I**

**WARNING**

Liftgate hazards can result in crushing or falling. Keep hands and feet clear of pinch points. If riding liftgate, make sure load is stable and footing is solid.

Read and understand all instructions and WARNINGS before use.

**F**

**WARNING**

Keep hands clear of pinch points when folding flipover.

**M**

**WARNING**

To avoid possible injury and damage to equipment, never stand on lift arms, parallel arms, or bottom side of platform.

P/N 267432-01 **K**

**WARNING**

Keep hands & feet clear of lifting arms.

PIN 267432-01 **L**

**WARNING**

To prevent personal injury & damaged equipment, ramp must be in retention position when cart is being raised or lowered on platform.

P/N 267432-01 **G**

**1** Push locking arm and pull strap to unlock ramp

**2** Push locking arm and pull ramp

**3** Push locking arm and pull ramp

**4** Push ramp

**5** Push ramp

P/N 267432-01 **H**

DECAL SHEET P/N 267432-01  
FIG. 23-1

# SYSTEM DIAGRAMS

## PUMP & MOTOR SOLENOID OPERATION

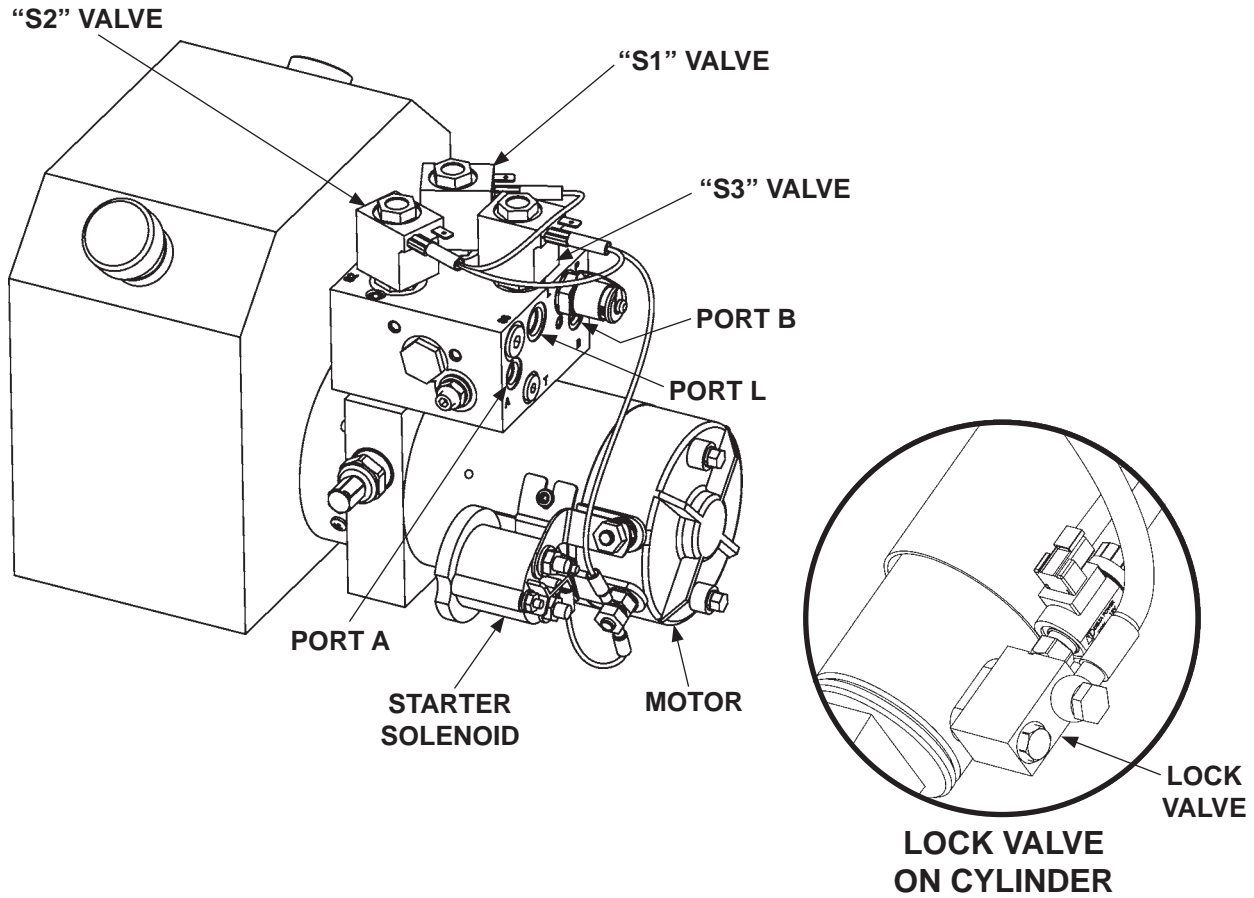

FIG. 24-1

POWER UNIT MOTOR & SOLENOID OPERATION						
TAIL LIFT FUNCTION	PORT	SOLENOID OPERATION (✓ MEANS ENERGIZED)				
		MOTOR	VALVE "S1"	VALVE "S2"	VALVE "S3"	LOCK VALVE
RAISE	L	✓	-	-	-	✓
LOWER	L	-	-	-	✓	✓
SLIDE OPEN	A	✓	-	✓	-	-
SLIDE CLOSED*	B	✓	✓	-	-	-

REFER TO VALVES SHOWN ON HYDRAULIC SCHEMATIC

TABLE 24-1



# HYDRAULIC SCHEMATIC

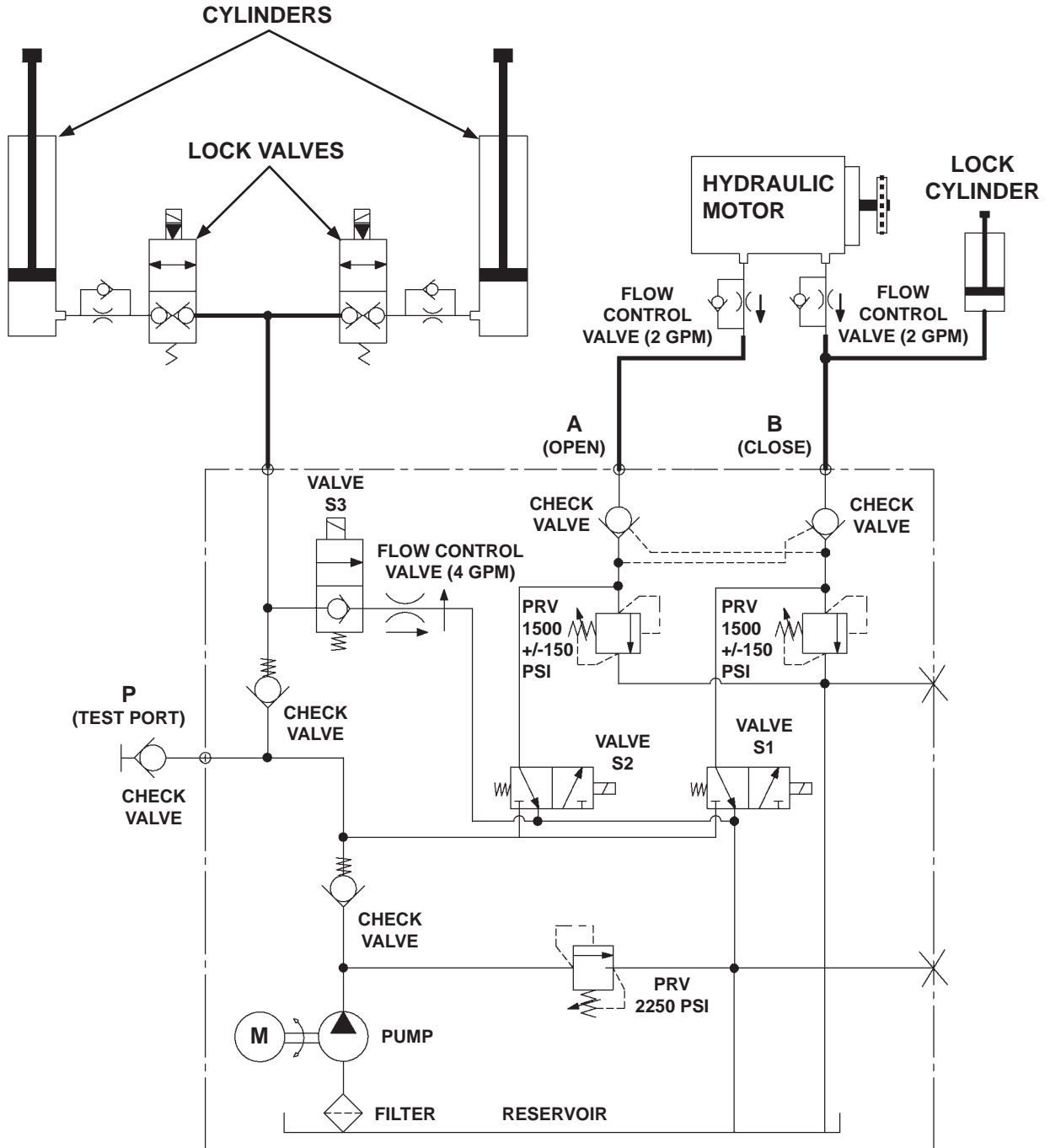

NOTE: PRV (PRESSURE RELIEF VALVE)

FIG. 25-1

# ELECTRICAL SCHEMATIC

**MAXON**  
 11921 Slauson Ave. Santa Fe Springs, CA. 90670 (800) 227-4116 FAX (888) 771-7713

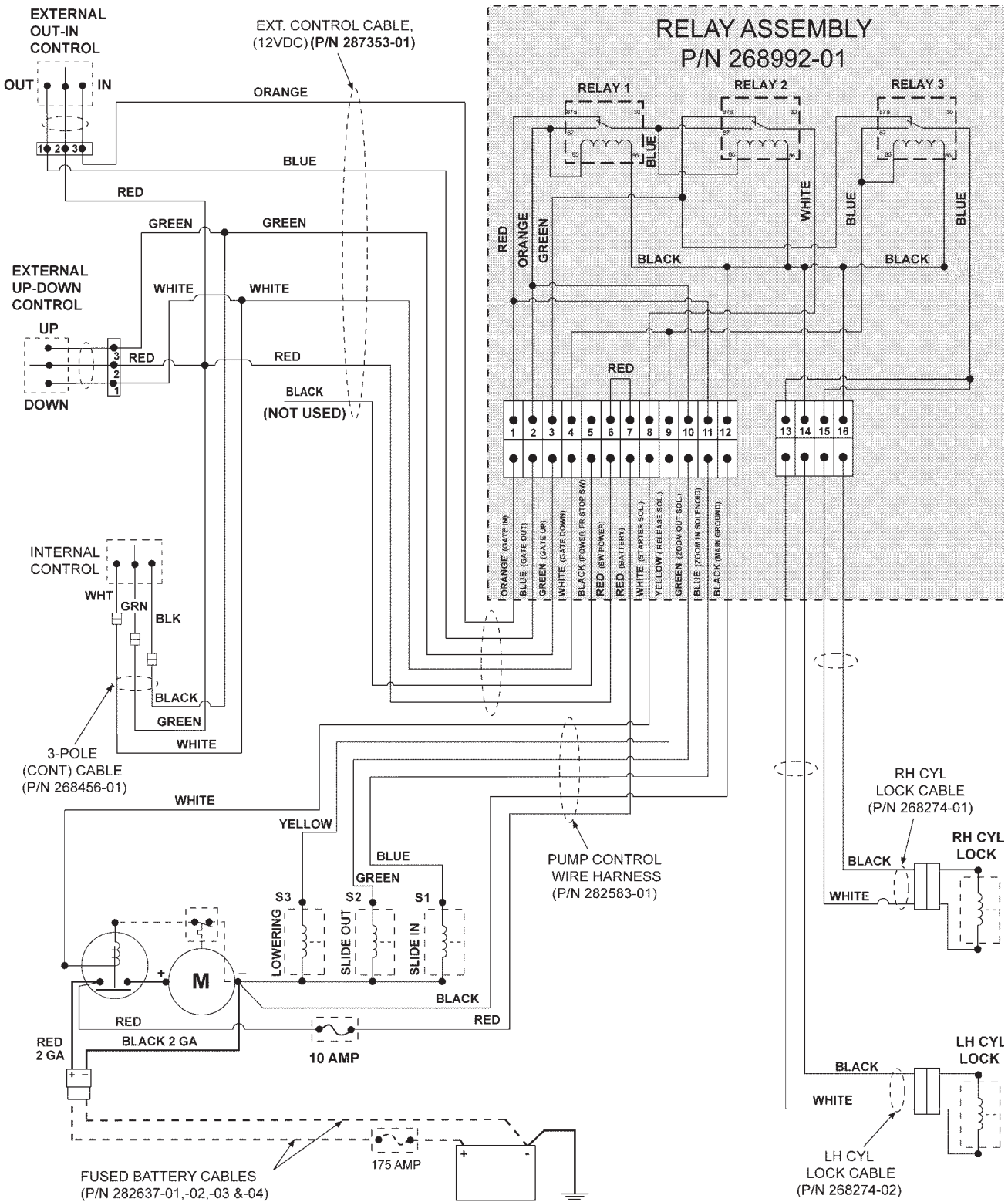

FIG. 26-1

# TROUBLESHOOTING

TO BE PROVIDED IN FUTURE UPDATE

