

# TUK-A-WAY® SERIES

## The TE-25DC Series

# MAXON®

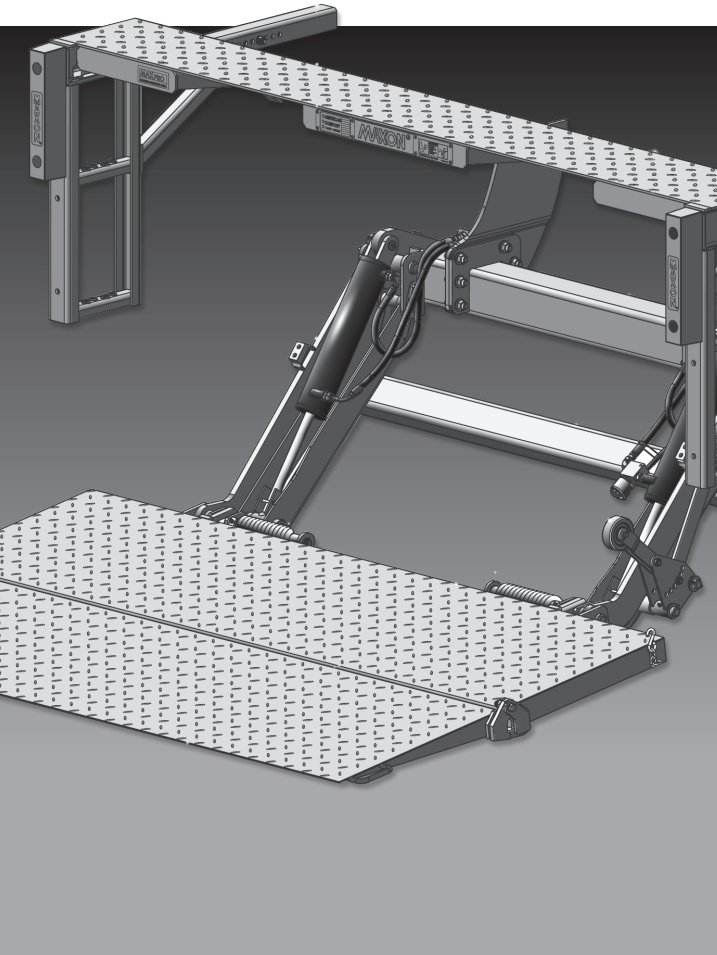

## TE-25DC SPECIFICATIONS

MAXON's TE-25DC liftgate model has taken "standard" to a whole new level. The 2,500 lb, medium-duty, Tuk-A-Way® delivers premium features in a standard tuk.

- Steel, Steel/Aluminum as well as all Aluminum platforms
- Bolted-on extension plate and steps
- Hydraulic locking
- Grease fittings at all critical rotation points
- Low bed height as well as walk ramp ready models available

MODEL	CAPACITY	PLATFORM SIZE	TOTAL WEIGHT	BED HEIGHT
TE-25DC	2,500 Lbs.	48" x 84" ST, ST/AL, AL/AL	990 Lbs - ST 945 Lbs - ST/AL 900 AL/AL	42" Min. Laden 54" Max. Unladen
		52" x 84" ST, ST/AL, AL/AL	1,020 Lbs - ST 975 Lbs -ST/AL 930 AL/AL	54" Max. Unladen
TE-25DC L		48" x 84" ST, ST/AL, AL/AL	990 Lbs - ST 945 Lbs - ST/AL 900 AL/AL	38" Min. Laden 44" Max. Unladen
		52" x 84" ST, ST/AL, AL/AL	1,020 Lbs - ST 975 Lbs -ST/AL 930 AL/AL	40" Min. Laden 44" Max. Unladen
TE-25 DC WR		48" x 84" ST, ST/AL, AL/AL	990 Lbs - ST 945 Lbs - ST/AL 900 AL/AL	42" Min. Laden 54" Max. Unladen
		52" x 84" ST, ST/AL, AL/AL	1,020 Lbs - ST 975 Lbs -ST/AL 930 AL/AL	46" Min. Laden 54" Max. Unladen

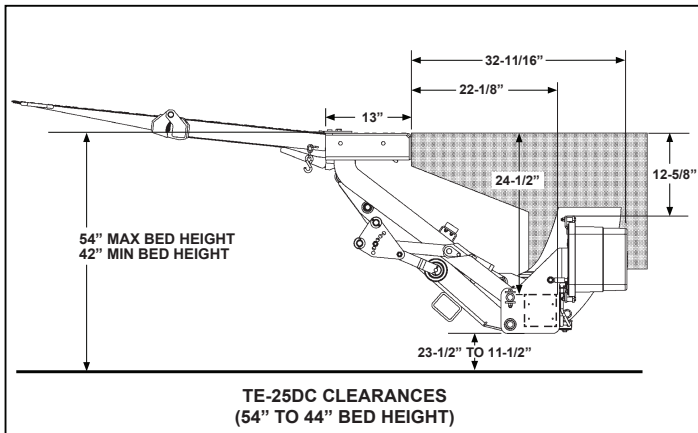

Lift Dimensions and Mounting Requirements  
Refer to install manual for TE-25DC L

"DC L" - Dual Cylinders Low bed height models  
 "DC WR" - Dual Cylinders Walk ramp models  
 "ST" - Steel  
 "AL" - Aluminum

NOTE: Please review appropriate liftgate installation manual for full vehicle and or body requirements to ensure proper fitment.



Maxon Lift Corp. 11921 Slauson Ave., Santa Fe Springs, CA 90670  
 800.227.4116 Fax 888.771.7713, www.maxonlift.com

# TUK-A-WAY® SERIES

## The TE-25DC Series

# MAXON®

### Optional Features

- Hand held control
- Cab Cut-off
- Power down
- Single or Dual Cart stops (ST/AL and AL/AL platforms only)
- Galvanized finish

### Loadable Platform Space with Cart Stops Deployed

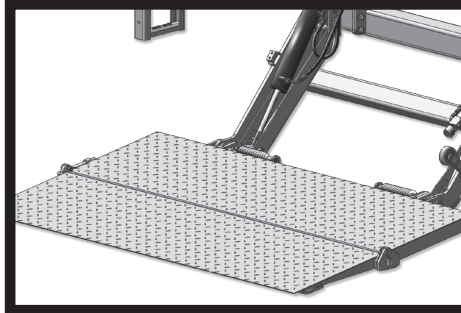
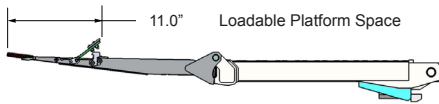

### Large Wedge-Type Platform Design

The TE-25DC features large 48" x 84" and 52" x 84" wedge-type steel, steel/aluminum, or aluminum/aluminum platforms. The ST/AL and AL/AL platforms come optional with single or dual cart stops. The wedge design allows smooth transition of load on and off the platform.

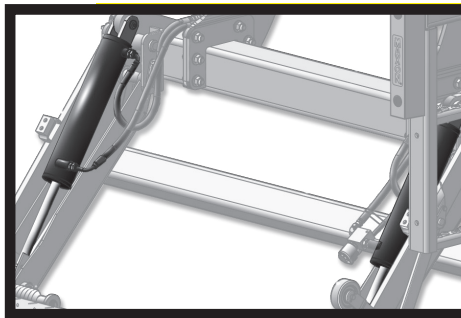

### Twin Cylinder Design

The TE-25DC features a twin cylinder, mid-arm design resulting in great performance and stability.

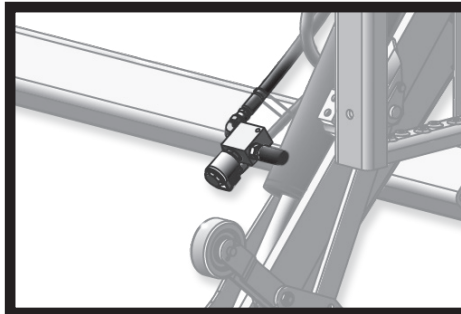

### Hydraulic Locking

The TE-25DC features a hydraulic lock valve that takes operator involvement out of the equation. As soon as the control button is released the gate is always securely locked.

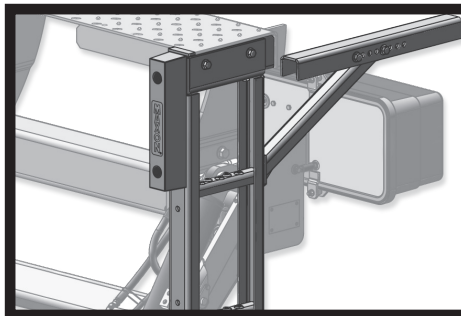

### Bolt-On Steps & Extension Plate

The steps and extension plates were strategically designed to bolt-on in order to avoid welding on the gate that would affect the factory paint. The steps were also designed as an integral part of the gate that would easily allow for them to be exchanged in case of dock damage.

Distributed by:



### MAXPRO® Paint or GALVANIZED Finish

This patented, Maxon exclusive paint process has a tough polyurea top coat and an AL rich primer that combat corrosion and keep the liftgate looking like new. For even more corrosion protection, the TE-25DC is also available in a galvanized finish.

M-230-0219



Maxon Lift Corp. 11921 Slauson Ave., Santa Fe Springs, CA 90670  
800.227.4116 Fax 888.771.7713, [www.maxonlift.com](http://www.maxonlift.com)