

INSTRUCTIONS, RA ROLLER REPLACEMENT

⚠ WARNING

Installing and maintaining a liftgate can expose you to chemicals, including lead, which are known to the State of California to cause cancer and birth defects or other reproductive harm. To minimize exposure, install and maintain liftgate in a well-ventilated area and wear proper Personal protective equipment (PPE). For more information go to www.P65Warnings.ca.gov.

CAM FOLLOWER KIT (2" ROLLER), P/N 295973-02

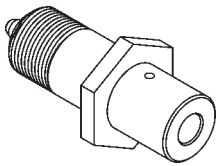

PIN, CAM FOLLOWER,
1-1/8"-12 THREAD
P/N 295974-02
QTY. 4

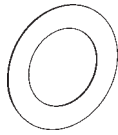

TEFLON WASHER,
1-3/4" O.D.
P/N 903463-02
QTY. 4

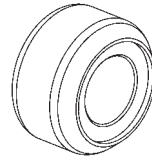

ROLLER, 1" ID,
2" OD
P/N 295975-02
QTY. 4



END CAP, ROLLER
P/N 295962-01
QTY. 4

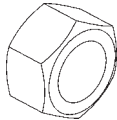

HEX NUT, THIN, 1-1/8"-12
P/N 903158-01
QTY. 4

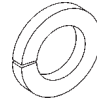

LOCK WASHER, SPLIT, 1-1/8"
P/N 903457-01
QTY. 2



NORD-LOCK WASHER, 1"/M30
P/N 903435-12
QTY. 2

CAM FOLLOWER KIT (1-7/8" ROLLER), P/N 295973-01

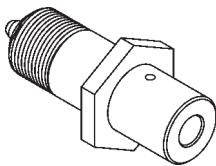

PIN, CAM FOLLOWER,
1"-14 THREAD
P/N 295974-01
QTY. 4



TEFLON WASHER, 1-3/4" OD
P/N 903463-02
QTY. 4

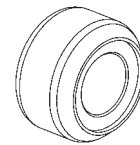

ROLLER, 1" ID, 1-7/8" OD
P/N 295975-01
QTY. 4



END CAP, ROLLER
P/N 295962-01
QTY. 4

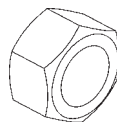

HEX NUT, THIN, 1"-14
P/N 903157-01
QTY. 4

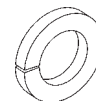

LOCK WASHER, SPLIT, 1"
P/N 903450-01
QTY. 4

Estas instrucciones están disponibles en español a partir de la página 15.

1. Remove limit switch lever assembly by removing roll pin (**FIG. 2-1**).



LEVER
(REMOVE)

ROLL PIN
(REMOVE)

**REMOVING LIMIT SWITCH LEVER FROM
RH SIDE VEHICLE MOUNT
FIG. 2-1**

NOTE: In and out, Front and back are referenced from standing at ramp end of platform on the liftgate.

2. Refer to **Operation Manual** for detailed operating instructions. Slide out Liftgate all the way (**FIGS. 3-1 and 3-2**). Then, lower platform on to pallet jack or forklift, to support platform (**FIG. 3-3**).

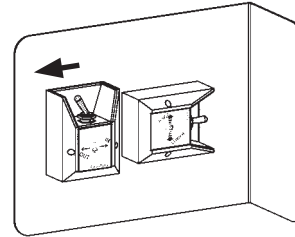

OUT CONTROL SWITCH
FIG. 3-1

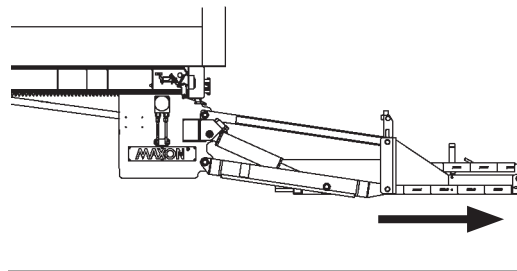

LIFTGATE TRAVELS TO FRONT STOPS
FIG. 3-2



PLATFORM RUN ALL THE WAY PUT OUT & SUPPORTED BY PALLET JACK
FIG. 3-3

3. Remove RH-front stop block
(FIG. 4-1). Repeat for LH front
stop block.

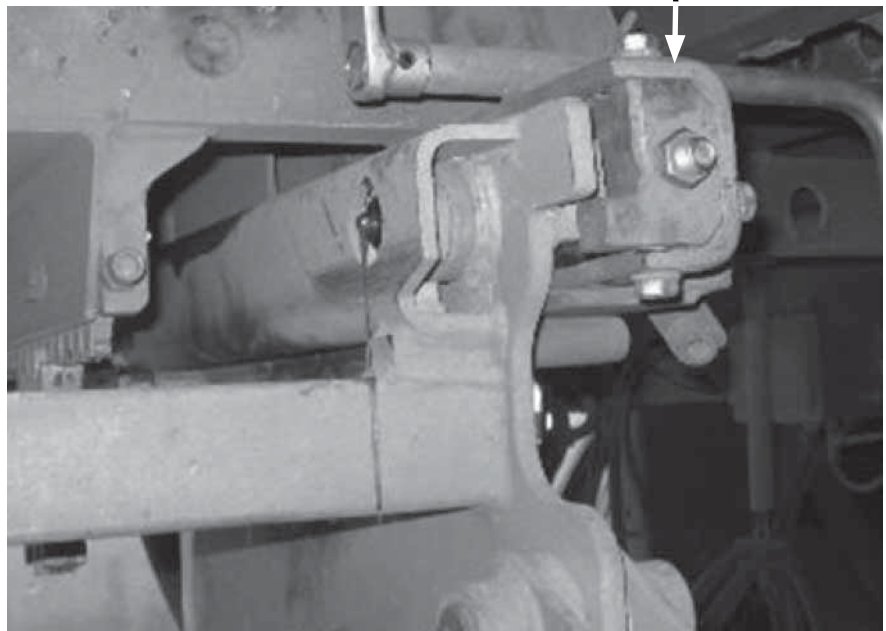
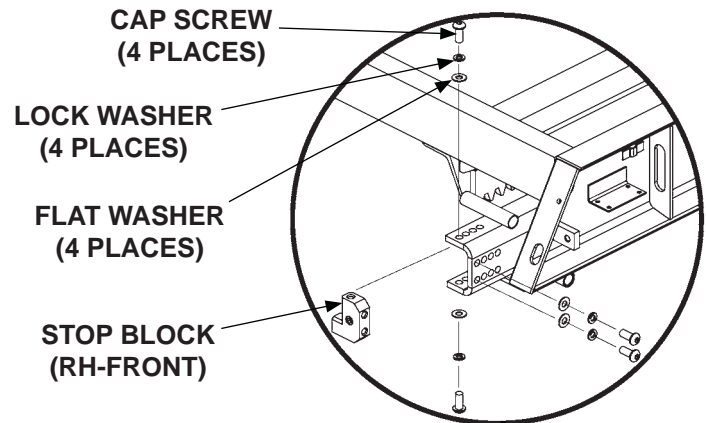

**REMOVING RH-FRONT STOP BLOCK
FIG. 4-1**

NOTE: When the drive pinion gears disengage from the drive racks, pull the slider frame out manually the last few inches, with pallet jack or forklift.

4. To access the front RH and LH rollers, tap the **OUT** control switch (**FIG. 5-1**) to position slider assembly out approximately 6" beyond the usual front stop position (**FIG. 5-2**).

5. Remove hex nut, lock washer, axle pin and roller on RH side (**FIG. 5-2**). Discard these old parts

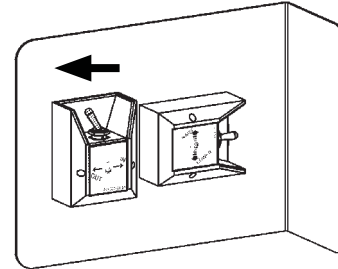

OUT CONTROL SWITCH
FIG. 5-1

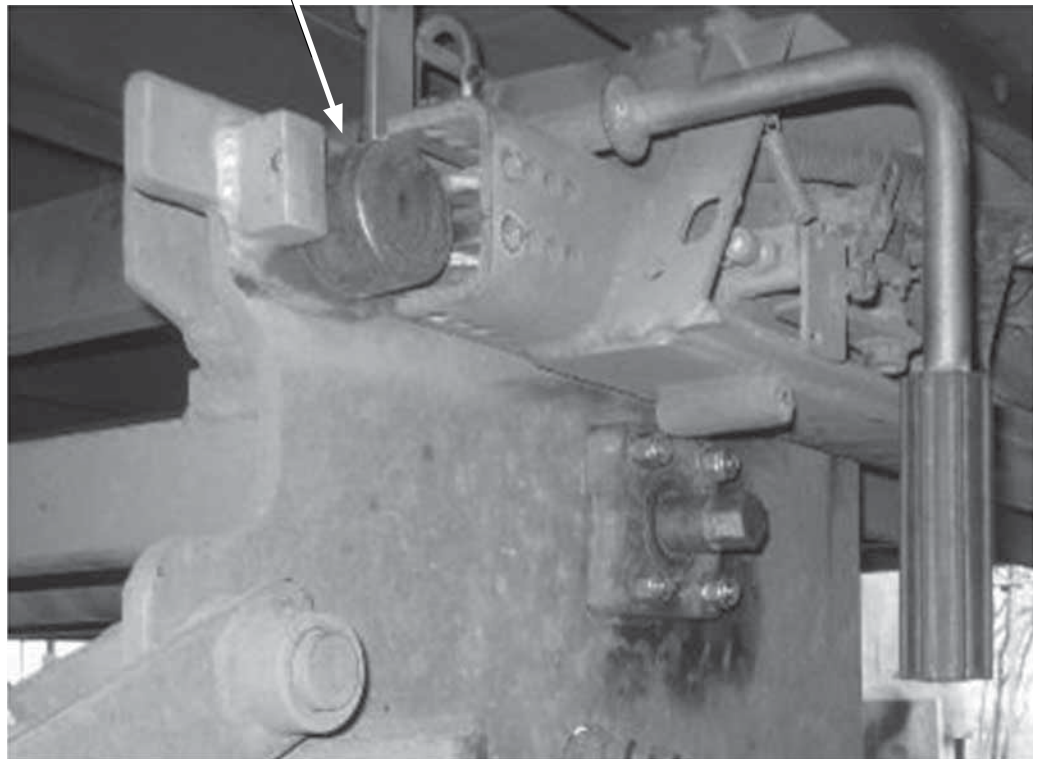
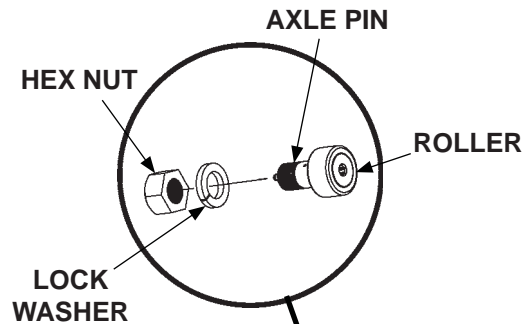

ACCESSING & REMOVING RH FRONT ROLLER
FIG. 5-2

6. Install new cam follower pin with nut and nord-lock washer (**FIG. 6-1B**). Torque pin to **140 lb-ft**.

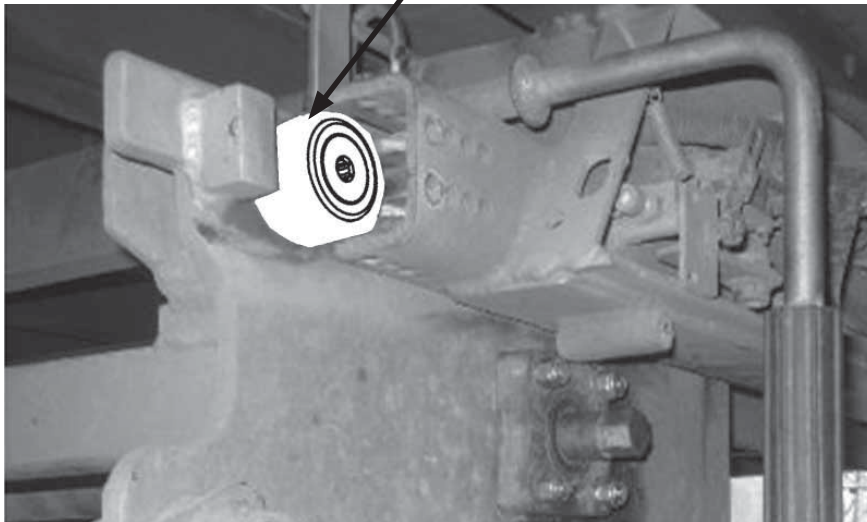
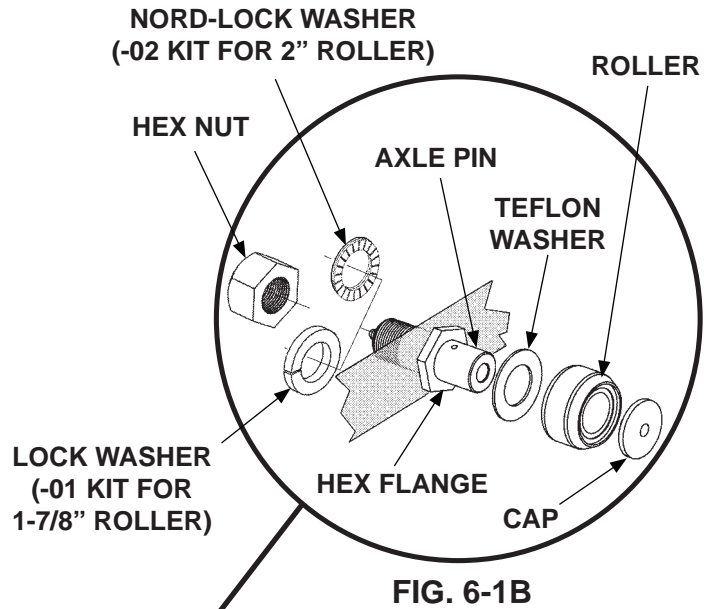

INSTALLING NEW AXLE PIN & ROLLER
FIG. 6-1A

7. Place teflon washer on pin (**FIG. 6-1A**). Next, place roller on pin (**FIGS. 6-1A**). Then, insert plastic cap on the axle pin and roller.
8. Repeat steps 5 through 7 for LH front roller.

NOTE: Push the slider assembly in manually, with pallet jack or forklift, to reengage drive pinion gears with the drive racks.

9. Move slider assembly in, until front rollers are in the tracks on mounting frame, and the drive rack and pinion are engaged. Then, hold in-out switch in the **IN** position (**FIG. 7-1**), to let slider frame travel all the way to the rear stops (**FIG. 7-2**).

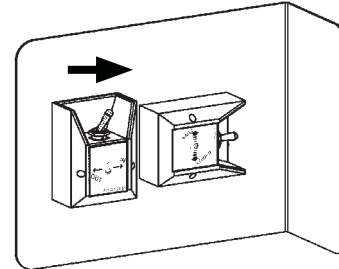

IN CONTROL SWITCH
FIG. 7-1

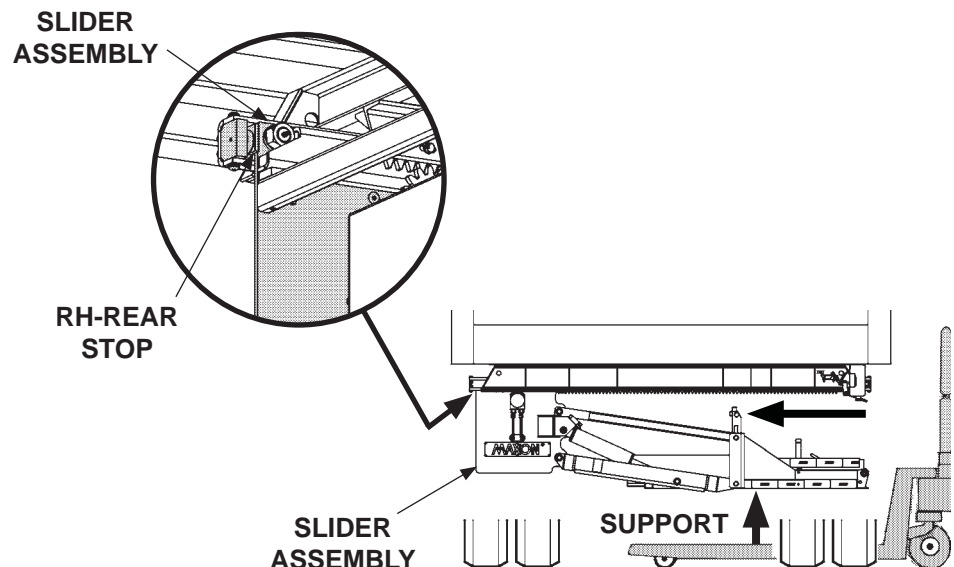

SLIDING PLATFORM IN
FIG. 7-2

10. Reinstall RH-front stop block (**FIG. 8-1**).
Repeat for LH-front stop block.

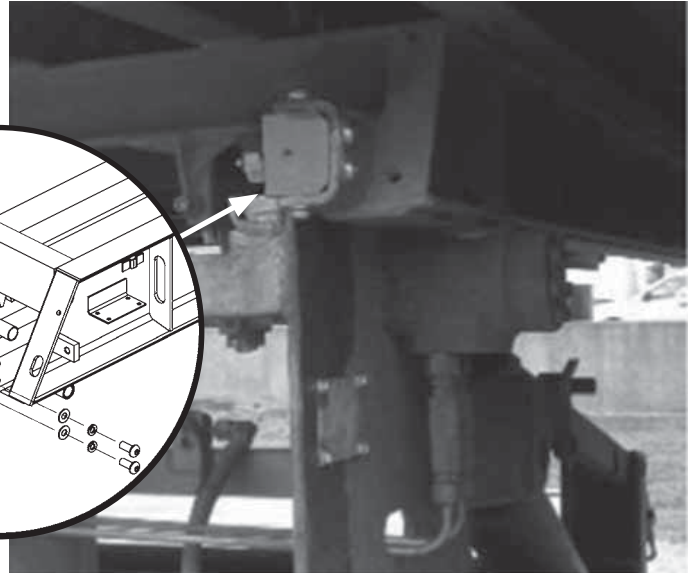
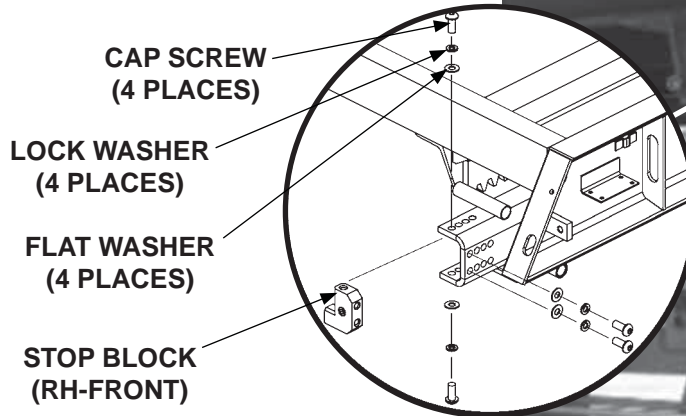

**SLIDER ASSEMBLY ALL THE WAY IN &
FRONT STOP BLOCKS REINSTALLED
FIG. 8-1**

11. Pump EP chassis grease in the lube fitting on the end of the axle pin (**FIG. 8-2**). Stop when grease starts to ooze from roller. Wipe off excess grease with a clean lint-free cloth. Repeat for LH-front roller.

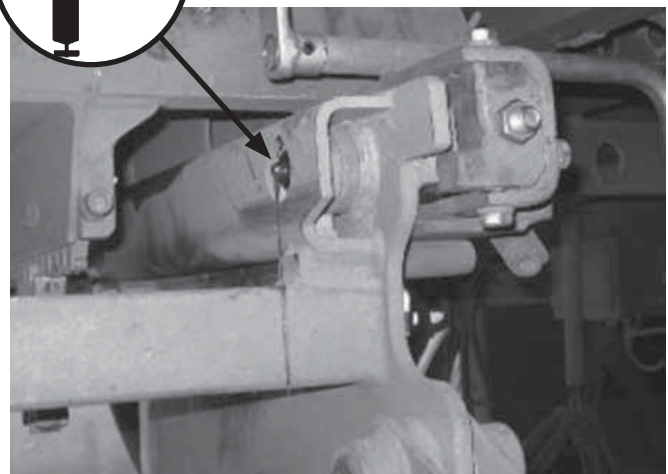

**GREASING NEW ROLLER
FIG. 8-2**

12. Reinstall limit switch lever assembly (**FIG. 9-1**). Secure lever by inserting roll pin.

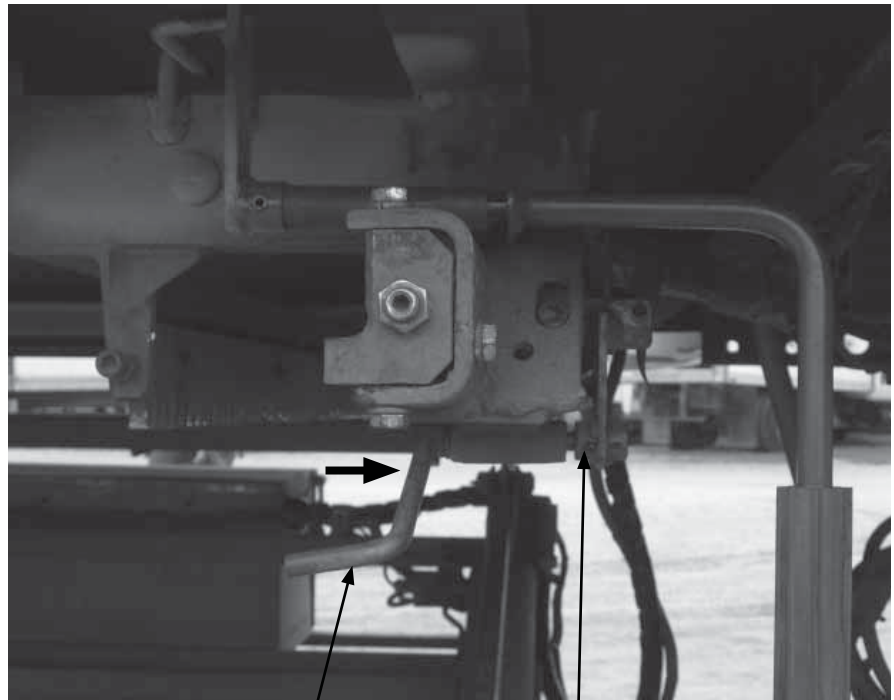

LEVER
(REINSERT)

ROLL PIN
(REINSERT)

**REINSTALLING LIMIT SWITCH LEVER ON
RH SIDE VEHICLE MOUNT
FIG. 9-1**

13. Remove RH-rear stop block
(**FIG. 10-1**). Repeat for LH-
rear stop block.

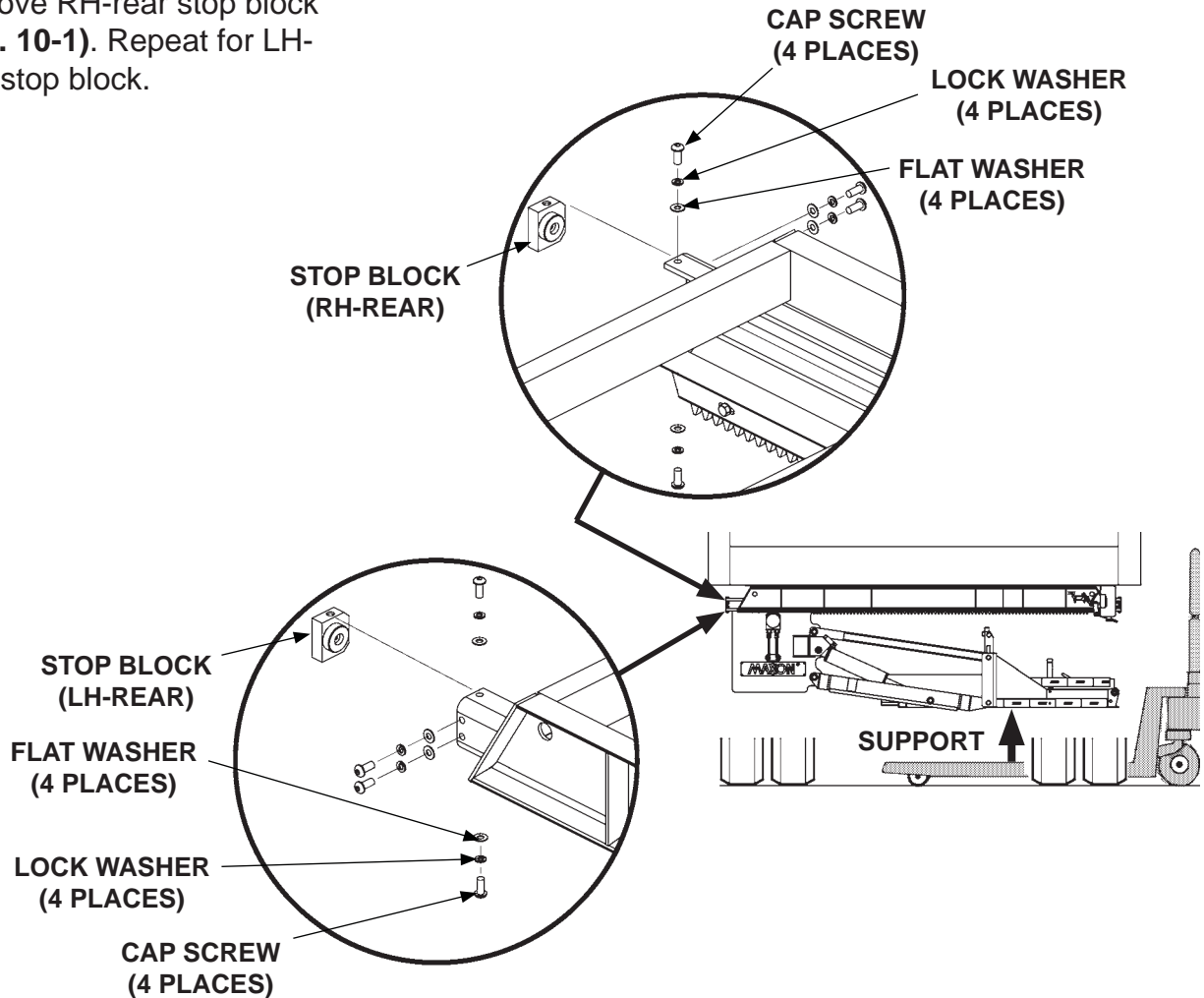

**REMOVING REAR STOP BLOCKS
(REAR OF VEHICLE SHOWN, SLIDER ALL THE WAY IN)
FIG. 10-1**

NOTE: When the drive pinion gears disengage from the drive racks, push the slider frame out the rear, manually the last few inches, with pallet jack or forklift.

14. To access the RH and LH rollers, tap the **IN** control switch (**FIG. 11-1**) to position slider assembly approximately 6" beyond the usual rear stop position.

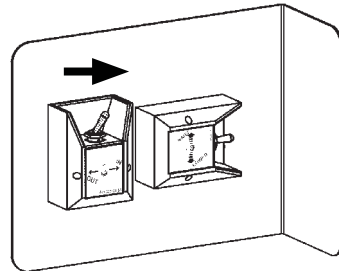

IN CONTROL SWITCH
FIG. 11-1

15. Remove hex nut, lock washer, axle pin and roller on RH-rear of slider assembly (**FIG. 11-2**). Repeat for LH-rear roller. Discard these old parts

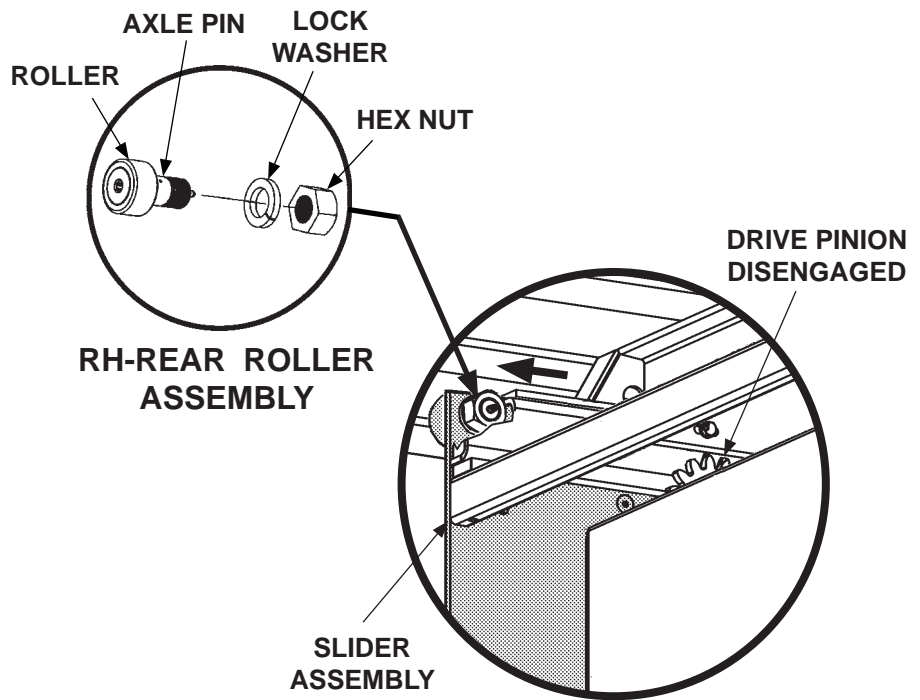

GAINING ACCESS TO REMOVE
RH-REAR ROLLER
FIG. 11-2

16. Install new cam follower pin with nut and split lock washer (**FIG. 12-1**). Torque pin to **140 lb-ft**.

17. Place teflon washer on pin (**FIG. 12-1**). Next, place roller on pin (**FIG. 12-1**). Then, insert plastic cap on the axle pin and roller.

18. Repeat steps 15 through 17 for LH-front roller.

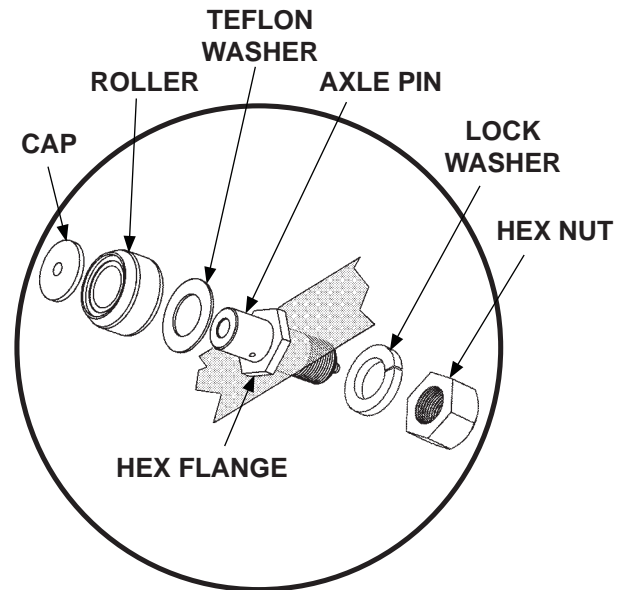

**INSTALLING CAM FOLLOWER
ROLLER KITS
FIG. 12-1**

NOTE: Push the slider assembly in manually, with pallet jack or forklift, to reengage drive pinion gears with the drive racks.

19. Move slider assembly to reinsert rear rollers in tracks on mounting frame, and to engage the drive rack and pinion (**FIGS. 13-2A and 13-2B**). When the drive rack and pinion are engaged, tap the in-out switch to **OUT** position (**FIG. 13-1**), until tracks are clear to reinstall rear stop blocks (**FIG. 13-2B**).

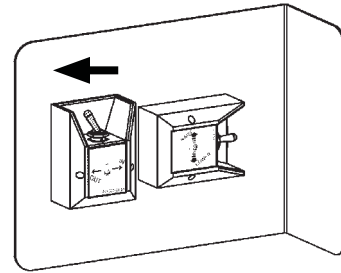

OUT CONTROL SWITCH
FIG. 13-1

20. Reinstall RH-rear stop block (**FIG. 13-2C**). Repeat for LH-rear stop block (**FIG. 13-2D**).

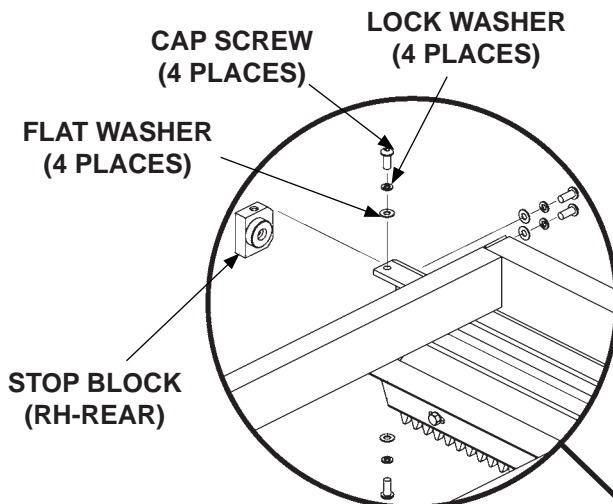

FIG. 13-2C

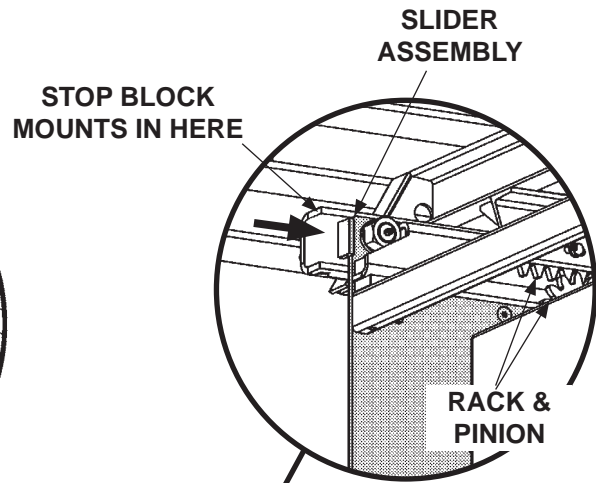

FIG. 13-2B

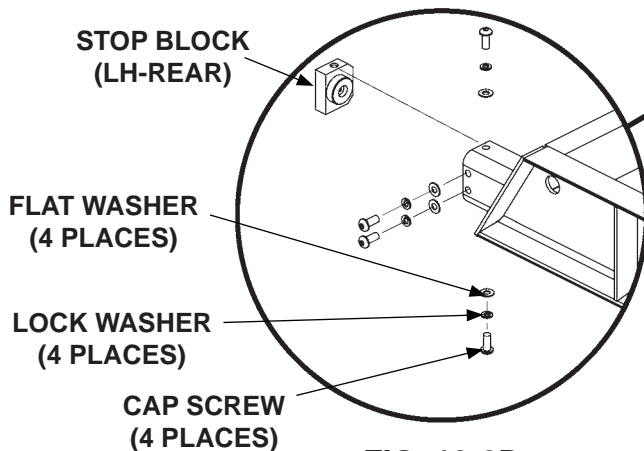
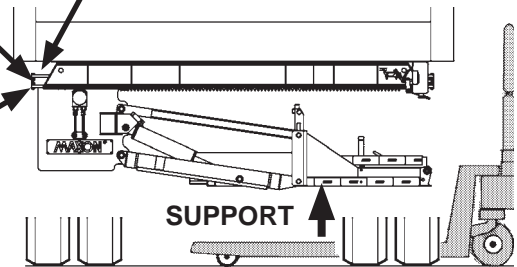
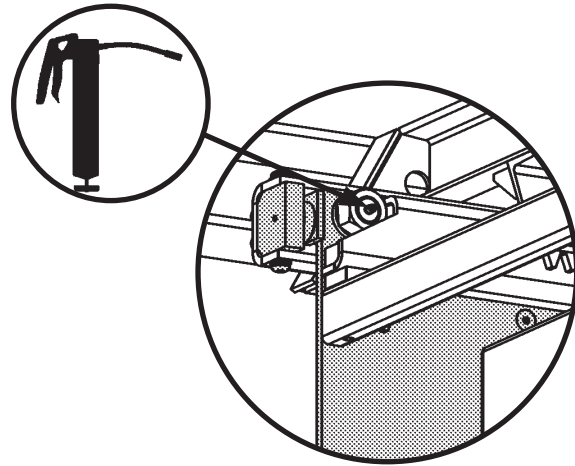

FIG. 13-2D



REINSTALLING REAR STOP BLOCKS
(REAR OF VEHICLE SHOWN)
FIG. 13-2A

21. Pump EP chassis grease in the lube fitting on the end of the axle pin (**FIG. 14-1**). Stop when grease starts to ooze from roller. Wipe off excess grease with a clean lint-free cloth. Repeat for LH-front roller.



GREASING ROLLERS
FIG. 14-1

22. Move pallet jack or forklift clear of the Liftgate and vehicle.

23. Check operation with new rollers by running the slider assembly all the way out and all the way in (**FIG. 14-2**). Refer to **Operation Manual** for detailed operating instructions.

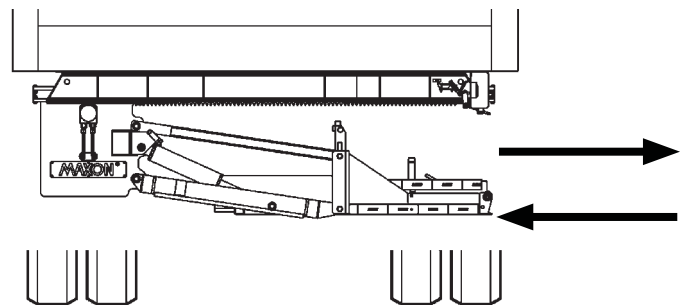

CHECK LIFTGATE OPERATION
FIG. 14-2

INSTRUCCIONES PARA REEMPLAZAR RODILLOS DEL RA

⚠ ADVERTENCIA

Instalar y dar mantenimiento al elevador hidráulico puede exponerle a químicos, incluyendo plomo, los cuales pueden causar cáncer y anomalías congénitas u otros daños reproductivos conocidos para el estado de California. Para minimizar su exposición, instale y mantenga el elevador hidráulico en un área ventilada y utilice **Equipo Protección Personal (PPE, por sus siglas en inglés)**. Para obtener más información consulte www.P65Warnings.ca.gov.

KIT DE SEGUIDOR DE LEVA (RODILLO DE 2"), N/P 295973-02

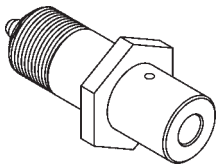

EJE DE SEGUIDOR DE LEVA, 1-1/8"-12, ROSCADO
N/P 295974-02
CANT. 4

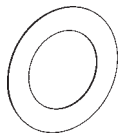

ARANDELA DE TEFLÓN, D.e. 1-3/4"
N/P 903463-02
CANT. 4

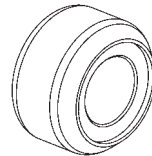

RODILLO, 1" D.i., 2" D.e.
N/P 295975-02
CANT. 4



TAPA DE RODILLO
N/P 295962-01
CANT. 4

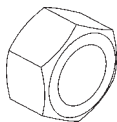

TUERCA HEX. DELGADA, 1-1/8"-12
N/P 903158-01
CANT. 4

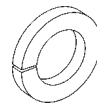

ARANDELA DE PRESIÓN, 1-1/8"
N/P 903457-01
CANT. 2



ARANDELA DE BLOQUEO, 1"/ M30
N/P 903435-12
CANT. 2

KIT DE SEGUIDOR DE LEVA (RODILLO DE 1-7/8"), N/P 295973-01

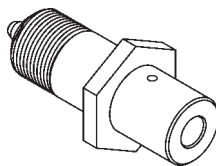

EJE DE SEGUIDOR DE LEVA, 1"-14, ROSCADO
N/P 295974-01
CANT. 4



ARANDELA DE TEFLÓN, 1-3/4" D.e.
N/P 903463-02
CANT. 4

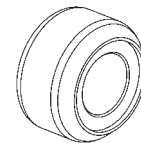

RODILLO, 1" D.i., 1-7/8" D.e.
N/P 295975-01
CANT. 4



TAPA DE RODILLO
N/P 295962-01
CANT. 4

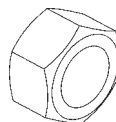

TUERCA HEX. DELGADA, 1"-14
N/P 903157-01
CANT. 4



ARANDELA DE PRESIÓN, 1"
N/P 903450-01
CANT. 4

1. Retire la palanca del interruptor de límite quitando el pasador de rodillo (FIG. 16-1).



PALANCA
(RETIRAR)

PASADOR
(RETIRAR)

**RETIRAR PALANCA DEL INTERRUPTOR DE LÍMITE AL
LADO DERECHO EN EL SOPORTE DEL VEHÍCULO
FIG. 16-1**

NOTA: Adentro y afuera, al frente y detrás se toman desde un punto de vista parado al extremo de la rampa en la plataforma del elevador.

2. Consulte el **Manual de Operación** para ver las instrucciones de operación detalladamente. Extienda por completo la plataforma del elevador (**FIGS. 17-1 y 17-2**). Después, baje la plataforma hasta que quede apoyada en una transpaleta o montacargas (**FIG. 17-3**).

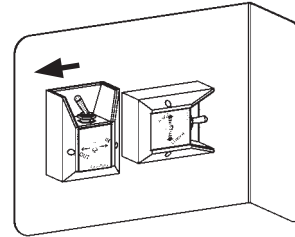

INTERRUPTOR DE CONTROL (AFUERA)
FIG. 17-1

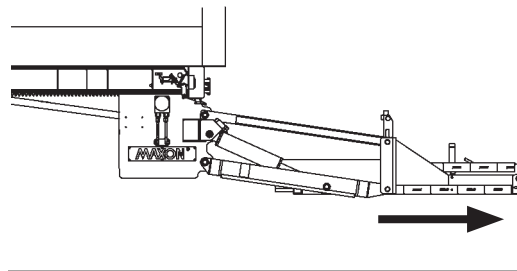

EL ELEVADOR SE EXTIENDE AL TOPE FRONTAL
FIG. 17-2



PLATAFORMA EXTENDIDA POR COMPLETO Y APOYADA EN TRANSPALETA
FIG. 17-3

3. Retire el tope frontal derecho (FIG. 18-1). Repita instrucción para el tope frontal izquierdo.

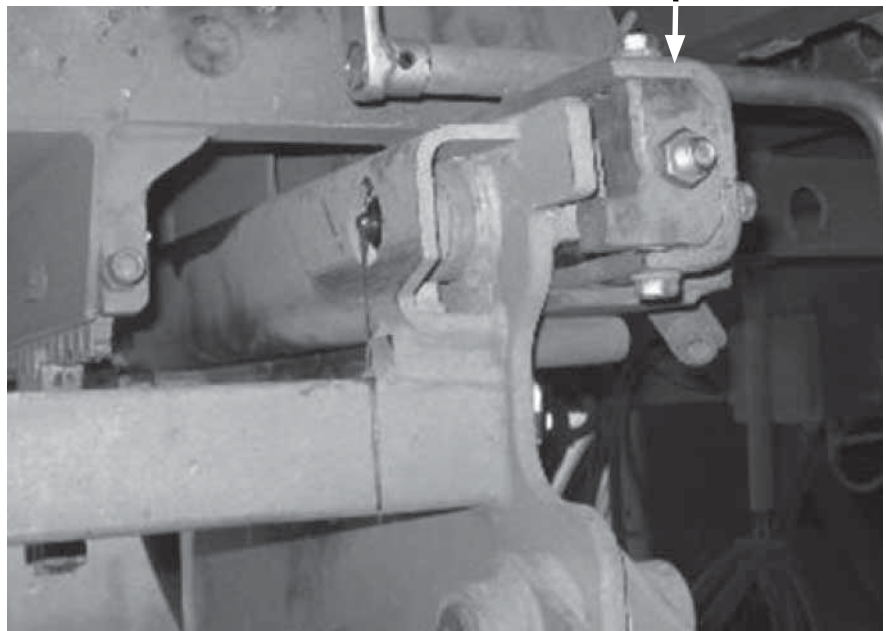
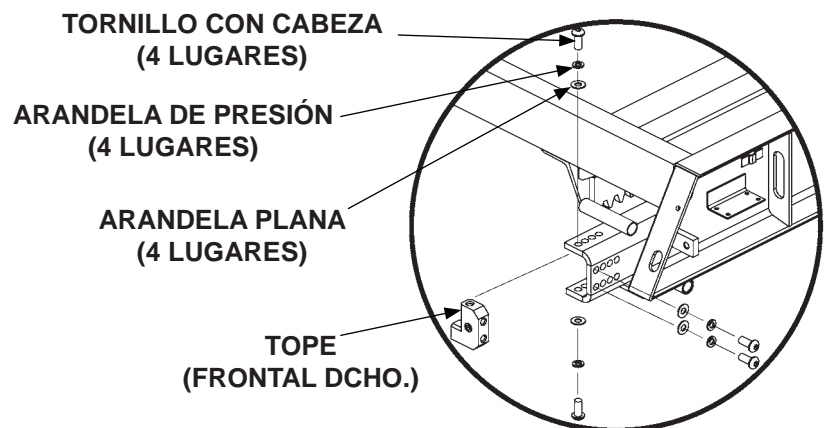

RETIRAR TOPE FRONTAL DERECHO
FIG. 18-1

NOTA: Cuando los engranajes de piñón se desensamblen de la cremallera, con una transpaleta o montacargas tire del marco deslizador hacia afuera para sacar las últimas pulgadas.

4. Para tener acceso a los rodillos derecho e izquierdo, accione el interruptor de control a la posición de **Afuera / OUT (FIG. 19-1)** para posicionar el ensamble deslizador a aproximadamente **6" [15.2 cm]** de la posición de parada frontal (**FIG. 19-2**).

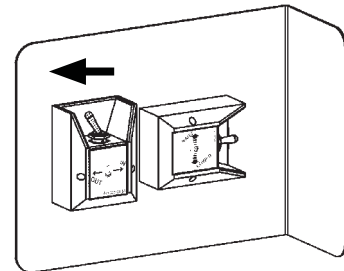

INTERRUPTOR DE CONTROL (AFUERA)
FIG. 19-1

5. Retire y deseche la tuerca hexagonal, arandela de presión, eje y rodillo del lado derecho (**FIG. 19-2**).

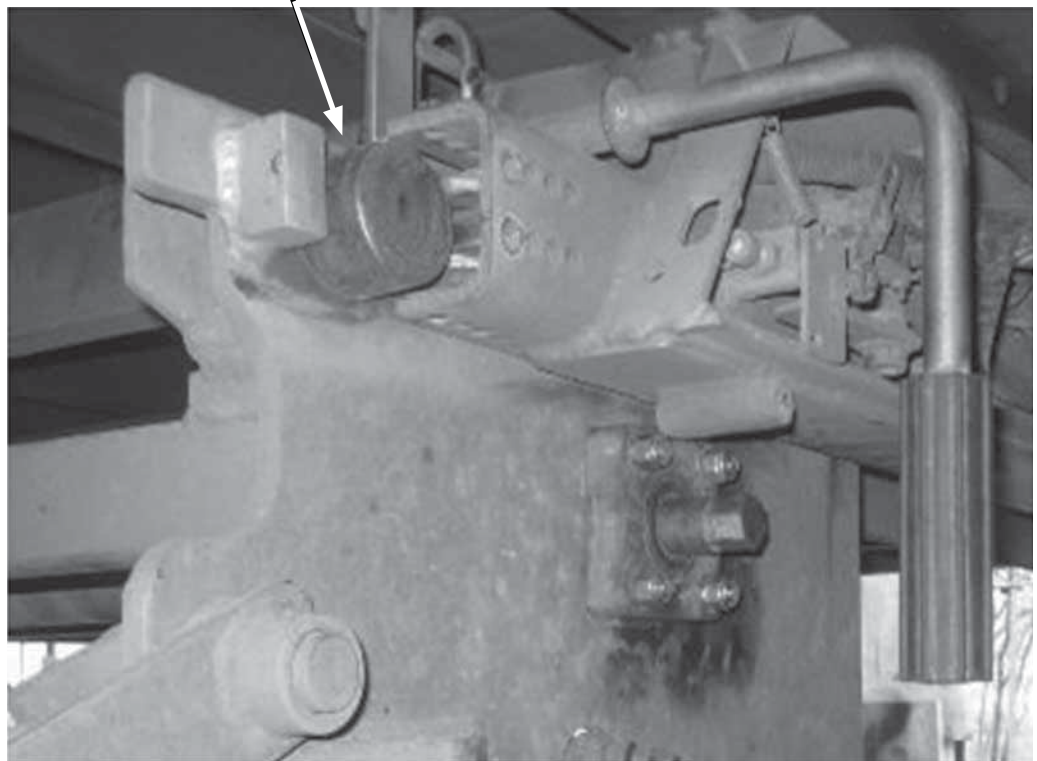
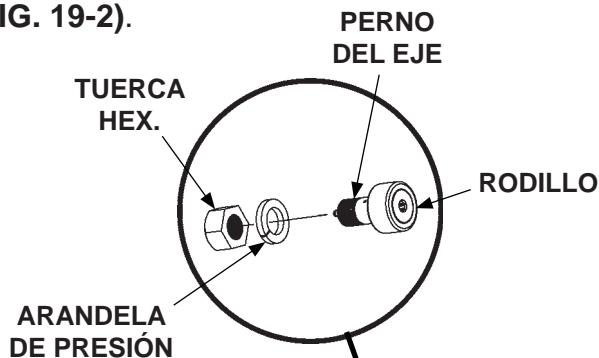

ACCEDER Y RETIRAR RODILLO FRONTAL DERECHO
FIG. 19-2

6. Instale el nuevo eje del seguidor de leva con su respectiva tuerca y arandela de bloqueo (**FIG. 20-1B**). Aplique un torque de **140 lb-ft [189.81 N·m]**.

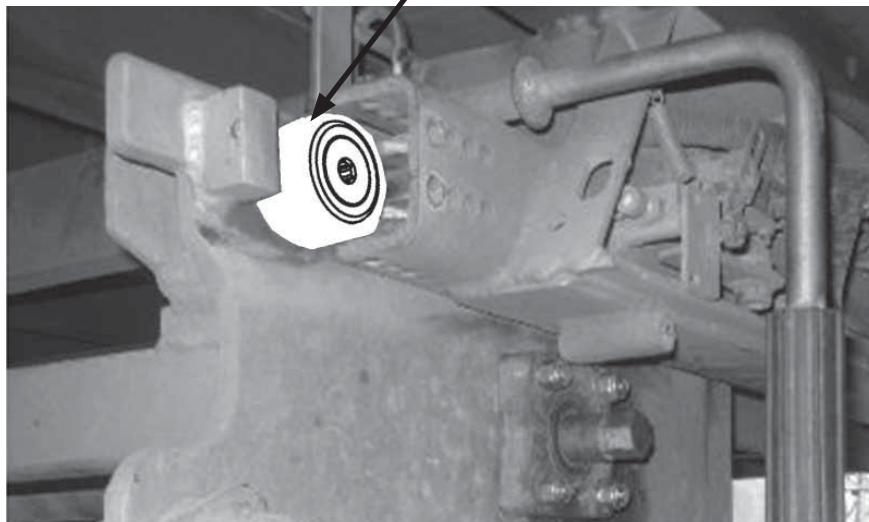
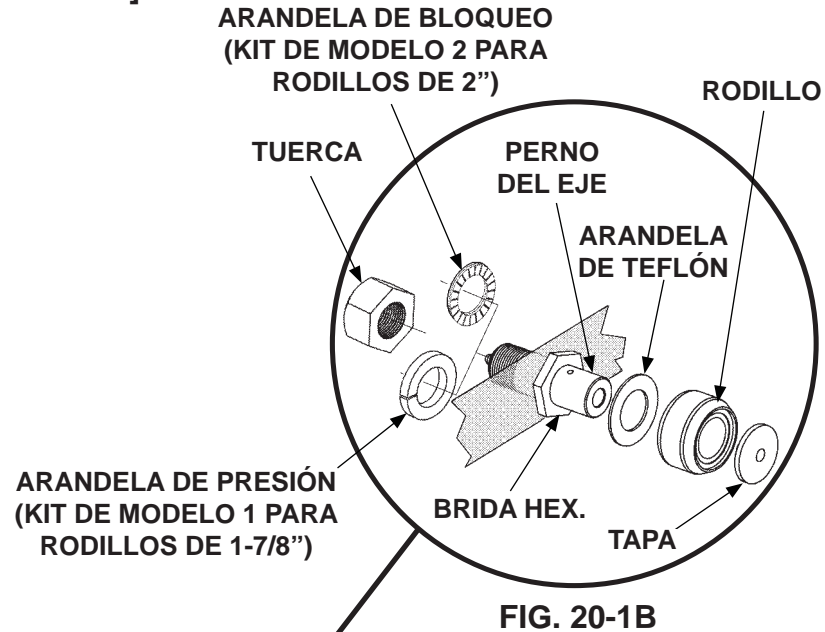

INSTALAR NUEVO EJE Y RODILLO
FIG. 20-1A

7. Coloque una arandela de teflón en el eje y después coloque el rodillo (**FIG. 20-1A**). Al final, ponga la tapa al rodillo del eje.
8. Repita los pasos 5 a 7 para instalar el rodillo frontal izquierdo.

NOTA: Empuje el ensamblaje deslizador manualmente con una transpaleta o montacargas, para reensamblar los piñones con la cremallera.

9. Mueva hacia adentro el ensamblaje deslizador, hasta que los rodillos frontales estén en el riel del marco deslizador y el piñón este ensamblado a la cremallera. Después, accione el interruptor de control adentro-afuera hacia la posición **Adentro / IN (FIG. 21-1)**, para que el marco deslizador se extienda hasta los topes posteriores (**FIG. 21-2**).

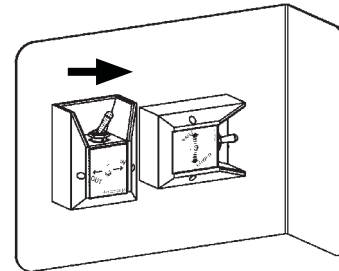

INTERRUPTOR DE CONTROL (ADENTRO)
FIG. 21-1

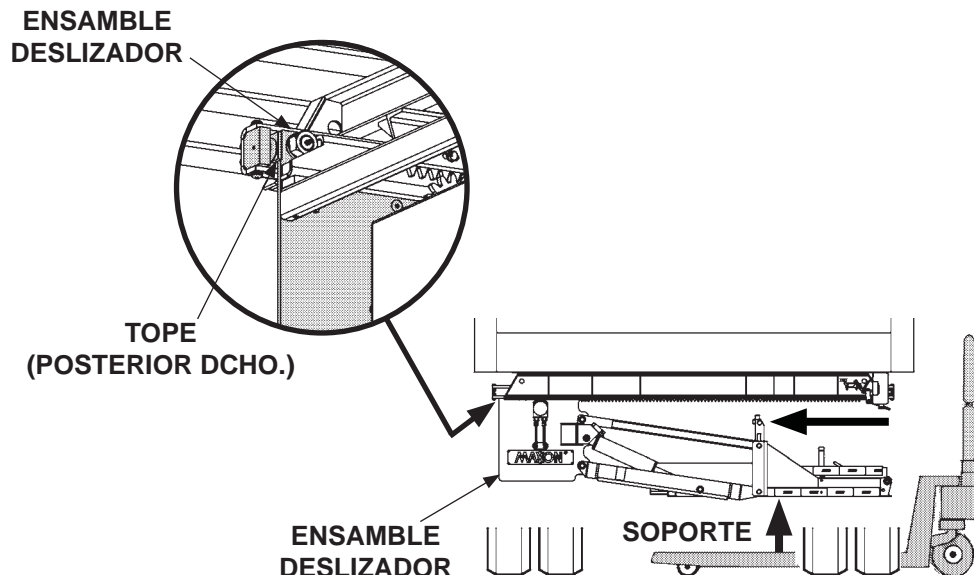

DESPLAZAR PLATAFORMA HACIA ADENTRO
FIG. 21-2

10. Reinstale los topes frontales derecho e izquierdo (**FIG. 22-1**).

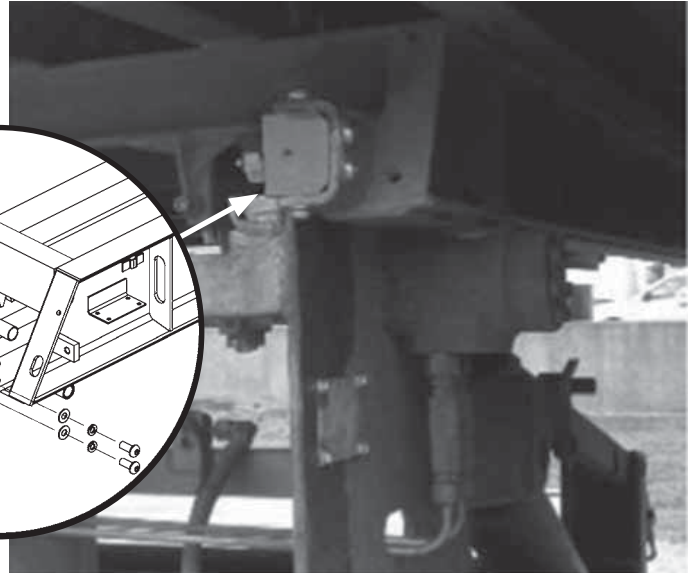
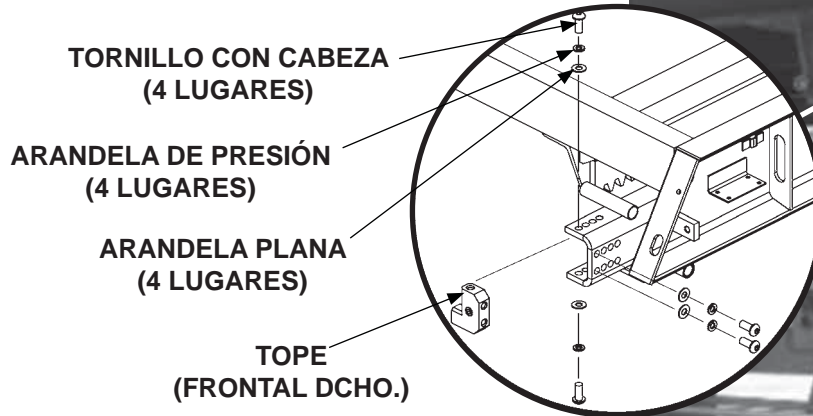

ENSAMBLE DESLIZADOR GUARDADO POR COMPLETO Y TOPES FRONTALES REINSTALADOS
FIG. 22-1

11. Bombee grasa EP para chasis en los puntos de lubricación de los ejes frontales (**FIG. 22-2**). Deténgase cuando la grasa comience a rebosar de los rodillos y limpie el exceso de grasa con un paño limpio-libre de pelusa.

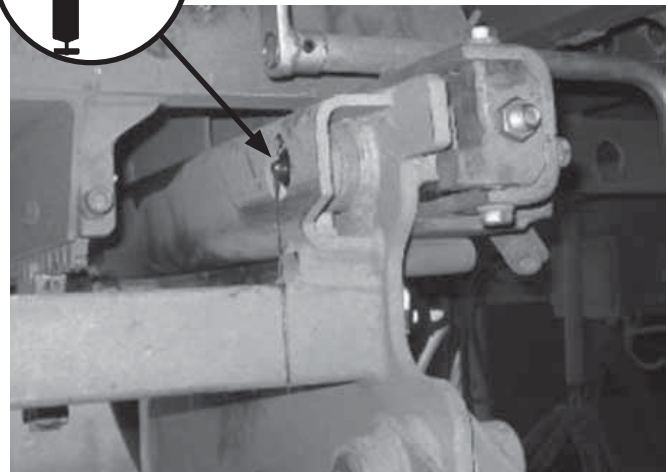

ENGRASAR NUEVO RODILLO
FIG. 22-2

12. Reinstale la palanca del interruptor de límite y asegurela insertando el pasador de rodillo (FIG. 23-1).

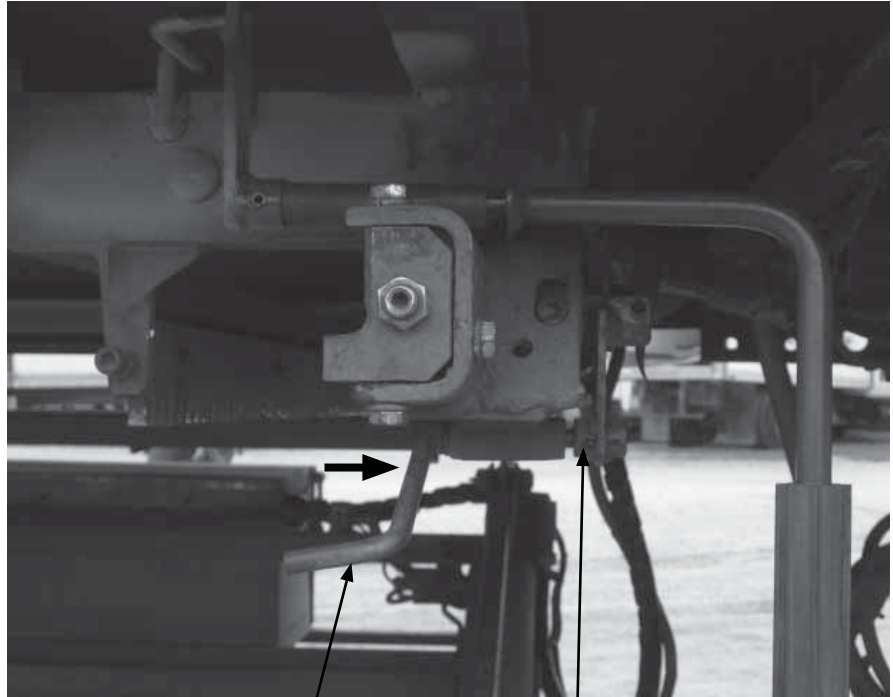

PALANCA (REINSERTAR) PASADOR DE RODILLO (REINSERTAR)

**REINSTALAR PALANCA DE INTERRUPTOR DE LÍMITE AL LADO DERECHO EN EL SOPORTE DEL VEHÍCULO
FIG. 23-1**

13. Retire los topes posteriores derecho e izquierdo (**FIG. 24-1**).

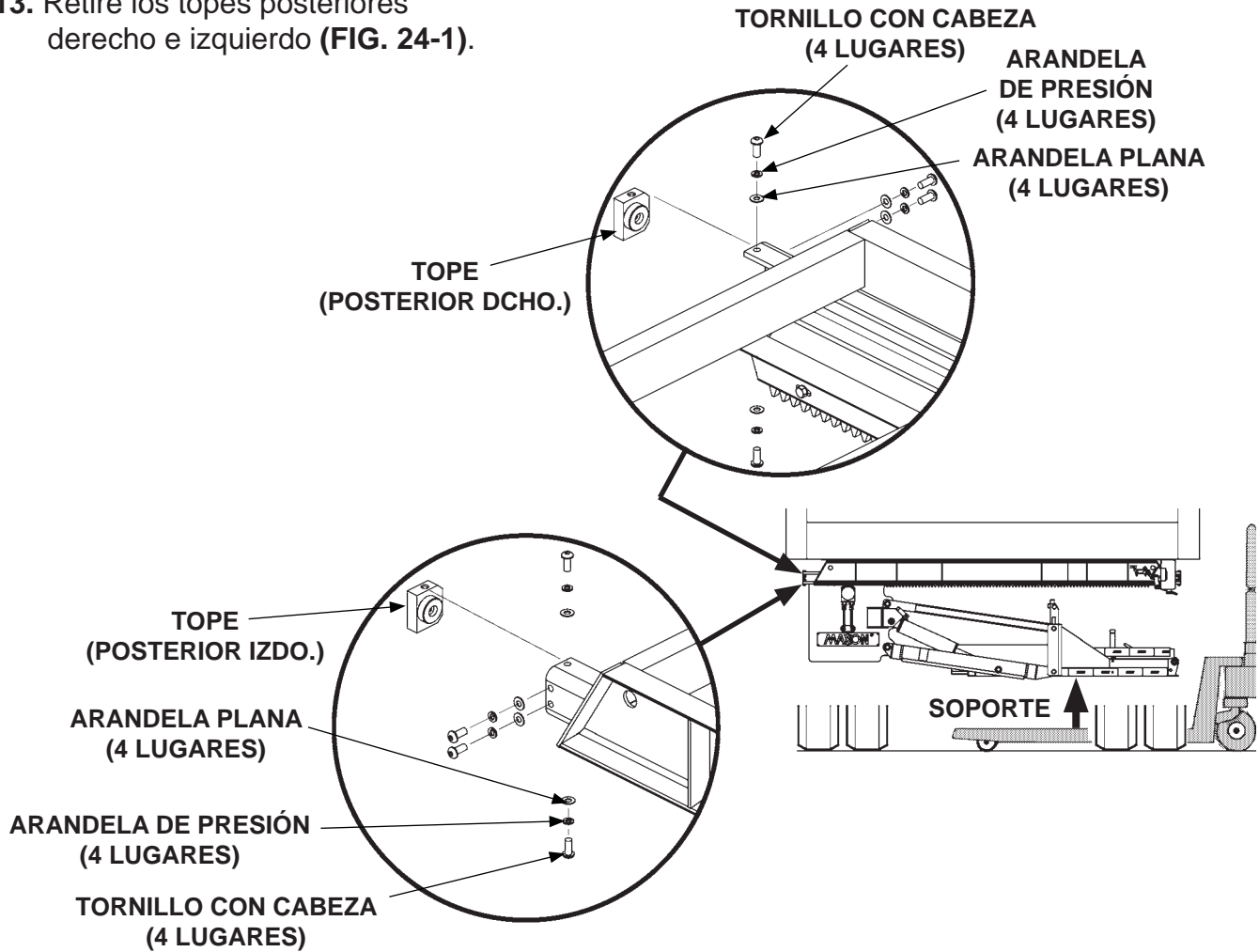

**RETIRAR TOPES POSTERIORES
(SE MUESTRA EL POSTERIOR DEL VEHÍCULO CON LA
RAMPA GUARDADA POR COMPLETO) FIG. 24-1**

NOTA: Cuando los engranajes de piñón se desensamblen de la cremallera, con una transpaleta o montacargas empuje el marco deslizador hacia afuera para sacar las últimas pulgadas.

14. Para tener acceso a los rodillos derecho e izquierdo, accione el interruptor de control hacia la posición **Adentro / IN (FIG. 25-1)** para posicionar el ensamble deslizador a aproximadamente **6" [15.2 cm]** de la posición de parada posterior.
15. Retire y deseche la tuerca hexagonal, arandela de presión, eje y rodillo del lado posterior derecho del ensamble deslizador (**FIG. 25-2**). Repita instrucción para el lado posterior izquierdo.

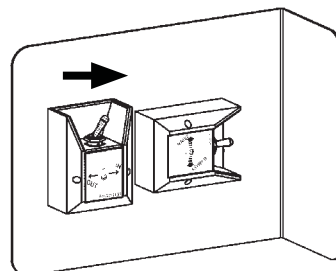

INTERRUPTOR DE CONTROL (ADENTRO)
FIG. 25-1

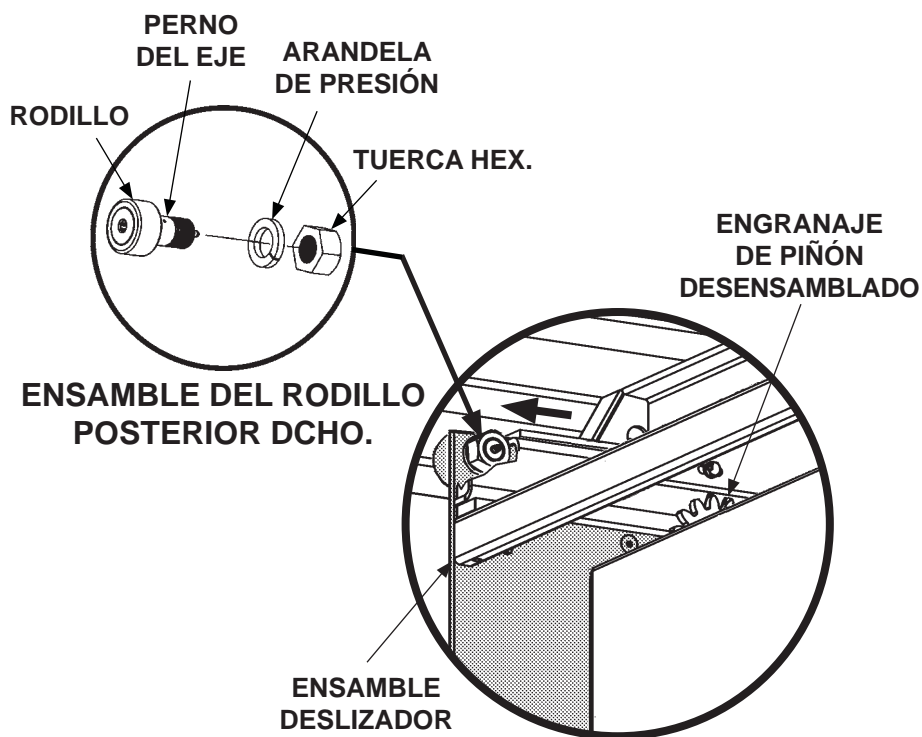

OBTENER ACCESO PARA RETIRAR RODILLO POSTERIOR DCHO.
FIG. 25-2

16. Instale el nuevo eje del seguidor de leva con su respectiva tuerca y arandela de bloqueo (**FIG. 26-1**). Aplique un torque de **140 lb-ft [189.8 N·m]**.
17. Coloque una arandela de teflón en el perno y después coloque el rodillo (**FIG. 26-1**). Al final ponga la tapa al rodillo del eje.
18. Repita los pasos 15 a 17 para instalar el rodillo frontal izquierdo.

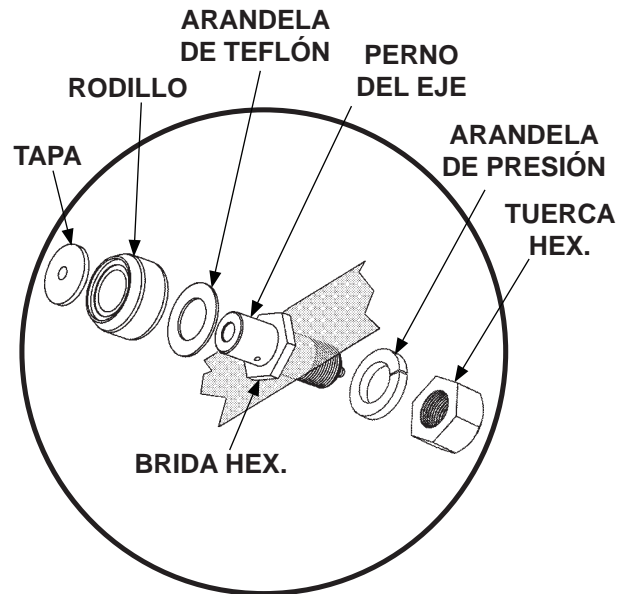

**INSTALAR KIT DE RODILLO
PARA SEGUIDOR DE LEVA
FIG. 26-1**

NOTA: Empuje el ensamble deslizador manualmente con una transpaleta o montacargas, para reensamblar los piñones con la cremallera.

19. Mueva el ensamble deslizador para reinsertar los rodillos posteriores en los canales del marco deslizador y para ensamblar el piñón y la cremallera (FIGS. 27-2A y 27-2B). Cuando el piñón y la cremallera estén ensamblados, accione el interruptor de control a la posición de **Afuera / OUT** (FIG. 27-1), hasta que el riel este libre para reinstalar los topes posteriores (FIG. 27-2B).

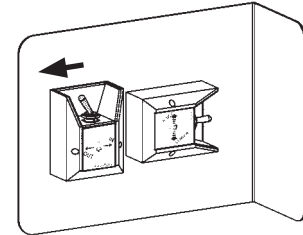

INTERRUPTOR DE CONTROL (AFUERA)
FIG. 27-1

20. Reinstale los topes posteriores derecho e izquierdo (FIGS. 27-2C y 27-2D).

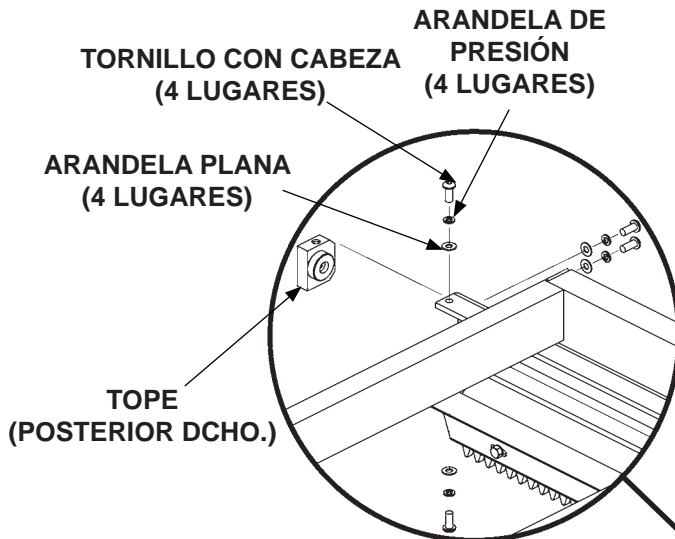

FIG. 27-2C

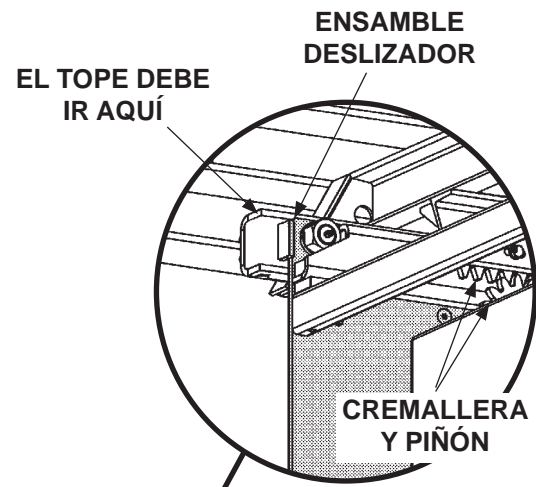

FIG. 27-2B

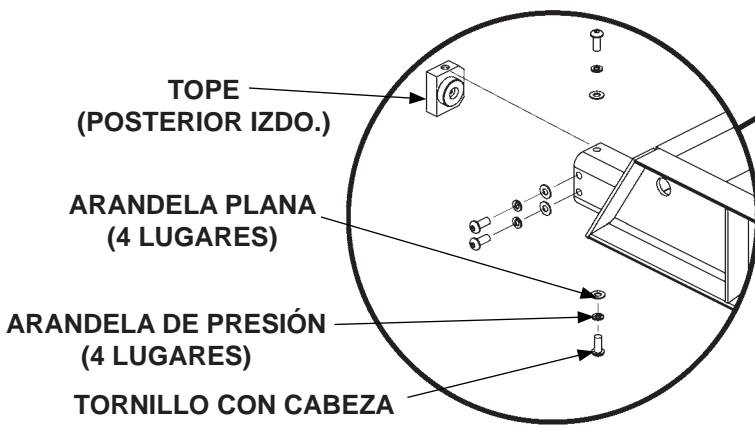
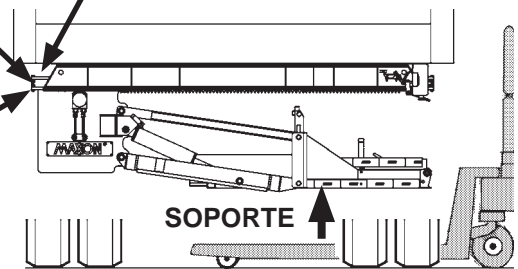
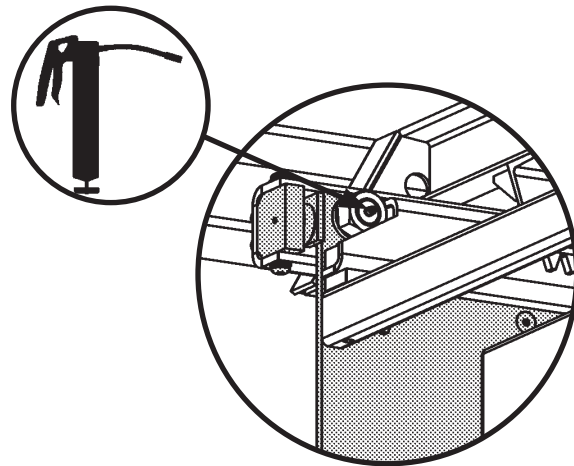

FIG. 27-2D



REINSTALAR TOPES POSTERIORES (SE MUESTRA EL POSTERIOR DEL VEHÍCULO)
FIG. 27-2A

21. Bombee grasa EP para chasis en los puntos de lubricación de los ejes (**FIG. 28-1**). Deténgase cuando la grasa comience a rebosar de los rodillos y limpie el exceso de grasa con un paño limpio-libre de pelusa. Repita instrucción para el rodillo frontal izquierdo.



ENGRASAR RODILLOS
FIG. 28-1

22. Retire la transpaleta o montacargas del elevador y el vehículo.

23. Revise la operación con los nuevos rodillos moviendo el ensamble deslizador completamente hacia afuera y hacia adentro (**FIG. 28-2**). Consulte el **Manual de Operación** para ver instrucciones de operación detalladas.

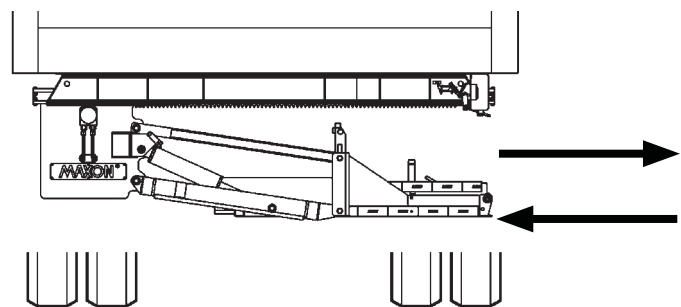

REVISAR LA OPERACIÓN
DEL ELEVADOR
FIG. 28-2