

MAXON[®]

GPT Series

M-17-06
REV. E
NOVEMBER 2021

INSTALLATION MANUAL

GPTWR-25, GPTWR-3, GPTWR-4, & GPTWR-5

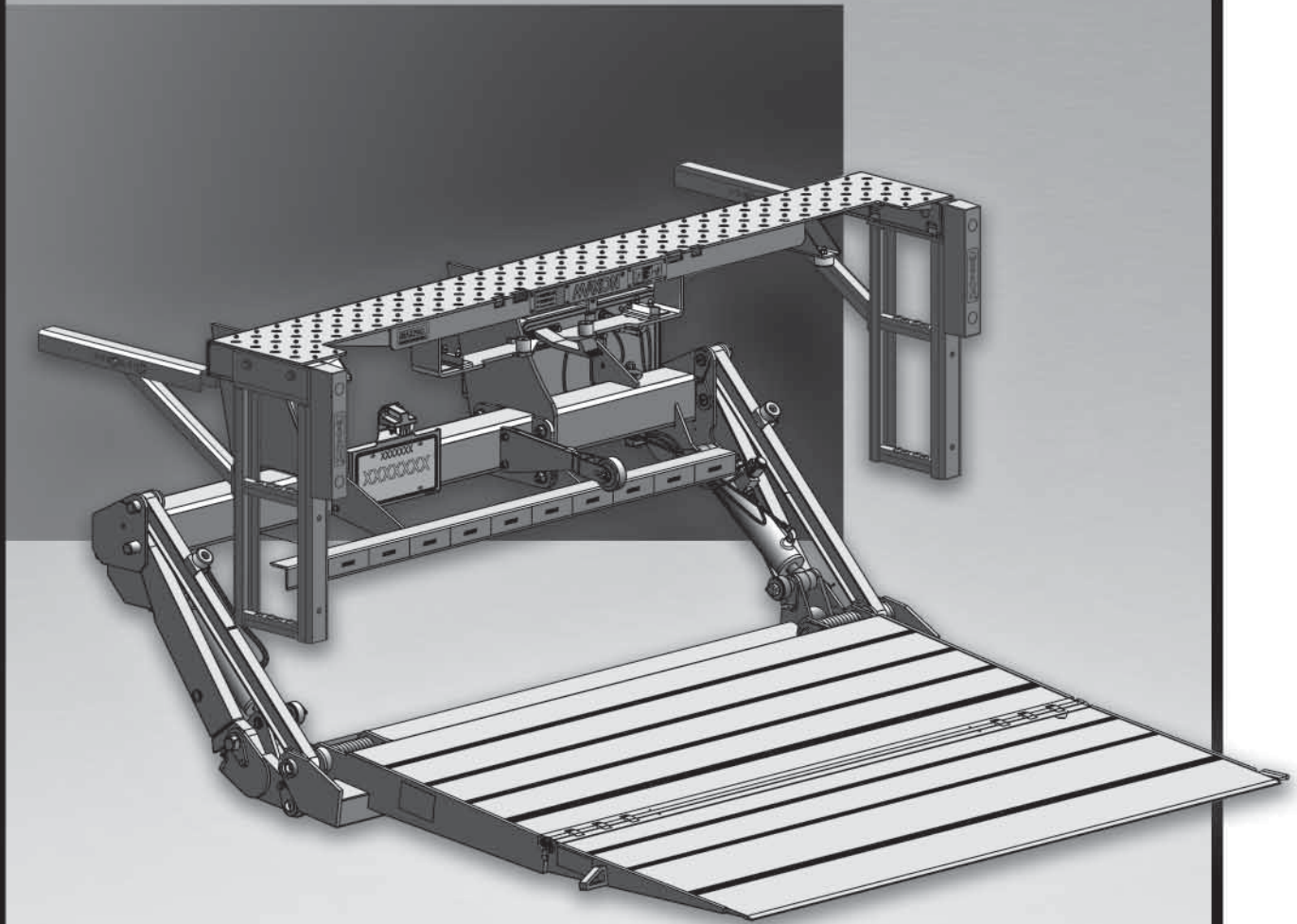

To find maintenance & parts information for your **GPTWR Liftgate**, go to www.maxonlift.com. Click the **PRODUCTS**, **TUK-A-WAY** & **GPTWR** buttons. Open the **Maintenance Manual** in the **PRODUCT DOCUMENTATION** window. For parts, click on the **PARTS PORTAL**, **TUK-A-WAY** & **GPTWR** buttons.

TABLE OF CONTENTS

SUMMARY OF CHANGES: M-17-06 REVISION E	4
WARNINGS.....	5
SAFETY INSTRUCTIONS	6
NOTICE.....	6
STANDARD LIFTGATE COMPONENTS	7
GPT INSTALLATION PARTS BOXES	8
GPTWR-SERIES MANUALS & DECALS.....	9
VEHICLE REQUIREMENTS.....	10
CENTER OF MASS.....	13
STEP 1 - ATTACH EXTENSION PLATE TO VEHICLE	14
BOLT EXTENSION PLATE	14
WELD EXTENSION PLATE (ALTERNATE METHOD)	17
STEP 2 - WELD LIFTGATE TO VEHICLE	19
STEP 3 - ATTACH OPTIONAL BATTERY BOX & FRAME TO VEHICLE (IF EQUIPPED) ..	23
STEP 4 - RUN POWER & GROUND CABLES.....	31
STEP 5 - CONNECT POWER CABLE.....	33
STEP 6 - CONNECT GROUND CABLE	36
STEP 7 - INSTALL CONTROL SWITCH	38
STEP 8 - CHECKING HYDRAULIC FLUID.....	40
STEP 9 - CONNECT POWER & GROUND CABLES TO BATTERY	42
STEP 10 - REMOVE LOCKING ANGLES & KNUCKLE BOLTS, CHECK FOR INTERFERENCE.....	43
STEP 11 - INSTALL OPENER & LICENSE PLATE BRACKET WITH ICC BUMPER OR UNDERRIDE.....	48
INSTALLATION WITH ICC BUMPER	48
INSTALLATION WITH UNDERRIDE	50
STEP 12 - ADJUST PLATFORM (IF REQUIRED)	52
STEP 13 - FINISH WELDING LIFTGATE TO VEHICLE	54
STEP 14 - BOLT STEPS TO EXTENSION PLATE	55
STEP 15 - ADJUST WALK RAMP PADS	59
STEP 16 - VEHICLE TAILLIGHT POSITIONING	60

STEP 17 - LUBE GREASE FITTINGS AS NEEDED.....	61
APPLY DECALS	62
DECALS & PLATES	64
TOUCH-UP PAINTED OR GALVANIZED FINISH	65
SYSTEM DIAGRAMS	66
PUMP MOTOR & SOLENOID SWITCH OPERATION - SINGLE PUMP	66
PUMP MOTOR & SOLENOID SWITCH OPERATION - DUAL PUMPS	67
HYDRAULIC SCHEMATIC (POWER DOWN)	68
HYDRAULIC SCHEMATIC (POWER DOWN) - DUAL PUMPS.....	69
ELECTRICAL SCHEMATIC (POWER DOWN).....	70
ELECTRICAL SCHEMATIC (POWER DOWN) - DUAL PUMPS.....	71
GPTWR ELECTRICAL VALUES & TORQUE SPECIFICATIONS.....	72
OPTIONS	73
OPTIONAL LIFTGATE COMPONENTS.....	73
PRE-DELIVERY INSPECTION FORM.....	75

SUMMARY OF CHANGES: M-17-06 REVISION E

PAGE	DESCRIPTION OF CHANGE
COVER	Updated REV and date of release.
8	Updated ground cable to 57.75" long cable in Parts Box A. Added new cap screw, flatwasher and lock nut to Parts Boxes A and C. Removed plastic ties (items for packaging) from Parts Boxes A and C. Added 1/4" flat in Parts Box B to use for shim.
16	Updated weld specifications in FIG. 16-1 for LH and RH ends of the extension plate.
25	Added weld-on option for frame hanger brackets.
26	Combined instructions from paragraph 4 with paragraph 3 on page 25. Renumbered paragraphs after page 26.
27	Updated battery positive (+) to positive (+) red cable and negative (-) to negative (-) black cable from 8" to 10" LG.
30	Updated battery box assembly illustration to identify ground cable from vehicle battery.
31, 32	Added instructions to install 38 ft dedicated ground cable, and a NOTE about the electrical cables in Parts Boxes A & C.
36-37	Updated instructions to connect ground cable to pump manifold instead of pump mounting bracket, and connect ground cable to vehicle chassis with fasteners from Parts Box A. Added note to connect dedicated ground cable to vehicle battery.
41	Updated tables of recommended hydraulic oils.
42, 48, 49, 50, 51, 55, 58	Added instructions to connect/disconnect dedicated ground cable (if installed) to battery negative terminal.
52	Added note about making a 3/16" shim.

Comply with the following **WARNINGS** and **SAFETY INSTRUCTIONS** while installing Liftgates. See Operation Manual for operating safety requirements.

WARNING

Installing and maintaining a liftgate can expose you to chemicals, including lead, which are known to the State of California to cause cancer and birth defects or other reproductive harm. To minimize exposure, install and maintain liftgate in a well-ventilated area and wear **proper Personal protective equipment (PPE)**. For more information go to www.P65Warnings.ca.gov.

WARNING

- Do not stand, or allow obstructions, under the platform when lowering the Liftgate. **Be sure your feet are clear of the Liftgate.**
- **Keep fingers, hands, arms, legs, and feet clear of moving Liftgate parts (and platform edges) when operating the Liftgate.**
- **Correctly stow platform when not in use. Extended platforms could create a hazard for people and vehicles passing by.**
- **Make sure vehicle battery power is disconnected** while installing Liftgate. Connect vehicle battery power to the Liftgate only when installation is complete or as required in the installation instructions.
- If it is necessary to stand on the platform while operating the Liftgate, keep your feet and any objects clear of the inboard edge of the platform. Your feet or objects on the platform can become trapped between the platform and the Liftgate extension plate.
- Never perform unauthorized modifications on the Liftgate. Modifications may result in early failure of the Liftgate and may create hazards for Liftgate operators and maintainers.
- Recommended practices for welding on steel parts are contained in the current **AWS (American Welding Society) D1.1 Structural Welding Code - Steel**. Damage to Liftgate and/or vehicle, and personal injury can result from welds that are done incorrectly.
- Recommended practices for welding galvanized steel are contained in the current **AWS (American Welding Society) D19.0 Welding Zinc-Coated Steel**. Damage to Liftgate and/or vehicle, and personal injury can result from welds that are done incorrectly.

SAFETY INSTRUCTIONS

- Read and understand the instructions in this **Installation Manual** before installing Liftgate.
- Before operating the Liftgate, read and understand the operating instructions in **Operation Manual**.
- Comply with all **WARNING** and instruction decals attached to the Liftgate.
- Keep decals clean and legible. If decals are illegible or missing, replace them. Free replacement decals are available from **Maxon Customer Service**.
- Consider the safety and location of bystanders and location of nearby objects when operating the Liftgate. Stand to one side of the platform while operating the Liftgate.
- Do not allow untrained persons to operate the Liftgate.
- Wear appropriate safety equipment such as protective eyeglasses, faceshield and clothing while performing maintenance on the Liftgate and handling the battery. Debris from drilling and contact with battery acid may injure unprotected eyes and skin.
- Be careful working by an automotive type battery. Make sure the work area is well ventilated and there are no flames or sparks near the battery. Never lay objects on the battery that can short the terminals together. If battery acid gets in your eyes, immediately seek first aid. If acid gets on your skin, immediately wash it off with soap and water.
- If an emergency situation arises (vehicle or Liftgate) while operating the Liftgate, release the control switch to stop the Liftgate.
- A correctly installed Liftgate operates smoothly and reasonably quiet. The only noticeable noise during operation comes from the power unit while the platform is raised and lowered. Listen for scraping, grating and binding noises and correct the problem before continuing to operate Liftgate.

NOTICE

- Maxon Lift is responsible for the instructions to correctly install **MAXON** Liftgates on trucks or trailers only.
- Liftgate installers, not Maxon Lift, are responsible for reviewing and complying with all applicable Federal, State, and Local regulations pertaining to the trailer or truck.
- Installers of the liftgate should ensure that all trucks and trailers are equipped with grab handles as needed. Refer to Technology Maintenance Council (TMC) RP 1428: Entry And Egress Guidelines for Vehicles With Fold-Under Type Liftgates.

STANDARD LIFTGATE COMPONENTS

⚠ CAUTION

Unpacking the Liftgate on unlevel surface may allow heavy components to slide off when shipping bands are cut. Injury and equipment damage could result. Before the shipping bands are cut, put Liftgate on level surface that will support 1500 lbs. When unpacking the Liftgate, remove heavy components carefully to avoid injury and damage.

NOTE: Make sure you have all components and parts before you start installing Liftgate. Compare parts in the part box and each kit box with packing list enclosed in each box. If parts and components are missing or incorrect, call:

Maxon Customer Service
Call (800) 227-4116 or
Send e-mail to cservice@maxonlift.com

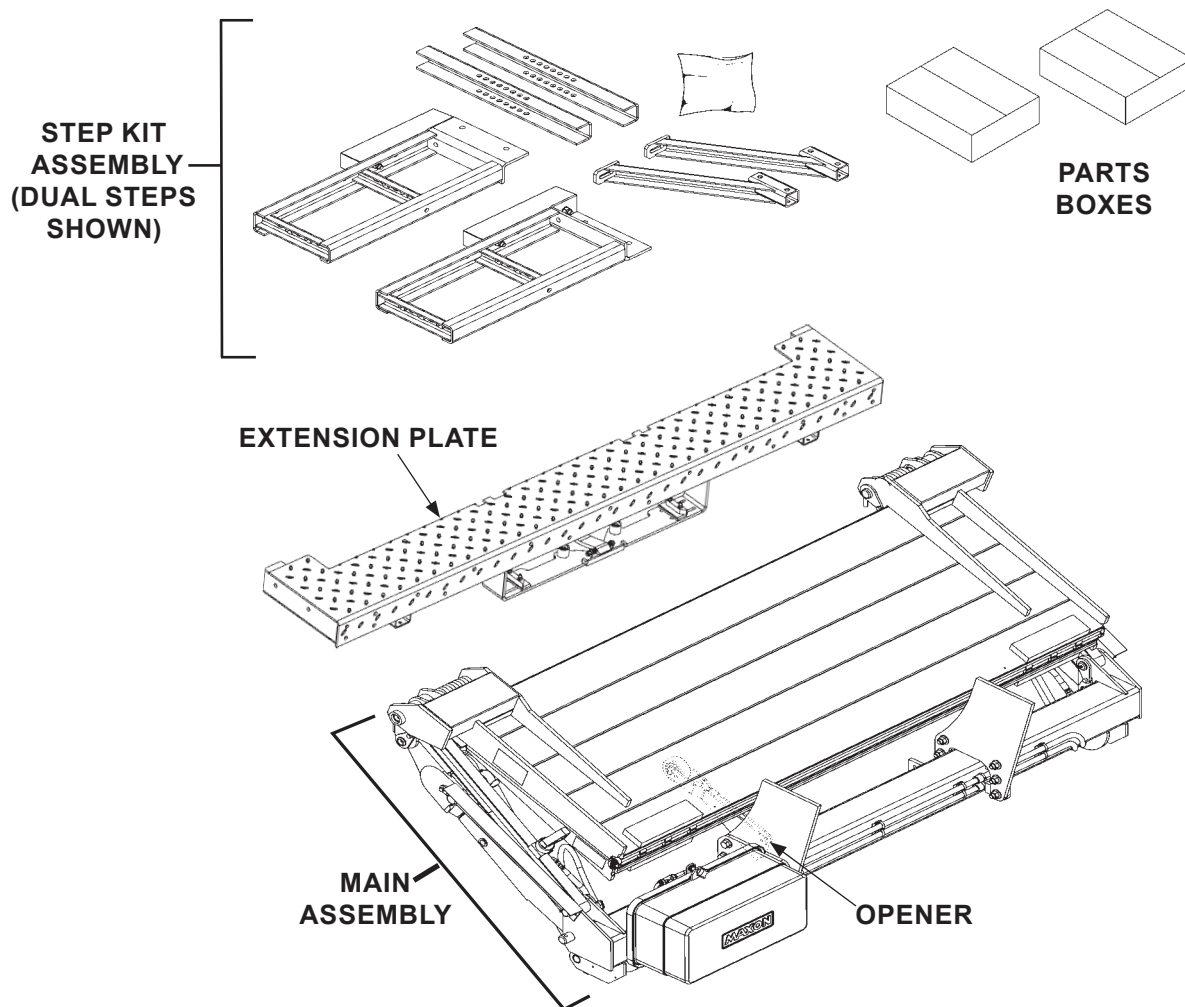

TYPICAL LIFTGATE COMPONENTS FOR SHIPMENT
(OPTIONAL COMPONENTS NOT SHOWN)

FIG. 7-1

GPTWR INSTALLATION PARTS BOXES

ITEM	NOMENCLATURE OR DESCRIPTION	QTY.	PART NUMBER
REF	PARTS BOX A	1	297502-01
1	SPRING CLIP, 1/2" x 1-3/8"	10	050079
2	#10 RUBBER LOOM CLAMP	2	801681
3	CABLE ASSEMBLY, 175 AMPS, 38 FT LG.	1	264422
4	SELF-TAPPING SCREW, 10 X 1/2" LG.	2	030458
5	CABLE ASSEMBLY, 2 GA, BLACK, 57-3/4" LG.	1	268226-13
6	CAP SCREW, 3/8"-16 X 1-1/2", GR8	1	900014-6
7	FLAT WASHER, 3/8"	2	902001-2
8	LOCKNUT, 3/8"-16	1	901002
9	PLASTIC TIE WRAP	2	206864

**PARTS BOX A
TABLE 8-1**

ITEM	NOMENCLATURE OR DESCRIPTION	QTY.	PART NUMBER
REF	PARTS BOX B	1	297049-02
1	SHIM, 2-1/2" X 1" X 16 GAUGE	2	264732
2	TOGGLE SWITCH ASSEMBLY	1	296855-01
3	HEX NUT, 1/2"-13	2	901011-9
4	CAP SCREW, 1/2"-13 X 1-1/2" LG.	2	900035-3
5	INSTALLATION BRACKET	2	269462-01
6	LUG, 2 GAUGE, COPPER, 5/16"	1	906497-02
7	SCREW, SELF TAPPING, #10-24 X 1-1/2" LG.	2	900057-7
8	HEAT SHRINK TUBING, 3/4" X 1-1/12" LG.	1	253316-04
9	FLAT, 2-1/2" X 1" X 1/8" THICK	2	201999
10	FLAT, 2-1/2" X 1" X 1/4" THICK	2	090144-38
11	LICENSE PLATE BRACKET KIT	1	287015-01

**PARTS BOX B
TABLE 8-2**

ITEM	NOMENCLATURE OR DESCRIPTION	QTY.	PART NUMBER
REF	PARTS BOX C	1	297502-02
1	SPRING CLIP	20	050079
2	CABLE ASSY, 175 AMP 38 FT LG.	1	264422
3	GROUND CABLE ASSY, 2 GA X 38 FT LG.	1	269191-01
4	#10 LOOM CLAMP	2	801681
5	SELF-TAPPING SCREW, 10 X 1/2" LG.	2	030458
6	CAP SCREW, 3/8"-16 X 1-1/2", GR8	1	900014-6
7	FLAT WASHER, 3/8"	2	902001-2
8	LOCKNUT, 3/8"-16	1	901002
9	PLASTIC TIE WRAP	2	206864

**PARTS BOX C
TABLE 8-3**

MAXON[®] 11921 Slauson Ave. Santa Fe Springs, CA. 90670 (800) 227-4116 FAX (888) 771-7713

GPTWR-SERIES MANUALS & DECALS

NOTE: To find maintenance information for your **GPTWR Liftgate**, go to **www.max-onlift.com**. Click the **PRODUCTS**, **TUK-A-WAY** & **GPTWR** buttons. Open the **Maintenance Manual** in the **PRODUCT DOCUMENTATION** window. For parts, click on the **PARTS PORTAL**, **TUK-A-WAY** & **GPTWR** buttons.

ITEM	NOMENCLATURE OR DESCRIPTION	QTY.	PART NUMBER
REF	DECAL & MANUAL KIT	1	298125-11 (GPTWR-25)
			298125-12 (GPTWR-3)
			298125-13 (GPTWR-4)
			298125-14 (GPTWR-5)
1	INSTALLATION MANUAL (GPTWR)	1	M-17-06
2	OPERATION MANUAL (GPT & GPTWR)	1	M-17-07
3	DECALS (SEE DECAL PAGES IN THIS MANUAL)	1	(ALL GPTWR'S)

TABLE 9-1

MAXON[®] 11921 Slauson Ave. Santa Fe Springs, CA. 90670 (800) 227-4116 FAX (888) 771-7713

VEHICLE REQUIREMENTS

NOTE: BODY maximum and minimum operating bed height, for GPTWR models with standard platform, are as follows.

Maximum height is **55"** (Unloaded). Loaded height is **49"**. On vehicle bodies equipped with swing-open doors, extension plate and vehicle body must be modified to install this Liftgate.

NOTE: Make sure vehicle is parked on level ground while preparing vehicle and installing Liftgate.

NOTE: Dimensions are provided as reference for fitting Liftgate to vehicle body.

1. Check for correct clearances (**FIG. 10-1 & 10-2**) on vehicle to prevent interference between vehicle and Liftgate.

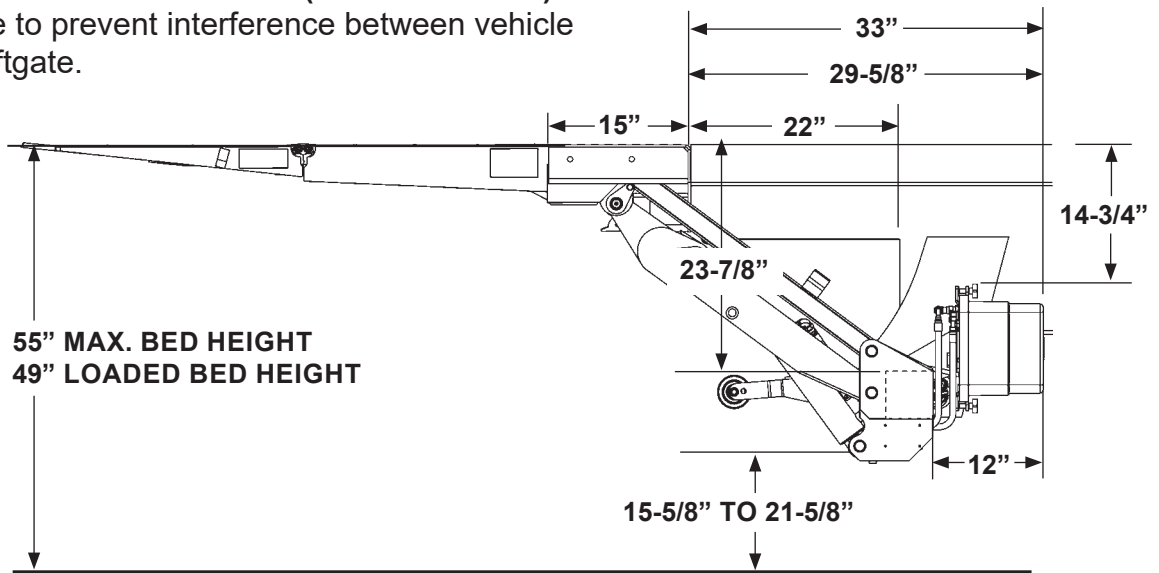

**GPTWR-25 & GPTWR-3 LIFTGATE CLEARANCE DIMENSIONS
FIG. 10-1**

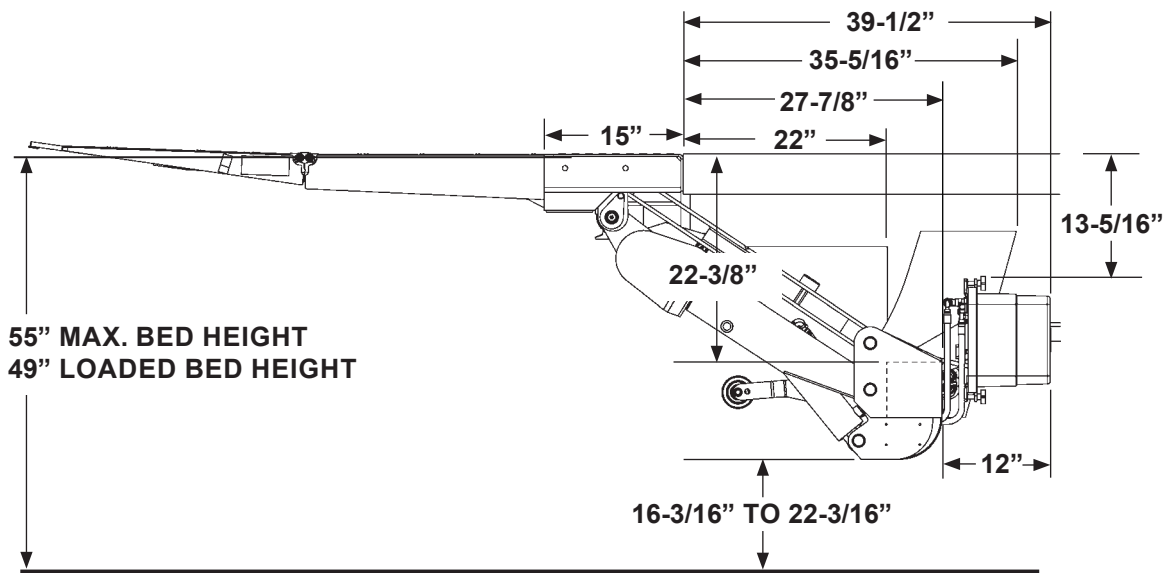

**GPTWR-4 & GPTWR-5 LIFTGATE CLEARANCE DIMENSIONS
FIG. 10-2**

VEHICLE REQUIREMENTS - Continued

- Check for correct clearances between walk ramp, walk ramp box, and the extension plate (FIGS. 11-1 and 11-1A) to prevent interference.

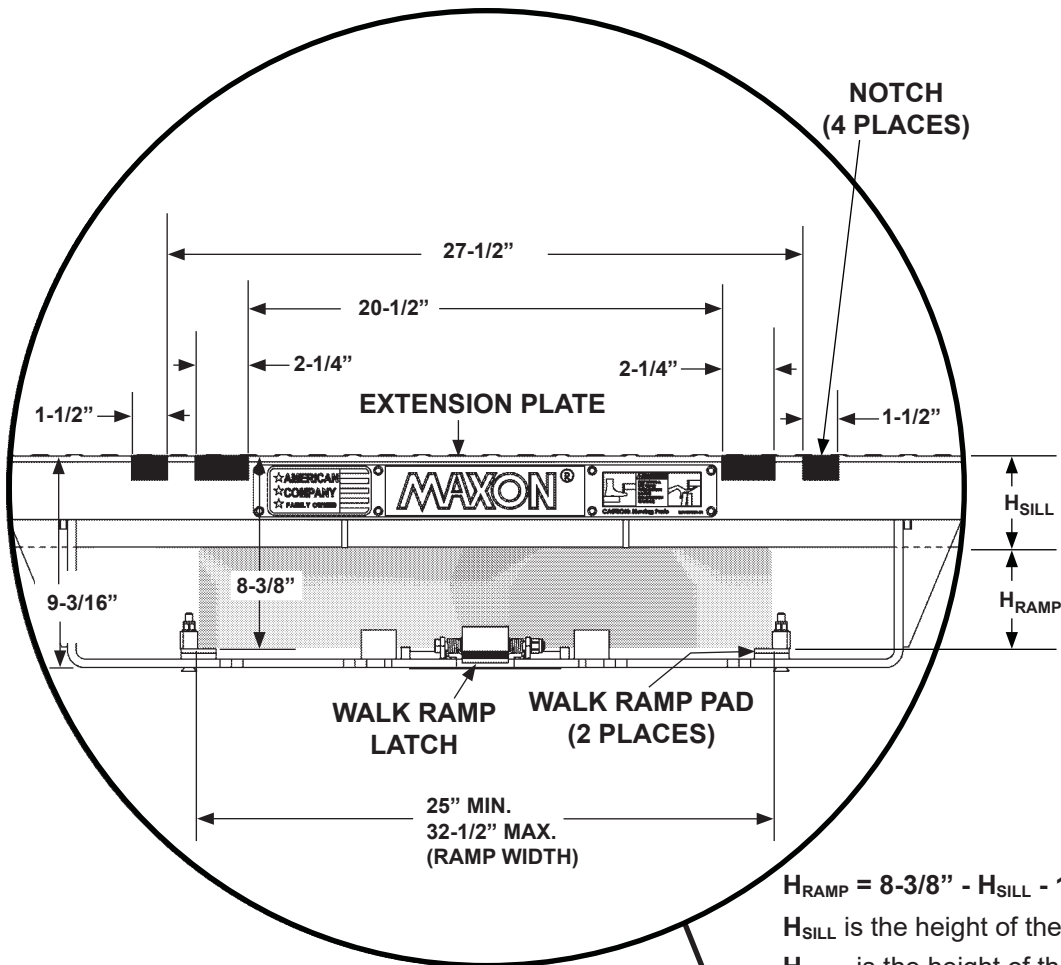

**WALK RAMP BOX
CLEARANCE DIMENSIONS
(FOR REFERENCE ONLY)
FIG. 11-1A**

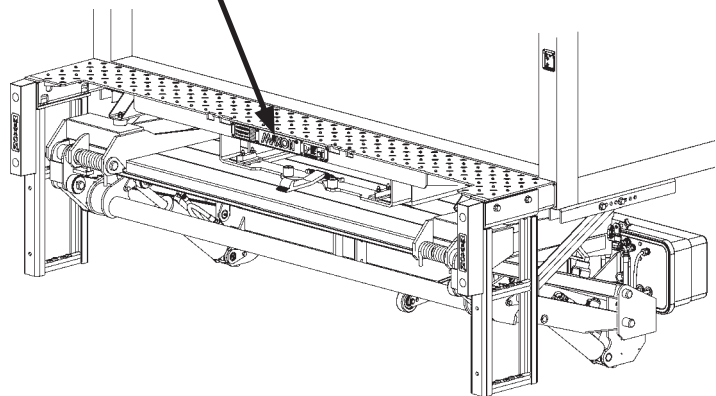

**GPTWR LIFTGATE WITH WALK RAMP BOX
FIG. 11-1**

VEHICLE REQUIREMENTS - Continued

⚠ WARNING

Incorrect modification of vehicle frame and/or body could contribute to serious mechanical failure of the vehicle. Serious injury to operator, motorists, and bystanders could result. Installer is responsible for ensuring vehicle body and frame modification do not adversely affect the integrity of the body and frame. If unsure about modifying vehicle, installer should consult truck/trailer body manufacturer.

CAUTION

To prevent aluminum platform from being damaged, make sure vehicle frame is cut correctly and rear sills are modified if over 4-1/8" in height. If the cutouts are incorrect, platform may hit vehicle frame or underbody when stowing Liftgate. If rear sill is over 4-1/8" in height, bottom of the platform may hit the sill.

NOTE: Dimensions, shown in illustration below, are maximums except as indicated.

NOTE: The platform cutout area for truck frame, shown below, is required to prevent frame interference when platform is being stowed and unstowed. For trailers, refer to instructions supplied with trailer mounting kit for Liftgate.

3. Fit the Liftgate to vehicle body by cutting vehicle frame as shown in **FIG. 12-1**.

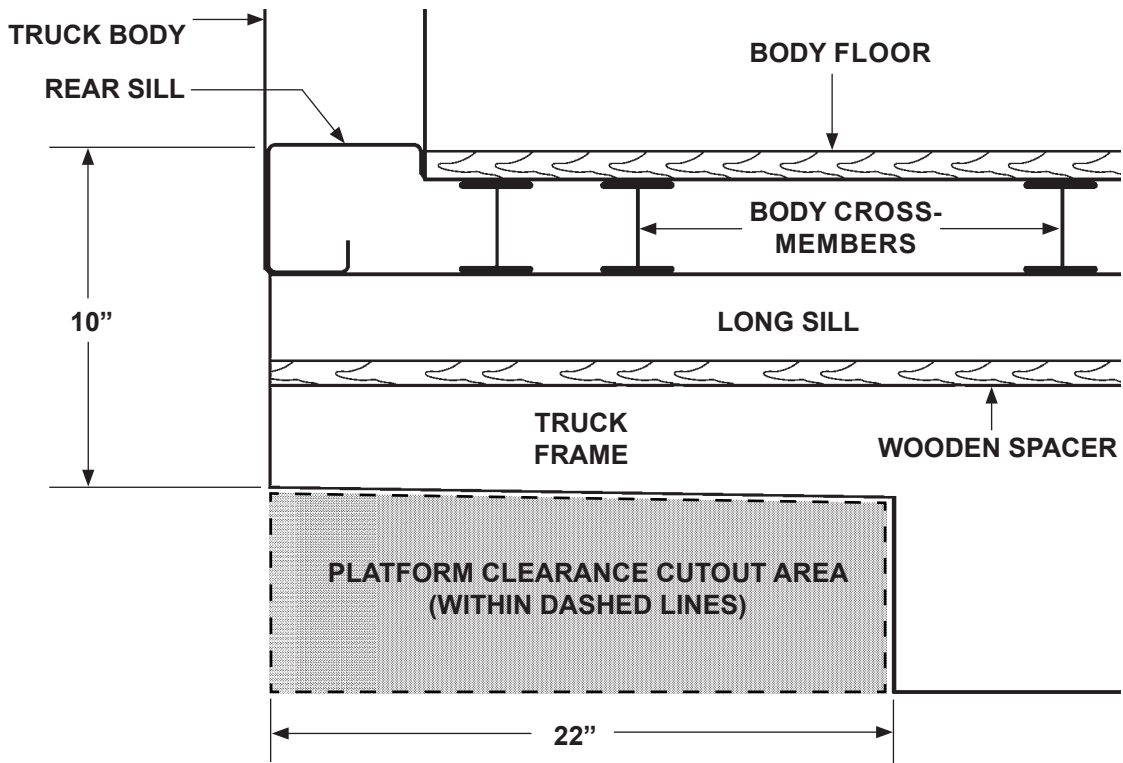

VEHICLE FRAME CUTOUT FOR GPTWR PLATFORM CLEARANCE
(TRUCK FRAME IS SHOWN)

FIG. 12-1

CENTER OF MASS

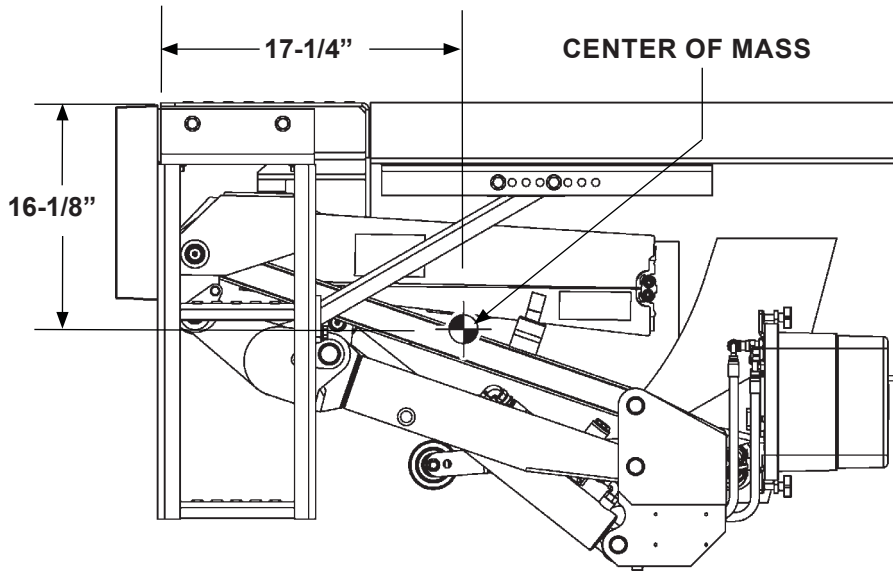

**GPTWR-25 & GPTWR-3 CENTER OF MASS
(STOWED POSITION)
FIG. 13-1**

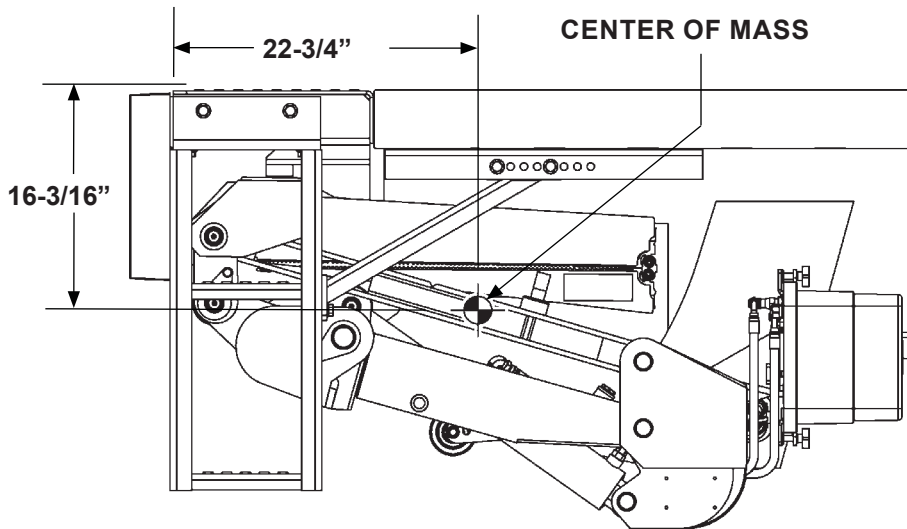

**GPTWR-4 & GPTWR-5 CENTER OF MASS
(STOWED POSITION)
FIG. 13-2**

STEP 1 - ATTACH EXTENSION PLATE TO VEHICLE

CAUTION

To preserve the corrosion-resistant properties of the galvanized finish, MAXON recommends bolting the galvanized extension plate to vehicle.

NOTE: GPTWR Liftgate extension plate comes with bolt holes so it can be bolted to vehicle body with optional bolt kit. GRADE 8 bolts are required. MAXON recommends getting the optional extension plate hardware kit listed in OPTIONS section. Vehicle body must be drilled according to instructions. Extension plate may also be welded to vehicle body. Do the following bolting or welding instructions for the extension plate.

BOLT EXTENSION PLATE

1. Mark and drill holes into rear sill as shown in FIGS. 14-1 and 15-1.

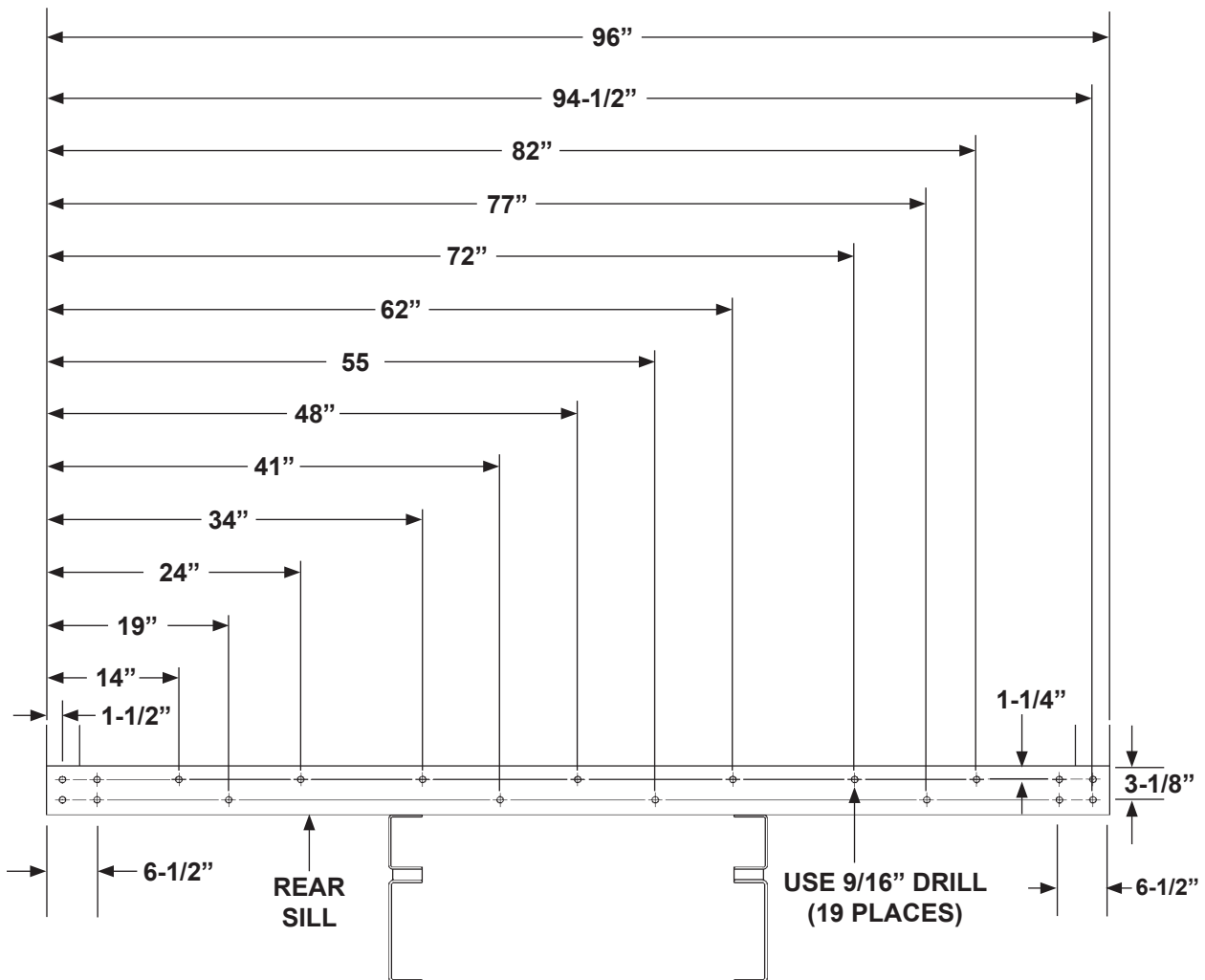

REAR SILL - HOLE LOCATIONS FOR 96" WIDE VEHICLE
FIG. 14-1

STEP 1 - ATTACH EXTENSION PLATE TO VEHICLE - Continued

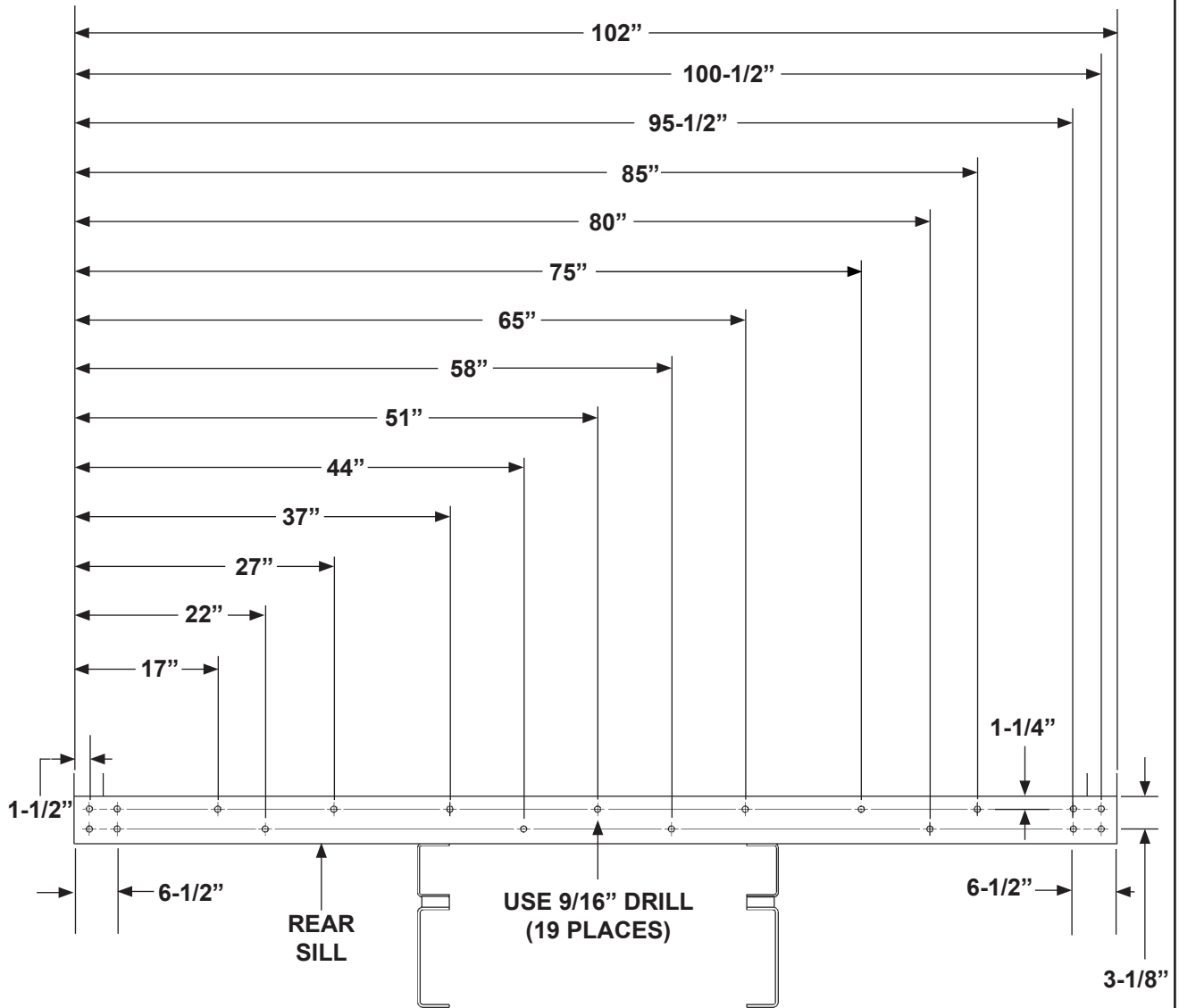

**REAR SILL - HOLE LOCATIONS FOR 102" WIDE VEHICLE
FIG. 15-1**

MAXON[®] 11921 Slauson Ave. Santa Fe Springs, CA. 90670 (800) 227-4116 FAX (888) 771-7713

STEP 1 - ATTACH EXTENSION PLATE TO VEHICLE - Continued

CAUTION

The mating surface between the bolt-on extension plate and vehicle rear sill must be as flat as possible. Interference between the mating surfaces could result in a distorted top surface of extension plate when all the bolts are tightened. Distorted extension plate can also make the dual steps difficult to install correctly. Remove interference or shim rear sill to eliminate or reduce the possibility of a distorted extension plate.

NOTE: Do not tighten extension plate bolts and lock nuts until:

- All the bolts and lock nuts are in place.
- Mating surfaces of extension plate and rear sill are made flat as possible.
- Top of extension plate is flush with top of rear sill.

NOTE: Weld the LH and RH ends of the extension plate to vehicle body as shown in **FIG. 16-1** if any of the following conditions apply.

- Bolt holes are not accessible on the corner posts of the vehicle body.
- Liftgate will be used for dock loading applications.
- As required by body/trailer manufacturer

2. Bolt extension plate to vehicle as shown in **FIG. 16-1**. If necessary, reposition extension plate so top surface is flush with top surface of sill. Then, torque bolts and lock nuts to **105 +/-20 lb-ft.**

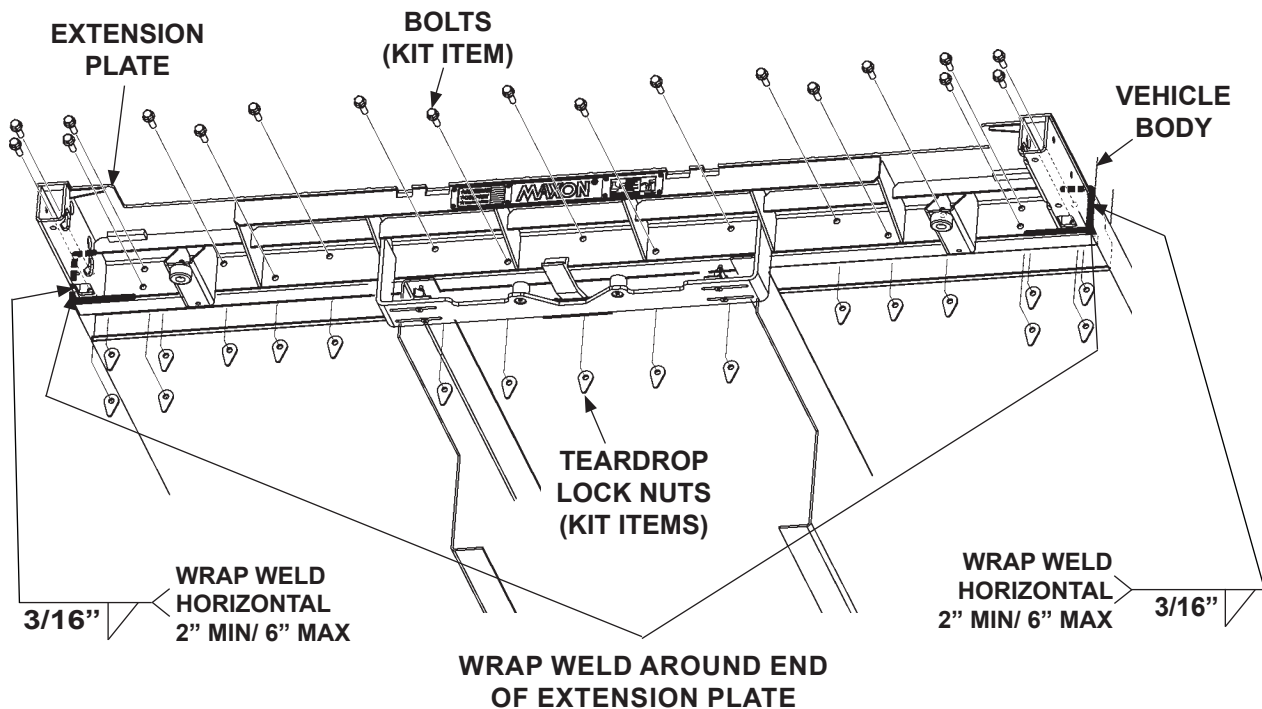

BOLTING EXTENSION PLATE (96" WIDE EXTENSION PLATE SHOWN)

FIG. 16-1

NOTE: An optional 102" wide extension kit is available for 102" wide vehicles.

STEP 1 - ATTACH EXTENSION PLATE TO VEHICLE - Continued WELD EXTENSION PLATE (ALTERNATE METHOD)

CAUTION

To preserve the corrosion-resistant properties of the galvanized finish, MAXON recommends bolting the galvanized extension plate to vehicle.

CAUTION

To protect the original paint system if equipped, a 3" wide area of paint must be removed from all sides of the weld area before welding.

NOTE: Before welding extension plate to vehicle body, make sure:

- Inboard edge of extension plate is flush with the top of sill on vehicle body.
- Top surface of extension plate is level with the ground.

1. Center the extension plate on vehicle body. Weld the extension plate to vehicle body sill as shown in FIGS. 17-1 and 18-1.

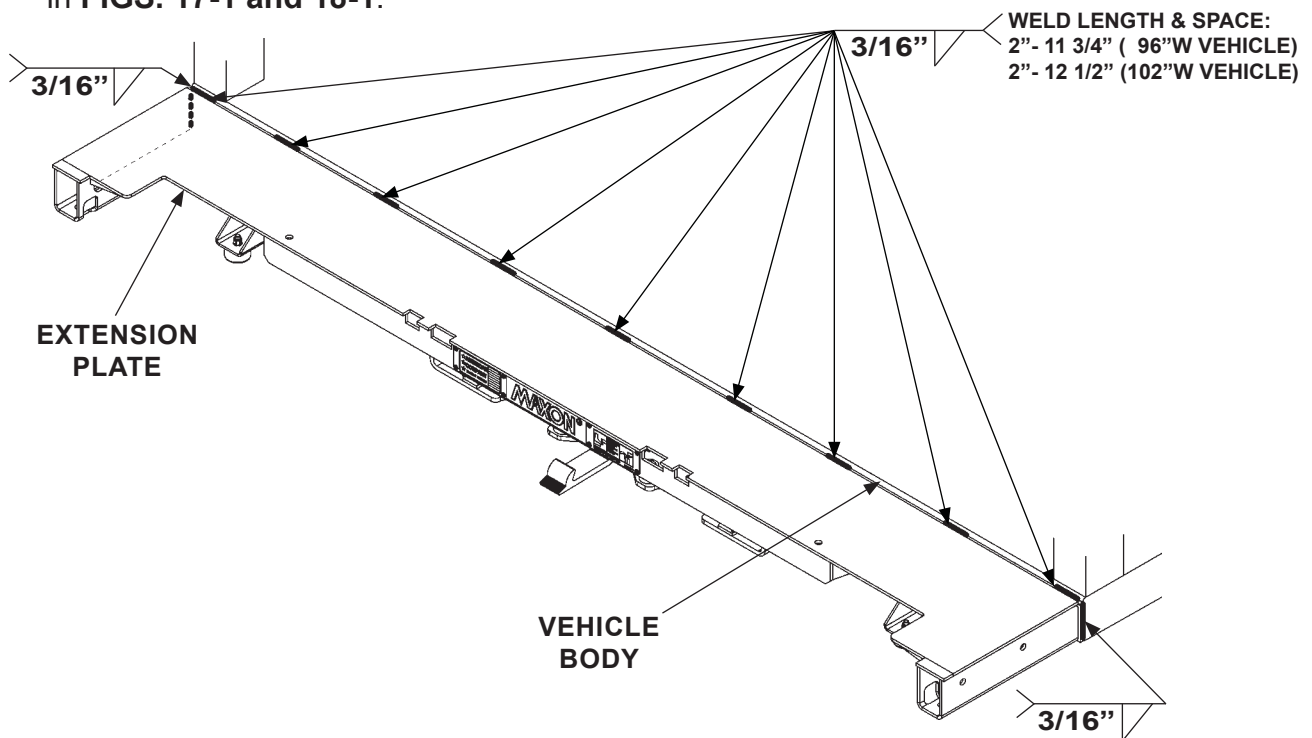

EXTENSION PLATE WELDS - VIEWED FROM ABOVE
FIG. 17-1

STEP 1 - ATTACH EXTENSION PLATE TO VEHICLE - Continued

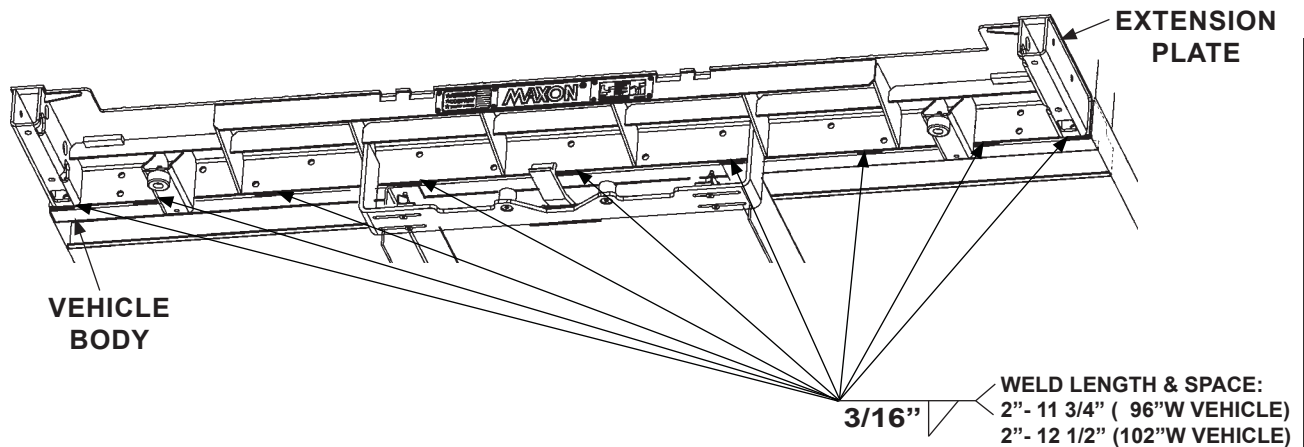

EXTENSION PLATE WELDS - VIEWED FROM UNDERNEATH
FIG. 18-1

NOTE: During installation of liftgate, installation brackets keep the heel of the platform level with extension plate and maintain a $\frac{3}{4}$ " gap between extension plate and heel of platform. The extension plate has bolt holes for bolting on the installation brackets. Make sure dowel is snug against edge of extension plate.

2. Bolt 2 installation brackets (parts bag items) on the extension plate as shown in **FIG. 18-2**. Tighten hex nuts securely.

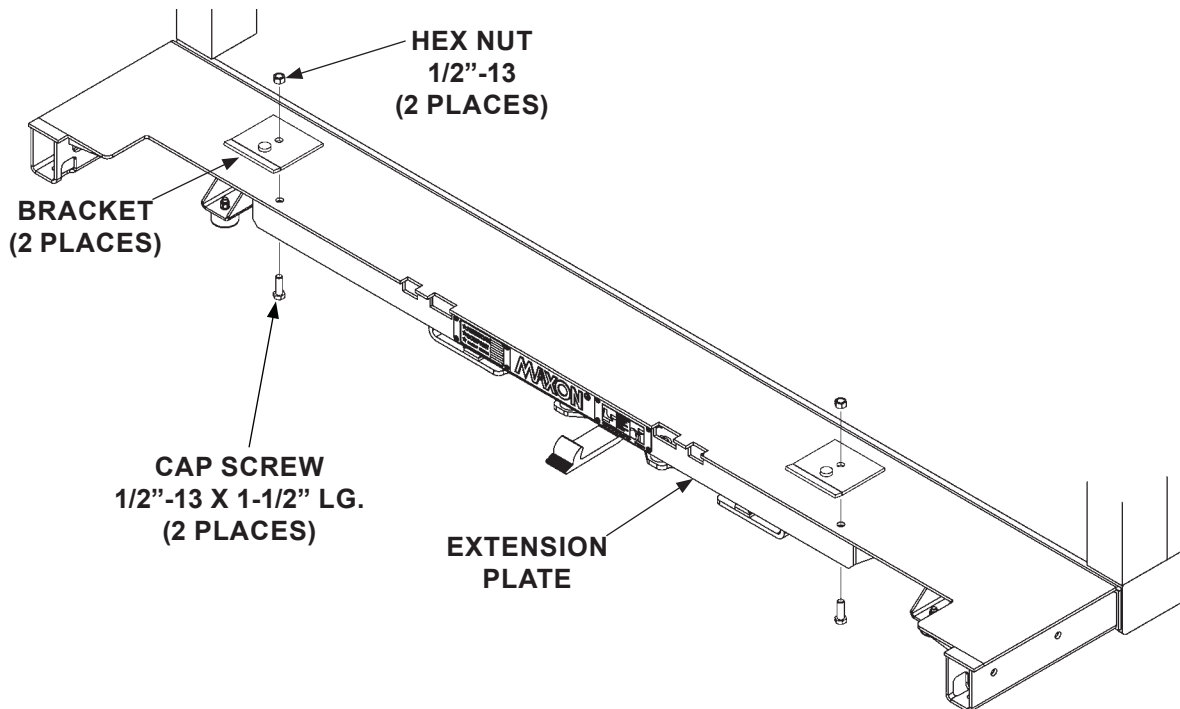

BOLTING ON INSTALLATION BRACKETS
FIG. 18-2

STEP 2 - WELD LIFTGATE TO VEHICLE

NOTE: GPTWR Liftgates are equipped with mounting plates installed at the factory. Mounting plate widths are shown based upon truck or trailer frame widths. Ensure you have the correct mounting plate kit for your application.

If it's necessary to unbolt mounting plates from main frame (**FIG 19-1**), torque mounting plate nuts and bolts **220-240 lb-ft** (GPTWR-25/GPTWR-3) or **350-375 lb-ft** (GPTWR-4/GPTWR-5).

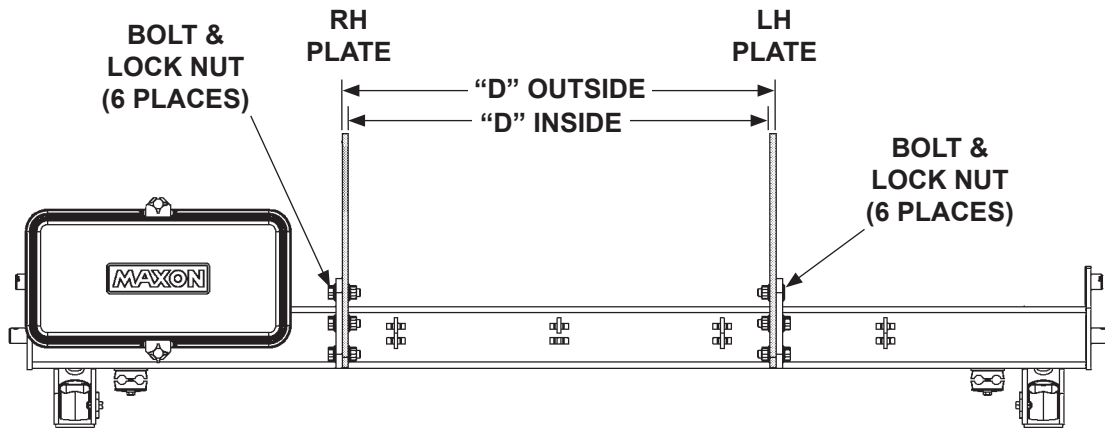

**BOLT ON MOUNTING PLATES FOR INSTALLATION ON TRUCKS & TRAILERS
(REAR VIEW OF LIFTGATE)
FIG. 19-1**

LIFTGATE MODEL	"D" INSIDE	"D" OUTSIDE	APPLICATION
ALL GPTWR'S	32-3/4"	33-3/4"	Truck
	34-1/4"	35-1/4"	Common Truck Chassis Width
	32-1/4"	33-1/4"	Trailer applications
	34-3/4"	35-3/4"	Trailer applications (91 cm)

TABLE 19-1

STEP 2 - WELD LIFTGATE TO VEHICLE - Continued

1. Unfold the platform and flipover (FIG. 20-1).

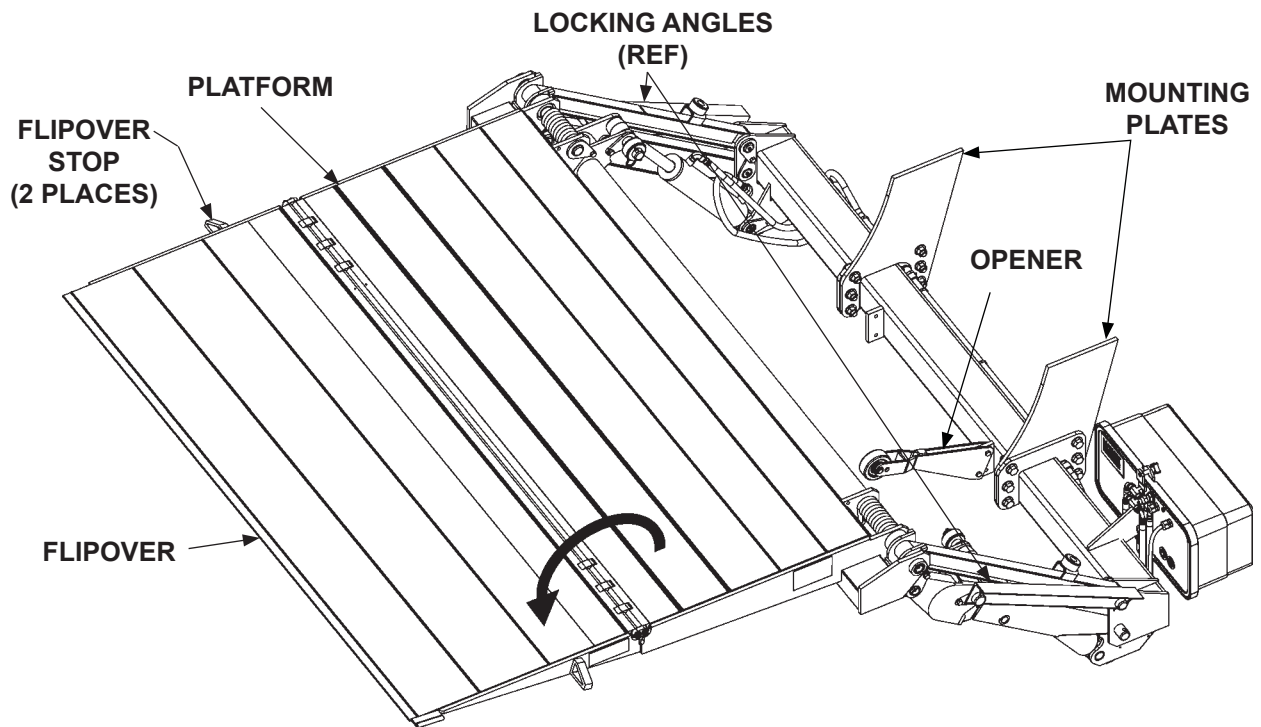

PLATFORM & FLIPOVER UNFOLDED
FIG. 20-1

2. Unbolt opener from mounting bracket (shipping position) and save to reinstall (FIG. 20-1).

STEP 2 - WELD LIFTGATE TO VEHICLE - Continued

⚠ CAUTION

To prevent damage to aluminum flipover, NEVER hoist the Liftgate by the flipover. Hoist the Liftgate only by the platform. Refer to the illustrations below for the "INCORRECT WAY" and the "CORRECT WAY".

CAUTION

Correct floor clearance must be maintained when Liftgate is in position and being welded. Maintain distance between vehicle floor and top of main frame at center of main frame as shown in the instructions. Dimension tolerance is $\pm 1/4"$. Never apply force at the ends of the main frame tube to change the floor clearance.

3. Make sure hoist is not set up the incorrect way (FIG. 21-1). Place a "C"-clamp on each side of platform (FIG. 21-1) to prevent hoist chain from slipping off platform. Wrap chain around platform (FIG. 21-1).

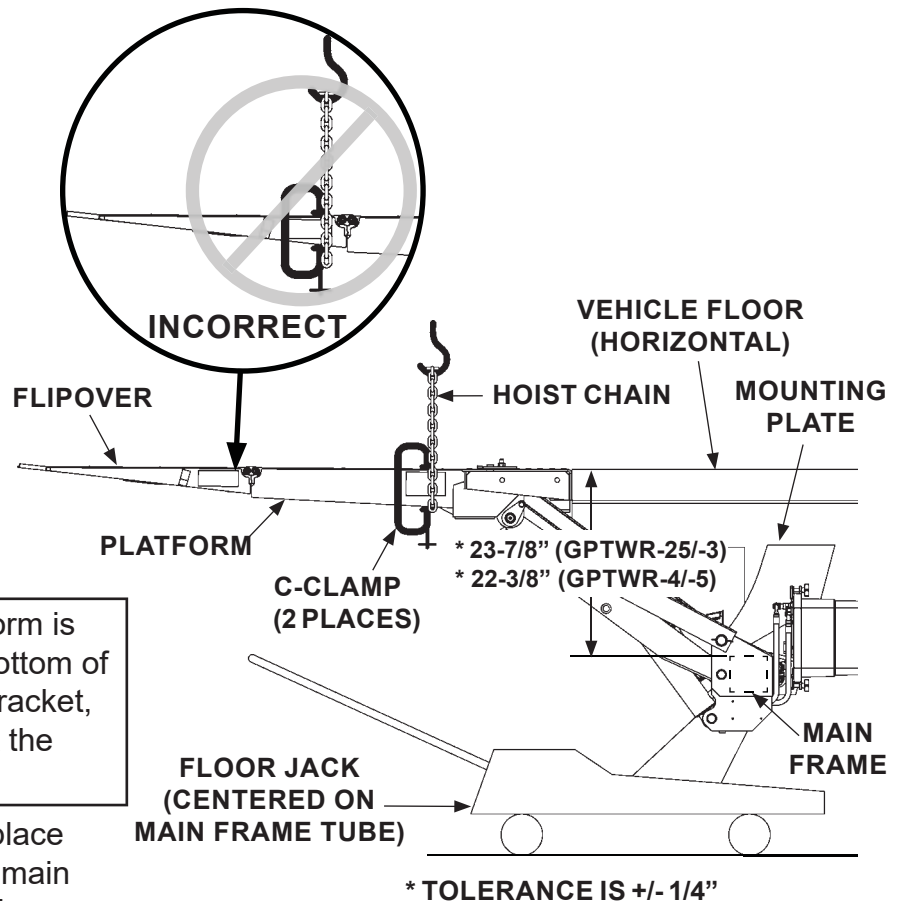

NOTE: Ensure the platform is up against the bottom of the installation bracket, and tight against the dowel.

4. Hoist the Liftgate. Then, place floor jack under center of main frame (FIG. 21-1). Jack the Liftgate into position. Make sure vehicle floor is horizontal. Maintain distance between floor and top of main frame as shown in FIG. 21-1.

* TOLERANCE IS $\pm 1/4"$
CORRECT WAY TO HOIST LIFTGATE
FIG. 21-1

STEP 2 - WELD LIFTGATE TO VEHICLE - Continued

CAUTION

Prevent damage to hydraulic hoses. If welding next to hydraulic hoses, use a protective cover such as a welding blanket to cover the hoses.

CAUTION

To protect the original paint system if equipped, a 3" wide area of paint must be removed from all sides of the weld area before welding.

CAUTION

When using an electric welder, connect the welder ground to one of the parts being welded, as close to the weld as possible. Failure to comply could result in damage to cylinders and electrical parts.

- Clamp both mounting plates to vehicle frame. Check the distance between bed level and top of main frame. Maintain the distance shown in FIG. 22-1.

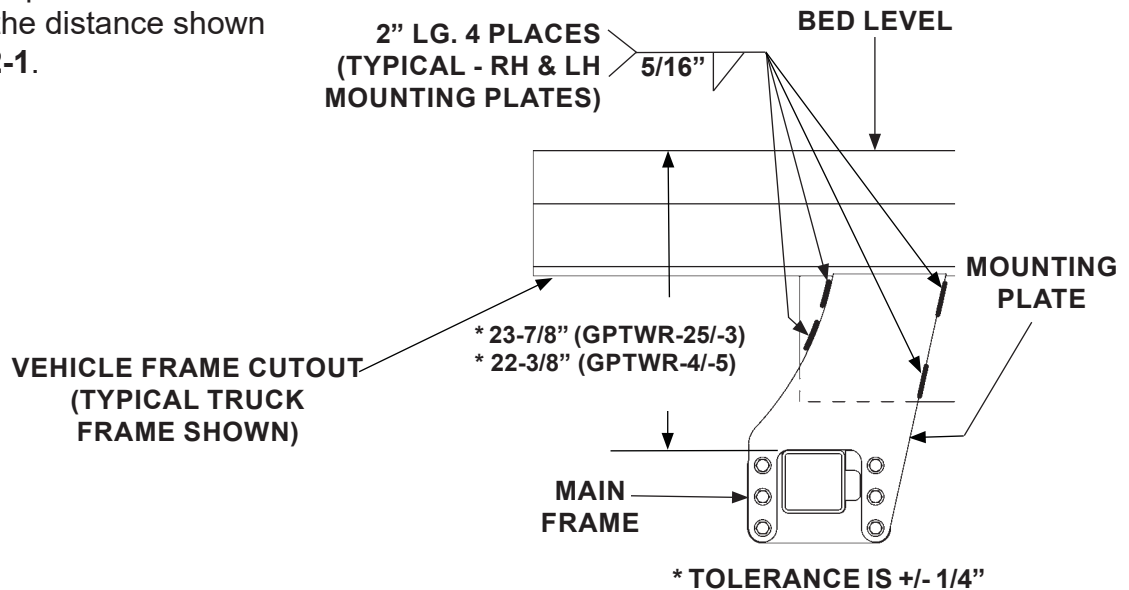

WELD TO VEHICLE FRAME AND MAIN FRAME
(RH SIDE SHOWN)

FIG. 22-1

- Weld the mounting plates to vehicle frame as shown in FIG. 22-1. Remove clamps.

STEP 3 - ATTACH OPTIONAL BATTERY BOX & FRAME TO VEHICLE (IF EQUIPPED)

RECOMMENDED CONFIGURATION

NOTE: Make sure the Liftgate power unit, and all batteries on the vehicle for the power unit, are connected correctly to a common chassis ground.

1. Liftgate and optional battery box are typically installed on trailers as shown in **FIG. 23-1** and on trucks as shown in **FIG. 23-2**. See the following page for battery and cable connections.

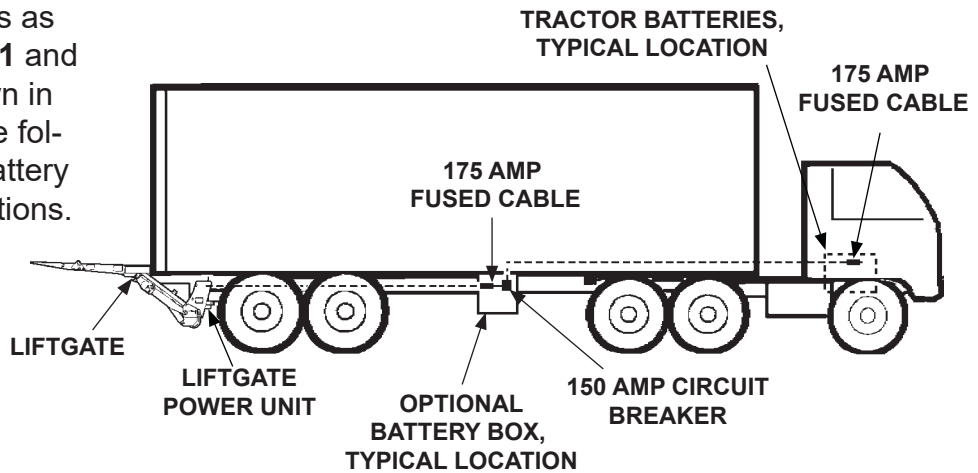

**RECOMMENDED LIFTGATE & OPTIONAL BATTERY BOX
INSTALLATION ON TRAILER
FIG. 23-1**

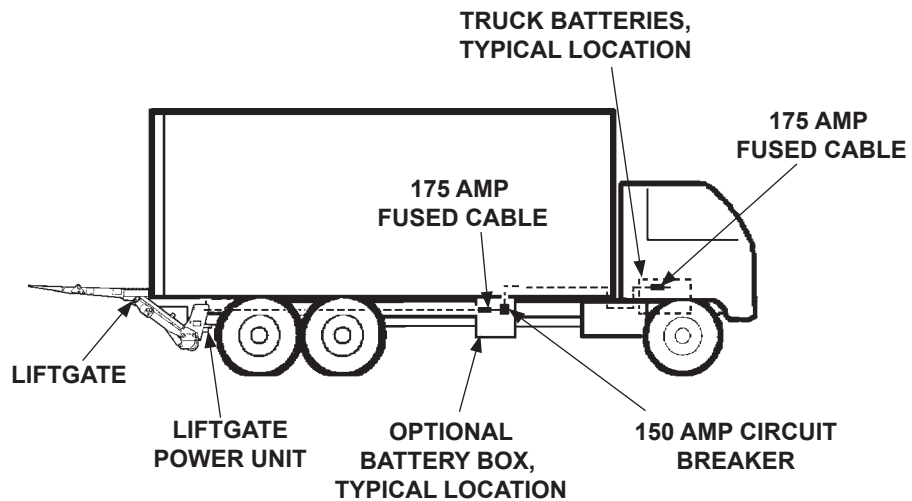

**RECOMMENDED LIFTGATE & BATTERY BOX
INSTALLATION ON TRUCK
FIG. 23-2**

STEP 3 - ATTACH OPTIONAL BATTERY BOX & FRAME TO VEHICLE (IF EQUIPPED) - Continued

2. Select holes on top of battery box frame to align mounting brackets flush to cross members. Refer to **FIGS. 24-1 & 24-1A** for trailers and **FIG. 24-2** for trucks. Bolt mounting brackets to battery box frame as shown in **FIG. 24-1B**. Torque each bolt and lock nut to **85-128 lb-ft.**

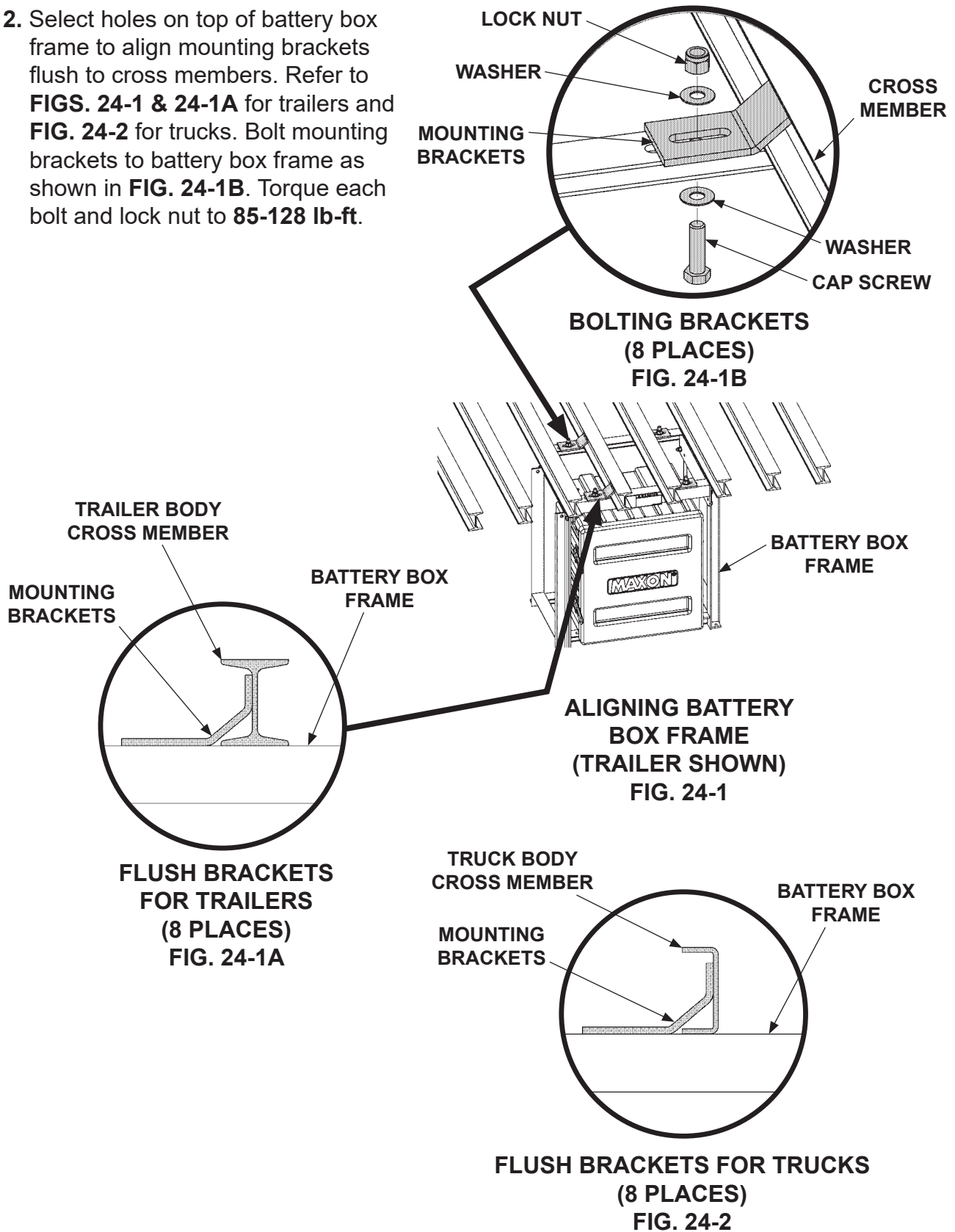

STEP 3 - ATTACH OPTIONAL BATTERY BOX & FRAME TO VEHICLE (IF EQUIPPED) - Continued

NOTE: The hanger brackets for the battery box frame can either be bolted or welded to the cross members of the vehicle body. If welding mounting brackets to cross members, skip instruction 3.

3. To bolt hanger brackets to cross members, use hanger brackets as a template to mark and drill holes through cross members (**FIG. 25-1**). Then, bolt hanger brackets to cross members as shown in **FIGS. 25-2 and 25-2A**. Torque bolts and lock nuts to **85-128 lb-ft**. To weld brackets instead of bolting, weld each hanger bracket to cross member as shown in **FIGS. 26-1 and 26-1A**. Weld top of bracket if accessible.

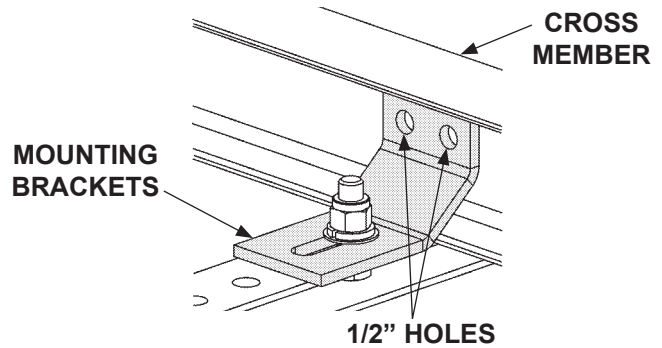

MARK AND DRILL BRACKET HOLES
FIG. 25-1

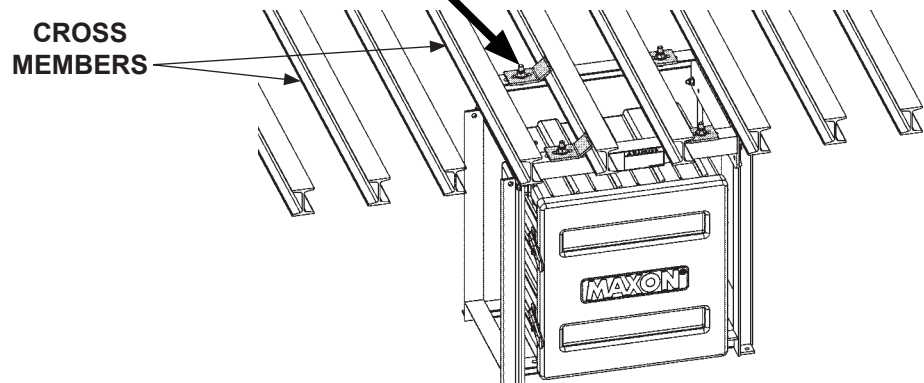
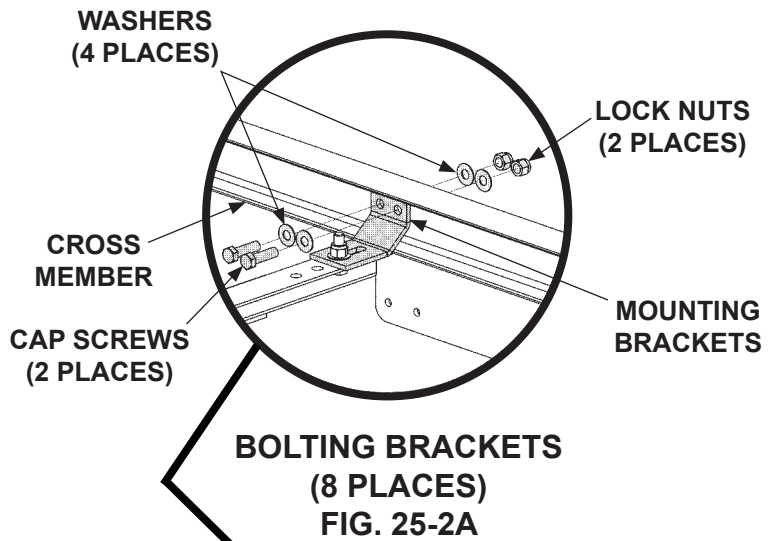

BOLTING BATTERY BOX FRAME
FIG. 25-2

STEP 3 - ATTACH OPTIONAL BATTERY BOX & FRAME TO VEHICLE (IF EQUIPPED) - Continued

⚠ WARNING

Recommended practices for welding on steel parts are contained in the current AWS (American Welding Society) D1.1 Structural Welding Code - Steel. Damage to Liftgate and/or vehicle, and personal injury can result from welds that are done incorrectly.

CAUTION

To prevent pump box components from being damaged by electric current from welding, connect welder grounding cable to the part being welded.

CAUTION

Cover pump box and optional battery box with flame-resistant covering before welding pump box frame to vehicle.

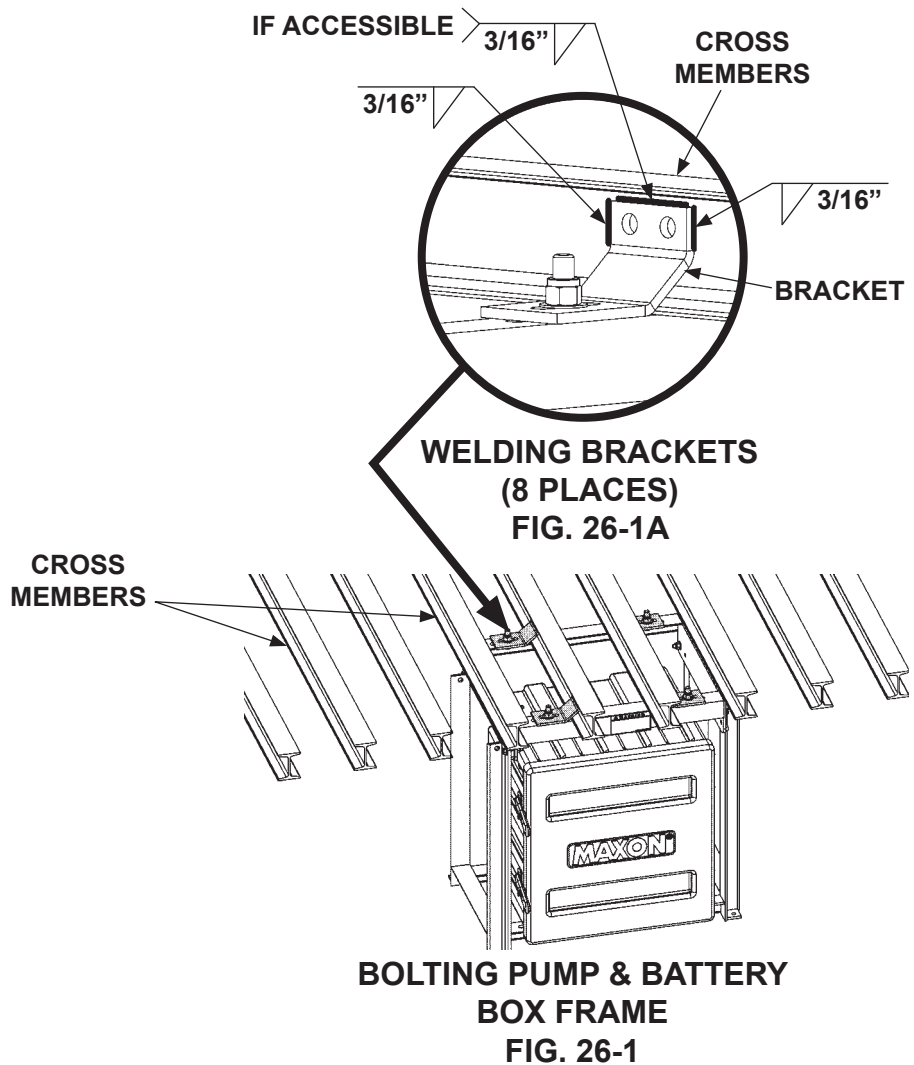

STEP 3 - ATTACH OPTIONAL BATTERY BOX & FRAME TO VEHICLE (IF EQUIPPED) - Continued

⚠ WARNING

Remove all rings, watches and jewelry before doing any electrical work.

NOTE: Always connect fused end of power cable to battery positive (+) terminal.

NOTE: To connect charge lines, refer to instructions provided with each charge line kit.

4. Connect battery cables, fused cables, and ground cables for 12 volt power as shown in **FIG. 27-1** or 24 volt power as shown in **FIG. 28-1**.

GROUND CABLE TO PUMP
BOX OR COMMON CHASSIS
GROUND, 74" LG.
(BATTERY BOX KIT ITEM)

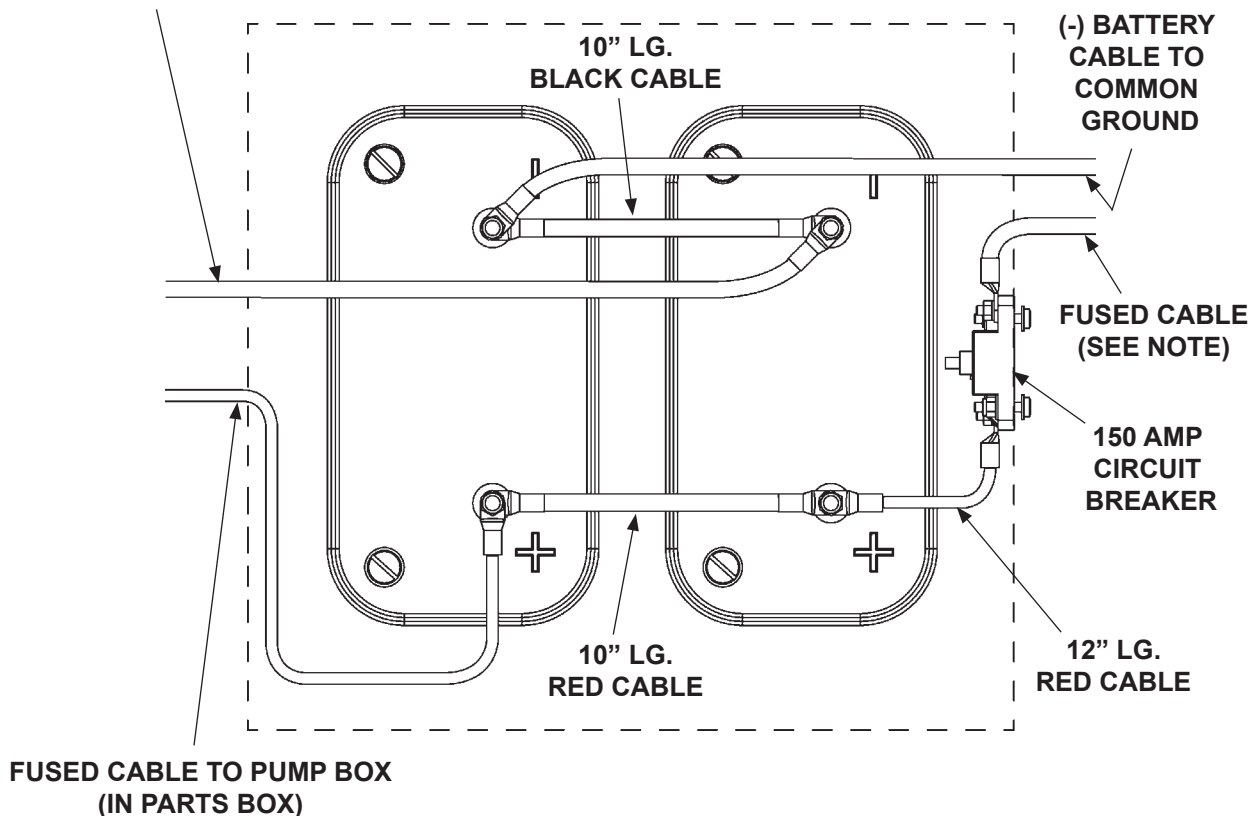

12 VOLT BATTERY CONNECTIONS
FOR 12 VOLT POWER
FIG. 27-1

STEP 3 - ATTACH OPTIONAL BATTERY BOX & FRAME TO VEHICLE (IF EQUIPPED) - Continued

NOTE: Always connect fused end of power cable to battery positive (+) terminal.

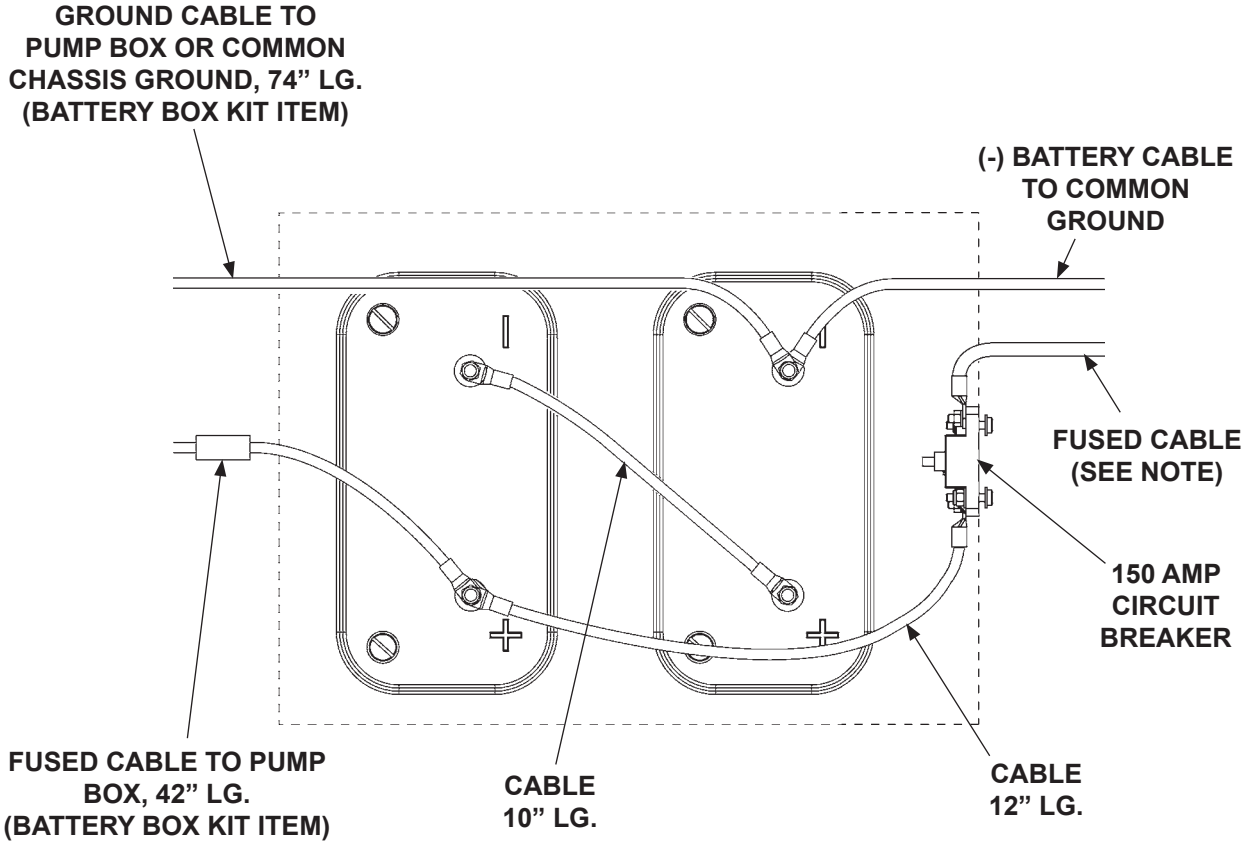

**12 VOLT BATTERY CONNECTIONS FOR 24 VOLT POWER
FIG. 28-1**

STEP 3 - ATTACH OPTIONAL BATTERY BOX & FRAME TO VEHICLE (IF EQUIPPED) - Continued

⚠ WARNING

Explosive hydrogen gas from charging batteries can accumulate in battery box if not vented from the box. To prevent hydrogen gas from accumulating, ensure the 3 ventilation holes in battery box are not plugged or covered.

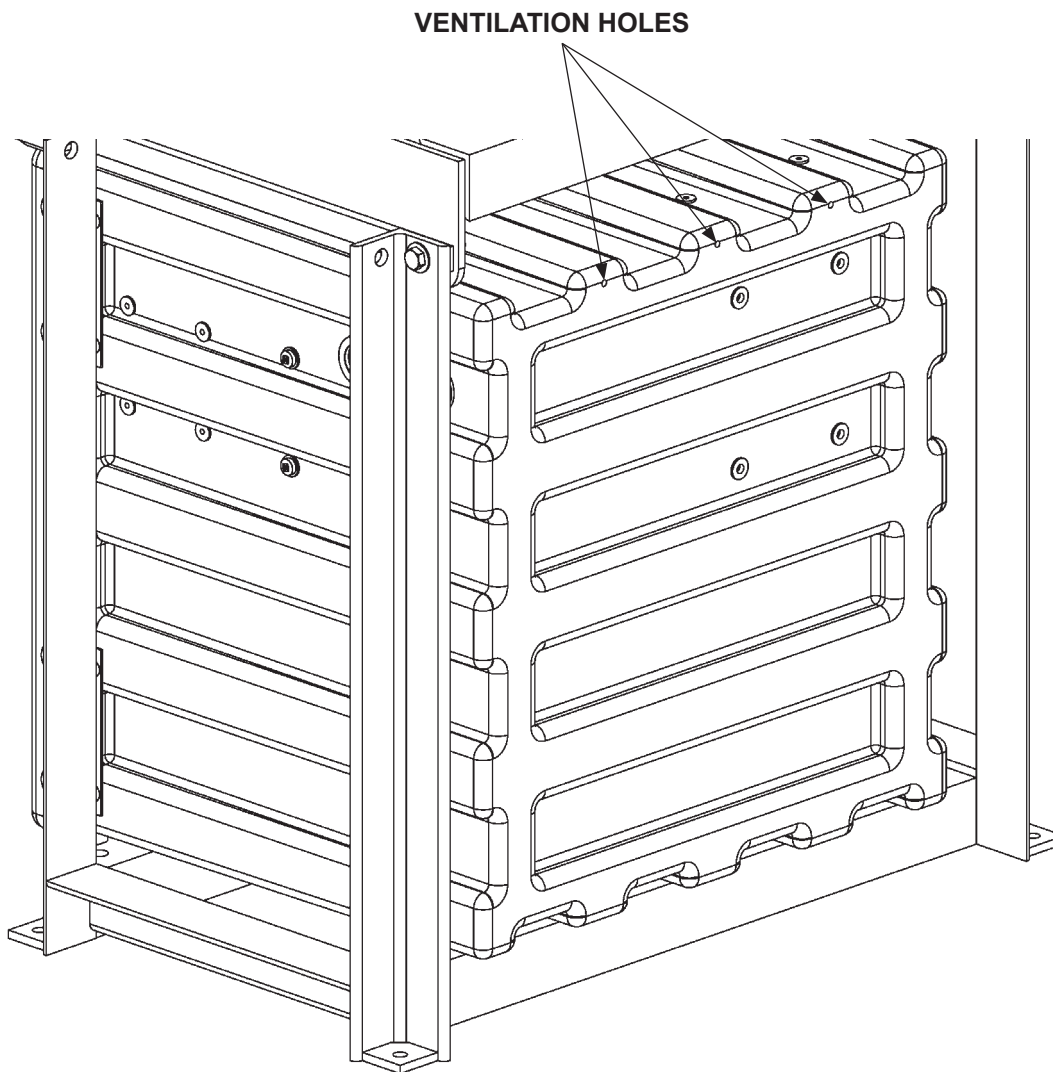

**BATTERY BOX ASSEMBLY
(REAR VIEW SHOWN)
FIG. 29-1**

STEP 3 - ATTACH OPTIONAL BATTERY BOX & FRAME TO VEHICLE (IF EQUIPPED) - Continued

BATTERY BOX ASSEMBLY

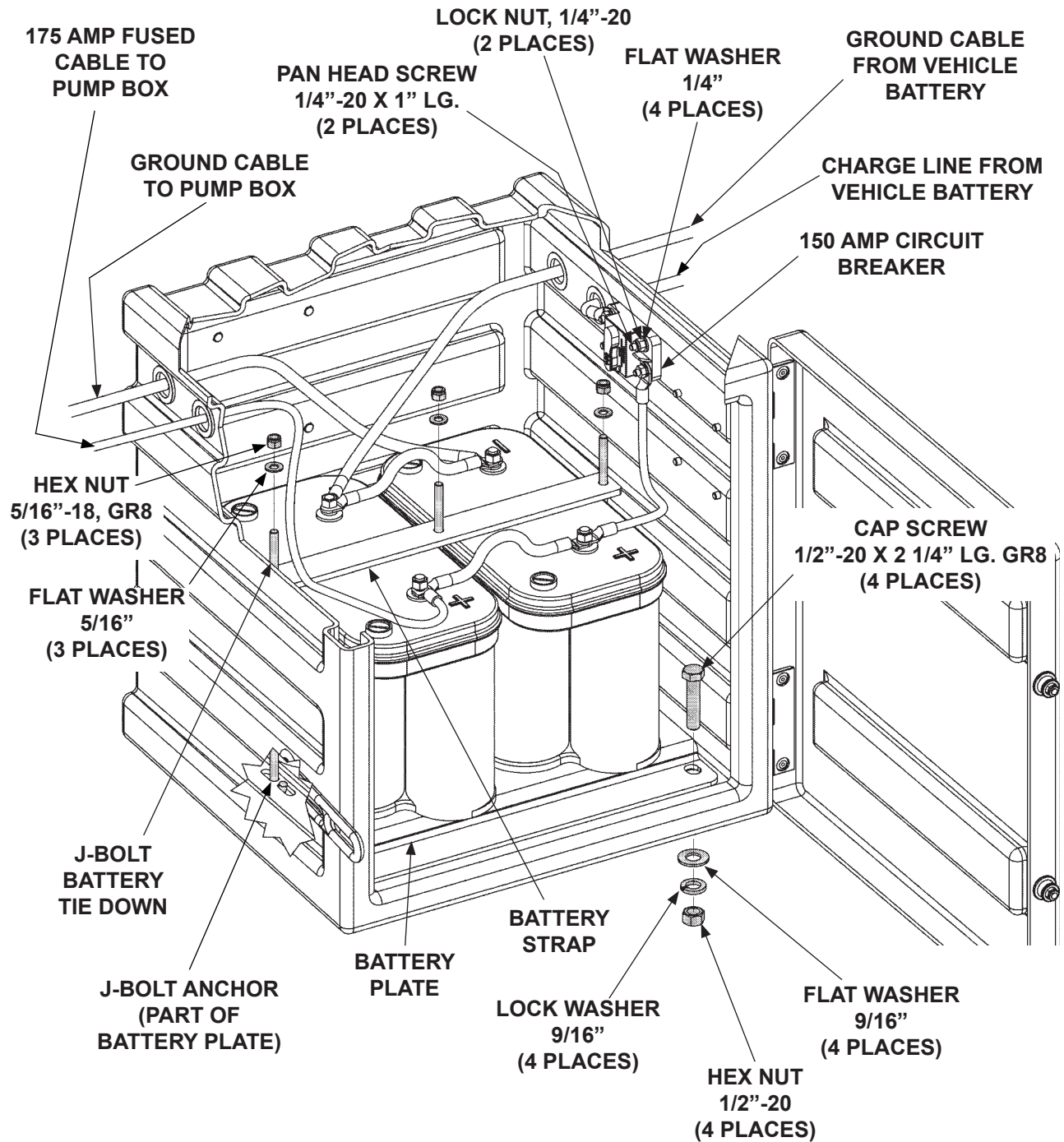

FIG. 30-1

STEP 4 - RUN POWER & GROUND CABLES

NOTE: Make sure the Liftgate power unit, and all batteries on the vehicle for the power unit, are connected correctly to a common chassis ground.

RECOMMENDED CONFIGURATION

1. Liftgate powered from truck batteries is typically installed on trailers as shown in **FIG. 31-1** and on trucks as shown in **FIG. 31-2**. See the following page for running the power cable and dedicated ground cable.

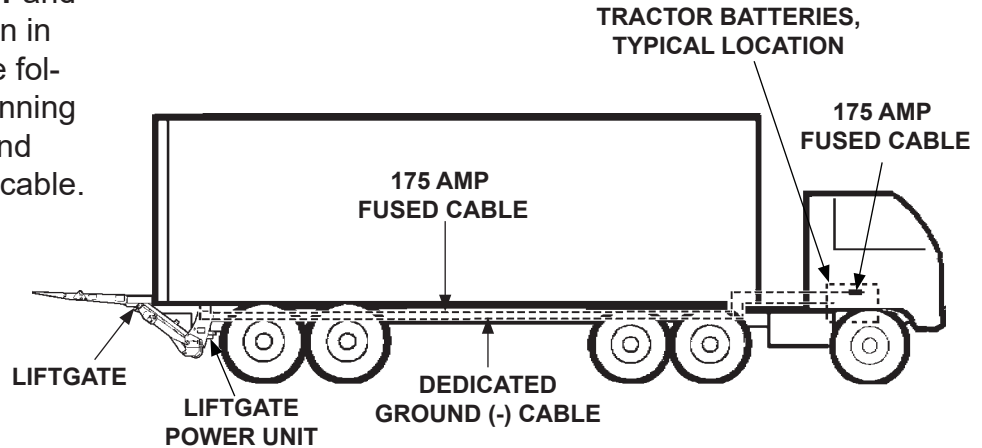

**RECOMMENDED LIFTGATE & POWER CABLE
INSTALLATION ON TRAILER
FIG. 31-1**

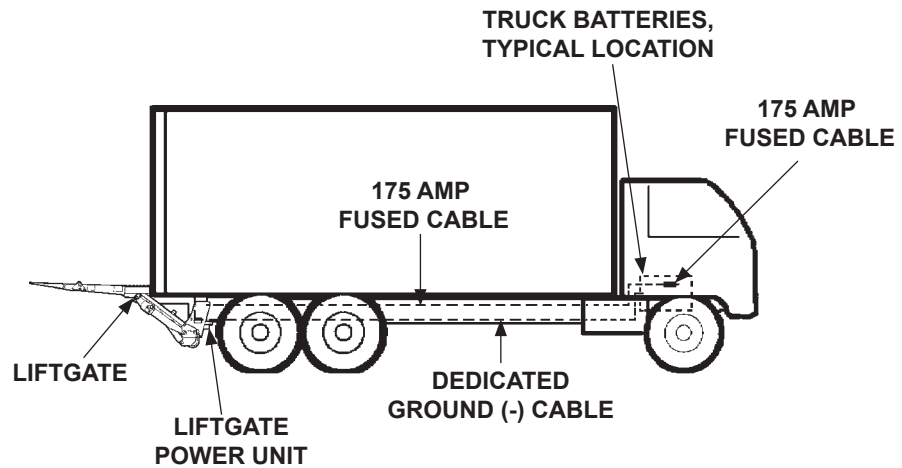

**RECOMMENDED LIFTGATE & POWER CABLE
INSTALLATION ON TRUCK
FIG. 31-2**

STEP 4 - RUN POWER & GROUND CABLES - Continued

⚠ CAUTION

Never route an energized wire. Make sure the vehicle battery is disconnected. Always route electrical wires clear of moving parts, brake lines, sharp edges and exhaust systems. Avoid making sharp bends in wiring. Keep adequate distance between (+) and (-) cables that connect to battery. Attach securely. If drilling is necessary, first check behind the drilling surface so you do not damage any fuel lines, vent lines, brake lines or wires.

NOTE: Parts Boxes A and C contain power and ground cables for connecting battery power to your liftgate, and frame clips and plastic ties for securing the cables to the vehicle frame.

NOTE: Make sure Liftgate power unit, and all batteries on the vehicle for power unit, are connected correctly to vehicle common chassis ground. If using the dedicated 38 foot long ground cable, ensure cable is connected to battery (-) terminal (**STEP 9**).

2. Clip fused power (+) cable, at intervals shown in **FIG. 32-1**, to vehicle frame with fuse nearest the vehicle battery. Keep enough cable near the battery to reach the positive terminal without straining cable (after connection). Run power (+) cable to pump box on Liftgate. Run the 38-ft. long ground (-) cable along vehicle frame from the vehicle battery to the rear of vehicle where Liftgate will be mounted. Clip ground (-) cable to vehicle frame at intervals shown **FIG. 32-1**. Use plastic ties where needed.

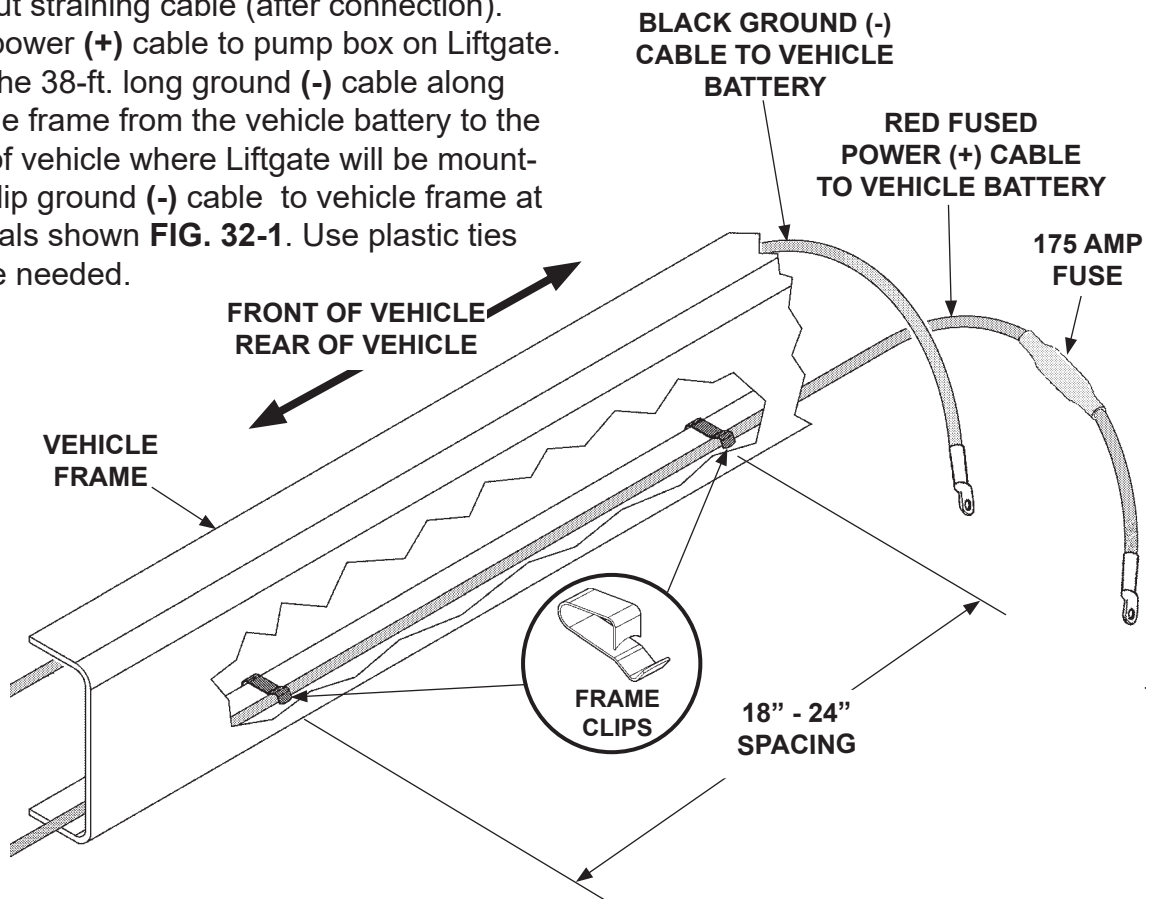

**RUNNING POWER & GROUND CABLES TO TAIL LIFT ON TRUCK
FIG. 32-1**

STEP 5 - CONNECT POWER CABLE

1. Unbolt and remove pump cover (FIG. 33-1).

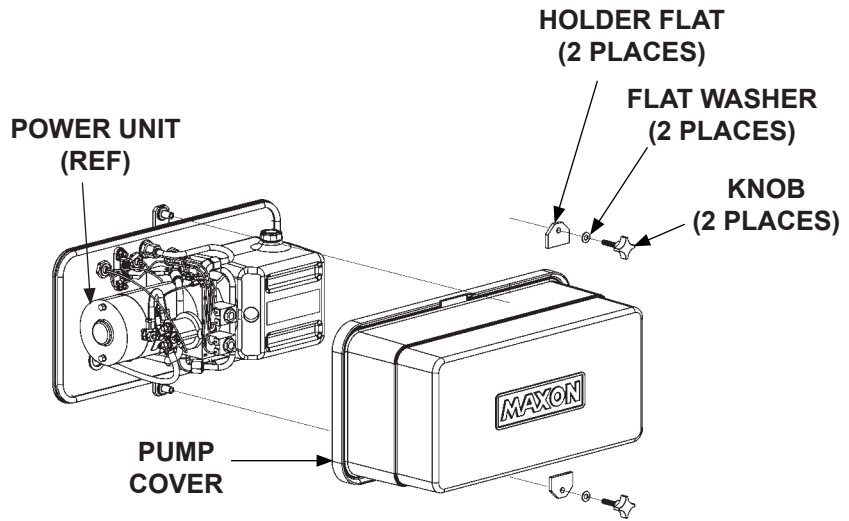

UNBOLTING PUMP COVER
FIG. 33-1

2. On the bare wire end of fused power cable, keep enough length to attach copper terminal lug and reach motor solenoid switch (single pump) or pump selector switch (dual pumps) without putting tension on cable (after connection) (FIG. 33-2). Measure (if needed), and then cut excess cable from bare wire end of cable. Put heat shrink tubing (parts bag item) (FIG. 33-2A) on the end of the cable and leave room for terminal lug. Crimp copper terminal lug (parts bag item) on the fused power cable and shrink the heat shrink tubing (FIG. 33-2B).

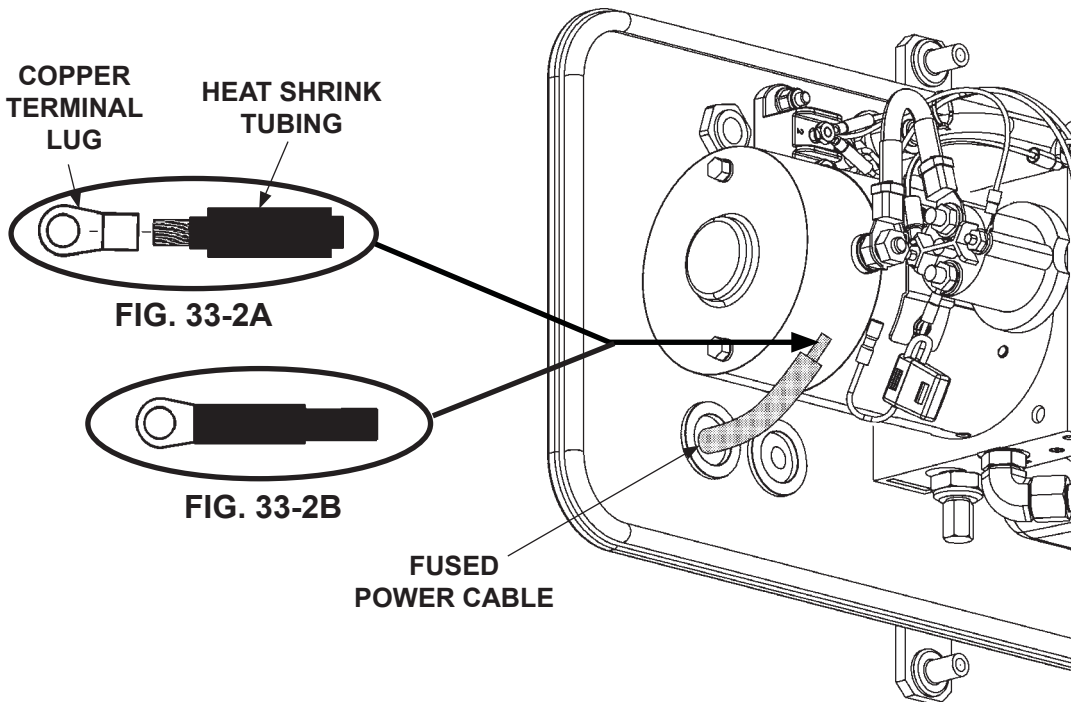

TYPICAL FUSED POWER CABLE ROUTING
FIG. 33-2

STEP 5 - CONNECT POWER CABLE - Continued

CAUTION

Do not over-tighten the terminal nuts on solenoid switch. For the load terminals, torque nuts to 35 lb-in max. Torque the nuts on #10-32 control terminals to 15 lb-in.

NOTE: Form a drip loop in the fused power cable where it enters the power unit on the outside of the pump mounting plate.

NOTE: Do not remove flat washer from the battery power terminal.

NOTE: For **dual pump configuration**, skip instruction 3 and complete instruction 4.

3. Remove hex nut and lock washer from battery power terminal on the solenoid switch. Remove fuse holder assembly. Connect the power cable and fuse holder assembly to the solenoid switch as shown in **FIG. 34-1**. Reinstall and tighten lock washer and hex nut.

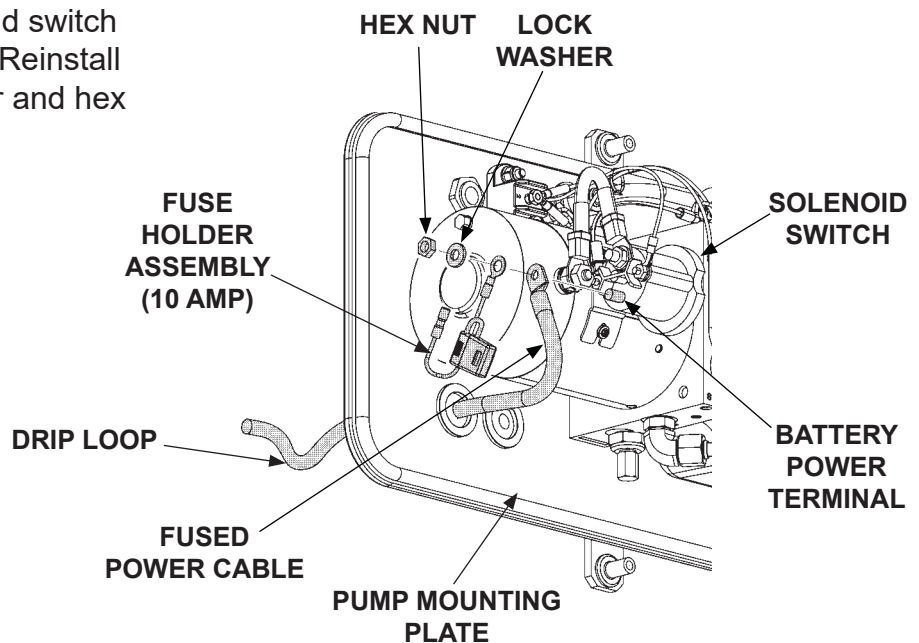

TYPICAL FUSED POWER
CABLE ELECTRICAL CONNECTION
FIG. 34-1

STEP 5 - CONNECT POWER CABLE - Continued

4. Remove hex nut and lock washer from OUTPUT terminal on pump selector switch. Connect fused power cable to OUTPUT terminal on pump selector switch as shown in FIG. 35-1 & FIG. 35-1A. Reinstall and tighten lock washer and hex nut.

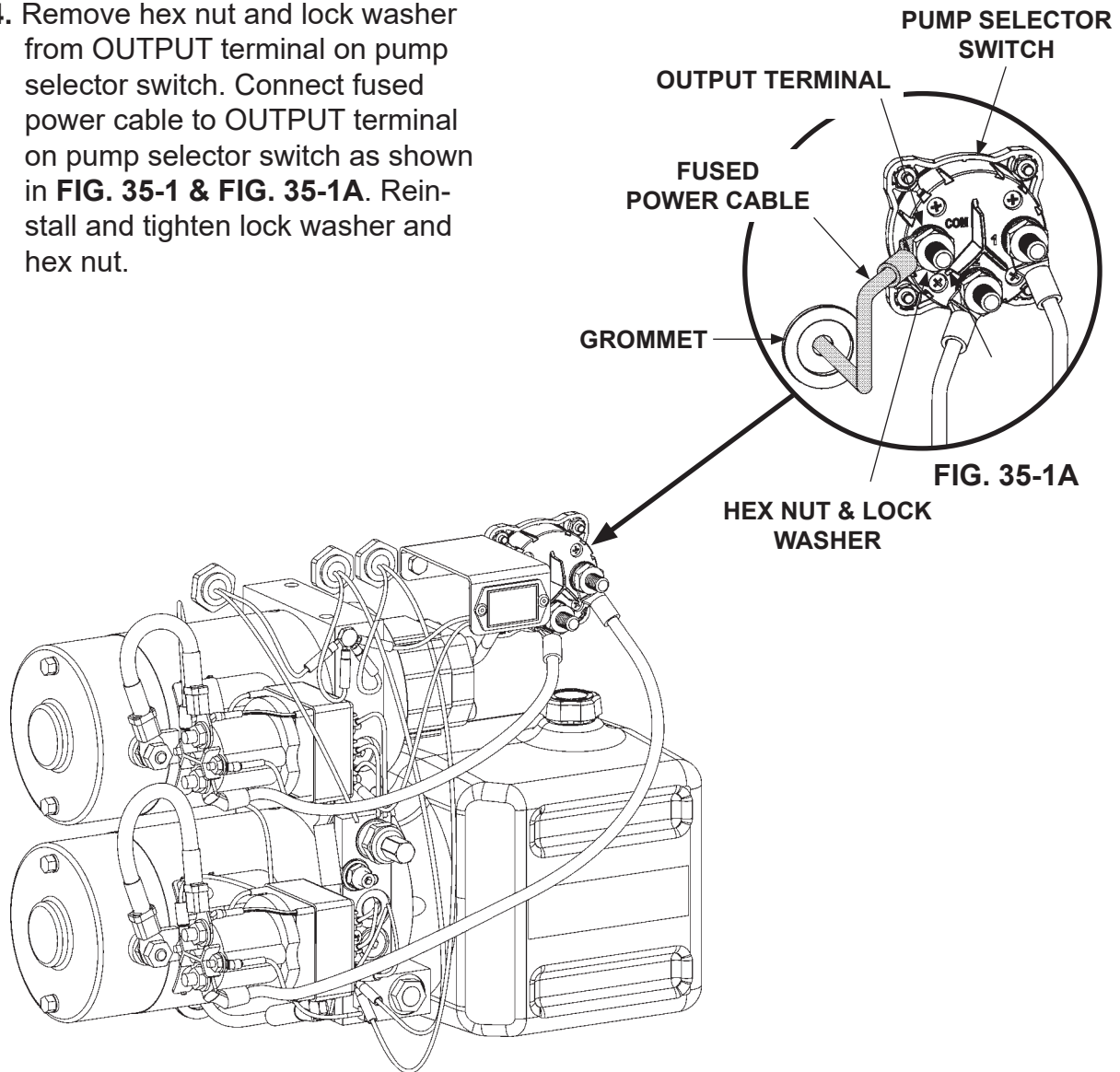

**TYPICAL FUSED POWER
CABLE ELECTRICAL CONNECTION - DUAL PUMPS**
FIG. 35-1

STEP 6 - CONNECT GROUND CABLE

NOTE: To ensure power unit is correctly grounded, connect 2 gauge ground cable from grounding connection on pump mounting plate to a grounding point on the frame, or negative battery terminal in the optional battery box. Refer to **STEP 9** to connect a dedicated 38 foot long ground cable to vehicle battery.

NOTE: Electrical lines must be run into pump box through sealing grommets (**FIG. 36-1A**). To ensure a good seal on the electrical lines, never cut the sealing grommets.

1. Insert external ground cable (Parts Box A or C) through grommet on pump mounting plate (**FIGS. 36-1 and 36-1A**).
2. Bolt ground cable to ground connection on pump using existing bolt (**FIGS. 36-1 and 36-1B**).
3. Form a drip loop on the ground cable where it enters the grommet from outside the pump mounting plate (**FIGS. 36-1, 36-1B & 36-1C**).

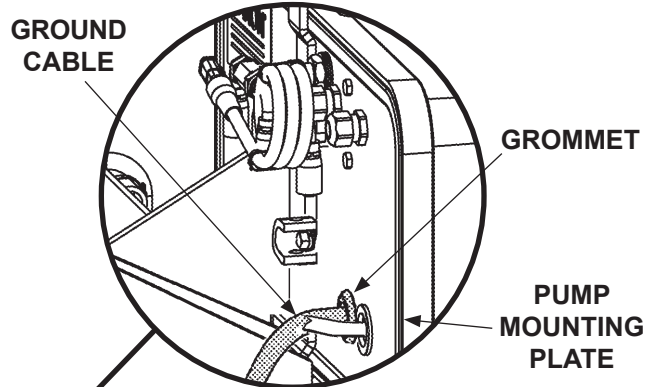

GROUND CABLE INSERTED THROUGH GROMMET
FIG. 36-1A

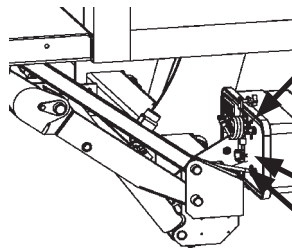
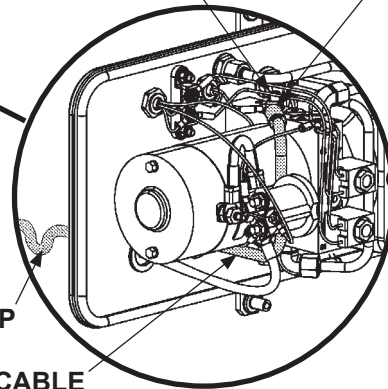
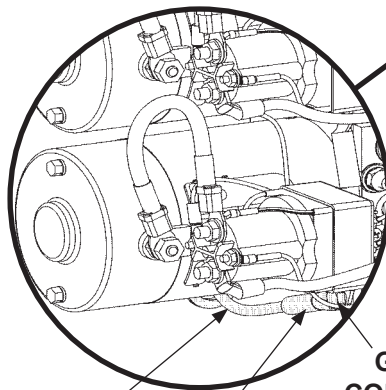

FIG. 36-1

GROUND CONNECTION WITH BOLT
GROUND CABLE TERMINAL LUG



BOLTING GROUND CABLE TO SINGLE PUMP
FIG. 36-1B



BOLTING GROUND CABLE TO DUAL PUMP
FIG. 36-1C

STEP 6 - CONNECT GROUND CABLE - Continued

NOTE: If there is a grounding point on the frame, use it to connect ground cable. Then, skip the step for drilling a hole.

NOTE: Clean the ground cable connection point on the frame down to bare metal.

4. Extend the ground cable to reach vehicle frame (**FIG. 37-1**) without putting tension on cable (after connection). Connect to an existing grounding point if available.

5. If necessary, drill a 11/32" (0.343") hole in vehicle frame for bolting the ground cable terminal lug (**FIG. 37-1**).

6. To prevent corrosion, paint or use galvanized spray on bare metal area **FIG. 37-1**.

7. Bolt the ground cable terminal lug to vehicle frame with cap screw, flat washer and locknut from Parts Box A (**FIG. 37-1**).

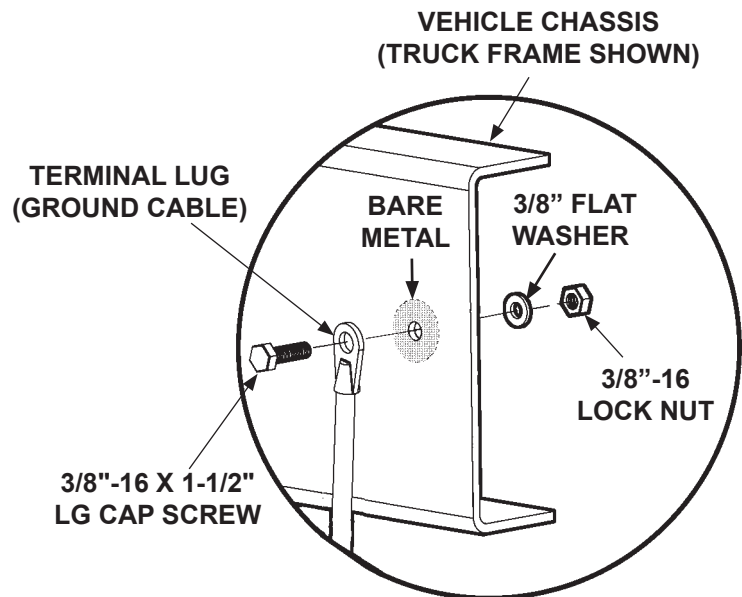
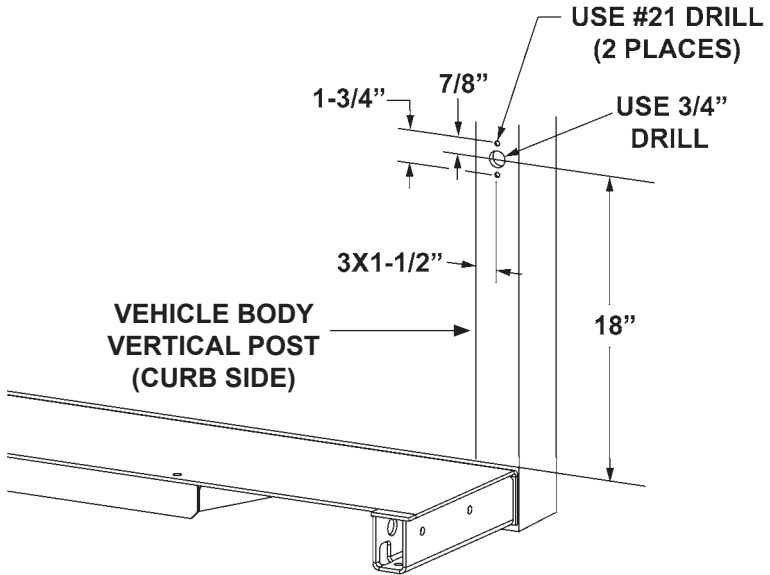

FIG. 37-1

STEP 7 - INSTALL CONTROL SWITCH

1. Drill one 3/4" hole and two #21 (.159) size holes in the vertical post on curb side of vehicle body as shown in **FIG. 38-1**.



**DRILLING MOUNTING HOLES
FIG. 38-1**

STEP 7 - INSTALL CONTROL SWITCH - Continued

NOTE: Form a drip loop in the control switch cable where it enters the power unit on the outside of the pump mounting plate.

2. Insert control switch cable into the 3/4" hole on the corner post and run it under the vehicle body to the pump assembly. (See dashed line - FIG. 39-1.) Insert switch cable through cord grip on pump mounting plate (FIG. 39-2). Connect the switch wiring to the pump assembly as shown in (FIG. 39-2).

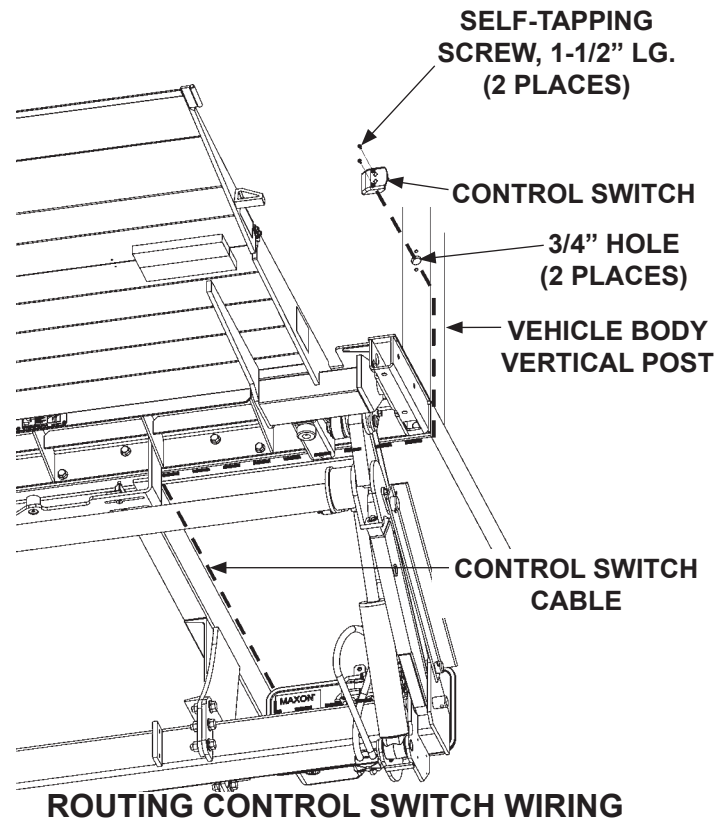

3. Push control switch and cable back into the 3/4" hole in the vertical post until control switch cover touches the post (FIG. 39-1). Attach control switch to vertical post with 2 self-tapping screws (FIG. 39-1).

4. If necessary, use clamps and self-tapping screws, from installation parts bag, to secure switch cable to vehicle (FIG. 39-1).

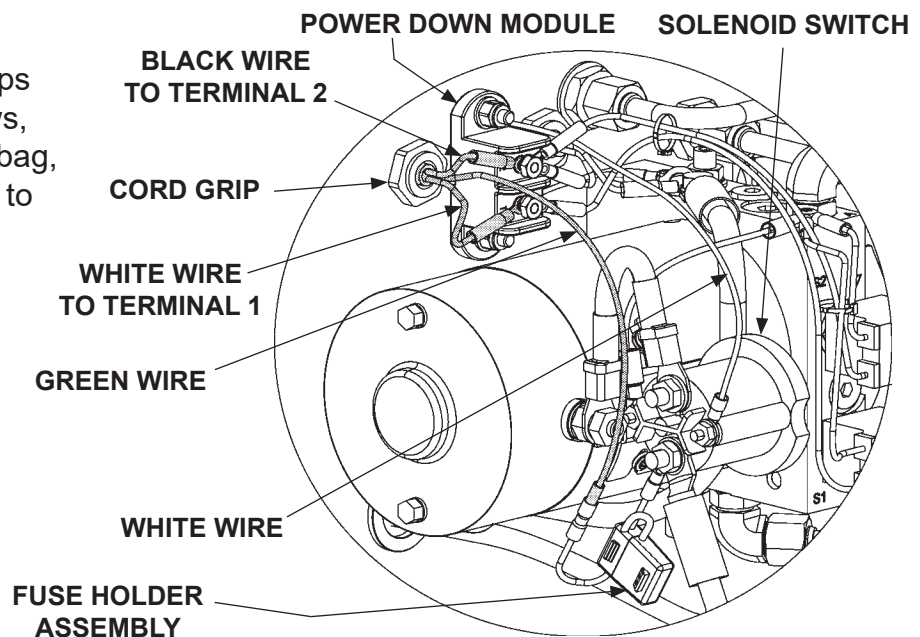

CONTROL SWITCH WIRING CONNECTIONS
FIG. 39-2

STEP 8 - CHECKING HYDRAULIC FLUID

CAUTION

Keep dirt, water and other contaminants from entering the hydraulic system. Before opening the hydraulic fluid reservoir filler cap, drain plug and hydraulic lines, clean up contaminants that can get in the openings. Also, protect the openings from accidental contamination.

NOTE: Liftgate is shipped with ISO 32 hydraulic fluid. Use correct hydraulic fluid for climate conditions.

+50 to +120 Degrees F - Grade ISO 32

Below + 70 Degrees F - Grade ISO 15 or MIL-H-5606

See TABLES 41-1 & 41-2 for recommended brands.

1. Check the hydraulic fluid level in reservoir with Liftgate stowed, or platform at vehicle bed height.

NOTE: Information for checking OIL LEVEL is shown on a decal on the pump reservoir.

2. Check if hydraulic oil level is in the range shown on decal (FIG. 40-1). If necessary, remove filler cap (FIG. 40-1) and add hydraulic oil until level rises within the range on decal (FIG. 40-1). Then, reinstall filler cap (FIG. 40-1).

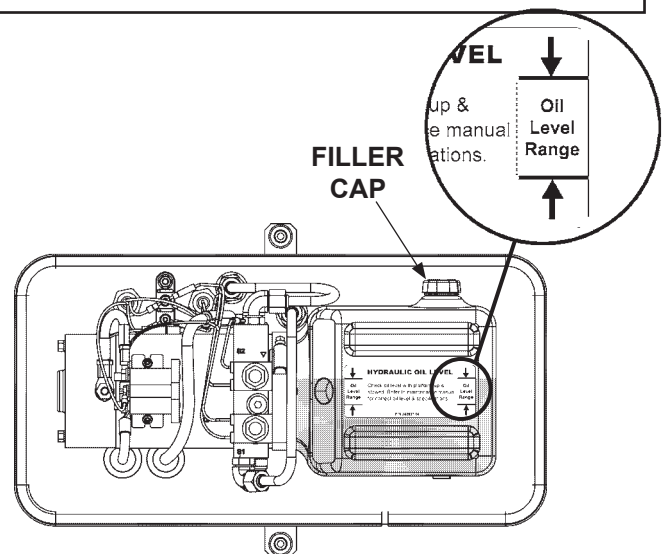

POWER UNIT FLUID LEVEL
FIG. 40-1

CAUTION

Pump cover must be correctly secured to prevent it from becoming a hazard. To secure pump cover, the long side of the holder flats must butt against pump cover as shown in the illustration.

3. Bolt on the pump cover as shown in FIG. 40-2. Hand tighten the threaded cover knobs.

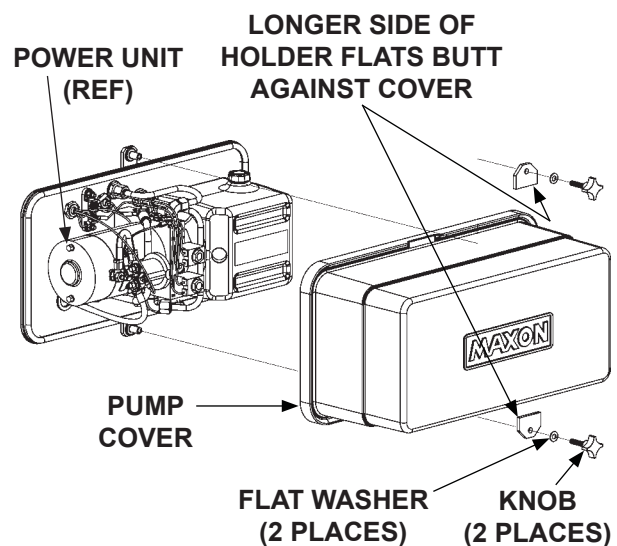

BOLTING ON PUMP COVER
FIG. 40-2

STEP 8 - CHECKING HYDRAULIC FLUID - Continued

ISO 32 HYDRAULIC OIL	
RECOMMENDED BRANDS	PART NUMBER
ROSEMEAD	ROSEMEAD MV150
EXXONMOBIL	MOBIL DTE 10 EXCEL 32
EXXONMOBIL	UNIVIS N-32, DTE-24
CHEVRON	CHEVRON AV MV32
CHEVRON	HIPERSYN 32
U.S. PRESTIGE	PRESTIGE AW HVI 32
KENDALL	GOLDEN MV
SHELL	TELLUS S2 VX 32

TABLE 41-1

ISO 15 OR MIL-H-5606 HYDRAULIC OIL	
RECOMMENDED BRANDS	PART NUMBER
CHEVRON	FLUID A, AW-MV-15
KENDALL	GLACIAL BLU
SHELL	TELLUS S2 VX 15
EXXONMOBIL	UNIVIS HVI-13
PHILLIPS 66	ARCTIC LOW POUR
ROSEMEAD	THS FLUID 17111

TABLE 41-2

STEP 9 - CONNECT POWER & GROUND CABLES TO BATTERY

1. Remove nut from negative (-) battery terminal (FIG. 42-1). Disconnect negative (-) battery cable (FIG. 42-1).

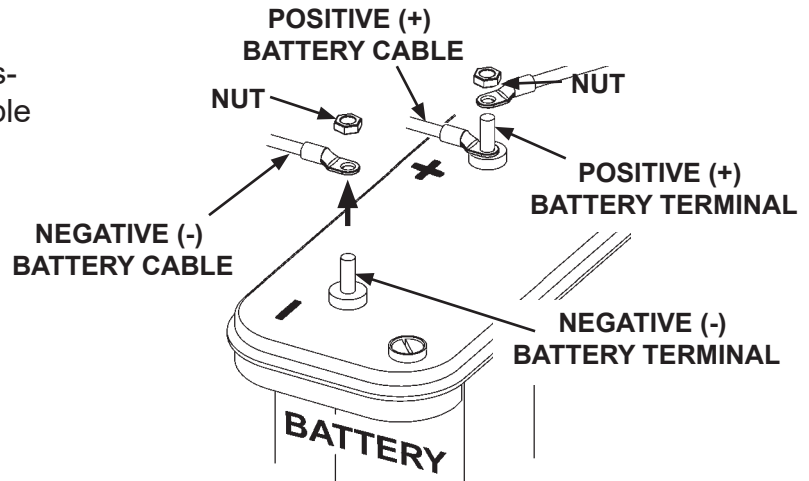

DISCONNECTING (-) BATTERY CABLE
FIG. 42-1

2. Remove nut from positive (+) battery terminal (FIG. 42-1).

3. Connect fused positive (+) cable to positive (+) battery terminal (FIG. 42-2). Then, reinstall nut on positive (+) battery terminal (FIG. 42-2).

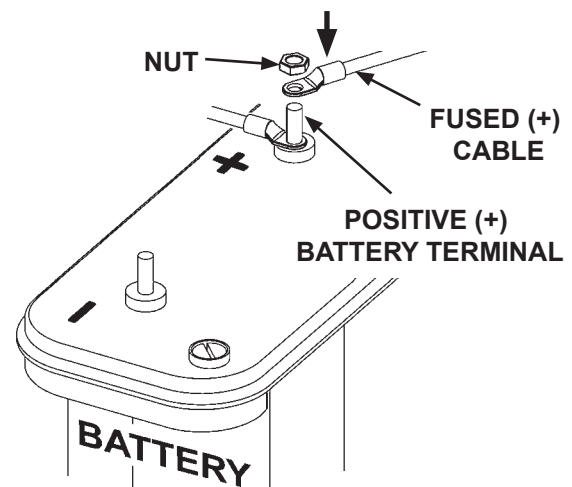

CONNECTING FUSED (+) CABLE
FIG. 42-2

4. Reconnect negative (-) battery cable to negative (-) battery terminal (FIG. 42-3). If dedicated ground (-) cable was installed, connect ground (-) cable to negative (-) battery terminal (FIG. 42-3). Then, reinstall nut on negative (-) battery terminal (FIG. 42-3).

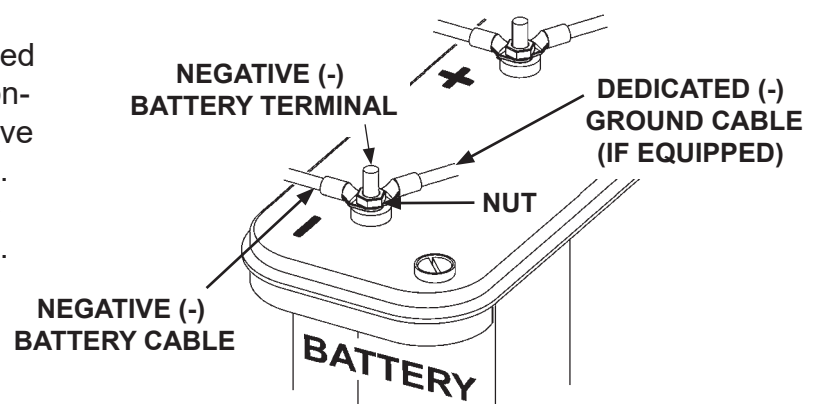

RECONNECTED BATTERY CABLES
FIG. 42-3

STEP 10 - REMOVE LOCKING ANGLES & KNUCKLE BOLTS, CHECK FOR INTERFERENCE

CAUTION

Check for leaking hydraulic fluid as the system is being pressurized. If there is leakage, stop & correct the problem before fully pressurizing the system.

1. Push control switch to **UP** position to pressurize hydraulic system. Listen for hydraulic fluid flowing through the system. Check for fluid leaks. When the sound of flowing fluid stops, release control switch. Hydraulic system is ready.

NOTE: To operate Liftgate, locking angles must be removed from the lift arms and shipping bolt must be removed from both knuckles.

2. Remove locking angles from lift arms (**FIG. 43-1**).
3. With platform open (**FIG. 43-1**), unbolt each knuckle as shown in **FIG. 43-1A**.

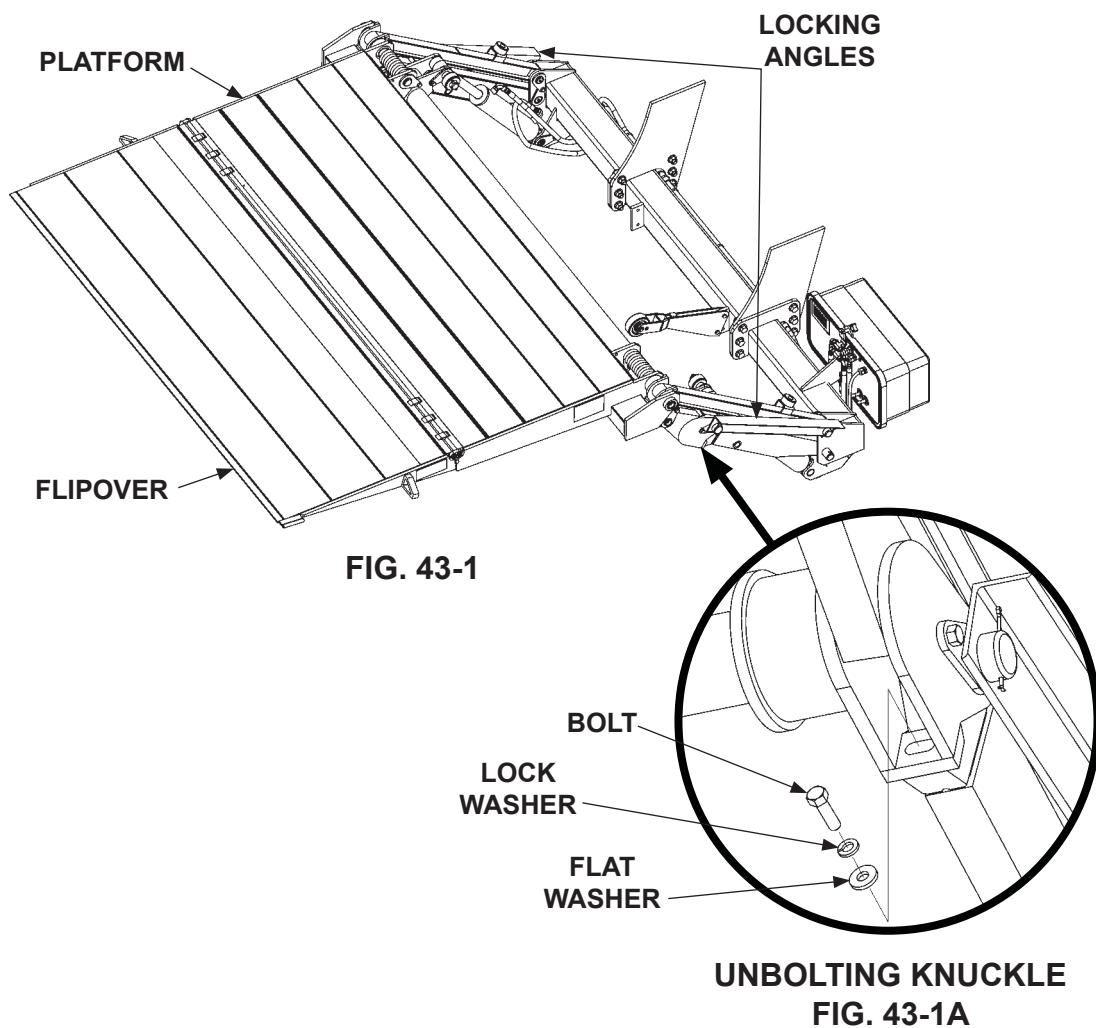

STEP 10 - REMOVE LOCKING ANGLES & KNUCKLE BOLTS, CHECK FOR INTERFERENCE - Continued

4. Remove floor jack and hoist supporting Liftgate (FIG. 44-1).

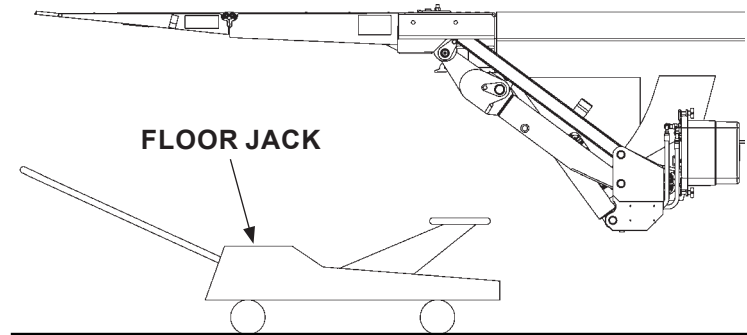

REMOVING JACK
FIG. 44-1

5. Lower platform to the ground (FIG. 44-2). Look for any interference between liftgate and vehicle as platform is lowered. If the platform lowers with a "jerking" motion, bleed air from the hydraulic system by doing the following. Push the control switch to the **DOWN** position until you hear air escaping into the hydraulic fluid reservoir. Make sure the oil is not aerated. Then, raise the platform (FIG. 44-3). Look for any interference between liftgate and vehicle as platform is raised. Repeat step until there is no air left in the system and platform lowers smoothly (FIG. 44-3).

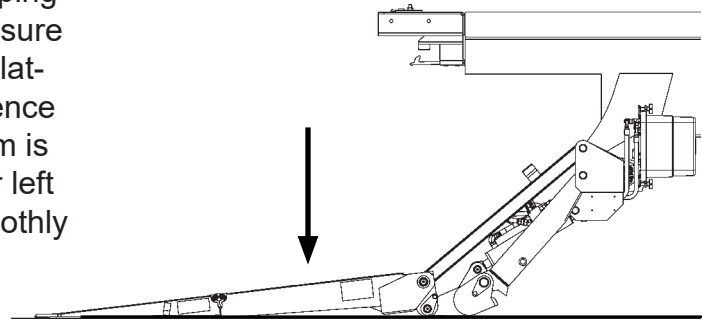

LOWERING PLATFORM
FIG. 44-2

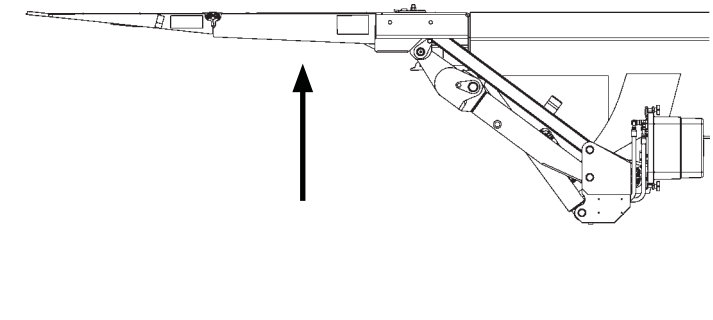

RAISING PLATFORM
FIG. 44-3

STEP 10 - REMOVE LOCKING ANGLES & KNUCKLE BOLTS, CHECK FOR INTERFERENCE - Continued

6. Lower platform to the ground (FIG. 45-1).

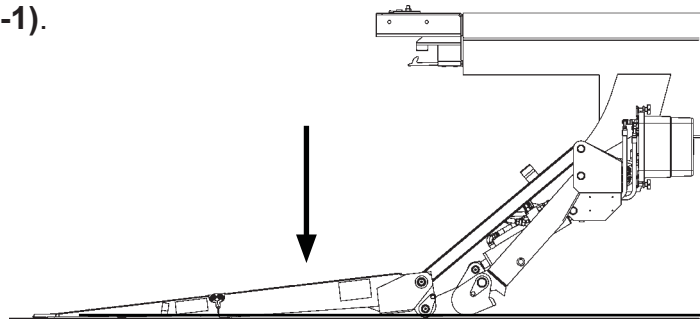

**LOWERING PLATFORM
FIG. 45-1**

7. Unbolt the 2 installation brackets from extension plate (FIG. 45-2).

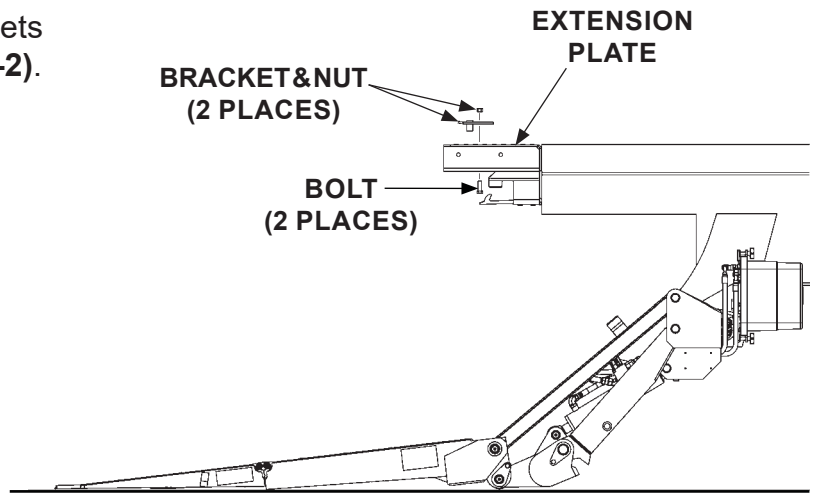

**REMOVING INSTALLATION BRACKETS
FIG. 45-2**

STEP 10 - REMOVE LOCKING ANGLES & KNUCKLE BOLTS, CHECK FOR INTERFERENCE - Continued

NOTE: Correct any fit and interference problems before continuing with installation.

8. Raise the platform to vehicle floor level (FIG. 46-1). (Refer to GPT Series OPERATION MANUAL.) Check for 5/8" gap between platform and edge of extension plate (FIG. 46-1).

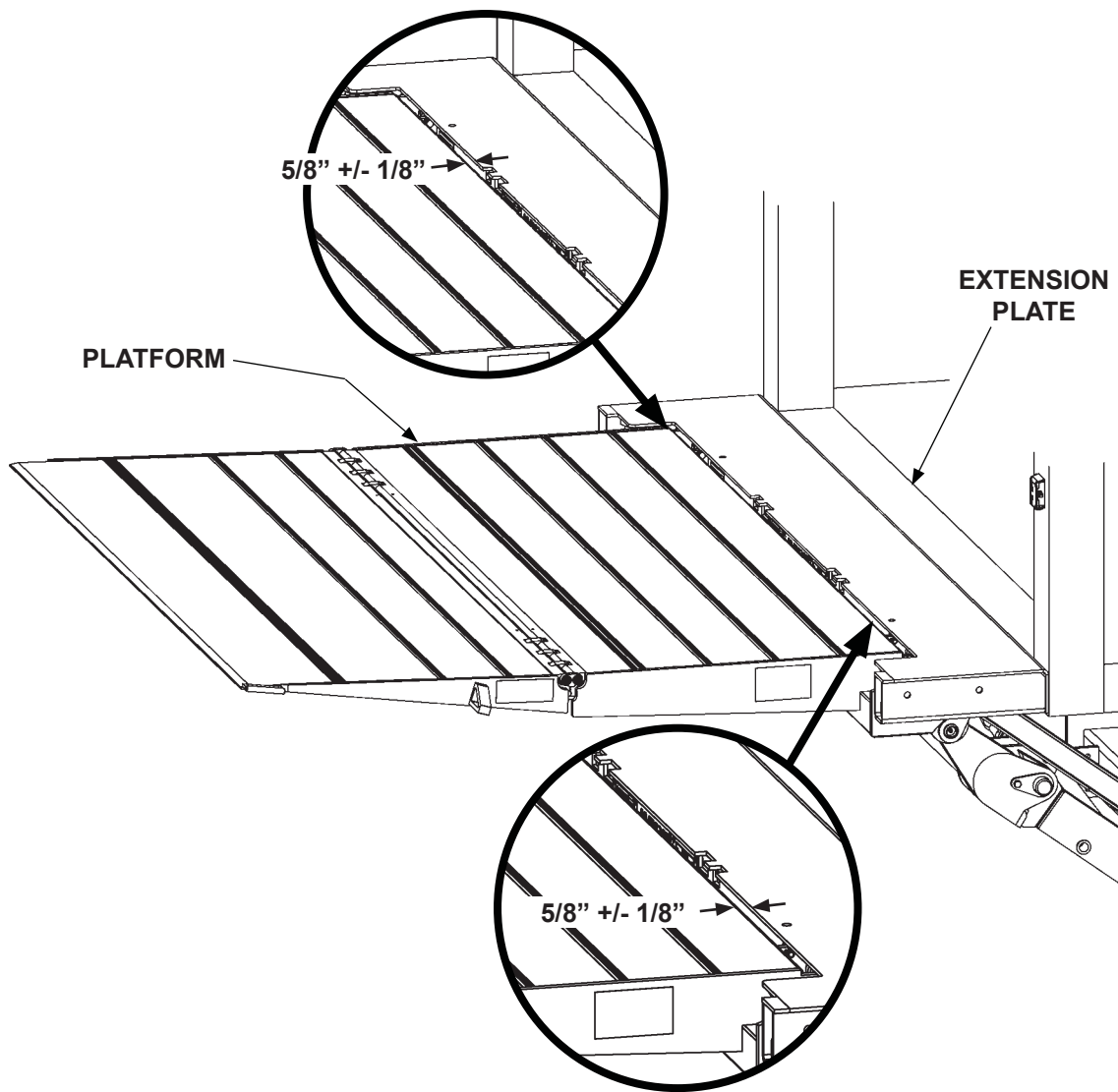

CHECKING GAP BETWEEN PLATFORM
AND EXTENSION PLATE
FIG. 46-1

STEP 10 - REMOVE LOCKING ANGLES & KNUCKLE BOLTS, CHECK FOR INTERFERENCE - Continued

NOTE: Correct any fit and interference problems before continuing with installation.

9. Ensure top surface of platform and extension plate are flush at the RH & LH sides of platform (FIGS. 47-1 and 47-2). The allowable difference in height is $\pm 1/8$ " maximum as shown.

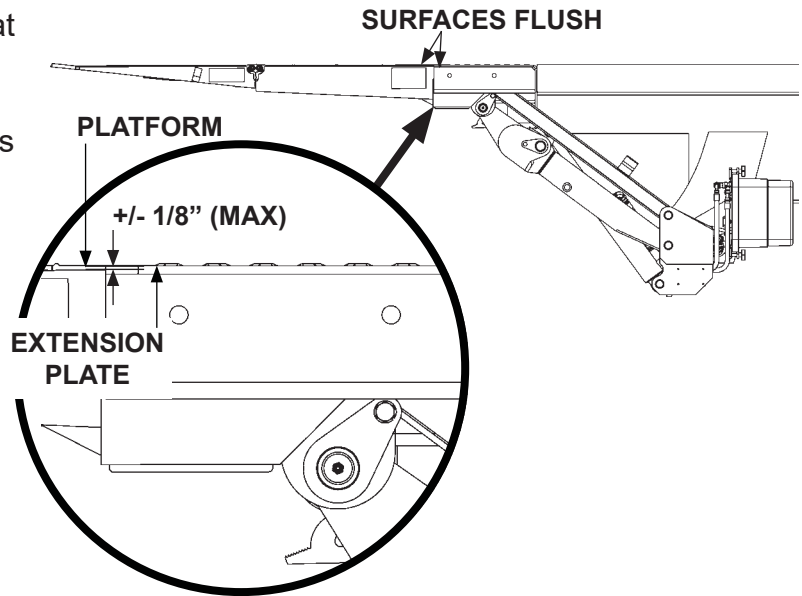

DIFFERENCE IN HEIGHT FOR TOP OF PLATFORM & EXTENSION PLATE (RH VIEW)
FIG. 47-1

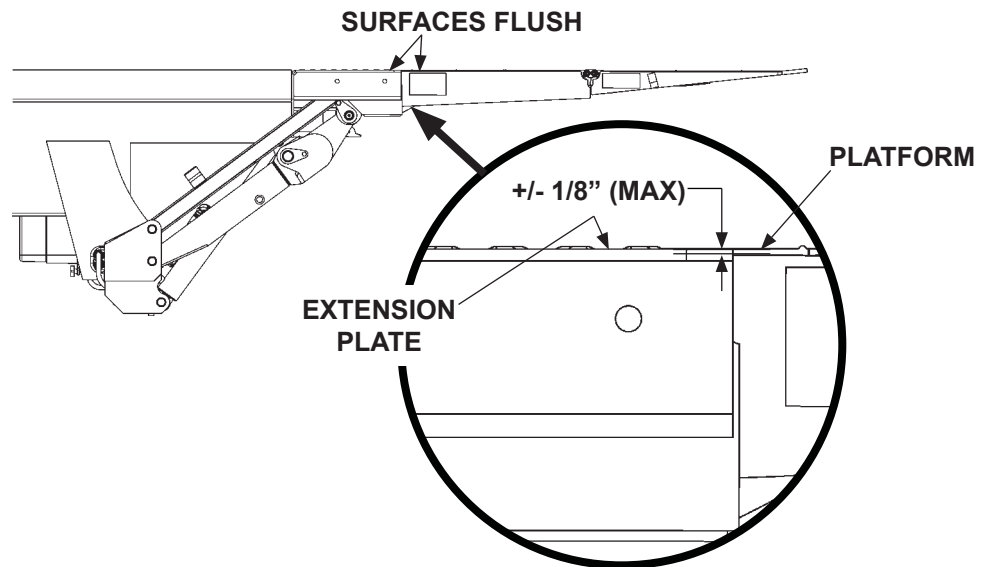

DIFFERENCE IN HEIGHT FOR TOP OF PLATFORM & EXTENSION PLATE (LH VIEW)
FIG. 47-2

STEP 11 - INSTALL OPENER & LICENSE PLATE BRACKET WITH ICC BUMPER OR UNDERRIDE

NOTE: If Liftgate is equipped with underride, skip these instructions for installation with ICC bumper. Go to the instructions for **INSTALLATION WITH UNDERRIDE**.

INSTALLATION WITH ICC BUMPER

1. Lower platform to ground level (**FIG. 48-1**). Refer to operating instructions in **Operation Manual**.

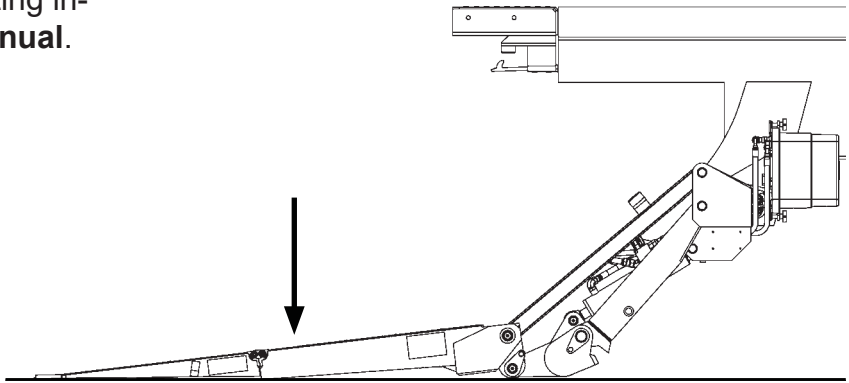

LOWERING PLATFORM
FIG. 48-1

⚠ WARNING

To prevent accidental personal injury and equipment damage, disconnect (-) battery cable and (+) cable from battery.

2. Disconnect power to the pump by disconnecting negative (-) and positive (+) cables from battery (**FIG. 48-2**). Reinstall nuts on negative (-) and positive (+) battery terminals.

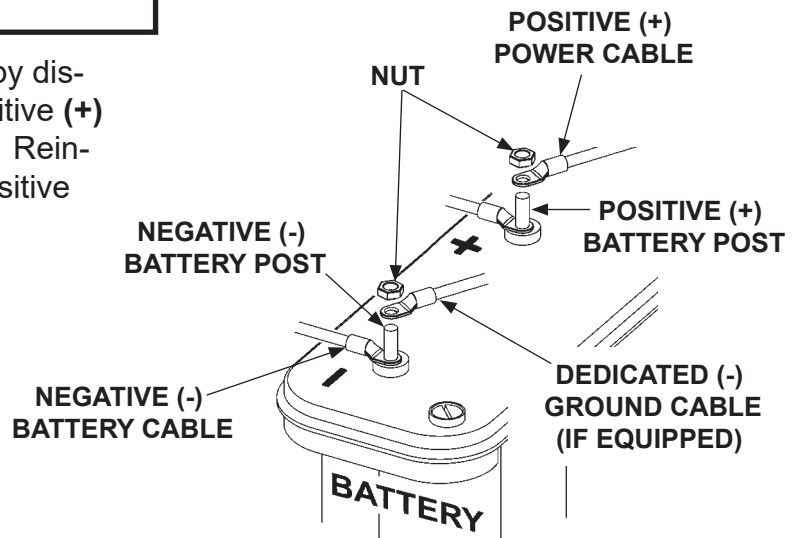

DISCONNECTING BATTERY POWER
FIG. 48-2

STEP 11 - INSTALL OPENER & LICENSE PLATE BRACKET WITH ICC BUMPER OR UNDERRIDE - Cont'd

NOTE: License plate bracket can be bolted in 4 positions on the ICC bumper brackets. License plate bracket can be bolted on the inside or outside of the LH bumper bracket or RH bumper bracket.

3. Bolt ICC bumper, opener (parts bag items), and license plate bracket to main frame as shown in **FIG. 49-1**. Then, torque bolts and lock nuts to **40 lb-ft.**

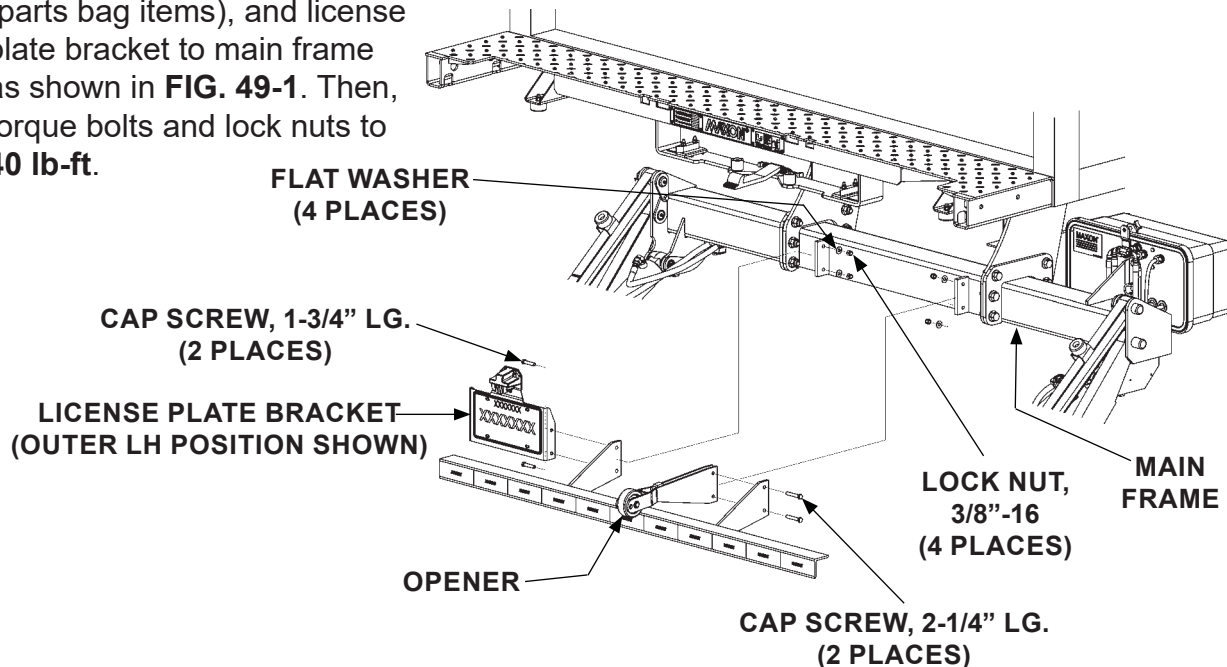

**BOLTING ON ICC BUMPER, OPENER & LICENSE PLATE BRACKET
FIG. 49-1**

4. Reconnect negative (-) battery cable to negative (-) battery terminal (**FIG. 49-2**). If dedicated ground cable was installed, connect ground (-) cable to negative (-) battery terminal (**FIG. 49-2**). Then, reinstall nut on negative (-) battery terminal (**FIG. 49-2**).

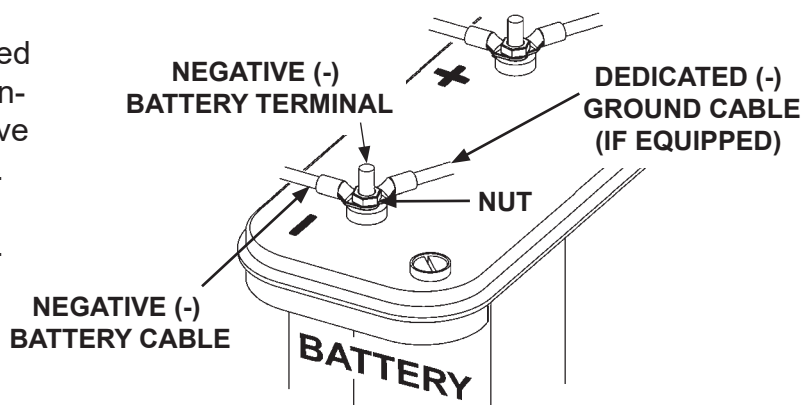

**BATTERY POWER RECONNECTED
FIG. 49-2**

5. Stow and unfold Liftgate several times to verify there is no interference. Refer to operating instructions in **Operation Manual**.

MAXON® 11921 Slauson Ave. Santa Fe Springs, CA. 90670 (800) 227-4116 FAX (888) 771-7713

STEP 11 - INSTALL OPENER & LICENSE PLATE BRACKET WITH ICC BUMPER OR UNDERRIDE - Cont'd

INSTALLATION WITH UNDERRIDE

1. Lower platform to ground level. Refer to operating instructions in **Operation Manual**.

⚠ WARNING

To prevent accidental personal injury and equipment damage, disconnect (-) battery cable and (+) cable from battery.

2. Disconnect power to the pump by disconnecting negative (-) and positive (+) cables from battery (**FIG. 50-1**). Reinstall nuts on negative (-) and positive (+) battery terminals.

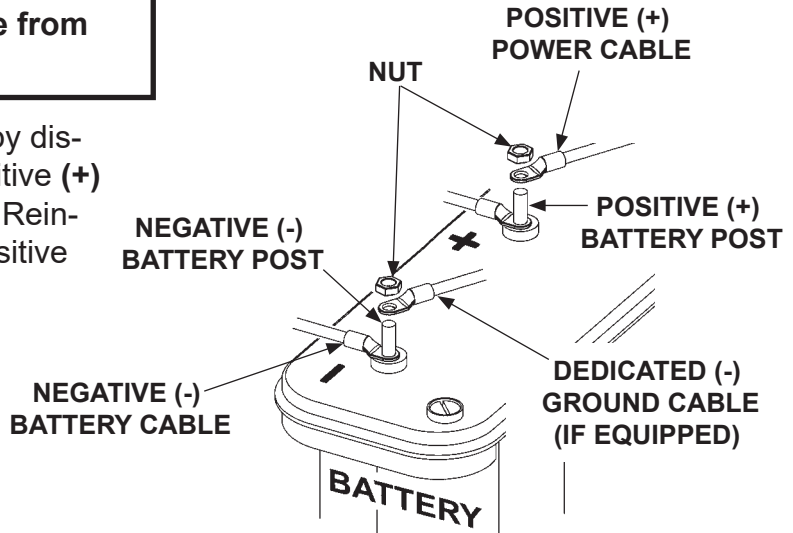

**DISCONNECTING BATTERY POWER
FIG. 50-1**

3. Bolt opener and license plate bracket to main frame as shown in **FIG. 50-2**. Then, torque bolts and lock nuts to **40 lb-ft.**

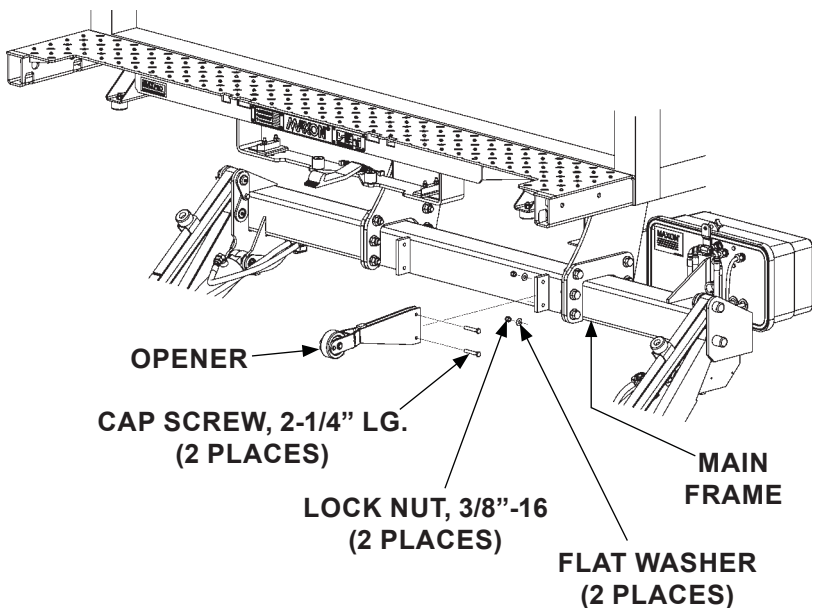

**BOLTING ON OPENER & LICENSE
PLATE BRACKET
FIG. 50-2**

STEP 11 - INSTALL OPENER & LICENSE PLATE BRACKET WITH ICC BUMPER OR UNDERRIDE - Cont'd

INSTALLATION WITH UNDERRIDE - Continued

4. Reconnect negative (-) battery cable to negative (-) battery terminal (FIG. 51-1). If dedicated ground cable was installed, connect ground (-) cable to negative (-) battery terminal (FIG. 51-1). Then, reinstall nut on negative (-) battery terminal (FIG. 51-1).

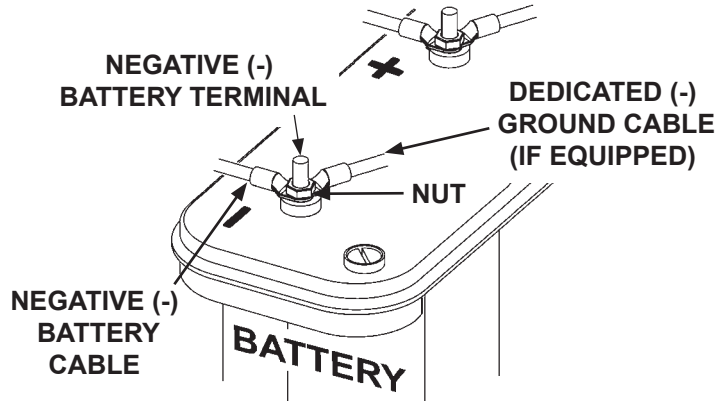

**BATTERY POWER RECONNECTED
FIG. 51-1**

NOTE: Ensure license plate bracket is vertical with platform and underride in the stowed position.

5. Stow platform (FIG. 51-2). Refer to operating instructions in Operation Manual.
6. Put license plate bracket in desired position on top of underride (FIG. 51-2). Next, use bottom flange of license plate bracket to mark the two holes on top of underride. Then, drill the 2 holes with 1/4" drill bit (FIG. 51-2).

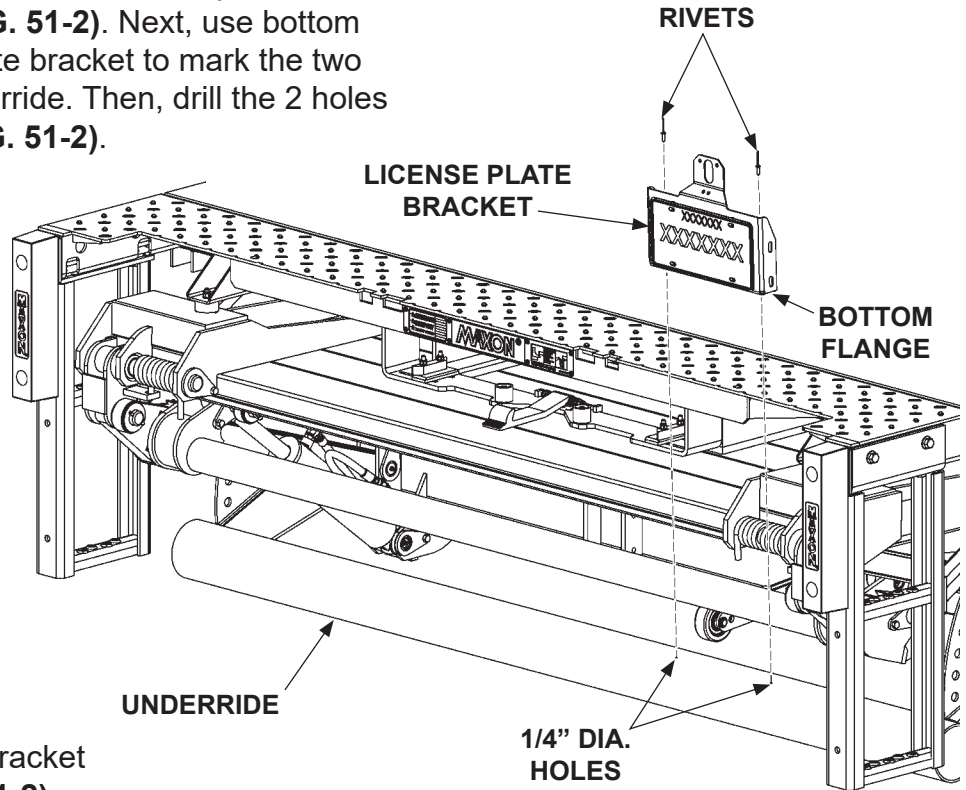

**EXAMPLE FOR POSITIONING & RIVETING
LICENSE PLATE BRACKET TO UNDERRIDE
FIG. 51-2**

7. Rivet license plate bracket to underride (FIG. 51-2).
8. Stow and unfold platform several times to verify there is no interference.

STEP 12 - ADJUST PLATFORM (IF REQUIRED)

NOTE: Before doing the following procedure, make sure vehicle is parked on level ground.

- Lower platform to the ground. With the platform and flipover unfolded, raise platform to bed level (**FIG. 52-1**). Measure how much the outboard edge of platform rises above bed level (**FIG. 52-1**). The outboard edge must be level or a maximum of 1" above bed level (**FIG. 52-1**). If indication is correct, Liftgate is installed correctly and no adjustment is needed. If the outboard edge is below bed level, do instructions **2, 3, and 6**. If outboard edge is higher than 1", do instructions **4 through 6**.

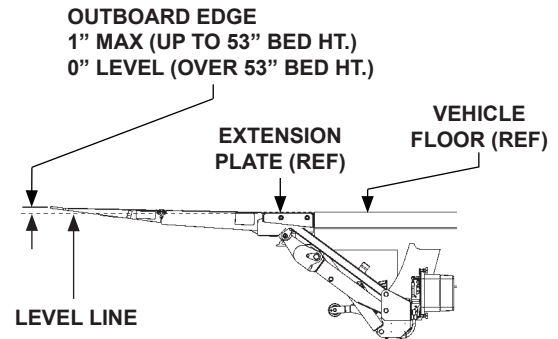

PLATFORM EDGE AT OR ABOVE BED LEVEL
FIG. 52-1

- Compare measurement "A" (**FIG. 52-2**) with the distances and shims (in **TABLE 52-1**). For example: If measurement "A" (**FIG. 52-2**) is 1" below level and you want to raise outboard edge of platform 1" above level, use 1/8" shim to raise 2" (**TABLE 52-1**).

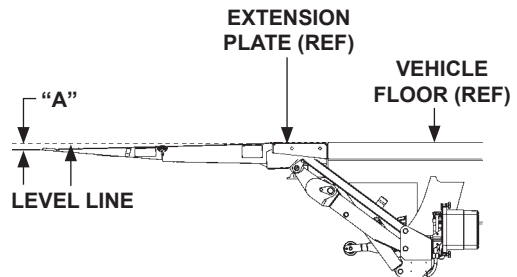

PLATFORM EDGE BELOW BED LEVEL
FIG. 52-2

RAISE PLATFORM EDGE (OUTBOARD) THIS DISTANCE ("A")	REQUIRED SHIM THICKNESS	WELD SIZE "W"
1"	1/16"	1/16"
2"	1/8"	1/8"
3"	3/16"	3/16"
4"	1/4"	1/4"

TABLE 52-1

NOTE: If you need a 3/16" shim for this adjustment, use a 1/8" shim and 1/16" shim together on each platform stop.

- Weld shims (Parts Box B) on both platform stops (**FIG. 52-3**) to raise outboard edge of platform to correct position.

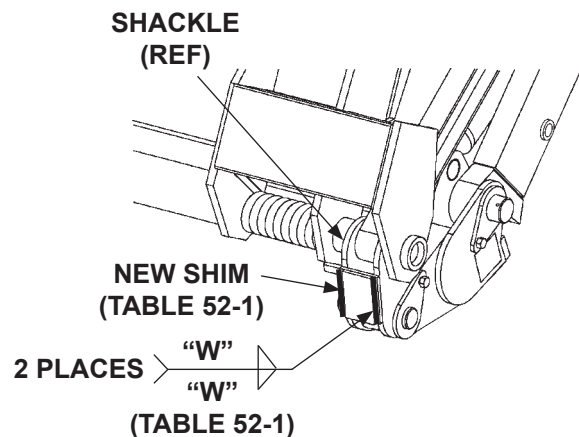

WELDING SHIMS (CURBSIDE SHOWN)
FIG. 52-3

STEP 12 - ADJUST PLATFORM - Continued

4. Compare measurement "B" (FIG. 53-1) with the distances and grinding depths in TABLE 53-1. For example: If measurement "B" (FIG. 53-1) is 3" above bed level and you want to lower the outboard edge of platform to 1" above bed level, grind 1/8" from each platform stop (TABLE 53-1).

LOWER PLATFORM EDGE (OUTBOARD) THIS DISTANCE ("B")	GRIND METAL FROM PLATFORM STOP
1"	1/16"
2"	1/8"
3"	3/16"
4"	1/4"

TABLE 53-1

5. Grind metal from platform stops (FIG. 53-2) to lower outboard edge of platform to correct position.

6. Lower the platform, then raise it to bed level. The outboard edge of platform should be level or up to 1" maximum above bed level (FIG. 53-3).

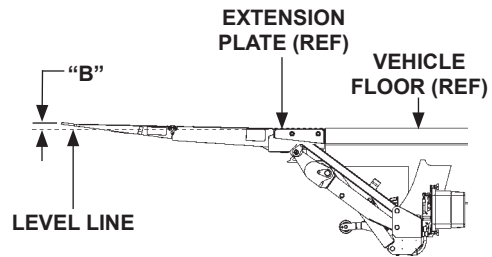

PLATFORM EDGE ABOVE BED LEVEL
FIG. 53-1

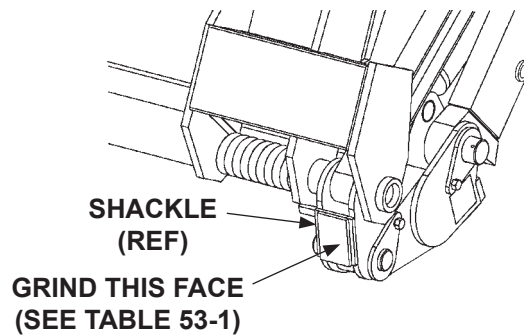

GRINDING PLATFORM STOPS
(CURBSIDE SHOWN)
FIG. 53-2

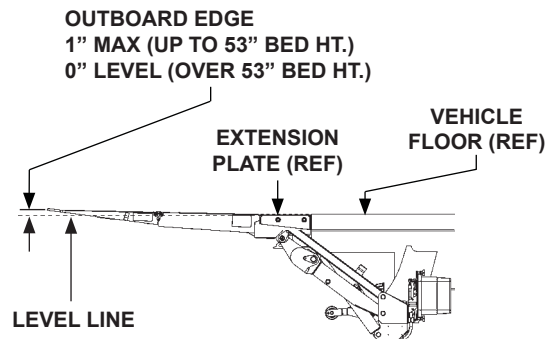

PLATFORM EDGE ABOVE BED LEVEL
FIG. 53-3

STEP 13 - FINISH WELDING LIFTGATE TO VEHICLE

CAUTION

Prevent damage to hydraulic hoses. Before welding next to hydraulic hoses, protect the hoses with a heat-resistant cover such as a welding blanket.

CAUTION

To protect the original paint system, a 3" wide area of paint must be removed from all sides of the weld area before welding.

CAUTION

When using an electric welder, connect the welder ground to one of the parts being welded, as close to the weld as possible. Failure to comply could result in damage to cylinders and electrical parts.

1. Weld each of the two mounting plates to vehicle frame (FIG. 54-1A).

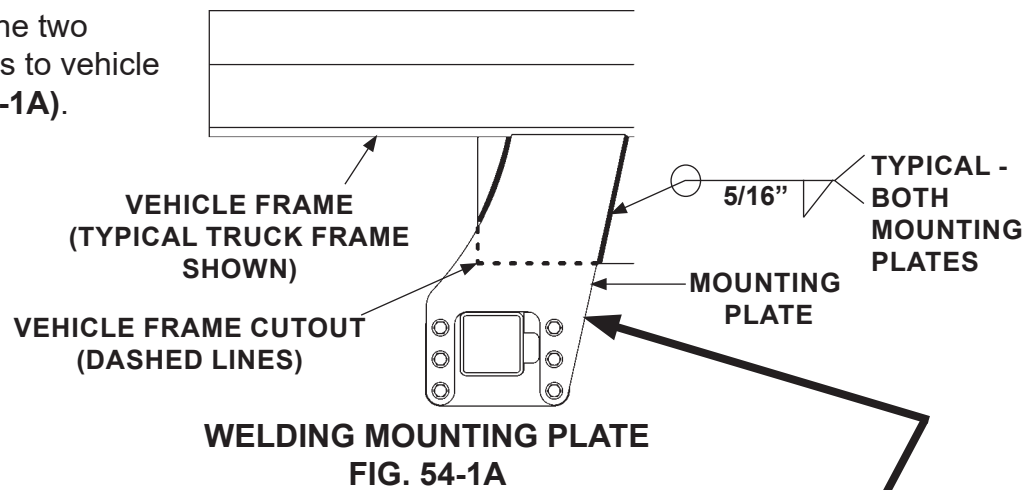

2. After welding is done and mounting plates are cool, remove and discard the 4 fiberglass sleeves shown in FIG. 54-1B. Keep the split looms to protect the hoses.

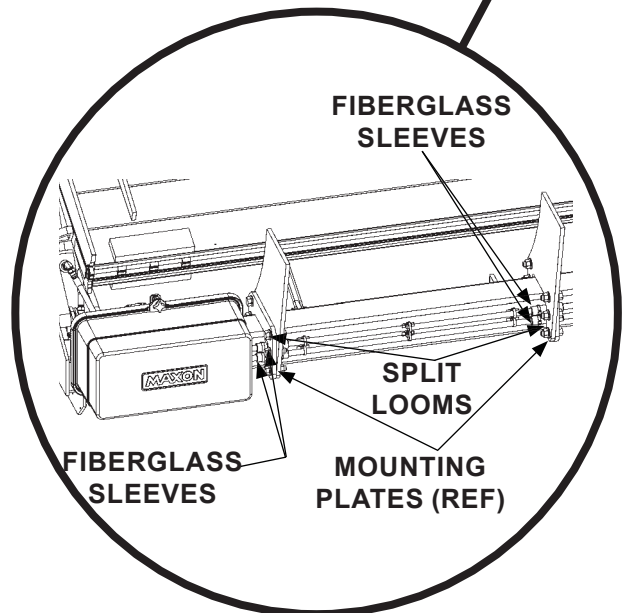
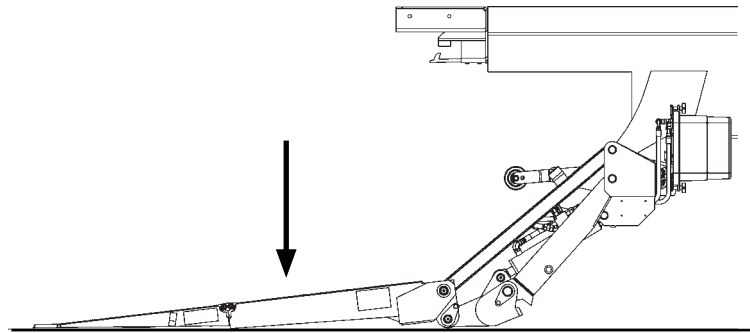

FIG. 54-1B

STEP 14 - BOLT STEPS TO EXTENSION PLATE

1. Lower platform to the ground
(FIG. 55-1).



PLATFORM LOWERED TO GROUND
FIG. 55-1

⚠ WARNING

To prevent accidental personal injury and equipment damage, disconnect (-) battery cable and (+) cable from battery.

2. Disconnect power to the pump by disconnecting negative (-) and positive (+) cables from battery (FIG. 55-2). Reinstall nuts on negative (-) and positive (+) battery terminals.

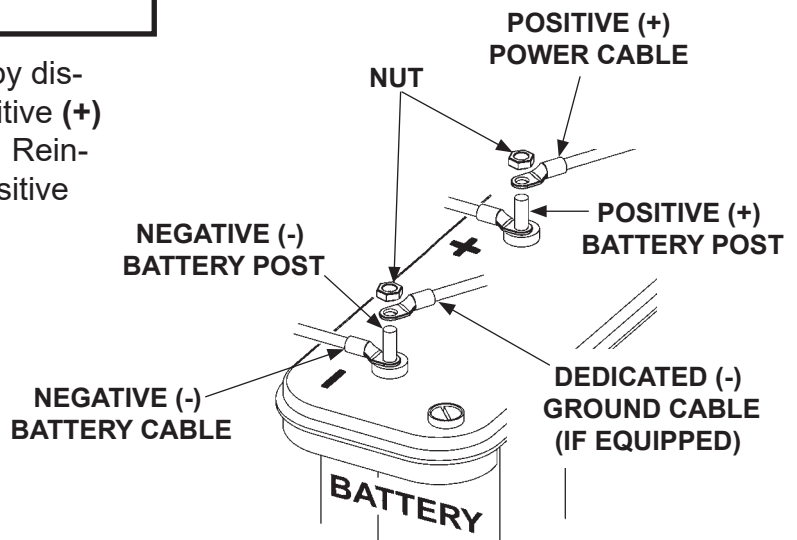

DISCONNECTING BATTERY POWER
FIG. 55-2

STEP 14- BOLT STEPS TO EXTENSION PLATE - Continued

CAUTION

To prevent interference with Liftgate and possible damage, maintain 90° angle between steps and extension plate. Tighten bolts only in the order shown in illustration.

NOTE: If 102" extension kit is to be installed for 102" wide vehicle, install the extension kit before installing the steps.

3. Line up the LH step (Kit item) on LH side of the extension plate. Bolt step to extension plate (**FIG. 56-1**). Tighten bolts **1, 2, 3** and **4** in the numbered order shown in **FIG. 56-1**. Then, torque each bolt and lock nut to **105 lb-ft.** in the same order.

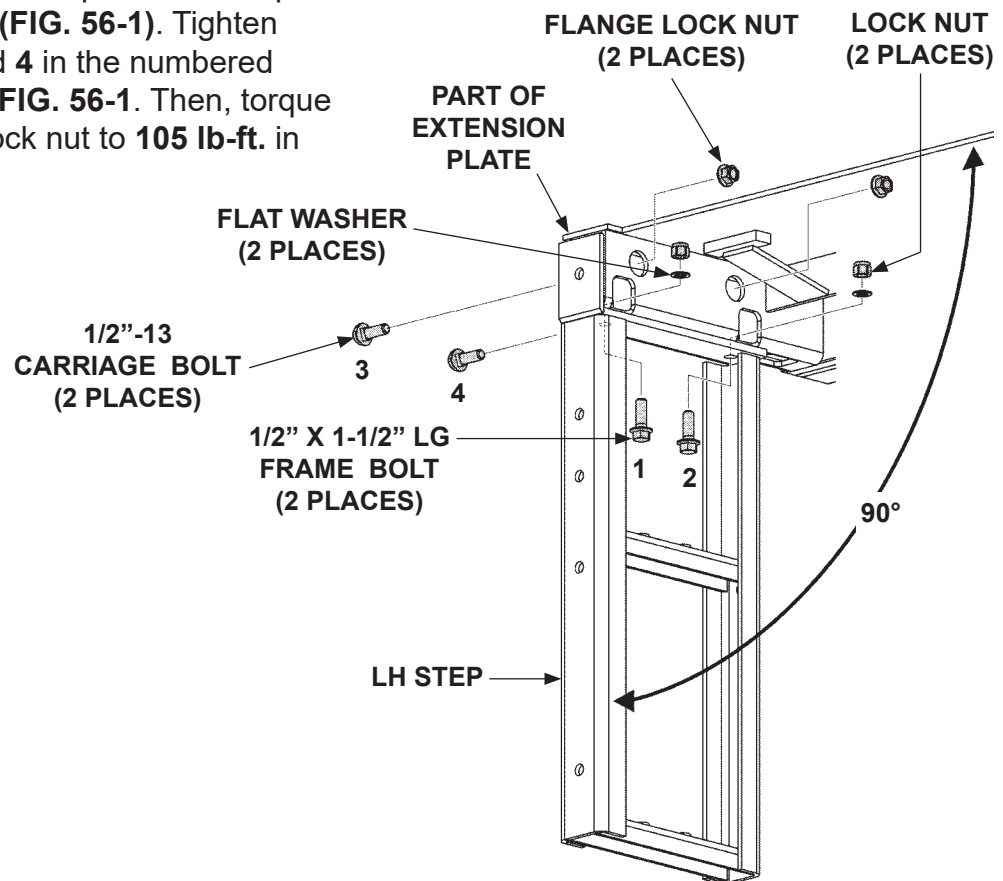

**BOLTING STEP TO EXTENSION PLATE
(LH DUAL STEP SHOWN)
FIG. 56-1**

STEP 14 - BOLT STEPS TO EXTENSION PLATE - Continued

4. Bolt the support (Kit item) to mounting channel (Kit item) (FIG. 57-1).

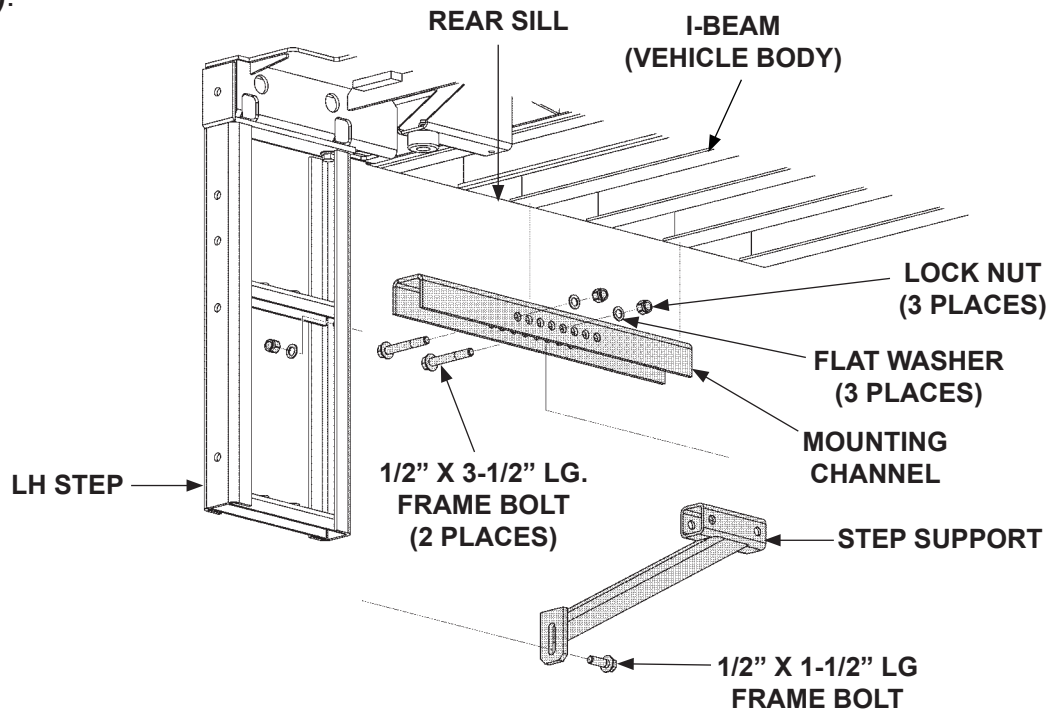

**BOLTING SUPPORT TO MOUNTING CHANNEL &
STEP (LH STEP & SUPPORT SHOWN)
FIG. 57-1**

5. Butt the flat part of the mounting channel against bottom of vehicle rear sill and I-beams. Then, butt the support against back of the step (FIG. 57-1).
6. Ensure slotted hole in the step support is lined up with the hole on the step (FIG. 57-1). Then, bolt the support to step (FIG. 57-1). Torque the lock nuts (FIG. 57-1) to 105 lb-ft.

STEP 14 - BOLT STEPS TO EXTENSION PLATE - Cont'd

NOTE: Before welding mounting channel to vehicle body, ensure step is straight and steps are in vertical position.

7. Weld the flat part of the mounting channel to vehicle body as shown in **FIG. 58-1**.

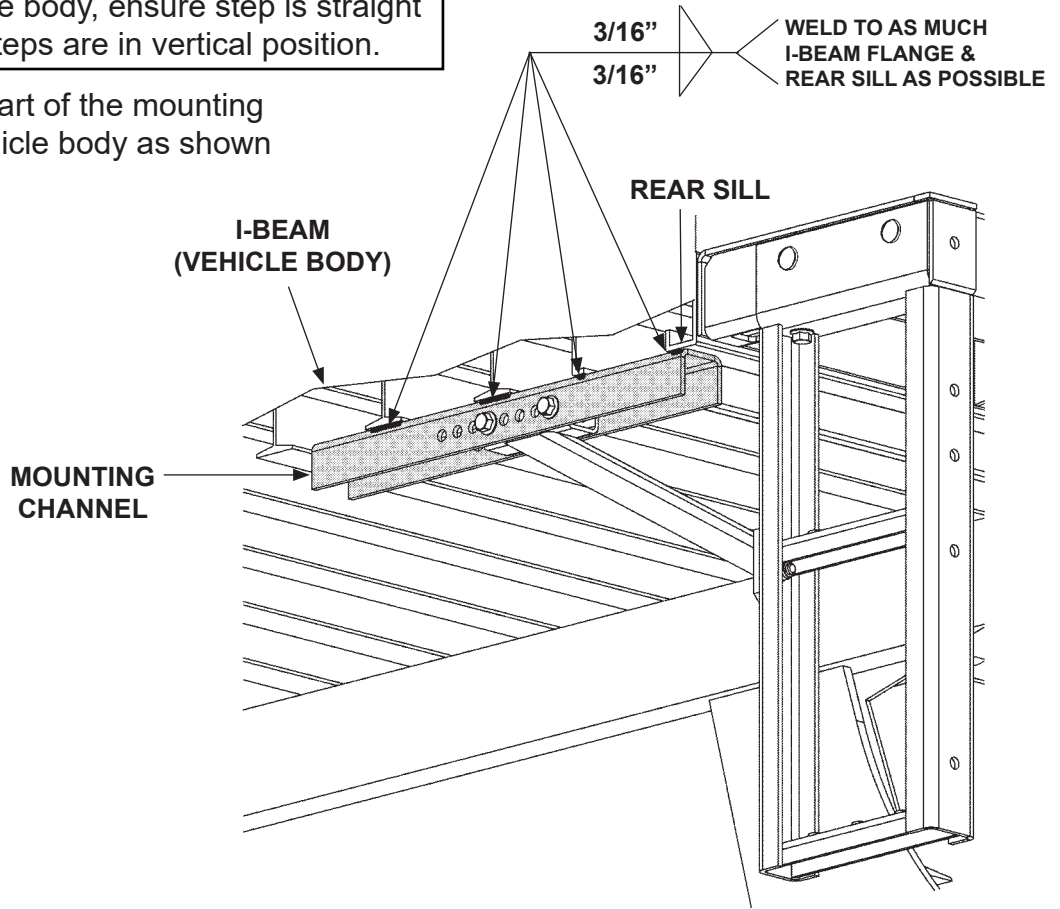

**WELDING FLAT OF MOUNTING CHANNEL TO VEHICLE BODY (LH DUAL STEP SHOWN)
FIG. 58-1**

- 8. Repeat instructions **3 through 7** for RH step. Use the RH Step Assembly (Kit item).
- 9. Reconnect negative (-) battery cable to negative (-) battery terminal (**FIG. 58-2**). If dedicated ground cable was installed, connect ground (-) cable to negative (-) battery terminal (**FIG. 58-2**). Then, reinstall nut on negative (-) battery terminal (**FIG. 58-2**).

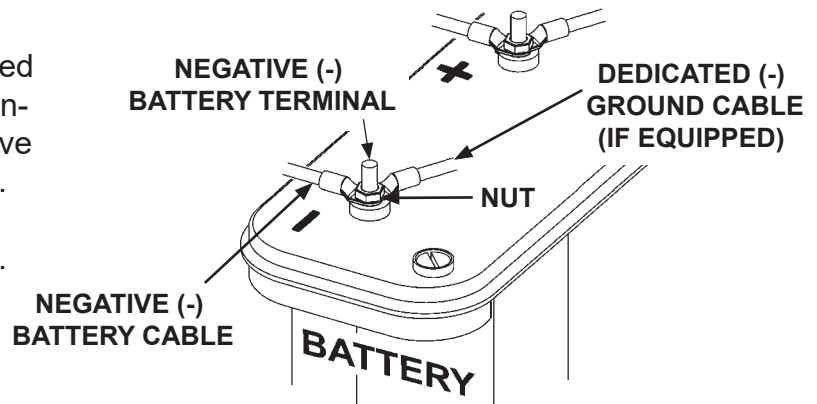

**BATTERY POWER RECONNECTED
FIG. 58-2**

STEP 15 - ADJUST WALK RAMP PADS

1. Stow the platform (FIG. 59-1).

NOTE: If necessary to lower each walk ramp pad, the steel shim under each pad can be removed.

2. Loosen the socket head screws and lock nuts (FIG. 59-1A). Slide the pads toward the outside of the walk ramp box (FIG. 59-1A).

NOTE: If a different ramp stop method or equipment is required, the ramp stops shown in the illustration can be removed.

3. Install the walk ramp (not shown) according to manufacturer's instructions.

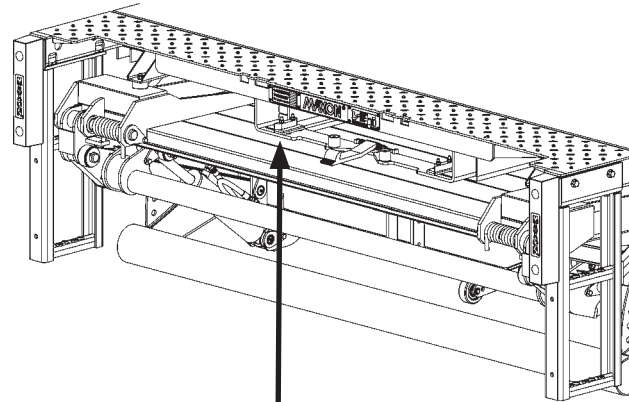

LIFTGATE WITH
PLATFORM STOWED
FIG. 59-1

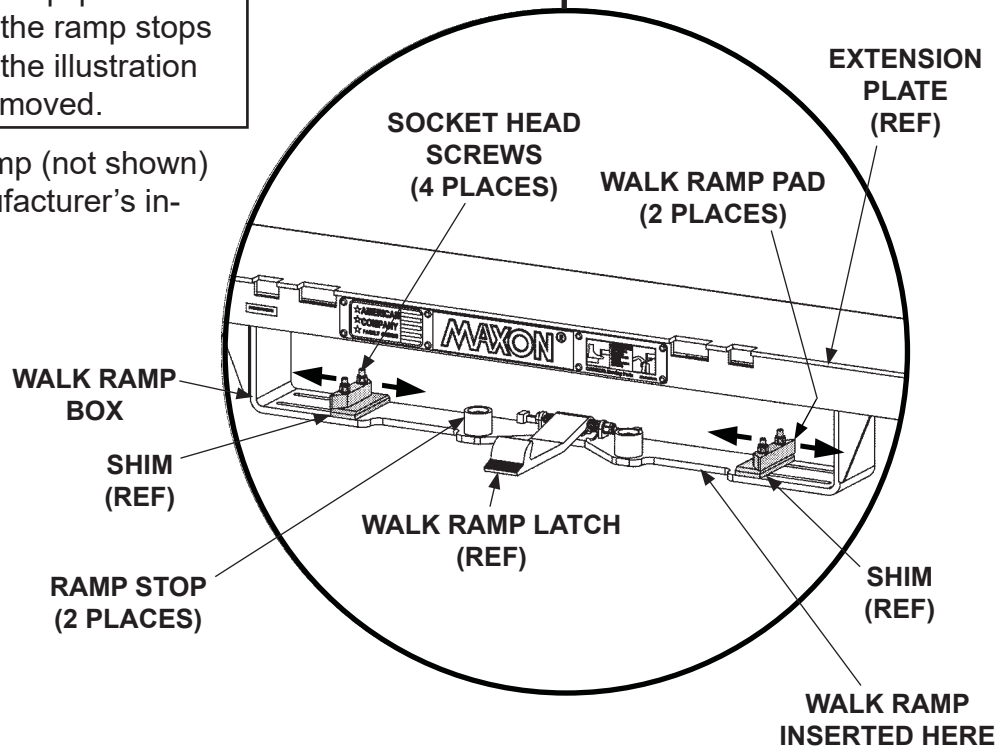

ADJUSTING WALK RAMP PADS
FIG. 59-1A

4. Slide the ramp pads to the edge of the walk ramp (not shown) (FIG. 59-1A).
5. Tighten the socket head screws and lock nuts securely (FIG. 59-1A).

STEP 16 - VEHICLE TAILLIGHT POSITIONING

NOTE: Taillights may interfere with Liftgate. Taillights and attaching hardware are not provided with the Liftgate. If needed, install vehicle taillights to comply with state and federal vehicle lighting requirements, such as FMVSS 108.

STEP 17 - LUBE GREASE FITTINGS AS NEEDED

NOTE: Lube fittings are shown for the RH cylinder, lift arm, and parallel arm. There are also lube fittings at the same places on the LH cylinder, lift arm, and parallel arm.

Refer to lubrication diagram (**FIG. 61-1**) to find the lube fittings on cylinders and arms. Pump EP chassis grease in each lube fitting on the cylinders and arms until grease starts oozing from ends of the bearings. Then, wipe off excess grease with a clean lint-free cloth.

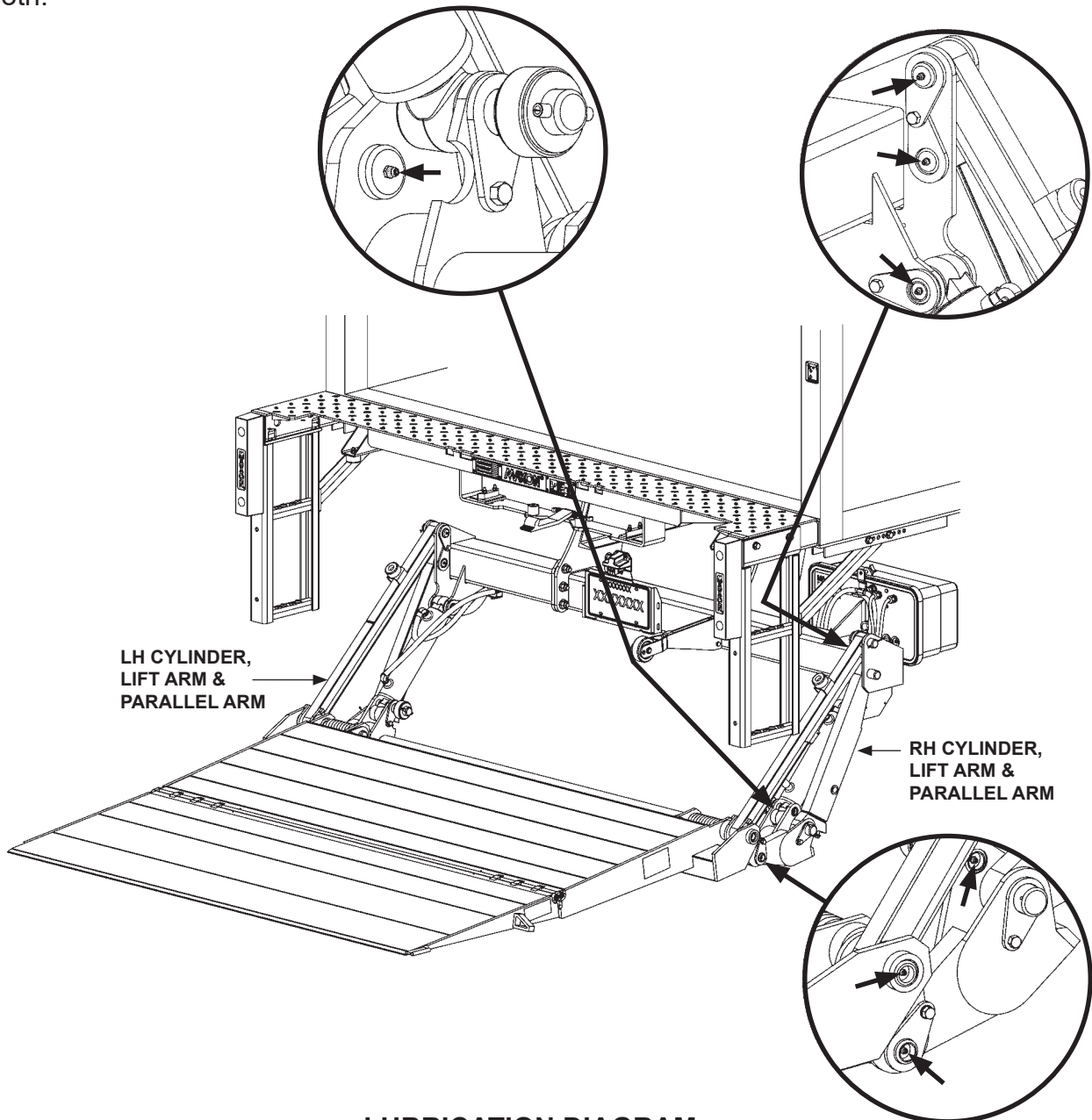

**LUBRICATION DIAGRAM
FIG. 61-1**

APPLY DECALS

NOTE: Ensure there is no residue, dirt or corrosion where decals are attached. If necessary, clean surface before attaching decals.

NOTE: Preferred decal layout is shown. Decals on the Liftgate are attached at the factory. If vehicle does not permit this layout, decals in the manual and decal kit must be applied so that they are easily visible when approaching vehicle to operate Liftgate. Use good common sense when locating these decals on vehicle.

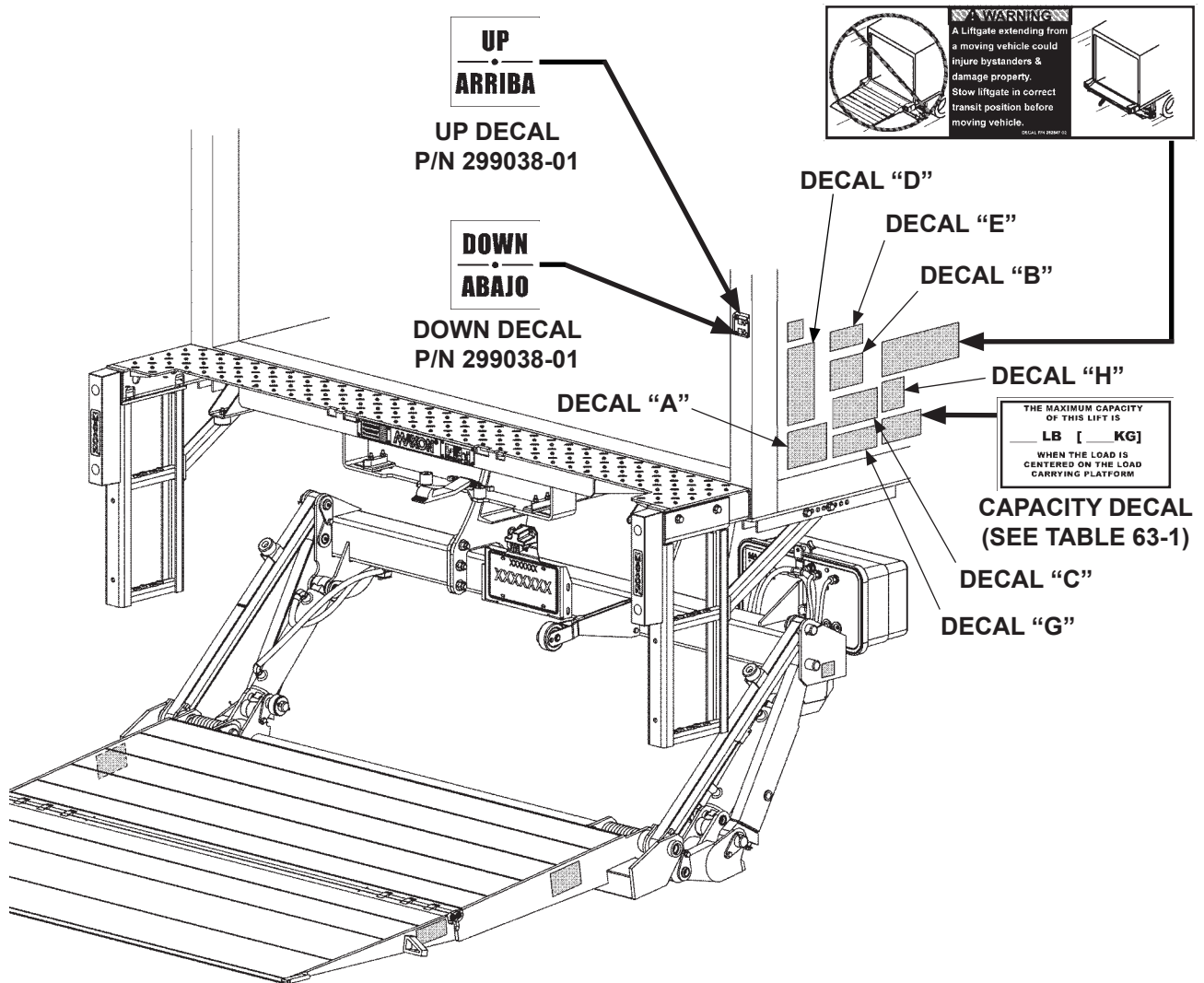

FIG. 62-1

APPLY DECALS - Continued

SAFETY INSTRUCTIONS

Read all decals and operation manual before operating liftgate.

- Do not use liftgate unless you have been properly instructed and have read, and are familiar with, the operating instructions.
- Be certain vehicle is properly and securely braked before using the liftgate.
- Always inspect this liftgate for maintenance or damage before using it. Do not use liftgate if it shows any sign of damage or improper maintenance.
- Do not overload.
- Make certain the area in which the platform will open and close is clear before opening or closing the platform.
- Make certain platform area, including the area in which loads may fall from platform, is clear before and at all times during operation of liftgate.
- This liftgate is intended for loading and unloading of cargo only. Do not use this liftgate for anything but its intended use.

(A)

SAFETY INSTRUCTIONS

- Read **WARNING** decal for the walk ramp before you set up walk ramp & stow walk ramp.
- To set up walk ramp & stow walk ramp, refer to walk ramp manufacturer's instructions.

(G)

WARNING

Read this information carefully.

- Improper operation of this Liftgate can result in serious personal injury. If you do not have a copy of the operating instructions, please obtain them from your employer, distributor, or lessor before you attempt to operate Liftgate.
- If there are signs of improper maintenance, damage to vital parts, or slippery platform surface, do not use the Liftgate until these problems have been corrected.
- If you are using a pallet jack, be sure it can be maneuvered safely.
- Do not operate a forklift on the platform.
- Do not allow any part of yours or your helper's body to be placed under, within, or around any portion of the moving Liftgate, or its mechanisms, or in a position that would trap them between the platform and the ground or truck when the Liftgate is operated.
- If a helper is riding the platform with you, make sure you are both doing so safely and that you are not in danger of coming in contact with any moving or potentially moving obstacles.
- USE GOOD COMMON SENSE.**
- If load appears to be unsafe, do not lift or lower it.

For a free copy of other manuals that pertain to this model Liftgate, please visit our website at www.maxonlift.com or call Customer Service at (800) 227-4116.

(B)

WARNING

Liftgate hazards can result in crushing or falling.

Keep hands and feet clear of pinch points.

If riding liftgate, make sure load is stable and footing is solid.



Read and understand all instructions and WARNINGS before use.

(C)

OPERATING INSTRUCTIONS

GPTWR

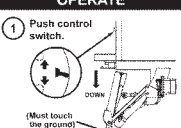
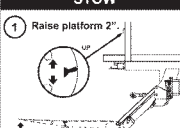
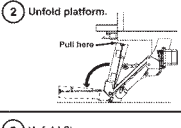
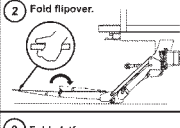
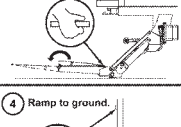
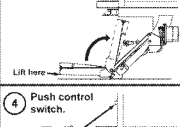
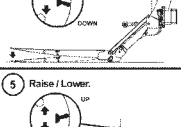
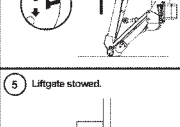
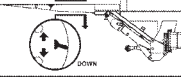
Scan this QR code to see operation video.

OPERATE	STOW
<p>1 Push control switch.</p> 	<p>1 Raise platform 2".</p> 
<p>2 Unfold platform.</p> 	<p>2 Fold flipover.</p> 
<p>3 Unfold flipover.</p> 	<p>3 Fold platform.</p> 
<p>4 Ramp to ground.</p> 	<p>4 Push control switch.</p> 
<p>5 Raise / Lower.</p> 	<p>5 Liftgate stowed.</p> 

PIN 297207-01 (D)

CAUTION

Always stand clear of platform area.

(E)

WARNING



Never operate liftgate when walk ramp is extended.

Always stow ramp before operating liftgate.

(H)

DECAL SHEET
P/N 297207-01
FIG. 63-1

MODEL	DECAL P/N	CAPACITY DECAL
GPTWR-25	220382	2500 POUNDS
GPTWR-3	220388	3000 POUNDS
GPTWR-4	296274-01	4000 POUNDS
GPTWR-5	296274-02	5000 POUNDS

CAPACITY DECAL
TABLE 63-1

DECALS & PLATES

NOTE: Preferred decal layout is shown. Decals on the Liftgate are attached at the factory.



MAXON NAME PLATE
P/N 280004-01

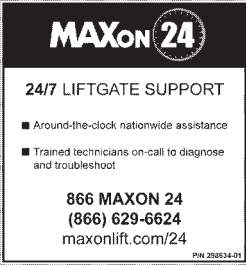

MAXON 24/7 SUPPORT DECAL
P/N 298634-01



PARTS QR CODE DECAL
P/N 299348-06

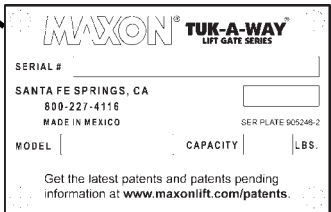

SERIAL PLATE (REF)

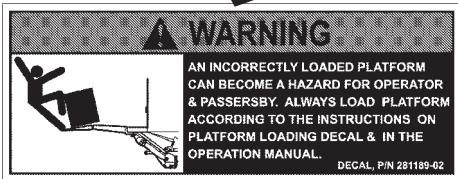

PLATFORM WARNING DECAL
P/N 281189-02
(2 PLACES)

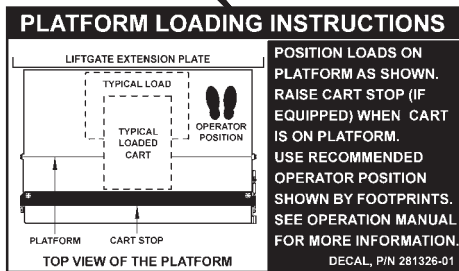

PLATFORM LOADING DECAL
P/N 281326-01
(2 PLACES)

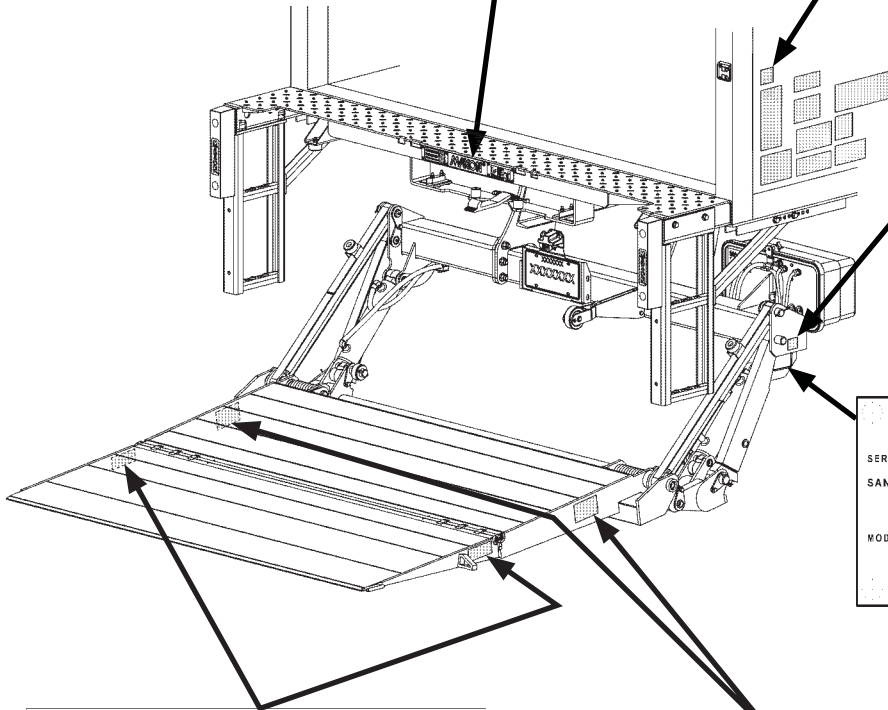

FIG. 64-1

MAXON[®] 11921 Slauson Ave. Santa Fe Springs, CA. 90670 (800) 227-4116 FAX (888) 771-7713

TOUCH-UP PAINTED OR GALVANIZED FINISH

CAUTION

Damaged cylinder seals and contaminated hydraulic fluid can result from painting the polished portion of the cylinder rod. To prevent damage, protect the exposed polished portion of the cylinder rod while painting.

- If bare metal or primer is exposed on the painted portions of the Liftgate, touch up the paint. To maintain the protection provided by the original paint system, **MAXON** recommends aluminum primer touch-up paint kit.
- If bare metal is exposed on galvanized portions of the Liftgate, touch up the galvanized finish. To maintain the protection provided by the original galvanized finish, **MAXON** recommends cold galvanize spray.

SYSTEM DIAGRAMS

PUMP MOTOR & SOLENOID SWITCH OPERATION - SINGLE PUMP

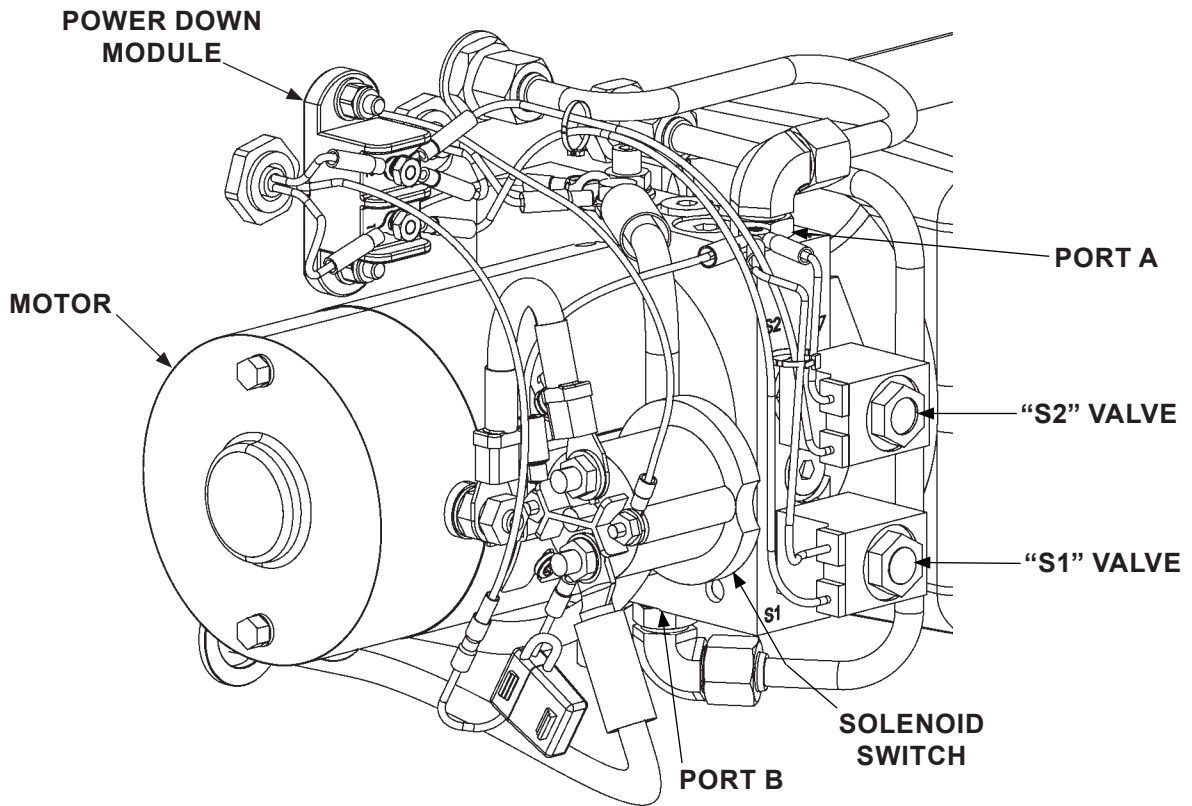

POWER UNIT

FIG. 66-1

NOTE: Hydraulic lock valve is on the RH cylinder.

PUMP MOTOR & SOLENOID SWITCH OPERATION						
LIFTGATE FUNCTION	PORT	SOLENOID SWITCH OPERATION (✓ MEANS ENERGIZED)				
		MOTOR	VALVE "S2"	VALVE "S1"	LOCK VALVE	POWER DOWN MODULE
RAISE	A	✓	-	✓	-	-
LOWER	B	✓	✓	-	✓	✓

REFER TO VALVES SHOWN ON HYDRAULIC SCHEMATIC

TABLE 66-1

PUMP MOTOR & SOLENOID SWITCH OPERATION - DUAL PUMPS

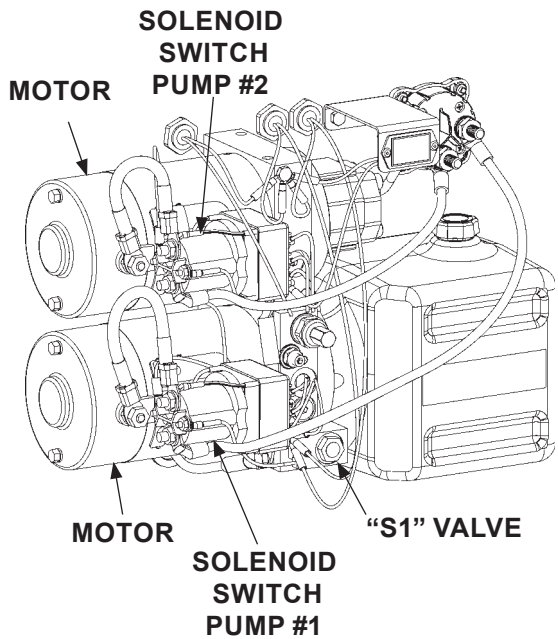

**DUAL PUMP POWER UNIT
FIG. 67-1**

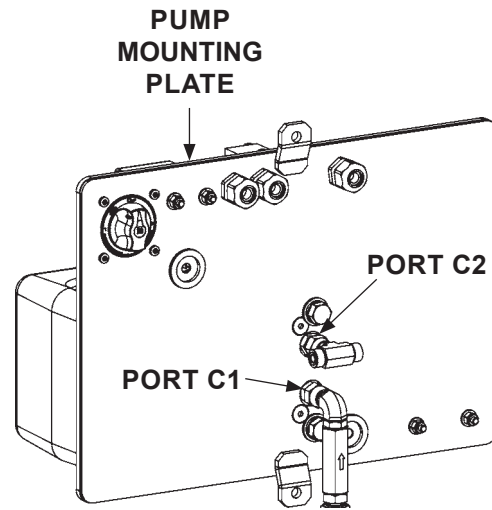

**DUAL PUMP POWER UNIT - REAR VIEW
FIG. 67-2**

NOTE: Hydraulic lock valves are located on the RH & LH cylinders.

PUMP MOTOR & SOLENOID SWITCH OPERATION					
LIFTGATE FUNCTION	PORT	SOLENOID SWITCH OPERATION (✓ MEANS ENERGIZED)			
		MOTOR	VALVE "S1"	LOCK VALVES	ARC SUPPRESSION MODULE
RAISE	C1	✓	-	-	✓
LOWER	C2	✓	✓	✓	✓
REFER TO VALVES SHOWN ON HYDRAULIC SCHEMATIC					

TABLE 67-1

HYDRAULIC SCHEMATIC (POWER DOWN)

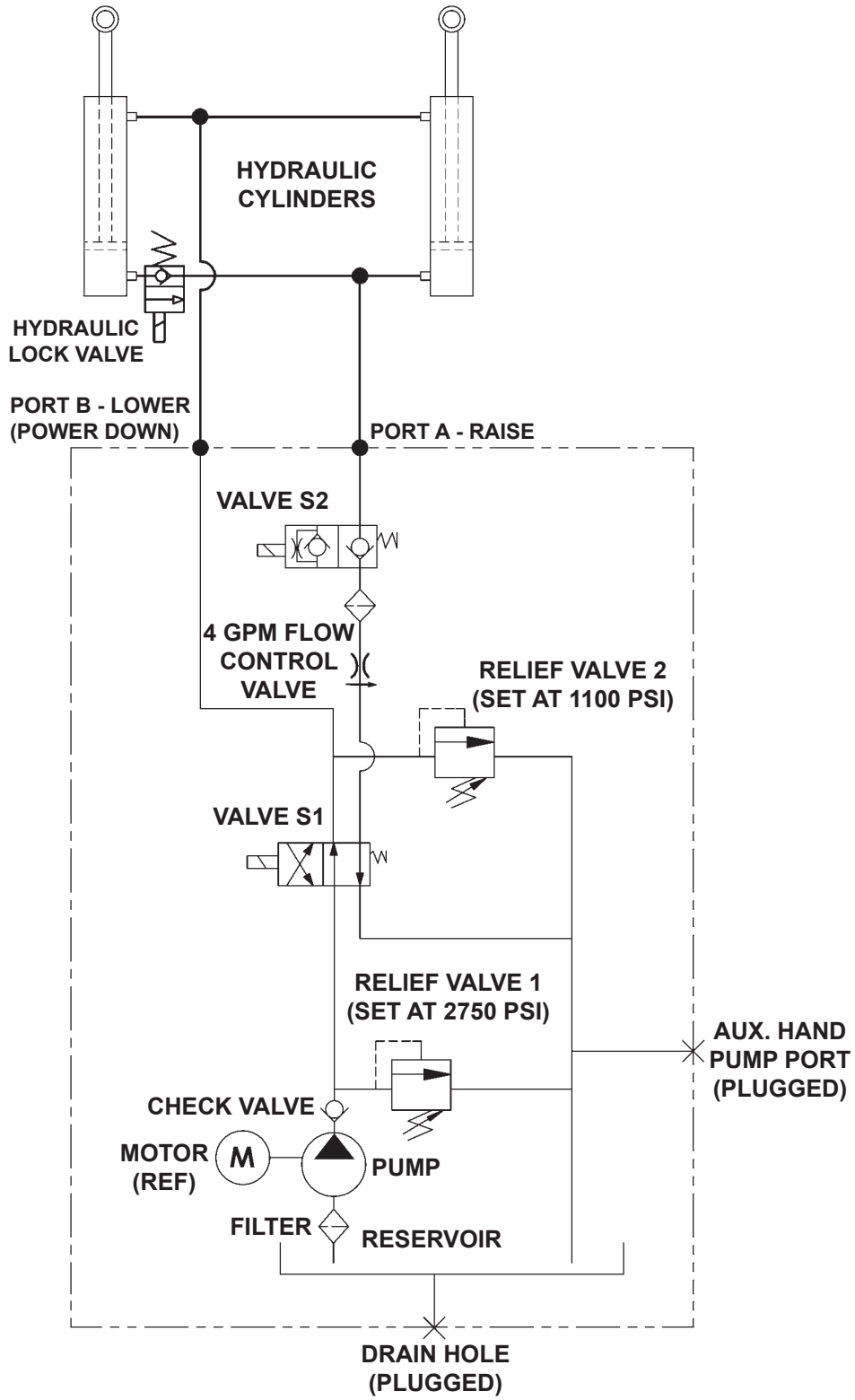

FIG. 68-1

HYDRAULIC SCHEMATIC (POWER DOWN) - DUAL PUMPS

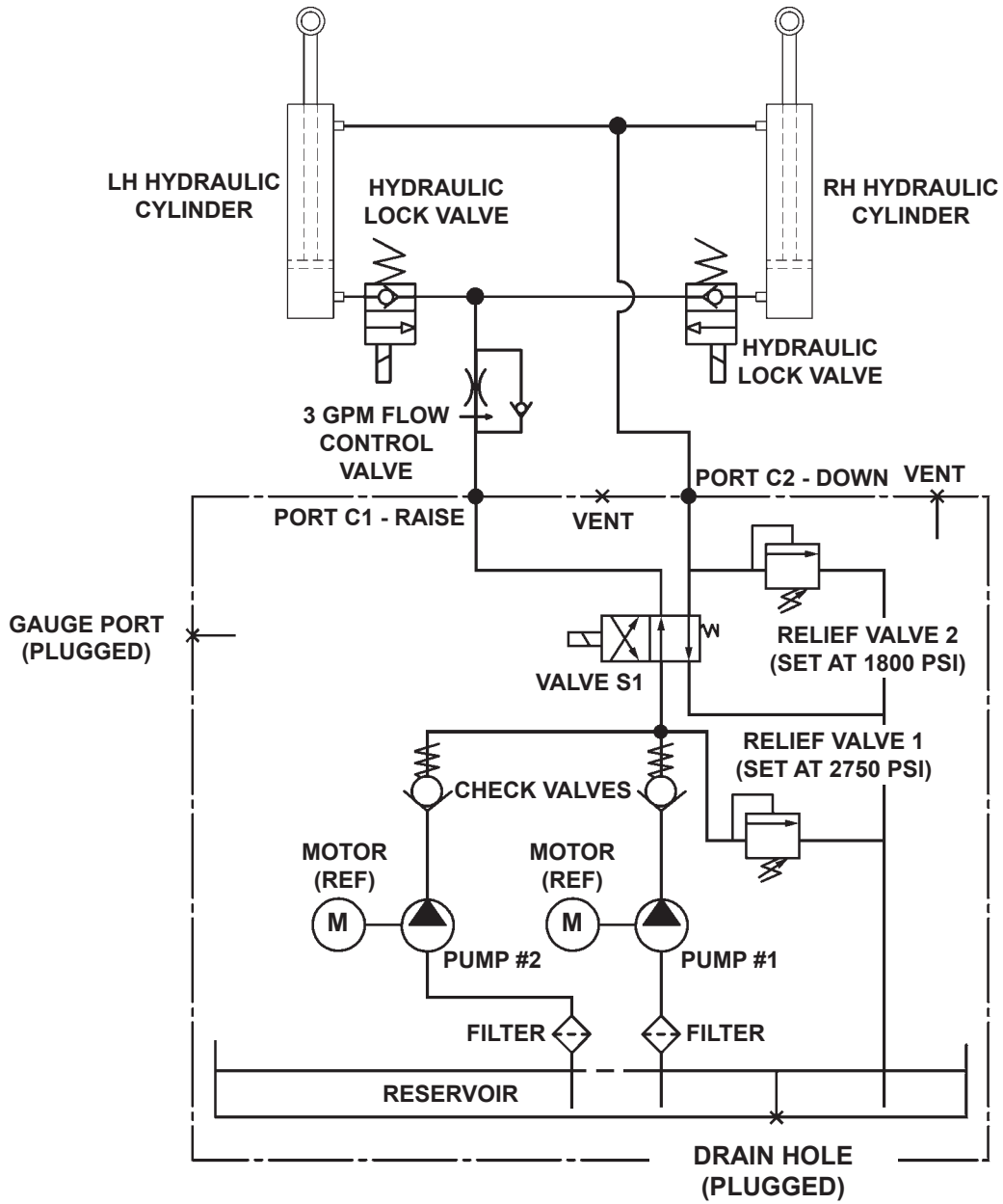

FIG. 69-1

ELECTRICAL SCHEMATIC (POWER DOWN)

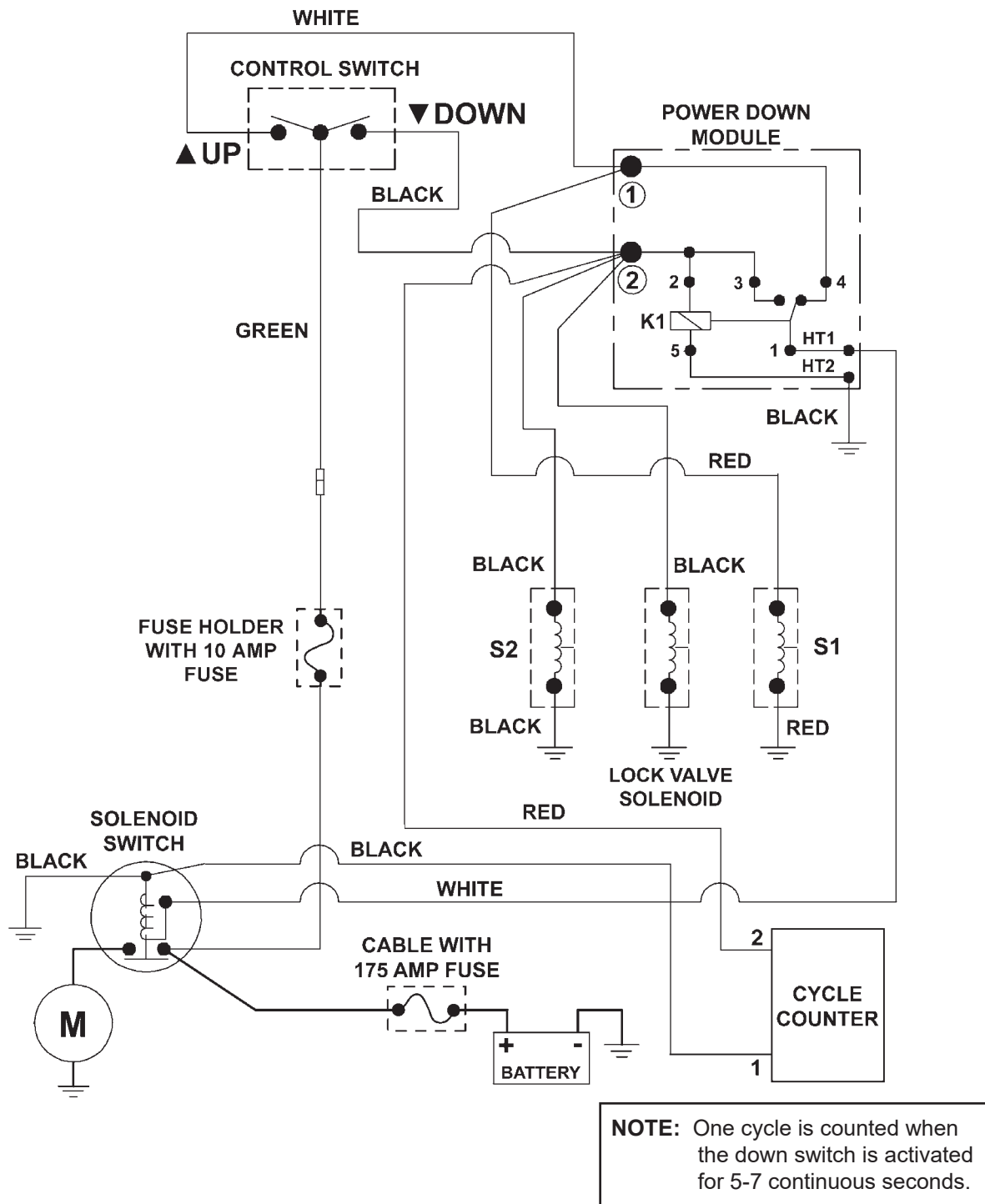

FIG. 70-1

ELECTRICAL SCHEMATIC (POWER DOWN) - DUAL PUMPS

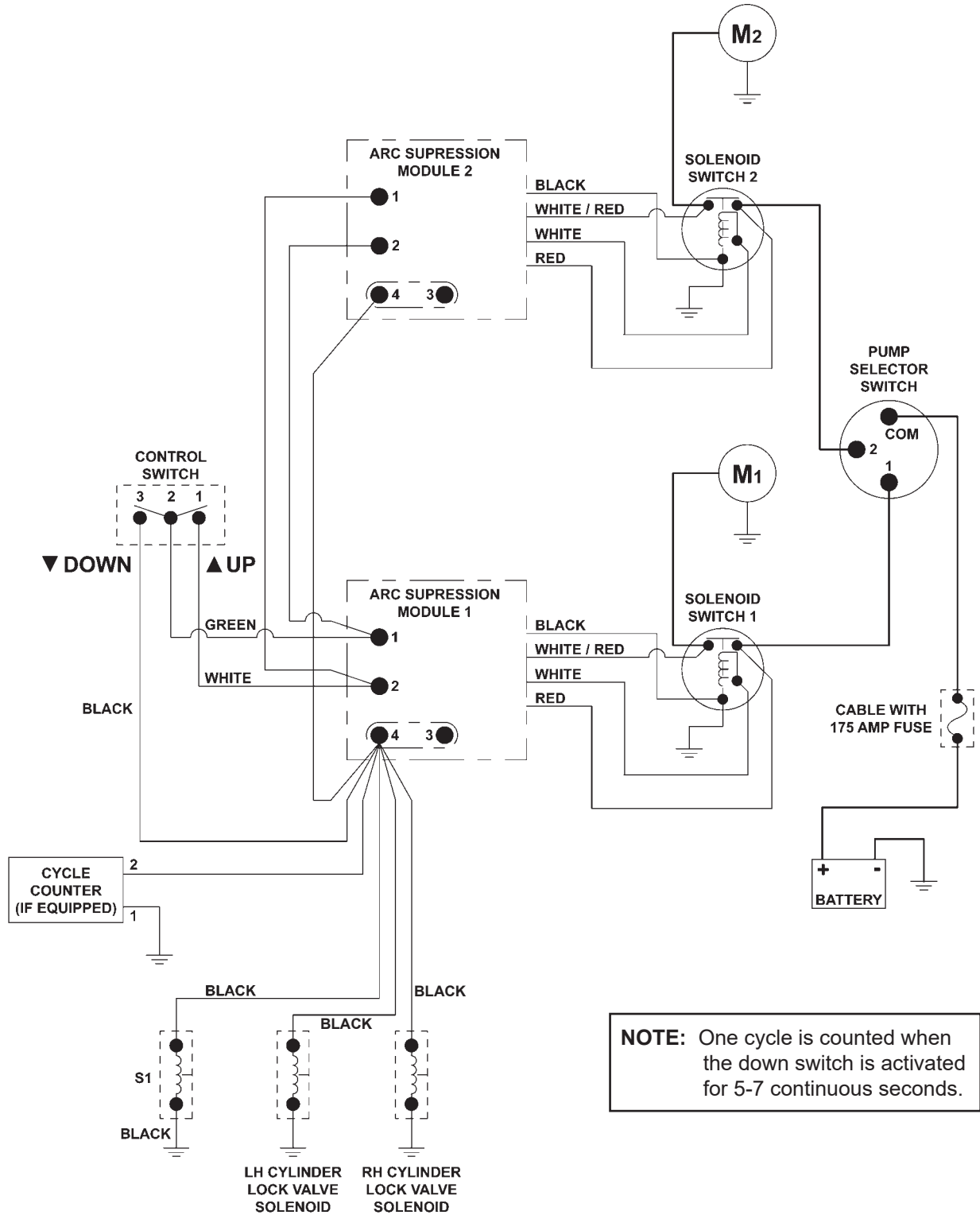

FIG. 71-1

SYSTEM DIAGRAMS

GPTWR ELECTRICAL VALUES & TORQUE SPECIFICATIONS

Solenoid Switch	12V	24V
Coil resistance:	5.4Ω @70°F. ±15%	20.1Ω @70°F. ±15%
Ampere:	2.2A	1.2A
Coil terminal torque: 10-15 lb-in max.		
Contact terminal torque: 30-35 lb-in max.		
Solenoid Valves (A, S1, & S2)		
Coil resistance:	4.0Ω @ 70°F. ±15%	26.7Ω @ 70°F. ±15%
Ampere:	3A, 2.5A @10V	
Coil terminal torque: 15-45 lb-in max.		
Valve cartridge torque: 25-30 lb-ft max.		
Coil nut torque: 15-45 lb-in		
Solenoid Lock Valve		
Coil resistance:	8.0Ω @ 70°F. ±15%	30Ω @ 70°F. ±15%
Ampere:	1.5A	0.8A
Coil nut torque: 3-4.5 lb-ft max.		
Valve cartridge torque: 18.5-22 lb-ft max.		
Digital Cycle Counter		
Input voltage	4V - 30V	4V - 30V
Ampere	<2mA	
Ground Cable		
Cap screw torque: 24 lb-ft max.		

TABLE 72-1

OPTIONS OPTIONAL LIFTGATE COMPONENTS

MISCELLANEOUS KITS	PART NO.
FRAMELESS TRAILER BRACKET, MOUNTING, 102" WIDE	282970-01
FRAMELESS TRAILER BRACKET, MOUNTING, 102" WIDE (GALVANIZED)	282970-01G
FRAMELESS TRAILER BRACKET, MOUNTING, 96" WIDE	282970-02
FRAMELESS TRAILER BRACKET, MOUNTING, 96" WIDE (GALVANIZED)	282970-02G
FRAME MOUNTING BRACKET FOR 2 OVAL LIGHTS (GALVANIZED)	282372-01G
FRAME MOUNTING BRACKET FOR 2 OVAL LIGHTS, NO FINISH (HAS RUST PREVENTIVE COAT)	282372-03
HAND PUMP, GPT SERIES	296075-01
TRAFFIC CONES	268893-01
ELECTRICAL KITS	
IN CAB ON-OFF SWITCH	250477
CIRCUIT BREAKER (150 AMP)	251576
HAND HELD CONTROL, TUKS, 120" LG (OUTSIDE VEHICLE)	263260-13
HAND HELD CONTROL, TUKS, 240" LG (OUTSIDE VEHICLE)	263260-14
HAND HELD CONTROL, TUK-A-WAY (INSIDE VEHICLE)	280570-07
STREET SIDE CONTROL, GPT	297116-01
DUAL SWITCH CONTROL, GPT	297115-01
PLATFORM FLASHING LIGHTS, TOP MOUNT, GPT	297611-01
PLATFORM FLASHING LIGHTS, SIDE MOUNT, GPT	297611-02
REAR END PROTECTION KITS FOR TRUCKS AND TRAILERS	
UNDERRIDE, 90", GPT-4 & GPT-5 (GALVANIZED) NOTE: COMPLIES WITH CANADIAN MVS REGULATIONS & FMVSS "REAR IMPACT GUARD" REQUIREMENTS	287050-01G
UNDERRIDE, 95", GPT-4 & GPT-5 (GALVANIZED) NOTE: COMPLIES WITH CANADIAN MVS REGULATIONS & FMVSS "REAR IMPACT GUARD" REQUIREMENTS	287050-02G
UNDERRIDE, 90", GPT-25 & GPT-3 (GALVANIZED) NOTE: COMPLIES WITH FMVSS "REAR IMPACT GUARD" REQUIREMENTS	287050-03G
UNDERRIDE, 95", GPT-25 & GPT-3 (GALVANIZED) NOTE: COMPLIES WITH FMVSS "REAR IMPACT GUARD" REQUIREMENTS	287050-04G
ICC BUMPER (GALVANIZED) NOTE: COMPLIES WITH OMCS REQUIREMENTS	283270-01G
DUAL STEP DOCK BUMPER KITS WITH BUMPERS	
DUAL STEP (GALVANIZED) WITH 14" LG. RUBBER BUMPERS (2.5"W X 3"H X 14"LG)	288705-01G
DUAL STEP (GALVANIZED) WITH 13.5" LG. RUBBER BUMPERS (2.9"W X 1.5"H X 13.5"LG)	288705-02G
DUAL FLEX STEP (GALVANIZED), 14" LG. RUBBER BUMPER	288705-21G
DUAL FLEX STEP (GALVANIZED), 13.5" LG. RUBBER BUMPER WITH FLEXIBLE WIRE ROPE LOWER STEP & 2.9"W X 1.5"H X 13.5"LG. POLYETHYLENE BUMPERS	288705-22G
DUAL STEP W/LIGHT (GALVANIZED), 14" LG. RUBBER BUMPERS	288705-31G
DUAL STEPS W/LIGHT (GALVANIZED), 13.5" LG. POLYETHYLENE BUMPERS	288705-32G
DUAL STEP (GALVANIZED), CURB SIDE, 14" LG. RUBBER BUMPERS	288705-03G
DUAL STEP (GALVANIZED), CURB SIDE, 13.5" LG. POLYETHYLENE BUMPERS	288705-04G

MAXON[®] 11921 Slauson Ave. Santa Fe Springs, CA. 90670 (800) 227-4116 FAX (888) 771-7713

OPTIONAL LIFTGATE COMPONENTS - Continued

DUAL STEP DOCK BUMPER KITS WITH BUMPERS - CONTINUED	
DUAL FLEX STEP (GALVANIZED), STREET SIDE, NO STEPS, 14" LG. RUBBER BUMPERS	288705-23G
DUAL FLEX STEP (PAINTED), STREET SIDE, NO STEPS, 13.5" LG. RUBBER BUMPERS	288705-24G
DUAL STEP W/LIGHT, (GALVANIZED) CURB SIDE, 14" LG. RUBBER BUMPERS	288705-33G
DUAL STEP W/LIGHT, (GALVANIZED) CURB SIDE, 13.5" LG. RUBBER BUMPERS	288705-34G
DUAL STEP DOCK BUMPER KITS WITHOUT BUMPERS	
DUAL STEP (GALVANIZED), NO BUMPERS	288705-05G
DUAL STEP (GALVANIZED), STREET SIDE, NO STEPS, NO BUMPERS	288705-06G
DUAL FLEX STEPS (GALVANIZED), NO BUMPERS	288705-25G
DUAL STEP FLEX STEPS (GALVANIZED), STREET SIDE, NO BUMPERS	288705-26G
DUAL STEPS WITH OVAL LIGHT (GALVANIZED), NO BUMPER	288705-35G
DUAL STEP W/LIGHT (GALVANIZED), STREET SIDE, NO STEPS, NO BUMPERS	288705-36G
BUMPER KITS	
PLASTIC 13.5" BUMPER (2.9"W X 1.5"H x 13.5"LG.)	288707-01
RUBBER 14" BUMPER (2.5"W X 3"H X 14"LG.)	288706-01

MAXON® 11921 Slauson Ave. Santa Fe Springs, CA. 90670 (800) 227-4116 FAX (888) 771-7713

MAXON®

PRE-DELIVERY INSPECTION FORM

Important! This pre-delivery checklist is to aid the installer in confirming the proper installation of this Maxon product. It is not a comprehensive list and does not replace the use of the installation manual. The installer is responsible for following all instructions in the installation manual.

Model: _____

Date: _____

Serial Number: _____

Technician: _____

Pre-Installation Inspection:

- Correct model
- Correct capacity
- Correct platform size
- Correct options
- Correct manuals & decals

Structural Inspection:

- Liftgate is centered on vehicle & mounted per dimensions in this manual.
- Pump box is mounted securely.
- All installation welds are done per instructions in this manual.
- All roll pins, bolts & fasteners on liftgate are tight.
- All hardware & fasteners, used to secure liftgate to vehicle, are tight.
- Ensure platform ramp touches ground when shackles are 1" above ground, and platform & flipover are level & touching the ground.

Hydraulic Inspection:

- Fluid at correct level (See **CHECKING HYDRAULIC FLUID** step in this manual.)
- No leaks from hydraulic fittings in pump box
- No leaks from hydraulic line connections

Electrical Inspection:

- Power/charge plug and terminals are clean & tight
- Individual wire connections are tight
- Circuit breaker (150A) installed in battery box (if equipped) or by truck/tractor battery
- Batteries are fully charged, all cable connections are tight & tiedowns are tight.
- Solenoid wiring connections are tight.
- Wiring harness connections are tight.
- Electrical cable connections are tight & secured clear of moving parts & sharp edges.

Operation Inspection:

NOTE: The following times are for 55" bed height, aluminum platform and flipover, Exxon Univis HVI-13 hydraulic fluid, & temperature at 70°F. Times are for reference only and may vary for larger platforms, smaller platforms, or temperature changes.

- Liftgate operates correctly using all main & optional control switches.

GPTWR-25 or -3 only

- Unloaded platform lowers in **6 to 10 sec.**
- Unloaded platform raises in **8 to 12 sec.**

GPTWR-4

- Unloaded platform lowers in **7 to 11 sec.**
- Unloaded platform raises in **9 to 13 sec.**

GPTWR-5

- Unloaded platform lowers in **10 to 14 sec.**
- Unloaded platform raises in **12 to 16 sec.**
- All GPTWR:** Unloaded platform raises and lowers evenly. At the extension plate, platform must not be more than 1/8" uneven, from side to side.
- All GPTWR:** Platform stores securely under vehicle body.
- Cycle counter indicates all up & down cycles.
- Decals are in correct location and legible.

Verify all lights are operational

- Platform lights turn **ON** when platform is unfolded, and turn **OFF** when platform is stowed.
- Taillights, stop lights, turn lights, and backup lights turn **ON** and **OFF** correctly.

