

SOLAR POWER SYSTEM

INSTALLATION MANUAL

ROAD WARRIOR KIT





SOLAR POWER SYSTEM

INSTALLATION
MANUAL

ROAD WARRIOR KIT

TABLE OF CONTENTS

TOOLS REQUIRED	2
BILL OF MATERIAL	5
PRE-INSTALL VOLTAGE CHECK	6
INSTALLATION PROCEDURE: 4 SIMPLE PARTS	8
PART 1: INSTALL MODULES	8
PART 2: MOUNTING THE SYSTEM	10
PART 3: STRAIN RELIEF	12
PART 4: WIRING THE SYSTEM	15
TESTING AND MAINTENANCE	17

TOOLS REQUIRED



Screwdriver



DC Clamp-on Multimeter



Utility Knife



Socket Wrenches



Measuring Tape



Gloves



Eye Protection



*Primer

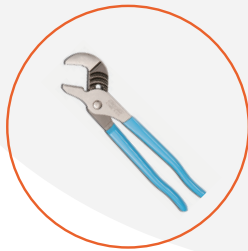

Plier



Wire Cutter



**Rubber Roller

*Disclaimer: Contact Merlin Solar for details on primer type

**If rubber roller not available use microfiber rag

CAUTION

Points to check before wiring.

- Wear insulated gloves when modules are exposed to light.
- Use a multimeter for volts, amps, resistance, and continuity capable of measuring DC and AC up to 600 volts and 40 Amps.
- Modules should be mounted before operating electrical components
- Installation of modules should only be performed by a qualified licensed professional
- Do not direct concentrated sunlight or artificially concentrated sunlight on the module
- Do not wear metallic jewelry to avoid electric shock during installation
- Do not disconnect the cables under load
- Do not allow children or unauthorized personnel near the area of module installation
- Only work under dry weather conditions and always keep the modules and tools dry during installation
- Do not install modules where flammable gases or vapors are present

BILL OF MATERIAL

Solar Panel Assembly		
Component	#	Unit
Road Warrior Solar Panel(s)	1-4	pc
Charge Controller Assembly		
Component	#	Unit
Merlin Optimized Charge Controller with Inline Fuse, Plug & Play	1	pc
Battery Cable with Deutsch Connector/Ring Terminals	1	2.5 ft, 5 ft, 10 ft
Solar Wire Assembly		
Component	#	Unit
Jacketed Home Run Cable with Staubli MC4 Connectors	1	20 ft, 50 ft
Mounting Hardware		
Component	#	Unit
Mounting Hardware Kit, Screw, Cable Clamp, Warning Label, Wire Tie	1	pc
Edge Tape	1	pc



Battery Cable

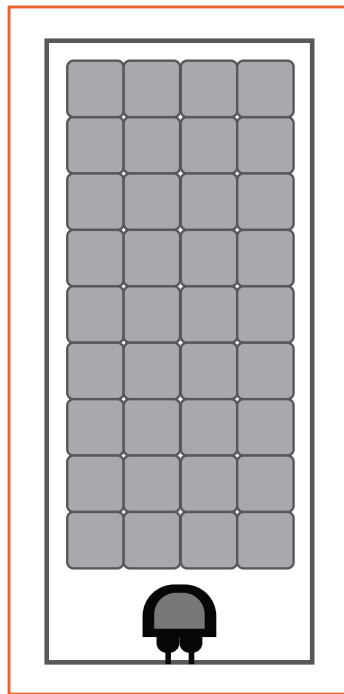

Merlin Solar® Road Warrior PV Module with Adhesive Backing



Home Run Cable



Mounting Hardware and Edge Tape



Merlin Solar® TS10/15/30 Charge Controller with Fuse

PRE-INSTALL VOLTAGE CHECK

Prior to installing the panel, ensure the panel is producing power.

- This can be done by using a multimeter
- Ensure the panel has access to sunlight
- Insert **RED (+)** meter cable into **PV+** cable MC4 connector
- Insert **BLACK (-)** meter cable into **PV-** cable MC4 connector
 - Note: contact pins are located in the center of the connectors
- If panel is functioning properly the Voltage should read above 3VDC
 - If the voltage reads negative the positive and negative leads from the panel are inverse
- If the panel is non-functional the voltage will read 0V
 - Please contact MERLIN® straight away for further steps

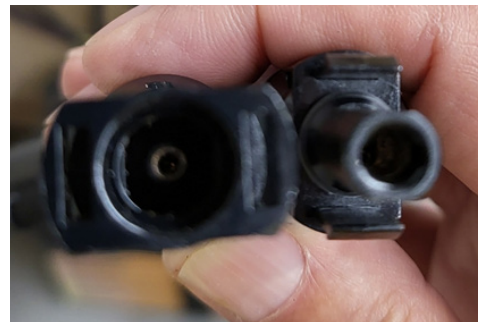

MC4 Connectors



RED (+) meter cable into PV+ cable MC4 connector



Insert BLACK (-) meter cable into PV- cable MC4 connector



Multimeter displaying the connected PV's voltage



THIS PAGE IS
INTENTIONALLY LEFT BLANK

INSTALLATION PROCEDURE: 4 SIMPLE PARTS

PART 1 INSTALL MODULES

Assess Condition Of The Mounting Surface

- Observe and measure surface obstructions.
- Ascertain which areas need extensive cleaning.
- **Surface must be at least 60F / 15C.**
- 3M Tape Primer 94 may be required for use if the installation surface is rough, textured, plastic and/or not smooth & flat. Contact Merlin for further details and instruction. Tape primer may also be required if the installation surface is below 60F / 15C.
- ★ Apply isopropyl alcohol, acetone, or any quality industrial surface cleaner/ degreaser that does not leave any surface residue to a microfiber rag and apply with force to the mounting surface to remove any substance that would limit adhesion. Cleaner may be applied directly to surface, but absolutely no cleaner residue can remain on mounting surface prior to panel installation.

Install Panel

- Mark mounting location of panel.
- Hold module in place, then remove several inches of liner from one end.
- ★ **PRO TIP:** Place end of module aligned to marked line. Peel off around 12 inches of liner from below module, making sure it is aligned. Partially remove and stick the module on in 1 foot increments, making sure module conforms to the surface.
- Roll out the module with rubber roller or microfiber rag.

SCAN HERE FOR INSTALL VIDEO

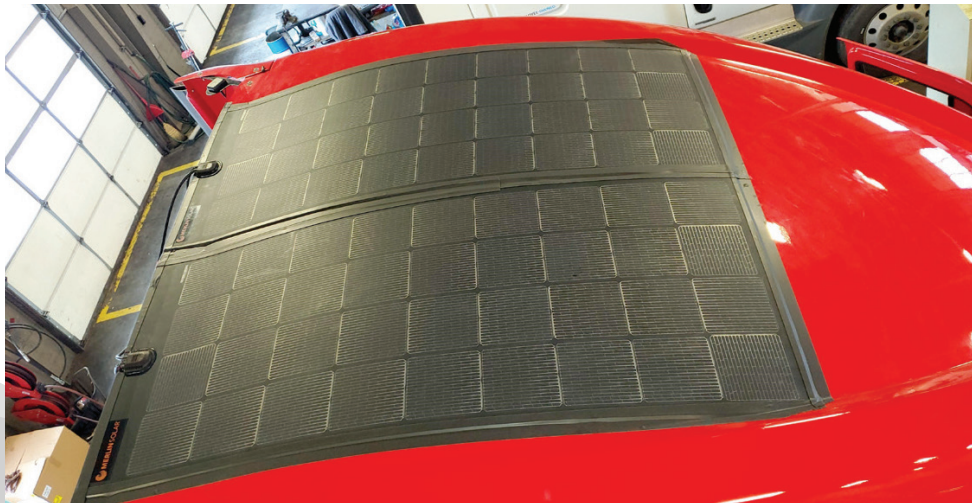

Example installation of two MERLIN® RoadWarrior modules on a truck.

PART 1 INSTALL MODULES (CONTINUED)

NOTE

1. Use of edge tape is required.
2. Place edge tape along sides of the module, 0.25 inches away from the edge of the cells.

★ **PRO TIP:** Ensure that the applied edge tape does not cover any portion of the solar cells, especially the edges.

EDGE TAPE PLACEMENT

Correct

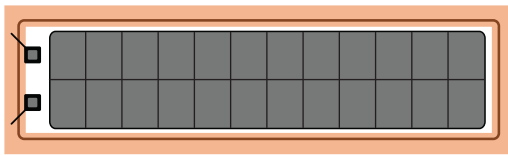

Edge tape is 0.25 Inches away from the edge of the cells.

Incorrect

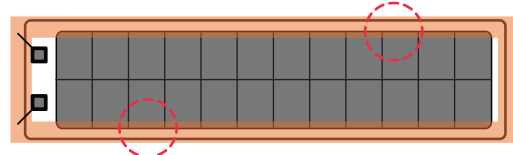

Edge tape is covering the edges of the solar cells.

STEP 1

Clean area thoroughly with cleaner as described above before installation.

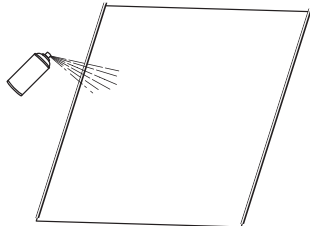

STEP 2

Mark mounting location. Apply primer to specified mounting area.

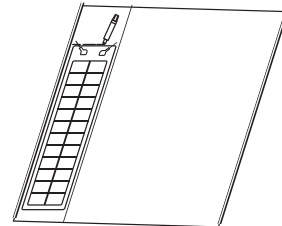

STEP 3

Hold module in place then remove several inches of liner from one end. Place end of module aligned to marked line. Peel off remaining liner from below module.

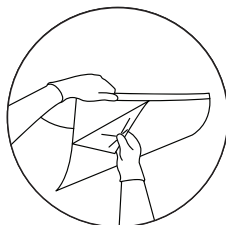

STEP 4

Roll out the module with the rubber roller. Avoid excessive pressure.

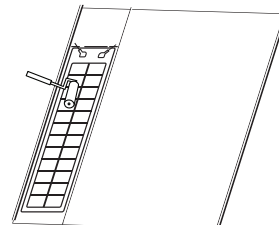

PART 2 MOUNTING THE CHARGE CONTROLLER

- The charge controller is designed to mount away from direct heat, water, salt, snow, ice, and debris.
- Mount the unit and ensure the heat fins have sufficient air flow.
 - See page 12 for detailed mounting instructions.
- Use the charge controller foot pad to create a hole template to pre-drill mounting holes.

Note:

Make sure the in-line fuse is connected on the (+) side of the battery side of the charge controller. If you have a busman disconnect, make sure it is not near an area where it can disconnect by touching other cables or components.

CHARGE CONTROLLER DIAGRAM

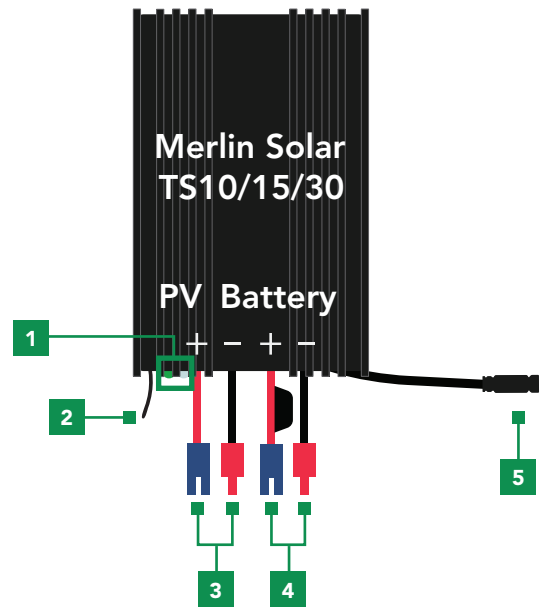

1. LED lights (visual use only, **see page 18** for more information)
2. Thermistor probe (**do not** cut or remove)
3. PV cables (Solar Input) positive (+) & negative (-)
4. Battery cables (Power output) positive (+) & negative (-)
5. Communication port (**do not** cut or remove)

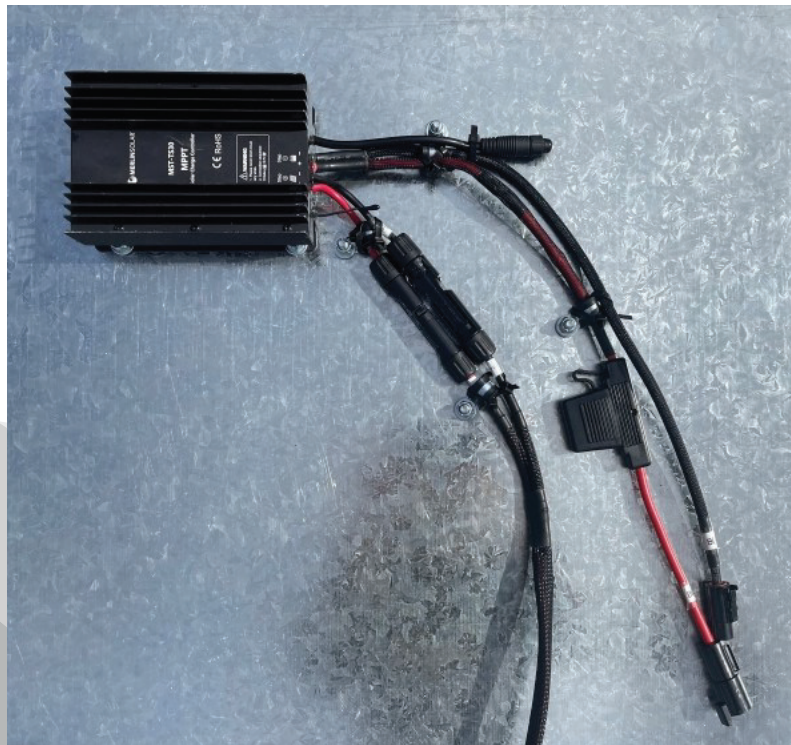

MERLIN® TS charge controller properly mounted and with strain relief.

INSTALLATION MOUNTING LOCATION INSTRUCTIONS

- Do NOT install the **Charge Controller** and **Non-Sealed or Open Venting Type Batteries** in the same enclosed space.
- Do NOT install the **Charge Controller** in an **Airtight or Well-Sealed Enclosure** where battery gas may accumulate and cannot properly vent.
- When installing the controller, ensure there is sufficient air flow through the controller's heat sink.
 - ⚠ **CAUTION:** Leave **AT LEAST 150 mm / 6"** of space above and below the controller for natural convection cooling.
 - ⚠ **CAUTION:** If installed in an airtight or well-sealed enclosure, ensure closure can reliably dissipate heat.
 - ⚠ **CAUTION:** Make sure the airflow around the charge controller is not obstructed.

PART 3 STRAIN RELIEF INSTRUCTIONS

OPTION 1: HORIZONTAL MOUNT (RECOMMENDED)

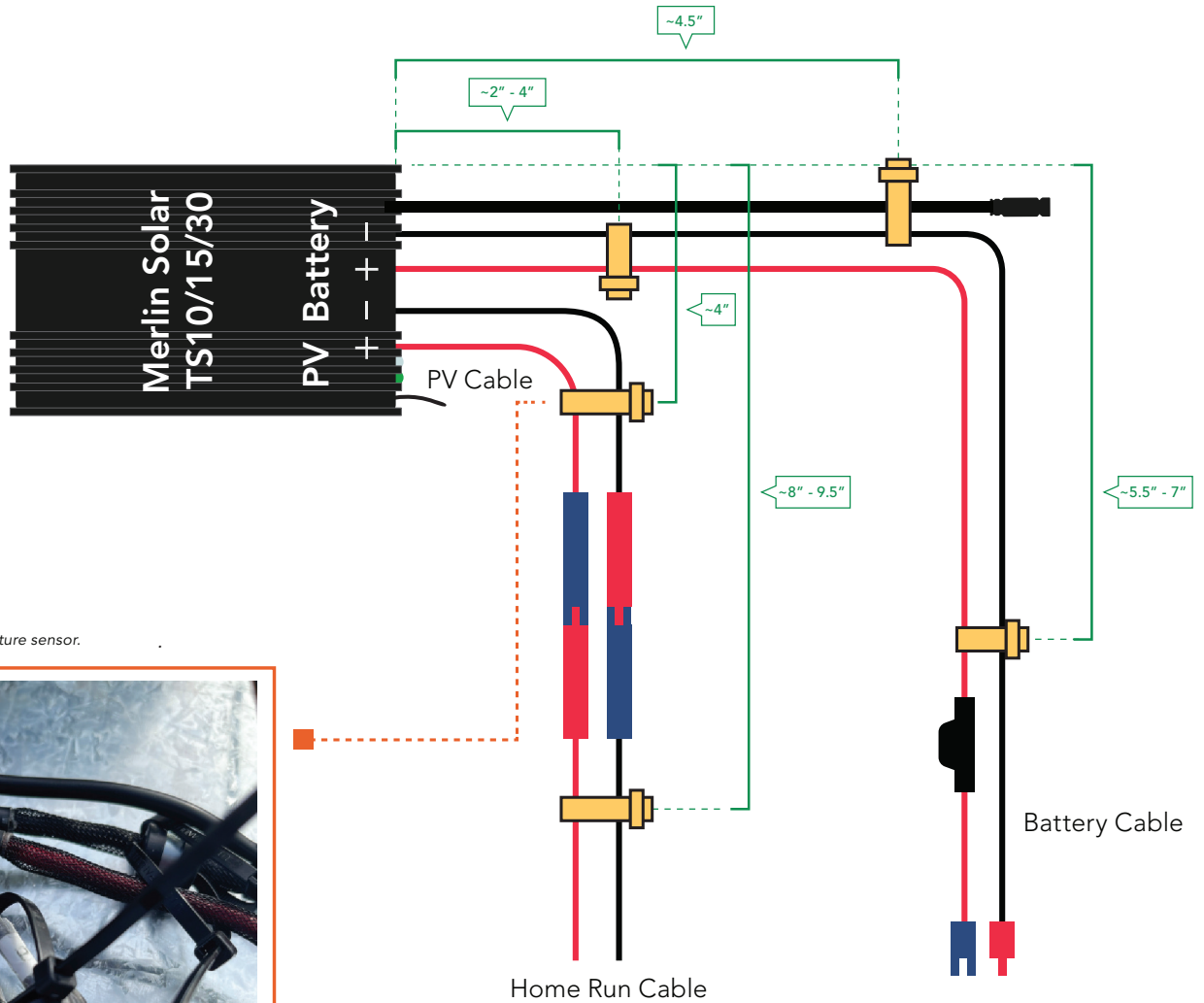

★ Do not zip tie the temperature sensor.



PART 3 STRAIN RELIEF INSTRUCTIONS (CONTINUED)

OPTION 2: VERTICAL MOUNT (RECOMMENDED)

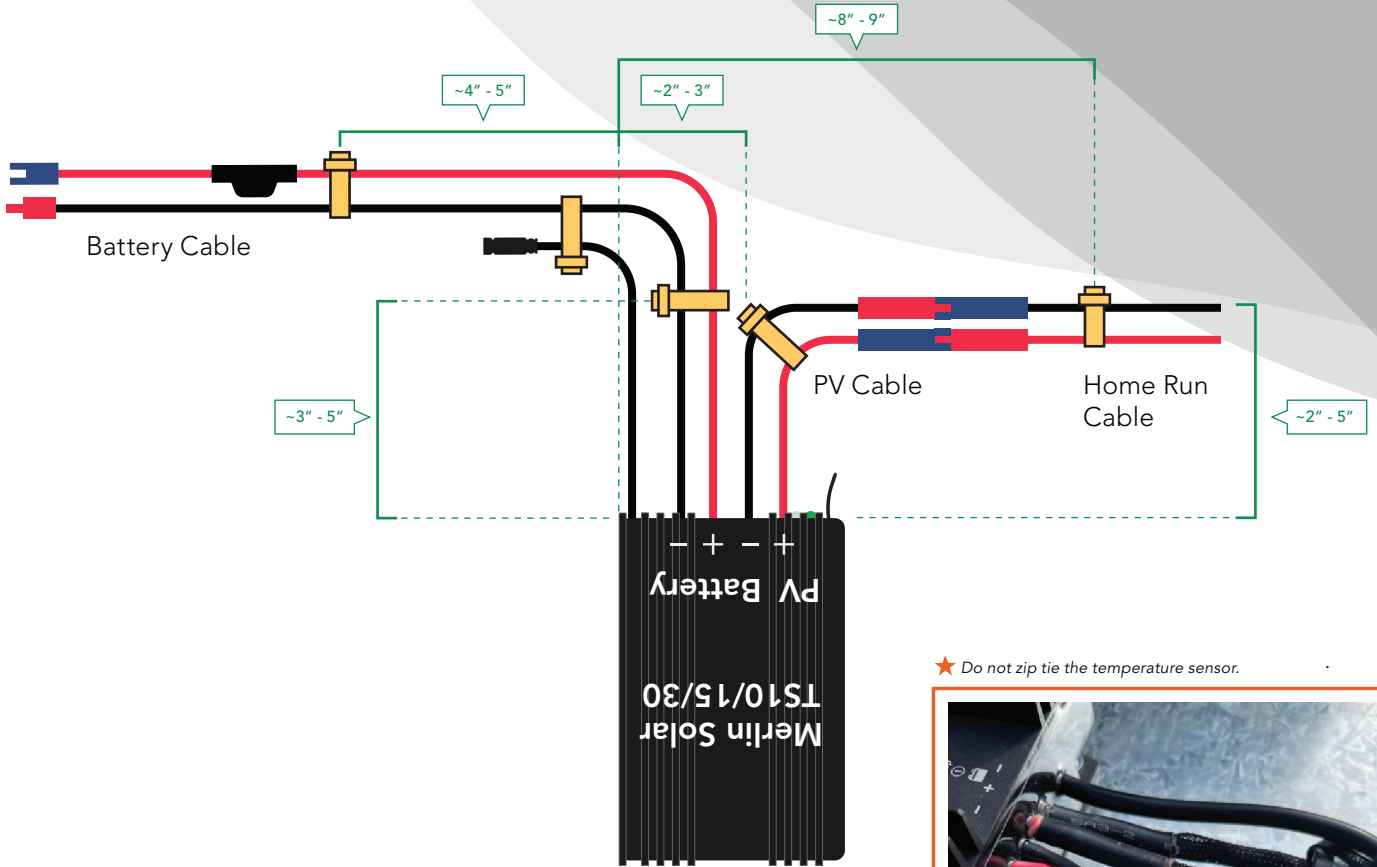

★ Do not zip tie the temperature sensor.

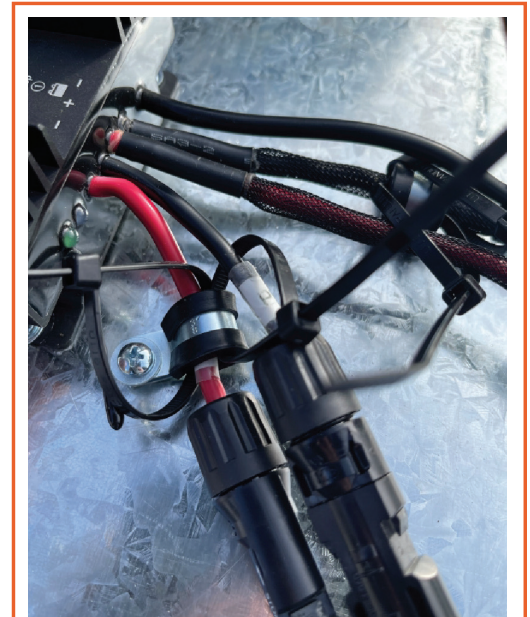

PART 3 STRAIN RELIEF INSTRUCTIONS (CONTINUED)

CHARGE CONTROLLER MOUNTING & STRAIN RELIEF

Option 1: [1/4"–20 x 3/4"] or [#10–32 x 3/4"] Machine Screws, Flat Washers, and Nylock Nuts:

1. Place charge controller on desired mounting location
2. Ensure surrounding area is free of obstructions and has sufficient air flow
3. Mark mounting hole locations using charge controller mounting flange template
4. Equip 1/4" drill bit to driver and drill out marked holes
 - A. If necessary, use lubrication oil
5. Place charge controller on mounting holes and fasten down as shown in visual stack (see below)
 - A. Note: Screw length may need to increase depending on the thickness of the installation surface.
 - B. Pro Tip: Use an open-end wrench and a piece of tape to hold the nylock nut to the wrench. Slide the wrench into the controller flange and slowly thread the machine screw from the outside to bite into the nylock nut.

VISUAL STACK

1. Nylock Nut
2. Flat Washer
3. Charge Controller Chassis
4. Installation Surface
5. Flat Washer
6. Machine Screw

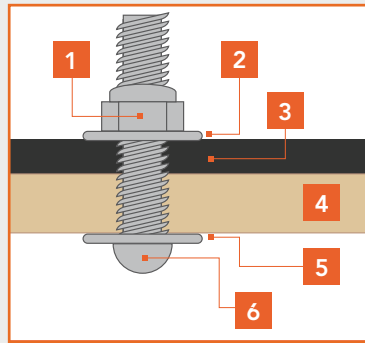

Option 2: 1/4" or 3/16" Blind Rivet:

1. Place charge controller on desired mounting location
2. Ensure surrounding area is free of obstructions and has sufficient air flow
3. Mark mounting hole locations using charge controller mounting flange template
4. Equip drill bit to driver and drill marked holes
 - A. Equip 3/16" drill bit for 3/16" blind rivet
 - B. Equip 1/4" drill bit for 1/4" blind rivet
 - C. If necessary, use lubrication oil
5. You then load the pop rivet into the rivet gun mandrel first, so the sleeve is pointing outward.
6. Insert the body of the pop rivet all the way into the pre-drilled hole. The flange of the rivet should be flush to the installation surface.
 - A. For 3/16" blind rivet, flat washers need to be used on the outside of the installation surface and on the inside of the controller flange.
7. Squeeze the trigger of the power rivet gun (or apply pressure to the levers on the manual rivet gun) until you hear the snap sound that indicates the mandrel has been removed. Once the mandrel is snapped off, the collar becomes the rivet head.
8. Lastly, the mandrel is collected. You will have to collect the mandrel yourself if you are using a manual rivet tool. Most power rivet guns have a built-in receptacle to capture the mandrel once it is removed.



PART 4 WIRING THE SYSTEM

WIRING PRECAUTIONS

- Exercise caution when wiring. There is a risk of high-voltage due to the potential of the photovoltaic (solar) array to generate a very high open-circuit voltage.

⚠ CAUTION: Before wiring, disconnect the circuit breaker or fast-blow fuse.

- Poor connection points and/or corroded/frayed wires may cause extreme heat which will melt the wire insulation layer, burn the surrounding materials, and can even cause fire.

⚠ CAUTION: It is REQUIRED to ensure that the connectors are tightened

⚠ CAUTION: It is REQUIRED that all wires have proper strain relief methods in place (see pages 10 - 13)

- When the RS485 communication cable is not in use, screw the interface waterproof cap tightly to prevent water damage to the communication chip.
- After confirming the panel is functioning (see page 6), the procedure for wiring the system MUST be followed as shown in the steps below.

! WARNING: If the steps outlined below are not followed IN ORDER the system WILL NOT function properly.

! WARNING – FIRE HAZARD: IF the battery connection is reversed, the charge controller is going to be damaged and will create a thermal event.

PART 4 WIRING THE SYSTEM (CONTINUED)

STEP 1

1. Connect positive battery cable ring terminal to battery (+) terminal on battery.
2. Connect negative battery cable ring terminal to battery (-) terminal on battery.



STEP 2

1. Connect positive battery cable to battery (+) terminal on charge controller.
2. Connect negative battery cable to battery (-) terminal on charge controller.

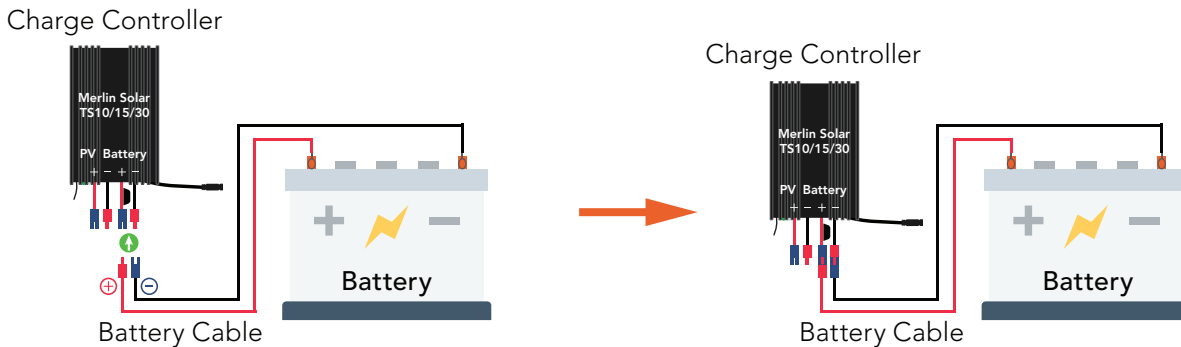

STEP 3

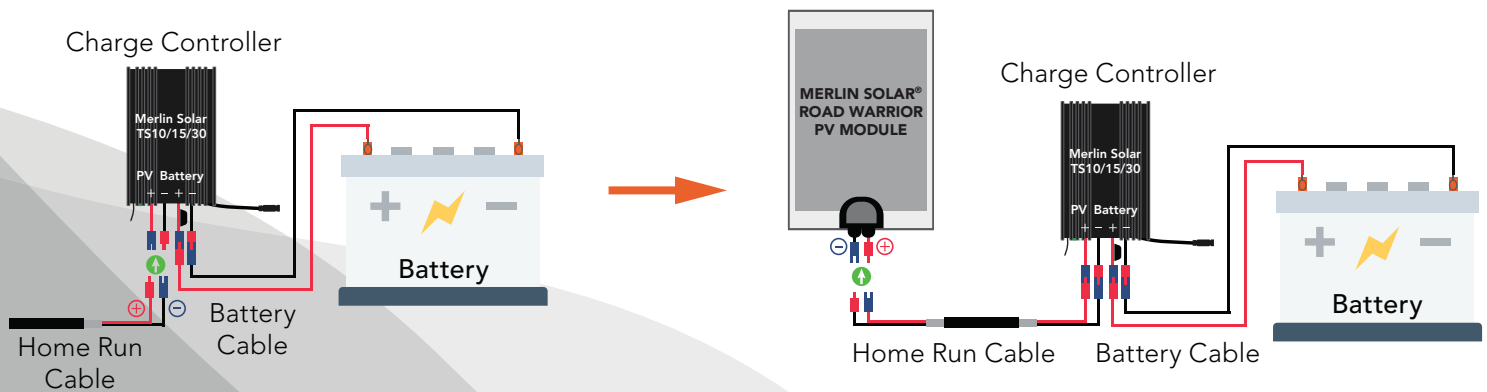

1. Connect positive home run cable to PV (+) terminal on charge controller.
2. Connect negative home run cable to PV (-) terminal on charge controller.
3. Connect home run cables to cables on Merlin Solar panel.

Note: PV = solar panel



PART 4 WIRING THE SYSTEM (CONTINUED)

STEP 4: LED INDICATORS

Indicator	Color	Status	Instruction
	Green	On Solid	—
		OFF	No PV voltage (night time) or PV connection problem
		Slowly Flashing (1 Hz)	In charging
		Fast Flashing (4 Hz)	PV overvoltage
	Green	On Solid	Battery is normal
		Slowly Flashing (1 Hz)	Battery charges full
		Fast Flashing (4 Hz)	Battery overvoltage
	Orange	On Solid	Battery undervoltage
	Red	Fast Flashing (4 Hz)	Battery overheating Lithium battery low temperature
Charging Indicator (green) & Battery Indicator (orange) flashing simultaneously			Battery overheating Lithium battery low temperature
<p>*When the battery type is a lithium battery, the controller does not recognize the system voltage automatically.</p>			

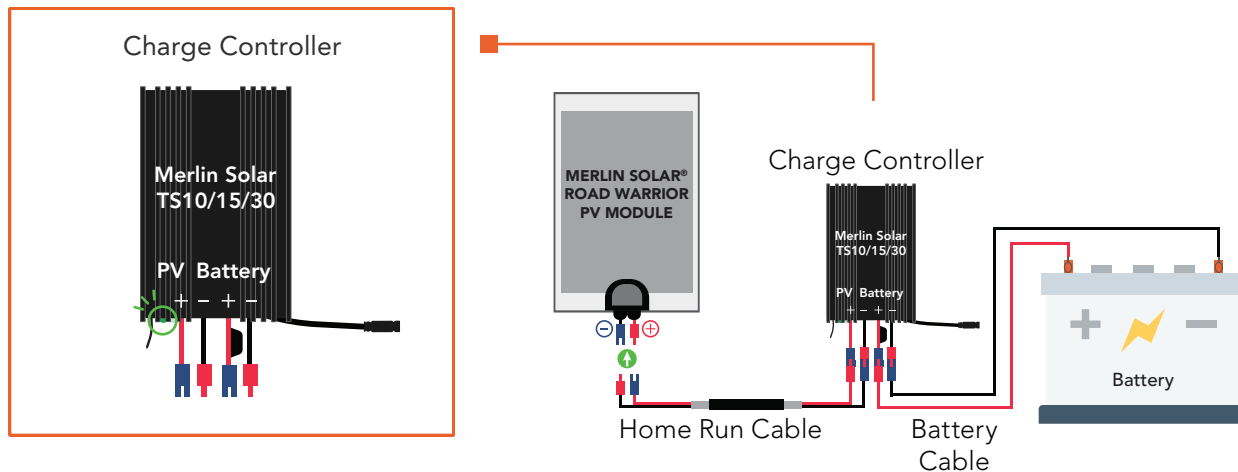

STEP 5

1. When disconnecting the system, the sequence will be reversed.



TESTING AND MAINTENANCE

System Check

- Ensure that charge controller is receiving power from the PV array by checking that the light on the charge controller is blinking green, as shown on the right.
- Use DC clamp-on multimeter to measure amperage of PV wire.
 - Positive HR cable to controller: [0.1-40A]
 - Positive cable to battery: [0-40A]
- If controller does not respond, ensure connections are sound. Please note if batteries are full, no current will be available, this is an indication that the system is working properly. Check again when batteries are not full.
- Check panels at least once a month for dirt and debris, and clean with water as needed". This is to mitigate hotspot issues that could arise if dirt, bird poop, or other material is obstructing cells over a long period of time.
- After replacing the batteries, make sure the solar panels are connected again and that the breaker is back in the ON position (if applicable).
- Tighten all battery/charge controller connections. Use a proper torque wrench to tighten batteries, following battery manufacturer specs.
- Pull test all floating connections.

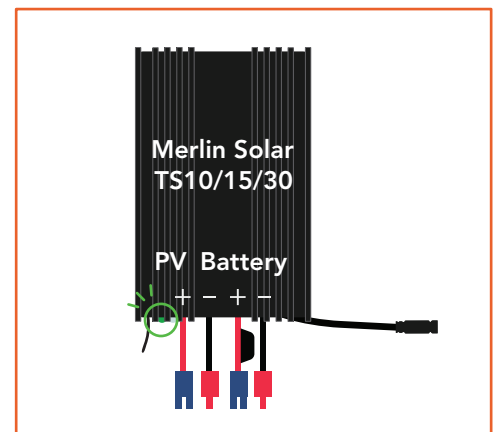

Note:

1. Voc is voltage coming out of the HR cable to the controller
2. The Voc of the panel array can be significantly higher than the charging voltage. Check specific modules to determine appropriate voltage ranges. If the Voc of the array exceeds 48V, make sure a safety breaker is installed on the PV side of the circuit.
3. Based on state of charge of the battery, if you have a full battery the current might be zero...meaning the currents don't need to match (bulk, absorption, float).

TESTING AND MAINTENANCE (CONTINUED)

System Maintenance

- Clean surface of panels as needed with isopropyl alcohol or other degreaser.
- When replacing batteries, ensure that terminals are cleaned as well. Make sure the solar panels are disconnected by removing the fuse or using the breaker (if available).
- After replacing the batteries, make sure the solar panels are connected again and that the breaker is back in the ON position (if applicable).

! In the rare event that you need to jump start the vehicle, make sure solar panels are disconnected.

Preventative Maintenance

- To maintain the best long-term performance for your charge controller, it is recommended to conduct inspections **Four Times per Year**.
- Make sure the airflow around the charge controller is not obstructed and remove any dirt or debris from the heat sink.
- Check if the insulation layers of all exposed wires are damaged due to sun exposure, friction with other objects nearby, dry rot, destruction of insects or rodents, etc.
 - If so, it is necessary to repair or replace the wire. Contact Merlin for additional support.
- Reference the LED Indicator table (see page 17) to gather the charge controllers state of function.
 - Contact Merlin for additional support.
- Check all wiring terminals for corrosion, insulation damage, signs of high temperature, and burning/discoloration.
 - If damage is present, replace the affected component.
- Ensure all terminal screws are properly tightened.
- Check for dirt, insects nesting and corrosion and clean as required.
- If using a lightning arrester and it has failed, replace it in time to protect the charge controller, and other devices, from be damaged by lightning.
 - Please note to take corrective actions for any malfunctions or error indications if necessary.

! WARNING: Danger, electric shock hazards! Make sure that all power supplies to the controller have been disconnected before any system maintenance is performed!

Disclaimer of Liability

The information contained in this manual is based on MST's knowledge and experience. Such information and suggestions do not constitute a warranty and MST does not assume responsibility and expressly disclaims liability for loss, damage, or expense arising out of, or in any way connected with the installation, operation, use, or maintenance as described in this manual. It is assumed that MST has no responsibility for any infringement of patents or other rights of third parties which made result from use of modules. MST reserve the right to make changes to the product, specification, or to the manual without prior notice.

Photovoltaic Modules Limited Warranty

Merlin Solar Technologies, Inc. warrants to the first consumer purchaser that this Merlin Solar Technologies, Inc. brand product (the "Product"), when shipped in its original container, will be free from defective workmanship and materials, and agrees that it will, at its option, either repair the defect or replace the defective Product or part thereof with a new or remanufactured equivalent at no charge to the purchaser for parts or labor for the period(s) set forth below. This warranty does not apply to any appearance items of the Product nor to the additional excluded item(s) set forth below nor to any Product the exterior of which has been damaged or defaced, which has been subjected to misuse, abnormal service or handling, or which has been altered or modified in design or construction.

In order to enforce the rights under this limited warranty, the purchaser should follow the steps set forth below and provide proof of purchase to the servicer. The limited warranty described herein is in addition to whatever implied warranties may be granted to purchasers by law. **ALL IMPLIED WARRANTIES INCLUDING THE WARRANTIES OF MERCHANTABILITY AND FITNESS FOR USE ARE LIMITED TO THE PERIOD(S) FROM THE DATE OF THE PURCHASE SET FORTH BELOW.** Some states do not allow limitations on how long an implied warranty lasts, so the above limitation may not apply to you. Neither the sales personnel of the seller nor any other person is authorized to make any warranties other than those described herein, or to extend the duration of any warranties beyond the time period described above on behalf of Merlin Solar Technologies, Inc. The warranties described herein shall be the sole and exclusive warranties granted by Merlin Solar Technologies, Inc. and shall be the sole and exclusive remedy available to the purchaser. Correction of defects, in the manner and for the period of time described herein, shall constitute complete fulfillment of all liabilities and responsibilities of Merlin Solar Technologies, Inc. to the purchaser with respect to the Product and shall constitute full satisfaction of all claims, whether based on contract, negligence, strict liability or otherwise. In no event shall Merlin Solar Technologies, Inc. be liable, or in any way responsible, for any damages or defects in the Product which were caused by repairs or attempted repairs performed by anyone other than an authorized servicer. Nor shall Merlin Solar Technologies, Inc. be liable or in any way responsible for any incidental or consequential economic or property damage. Some states do not allow the exclusion of incidental or consequential damages, so the above exclusion may not apply to you. **THIS WARRANTY GIVES YOU SPECIFIC LEGAL RIGHTS. YOU MAY ALSO HAVE OTHER RIGHTS, WHICH VARY FROM STATE TO STATE.**

Product Model Number & Description

MST Transportation Kits
(Be sure to have this information available when you need service for your product.)

Warranty Period for this Product

The warranty period for material defects and workmanship is 5 years from installation date. This warranty is transferable when product remains installed in original location at the time of product warranty registration.

ADDITIONAL ITEM(S) EXCLUDED FROM WARRANTY COVERAGE

Warranty coverage does not apply when:

- The product is improperly installed
- The product is subjected to abuse, damage from external impacts
- The product is subjected to improper voltage or power surges or abnormal environmental conditions, lightning, floods, other condition beyond manufacturer's control
- The components in the construction base on which the module is mounted are defective
- External corrosion, mold discoloration or the like occurs

