

TRAILER SIDE DOOR SLIDELIFT® SERIES

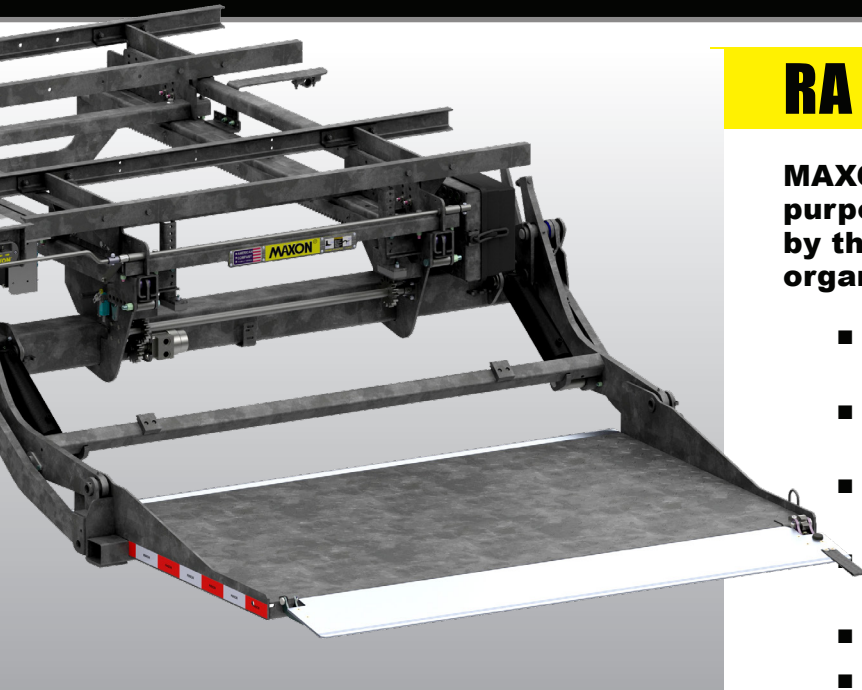

The RA Series



RA SPECIFICATIONS

MAXON's new Trailer Side Door Gate is purpose designed, made to last and supported by the best pre- and after sales service organization in the industry

- The RA side door slider-type gate comes in 3,500 lbs and 4,500 lbs capacities
- Two hydraulic lifting cylinders with bi-directional lock valves
- The RA comes completely assembled and prefilled with hydraulic oil
- Wide arm design for stability and maximum side rail clearance capabilities
- Greaseable pins and bushings on all pivot points
- Flashing platform lights standard
- Center mounted junction box enables easy and secure connections for power as well as axillary items such as secondary switches
- **Galvanized Finish – STANDARD!**

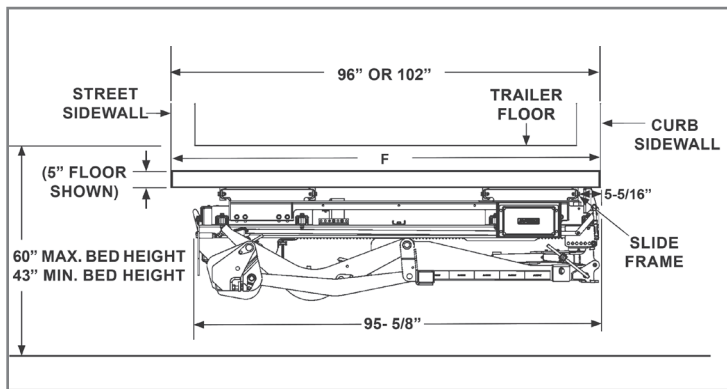

Lift Dimensions and Mounting Requirements

NOTE: Please review appropriate liftgate installation manual for full vehicle and or body requirements to ensure proper fitment.

Model Capacity	Overall Weight	Platform & Ramp Options	Bed Height
RA-35 (3,500 Lbs.)	1,105 LBS. to 1,315 LBS.	86" X 79" (55" + 24") +12" Single or Dual Retention Ramp	43" Laden 60" Unladen
		1 Piece Platform 86" X 55"+12" Single or Dual Retention Ramp	
60" X 79" (55" + 24") +12" Single Retention Ramp			
1 Piece Platform 60" X 55"+12" Single Retention Ramp			
RA-45 (4,500 Lbs.)		52" X 79" (55" + 24") +12" Single Retention Ramp	
		1 Piece Platform 52" X 55"+12" Single Retention Ramp	

TRAILER SIDE DOOR SLIDELIFT® SERIES



The RA Series

Standard Equipment

- Galvanized finish
- Two hydraulic lifting cylinders with bi-directional lock valves
- Hydraulic gear drive for in and out movement
- Potted toggle switches (Up/Down & In/Out)
- Adjustable stops (in/Out & Up/Down)
- Mechanical transit latch
- Electric transit signal
- Stow Light

Optional Features

- Hand held control
- Dual Pump & Motor
- MAX ECU
- Protective rubber mud guard
- Safety Light Kit
- Railing installation kit

Distributed by:

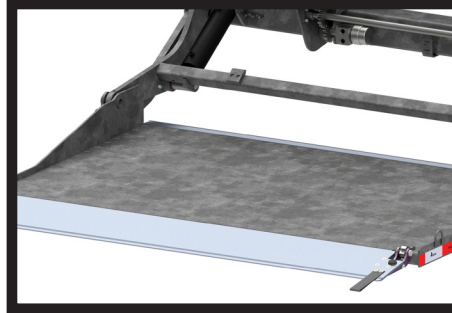

Large Platform

RA design utilizes full trailer width resulting in the largest platform sizes possible

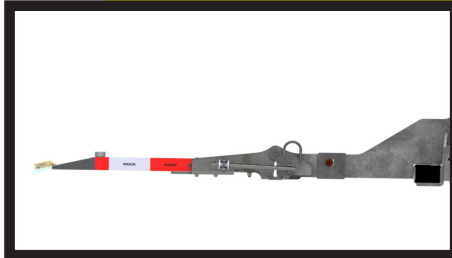

Level Ride Platform

The RA rides level all the way to the ground which allows loads to be easily loaded or unloaded



Hydraulic Locking System

The hydraulic system automatically locks the gate as soon as the operator releases the control switch



Stow Light

Indicator light that signals if the gate is correctly stowed or in operation

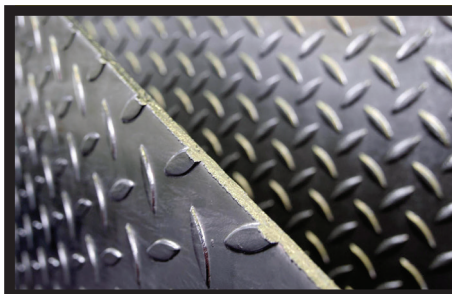

GALVANIZED Finish

For the utmost in corrosion protection, RA liftgates are shipped with a galvanized finish

M283-0424