

M-16-15
REV. B
AUGUST 2017

Maintenance Manual Contains:

- Warranty Information
- Warnings
- Service Time Chart
- Periodic Maintenance Checklist
- Service and Maintenance Instructions
- Decals
- Hydraulic & Electrical System Diagrams
- Troubleshooting

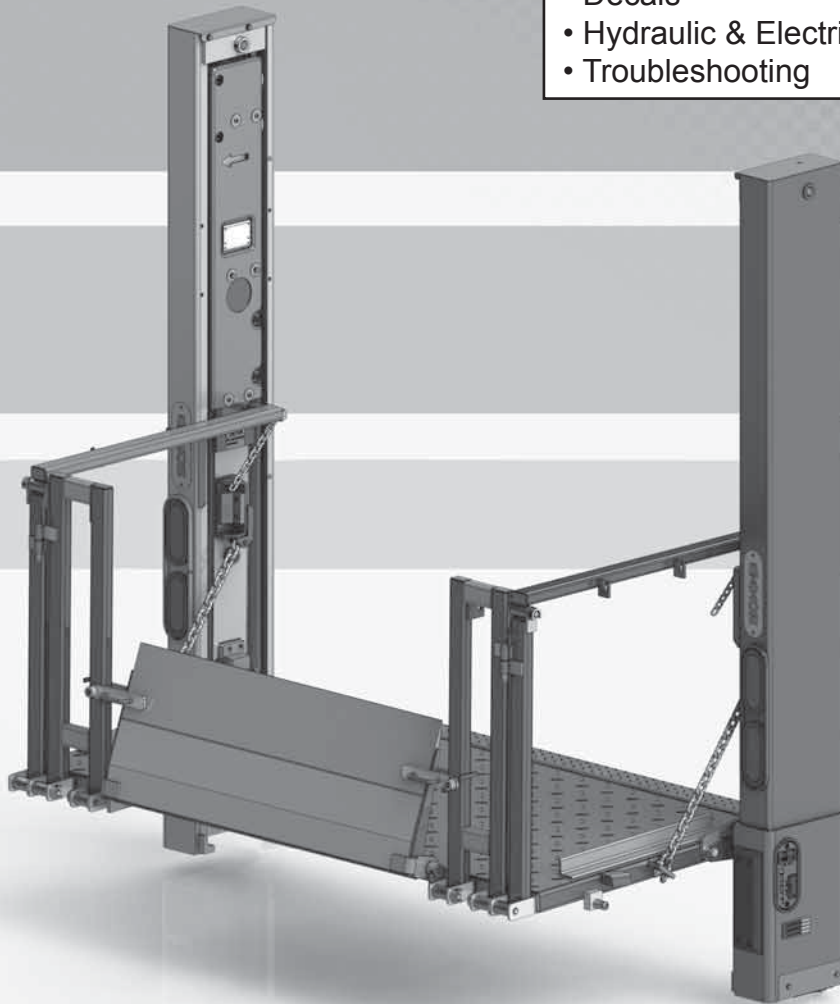

MAXON[®]
LIFT CORP.

BMR-CS

MAINTENANCE MANUAL

MAXON[®]

LIFT CORP.

11921 Slauson Ave.
Santa Fe Springs, CA. 90670

CUSTOMER SERVICE:

TELEPHONE (562) 464-0099 TOLL FREE (800) 227-4116

FAX: (888) 771-7713

NOTE: For latest version of all Manuals (and replacements), download the
Manuals from Maxon's website at www.maxonlift.com.

WARRANTY/ RMA POLICY & PROCEDURE

LIFTGATE WARRANTY

Type of Warranty: Full Parts and Labor

Term of Warranty: Standard Liftgates - 2 years from ship date or 6,000 cycles
Premium Liftgates - 2 years from ship date or 10,000 cycles

This warranty shall not apply unless the product is installed, operated and maintained in accordance with MAXON Lift's specifications as set forth in MAXON Lift's Installation, Operation and Maintenance manuals. This warranty does not cover normal wear, maintenance or adjustments, damage or malfunction caused by improper handling, installation, abuse, misuse, negligence, or carelessness of operation. In addition, this warranty does not cover equipment that has had unauthorized modifications or alterations made to the product.

MAXON agrees to replace any components which are found to be defective during the first 2 years of service, and will reimburse for labor based on MAXON's Liftgate Warranty Flat Rate Schedule. (Copy of the Flat Rate is available at www.maxonlift.com.)

All warranty repairs must be performed by an authorized MAXON warranty facility. For any repairs that may exceed \$500, including parts and labor, MAXON's Technical Service Department must be notified and an "Authorization Number" obtained.

All claims for warranty must be received within 30 Days of the repair date, and include the following information:

1. Liftgate Model Number and Serial Number
2. The End User must be referenced on the claim
3. Detailed Description of Problem
4. Corrective Action Taken, and Date of Repair
5. Parts used for Repair, Including MAXON Part Number(s)
6. MAXON R.M.A. # and/or Authorization # if applicable (see below)
7. Person contacted at MAXON if applicable
8. Claim must show detailed information i.e. Labor rate and hours of work performed

Warranty claims can also be placed online at www.maxonlift.com. Online claims will be given priority processing.

All claims for warranty will be denied if paperwork has not been received or claim submitted via Maxon website for processing by MAXON's Warranty Department within 30 days of repair date.

All components may be subject to return for inspection, prior to the claim being processed. MAXON products may not be returned without prior written approval from MAXON's Technical Service Department. Returns must be accompanied by a copy of the original invoice or reference with original invoice number and are subject to a credit deduction to cover handling charges and any necessary reconditioning costs. **Unauthorized returns will be refused and will become the responsibility of the returnee.**

Any goods being returned to MAXON Lift must be pre-approved for return, and have the R.M.A. number written on the outside of the package in plain view, and returned freight prepaid. All returns are subject to a 15% handling charge if not accompanied by a detailed packing list. Returned parts are subject to no credit and returned back to the customer. Defective parts requested for return must be returned within 30 days of the claim date for consideration to:

MAXON Lift Corp.
10321 Greenleaf Ave., Santa Fe Springs, CA 90670
Attn: RMA# _____

MAXON's warranty policy does not include the reimbursement for travel time, towing, vehicle rental, service calls, oil, batteries or loss of income due to downtime. Fabrication or use of non Maxon parts, which are available from MAXON, are also not covered.

MAXON's Flat Rate Labor Schedule takes into consideration the time required for diagnosis of a problem.

All Liftgates returned are subject to inspection and a 15% restocking fee. Any returned Liftgates or components that have been installed or not returned in new condition will be subject to an additional reworking charge, which will be based upon the labor and material cost required to return the Liftgate or component to new condition.

PURCHASE PART WARRANTY

Term of Warranty: 1 Year from Date of Purchase.

Type of Warranty: Part replacement only. MAXON will guarantee all returned genuine MAXON replacement parts upon receipt and inspection of parts and original invoice.

All warranty replacements parts will be sent out via ground freight. If a rush shipment is requested, all freight charges will be billed to the requesting party.

TABLE OF CONTENTS

SUMMARY OF CHANGES: M-16-15, REVISION B.....	7
WARNINGS.....	8
PERIODIC MAINTENANCE.....	10
DECALS - WELDING CAUTION	10
DECALS	11
PREVENTATIVE MAINTENANCE CHECKLIST	13
PERIODIC MAINTENANCE CHECKS	15
BMR-CS LUBRICATION DIAGRAM.....	16
CHECKING HYDRAULIC FLUID	17
CHANGING HYDRAULIC FLUID	19
BLEEDING HYDRAULIC SYSTEM.....	20
ADJUSTMENT.....	21
CHECK & ADJUST CLEARANCE OF RUNNER PADS.....	21
PLATFORM CHAIN ADJUSTMENT	26
REPLACING PARTS	27
CLOSING CYLINDER REPLACEMENT	27
LIFTING CYLINDER REPLACEMENT	29
RUNNER REPLACEMENT	33
HYDRAULIC SYSTEM DIAGRAMS.....	52
PUMP & MOTOR SOLENOID OPERATION - GRAVITY DOWN.....	52
PUMP & MOTOR SOLENOID OPERATION - POWER DOWN.....	53
ELECTRICAL CONTROLLER DIAGRAMS	54
CONTROLLER INDICATIONS.....	54
CONTROLLER INPUT LED(S) NOT ILLUMINATED & OUTPUT LED(S) NOT ILLUMINATED	58

CONTROLLER INPUT LED(S) ILLUMINATED, BUT OUTPUT LED(S) NOT ILLUMINATED	59
CONTROLLER INPUT LED(S) & OUTPUT LED(S) ILLUMINATED, BUT LOSS OF LIFT-GATE FUNCTION	60
GRAVITY DOWN HYDRAULIC SCHEMATIC	61
GRAVITY DOWN HYDRAULIC LINES IDENTIFICATION	63
POWER DOWN HYDRAULIC SCHEMATIC	66
POWER DOWN HYDRAULIC LINES IDENTIFICATION	67
ELECTRICAL SYSTEM DIAGRAMS	69
INTERCONNECTING ELECTRICAL SCHEMATIC - GRAVITY DOWN	69
GRAVITY DOWN SINGLE & DUAL PUMP ELECTRICAL SCHEMATIC	70
INTERCONNECTING ELECTRICAL SCHEMATIC - POWER DOWN	71
POWER DOWN SINGLE & DUAL PUMP ELECTRICAL SCHEMATIC	72
WIRING HARNESS TWIST-LOCK CONNECTORS	73
BMR-CS ELECTRICAL VALUES	74
TROUBLESHOOTING	75
PLATFORM WILL NOT RAISE & MOTOR WILL NOT RUN (MTE PUMP)	75
PLATFORM WILL NOT RAISE & MOTOR WILL NOT RUN (BUCHER PUMP)	76
PLATFORM WILL NOT RAISE & MOTOR RUNS (MTE PUMP)	77
PLATFORM WILL NOT RAISE & MOTOR RUNS (BUCHER PUMP)	79
PLATFORM WILL NOT RAISE LOAD AT RATED CAPACITY (MTE PUMP)	81
PLATFORM WILL NOT RAISE LOAD AT RATED CAPACITY	82
(BUCHER PUMP)	82
PLATFORM RAISES AND LOWERS UNEVENLY	83
PLATFORM RAISES HALFWAY & STOPS (MTE PUMP)	85

PLATFORM RAISES HALFWAY & STOPS (BUCHER PUMP).....	87
PLATFORM WILL NOT FOLD (MTE PUMP)	89
PLATFORM WILL NOT FOLD (BUCHER PUMP).....	91
PLATFORM WILL NOT UNFOLD (MTE PUMP)	93
PLATFORM WILL NOT UNFOLD (BUCHER PUMP).....	95
POWER OPEN/CLOSE RELIEF VALVE PRESSURE SETTING (MTE PUMP).....	97
POWER OPEN/CLOSE RELIEF VALVE PRESSURE SETTING	98
(BUCHER PUMP).....	98
LIFTING LINE RELIEF VALVE PRESSURE SETTING (MTE PUMP)	99
LIFTING LINE RELIEF VALVE PRESSURE SETTING (BUCHER PUMP).....	100
TROUBLESHOOTING - GRAVITY DOWN.....	101
PLATFORM WILL NOT LOWER (MTE PUMP).....	101
PLATFORM WILL NOT LOWER (BUCHER PUMP)	103
PLATFORM LOWERS SLOWLY (MTE PUMP).....	105
PLATFORM LOWERS SLOWLY (BUCHER PUMP).....	107
TROUBLESHOOTING - POWER DOWN.....	109
RELIEF VALVE PRESSURE SETTING (MTE PUMP).....	109
RELIEF VALVE PRESSURE SETTING (BUCHER PUMP)	110
PLATFORM WILL NOT LOWER (MTE PUMP).....	111
PLATFORM WILL NOT LOWER (BUCHER PUMP)	113
PLATFORM LOWERS SLOWLY (MTE PUMP).....	115
PLATFORM LOWERS SLOWLY (BUCHER PUMP).....	117

SUMMARY OF CHANGES: M-16-15, REVISION B.

PAGE	DESCRIPTION OF CHANGE
COVER	Updated REV. and date of release.
74	Updated coil resistance and ampere values for Bucher pump solenoid valves H, E, C & B. Removed coil pull-in values.

Comply with the following WARNINGS and SAFETY INSTRUCTIONS while maintaining Liftgates. See Operation Manual for operating safety requirements.

WARNING

- Do not stand, or allow obstructions, under the platform when lowering the Liftgate. **Be sure your feet are clear of the Liftgate.**
- Keep fingers, hands, arms, legs, and feet clear of moving Liftgate parts (and platform edges) when operating the Liftgate.
- Correctly stow platform when not in use. Extended platforms could create a hazard for people and vehicles passing by.
- Disconnect Liftgate power cable from battery before repairing or servicing Liftgate.
- Remove all rings, watches and jewelry before doing any electrical work.
- If it is necessary to stand on the platform while maintaining the Liftgate, keep your feet and any objects clear of the inboard edge of the platform. Your feet or objects on the platform can become trapped between the platform and the Liftgate extension plate.
- Recommended practices for welding on steel parts are contained in the current **AWS (American Welding Society) D1.1 Structural Welding Code - Steel**. Damage to Liftgate and/or vehicle, and personal injury could result from welds that are done incorrectly.
- Recommended practices for welding on aluminum parts are contained in the current **AWS (American Welding Society) D1.2 Structural Welding Code - Aluminum**. Damage to Liftgate and/or vehicle, and personal injury could result from welds that are done incorrectly.
- Recommended practices for welding galvanized steel are contained in the current **AWS (American Welding Society) D19.0 Welding Zinc-Coated Steel**. Damage to Liftgate and/or vehicle, and personal injury can result from welds that are done incorrectly.

MAXON[®]

11921 Slauson Ave. Santa Fe Springs, CA. 90670 (800) 227-4116 FAX (888) 771-7713

SAFETY INSTRUCTIONS

- Read and understand the instructions in this **Maintenance Manual** before performing maintenance on the Liftgate.
- Before operating the Liftgate, read and understand the operating instructions in **Operation Manual**.
- Comply with all **WARNING** and instruction decals attached to the Liftgate.
- Keep decals clean and legible. If decals are illegible or missing, replace them. Free replacement decals are available from **Maxon Customer Service**.
- Consider the safety and location of bystanders and location of nearby objects when operating the Liftgate. Stand to one side of the platform while operating the Liftgate.
- Do not allow untrained persons or children to operate the Liftgate.
- Wear appropriate safety equipment such as protective eyeglasses, faceshield and clothing while performing maintenance on the Liftgate and handling the battery. Debris from drilling and contact with battery acid may injure unprotected eyes and skin.
- Be careful working by an automotive type battery. Make sure the work area is well ventilated and there are no flames or sparks near the battery. Never lay objects on the battery that can short the terminals together. If battery acid gets in your eyes, immediately seek first aid. If acid gets on your skin, immediately wash it off with soap and water.
- If an emergency situation arises (vehicle or Liftgate) while operating the Liftgate, release the control switch to stop the Liftgate.
- A correctly installed Liftgate operates smoothly and reasonably quiet. The only noticeable noise during operation comes from the power unit while the platform is raised. Listen for scraping, grating and binding noises and correct the problem before continuing to operate Liftgate.
- Use only **Maxon Authorized Parts** for replacement parts. Provide Liftgate model and serial number information with your parts order. Order replacement parts from:

MAXON LIFT CORP. Customer Service
11921 Slauson Ave., Santa Fe Springs, CA 90670

Online: www.maxonlift.com

Express Parts Ordering: Phone (800) 227-4116 ext. 4345

Email: Ask your Customer Service representative

PERIODIC MAINTENANCE DECALS - WELDING CAUTION

CAUTION

Comply with welding CAUTION decals on Liftgate runners.

NOTE: See following pages to find the other decals on Liftgate.

CAUTION

Electrical components and metal parts on this liftgate can be severely damaged by connecting an electric welder to liftgate at the wrong place. To prevent damage, always connect ground lead directly to the component being welded (e.g. runner, column, platform) and as close to the weld as possible.

P/N 260293

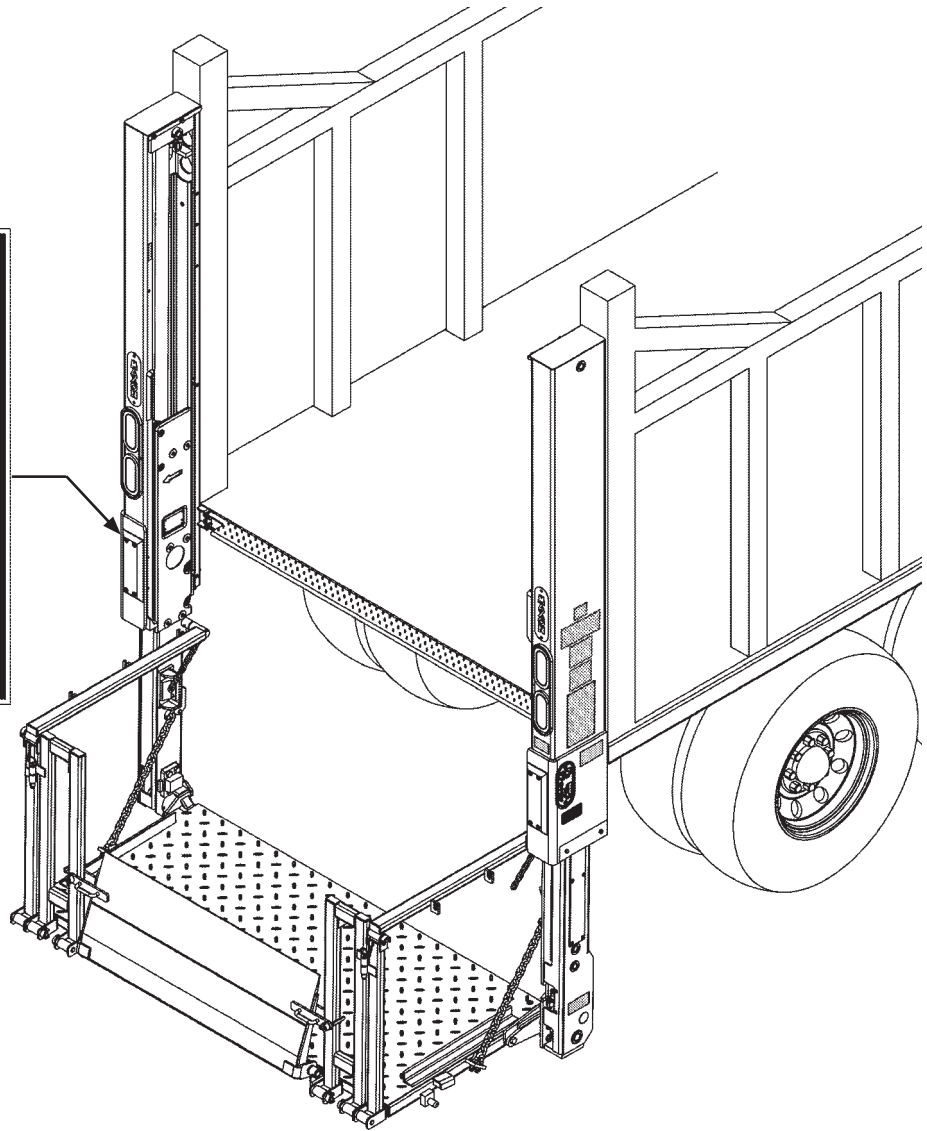

FIG. 10-1

MAXON[®]

11921 Slauson Ave. Santa Fe Springs, CA. 90670 (800) 227-4116 FAX (888) 771-7713

PERIODIC MAINTENANCE DECALS

NOTE: Ensure there is no residue, dirt, or corrosion where decals are attached. If necessary, clean surface before attaching decals.

NOTE: Decals on the Liftgate are attached at the factory.

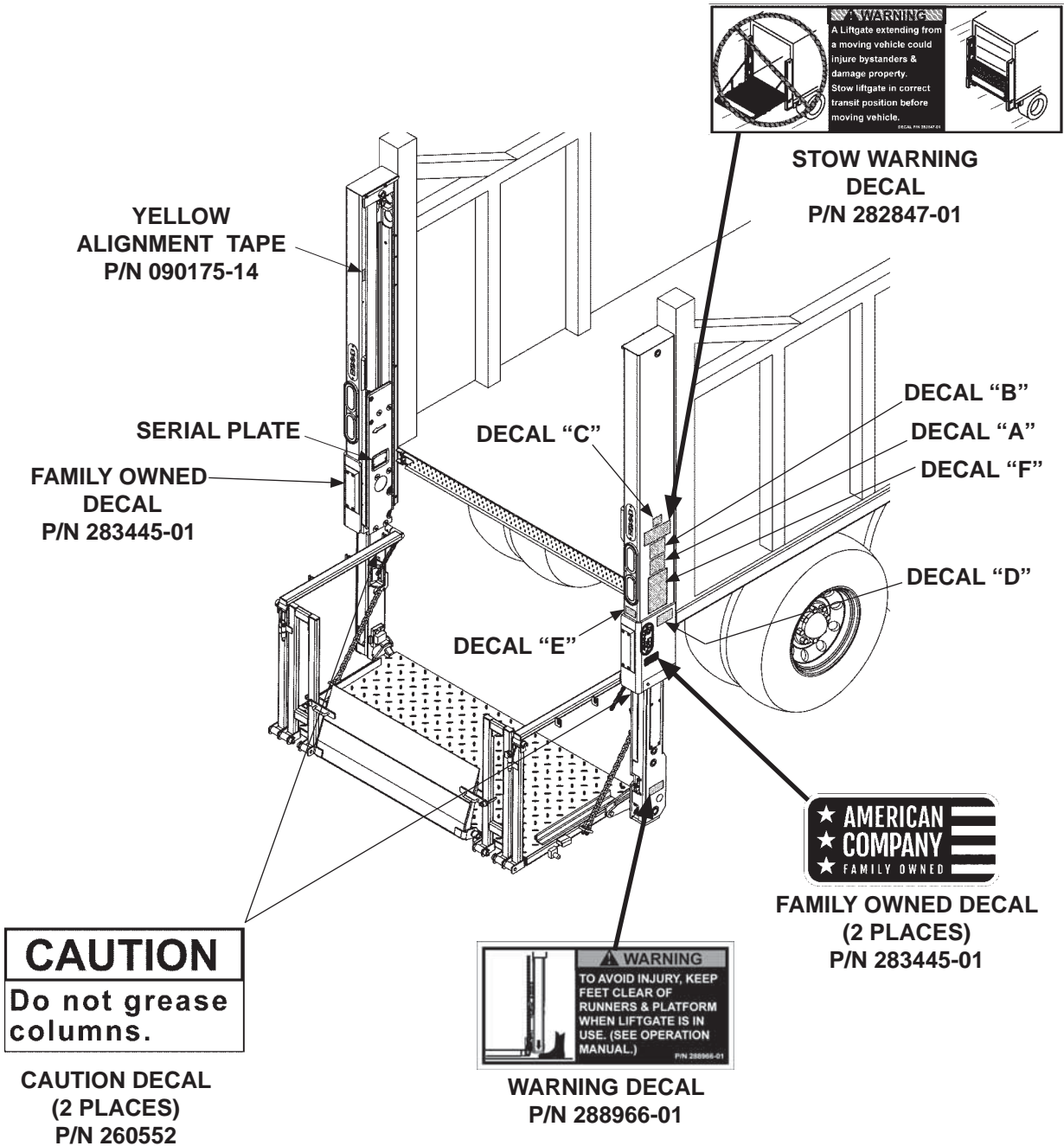

FIG. 11-1

WARNING
Read this information carefully.

- Improper operation of this Liftgate can result in serious personal injury. If you do not have a copy of the operating instructions, please obtain them from your employer, distributor, or lessor before you attempt to operate Liftgate.
- If there are signs of improper maintenance, damage to vital parts, or slippery platform surface, do not use the Liftgate until these problems have been corrected.
- If you are using a pallet jack, be sure it can be maneuvered safely.
- Do not operate a forklift on the platform.
- Do not allow any part of yours or your helper's body to be placed under, within, or around any portion of the moving Liftgate, or its mechanisms, or in a position that would trap them between the platform and the ground or truck when the Liftgate is operated.
- If a helper is riding the platform with you, make sure you are both doing so safely and that you are not in danger of coming in contact with any moving or potentially moving obstacles.
- **USE GOOD COMMON SENSE.**
- If load appears to be unsafe, do not lift or lower it.

For a free copy of other manuals that pertain to this model Liftgate, please visit our website at www.maxonlift.com or call Customer Service at (800) 227-4116. **(B)**

SAFETY INSTRUCTIONS
Read all decals and operation manual before operating liftgate.

1. Do not use liftgate unless you have been properly instructed and have read, and are familiar with, the operating instructions.
2. Be certain vehicle is properly and securely braked before using the liftgate.
3. Always inspect this liftgate for maintenance or damage before using it. Do not use liftgate if it shows any sign of damage or improper maintenance.
4. Do not overload
5. Make certain the area in which the platform will open and close is clear before opening or closing the platform.
6. Make certain platform area, including the area in which loads may fall from platform, is clear before and at all times during operation of liftgate.
7. This liftgate is intended for loading and unloading of cargo only. Do not use this liftgate for anything but its intended use. **(A)**

THE MAXIMUM CAPACITY OF THIS LIFT IS

___ LB [___ KG]

WHEN THE LOAD IS CENTERED ON THE LOAD CARRYING PLATFORM **(C)**

(REFER TO TABLE 12-1)

CAUTION
Always stand clear of platform area. **(E)**

WARNING
Liftgate hazards can result in crushing or falling.
Keep hands and feet clear of pinch points.
If riding liftgate, make sure load is stable and footing is solid. **(D)**

Read and understand all instructions and WARNINGS before use.

OPERATING INSTRUCTIONS

OPERATE	STOW
<p>1 LOWER RUNNERS TO LINE UP YELLOW ARROW WITH YELLOW STRIPE. THIS SHOWS PLATFORM IS CLEAR TO UNFOLD.</p>	<p>1 RAISE PLATFORM TO LINE UP YELLOW ARROW WITH YELLOW STRIPE. THIS SHOWS PLATFORM IS CLEAR TO FOLD.</p>
<p>2 UNFOLD PLATFORM.</p>	<p>2 FOLD PLATFORM.</p>
<p>3 1 - LOWER PLATFORM. IF IT IS SLOW TO LOWER & LIFTGATE IS POWER DOWN EQUIPPED, PUSH POWER DOWN BUTTON. 2 - RAISE PLATFORM. POWER DOWN BUTTON (IF EQUIPPED).</p>	<p>3 RAISE RUNNERS TO STOW PLATFORM.</p>

PIN 289163-01 **(F)**

DECAL SHEET FIG. 12-1

MODEL	ORDER P/N	DECAL "C"
BMR-CS35	289163-01	3500 LBS. [1600 KG]
BMR-CS44	289163-02	4400 LBS. [2000 KG]

DECAL SHEET PART NUMBERS TABLE 12-1

PERIODIC MAINTENANCE MAXON BMR-CS LIFTGATE PREVENTATIVE MAINTENANCE CHECKLIST

PM Interval: Quarterly / Annual

Date: ___ / ___ / ___

Equipment: _____

W/O # _____

Location: _____

Mechanic: _____

Serial # _____

Model # _____

Check Appropriate Box. "☐"

MAXON Quarterly Liftgate PM Procedures			
Satisfactory	Repair Required	Corrected	1 Check your company's maintenance records to verify when quarterly and annual PM's are due.
Satisfactory	Repair Required	Corrected	2 Check for oil leaks: cylinders, fittings, hoses, valves, oil filter and fittings inside of pump box.
Satisfactory	Repair Required	Corrected	3 Check for damage: bent ramps, platform, columns, runners & hydraulic tubes.
Satisfactory	Repair Required	Corrected	4 Check for loose or missing nuts, bolts, covers, roll pins, screws and pins.
Satisfactory	Repair Required	Corrected	5 Check for cracked welds: columns, runners, platform, chain arms, pump box and door frame.
Satisfactory	Repair Required	Corrected	6 Check platform lowering speed: Range is 8-22 seconds with unloaded platform. Check "D" valves for proper operation.
Satisfactory	Repair Required	Corrected	7 Check platform pins and couplers. Check roller assemblies.
Satisfactory	Repair Required	Corrected	8 Check platform raising speed: Range is 9-21 seconds with unloaded platform.
Satisfactory	Repair Required	Corrected	9 Check open and close speed: Range is 4-7 seconds in either direction.
Satisfactory	Repair Required	Corrected	10 Check platform pins and couplers. Check roller assemblies on runners.
Satisfactory	Repair Required	Corrected	11 Check switches, circuit breaker & wiring connections on Liftgate as well as inside pump box. Also check that ground strap connections are tight.
Satisfactory	Repair Required	Corrected	12 Check gear pump for unusual noise (i.e. squealing or excessive RPM).
Satisfactory	Repair Required	Corrected	13 Check oil level with platform stowed. Refer to oil decal inside pump cover. The sight glass should be half full. Check oil for contamination. Change if needed.
Satisfactory	Repair Required	Corrected	14 Check batteries: load test, corrosion, cables, hold downs and water level.
Satisfactory	Repair Required	Corrected	15 Check platform chains for wear each time maintenance is performed.
Satisfactory	Repair Required	Corrected	16 Check operation of retention ramps.
Satisfactory	Repair Required	Corrected	17 Check all charging and ground cable connections.
Satisfactory	Repair Required	Corrected	18 Pump EP synthetic grease in each lube fitting at 2 platform pivots and the 2 roller axles on the 4 tandems (if equipped with fittings). Wipe away grease seepage. Ensure each of the tandem rollers is clean and free of grease.
Satisfactory	Repair Required	Corrected	19 Follow your company's guidelines for completing PM stickers and maintenance records for the Liftgate.
MAXON Annual Liftgate PM Procedures			
Satisfactory	Repair Required	Corrected	20 Replace spin-on filter in pump box. Change hydraulic fluid if contaminated.
Satisfactory	Repair Required	Corrected	21 Inspect wear on slide pads, on the RH and LH runners.

For more detailed information, please refer to the applicable sections in this Maintenance Manual and the separate Parts Manual. Use only genuine Maxon replacement parts for all repairs.

MAXON 11921 Slauson Ave. Santa Fe Springs, CA. 90670 (800) 227-4116 FAX (888) 771-7713

MAXON[®]

11921 Slauson Ave. Santa Fe Springs, CA. 90670 (800) 227-4116 FAX (888) 771-7713

THIS PAGE INTENTIONALLY LEFT BLANK.

PERIODIC MAINTENANCE CHECKS

WARNING

Never operate the Liftgate if parts are loose or missing.

NOTE: Photocopy the **PM CHECKLIST** on the preceding page to help keep track of periodic maintenance on the Liftgate. Keep completed form with maintenance records.

NOTE: When replacing parts, refer to the Parts Portal on the Maxon website for genuine MAXON replacement parts.

Annually

- Change spin-on oil filter.
- Inspect for wear on slide pads on the RH & LH runners.

Quarterly

Check the hydraulic fluid level in the pump reservoir. Refer to the **CHECKING HYDRAULIC FLUID** procedure in the **PERIODIC MAINTENANCE** section.

- If hydraulic fluid appears contaminated, refer to the **CHANGING HYDRAULIC FLUID** procedure on following page.
- Keep track of the grade of hydraulic fluid in the pump reservoir. Never mix two different grades of fluid.
- Check pump box cover seal. Replace seal if damaged.
- Check hoses and fittings for chaffing and fluid leaks. Replace if necessary.
- Check electrical wiring for chaffing and make sure wiring connections are tight and free of corrosion. **MAXON** recommends using dielectric grease on all electrical connections.
- Check that all **WARNING** and **instruction decals** are in place and legible.
- Check that all roll pins are in place and protrude evenly from both sides of hinge pin collar. Replace roll pins if necessary.
- Check each end of the two platform chains to make sure they are fastened properly.
- Check for worn out links on each of the two platform chains.
- Pump EP synthetic grease in fitting on 2 platform pivots and roller axels on 4 tandems.
- Check for rust and oily surfaces on Liftgate. If there is rust or oil on the Liftgate, clean it off. Touch up the paint where bare metal is showing.

BMR-CS LUBRICATION DIAGRAM

NOTE: Lube fittings are shown for the tandem roller axles on the LH runner and the pivot on the LH side of platform. There are also lube fittings in the same location on the tandem roller axles for the RH runner and the pivot on the RH side of the platform. Refer to the **PERIODIC MAINTENANCE CHECKS** and **PREVENTATIVE MAINTENANCE CHECKLIST** for the recommended grease and maintenance interval.

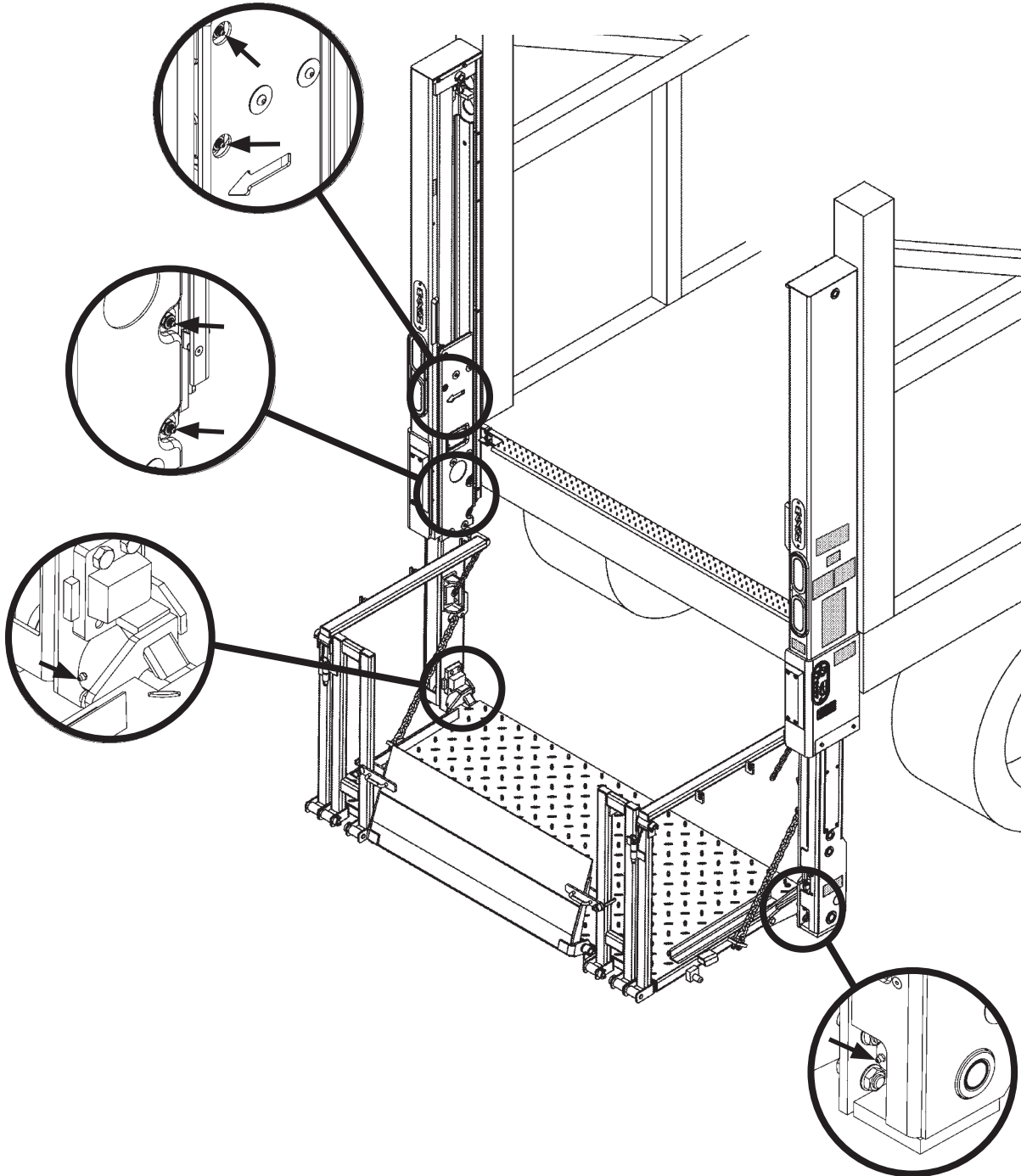

FIG. 16-1

PERIODIC MAINTENANCE

CHECKING HYDRAULIC FLUID

CAUTION

Keep dirt, water and other contaminants from entering the hydraulic system. Before opening the hydraulic fluid reservoir filler cap, drain plug and hydraulic lines, clean up contaminants that can get in the openings. Also, protect the openings from accidental contamination. Never mix synthetic fluids with conventional hydraulic fluids. Hydraulic system must be purged if the fluids are mixed.

NOTE: Exxon Unavis HVI-13 hydraulic fluid is recommended for operating temperatures of -40 to $+120^{\circ}$ F. Refer to decal in pump box. The ISO-15 fluids in TABLE 19-1 may be used if the recommended fluids are unavailable. If necessary, the ISO-32 fluids in TABLE 19-2 may be used where ordinary seasonal temperatures are near $+100^{\circ}$ F or higher.

NOTE: If the hydraulic fluid in the reservoir is contaminated, do the **CHANGING HYDRAULIC FLUID** procedure in this section.

1. Stow the platform in the up position. Refer to **Operation Manual** for instructions.
2. Open the pump box cover to gain access to pump reservoir (**FIG. 17-1**).

NOTE: Information for checking hydraulic fluid level is shown on a decal on the pump reservoir.

3. Check if hydraulic fluid level is at the full line (**FIG. 17-1**). If necessary, remove filler cap (**FIG. 17-1**) and add the correct grade of hydraulic fluid until level rises to the full line (**FIG. 17-1**).
4. Reinstall filler cap (**FIG. 17-1**) and close the pump box cover.

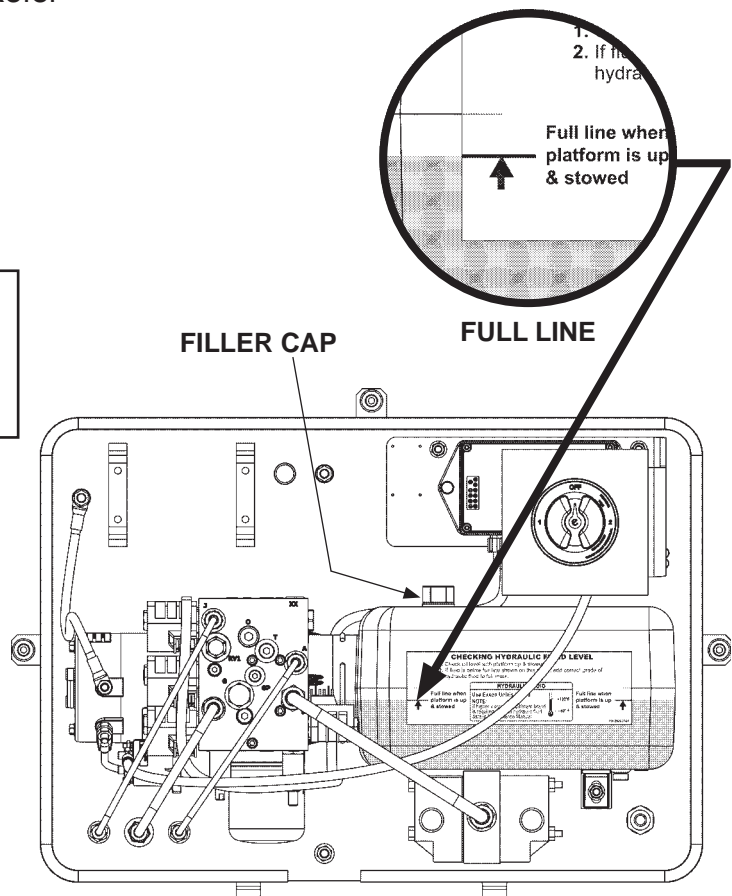

CHECKING HYDRAULIC FLUID LEVEL
FIG. 17-1

ISO-15 OR MIL-H-5606 TYPE HYDRAULIC OIL	
BRAND	PART NUMBER
CHEVRON	FLUID A, AW-MV-15
KENDALL	GLACIAL BLU
SHELL	TELLUS S2 VX 15
MOBIL	DTE-11M
ROSEMEAD	THS FLUID 17111

TABLE 18-1

ISO-32 HYDRAULIC OIL	
BRAND	PART NUMBER
CHEVRON	HIPERSYN 32
KENDALL	GOLDEN MV
SHELL	TELLUS S2 VX 32
EXXON	UNIVIS N-32
MOBIL	DTE-13M, DTE-24, HYDRAULIC OIL-13

TABLE 18-2

PERIODIC MAINTENANCE CHANGING HYDRAULIC FLUID

CAUTION

Keep dirt, water and other contaminants from entering the hydraulic system. Before opening the hydraulic fluid reservoir filler cap, drain plug and hydraulic lines, clean up contaminants that can get in the openings. Also, protect the openings from accidental contamination. Never mix synthetic fluids with conventional hydraulic fluids. Hydraulic system must be purged if the fluids are mixed.

NOTE: Exxon Univis HVI-13 hydraulic fluid is recommended for operating temperatures of -40 to $+120^{\circ}$ F. Refer to decal in pump box. The ISO-15 fluids in TABLE 19-1 may be used if the recommended fluids are unavailable. If necessary, the ISO-32 fluids in TABLE 19-2 may be used where ordinary seasonal temperatures are near $+100^{\circ}$ F or higher.

GRAVITY DOWN LIFTGATES

1. Place empty 5 gallon bucket under drain plug.
2. Open and lower platform. Remove the drain plug (FIG. 19-1). Drain hydraulic fluid from system. Reinstall drain plug.
3. Remove filler cap (FIG. 19-1). Refill reservoir until hydraulic fluid level until level rises to the full line (FIG. 19-1).
4. Reinstall filler cap (FIG. 19-1).

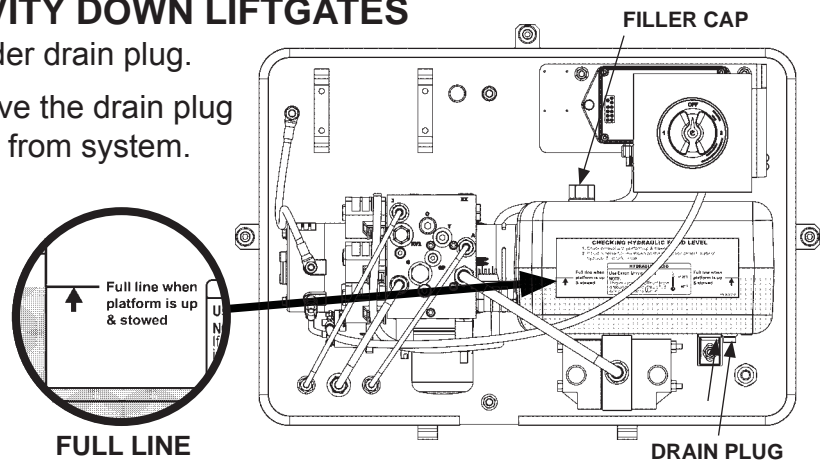

HYDRAULIC FLUID
FIG. 19-1

POWER DOWN LIFTGATES

1. Place empty 5 gallon bucket under drain plug.
2. If Liftgate is in power down mode, change to gravity down mode. Push the POWER DOWN ON DEMAND SWITCH so it is not illuminated. Refer to Operation Manual.
3. Open and lower platform. Remove the drain plug (FIG. 19-1). Drain hydraulic fluid from system. Reinstall drain plug.
4. Remove filler cap (FIG. 19-1). Refill reservoir until hydraulic fluid level until level rises to the full line (FIG. 19-1).
5. Reinstall filler cap (FIG. 19-1).

BLEEDING HYDRAULIC SYSTEM

NOTE: Perform this procedure at a place where Liftgate platform can be lowered to lowest point of travel. Get a helper to operate Liftgate control switch.

1. Use **UP/DOWN** toggle switch to lower the opened platform to the ground.
2. Loosen, but do not disconnect, the nut connecting hydraulic line to fitting on pressure compensated flow control valve (**FIG. 20-1**) at top of both cylinders.

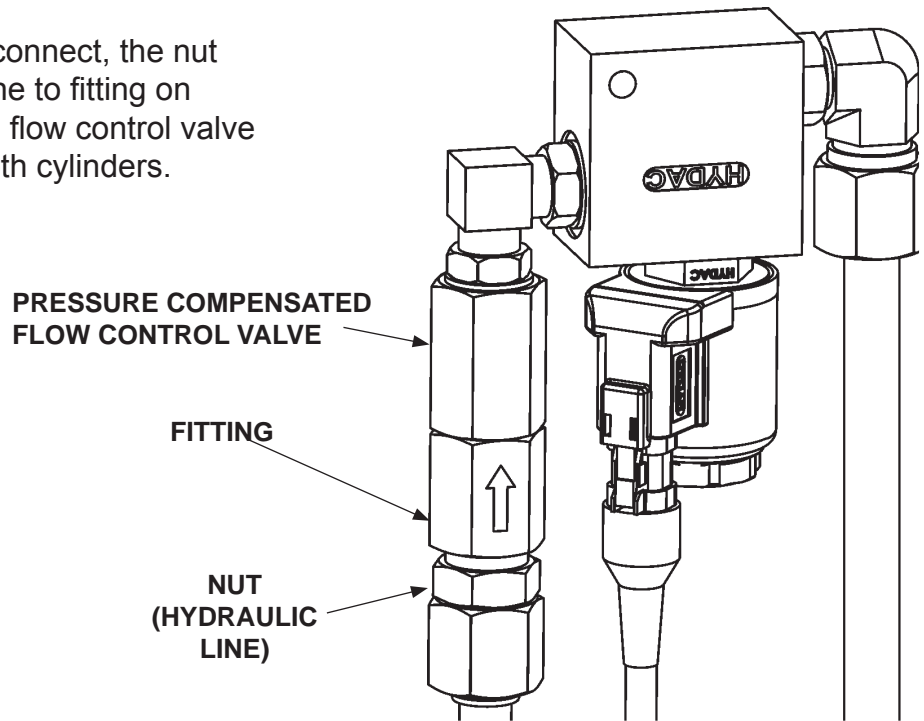

FIG. 20-1

3. Set the **UP/DOWN** switch on the RH runner in the **UP** position for approximately one second and then release the switch. Wait ten seconds and then switch to **UP** and release. Repeat this step until there is no air bubbling from the loosened line fittings.
4. Tighten nut on hydraulic line (**FIG. 20-1**).
5. Use **UP/DOWN** toggle switch to raise and lower the platform to make sure the Liftgate operates correctly.

ADJUSTMENT

CHECK & ADJUST CLEARANCE OF RUNNER PADS

NOTE: Perform the following steps with no load on the platform.

1. Raise the platform to bed height (**FIG. 21-1**). Then, lower the platform to the ground (**FIG. 21-2**). Look for the following conditions:

- Platform lowers smoothly.
- Platform lowers evenly on both sides.
- Platform lowers in **8 to 20 seconds** (**BMR-CS35/BMR-CS44**).

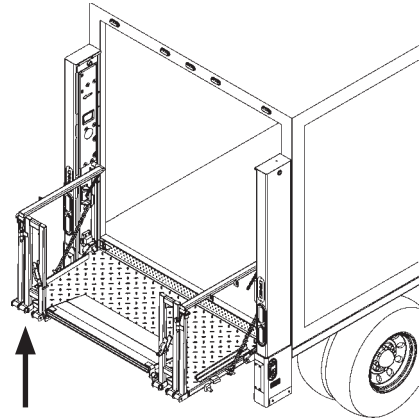

PLATFORM AT BED HEIGHT
FIG. 21-1

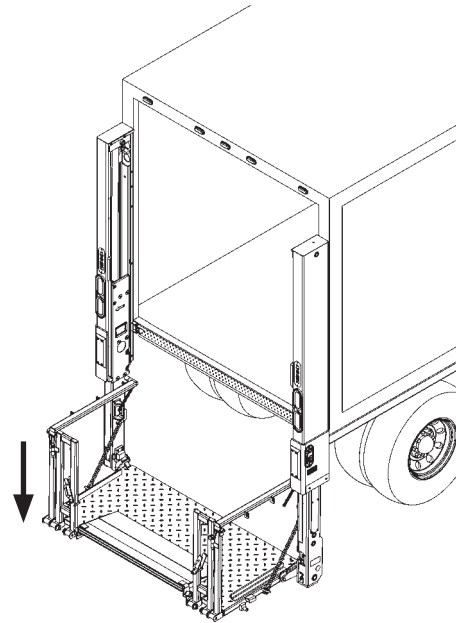

PLATFORM ON THE GROUND
FIG. 21-2

2. Raise the platform to bed height (**FIG. 22-1**). Check clearance of the runner pads as follows:

- Between upper runner pad and inner LH column.
- Between bottom runner pad and inner LH column.
- Between upper runner pad and inner RH column.
- Between bottom runner pad and inner RH column.

Sufficient clearance is equal to thickness of **2 business cards or .012" to .025"** measured with thickness gauge. Leaves of the thickness gauge should be 3" or longer to reach the runner pads.

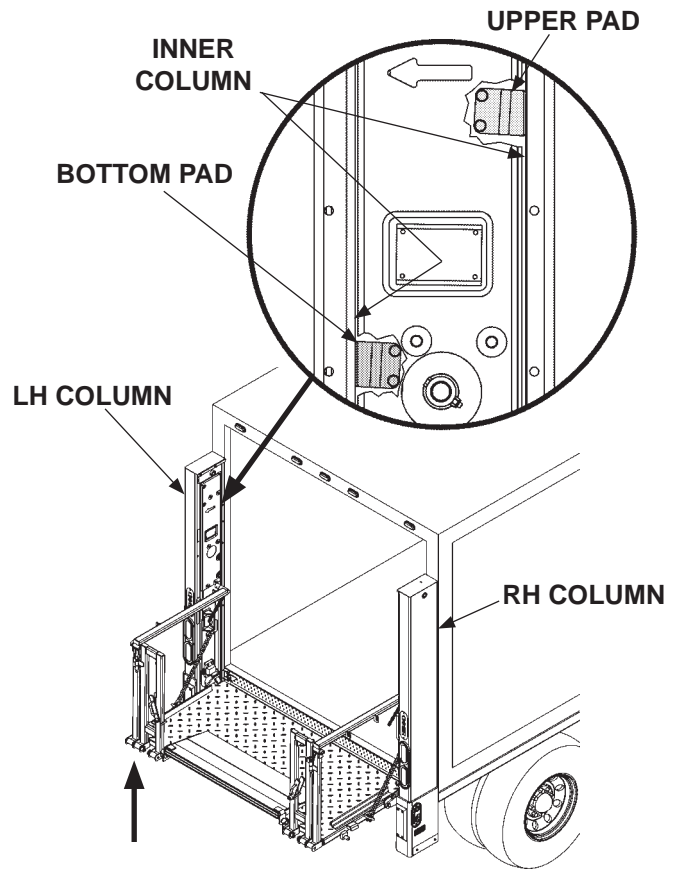

CHECKING CLEARANCE OF RUNNER PADS WITH PLATFORM AT BED HEIGHT
FIG. 22-1

3. Lower the platform half the distance to the ground (**FIG. 22-2**). Repeat the clearance checks in 2.

4. If there is no clearance or clearance is not sufficient, continue with adjustment procedure on the next page.

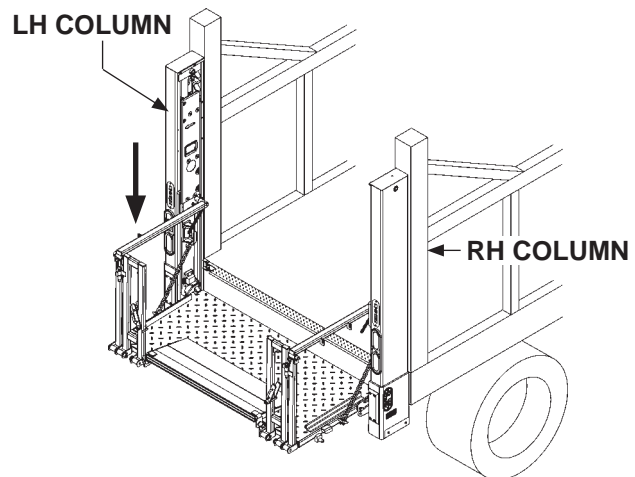

CHECKING CLEARANCE OF RUNNER PADS WITH PLATFORM BETWEEN BED HEIGHT & THE GROUND
FIG. 22-2

ADJUSTMENT

CHECK & ADJUST CLEARANCE OF RUNNER PADS - Continued

5. Remove LH runner cover (FIG. 23-1).

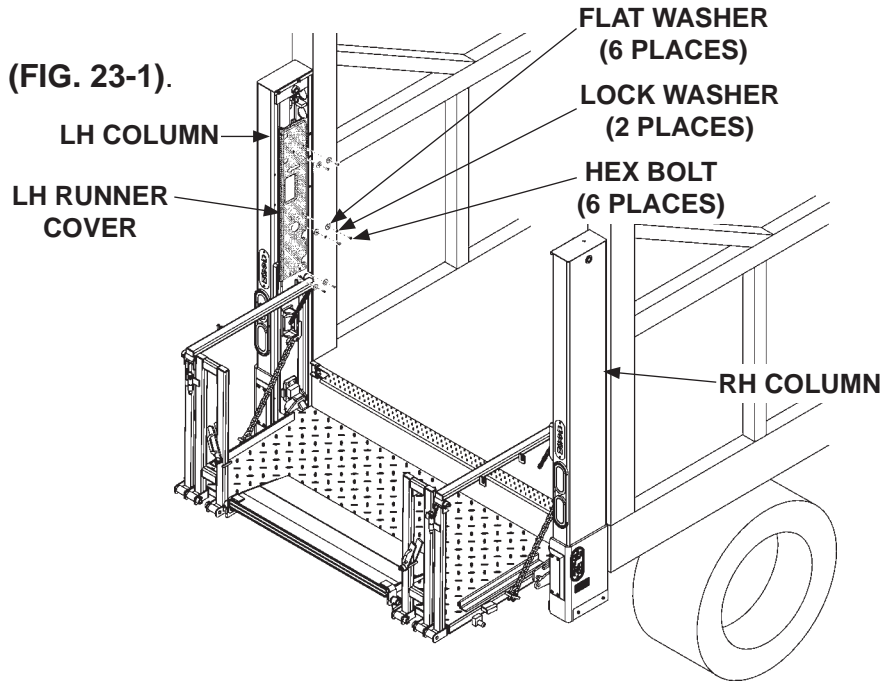

REMOVING RUNNER COVERS

FIG. 23-1

NOTE: Keep spacer pad in place between column & runner after unbolting pad from runner.

6. Unbolt bottom spacer pad from LH runner (FIG. 23-2). Keep bolts and lock washers to reinstall.

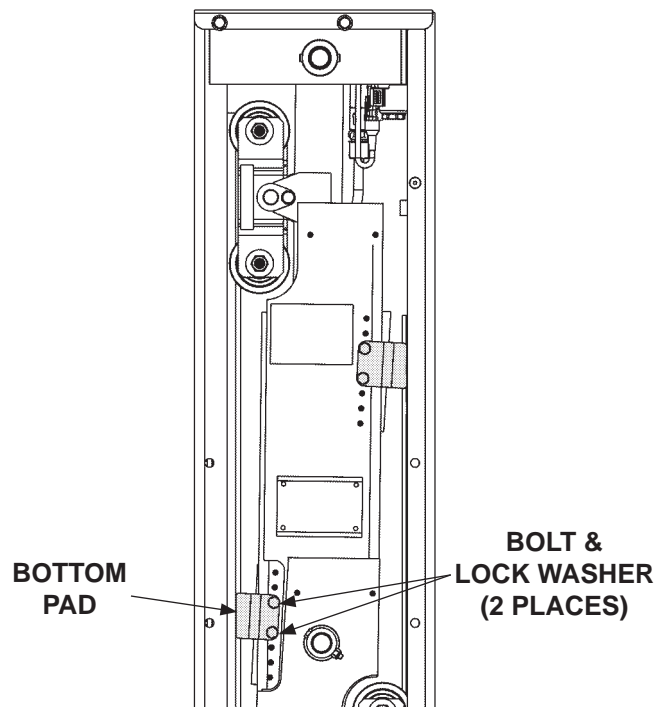

UNBOLTING PADS (LH COLUMN & RUNNER SHOWN)

FIG. 23-2

7. Ensure the bottom tandem rollers are seated against inner column (**FIG. 24-1**). Next, slide the bottom pad down against wedge until there is no clearance between inner column and bottom pad (**FIG. 24-1**). Then, back off (slide up) bottom pad by 1 hole position to create clearance between pad and inner column.

8. Bolt bottom pad to LH runner with 2 bolts and 2 lock washers (**FIG. 24-2**). Torque the 2 bolts to **9-14 lb.-ft.**

NOTE: Keep spacer pad in place between column & runner after unbolting pad from runner.

9. Unbolt upper spacer pad from LH runner (**FIG. 24-2**). Keep bolts & lock washers to reinstall.

10. Ensure upper tandem rollers are seated against inner column (**FIG. 24-2**). Next, slide the upper pad up against wedge until there is no clearance between inner column and upper pad (**FIG. 24-1**). Then, back off (slide down) lower pad by 1 hole position to create clearance between upper pad and inner column.

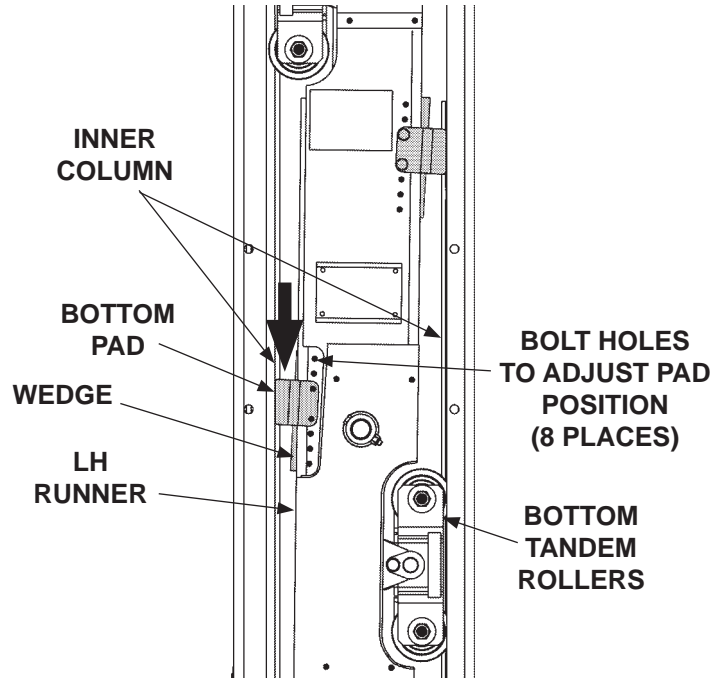

**ADJUSTING LOWER PAD
FIG. 24-1**

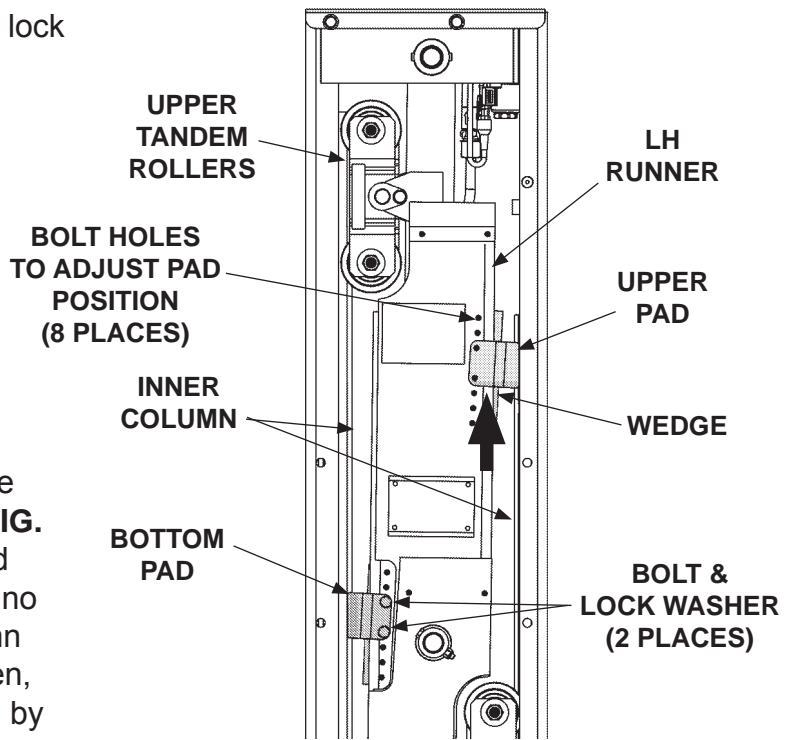

**BOLTING LOWER PAD &
ADJUSTING UPPER PAD
FIG. 24-2**

ADJUSTMENT

CHECK & ADJUST CLEARANCE OF RUNNER PADS - Continued

11. Bolt upper pad to LH runner with 2 bolts and 2 lock washers (**FIG. 25-1**). Torque the 2 bolts to **9-14 lb.-ft.**

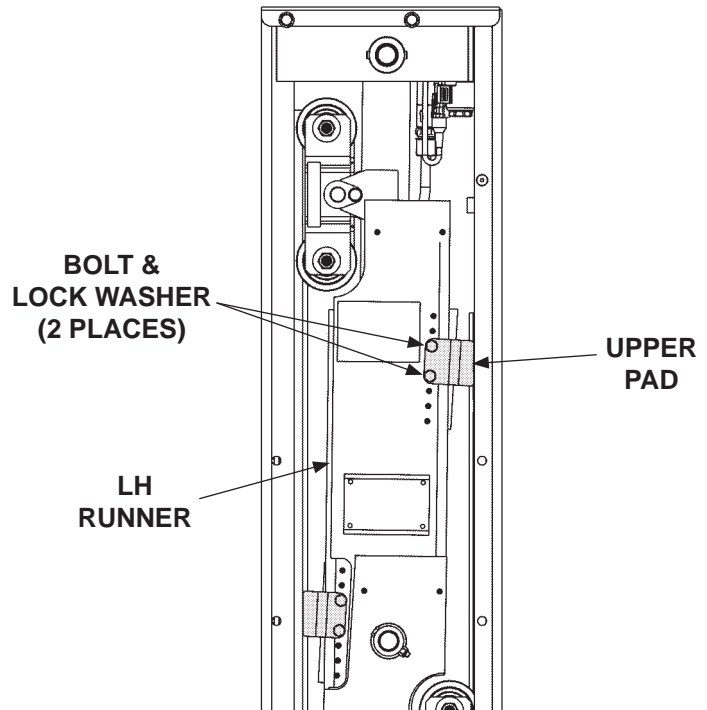

BOLTING UPPER PAD
FIG. 25-1

12. Repeat instructions 5 to 11 for RH column.

13. Raise the platform to bed height (**FIG. 25-2**). Then, lower the platform to the ground (**FIG. 25-2**). Look for the following conditions:

- Platform lowers smoothly.
- Platform lowers evenly on both sides.
- Platform lowers in **8 to 20 seconds** (**BMR-CS35/BMR-CS44**).

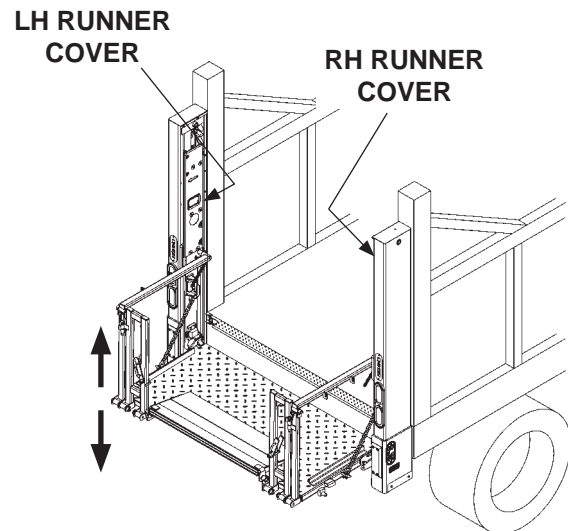

CHECKING CLEARANCE OF RUNNER PADS
WITH PLATFORM BETWEEN BED
HEIGHT & THE GROUND
FIG. 25-2

14. When platform raises and lowers correctly, reinstall LH and RH runner covers (**FIG. 25-2**). Torque 6 bolts on each runner cover to **9-14 lb.-ft.**

PLATFORM CHAIN ADJUSTMENT

1. Lower the platform to ground level. Check if tip of the platform and bottom of the runners touch the ground at the same time (**FIG. 26-1**).

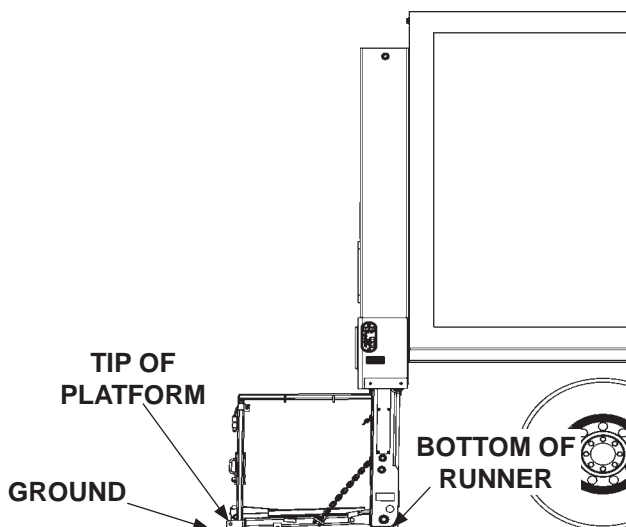

TIP AND RUNNER TOUCHING GROUND
FIG. 26-1

2. If tip of platform touches first, tighten the u-bolt by loosening the hex nuts and turning the lock nuts clockwise (**FIG.26-2A**). Retighten hex nuts. If more adjustment is required, remove one chain link until tip of the platform and bottom of the runners touch the ground at the same time (**FIG.26-2**).

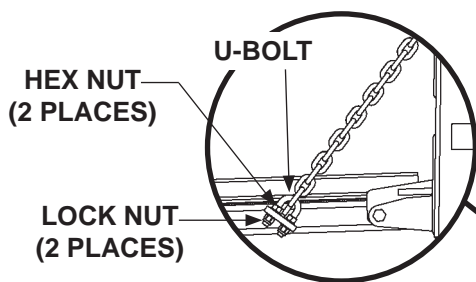
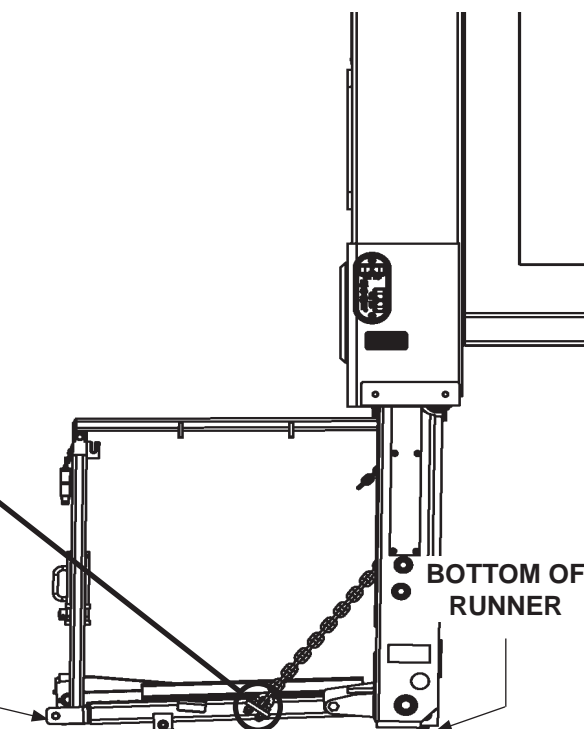

FIG. 26-2A

TIP OF PLATFORM



PLATFORM LOWERED TO GROUND
FIG. 26-2

MAXON[®]

11921 Slauson Ave. Santa Fe Springs, CA. 90670 (800) 227-4116 FAX (888) 771-7713

REPLACING PARTS CLOSING CYLINDER REPLACEMENT

1. **UNFOLD** the platform. Lower the platform (**DOWN**) to comfortable height for work. Upper pin must be lower than the bottom of the column (see **FIG. 27-1**).
2. Disconnect the hydraulic hoses from lower end of cylinder (**FIG. 27-2**). Plug hoses to prevent spills.
3. Remove the upper roll pin (**FIG. 27-2**) from the runner and then remove the upper pin.

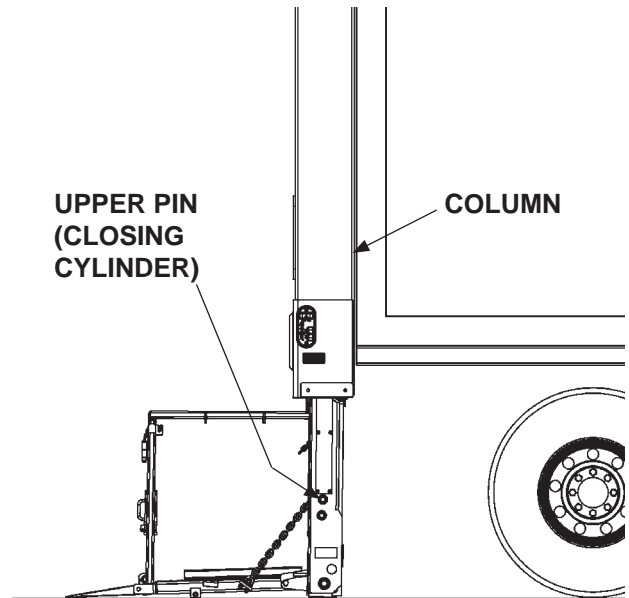

FIG. 27-1

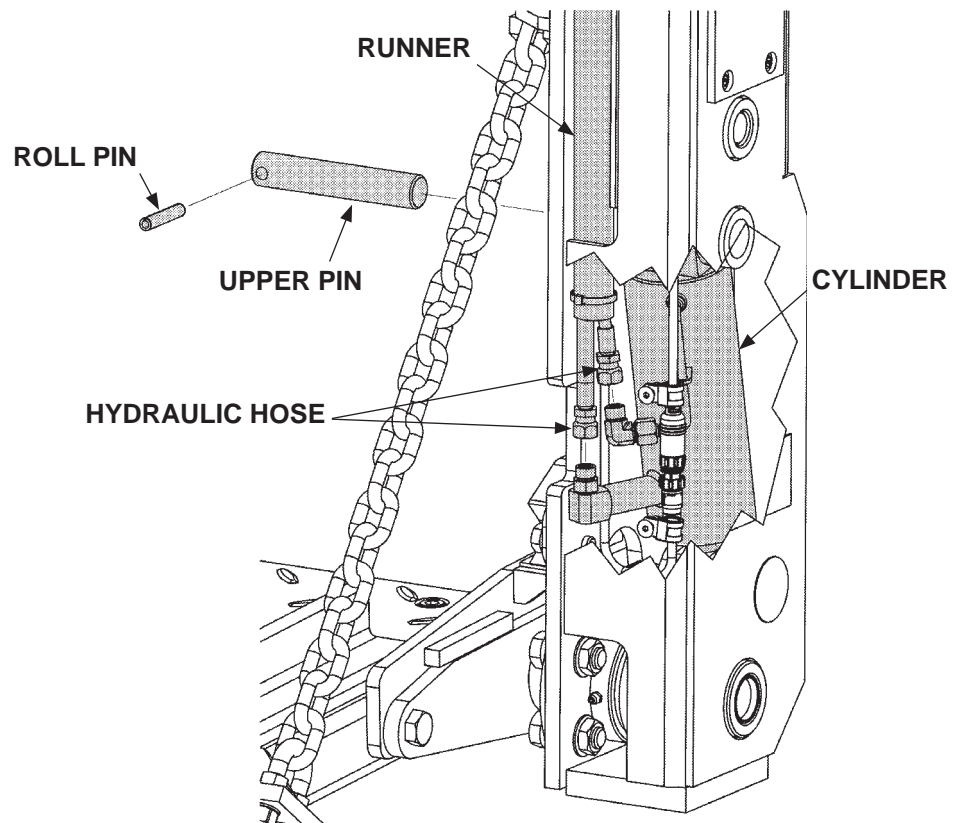
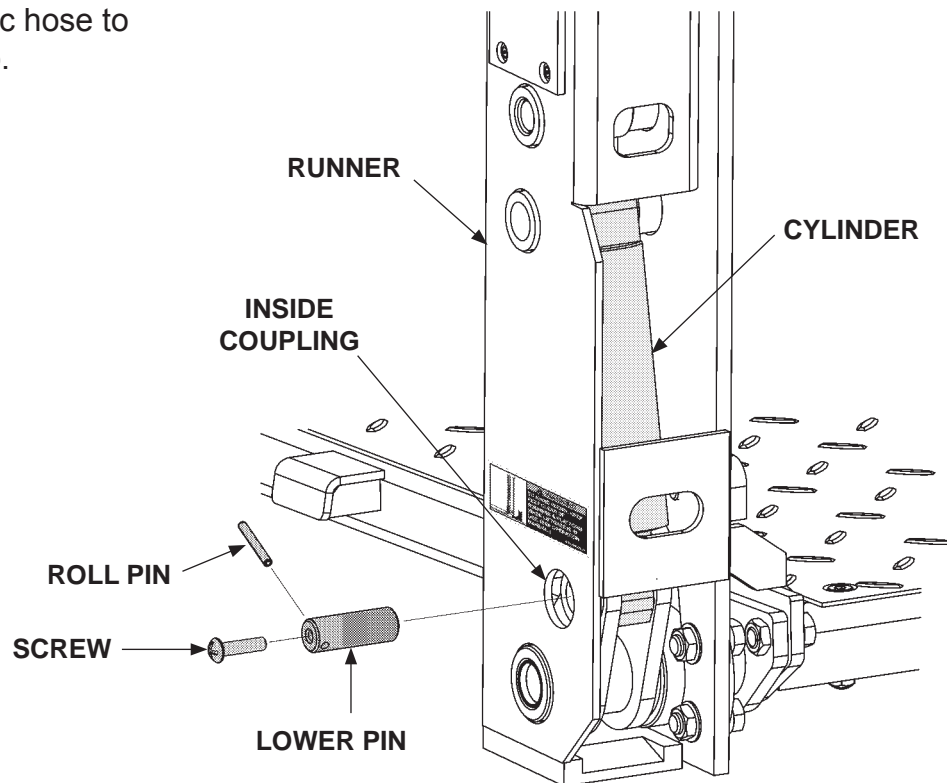

FIG. 27-2

4. Remove the lower pin plug and remove the lower roll pin from inside coupling (**FIG. 28-1**). Remove the lower pin by threading a 3/8" screw into the lower pin and pulling out on the pin. (**FIG. 28-1**).
5. Remove cylinder from runner (**FIG. 28-1**).
6. Place replacement cylinder in the correct position as shown in **FIG. 28-1**.
7. Install upper pin (**FIG. 28-2**) and roll pin in upper end of cylinder and runner.
8. Install lower pin (**FIG. 28-1**) and roll pin in lower end of cylinder and inside coupling. Replace plug.
9. Reconnect hydraulic hose to cylinder (**FIG. 28-2**).

**FIG. 28-1**

REPLACING PARTS

LIFTING CYLINDER REPLACEMENT

⚠ WARNING

Use floor jack and jack stands to support platform while performing this procedure.

CAUTION

Keep dirt, water and other contaminants from entering the hydraulic system. Before opening the hydraulic fluid reservoir filler cap, drain plug and hydraulic lines, clean up contaminants that can get in the openings. Also, protect the openings from accidental contamination.

NOTE: Refer to **Operation Manual** for instructions to operate Liftgate.

1. Raise the open platform about 20" above the ground. Then, place jack stands under the platform (**FIG. 29-1**) for support. Measure and record the distance between the centers of upper and lower cylinder pins. Keep measurement for reference when installing new cylinder.
2. Remove column cover (**FIG. 29-1A**). Then, put empty 3 gallon container under column for hydraulic fluid.

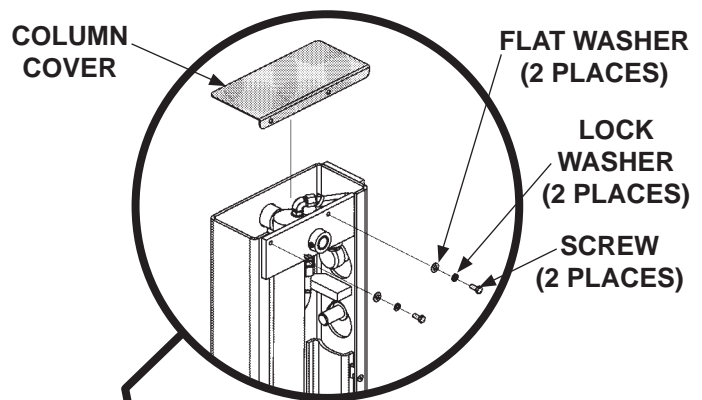

FIG. 29-1A

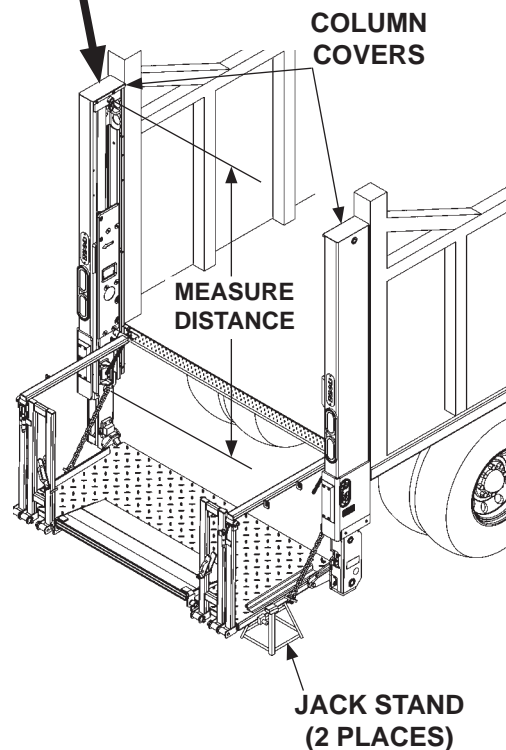
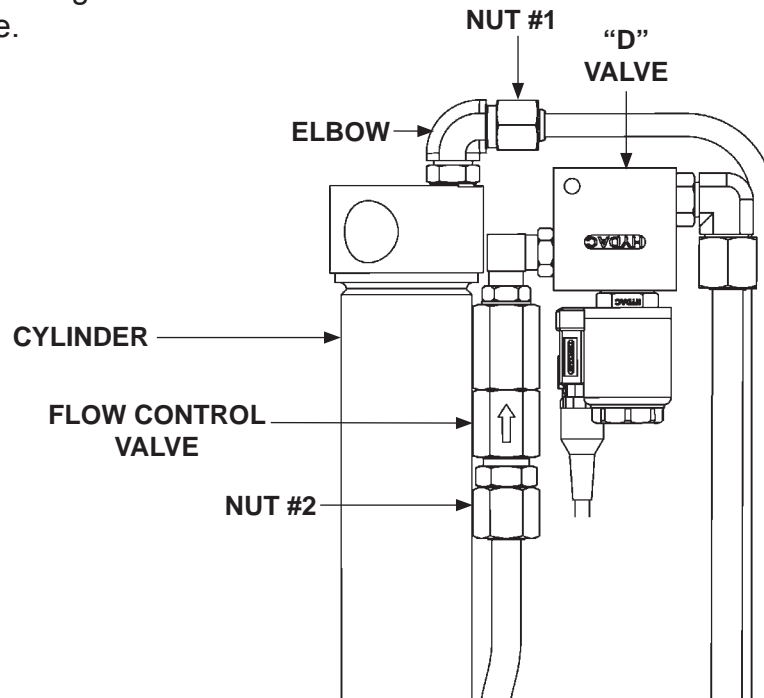

FIG. 29-1

3. Loosen and disengage nut #1 (**FIG. 30-1**) from elbow on top of cylinder. Remove elbow from cylinder (**FIG. 30-1**). Keep elbow to reinstall on new cylinder. Loosen and disengage nut #2 from fitting on bottom of flow control valve.

**FIG. 30-1**

REPLACING PARTS LIFTING CYLINDER REPLACEMENT - Continued

4. Remove lower roll pin & lower pin from lifting cylinder (**FIG. 31-1**). Then, clamp large, curved vise grip pliers around the cylinder just above the top of the runner as shown in **FIG. 31-1**.

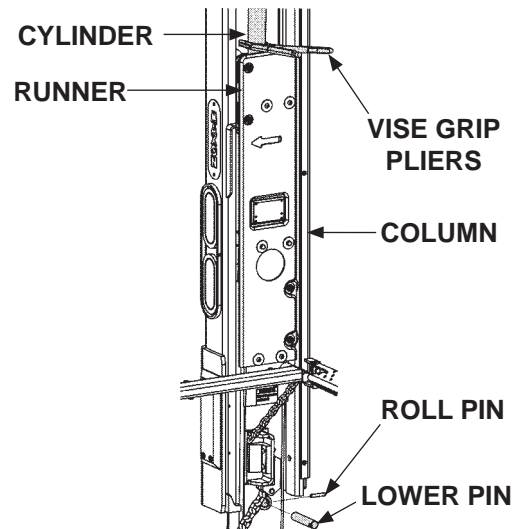

**SECURING CYLINDER
FIG. 31-1**

5. Remove upper roll pin & upper pin from cylinder (**FIG. 31-2**). Lift cylinder about 4" above top of column.

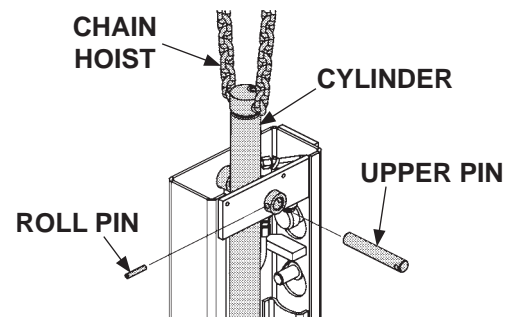

**REMOVING CYLINDER
FIG. 31-2**

6. Remove cylinder from column as follows. Attach a chain hoist or equivalent lifting device to support the upper end of cylinder (**FIG. 31-2**). Remove vise grip pliers from cylinder. Hoist the cylinder until it clears the top of column. Then lower cylinder to the ground.

! CAUTION
Move old cylinder out of the way to prevent possible trip hazard.

7. Remove plastic plugs from line fittings on new cylinder. Then fasten a long clean extension hose, with #8 face seal connector, to lifting line as shown in **FIG. 31-3**.

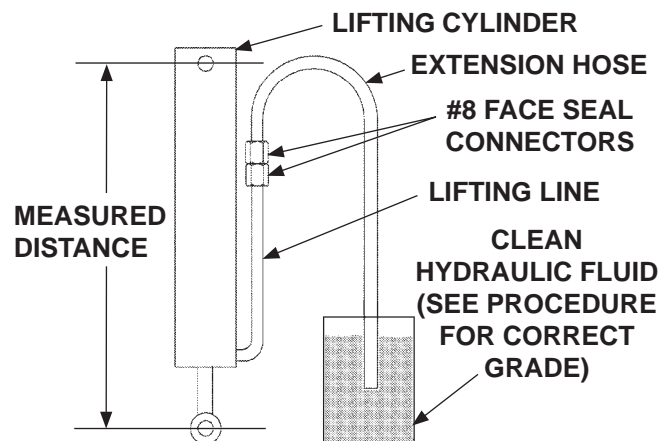

**PREPARING NEW CYLINDER
FOR INSTALLATION
FIG. 31-3**

8. Fully extend cylinder rod. Then place open end of hose in gallon container of clean hydraulic fluid. Next, push cylinder rod into cylinder until distance measured between butt-end and rod-end pin bores, is the same as distance recorded in **Step 1**. Replace plastic plug on top of cylinder housing.

9. To help remove air from rod end of housing, position cylinder on its side with the lifting line on top (**FIG. 32-1**). Then slowly return cylinder to vertical position (**FIG. 32-2**).

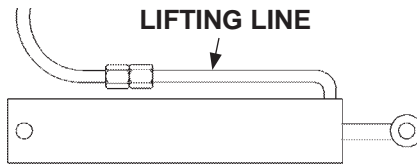

**CYLINDER POSITIONED ON SIDE
FIG. 32-1**

10. Remove extension hose and plug the lifting line (**FIG. 32-3**).

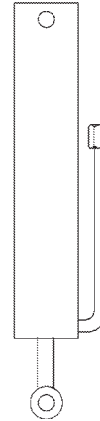

**CYLINDER WITH HOSE REMOVED
FIG. 32-2**

NOTE: Before installing a new cylinder, get a helper. Have the helper look through square inspection hole on back of runner while cylinder is lowered. The helper can inform installer when rod end of cylinder is lined up with lower pin.

NOTE: To install cylinder correctly, make sure hydraulic lines on cylinder are facing the vehicle body.

11. To install new Lifting cylinder, reverse **Steps 6, 5, 4, 3, and 2**.
12. Raise platform enough to remove jack stands (**FIG. 32-3**). Then lower platform all the way. Pressurize hydraulic system by pushing control switch to **UP** position. Release switch when platform is raised to bed height.
13. If necessary, do the **BLEEDING HYDRAULIC FLUID** procedure in this manual.

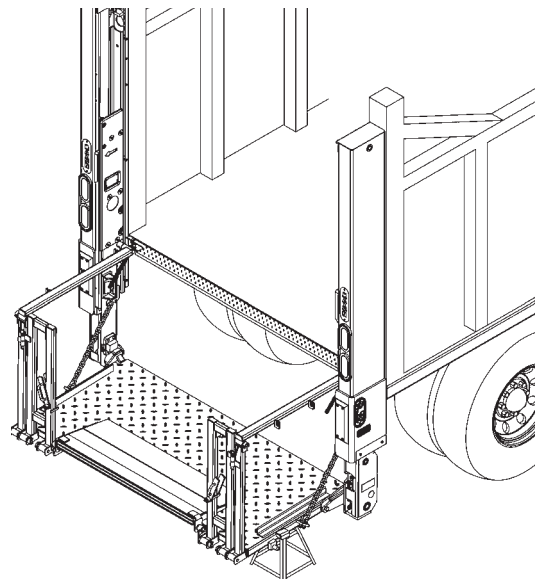

FIG. 32-3

REPLACING PARTS

RUNNER REPLACEMENT

NOTE: Refer to **Operation Manual** for instructions to operate Liftgate.

1. Lower the platform (**DOWN**) to approximately 12" above the ground. Support platform with 2 jack stands (**FIG. 33-1**). Make sure ramp edge is 4" higher than inboard edge of platform.

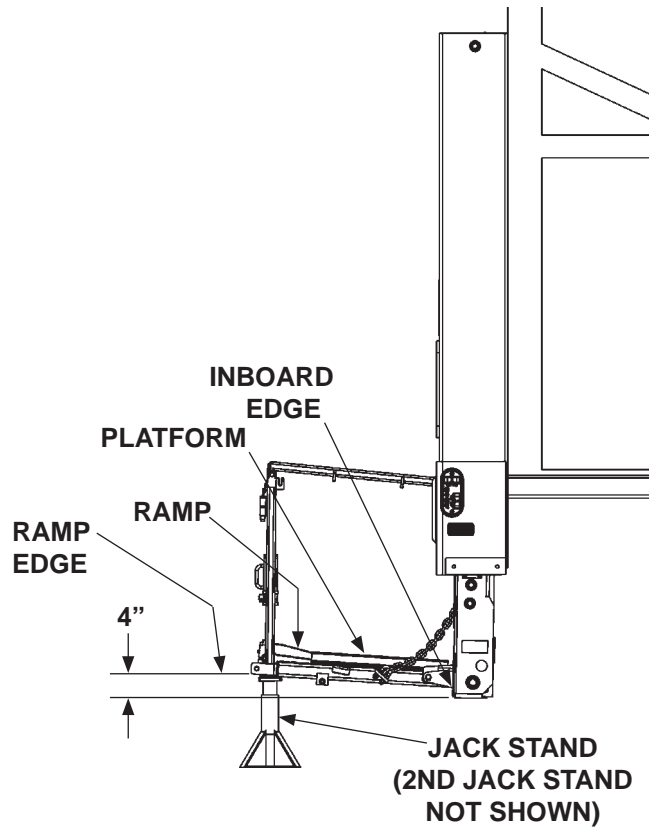

FIG. 33-1

2. Remove cotter pin and pin to remove chain bracket from LH runner (**FIG 33-2**). Next, remove roll pin and opener pin to remove platform railing from LH runner (**FIG 33-2**). Then, unbolt and remove cover from runner. Repeat for RH chain bracket, platform railing and RH runner.

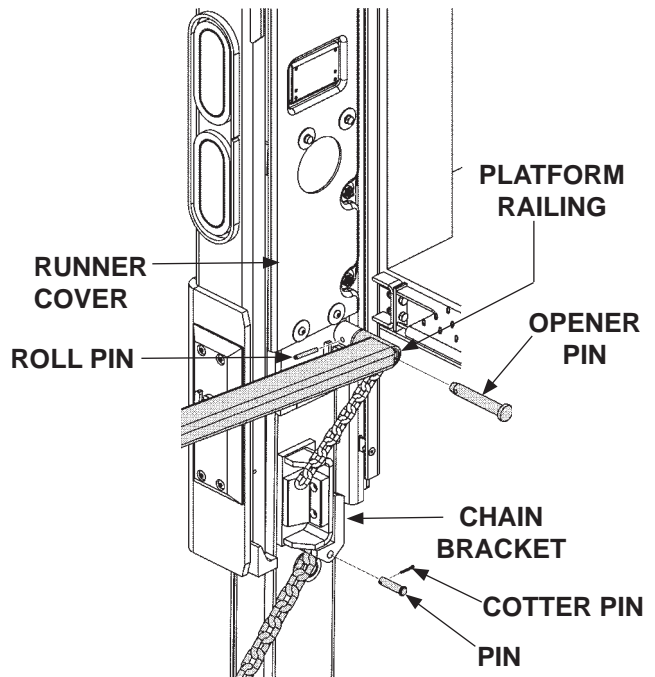

FIG. 33-2

- 3. Raise the platform (**UP**) slightly and place 2 more jack stands near the inboard edge (**FIG. 34-1**).

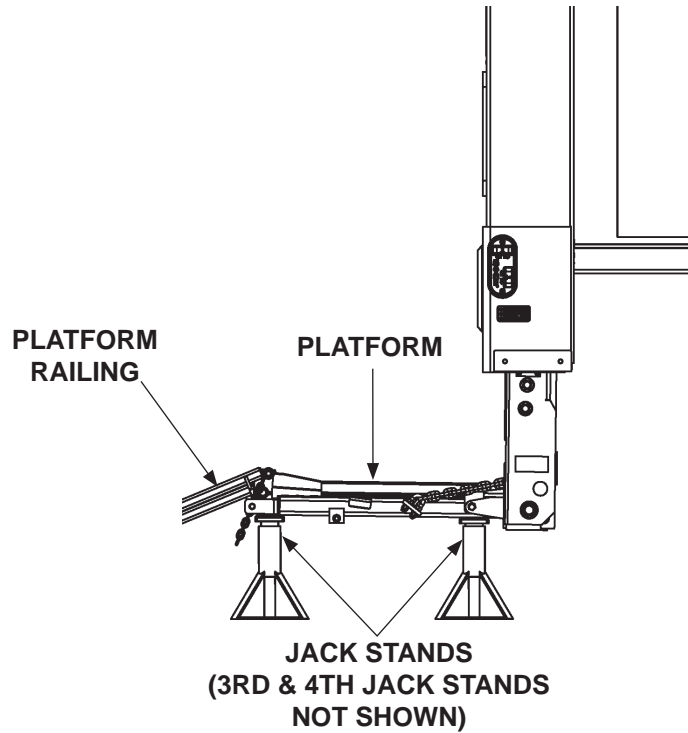

FIG. 34-1

- 4. Unbolt platform and connector bar from pin at the RH runner (**FIG. 34-2**). Then, remove pin. Repeat for LH runner.

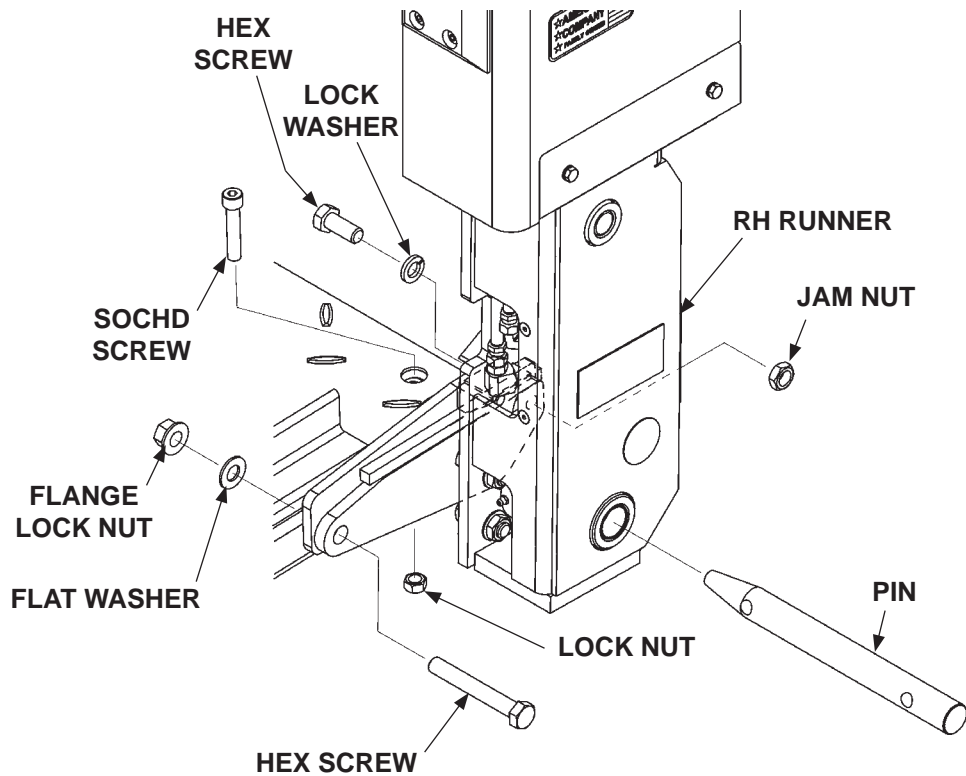

FIG. 34-2

REPLACING PARTS RUNNER REPLACEMENT - Continued

5. Use a forklift or equivalent lifting device to move the platform approximately 6" towards the front of the vehicle to clear the platform away from the attaching points on the runners (**FIG. 35-1**). When platform is clear of the runners, raise the runners (**UP**) a few inches. Then, move platform away from liftgate and the back of the vehicle.

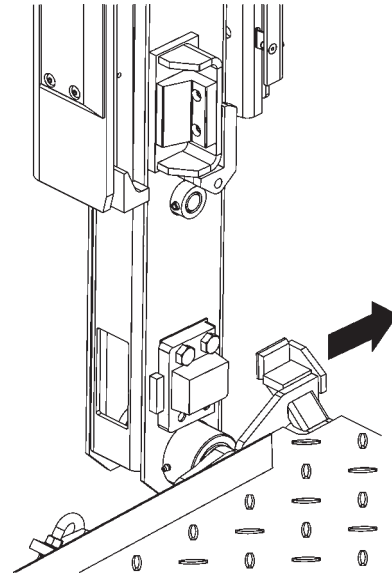

FIG. 35-1

6. Lower runners (**DOWN**) to the ground.

NOTE: If replacing LH runner, skip steps 7, 8, and 9.

7. Do the opening/closing cylinder removal steps in the **OPENING/CLOSING CYLINDER REPLACEMENT** procedure in this manual.
8. Disconnect runner switch cable from flexible cable near bottom of runner as shown in **FIG. 35-2**. Then, unfasten runner switch cable clamps from runner by removing lock nut (**FIG. 35-2**). Remove clamp from cable connector.
9. Pull flexible cable and twin hydraulic hoses away from the channel at bottom of runner (**FIG. 35-2**).

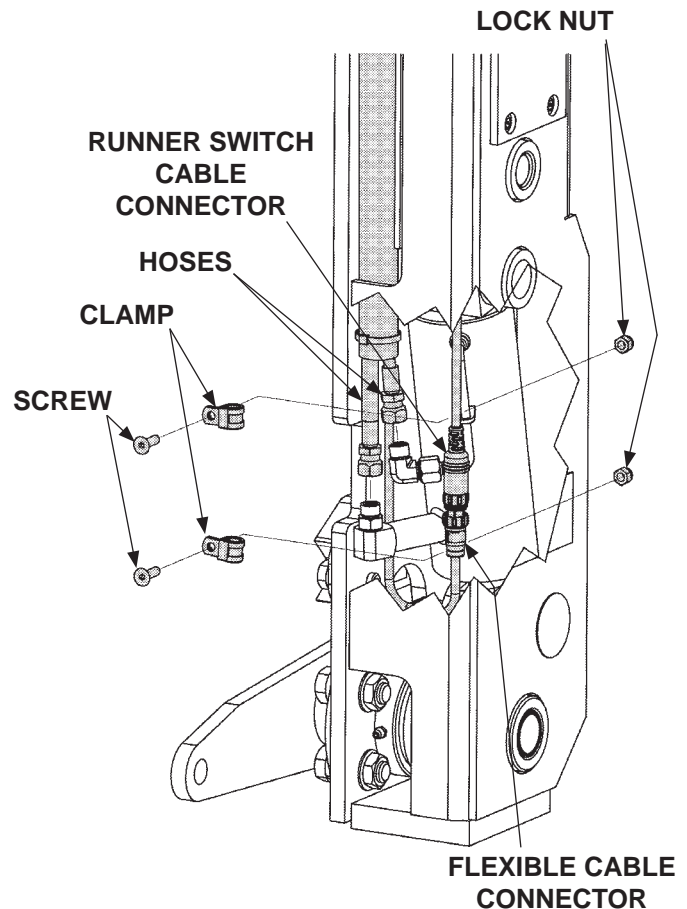

FIG. 35-2

10. Unbolt RH column cover from runner (**FIG. 36-1**).

11. Unbolt the upper and lower pad assemblies (**FIGS. 36-1A & 36-1B**) from runner.

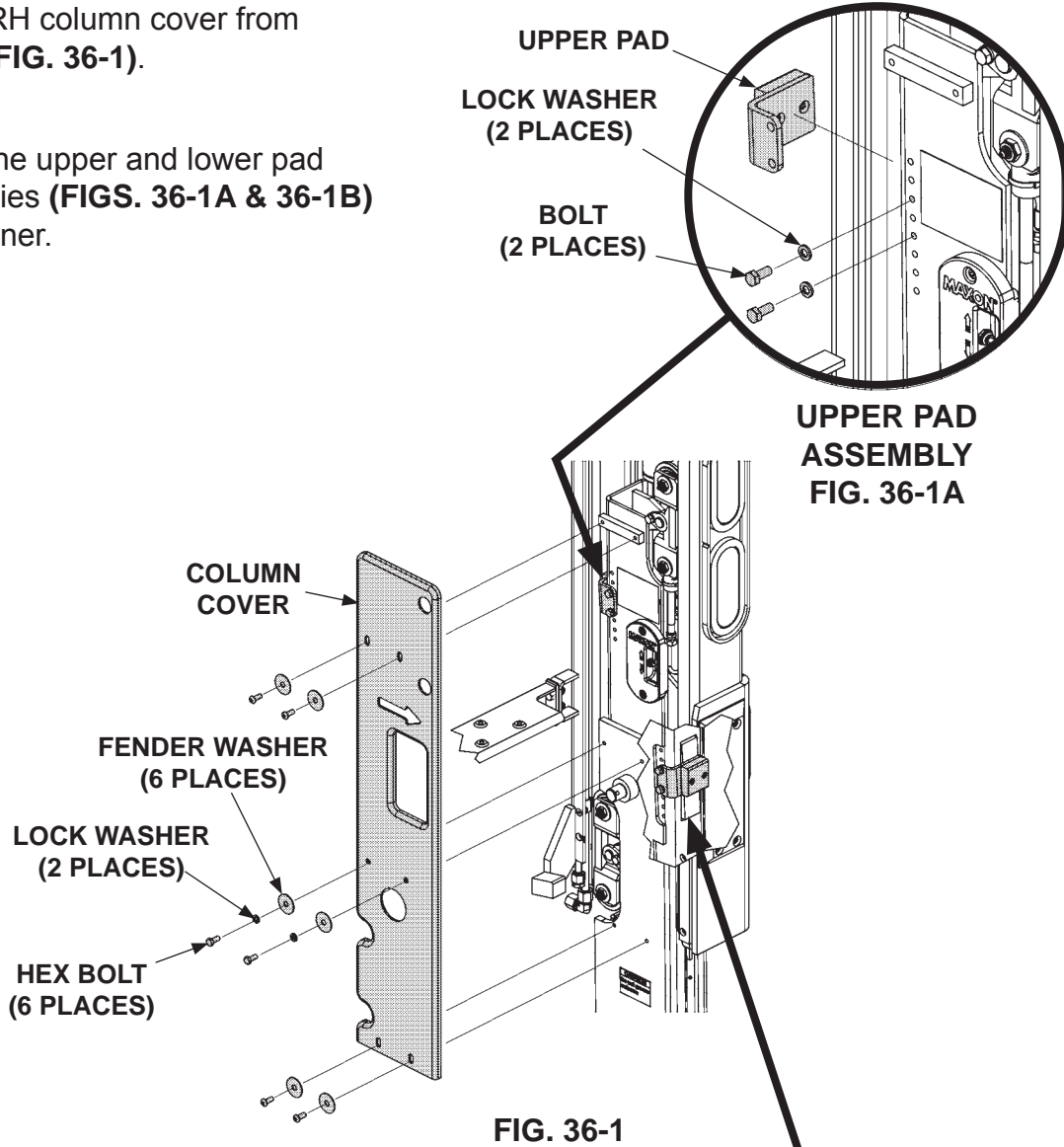
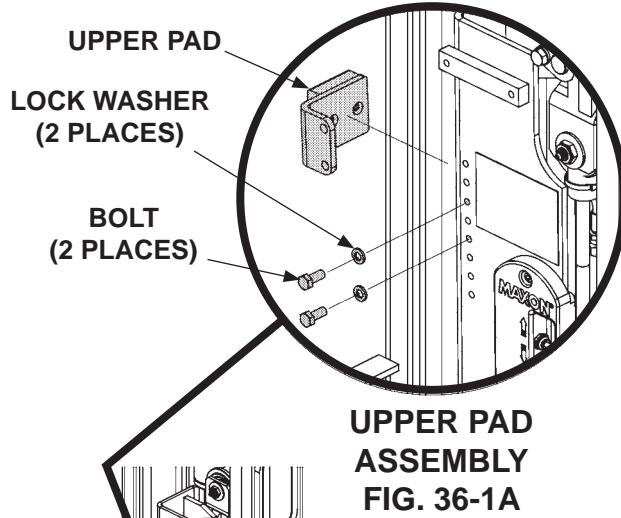
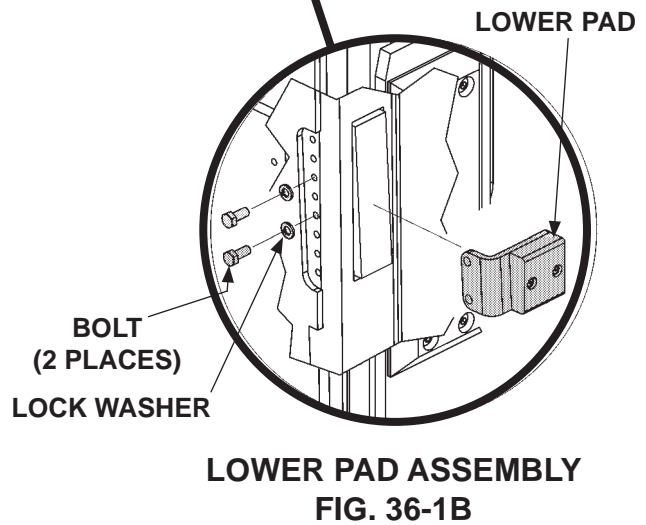

FIG. 36-1



UPPER PAD ASSEMBLY FIG. 36-1A



LOWER PAD ASSEMBLY FIG. 36-1B

REPLACING PARTS

RUNNER REPLACEMENT - Continued

12. If Liftgate is equipped with tandem rollers, unbolt the anchor pin from the tandem roller at the top of runner (**FIG. 37-1**). Next, move top of runner toward vehicle body for enough clearance to remove tandem rollers. Then, remove the tandem rollers (**FIG. 37-1**).

NOTE: If more clearance is necessary to remove the tandem rollers at the bottom of runner, unbolt roller bracket from the rollers.

13. For the tandem rollers at the bottom of runner, unbolt the anchor pin (**FIG. 37-1**). Next, move bottom of runner away from vehicle body for enough clearance to remove tandem rollers. Then, remove the tandem rollers (**FIG. 37-1**).

14. If Liftgate is equipped with tandem assembly with slide pads, unbolt the anchor pin from the slide pad assembly at the top of runner (**FIG. 37-2**). Next, move top of runner toward vehicle body for enough clearance to remove slide pad assembly. Remove the slide pad assembly (**FIG. 37-2**).

15. For the slide pad assembly at the bottom of runner, unbolt the anchor pin (**FIG. 37-2**). Next, move bottom of runner away from vehicle body for enough clearance to remove slide pad assembly. Remove the slide pad assembly (**FIG. 37-2**).

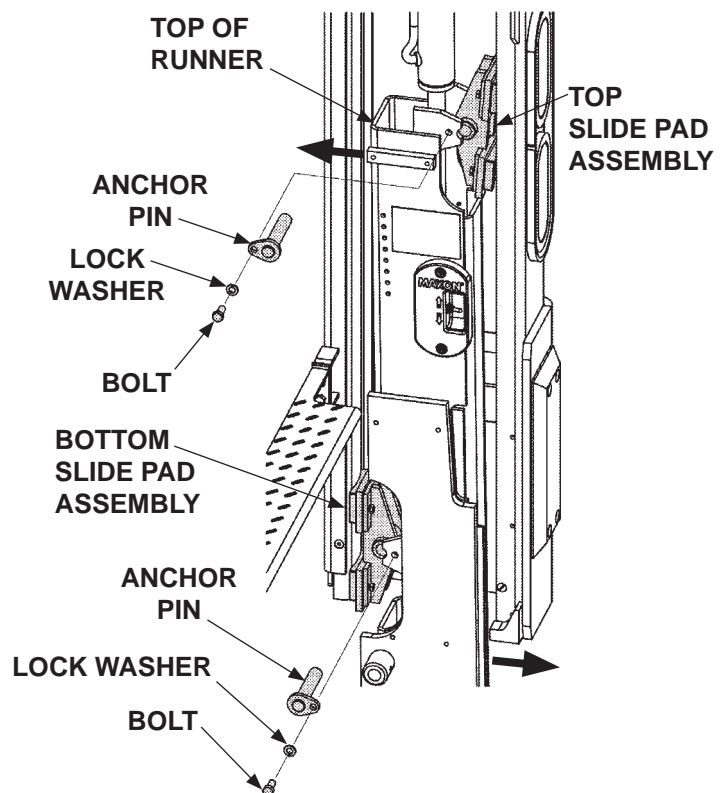
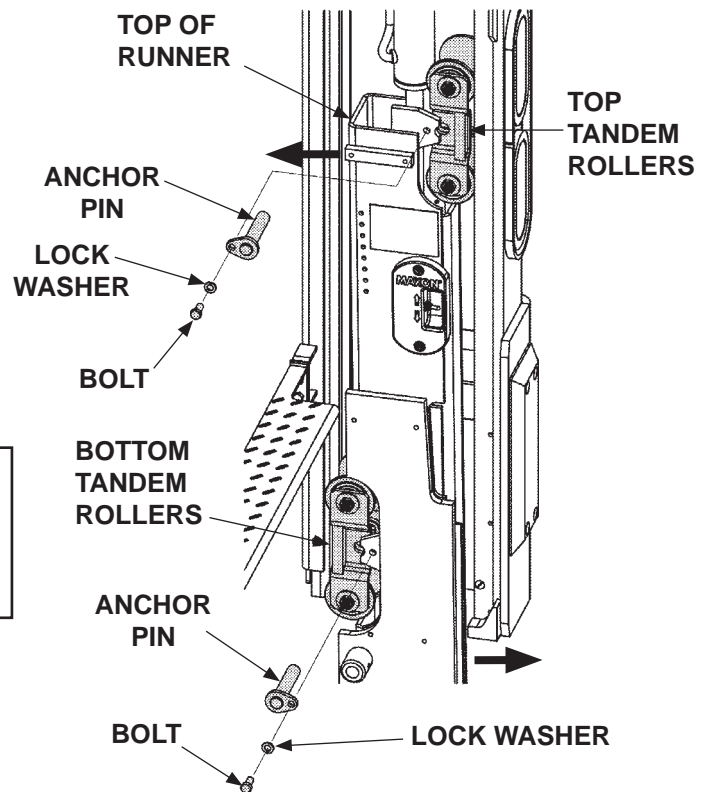

16. Disconnect lifting hydraulic line from fitting on flow control valve near top of lifting cylinder. Hold cylinder firmly and remove roll pin and upper pin (FIG. 38-1).

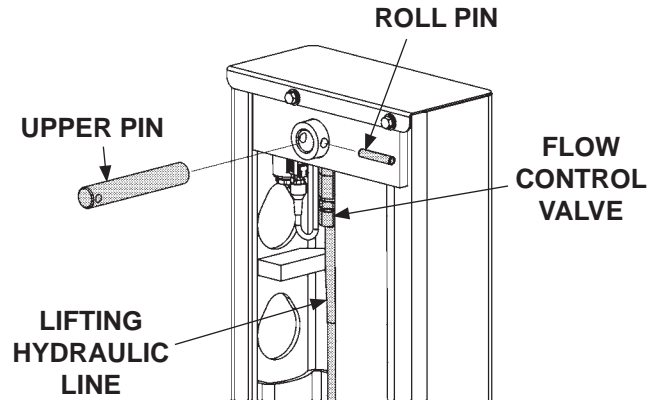
**FIG. 38-1**

17. Lower cylinder slowly a few inches to gain access to hydraulic line connector (FIG. 38-2). Plug the lifting line to prevent cylinder from compressing.

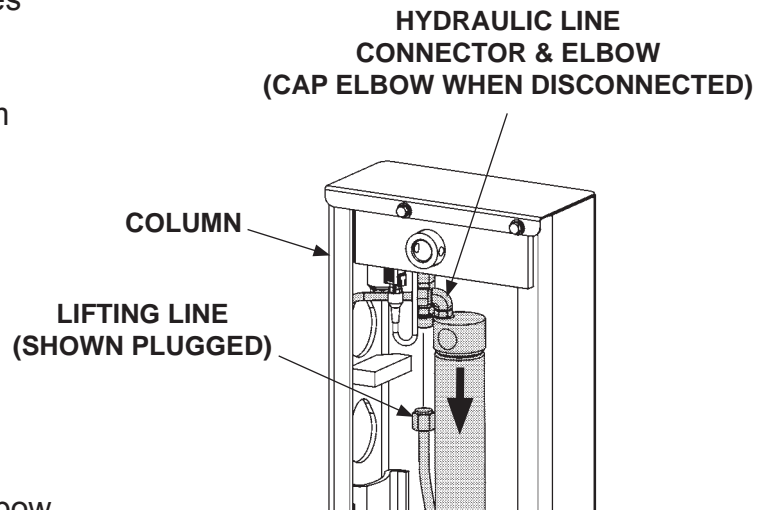
**FIG. 38-2**

18. Disconnect hydraulic line from elbow on top of cylinder (FIG. 38-2). Then cap the elbow.

REPLACING PARTS RUNNER REPLACEMENT - Continued

19. Twist and walk runner out of column (FIG. 39-1). Then lay runner and cylinder on the ground.

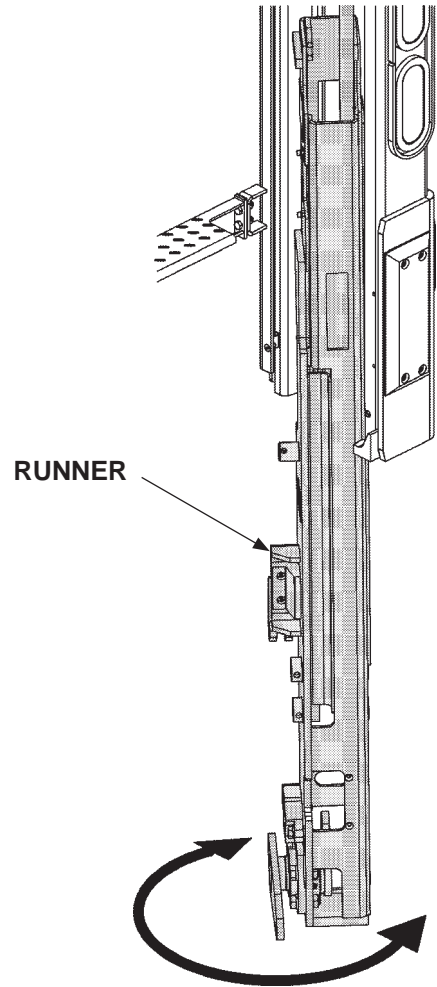

FIG. 39-1

CAUTION
Prevent damage to cylinder rod.
Be careful removing cylinder from runner.

20. Remove roll pin and lower pin from runner (FIG. 39-2). Pull cylinder from runner.

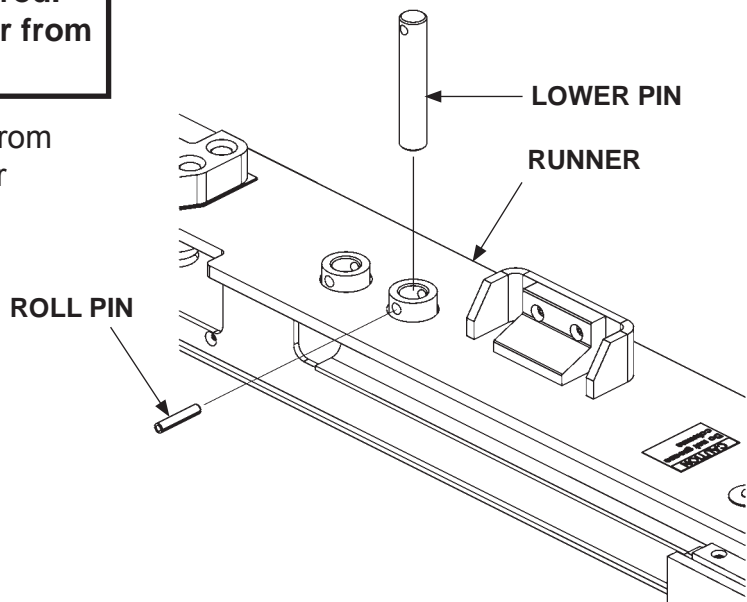
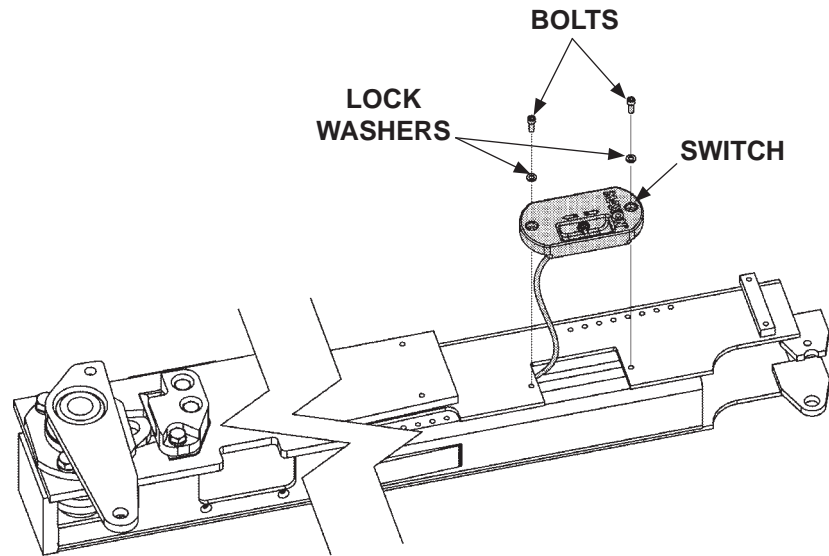

FIG. 39-2

21. If RH runner is being replaced, unbolt switch as shown in **FIG. 40-1**. Pull switch and cable from the runner.



REMOVING SWITCH FROM RH RUNNER
FIG. 40-1

CAUTION

Avoid making sharp bends in wiring.

22. If RH runner is being replaced, reinstall switch, bracket, and cable in runner as follows. Make a wire fish by feeding 8 feet of small gauge wire through switch opening in runner (**FIG. 40-1**). Pull wire through channel at lower end of runner. Leave enough wire at the switch opening to attach to switch cable, and enough wire to pull at the lower end of runner. Tie upper end of wire fish to switch cable connector. Pull connector and cable through runner until connector exits lower end of runner. Then, bolt switch mounting bracket to runner (**FIG. 40-1**).

REPLACING PARTS RUNNER REPLACEMENT - Continued

CAUTION

Prevent damage to cylinder rod.
Be careful inserting cylinder in
runner.

23. Slide rod end of lifting cylinder in
top of runner (**FIG. 41-1**). Then
reinstall lower pin and roll pin
(**FIG. 41-2**).

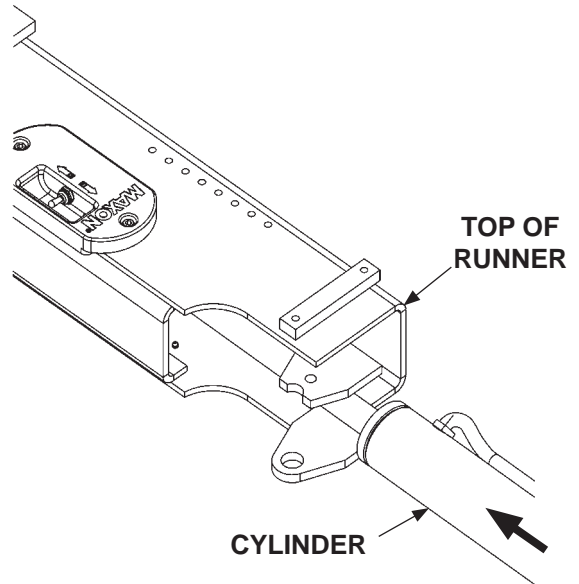

INSERTING CYLINDER IN RUNNER
FIG. 41-1

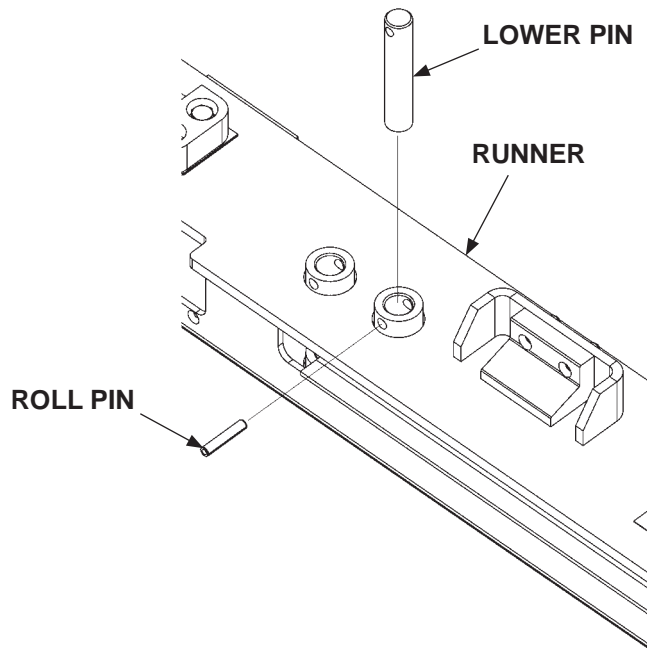

FIG. 41-2

24. Stand the runner and cylinder upright. Twist and walk runner into column (FIG. 42-1).

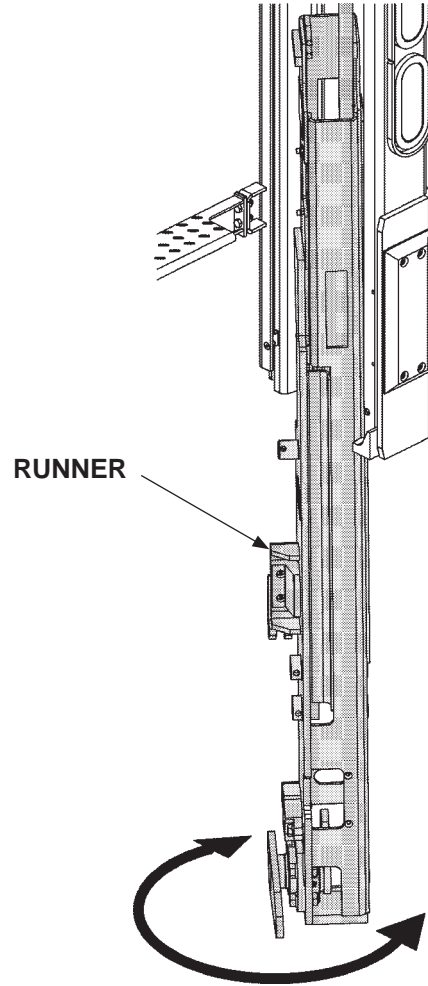

FIG. 42-1

25. Remove cap from elbow on top of cylinder (FIG. 42-2). Then re-connect power down line to elbow.

26. Remove plug from lifting line (FIG. 42-2). Then, raise the cylinder to line up the holes on cylinder and column.

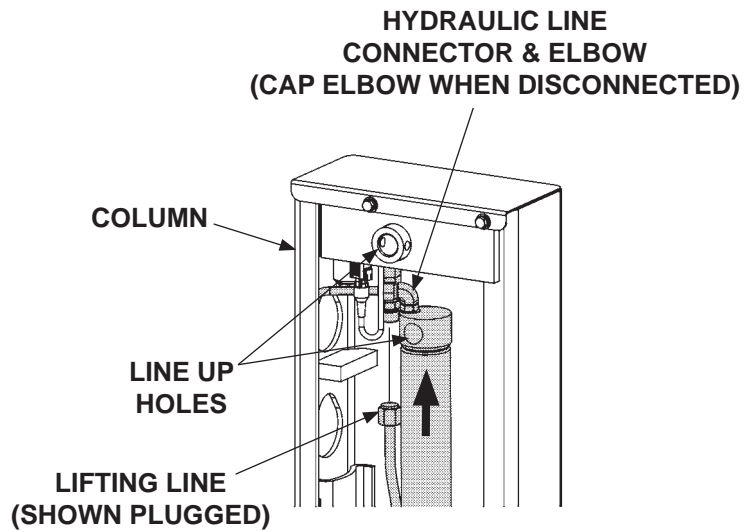

FIG. 42-2

REPLACING PARTS RUNNER REPLACEMENT - Continued

27. Holding the cylinder firmly, reinstall upper pin and roll pin (FIG. 43-1). Then, reconnect lifting line to flow control valve (FIG. 43-1).

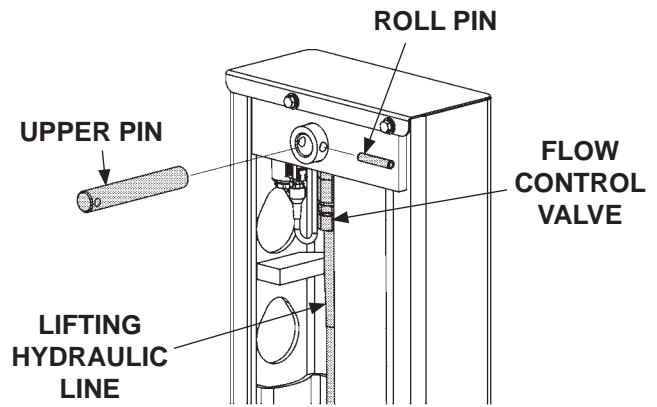

FIG. 43-1

NOTE: If roller bracket was unbolted from tandem rollers, reinstall bracket when tandem rollers are reinstalled at bottom of runner.

28. If Liftgate is equipped with tandem rollers, reinstall tandem rollers at the bottom of runner as follows. Move bottom of runner away from vehicle body for enough clearance to insert tandem rollers (FIG. 43-2). Insert tandem rollers in correct position. Then bolt anchor pin to runner (FIG. 43-2).

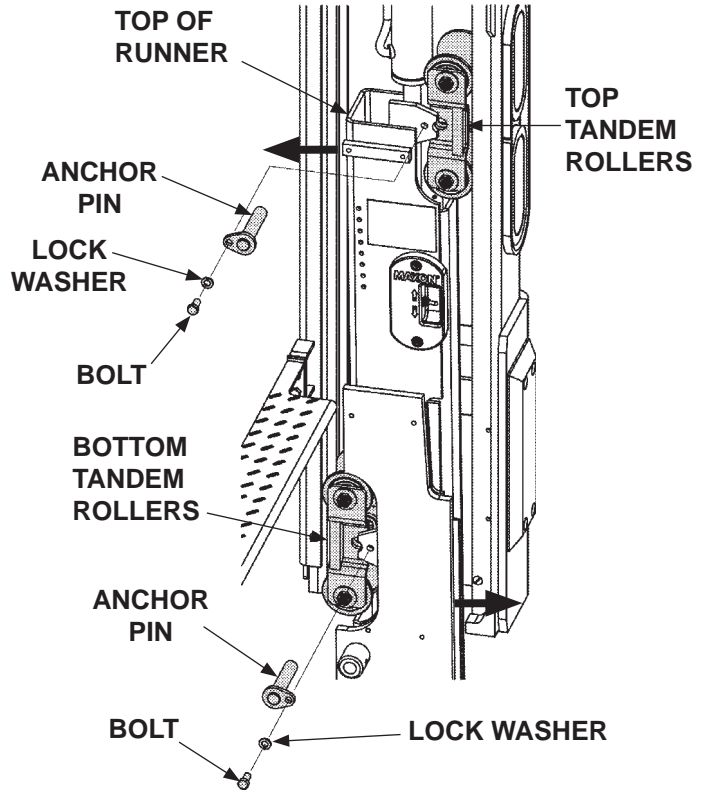
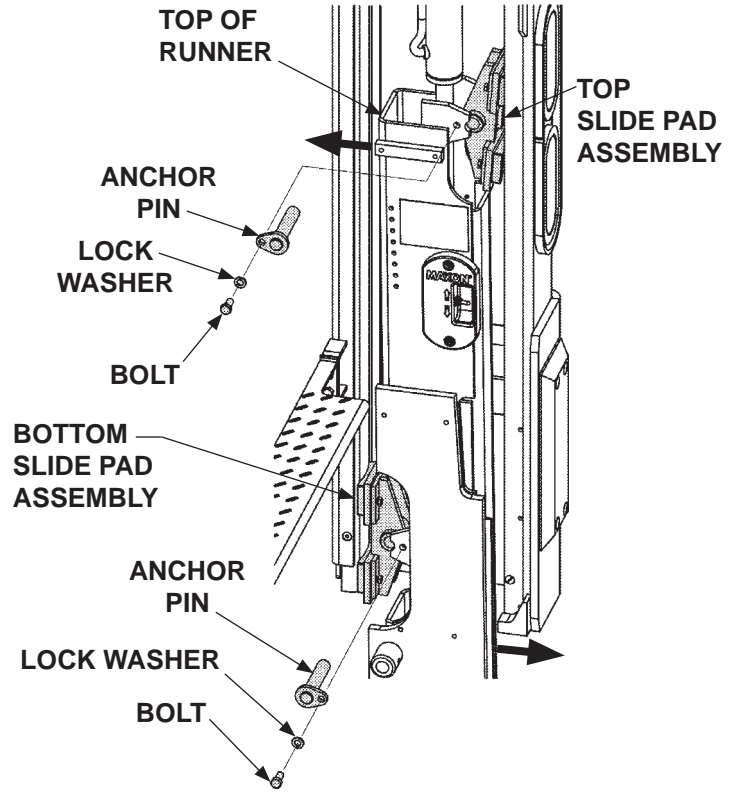

FIG. 43-2

29. To reinstall tandem rollers at top of runner, do the following. Move top of runner toward vehicle body for enough clearance to insert tandem rollers (FIG. 43-2). Insert the tandem rollers in correct position. Then bolt anchor pin to runner (FIG. 43-2).

30. If Liftgate is equipped with tandem slide pads, reinstall slide pad assembly at the bottom of runner as follows. Move bottom of runner away from vehicle body for enough clearance to insert slide pad assembly (FIG. 44-1). Insert slide pad assembly in correct position. Then bolt anchor pin to runner (FIG. 44-1).
31. To reinstall slide pad assembly at top of runner, do the following. Move top of runner toward vehicle body for enough clearance to insert slide pad assembly (FIG. 44-1). Insert slide pad assembly in correct position. Then bolt anchor pin to runner (FIG. 44-1).

**FIG. 44-1**

REPLACING PARTS RUNNER REPLACEMENT - Continued

NOTE: Clearance between runner pads and inner column guides should be as small as possible without interference. The Liftgate will not operate smoothly with zero (.00") clearance between pads and inner column.

32. Ensure the bottom tandem rollers are seated against inner column (FIG. 45-1). Next, slide the bottom pad down against wedge until there is no clearance between inner column and bottom pad (FIG. 45-1). Then, back off (slide up) bottom pad by 1 hole position to create clearance between pad and inner column.
33. Bolt bottom pad to runner with 2 bolts and 2 lock washers (FIG. 45-2). Torque the 2 bolts to 9-14 lb.-ft.

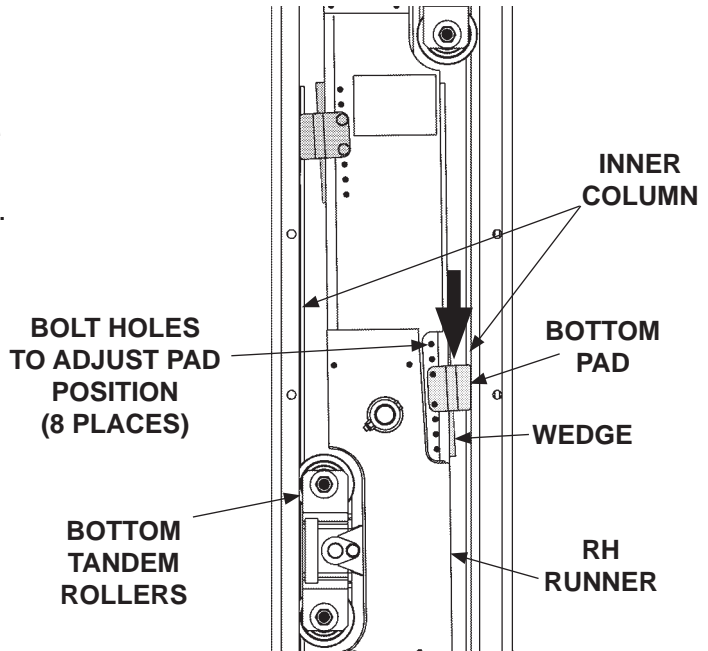

**ADJUSTING LOWER PAD
(RH RUNNER SHOWN)
FIG. 45-1**

NOTE: Keep spacer pad in place between inner column & runner after unbolting pad from runner.

34. Unbolt upper spacer pad from runner (FIG. 45-2). Keep bolts & lock washers to reinstall.
35. Ensure upper tandem rollers are seated against inner column (FIG. 45-2). Next, slide the upper pad up against wedge until there is no clearance between inner column and upper pad (FIG. 45-1). Then, back off (slide down) lower pad by 1 hole position to create clearance between upper pad and inner column.

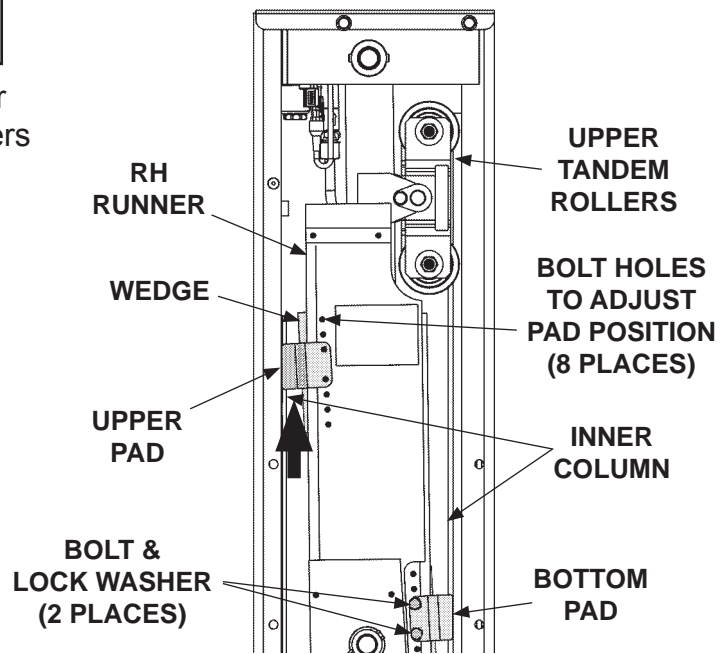

**BOLTING LOWER PAD & ADJUSTING
UPPER PAD (RH RUNNER SHOWN)
FIG. 45-2**

36. Bolt upper pad to RH runner with 2 bolts and 2 lock washers (**FIG. 46-1**). Torque the 2 bolts to **9-14 lb.-ft.**

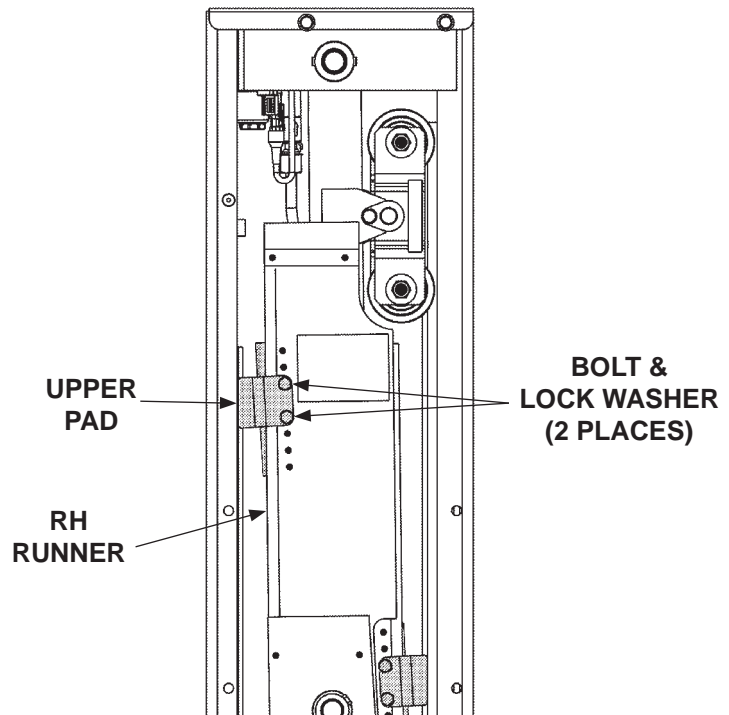

**BOLTING UPPER PAD
(RH RUNNER SHOWN)
FIG. 46-1**

NOTE: The serial plate must be transferred from old runner to new runner.

37. Bolt cover to runner (**FIG. 46-2**). Torque the 6 bolts to **9-14 lb.-ft.**

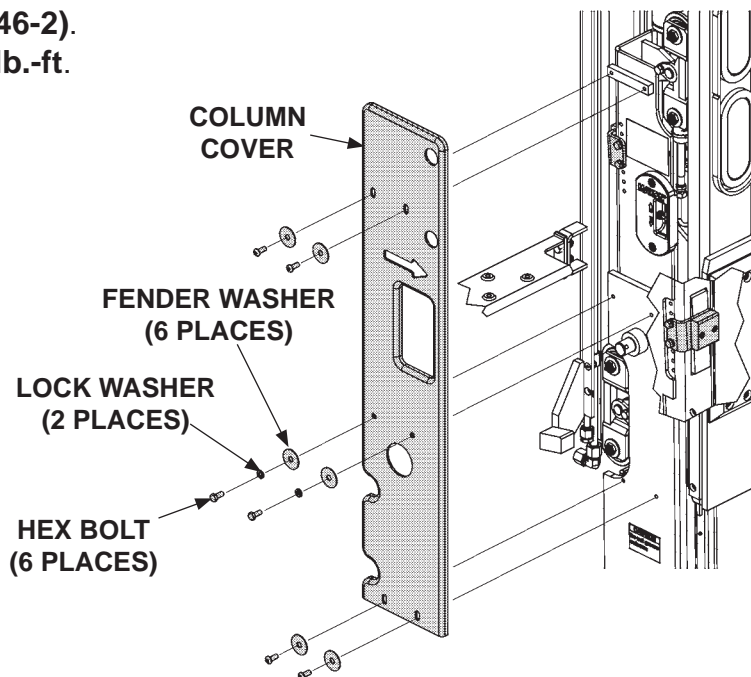

**BOLTING ON RUNNER COVER
FIG. 46-2**

REPLACING PARTS RUNNER REPLACEMENT - Continued

NOTE: If replacing LH runner, skip steps 38, 39 and 40.

38. Position flexible cable and twin hydraulic hoses in the channel at bottom of runner (**FIG. 47-1**).

CAUTION

Avoid making sharp bends in wiring.

NOTE: MAXON recommends using dielectric grease on all electrical connections.

39. Connect runner switch cable to flexible cable near bottom of runner as shown in **FIG. 47-1**. Then, use clamps and lock nuts to fasten molded portion of connectors to runner (**FIG. 47-1**).
40. To reinstall opening/closing cylinder, do the opening/closing cylinder replacement steps in the **OPENING/CLOSING CYLINDER REPLACEMENT** procedure in this manual.
41. Use a forklift or equivalent lifting device to lift platform and line it up with attaching points on the LH runner (**FIG. 47-2**) and RH runner.

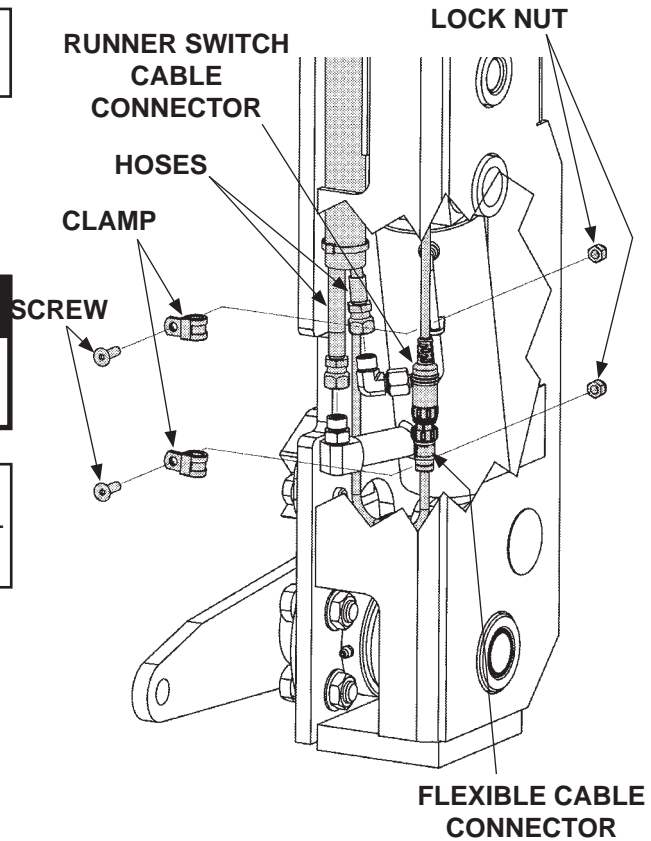

FIG. 47-1

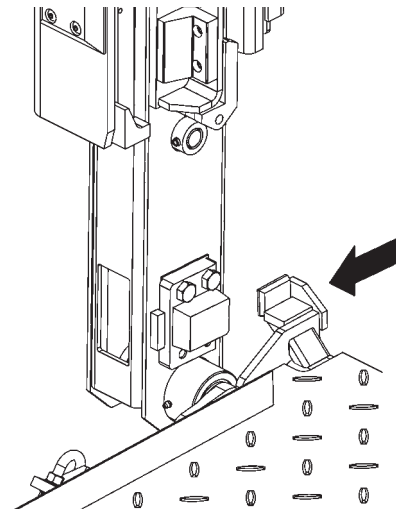
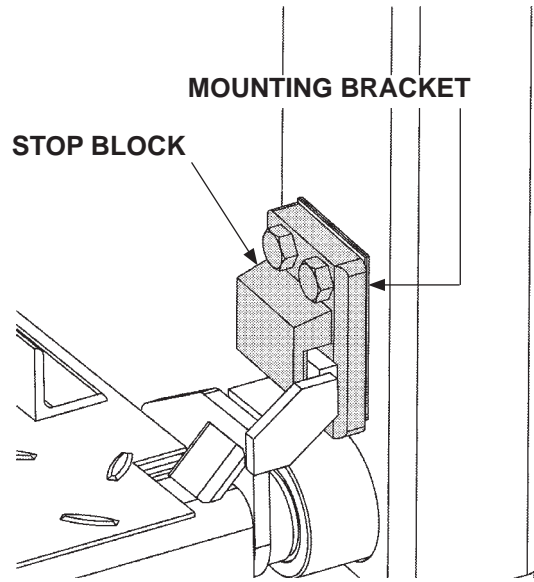

FIG. 47-2

NOTE: Perform this step only if the mounting bracket fits too tightly in the stop block (**FIG. 48-1**).

- 42. If LH mounting bracket fits too tight against either side of stop block **FIG. 48-1**, adjust with spacers as shown in **FIG. 48-2**.



**REAR VIEW OF LH RUNNER
FIG. 48-1**

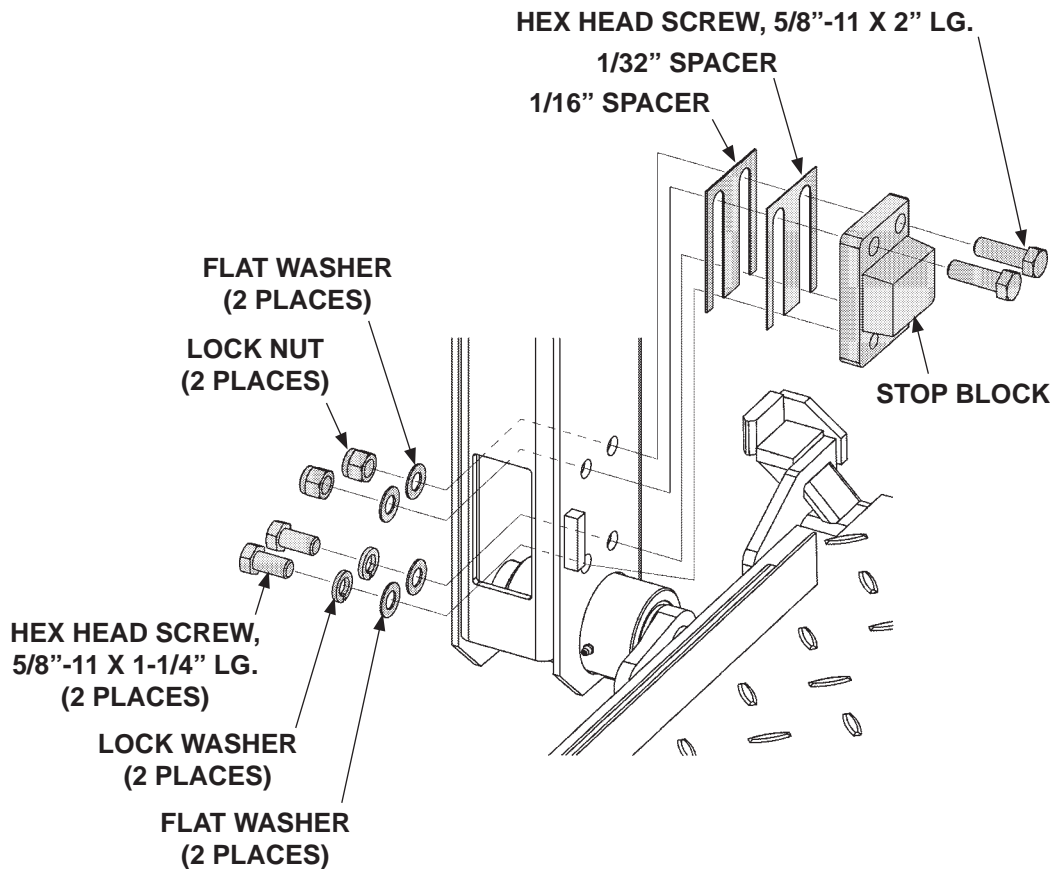

**FRONT VIEW OF LH RUNNER
FIG. 48-2**

REPLACING PARTS

RUNNER REPLACEMENT - Continued

NOTE: Perform this step only if the mounting bracket fits too tightly in the stop block (**FIG. 49-1**).

43. If RH mounting bracket fits too tight against either side of stop block **FIG. 49-1**, adjust with spacers as shown in **FIG. 49-2**.

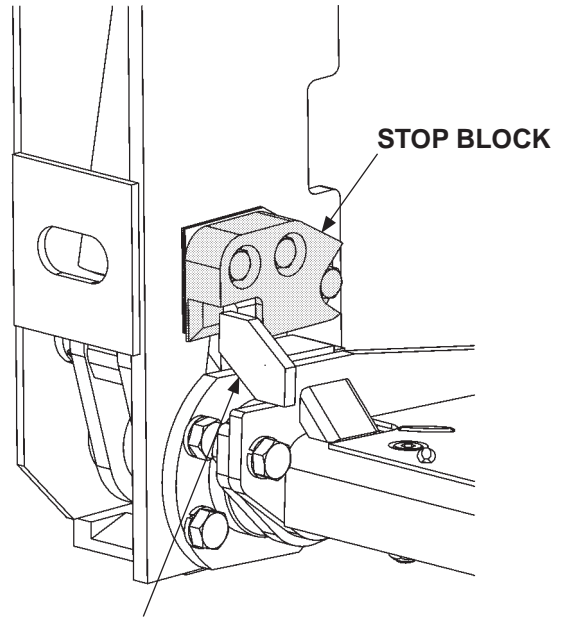

MOUNTING BRACKET

REAR VIEW OF RH RUNNER
FIG. 49-1

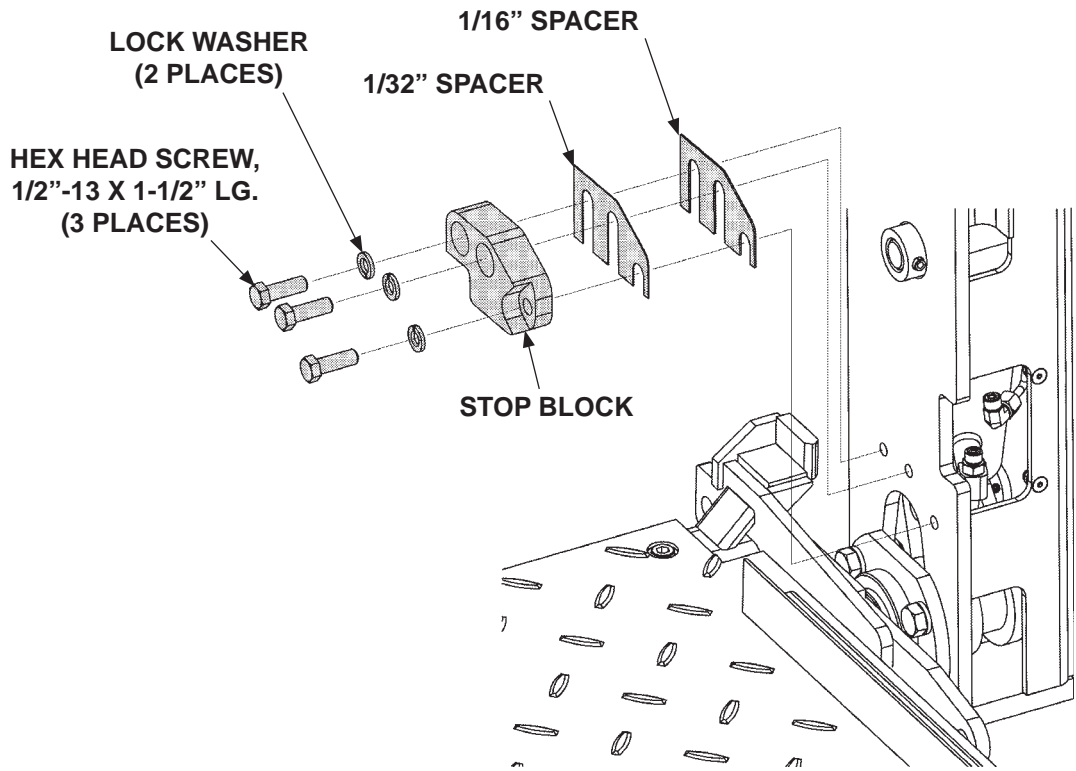

FRONT VIEW OF RH RUNNER
FIG. 49-2

44. Insert pin through runner, couplings and connector bar at the RH runner. Then, bolt platform and connector bar to pin (**FIG. 50-1**). Repeat for LH runner.

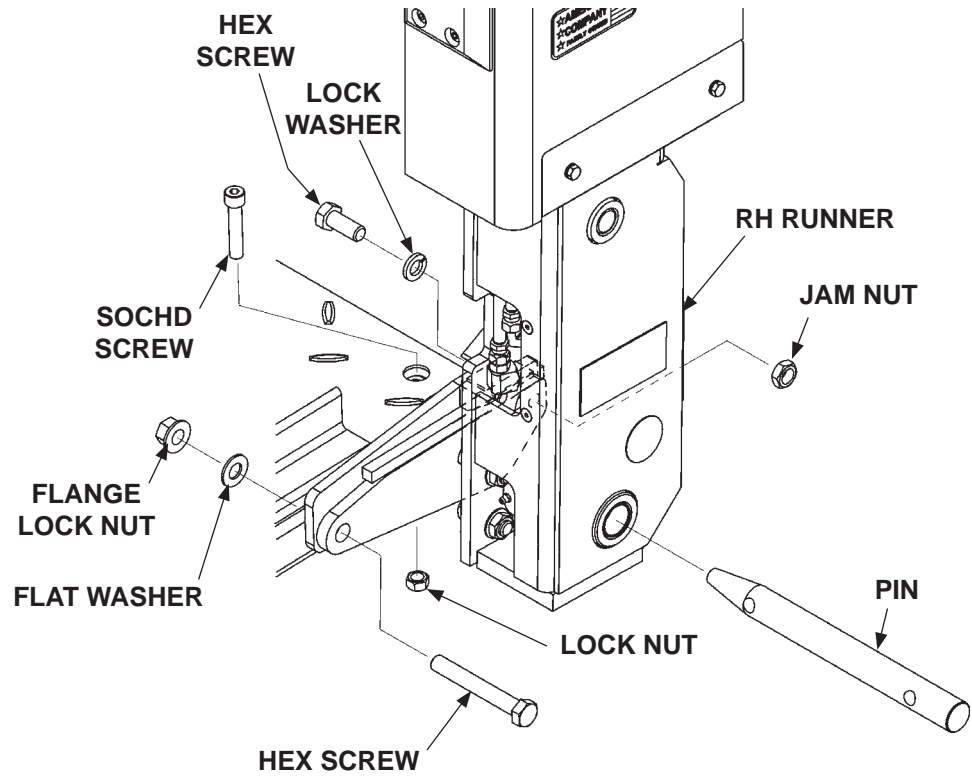
**FIG. 50-1**

REPLACING PARTS RUNNER REPLACEMENT - Continued

45. Raise the platform (**UP**) slightly and remove 2 jack stands near the inboard edge (**FIG. 51-1**).

46. Lower (**DOWN**) platform on jack stands (**FIG. 51-1**) so inboard edge is 4" below ramp edge.

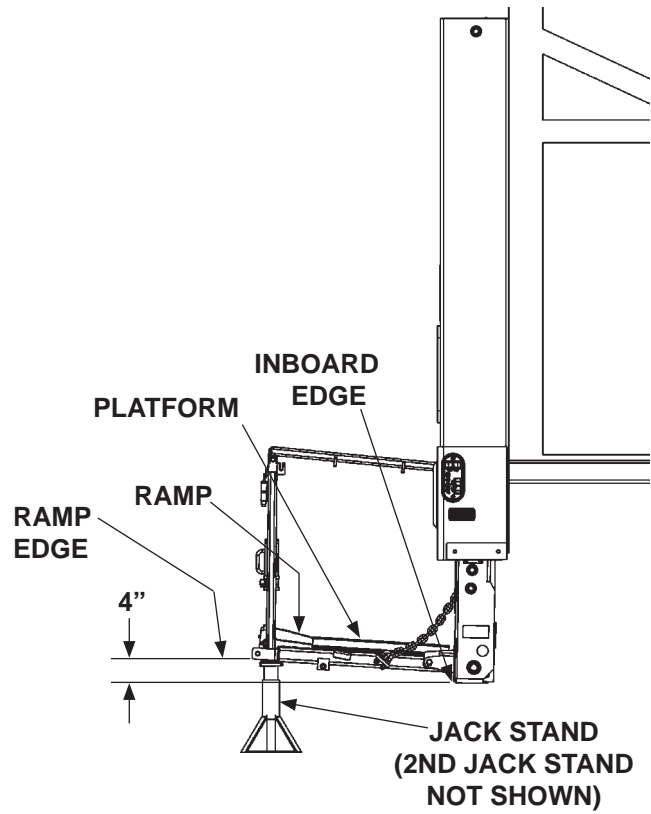

FIG. 51-1

47. Reattach cover to LH runner. Reinsert roll pin and opener pin into platform railing and attach to LH runner (**FIG 51-2**). Reinsert cotter pin and pin into chain bracket on LH runner (**FIG 51-2**). Repeat for RH chain bracket, platform railing and RH runner.

48. If necessary, do the **BLEEDING HYDRAULIC FLUID** procedure in this manual.

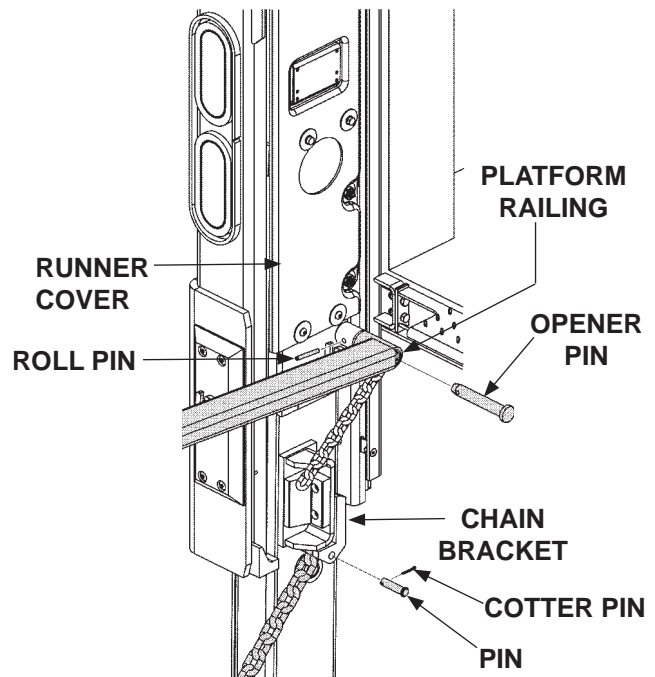
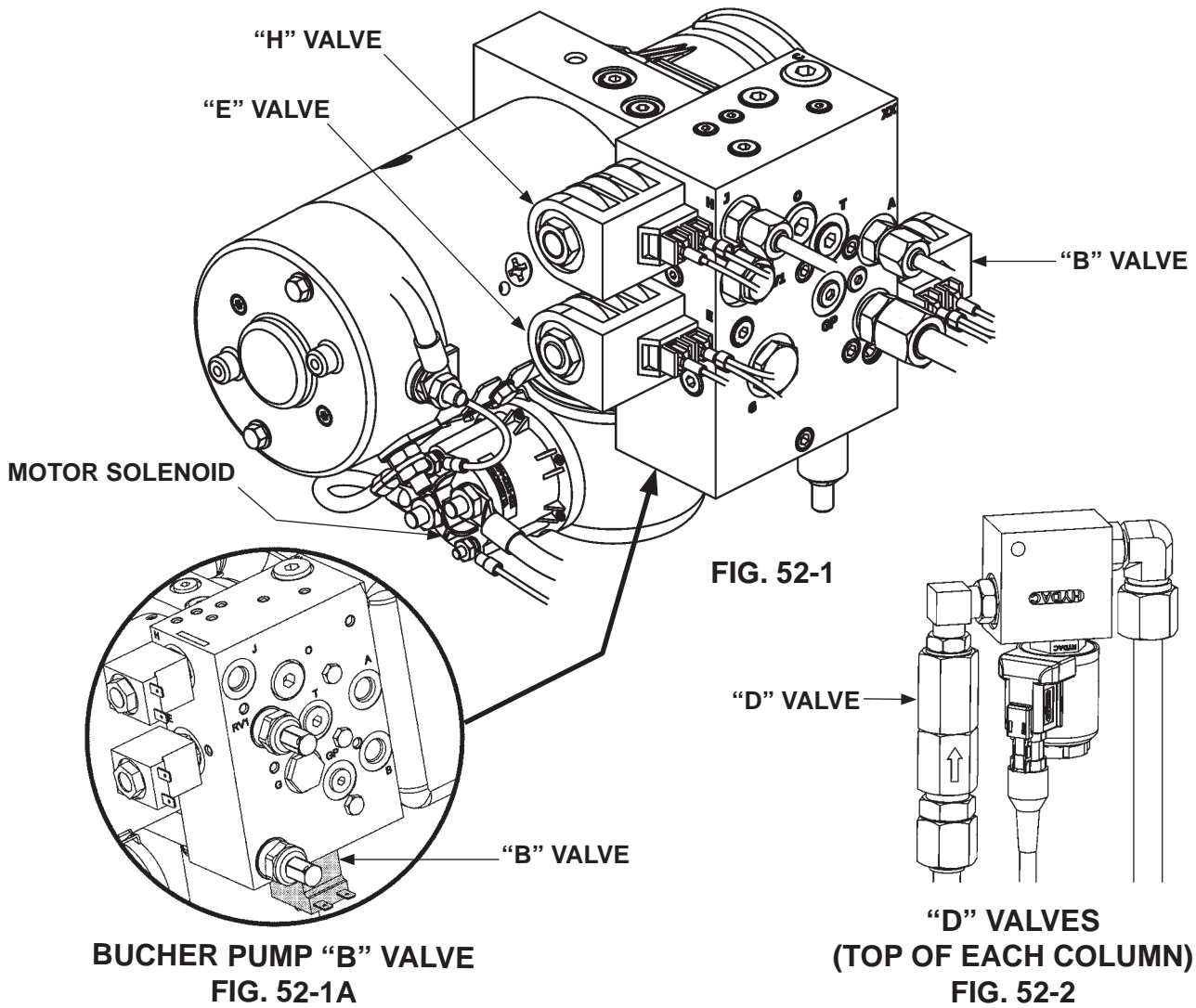

FIG. 51-2

HYDRAULIC SYSTEM DIAGRAMS

PUMP & MOTOR SOLENOID OPERATION - GRAVITY DOWN



POWER UNIT MOTOR & SOLENOID OPERATION - GRAVITY DOWN								
LIFTGATE FUNCTION	PORT	SOLENOID OPERATION (✓ MEANS ENERGIZED)						
		SWITCH	RELAY	MOTOR	VALVE “B”	VALVE “D”	VALVE “E”	VALVE “H”
LIFT	B	“GD”	-	✓	-	-	-	-
LOWER	C		✓	-	✓	✓	-	-
OPEN	J		-	✓	-	-	✓	✓
CLOSE	A		-	✓	-	-	✓	-
REFER TO VALVES SHOWN ON HYDRAULIC SCHEMATIC								

TABLE 52-1

HYDRAULIC SYSTEM DIAGRAMS - Continued

PUMP & MOTOR SOLENOID OPERATION - POWER DOWN

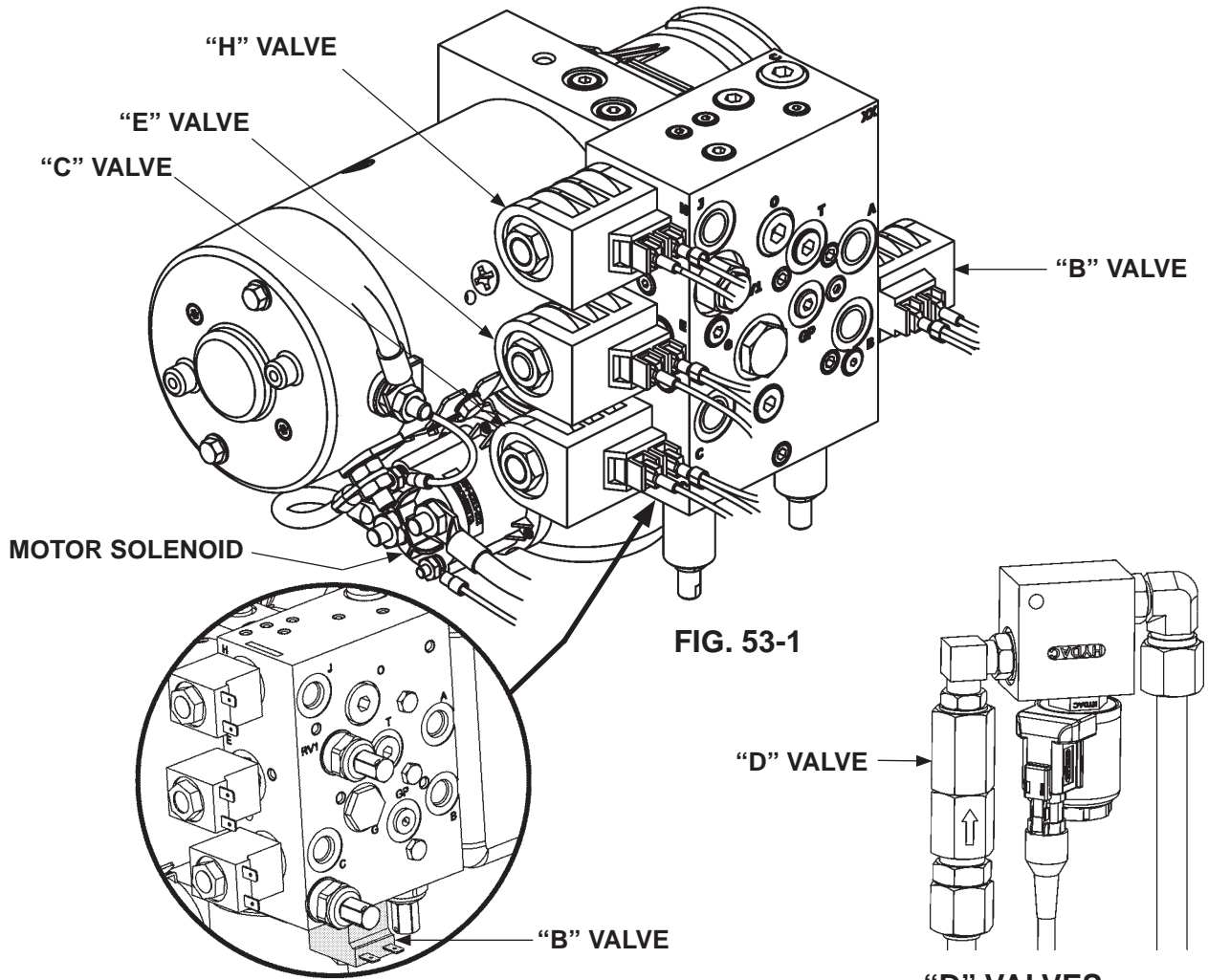

BUCHER PUMP "B" VALVE
FIG. 53-1A

"D" VALVES
(TOP OF EACH COLUMN)
FIG. 53-2

POWER UNIT MOTOR & SOLENOID OPERATION - POWER DOWN									
LIFTGATE FUNCTION	PORT	SOLENOID OPERATION (✓ MEANS ENERGIZED)							
		SWITCH	RELAY	MOTOR	VALVE "B"	VALVE "C"	VALVE "D"	VALVE "E"	VALVE "H"
LIFT	B	"PD"	-	✓	-	-	-	-	-
LOWER	C		-	✓	✓	✓	✓	-	-
OPEN	J		-	✓	-	-	-	✓	✓
CLOSE	A		-	-	-	-	-	-	-

REFER TO VALVES SHOWN ON HYDRAULIC SCHEMATIC

TABLE 53-1

ELECTRICAL CONTROLLER DIAGRAMS

CONTROLLER INDICATIONS

NOTE: For interpreting the controller indications and functions, the “i” over bar means the indication pertains to a switch input shown on the face of the controller. The “o” over bar means the indication pertains to a controller output shown on the face of the controller.

NOTE: The correct input LED and output LED must be illuminated to be a complete indication for each operating function.

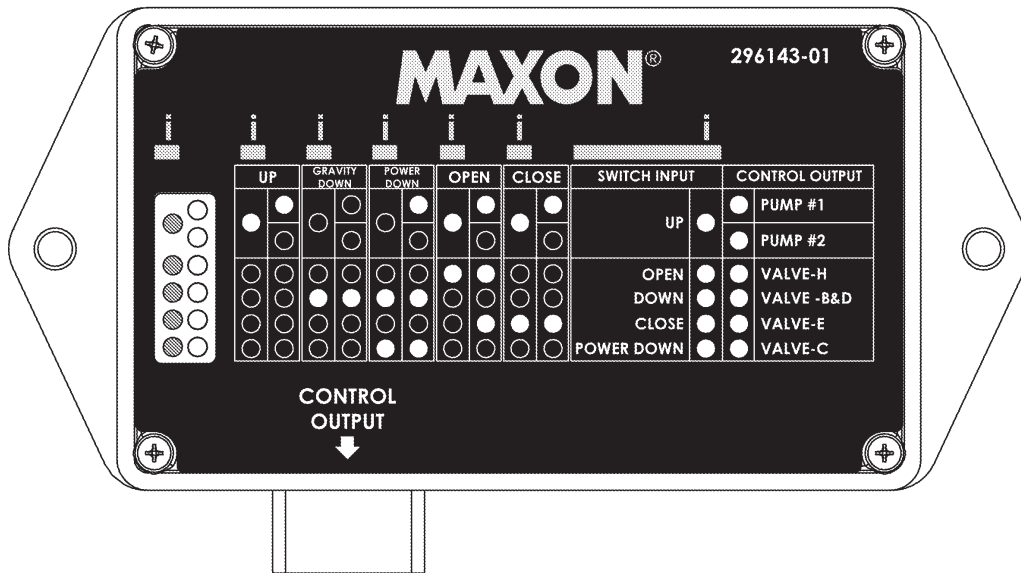

INDICATORS FOR SWITCH INPUTS
FIG. 54-1

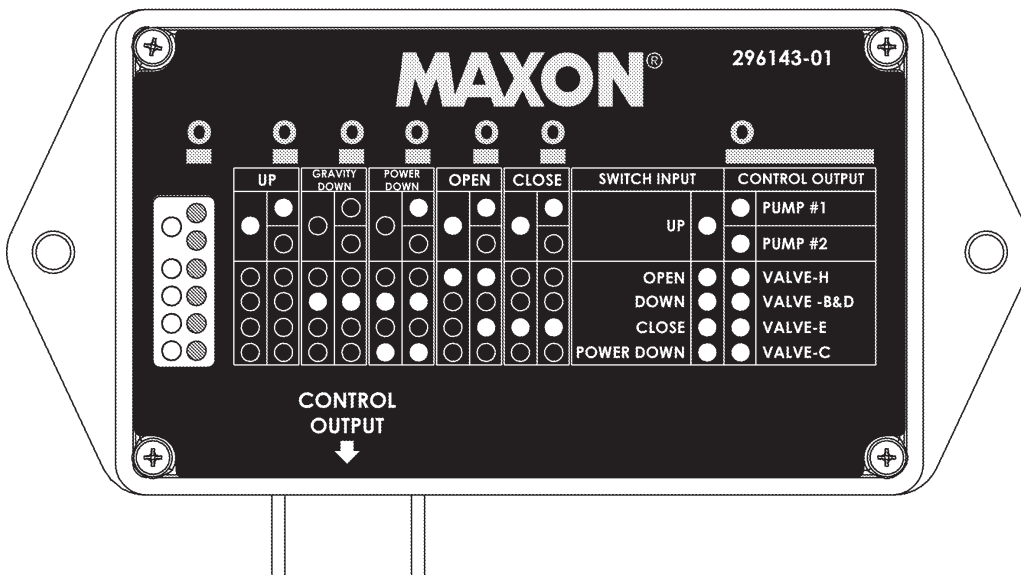

INDICATORS FOR CONTROLLER OUTPUTS
FIG. 54-2

ELECTRICAL CONTROLLER DIAGRAMS - Continued

CONTROLLER INDICATIONS - CONTINUED

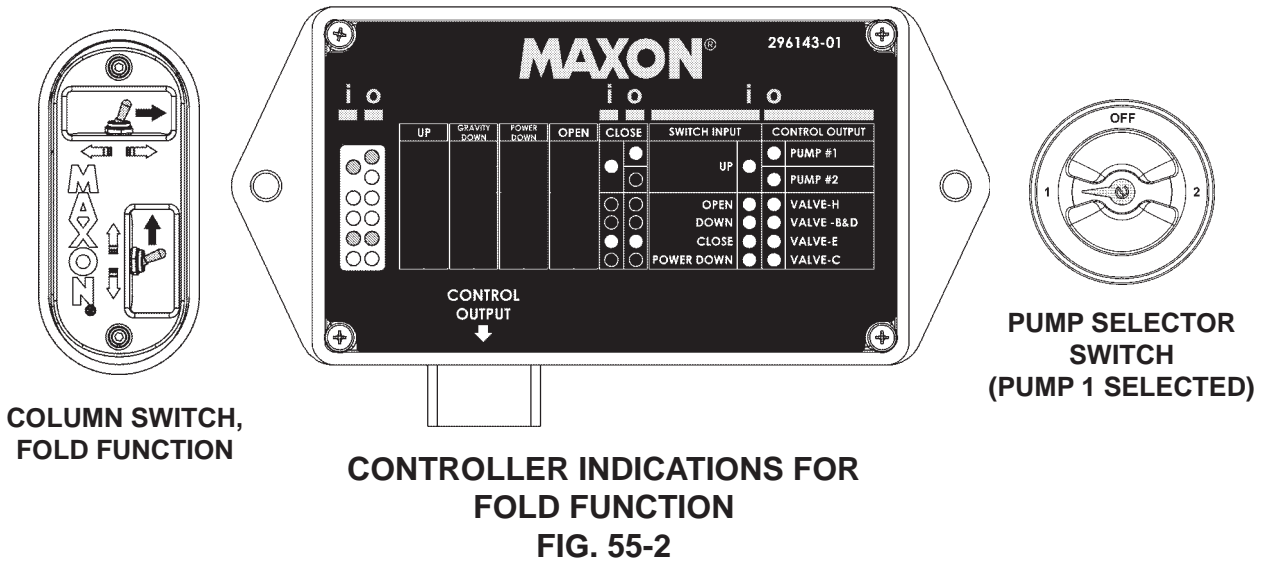
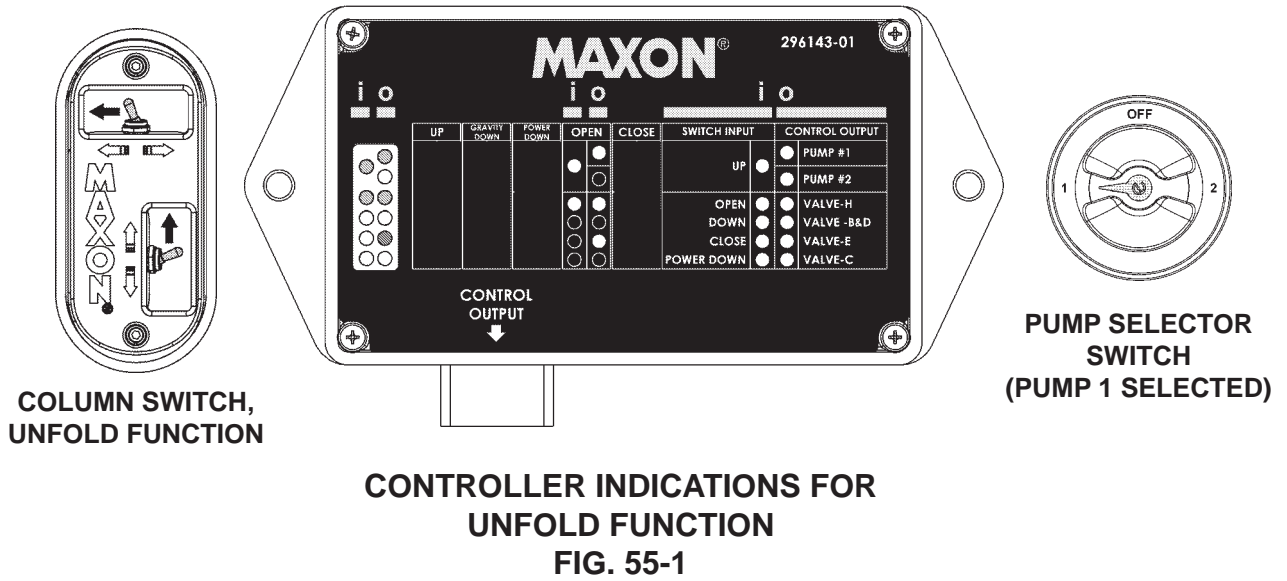

MAXON® 11921 Slauson Ave. Santa Fe Springs, CA. 90670 (800) 227-4116 FAX (888) 771-7713

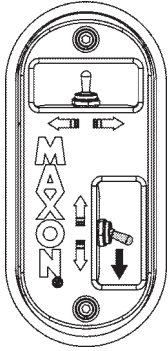

**COLUMN SWITCH,
GRAVITY DOWN FUNCTION**

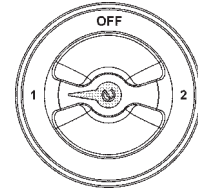
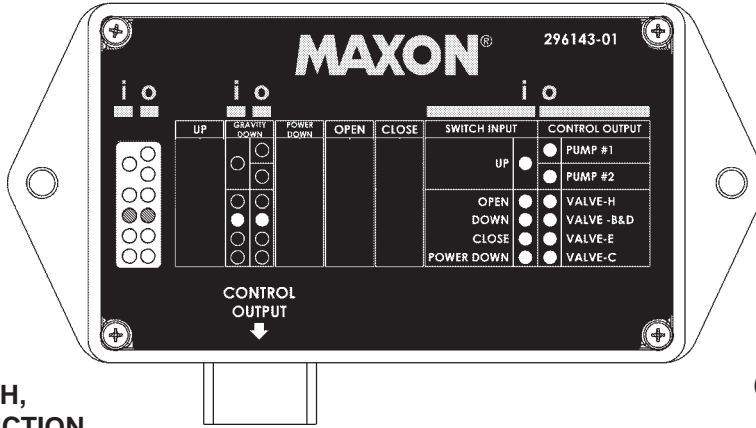

**PUMP SELECTOR
SWITCH
(PUMP 1 SELECTED)**

**CONTROLLER INDICATIONS FOR
GRAVITY DOWN FUNCTION
FIG. 56-1**

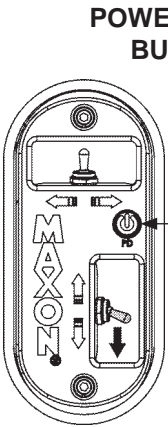

**COLUMN SWITCH,
POWER DOWN FUNCTION**

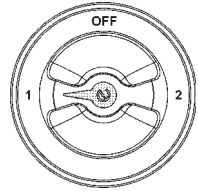
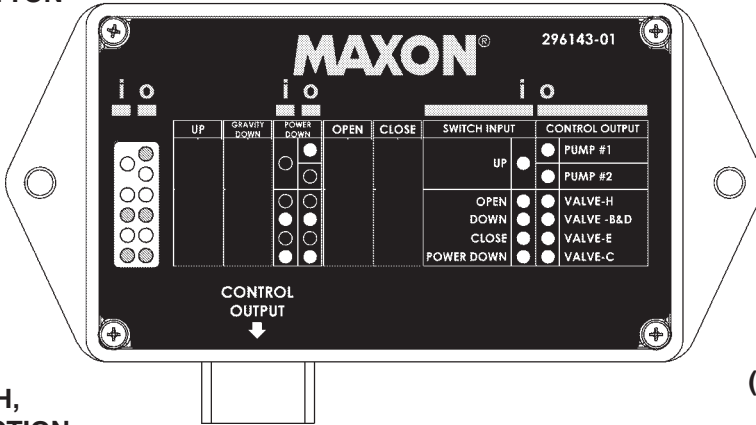

**PUMP SELECTOR
SWITCH
(PUMP 1 SELECTED)**

**CONTROLLER INDICATIONS FOR
POWER DOWN FUNCTION
FIG. 56-2**

ELECTRICAL CONTROLLER DIAGRAMS - Continued

CONTROLLER INDICATIONS - CONTINUED

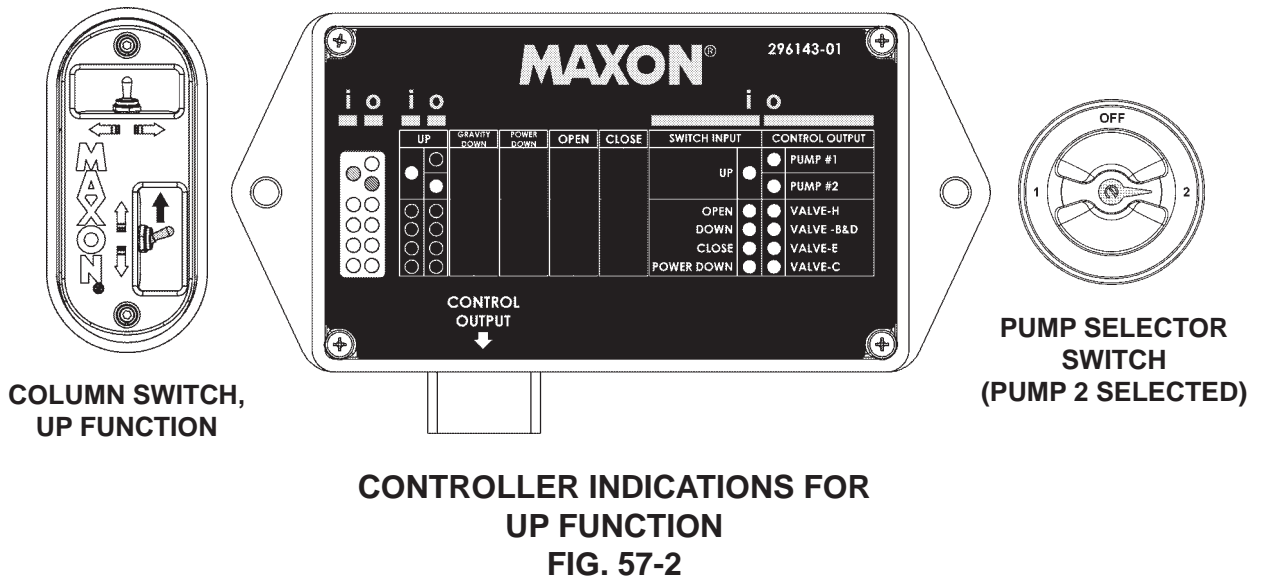
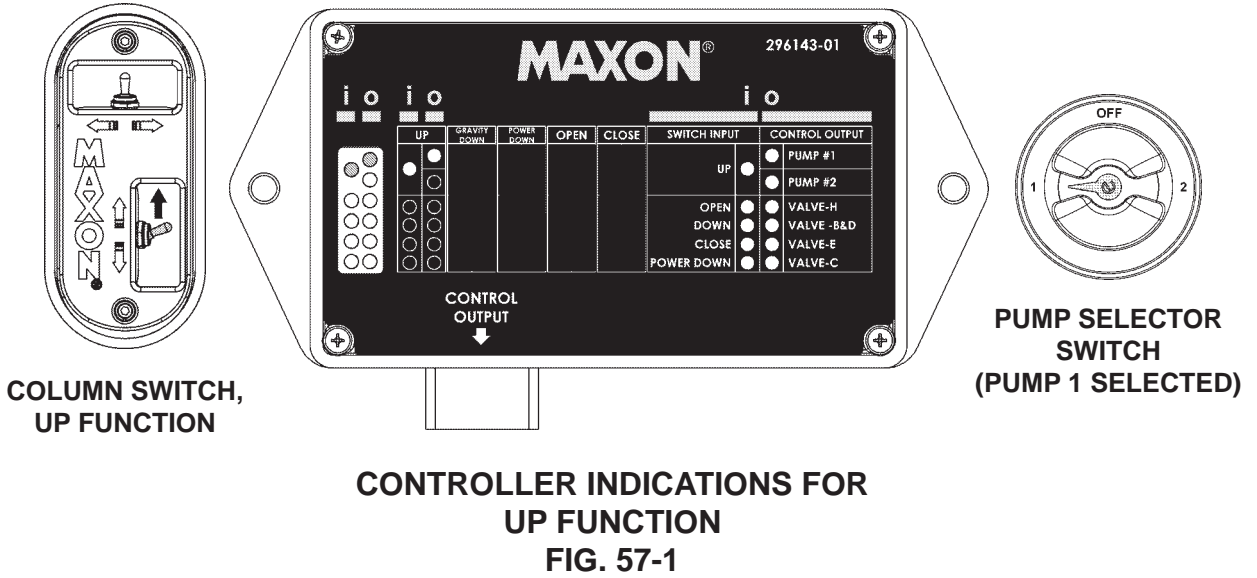

MAXON 11921 Slauson Ave. Santa Fe Springs, CA. 90670 (800) 227-4116 FAX (888) 771-7713

ELECTRICAL CONTROLLER DIAGRAMS - Continued

CONTROLLER INPUT LED(S) ILLUMINATED, BUT OUTPUT LED(S) NOT ILLUMINATED

If controller input LED's are illuminated, but output LED's are not illuminated (**FIG. 59-1**), check for 12.4VDC minimum at motor solenoid battery power terminal (green wire for pump #1 or yellow wire for pump # 2). If this check is correct, ensure the 12-pin valve wiring harness, connected to the Control Output, is securely connected. Refer to **GRAVITY DOWN OR POWER DOWN SINGLE & DUAL PUMP ELECTRICAL SCHEMATIC**. If problem still exists, replace the controller.

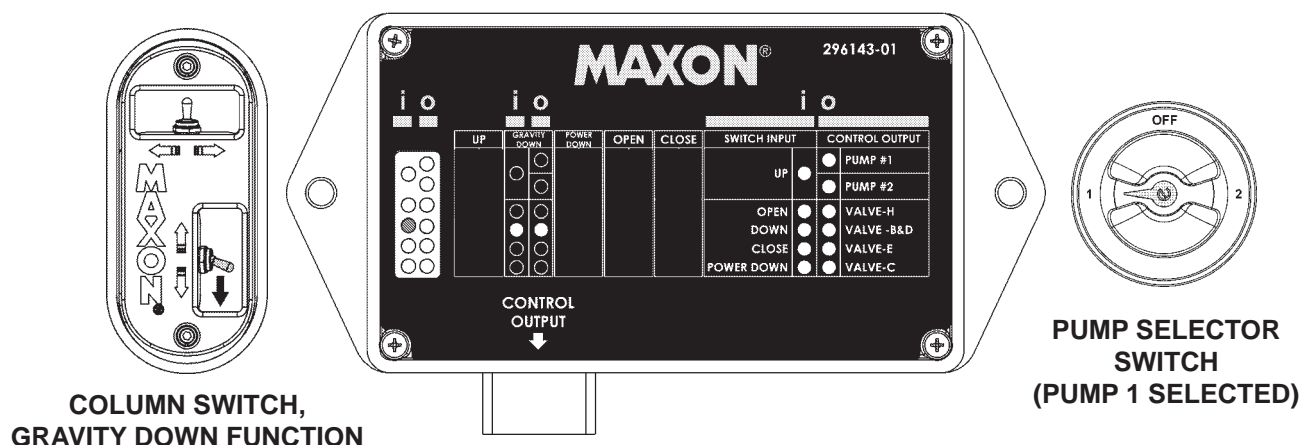

NO INDICATORS FOR CONTROLLER OUTPUT
FIG. 59-1

MAXON 11921 Slauson Ave. Santa Fe Springs, CA. 90670 (800) 227-4116 FAX (888) 771-7713

CONTROLLER INPUT LED(S) & OUTPUT LED(S) ILLUMINATED, BUT LOSS OF LIFTGATE FUNCTION

If controller input and output LED's are illuminated (**FIG. 60-1**), but the **UP**, **DOWN**, **FOLD** or **UNFOLD** function does not work, check for 10VDC minimum at the applicable valve coils. Next, check the ground circuit for the selected function. Ground wire should show 0VDC. If these checks are correct, ensure the 12-pin valve wiring harness, connected to the Control Output, is securely connected. Refer to **GRAVITY DOWN OR POWER DOWN SINGLE & DUAL PUMP ELECTRICAL SCHEMATIC**.

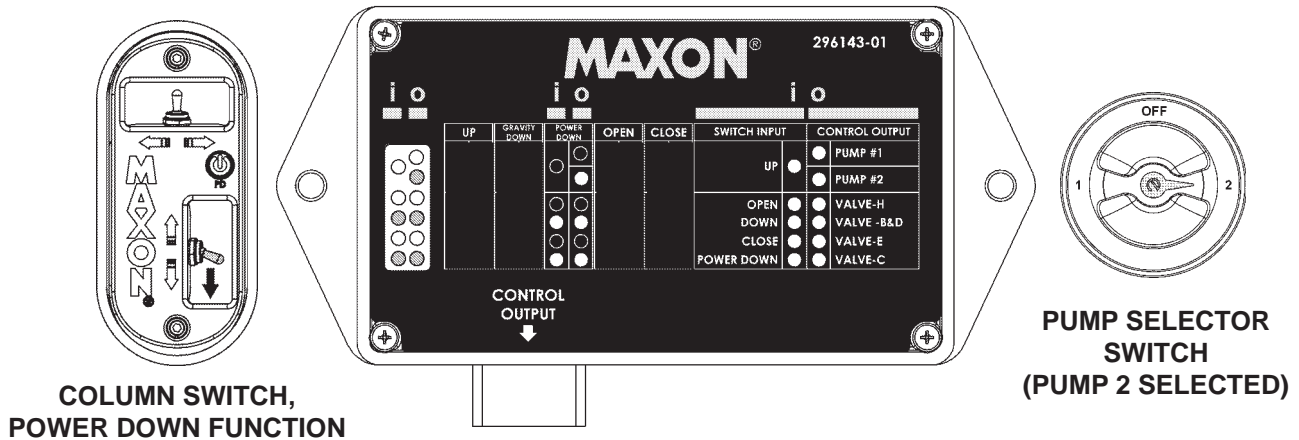

**INPUT & OUTPUT INDICATORS ILLUMINATED, BUT LOSS OF LIFTGATE FUNCTION
FIG. 60-1**

HYDRAULIC SYSTEM DIAGRAMS

GRAVITY DOWN HYDRAULIC SCHEMATIC

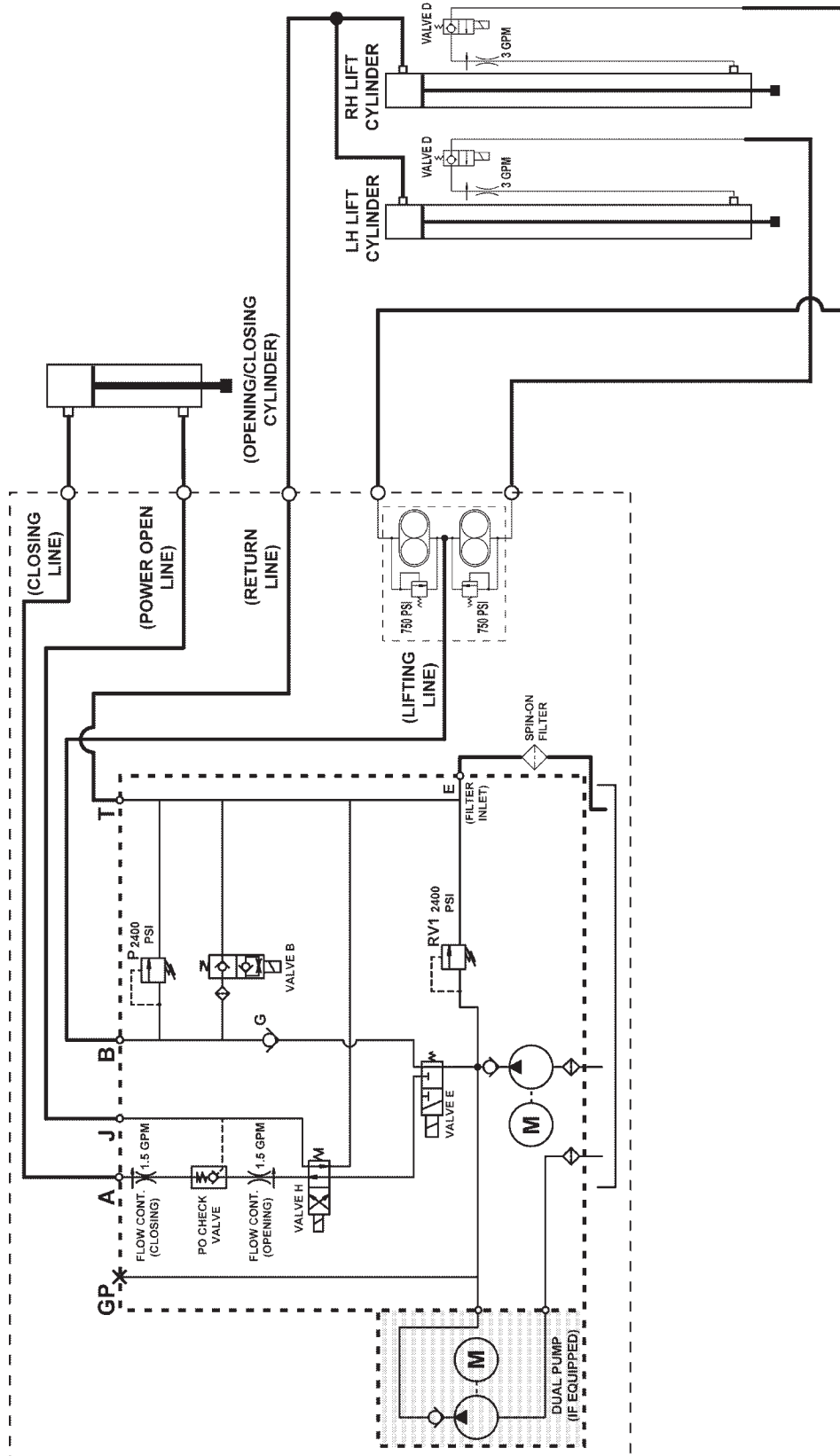

FIG. 61-1

MAXON[®]

11921 Slauson Ave. Santa Fe Springs, CA. 90670 (800) 227-4116 FAX (888) 771-7713

THIS PAGE INTENTIONALLY LEFT BLANK.

HYDRAULIC SYSTEM DIAGRAMS

GRAVITY DOWN HYDRAULIC LINES IDENTIFICATION

NOTE: See TABLES 65-1 & 65-2 for information on the numbered hoses in this illustration.

CAUTION
Before connecting hoses, ensure face seal o-rings are in place.

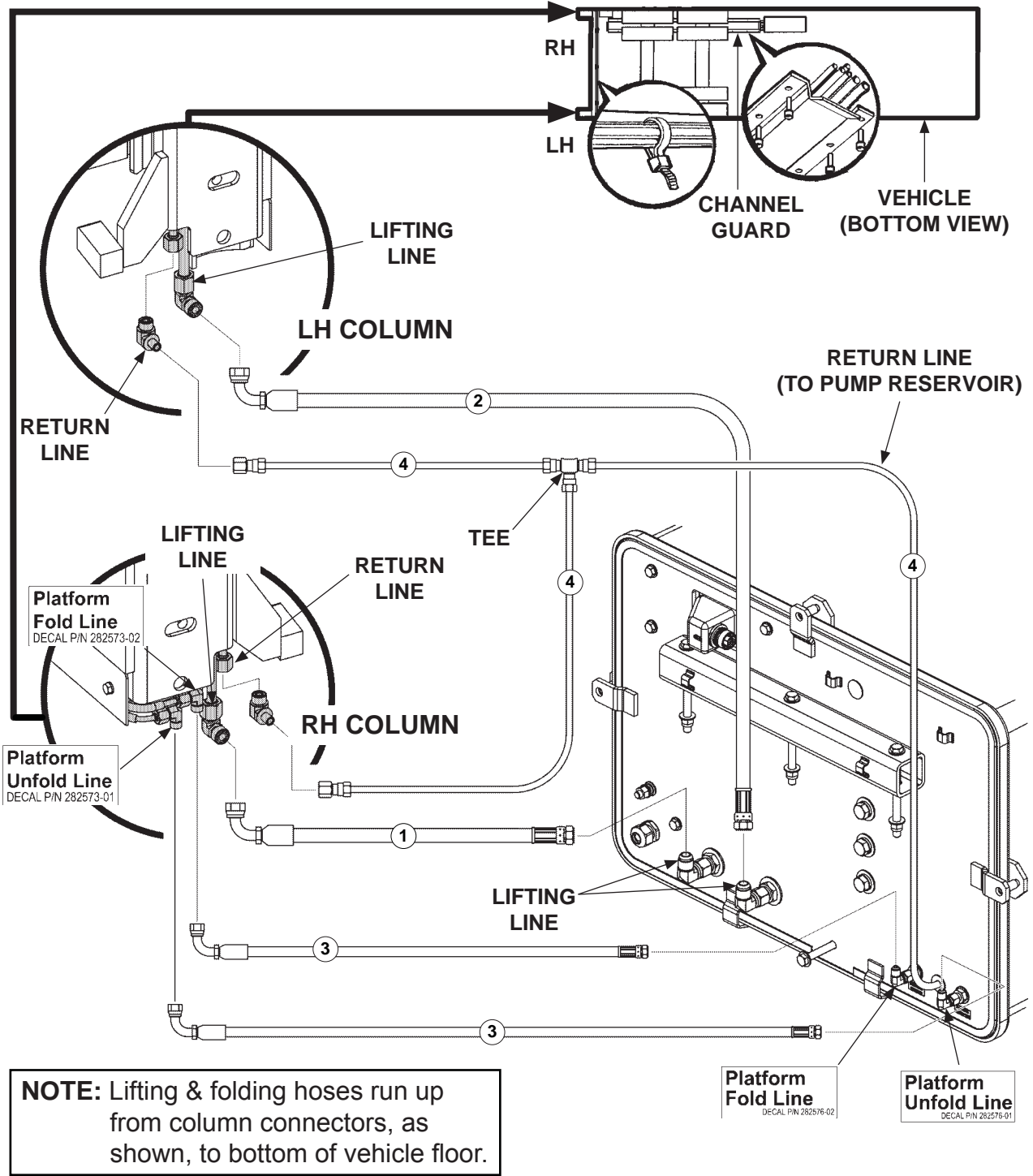

MAXON[®] 11921 Slauson Ave. Santa Fe Springs, CA. 90670 (800) 227-4116 FAX (888) 771-7713

FIG. 63-1

NOTE: Each pump extension kit contains 2 hoses of the same length (**item 3**). One hose is for the **Platform Fold Line** and the second hose is for the **Platform Unfold Line**. One hose has a yellow band on each connector to help connect the 2 hoses to the correct fittings. For example, connect hose with yellow bands to the **Fold Line** on the RH column and the **Fold Line** on the back of the pump box.

NOTE: For torque values for the hydraulic hose connectors, see **TABLES 66-1, 66-2 & 66-3**.

GRAVITY DOWN PUMP BOX INSTALLATION: REQUIRED HOSES & PLASTIC TUBING			
	3 FT.	10 FT.	15 FT.
1	HP 3/8" X 72" LG.	HP 3/8" X 196" LG.	HP 3/8" X 256" LG.
2	HP 3/8" X 150" LG.	HP 3/8" X 274" LG.	HP 3/8" X 334" LG.
3	HP 1/4" X 64" LG.	HP 1/4" X 188" LG.	HP 1/4" X 248" LG.
4	PLASTIC 3/8" OD X 84" LG.	PLASTIC 3/8" OD X 192" LG.	PLASTIC 3/8" OD X 264" LG.

TABLE 64-1

GRAVITY DOWN PUMP BOX INSTALLATION: REQUIRED HOSES & PLASTIC TUBING		
	20 FT.	28 FT.
1	HP 3/8" X 316" LG.	HP 3/8" X 412" LG.
2	HP 3/8" X 394" LG.	HP 3/8" X 490" LG.
3	HP 1/4" X 308" LG.	HP 1/4" X 404" LG.
4	PLASTIC 3/8" OD X 324" LG.	PLASTIC 3/8" OD X 420" LG.

TABLE 64-2

HYDRAULIC SYSTEM DIAGRAMS

TORQUE VALUES FOR HYDRAULIC CONNECTORS

SAE O-RING CONNECTORS

SIZE	TORQUE (LB-FT)	TORQUE (NEWTON-METER)
-4	13-15	17.6-20.3
-6	22-24	29.8-32.5
-8	40-43	54.2-58.3

TABLE 65-1

SAE 37 DEGREE FLARE CONNECTORS

SIZE	TORQUE (LB-FT)	TORQUE (NEWTON-METER)
-4	11-12	14.9-16.3
-6	18-20	24.4-27.1
-8	36-39	48.8-52.8

TABLE 65-2

O-RING FACE-SEAL CONNECTORS

SIZE	TORQUE (LB-FT)	TORQUE (NEWTON-METER)
-4	17-18	23-25.4
-6	25-27	33.9-37.3
-8	38-41	51.5-56.7

TABLE 65-3

POWER DOWN HYDRAULIC SCHEMATIC

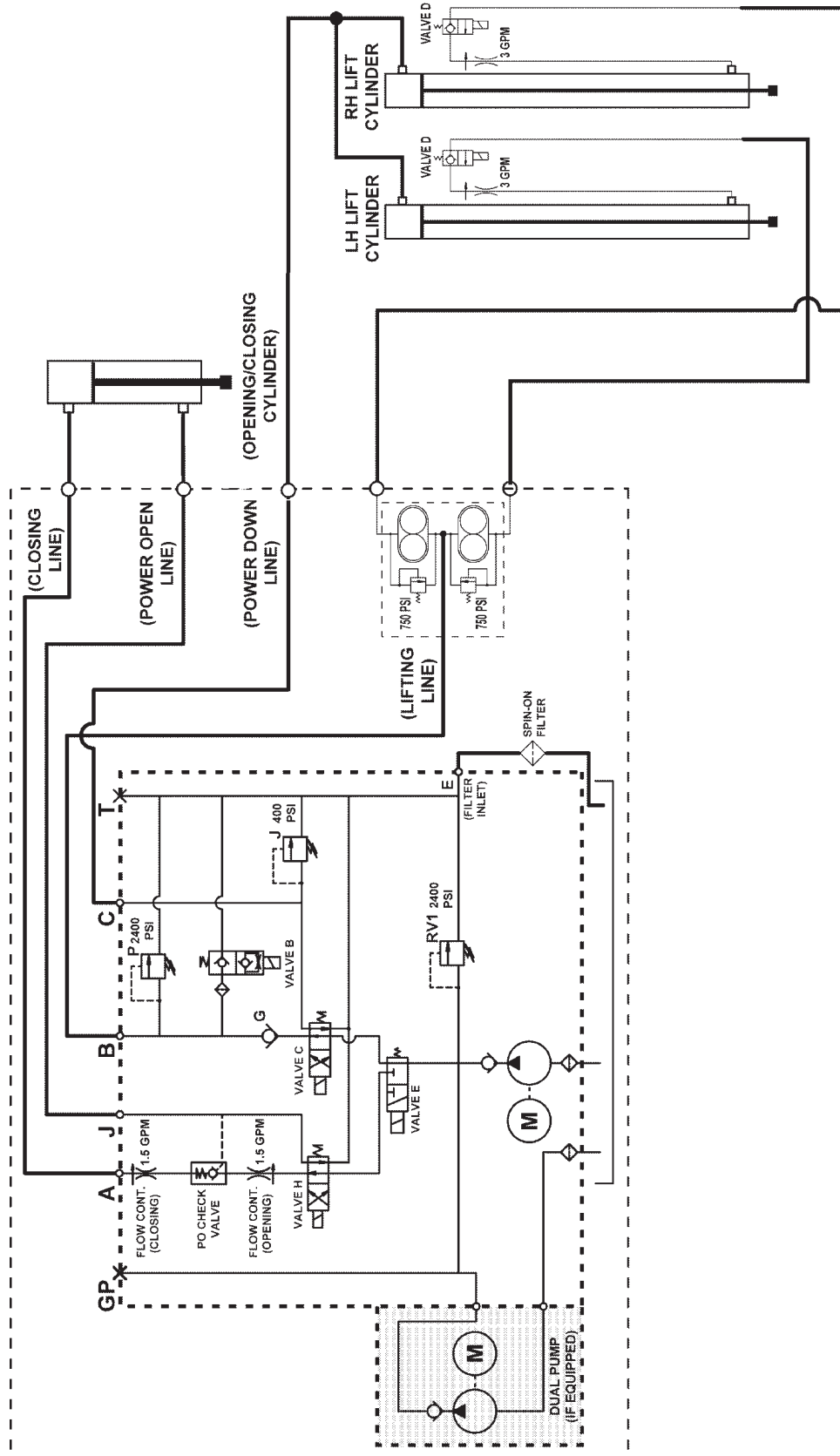

FIG. 66-1

HYDRAULIC SYSTEM DIAGRAMS

POWER DOWN HYDRAULIC LINES IDENTIFICATION

NOTE: See TABLES 65-1 & 65-2 for information on the numbered hoses in this illustration.

CAUTION
Before connecting hoses, ensure face seal o-rings are in place.

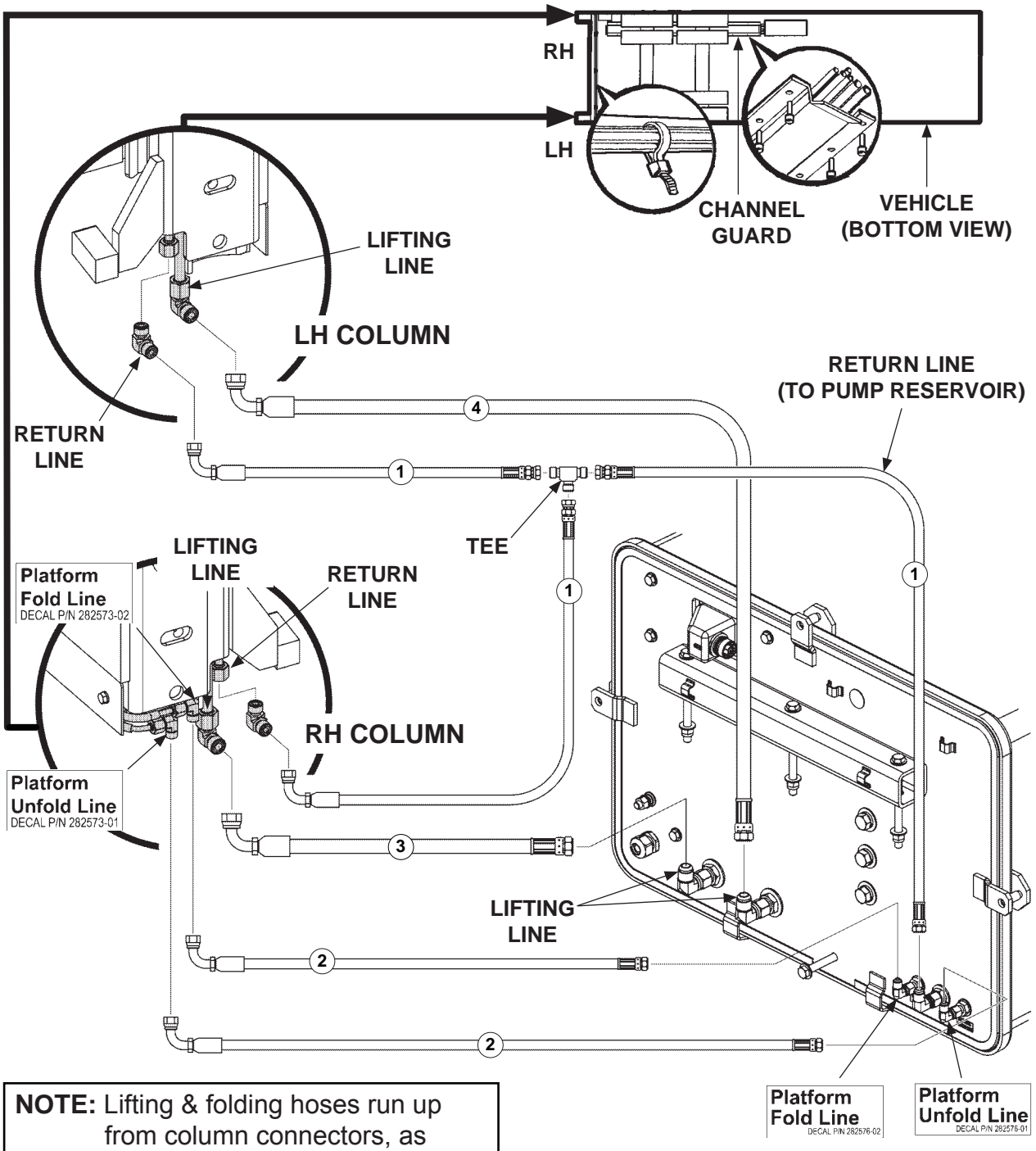

NOTE: Lifting & folding hoses run up from column connectors, as shown, to bottom of vehicle floor.

MAXON[®] 11921 Slauson Ave. Santa Fe Springs, CA. 90670 (800) 227-4116 FAX (888) 771-7713

FIG. 67-1

NOTE: Each pump extension kit contains 2 hoses of the same length (**item 1**). One hose is for the **Platform Fold Line** and the second hose is for the **Platform Unfold Line**. One hose has a yellow band on each connector to help connect the 2 hoses to the correct fittings. For example, connect hose with yellow bands to the **Fold Line** on the RH column and the **Fold Line** on the back of the pump box.

NOTE: See **TABLES 66-1, 66-2 & 66-3** for hydraulic fittings torque values.

POWER DOWN PUMP BOX INSTALLATION: REQUIRED HOSES			
	3 FT.	10 FT.	15 FT.
1	HP 1/4" X 34" LG.	HP 1/4" X 166" LG.	HP 1/4" X 226" LG.
2	HP 1/4" X 64" LG.	HP 1/4" X 188" LG.	HP 1/4" X 248" LG.
3	HP 3/8" X 72" LG.	HP 3/8" X 196" LG.	HP 3/8" X 256" LG.
4	HP 3/8" X 150" LG.	HP 3/8" X 274" LG.	HP 3/8" X 334" LG.

TABLE 68-1

POWER DOWN PUMP BOX INSTALLATION: REQUIRED HOSES		
	20 FT.	28 FT.
1	HP 1/4" X 286" LG.	HP 1/4" X 382" LG.
2	HP 1/4" X 308" LG.	HP 1/4" X 404" LG.
3	HP 3/8" X 316" LG.	HP 3/8" X 412" LG.
4	HP 3/8" X 394" LG.	HP 3/8" X 490" LG.

TABLE 68-2

ELECTRICAL SYSTEM DIAGRAMS

INTERCONNECTING ELECTRICAL SCHEMATIC - GRAVITY DOWN

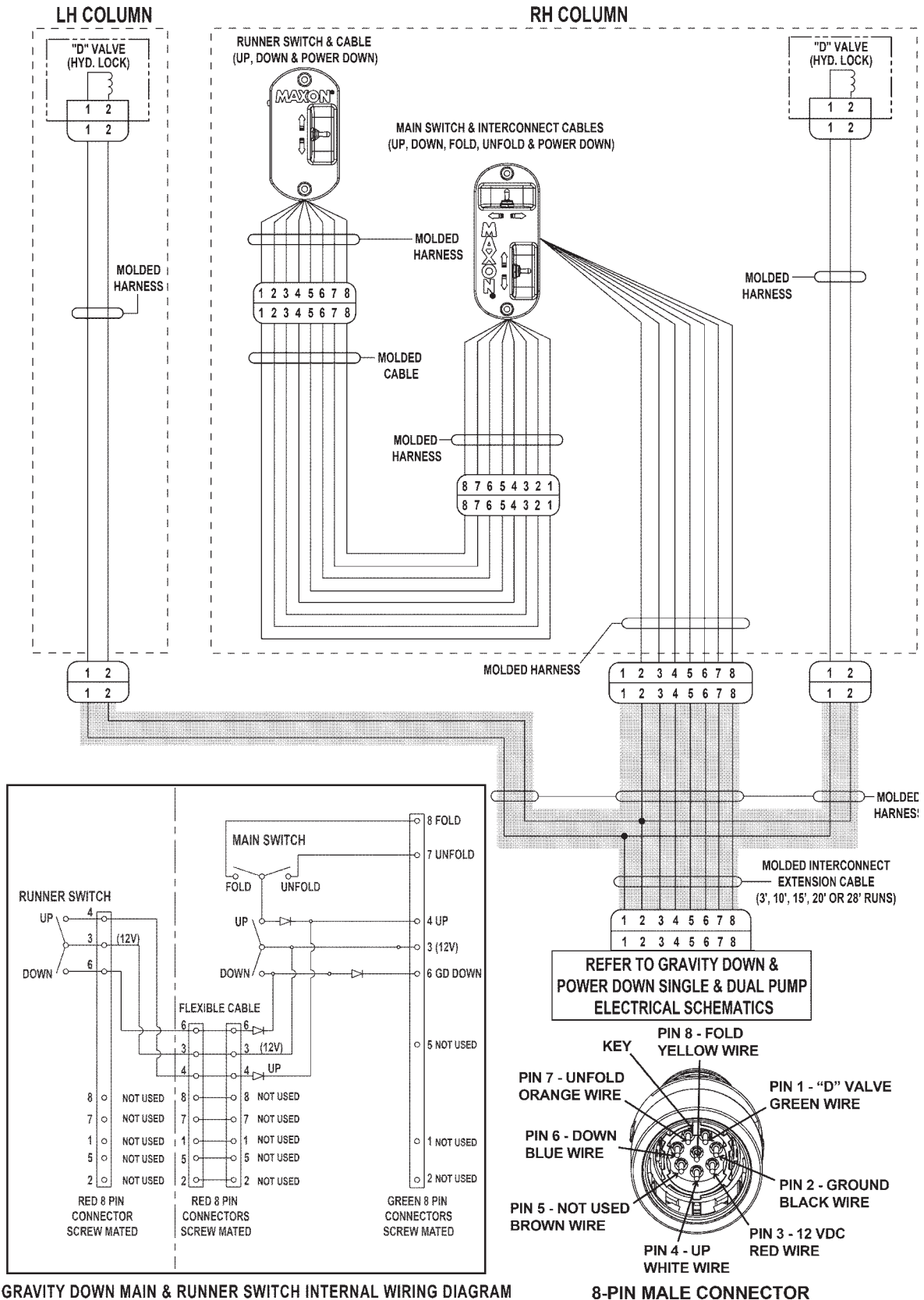

FIG. 69-1

GRAVITY DOWN SINGLE & DUAL PUMP ELECTRICAL SCHEMATIC

NOTE: Refer to **BMR ELECTRICAL VALUES** page.

MAXON

11921 Slauson Ave. Santa Fe Springs, CA. 90670 (800) 227-4116 FAX (888) 771-7713

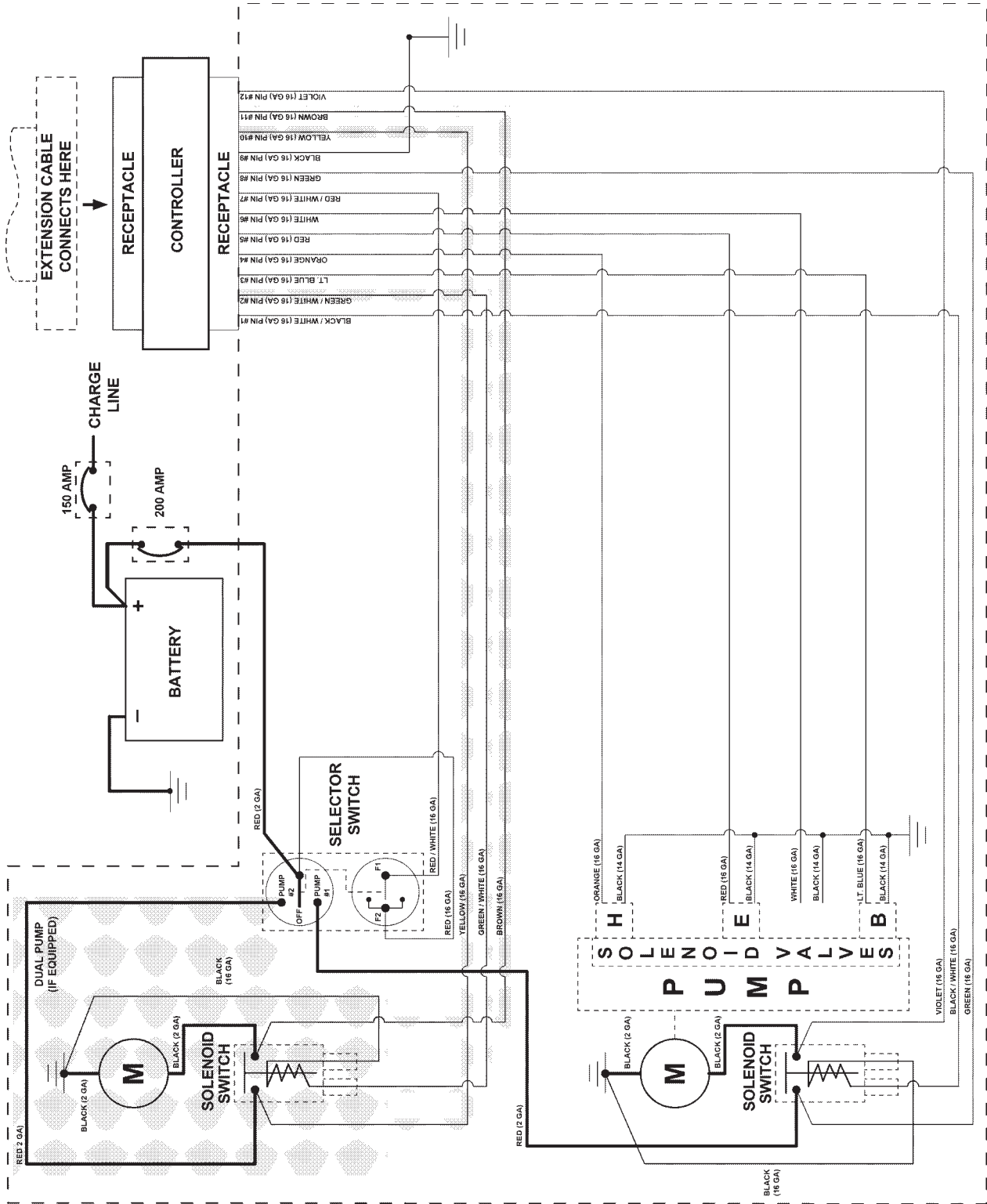

FIG. 70-1

POWER DOWN SINGLE & DUAL PUMP ELECTRICAL SCHEMATIC

NOTE: Refer to **BMR ELECTRICAL VALUES** page.

MAXON

11921 Slauson Ave. Santa Fe Springs, CA. 90670 (800) 227-4116 FAX (888) 771-7713

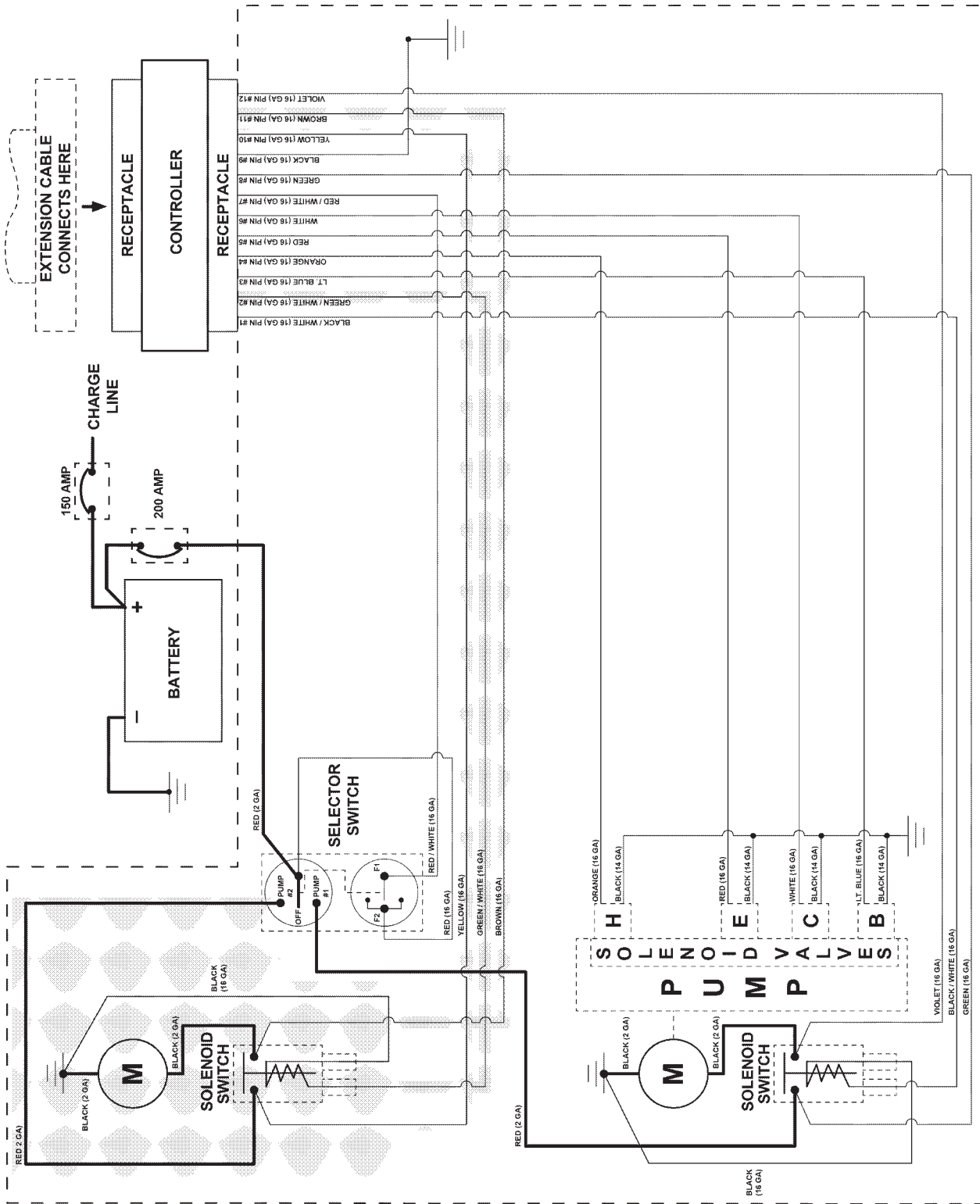

FIG. 72-1

ELECTRICAL SYSTEM DIAGRAMS - Continued

WIRING HARNESS TWIST-LOCK CONNECTORS

CAUTION

Before connecting, ensure connectors are clean inside. Apply thin coating of dielectric grease to face of receptacle to protect pins & sockets from corrosion. Avoid getting dielectric grease on connector contacts.

Refer to illustrations below for disconnecting, applying dielectric grease, and reconnecting twist-lock style connectors.

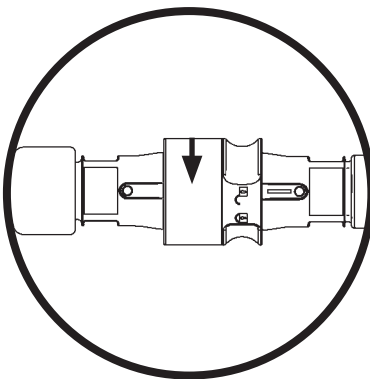

TWIST COUPLING RING TO UNLOCK
FIG. 73-1

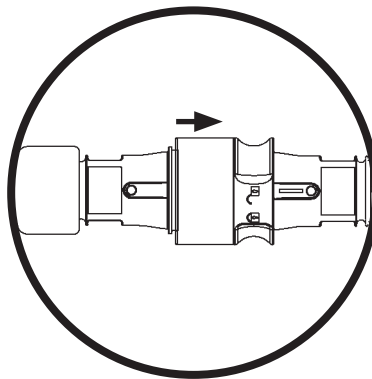

PULL COUPLING RING TO DISENGAGE
FIG. 73-2

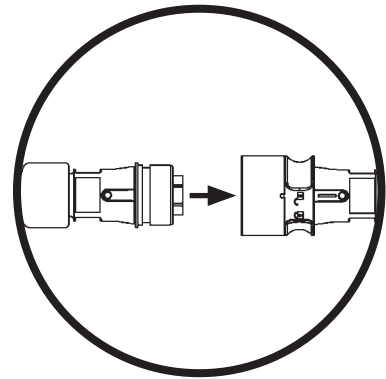

PULL CONNECTORS TO DISCONNECT
FIG. 73-3

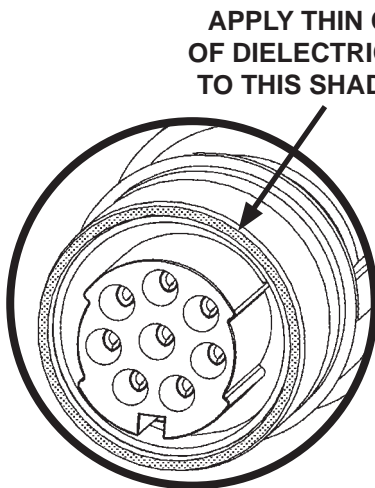

APPLY DIELECTRIC GREASE TO RECEPTACLE
FIG. 73-4

APPLY THIN COATING OF DIELECTRIC GREASE TO THIS SHADED AREA

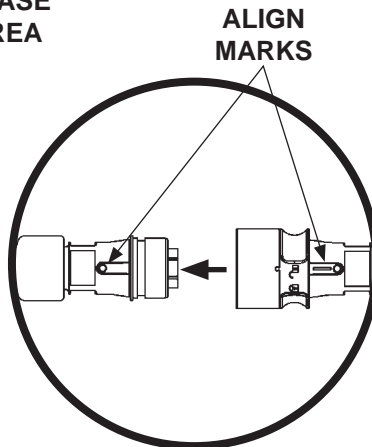

ALIGN & CONNECT
FIG. 73-5

ALIGN MARKS

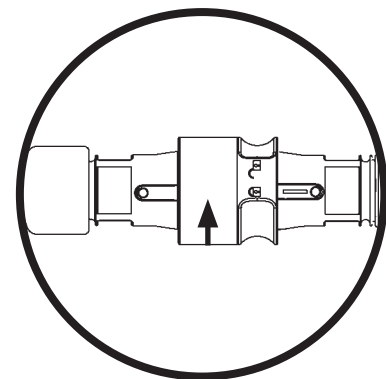

TWIST TO LOCK
FIG. 73-6

BMR-CS ELECTRICAL VALUES

MTE PUMP	BUCHER PUMP
Solenoid Switch: <ul style="list-style-type: none"> • Coil: 5.4Ω @ 70°F. ±15% • Ampere: 2.2A @ 12V • Coil terminal torque: 10-15 lb-in • Contact terminal torque: 30-35 lb-in 	Solenoid Switch: <ul style="list-style-type: none"> • Coil: 5.4Ω @ 70°F. ±15% • Ampere: 2.2A @ 12V • Coil terminal torque: 10-15 lb-in • Contact terminal torque: 30-35 lb-in
Solenoid Valves (H, E, and C): <ul style="list-style-type: none"> • Coil: 6.6Ω @ 70°F. ±15% • Ampere: 1.8A @ 12V • Coil nut torque: 15-45 lb-in 	Solenoid Valves (H, E, and C): <ul style="list-style-type: none"> • Coil: 4.0Ω @ 70°F. ±15% • Ampere: 2.5A @ 10V • Coil nut torque: 15-45 lb-in
Solenoid Valve (B): <ul style="list-style-type: none"> • Coil: 7.5Ω @ 70°F. ±15% • Ampere: 1.6A @ 12V • Coil nut torque: 15-45 lb-in 	Solenoid Valve (B): <ul style="list-style-type: none"> • Coil: 4.0Ω @ 70°F. ±15% • Ampere: 2.5A @ 10V • Coil nut torque: 15-45 lb-in
H, E, C & B Valve Cartridge Torque: 25-30 lb-ft maximum <ul style="list-style-type: none"> • Coil nut torque: 15-45 lb-in 	H, E, C & B Valve Cartridge Torque: 25-30 lb-ft maximum <ul style="list-style-type: none"> • Coil nut torque: 15-45 lb-in
Solenoid Valve (D): <ul style="list-style-type: none"> • Coil: 8.0Ω @ 70°F. ±15% • Ampere: 1.5A @ 12V • Coil nut torque: 3-4.5 lb-ft • Valve cartridge torque: 18.5-22 lb-ft 	Solenoid Valve (D): <ul style="list-style-type: none"> • Coil: 8.0Ω @ 70°F. ±15% • Ampere: 1.5A @ 12V • Coil nut torque: 3-4.5 lb-ft • Valve cartridge torque: 18.5-22 lb-ft
Pump Selector Switch Terminal Stud Torque: 140 lb-in maximum	Pump Selector Switch Terminal Stud Torque: 140 lb-in maximum
Cable Ground Stud Torque: 24 lb-ft maximum	Cable Ground Stud Torque: 24 lb-ft maximum

TABLE 74-1

TROUBLESHOOTING

PLATFORM WILL NOT RAISE & MOTOR WILL NOT RUN (MTE PUMP)

NOTE: For dual pump system, check secondary pump and motor first.

1. Check for 12.6 volts DC input to starter solenoid by using voltmeter between terminal B (**FIG. 75-1**) and ground. If there is no power to the motor solenoid, make sure pump box master disconnect switch is **ON** and circuit breaker is set.

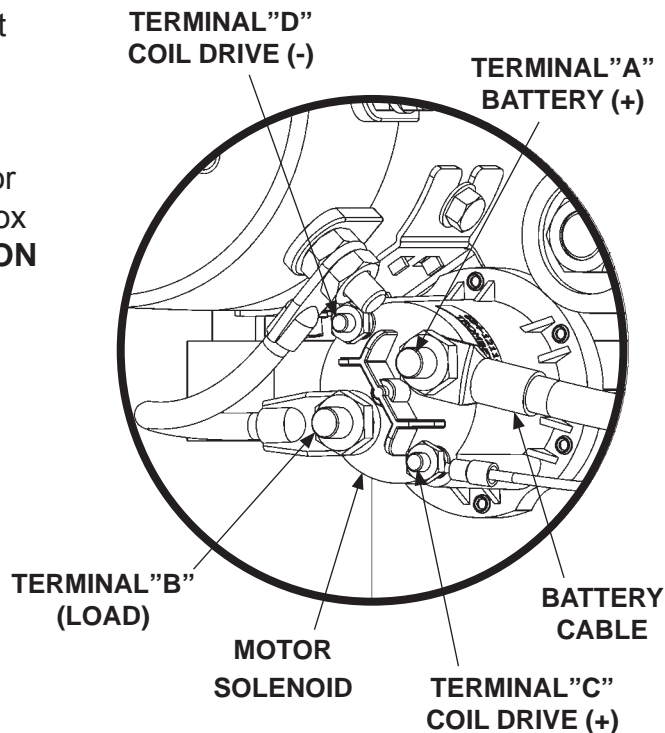

**TYPICAL MOTOR SOLENOID ELECTRICAL CONNECTIONS
(POWER DOWN PUMP IS SHOWN)
FIG. 75-1**

2. Find out if vehicle is equipped with optional battery box, truck charge line, tractor charge line, or trailer charge line. Check optional battery box cables and charge line cables for damage, dirty connections and loose connections. Replace damaged battery cables, clean dirty connections, and tighten loose connections.
3. Check if vehicle batteries and optional battery box batteries are fully charged. If required, fully charge batteries with a battery charger. Replace batteries that cannot be fully charged. If battery charger fully charges batteries, use vehicle manufacturer's specifications to check the vehicle battery charging system. Do not operate Liftgate if vehicle charging system needs repair.
4. Use a 6" long, 10 gauge insulated wire as a jumper to connect starter solenoid terminal A and terminal C. Check for 12.6 volts DC output from starter solenoid by using voltmeter between terminal B (**FIG. 75-1**) and ground. If a low voltage or 0 volts is indicated on terminal B, replace starter solenoid. Also, check electrical cable to motor for damage, dirty connections, and loose connections. Replace damaged electrical cable to motor, clean dirty connections, and tighten loose connections. If necessary, use multimeter and applicable electrical schematics in this manual to check switch controls and interconnecting wiring.

TROUBLESHOOTING

PLATFORM WILL NOT RAISE & MOTOR WILL NOT RUN (BUCHER PUMP)

NOTE: For dual pump system, check secondary pump and motor first.

1. Check for 12.6 volts DC input to starter solenoid by using voltmeter between terminal B (**FIG. 76-1**) and ground. If there is no power to the motor solenoid, make sure pump box master disconnect switch is **ON** and circuit breaker is set.

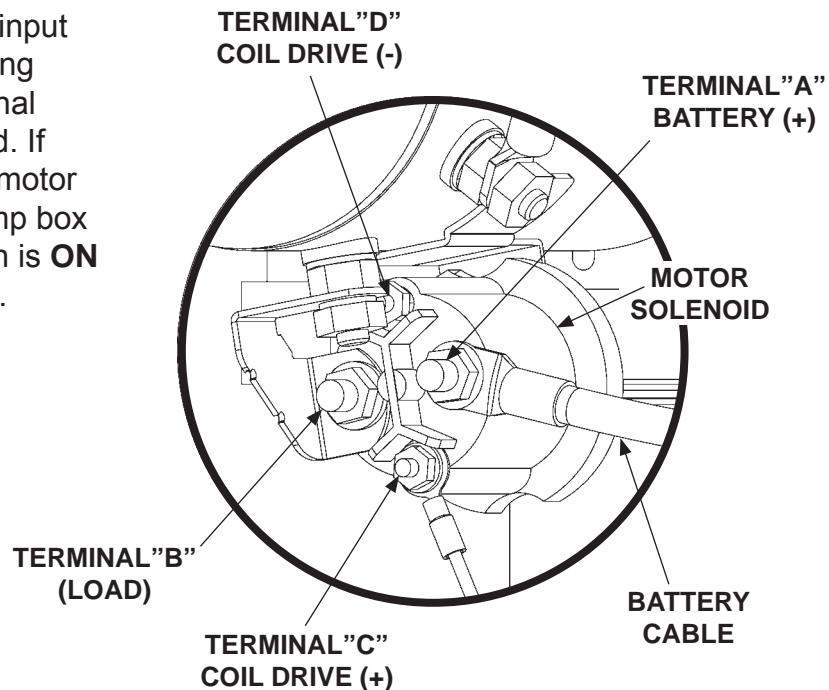

**TYPICAL MOTOR SOLENOID ELECTRICAL CONNECTIONS
(POWER DOWN PUMP IS SHOWN)
FIG. 76-1**

2. Find out if vehicle is equipped with optional battery box, truck charge line, tractor charge line, or trailer charge line. Check optional battery box cables and charge line cables for damage, dirty connections and loose connections. Replace damaged battery cables, clean dirty connections, and tighten loose connections.
3. Check if vehicle batteries and optional battery box batteries are fully charged. If required, fully charge batteries with a battery charger. Replace batteries that cannot be fully charged. If battery charger fully charges batteries, use vehicle manufacturer's specifications to check the vehicle battery charging system. Do not operate Liftgate if vehicle charging system needs repair.
4. Use a 6" long, 10 gauge insulated wire as a jumper to connect starter solenoid terminal A and terminal C. Check for 12.6 volts DC output from starter solenoid by using voltmeter between terminal B (**FIG. 76-1**) and ground. If a low voltage or 0 volts is indicated on terminal B, replace starter solenoid. Also, check electrical cable to motor for damage, dirty connections, and loose connections. Replace damaged electrical cable to motor, clean dirty connections, and tighten loose connections. If necessary, use multimeter and applicable electrical schematics in this manual to check switch controls and interconnecting wiring.

TROUBLESHOOTING

PLATFORM WILL NOT RAISE & MOTOR RUNS (MTE PUMP)

1. Check the hydraulic fluid level in the reservoir. Refer to the **CHECKING HYDRAULIC FLUID** procedure in this manual.

NOTE: For dual pump system, check secondary pump and motor first.

NOTE: Numbers for the electrical terminals shown in the illustration are not stamped on valve coil. Numbers shown are for reference only.

2. Try raising platform (activate **UP** toggle switch). Only the motor solenoid (**FIG. 77-1**) should be energized while raising platform. Refer to **HYDRAULIC SYSTEM DIAGRAMS** in this manual. Connect voltmeter to Terminal-1 and Terminal-2 on each valve shown in **FIGS. 77-1 and 77-1A**. Correct indication is 0 volts DC. If voltmeter indicates +11 to +12.6 volts DC for any of the valves, check control switch and wiring to the valve. Refer to the **DUAL PUMP BOX** or **SINGLE PUMP BOX ELECTRICAL SCHEMATIC**. Replace faulty wiring or control switch as required.

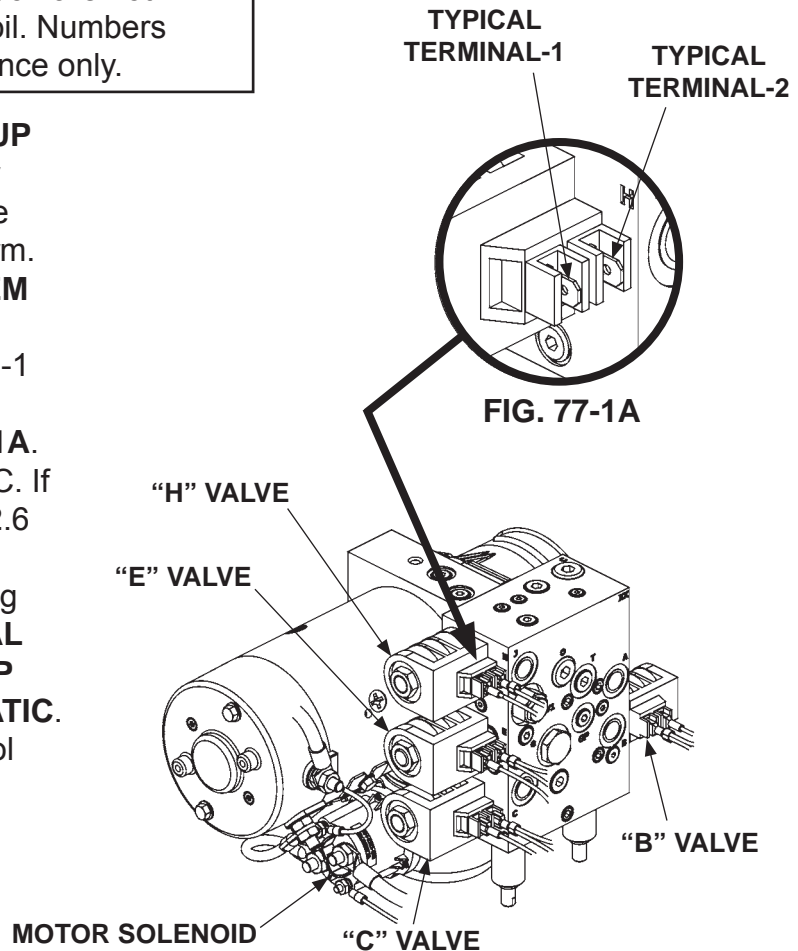

**POWER DOWN PUMP/MOTOR VALVES & ELECTRICAL CONNECTIONS
(POWER DOWN PUMP IS SHOWN)**

FIG. 77-1

⚠ WARNING

Make sure Liftgate platform is open and resting on the ground before performing the following step.

CAUTION

To prevent damage when installing valve cartridges & coils, torque valve cartridge to 25-30 lb-ft and coil nut to 15-45 lb-in.

3. The “E” solenoid valve (**FIG. 78-1**) may be stuck in the “open” position. Remove the “E” solenoid valve (**FIG. 78-1**). Next, check the valve cartridge as follows. Push on the plunger in the valve by inserting a small screwdriver in the open end (**FIG. 78-2**). If the plunger does not move with a smooth, spring-loaded action (approximately 1/8”) (**FIG. 78-2**), replace the valve cartridge.

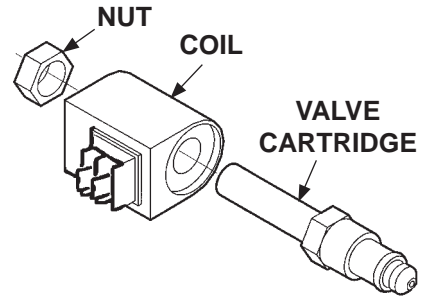

**TYPICAL SOLENOID VALVE
REMOVED & DISASSEMBLED
FIG. 78-1**

4. Reinstall “E” solenoid valve (if good) or a replacement. **Torque valve cartridge to 25-30 lb-ft and coil nut to 15-45 lb-in.**

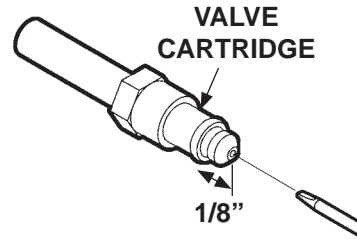

**CHECKING VALVE CARTRIDGE
FIG. 78-2**

5. Check for bent and broken parts on the Liftgate that could interfere with normal operation.

MAXON[®]

11921 Slauson Ave. Santa Fe Springs, CA. 90670 (800) 227-4116 FAX (888) 771-7713

TROUBLESHOOTING

PLATFORM WILL NOT RAISE & MOTOR RUNS (BUCHER PUMP)

1. Check the hydraulic fluid level in the reservoir. Refer to the **CHECKING HYDRAULIC FLUID** procedure in this manual.

NOTE: For dual pump system, check secondary pump and motor first.

NOTE: Numbers for the electrical terminals shown in the illustration are not stamped on valve coil. Numbers shown are for reference only.

2. Try raising platform (activate **UP** toggle switch). Only the motor solenoid (**FIG. 79-1**) should be energized while raising platform. Refer to **HYDRAULIC SYSTEM DIAGRAMS** in this manual. Connect voltmeter to Terminal-1 and Terminal-2 on each valve shown in **FIGS. 79-1 and 79-1A**. Correct indication is 0 volts DC. If voltmeter indicates +11 to +12.6 volts DC for any of the valves, check control switch and wiring to the valve. Refer to the **DUAL PUMP BOX** or **SINGLE PUMP BOX ELECTRICAL SCHEMATIC**. Replace faulty wiring or control switch as required.

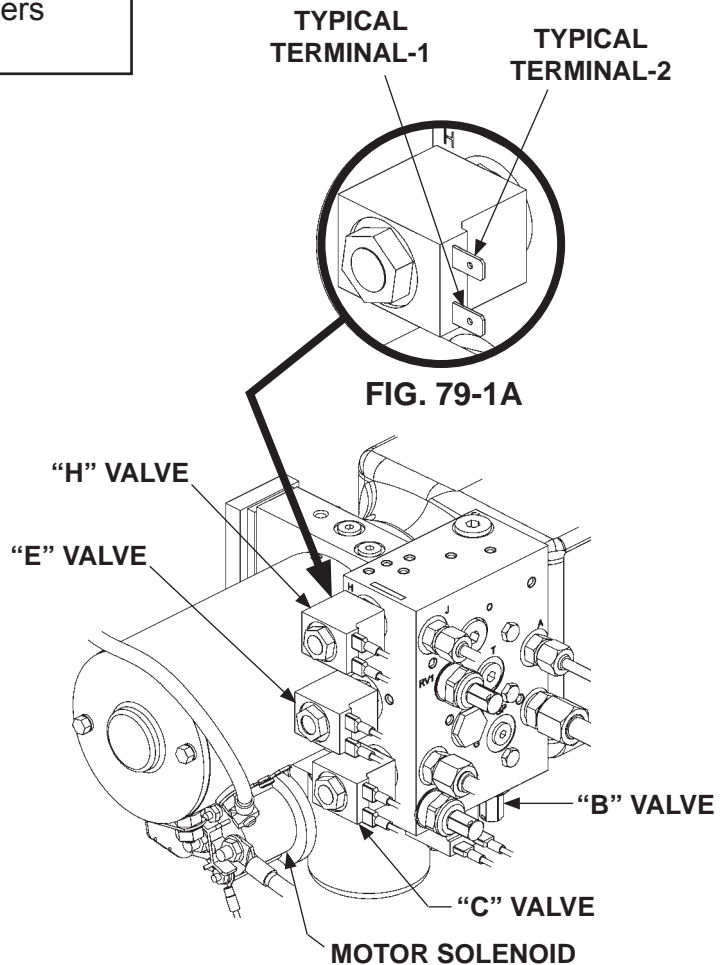

POWER DOWN PUMP/MOTOR VALVES & ELECTRICAL CONNECTIONS (POWER DOWN PUMP IS SHOWN)
FIG. 79-1

⚠ WARNING

Make sure Liftgate platform is open and resting on the ground before performing the following step.

CAUTION

To prevent damage when installing valve cartridges & coils, torque valve cartridge to 25-30 lb-ft and coil nut to 15-45 lb-in.

3. The “E” solenoid valve (**FIG. 80-1**) may be stuck in the “open” position. Remove the “E” solenoid valve (**FIG. 80-1**). Next, check the valve cartridge as follows. Push on the plunger in the valve by inserting a small screwdriver in the open end (**FIG. 80-2**). If the plunger does not move with a smooth, spring-loaded action (approximately 1/8”) (**FIG. 80-2**), replace the valve cartridge.

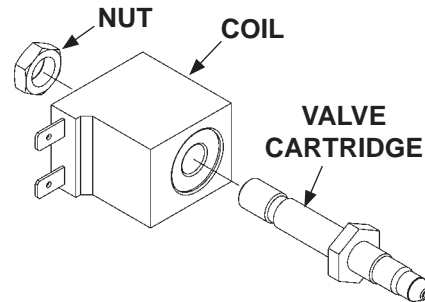

**TYPICAL SOLENOID VALVE
REMOVED & DISASSEMBLED
FIG. 80-1**

4. Reinstall “E” solenoid valve (if good) or a replacement. **Torque valve cartridge to 25-30 lb-ft and coil nut to 15-45 lb-in.**

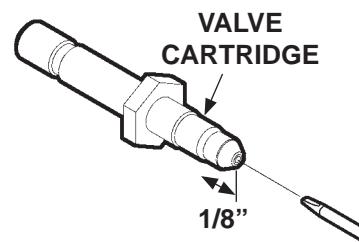

**CHECKING VALVE CARTRIDGE
FIG. 80-2**

5. Check for bent and broken parts on the Liftgate that could interfere with normal operation.

TROUBLESHOOTING

PLATFORM WILL NOT RAISE LOAD AT RATED CAPACITY (MTE PUMP)

⚠ WARNING

To prevent possible injury and equipment damage, ensure platform is supported before disconnecting hydraulic lines.

1. Check for unequal cylinder operation (lagging cylinder first) as follows.

Unfold the platform and raise to vehicle bed height. Disconnect **POWER DOWN** hose from hydraulic line at the bottom of RH column. Place a 3 gallon bucket under column to catch fluid from the open lines. Set control box toggle switch to **UP** position. Check if fluid is streaming from the open hydraulic line. A few drops of hydraulic fluid is okay; however, if fluid streams steadily from a line, replace piston seals in the cylinder connected to that line. Repeat this step for the LH column.

2. Check vehicle charge line cables for damage, dirty connections and loose connections. If Liftgate battery box is installed, check for damaged battery cables, dirty cable connections and loose cable connections in battery box. Replace damaged cables, clean dirty connections and tighten loose connections.
3. Check for bent parts on the Liftgate that could interfere with normal operation.

4. Verify that relief valve pressure settings are correct. Refer to **LIFTING LINE RELIEF VALVE PRESSURE SETTING** procedure. If pressure settings cannot be corrected or if pump runs hot with excessive noise, replace pump.

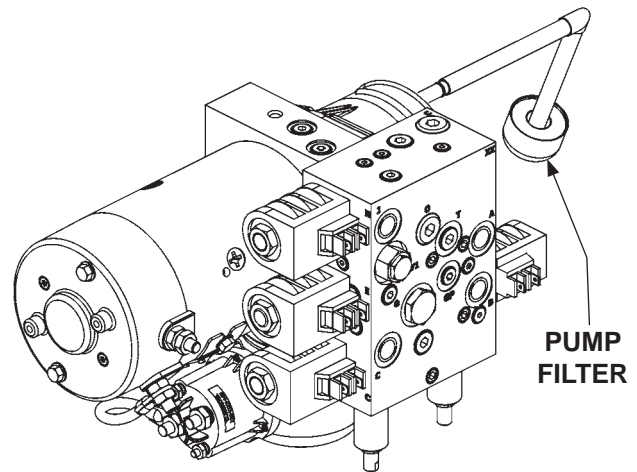

SPIN-ON FILTER
FIG. 81-1

NOTE: Do the **BLEEDING HYDRAULIC SYSTEM** procedure in this manual after doing the following step.

5. Remove pump/motor assembly from reservoir (**FIG. 81-1**). Check if pump filter is clogged. If clogged, clean filter and flush contaminated fluid from reservoir. Replace spin-on filter in pump box. Reinstall pump/motor assembly.

TROUBLESHOOTING PLATFORM WILL NOT RAISE LOAD AT RATED CAPACITY (BUCHER PUMP)

⚠ WARNING

To prevent possible injury and equipment damage, ensure platform is supported before disconnecting hydraulic lines.

1. Check for unequal cylinder operation (lagging cylinder first) as follows.

Unfold the platform and raise to vehicle bed height. Disconnect **POWER DOWN** hose from hydraulic line at the bottom of RH column. Place a 3 gallon bucket under column to catch fluid from the open lines. Set control box toggle switch to **UP** position. Check if fluid is streaming from the open hydraulic line. A few drops of hydraulic fluid is okay; however, if fluid streams steadily from a line, replace piston seals in the cylinder connected to that line. Repeat this step for the LH column.

2. Check vehicle charge line cables for damage, dirty connections and loose connections. If Liftgate battery box is installed, check for damaged battery cables, dirty cable connections and loose cable connections in battery box. Replace damaged cables, clean dirty connections and tighten loose connections.

3. Check for bent parts on the Liftgate that could interfere with normal operation.

4. Verify that relief valve pressure settings are correct. Refer to **LIFTING LINE RELIEF VALVE PRESSURE SETTING** procedure. If pressure settings cannot be corrected or if pump runs hot with excessive noise, replace pump.

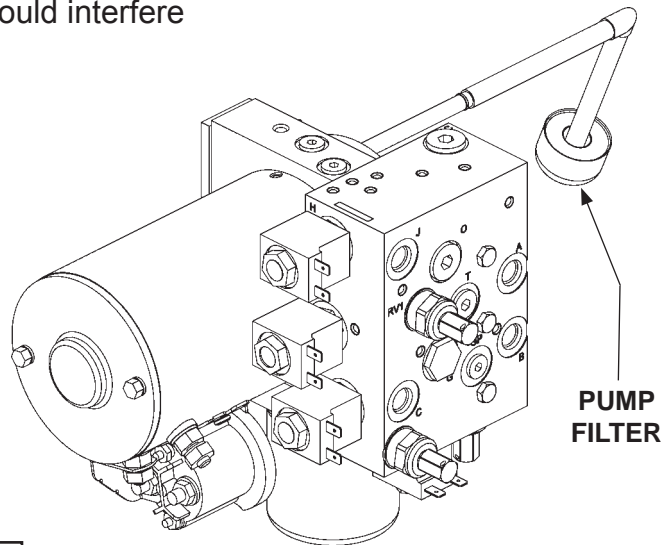

**SPIN-ON FILTER
FIG. 82-1**

NOTE: Do the **BLEEDING HYDRAULIC SYSTEM** procedure in this manual after doing the following step.

5. Remove pump/motor assembly from reservoir (**FIG. 82-1**). Check if pump filter is clogged. If clogged, clean filter and flush contaminated fluid from reservoir. Replace spin-on filter in pump box. Reinstall pump/motor assembly.

TROUBLESHOOTING

PLATFORM RAISES AND LOWERS UNEVENLY

⚠ WARNING

To prevent possible injury and equipment damage, ensure platform is supported before disconnecting hydraulic lines.

NOTE: Do the **BLEEDING HYDRAULIC SYSTEM** procedure in this manual after any hydraulic hoses & flow control valves are disconnected and reconnected.

1. Unfold the platform and lower to the ground.
2. Reverse the two 3/8" high pressure hose connections on output side of flow divider as shown in **FIG. 83-1**. Raise the platform. If the uneven platform position is the opposite of original symptom, replace flow divider.

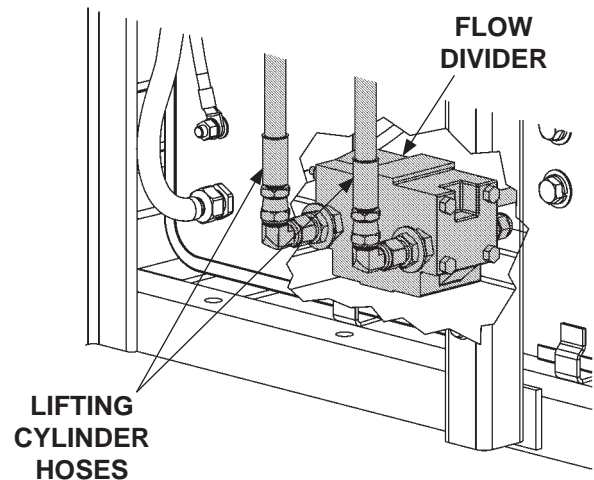

**HOSE CONNECTIONS ON
FLOW DIVIDER
FIG. 83-1**

NOTE: When platform is being raised or lowered, 1" maximum distance from side to side is acceptable.

3. Check for unequal cylinder operation (lagging cylinder first) as follows.
 - **GRAVITY DOWN LIFTGATES:** Lower the platform to the ground. Disconnect the RETURN HOSE at the bottom of each column. Place a large container under cylinder to catch fluid. Set control box toggle switch to **UP** position to raise platform. Check if fluid is streaming from the fitting. A few drops of hydraulic fluid is okay; however, if fluid streams steadily from the fitting, replace piston seals.
 - **POWER DOWN LIFTGATES:** Raise the platform to bed height. Disconnect both bottom **POWER DOWN RETURN HOSES** at the "T" connector between pump box and bottom of each cylinder. (**Refer to POWER DOWN HYDRAULIC LINES IDENTIFICATION in this manual**). Place a large container to catch fluid from both hoses. Set control box toggle switch to **UP** position to raise platform. Check if fluid is streaming from the hoses. A few drops of hydraulic fluid is okay; however, if fluid streams steadily from a hose, replace piston seals in the cylinder connected to that hose.

4. Lower the platform to the ground and remove the flow control valve (**FIG. 84-1**) at the top of each column. Check if flow control valves are contaminated. Try to move plunger with a small screwdriver. If necessary, clean the valve (**FIG. 84-1**). Reinstall clean flow control valve or replace if necessary.
5. Check for bent parts on the Liftgate that could interfere with normal operation.

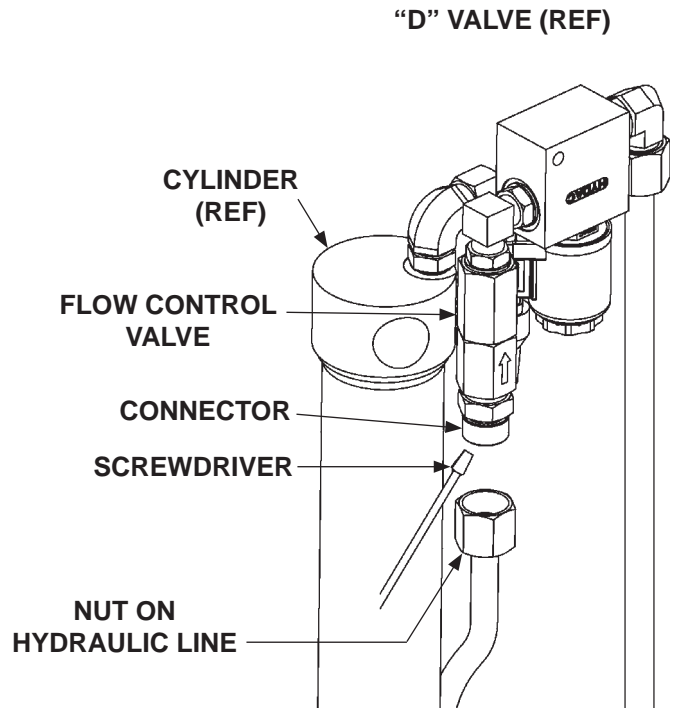
**FIG. 84-1**

TROUBLESHOOTING

PLATFORM RAISES HALFWAY & STOPS (MTE PUMP)

1. Check the hydraulic fluid level in the reservoir.

- **GRAVITY DOWN LIFTGATES:** Lower the platform to the ground. Clean dirt and fluid from top of reservoir in pump box. Fill the reservoir to correct level indicated on sight glass (pump box).
- **POWER DOWN LIFTGATES:** Raise the platform to bed height. Fill the reservoir to correct level indicated on sight glass (pump box).

NOTE: For dual pump system, check secondary pump and motor first.

2. Find out if vehicle is equipped with optional battery box, truck charge line, tractor charge line, or trailer charge line. Check optional battery box cables and charge line cables for damage, dirty connections and loose connections. Replace damaged battery cables, clean dirty connections, and tighten loose connections.
3. Check if vehicle batteries and optional battery box batteries are fully charged. If required, fully charge batteries with a battery charger. Replace batteries that cannot fully charge. If battery charger fully charges batteries, use vehicle manufacturer's specifications to check the vehicle battery charging system. Do not operate Liftgate if vehicle charging system needs repair.

4. Check pump motor solenoid (**FIG. 85-1**) and electrical cable connections in pump box. Make sure electrical cable connections are clean and tight. Use a 6" long, 10 gauge insulated wire as a jumper between motor solenoid terminals "A" and "C" to activate solenoid. Replace solenoid if it fails to activate.

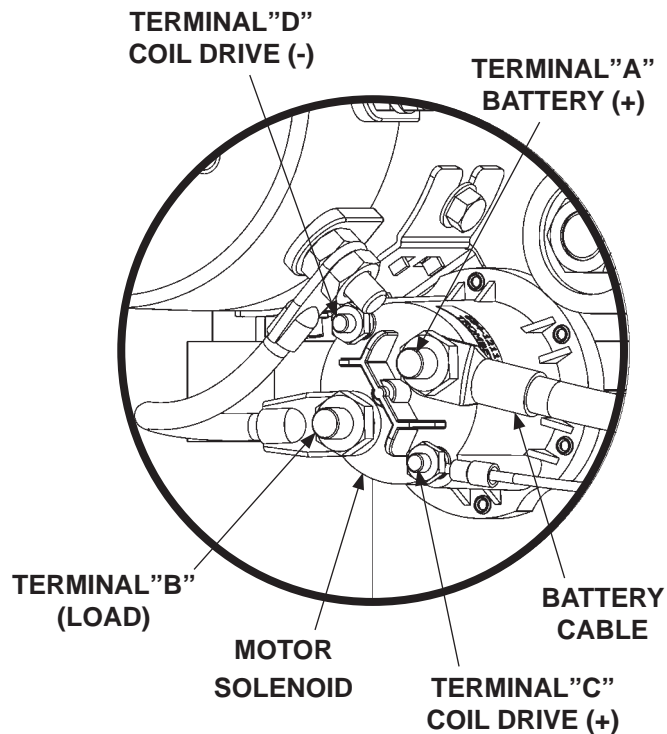

**TYPICAL MOTOR SOLENOID ELECTRICAL CONNECTIONS
(POWER DOWN PUMP IS SHOWN)
FIG. 85-1**

5. Check for bent parts on the Liftgate that could interfere with normal operation.

NOTE: Do the **BLEEDING HYDRAULIC SYSTEM** procedure in this manual with the following step.

6. Remove assembled pump and motor from reservoir (**FIG. 86-1**). Check if pump filter is clogged. Clean clogged filter and flush contaminated fluid from reservoir. Replace spin-on filter in pump box.

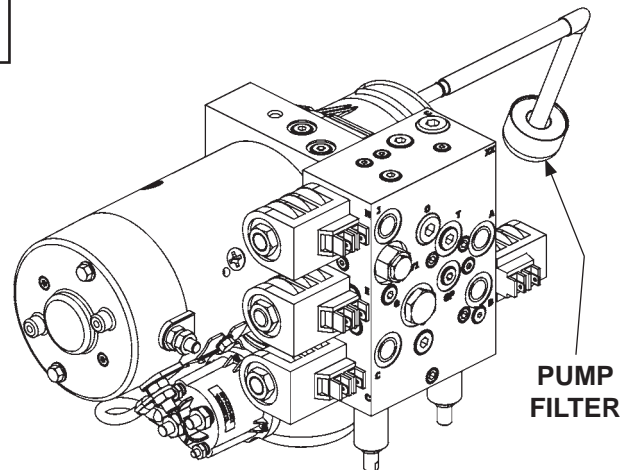

SPIN-ON FILTER
FIG. 86-1

7. If pump runs hot and extremely noisy, replace it.

NOTE: Do the **BLEEDING HYDRAULIC SYSTEM** procedure in this manual with the following step.

8. At the top of each column, loosen nut and disconnect hydraulic line from connector on bottom of flow control valve (**FIG. 86-2**). Check if the flow control valves are contaminated. Try to move plunger with small screwdriver through bottom of connector (**FIG. 86-2**). Replace valve if contaminated or not working.

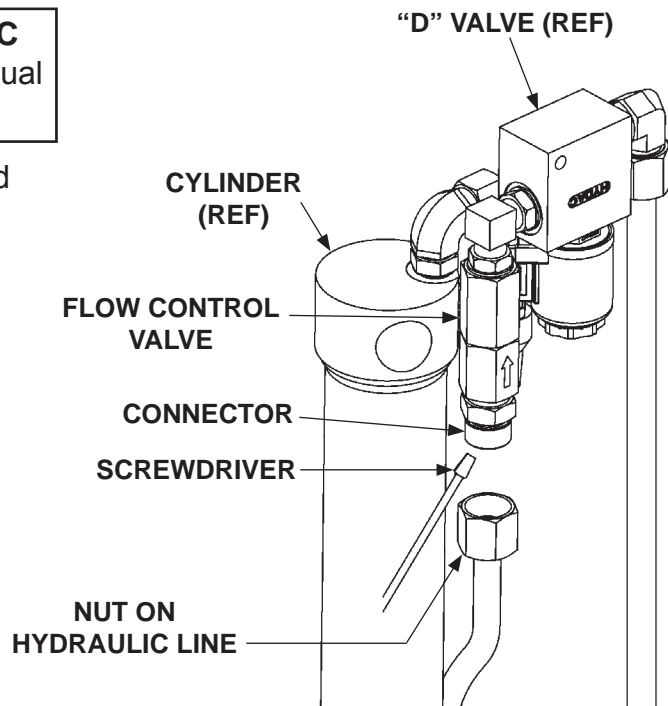

FIG. 86-2

TROUBLESHOOTING

PLATFORM RAISES HALFWAY & STOPS (BUCHER PUMP)

1. Check the hydraulic fluid level in the reservoir.

- **GRAVITY DOWN LIFTGATES:** Lower the platform to the ground. Clean dirt and fluid from top of reservoir in pump box. Fill the reservoir to correct level indicated on sight glass (pump box).
- **POWER DOWN LIFTGATES:** Raise the platform to bed height. Fill the reservoir to correct level indicated on sight glass (pump box).

NOTE: For dual pump system, check secondary pump and motor first.

2. Find out if vehicle is equipped with optional battery box, truck charge line, tractor charge line, or trailer charge line. Check optional battery box cables and charge line cables for damage, dirty connections and loose connections. Replace damaged battery cables, clean dirty connections, and tighten loose connections.
3. Check if vehicle batteries and optional battery box batteries are fully charged. If required, fully charge batteries with a battery charger. Replace batteries that cannot fully charge. If battery charger fully charges batteries, use vehicle manufacturer's specifications to check the vehicle battery charging system. Do not operate Liftgate if vehicle charging system needs repair.

4. Check pump motor solenoid (**FIG. 87-1**) and electrical cable connections in pump box. Make sure electrical cable connections are clean and tight. Use a 6" long, 10 gauge insulated wire as a jumper between motor solenoid terminals "A" and "C" to activate solenoid. Replace solenoid if it fails to activate.

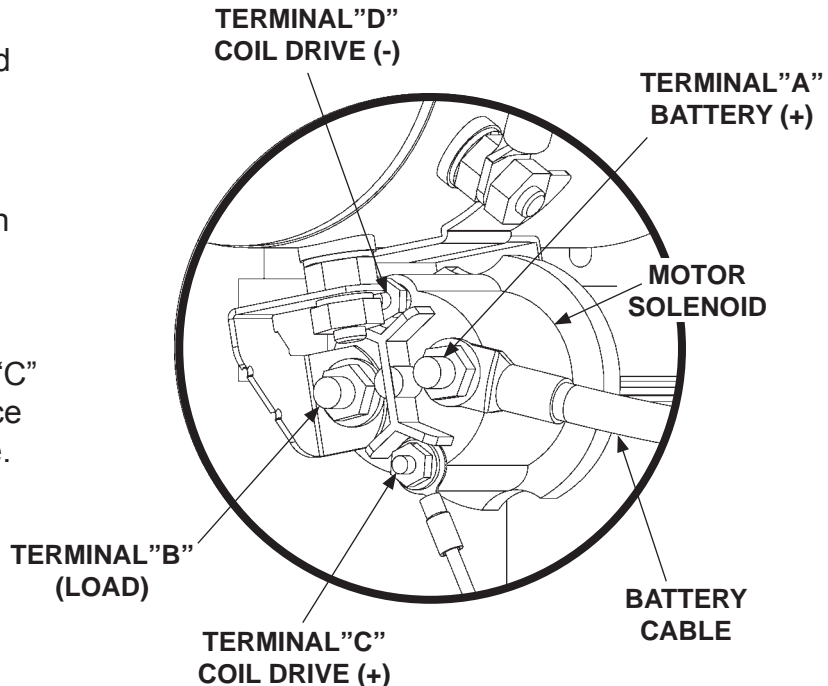

**TYPICAL MOTOR SOLENOID ELECTRICAL CONNECTIONS
(POWER DOWN PUMP IS SHOWN)**

FIG. 87-1

5. Check for bent parts on the Liftgate that could interfere with normal operation.

NOTE: Do the **BLEEDING HYDRAULIC SYSTEM** procedure in this manual with the following step.

6. Remove assembled pump and motor from reservoir (**FIG. 88-1**). Check if pump filter is clogged. Clean clogged filter and flush contaminated fluid from reservoir. Replace spin-on filter in pump box.

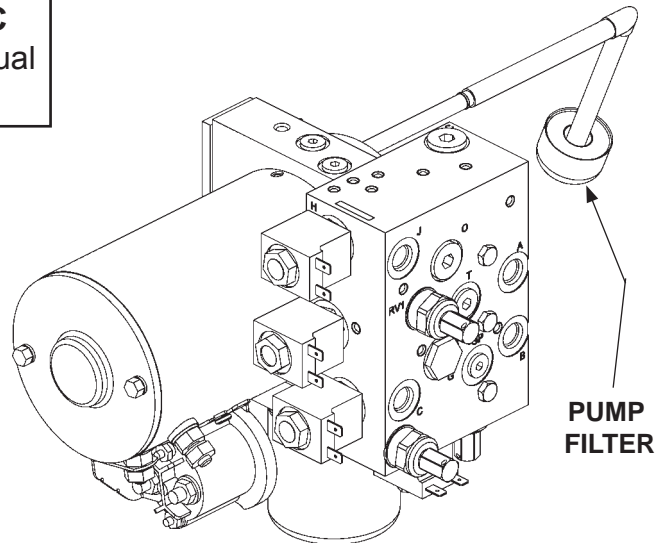

**SPIN-ON FILTER
FIG. 88-1**

7. If pump runs hot and extremely noisy, replace it.

NOTE: Do the **BLEEDING HYDRAULIC SYSTEM** procedure in this manual with the following step.

8. At the top of each column, loosen nut and disconnect hydraulic line from connector on bottom of flow control valve (**FIG. 88-2**). Check if the flow control valves are contaminated. Try to move plunger with small screwdriver through bottom of connector (**FIG. 88-2**). Replace valve if contaminated or not working.

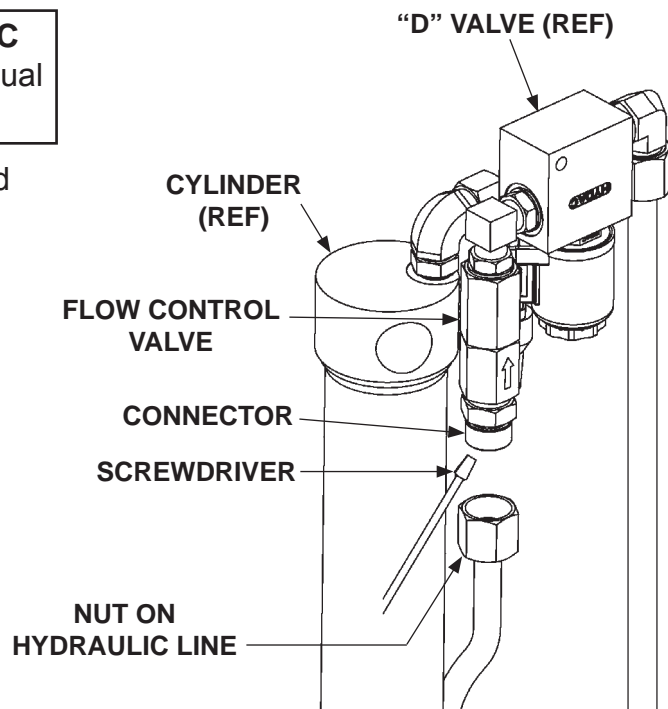

FIG. 88-2

TROUBLESHOOTING

PLATFORM WILL NOT FOLD (MTE PUMP)

1. Check the hydraulic fluid level in the reservoir. Refer to the **CHECKING HYDRAULIC FLUID** procedure in this manual.
 - **GRAVITY DOWN LIFTGATES:** Lower the platform to the ground. Clean dirt and fluid from top of reservoir in pump box. Fill the reservoir to correct level indicated on sight glass (pump box).
 - **POWER DOWN LIFTGATES:** Raise the platform to bed height. Fill the reservoir to correct level indicated on sight glass (pump box).

NOTE: For dual pump system, check secondary pump and motor first.

2. Check pump motor solenoid (**FIG. 89-1**) in pump box and bus bar connections in pump box. Make sure bus bar connections are clean and tight. Use a 6" long, 10 gauge insulated wire as a jumper between motor solenoid terminals "C" and "A" to activate solenoid. Replace solenoid if it fails to activate.

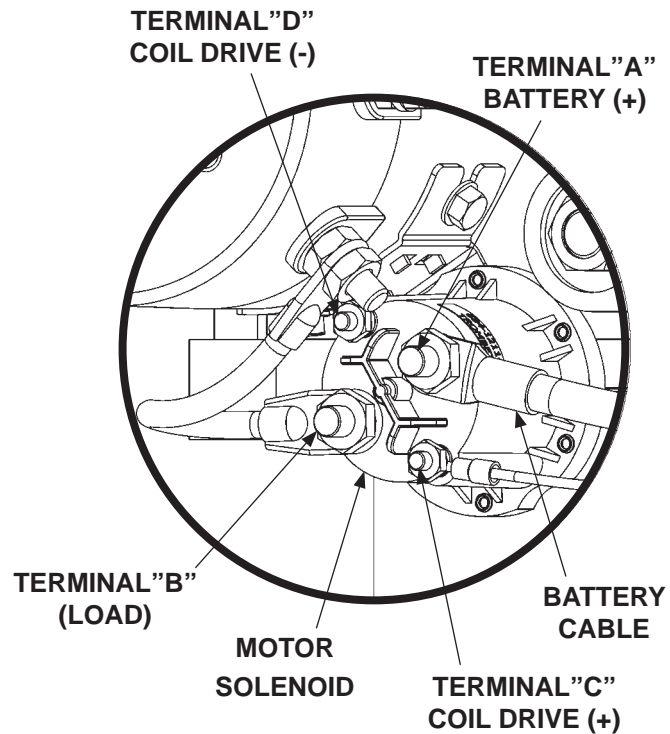

**TYPICAL MOTOR SOLENOID ELECTRICAL CONNECTIONS
(POWER DOWN PUMP IS SHOWN)**

FIG. 89-1

3. Verify that relief valve pressure settings are correct. Refer to **RELIEF VALVE PRESSURE SETTING** procedure in this manual. Also, make sure flow control valve (on pump) is open. Perform platform opening & closing speed adjustment procedure. If pressure settings can't be corrected, if platform opening and closing speed can't be adjusted or if pump runs hot and excessively noisy, replace pump.

⚠ WARNING

Make sure Liftgate platform is open and resting on the ground before performing the following step.

CAUTION

To prevent damage when installing valve cartridges & coils, torque valve cartridge nut to 15-45 lbs.-in.

4. The “E” solenoid valve (**FIG. 90-1**) may be stuck in the “open” position. Remove the “E” solenoid valve (**FIG. 90-2**). Next, check the valve cartridge as follows. Push on the plunger in the valve by inserting small screwdriver in the open end (**FIG. 90-3**). If the plunger does not move with a smooth, spring-loaded action (approximately 1/8”) (**FIG. 90-3**), replace the valve cartridge.

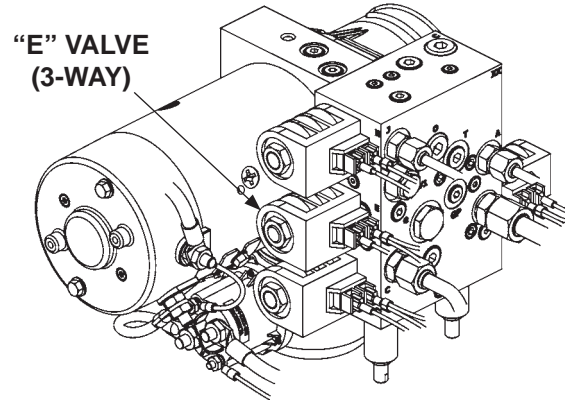

**TYPICAL SOLENOID VALVES
(POWER DOWN PUMP IS SHOWN)
FIG. 90-1**

5. Reinstall “E” solenoid valve (**FIG. 90-1**) (if good) or a replacement. **Torque valve cartridge to 25-30 lb-ft and coil nut to 15-45 lb-in.**

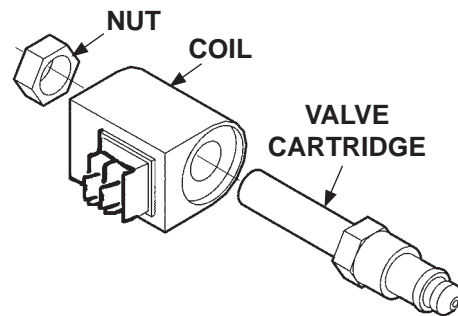

**TYPICAL SOLENOID VALVE
REMOVED & DISASSEMBLED
FIG. 90-2**

6. Check for bent parts on the Liftgate that could interfere with normal operation.

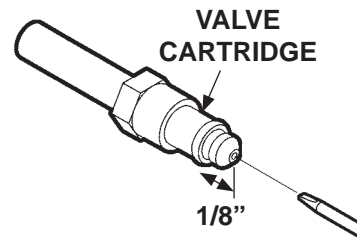

**CHECKING VALVE CARTRIDGE
FIG. 90-3**

7. Check if hydraulic fluid is streaming from breather plug.

TROUBLESHOOTING

PLATFORM WILL NOT FOLD (BUCHER PUMP)

1. Check the hydraulic fluid level in the reservoir. Refer to the **CHECKING HYDRAULIC FLUID** procedure in this manual.

- **GRAVITY DOWN LIFTGATES:** Lower the platform to the ground. Clean dirt and fluid from top of reservoir in pump box. Fill the reservoir to correct level indicated on sight glass (pump box).
- **POWER DOWN LIFTGATES:** Raise the platform to bed height. Fill the reservoir to correct level indicated on sight glass (pump box).

NOTE: For dual pump system, check secondary pump and motor first.

2. Check pump motor solenoid (**FIG. 91-1**) in pump box and bus bar connections in pump box. Make sure bus bar connections are clean and tight. Use a 6" long, 10 gauge insulated wire as a jumper between motor solenoid terminals "C" and "A" to activate solenoid. Replace solenoid if it fails to activate.

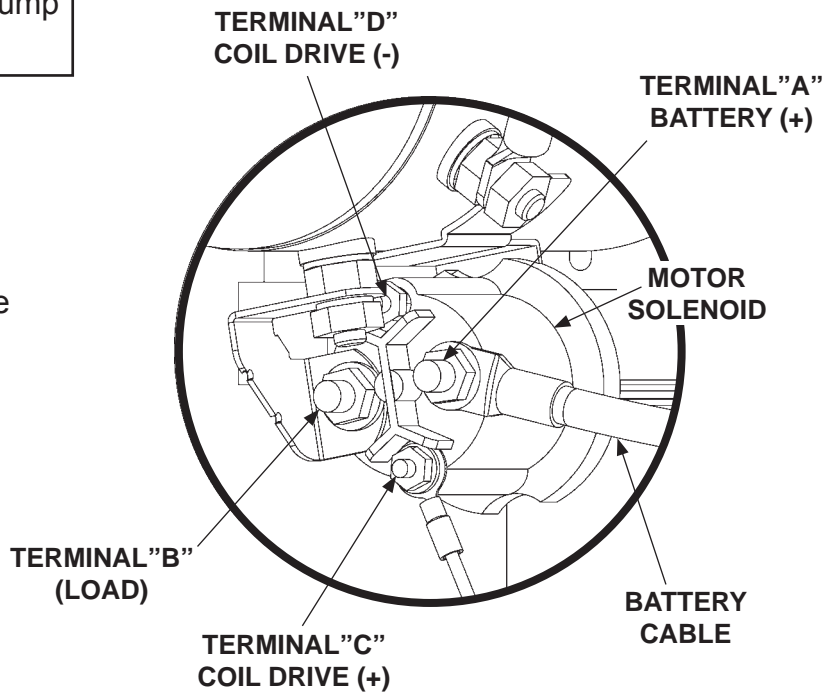

**TYPICAL MOTOR SOLENOID ELECTRICAL CONNECTIONS
(POWER DOWN PUMP IS SHOWN)**

FIG. 91-1

3. Verify that relief valve pressure settings are correct. Refer to **RELIEF VALVE PRESSURE SETTING** procedure in this manual. Also, make sure flow control valve (on pump) is open. Perform platform opening & closing speed adjustment procedure. If pressure settings can't be corrected, if platform opening and closing speed can't be adjusted or if pump runs hot and excessively noisy, replace pump.

⚠ WARNING

Make sure Liftgate platform is open and resting on the ground before performing the following step.

CAUTION

To prevent damage when installing valve cartridges & coils, torque valve cartridge to 25-30 lb-ft and coil nut to 15-45 lb-in.

4. The “E” solenoid valve (**FIG. 92-1**) may be stuck in the “open” position. Remove the “E” solenoid valve (**FIG. 92-2**). Next, check the valve cartridge as follows. Push on the plunger in the valve by inserting small screwdriver in the open end (**FIG. 92-3**). If the plunger does not move with a smooth, spring-loaded action (approximately 1/8”) (**FIG. 92-3**), replace the valve cartridge.

5. Reinstall “E” solenoid valve (if good) or a replacement. **Torque valve cartridge to 25-30 lb-ft and coil nut to 15-45 lb-in.**

6. Check for bent parts on the Liftgate that could interfere with normal operation.

7. Check if hydraulic fluid is streaming from breather plug.

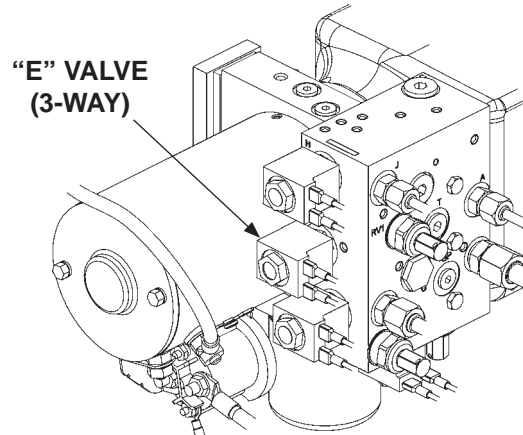

TYPICAL SOLENOID VALVES
(POWER DOWN PUMP IS SHOWN)

FIG. 92-1

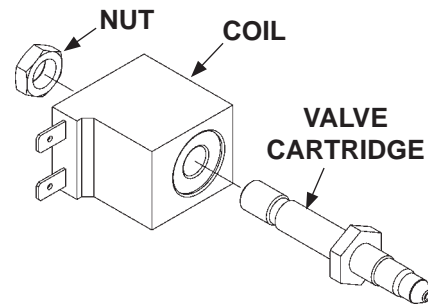

TYPICAL SOLENOID VALVE
REMOVED & DISASSEMBLED

FIG. 92-2

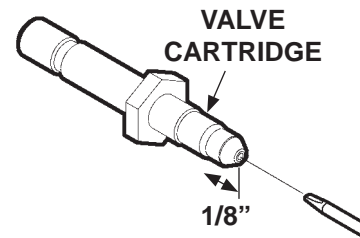

CHECKING VALVE CARTRIDGE

FIG. 92-3

TROUBLESHOOTING

PLATFORM WILL NOT UNFOLD (MTE PUMP)

⚠ WARNING

Before doing the following procedure, set up guarded area around the platform to keep people from entering.

NOTE: For dual pump system, check secondary pump and motor first.

NOTE: Numbers for the electrical terminals are not stamped on the valve coil. Numbers shown in illustration are for reference only.

1. Check if the “H” valve (**FIG. 93-1**) is energized. Refer to **HYDRAULIC SYSTEM DIAGRAMS** in this manual.
2. Connect voltmeter to Terminal-1 and Terminal-2 as shown in **FIG. 93-1** and **93-1A**. Set control switches to **FOLD/UNFOLD** and **UNFOLD**. Correct indication is +11 to +12.6 volts DC. If indication is incorrect, check control switch and wiring to “H” valve. Refer to **ELECTRICAL SYSTEM DIAGRAMS** in this manual. Replace faulty wiring or control switch as required. If the voltmeter indicates +11 to +12.6 volts DC and “H” valve does not operate, replace “H” valve (**FIG. 93-1**).

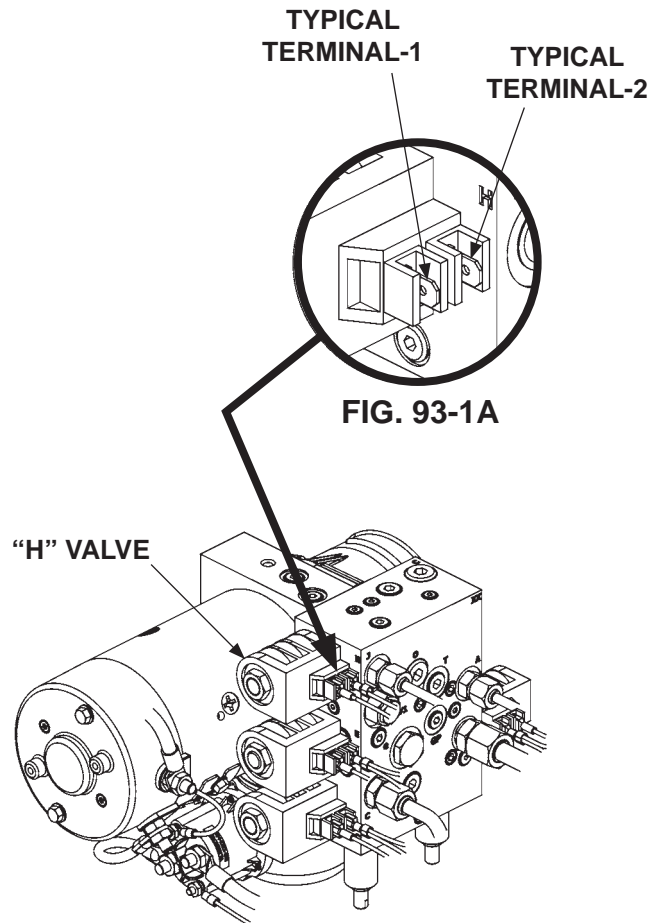

**TYPICAL VALVES & ELECTRICAL CONNECTIONS
(POWER DOWN PUMP IS SHOWN)
FIG. 93-1**

⚠ WARNING

Make sure Liftgate platform is open and resting on the ground before performing the following step.

CAUTION

To prevent damage when installing valve cartridges & coils, torque valve cartridge to 25-30 lb-ft and coil nut to 15-45 lb-in.

3. The “E” solenoid valve (**FIG. 94-1**) may be stuck in the “open” position. Remove the “E” solenoid valve (**FIG. 94-2**). Next, check the valve cartridge as follows. Push on the plunger in the valve by inserting a small screwdriver in the open end (**FIG. 94-3**). If the plunger does not move with a smooth, spring-loaded action (approximately 1/8”) (**FIG. 94-3**), replace the valve cartridge.
4. Reinstall “E” solenoid valve (if good) or a replacement. **Torque valve cartridge to 25-30 lb-ft and coil nut to 15-45 lb-in.**
5. Verify that relief valve pressure settings are correct. Refer to **POWER OPEN/CLOSE RELIEF VALVE PRESSURE SETTING** procedure in this manual. Also, make sure opening flow control valve (in pump) is open. If correct pressure settings cannot be made or if pump runs hot with excessive noise, replace pump.
6. Check for damage and corrosion at platform pivot points. Steam clean corrosion from pivot points. Replace bushings at pivot points if required.
7. Check for bent and broken parts on the Liftgate that could interfere with normal operation. Look at columns, runners, tandem rollers and platform (bent pins).

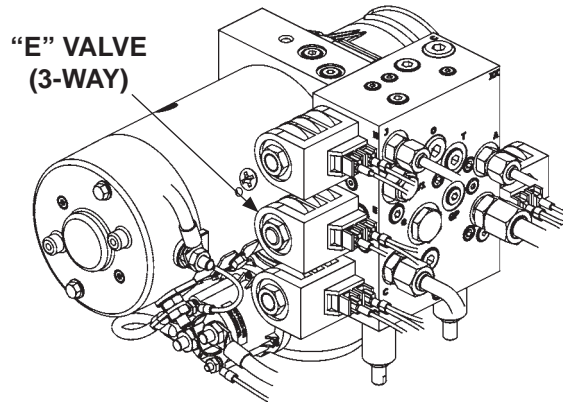

**TYPICAL SOLENOID VALVES
(POWER DOWN PUMP IS SHOWN)
FIG. 94-1**

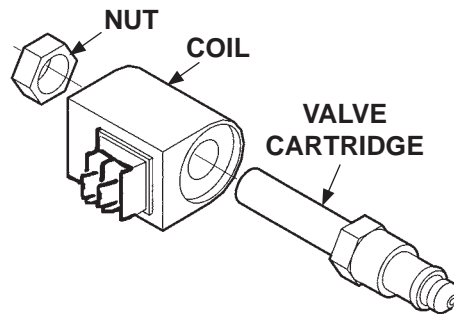

**TYPICAL SOLENOID VALVE
REMOVED & DISASSEMBLED
FIG. 94-2**

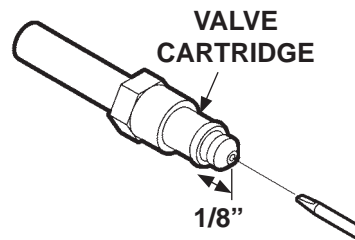

**CHECKING VALVE CARTRIDGE
FIG. 94-3**

TROUBLESHOOTING PLATFORM WILL NOT UNFOLD (BUCHER PUMP)

⚠ WARNING

Before doing the following procedure, set up guarded area around the platform to keep people from entering.

NOTE: For dual pump system, check secondary pump and motor first.

NOTE: Numbers for the electrical terminals are not stamped on the valve coil. Numbers shown in illustration are for reference only.

1. Check if the “H” valve (**FIG. 95-1**) is energized. Refer to **HYDRAULIC SYSTEM DIAGRAMS** in this manual.
2. Connect voltmeter to Terminal-1 and Terminal-2 as shown in **FIG. 95-1 and 95-1A**. Set control switches to **FOLD/UNFOLD** and **UNFOLD**. Correct indication is +11 to +12.6 volts DC. If indication is incorrect, check control switch and wiring to “H” valve. Refer to **ELECTRICAL SYSTEM DIAGRAMS** in this manual. Replace faulty wiring or control switch as required. If the voltmeter indicates +11 to +12.6 volts DC and “H” valve does not operate, replace “H” valve (**FIG. 95-1**).

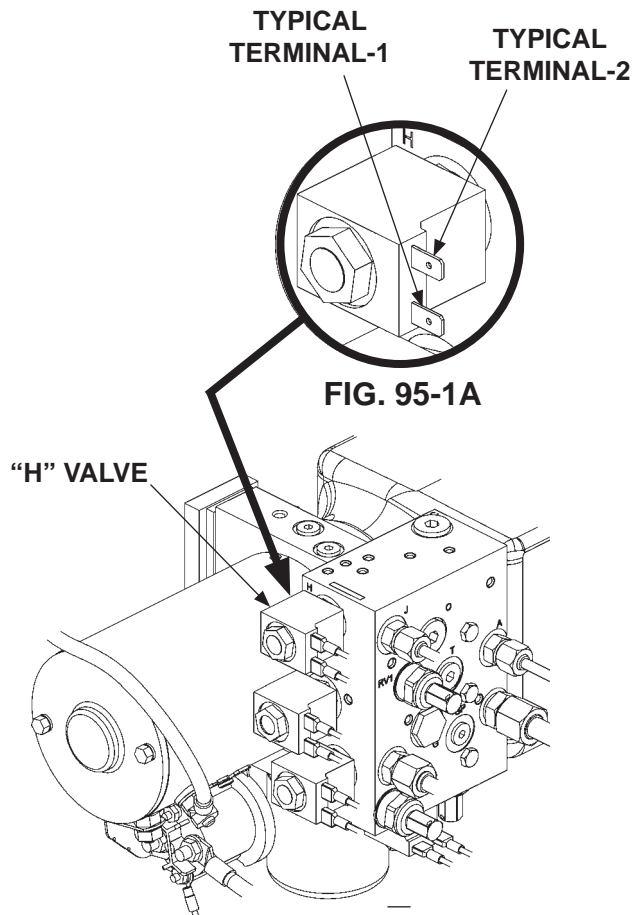

**TYPICAL VALVES & ELECTRICAL CONNECTIONS
(POWER DOWN PUMP IS SHOWN)**

FIG. 95-1

⚠ WARNING

Make sure Liftgate platform is open and resting on the ground before performing the following step.

CAUTION

To prevent damage when installing valve cartridges & coils, torque valve cartridge to 25-30 lb-ft and coil nut to 15-45 lb-in.

3. The “E” solenoid valve (FIG. 96-1) may be stuck in the “open” position. Remove the “E” solenoid valve (FIG. 96-2). Next, check the valve cartridge as follows. Push on the plunger in the valve by inserting a small screwdriver in the open end (FIG. 96-3). If the plunger does not move with a smooth, spring-loaded action (approximately 1/8”) (FIG. 96-3), replace the valve cartridge.
4. Reinstall “E” solenoid valve (if good) or a replacement. **Torque valve cartridge to 25-30 lb-ft and coil nut to 15-45 lb-in.**
5. Verify that relief valve pressure settings are correct. Refer to **POWER OPEN/CLOSE RELIEF VALVE PRESSURE SETTING** procedure in this manual. Also, make sure opening flow control valve (in pump) is open. If correct pressure settings cannot be made or if pump runs hot with excessive noise, replace pump.
6. Check for damage and corrosion at platform pivot points. Steam clean corrosion from pivot points. Replace bushings at pivot points if required.
7. Check for bent and broken parts on the Liftgate that could interfere with normal operation. Look at columns, runners, tandem rollers and platform (bent pins).

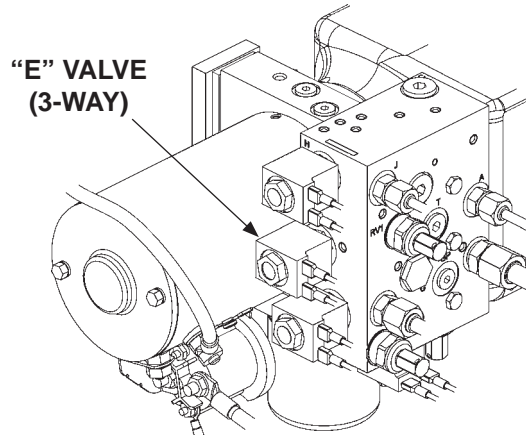

**TYPICAL SOLENOID VALVES
(POWER DOWN PUMP IS SHOWN)
FIG. 96-1**

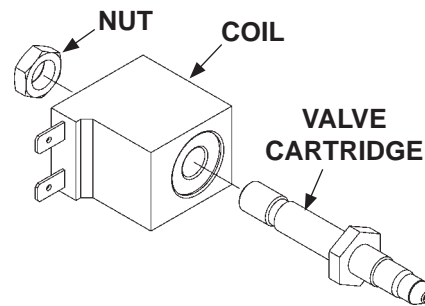

**TYPICAL SOLENOID VALVE
REMOVED & DISASSEMBLED
FIG. 96-2**

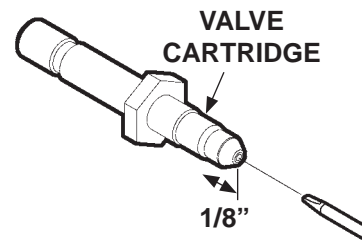

**CHECKING VALVE CARTRIDGE
FIG. 96-3**

TROUBLESHOOTING

POWER OPEN/CLOSE RELIEF VALVE PRESSURE SETTING (MTE PUMP)

NOTE: The relief valve pressure is set at the factory; however, if a pressure check shows incorrect reading, use the following procedure to set the pressure to the correct reading.

1. Open the platform.
2. Remove plug from pump gauge port **GP** (FIG. 97-1).
3. Attach a 0-3000 PSI pressure gauge with high pressure hose, thread adapter fitting, and swivel fitting (if needed) to pump gauge port **GP** (FIG. 97-2).
4. Set control switch to **FOLD** (power close).
5. Remove the plug from **RV1** (FIG. 97-2). Turn the pressure adjuster **RV1** for a **2100 PSI** reading on the gauge. Then slowly adjust valve for a **2400 PSI** (factory setting) reading on the gauge.
6. After adjustments are complete, remove gauge, hose, and fittings. Then, reinstall plug in gauge port **GP** (FIG. 97-1).

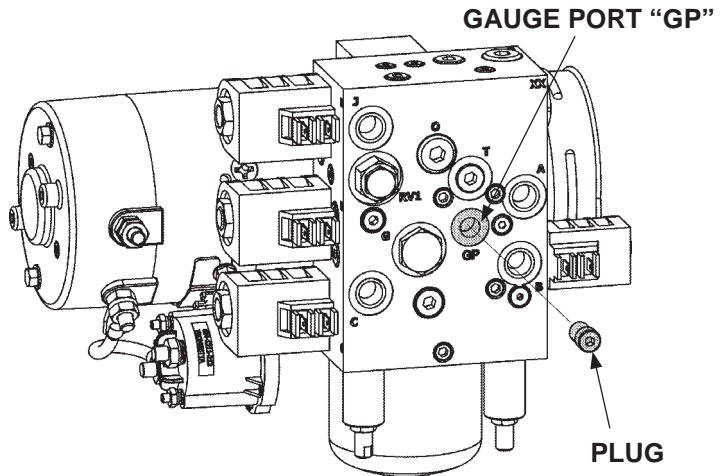

GAUGE PORT "GP"
FIG. 97-1

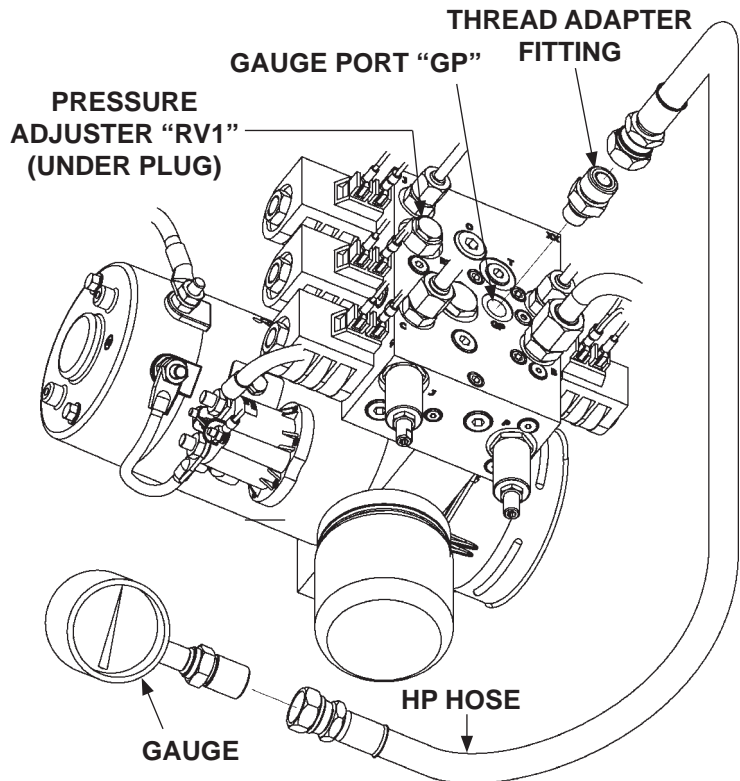

**GAUGE CONNECTION AND PRESSURE
ADJUSTER ON PORT PLATE
(POWER DOWN PUMP IS SHOWN)**
FIG. 97-2

TROUBLESHOOTING

POWER OPEN/CLOSE RELIEF VALVE PRESSURE SETTING (BUCHER PUMP)

NOTE: The relief valve pressure is set at the factory; however, if a pressure check shows incorrect reading, use the following procedure to set the pressure to the correct reading.

1. Open the platform.
2. Remove plug from pump gauge port **GP** (FIG. 98-1).
3. Attach a 0-3000 PSI pressure gauge with high pressure hose, thread adapter fitting, and swivel fitting (if needed) to pump gauge port **GP** (FIG. 98-2).
4. Set control switch to **FOLD** (power close).
5. Remove the plug from **RV1** (FIG. 98-2). Turn the pressure adjuster **RV1** for a **2100 PSI** reading on the gauge. Then slowly adjust valve for a **2400 PSI** (factory setting) reading on the gauge.
6. After adjustments are complete, remove gauge, hose, and fittings. Then, reinstall plug in gauge port **GP** (FIG. 98-1).

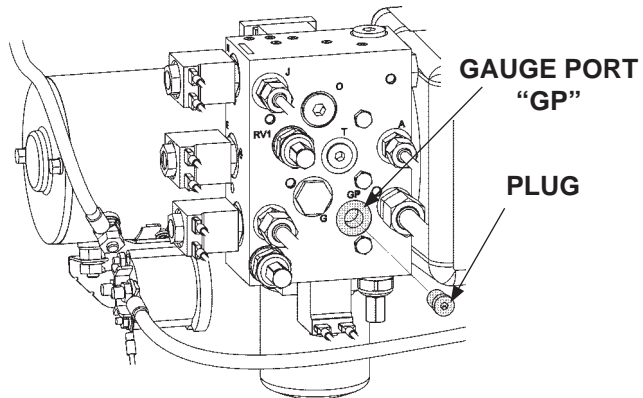

GAUGE PORT "GP"
FIG. 98-1

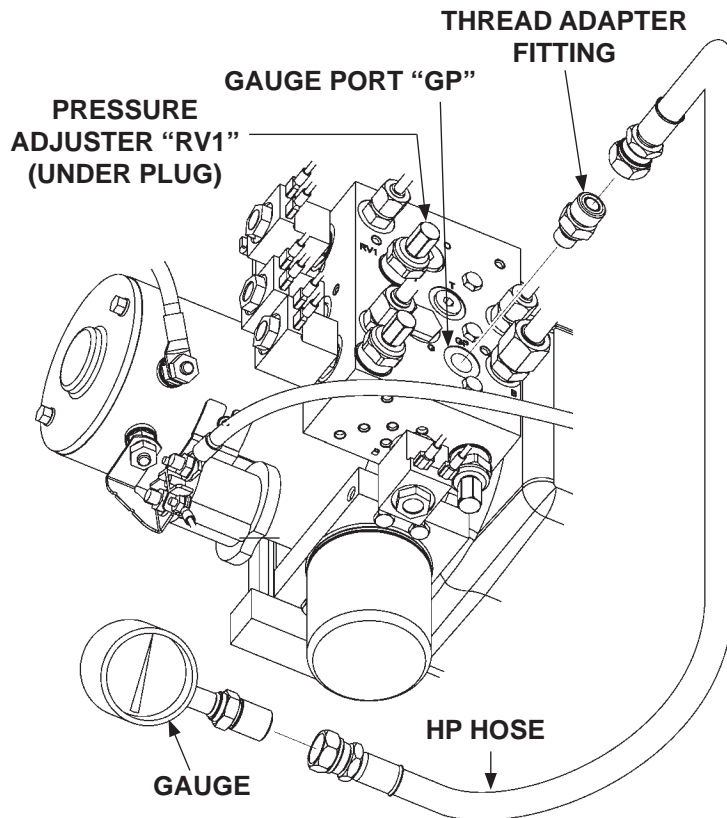

**GAUGE CONNECTION AND PRESSURE
ADJUSTER ON PORT PLATE
(POWER DOWN PUMP IS SHOWN)**
FIG. 98-2

TROUBLESHOOTING

LIFTING LINE RELIEF VALVE PRESSURE SETTING (MTE PUMP)

NOTE: The relief valve pressure is set at the factory; however, if a pressure check shows incorrect reading, use the following procedure to set the pressure to the correct reading.

1. Stow the platform.
2. Remove plug from pump gauge port **GP** (FIG. 99-1).
3. Attach a 0-3000 PSI pressure gauge with high pressure hose, thread adapter fitting, and swivel fitting (if needed) to pump gauge port **GP** (FIG. 99-2).
4. Set control switch to **UP** position to run pump motor.
5. Turn the pressure adjuster **P** (FIG. 99-1) for a **2100 PSI** reading on the gauge (FIG. 99-2). Then, slowly adjust valve for a **2400 PSI** reading.
6. After adjustments are complete, remove gauge and any temporary hoses, adapters and plugs. Reinstall plug securely in gauge port **GP** (FIG. 99-1).

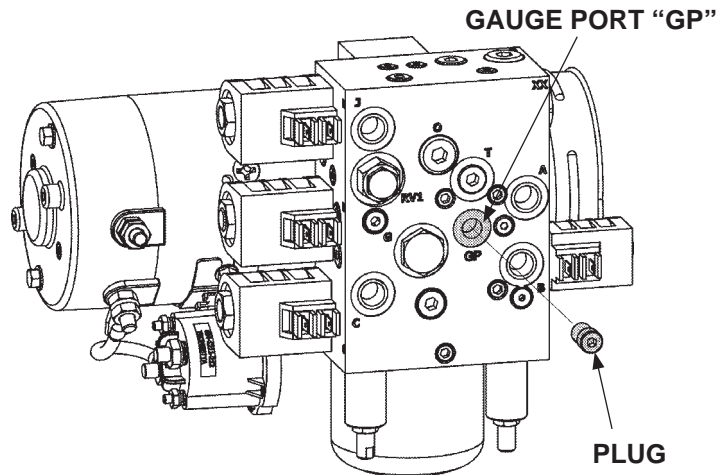

GAUGE PORT "GP"
FIG. 99-1

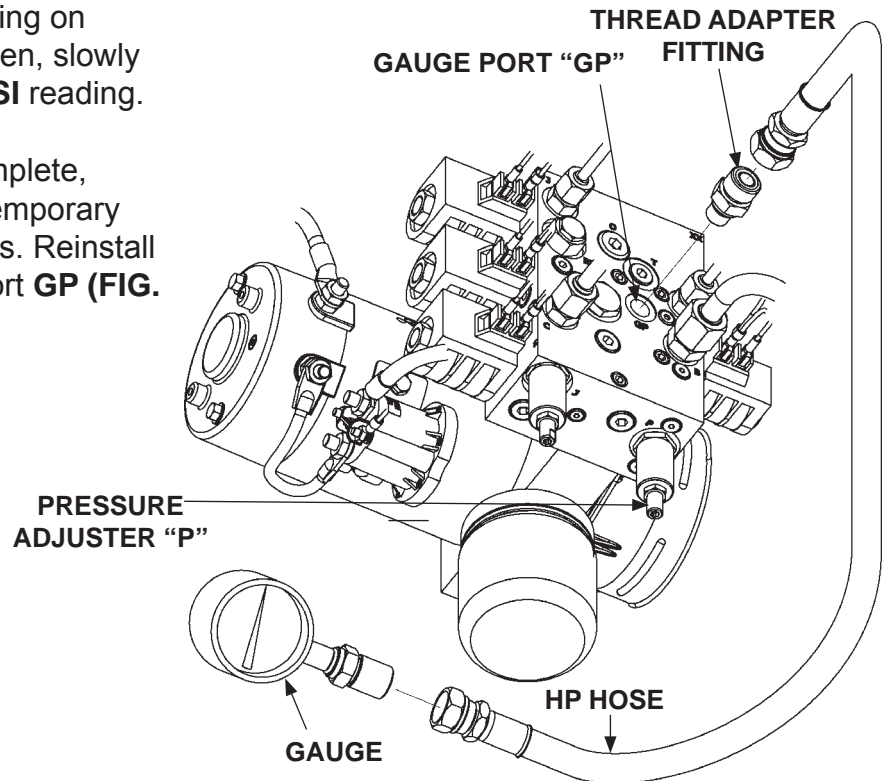

**GAUGE CONNECTION AND PRESSURE
ADJUSTER ON PORT PLATE
(POWER DOWN PUMP IS SHOWN)**
FIG. 99-2

TROUBLESHOOTING

LIFTING LINE RELIEF VALVE PRESSURE SETTING (BUCHER PUMP)

NOTE: The relief valve pressure is set at the factory; however, if a pressure check shows incorrect reading, use the following procedure to set the pressure to the correct reading.

1. Stow the platform.
2. Remove plug from pump gauge port **GP** (FIG. 100-1). Plug port **GP** with a plug (FIG. 100-2).
3. Attach a 0-3000 PSI pressure gauge with high pressure hose, thread adapter fitting, and swivel fitting (if needed) to pump gauge port **GP** (FIG. 100-2).
4. Set control switch to **UP** position to run pump motor.
5. Turn the pressure adjuster **P** (FIG. 100-2) for a 2100 PSI reading on the gauge (FIG. 100-2). Then, slowly adjust valve for a 2400 PSI reading.
6. After adjustments are complete, remove gauge and any temporary hoses, adapters and plugs. Reinstall plug securely in gauge port **GP** (FIG. 100-1).

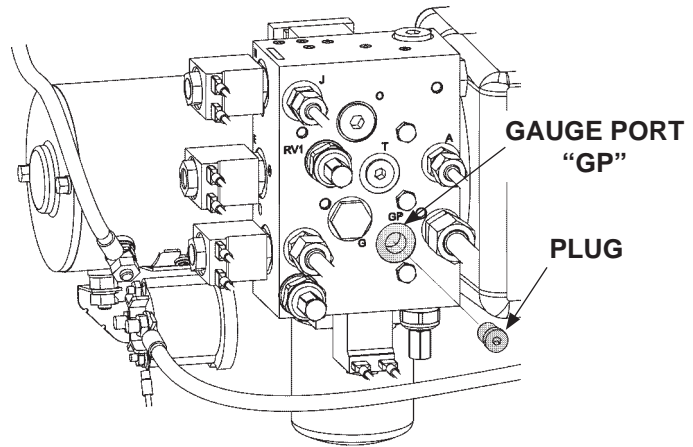

GAUGE PORT "GP"
FIG. 100-1

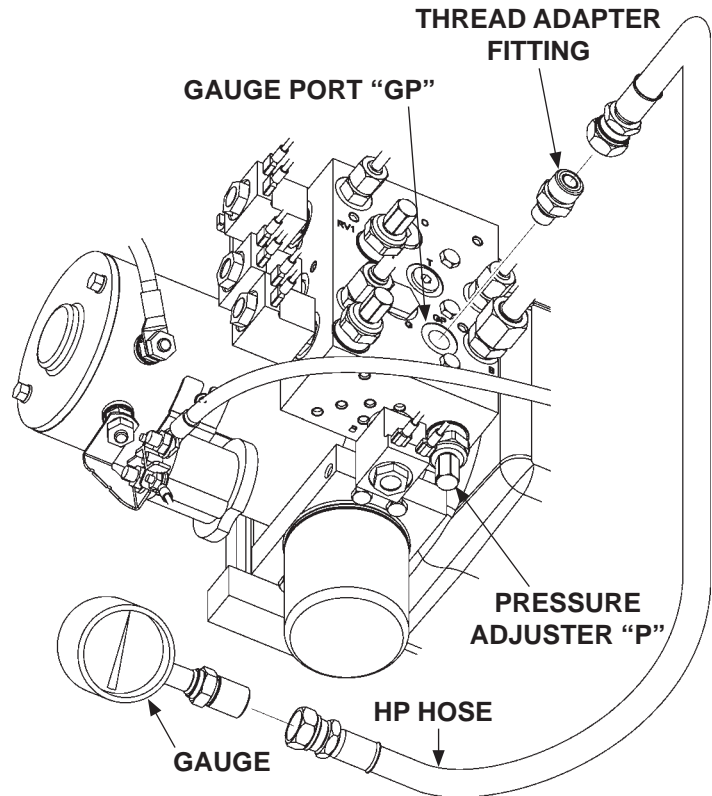

GAUGE CONNECTION AND PRESSURE ADJUSTER ON PORT PLATE (POWER DOWN PUMP IS SHOWN)
FIG. 100-2

TROUBLESHOOTING - GRAVITY DOWN PLATFORM WILL NOT LOWER (MTE PUMP)

NOTE: For dual pump system, check secondary pump and motor first.

NOTE: Numbers for the electrical terminals shown in the illustration are not stamped on valve coil. Numbers shown are for reference only.

1. Try lowering platform (activate **DOWN** toggle switch). Only the motor solenoid and "B" valve (**FIG. 101-1**) and "D" valve (on top of LH and RH columns) (**FIG. 101-1**) should be energized while lowering platform. Connect voltmeter to Terminal-1 and Terminal-2 on each valve shown in **FIG. 101-1A**. Correct indication for "B" and "D" valves is +11 to +12.6 volts DC. If indications are incorrect, check control switch and wiring to that valve (refer to **ELECTRICAL SYSTEM DIAGRAMS** section). Replace faulty wiring or control switch as required.

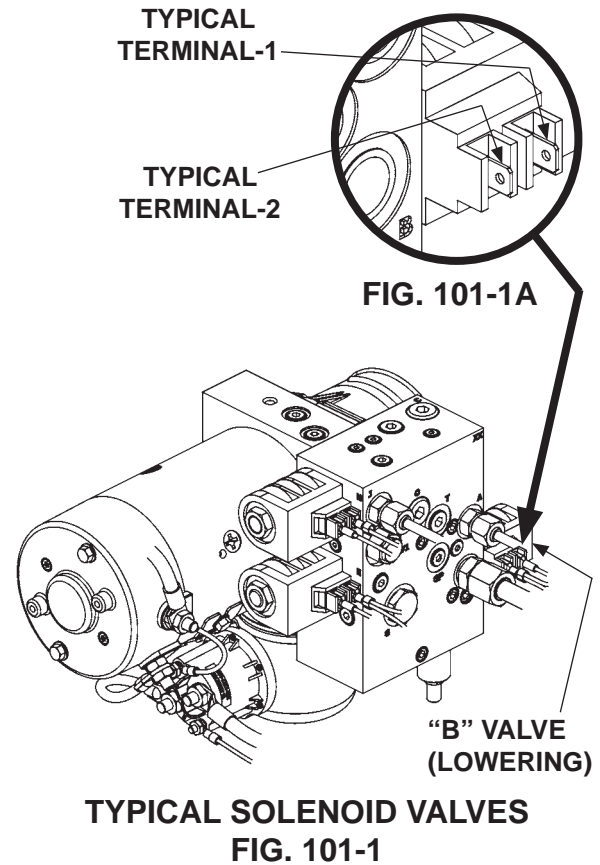

⚠ WARNING

Make sure Liftgate platform is open and resting on the ground before performing the following step.

CAUTION

To prevent damage when installing valve cartridges & coils, torque valve cartridge to 18.5-22 lb-in and coil nut to 3-4.5 lb-ft.

NOTE: Do the **BLEEDING HYDRAULIC SYSTEM** procedure in this manual with the following step.

2. Lower the platform to the ground. At the top of each column, loosen nut and disconnect hydraulic line from connector on bottom of flow control valve (**FIG. 102-1**). Check if the flow control valves are contaminated. Try to move plunger with small screwdriver through bottom of connector (**FIG. 102-1**). Replace valve if contaminated or not working.

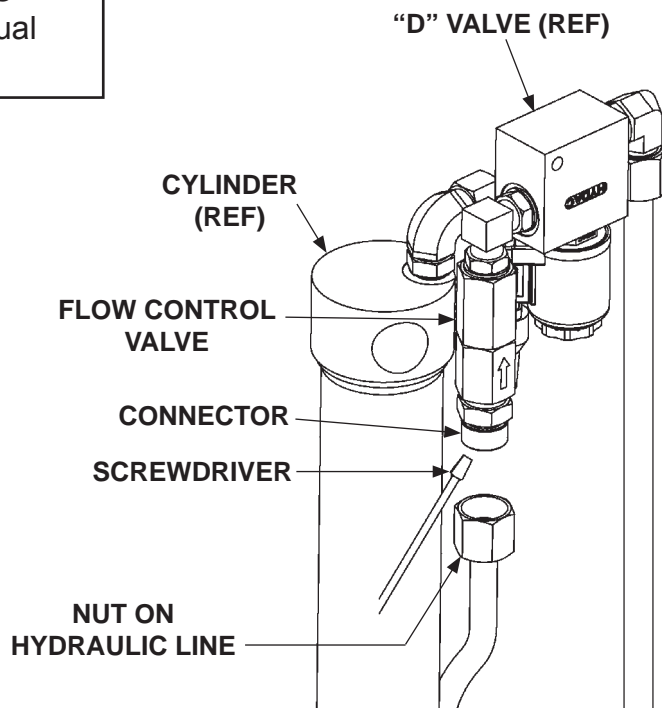
**FIG. 102-1**

TROUBLESHOOTING - GRAVITY DOWN PLATFORM WILL NOT LOWER (BUCHER PUMP)

NOTE: For dual pump system, check secondary pump and motor first.

NOTE: Numbers for the electrical terminals shown in the illustration are not stamped on valve coil. Numbers shown are for reference only.

1. Try lowering platform (activate **DOWN** toggle switch). Only the motor solenoid and "B" valve (**FIG. 103-1**) and "D" valve (on top of LH and RH columns) (**FIG. 103-1**) should be energized while lowering platform. Connect voltmeter to Terminal-1 and Terminal-2 on each valve shown in **FIG. 103-1A**. Correct indication for "B" and "D" valves is +11 to +12.6 volts DC. If indications are incorrect, check control switch and wiring to that valve (refer to **ELECTRICAL SYSTEM DIAGRAMS** section). Replace faulty wiring or control switch as required.

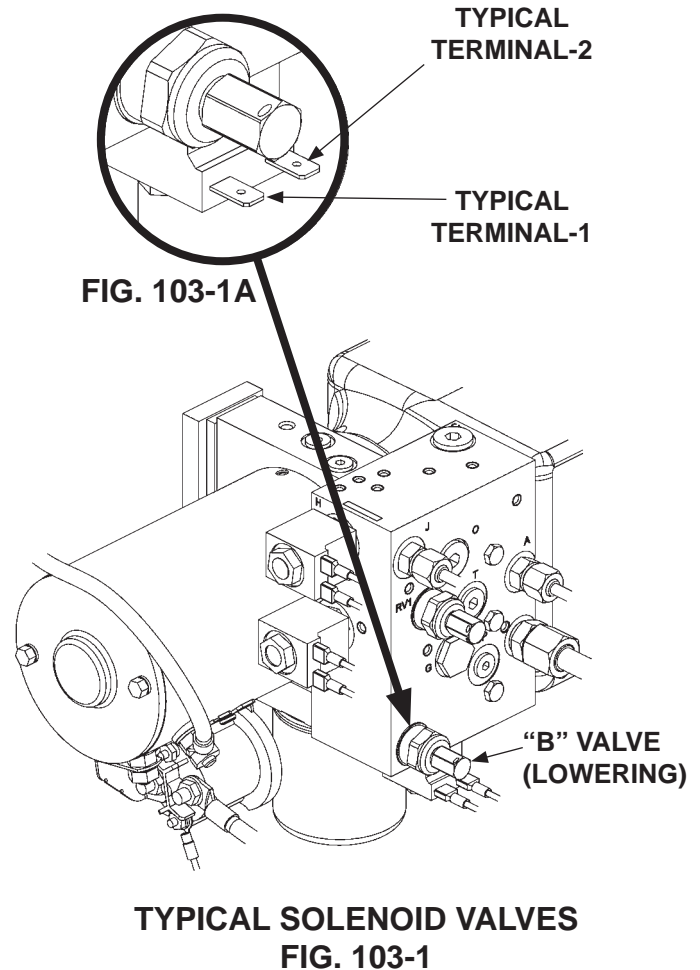

⚠ WARNING

Make sure Liftgate platform is open and resting on the ground before performing the following step.

CAUTION

To prevent damage when installing valve cartridges & coils, torque valve cartridge to 18.5-22 lb-in and coil nut to 3-4.5 lb-ft.

NOTE: Do the **BLEEDING HYDRAULIC SYSTEM** procedure in this manual with the following step.

2. Lower the platform to the ground. At the top of each column, loosen nut and disconnect hydraulic line from connector on bottom of flow control valve (**FIG. 104-1**). Check if the flow control valves are contaminated. Try to move plunger with small screwdriver through bottom of connector (**FIG. 104-1**). Replace valve if contaminated or not working.

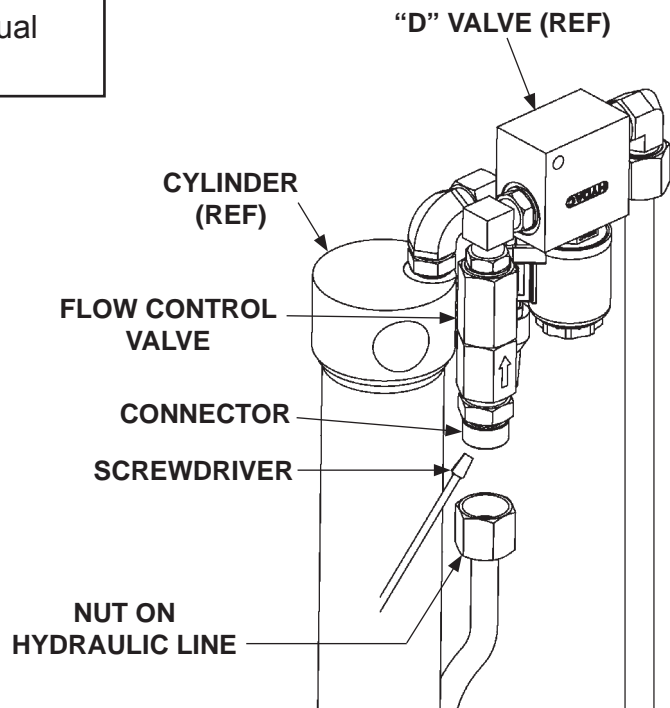
**FIG. 104-1**

TROUBLESHOOTING - GRAVITY DOWN PLATFORM LOWERS SLOWLY (MTE PUMP)

NOTE: For dual pump system, check secondary pump and motor first.

NOTE: Numbers for the electrical terminals shown in the illustration are not stamped on valve coil. Numbers shown are for reference only.

1. Check if the “B” solenoid valve coil (**FIGS. 105-1 and 105-1A**) is getting power. Connect voltmeter to Terminal-1 and Terminal-2 of the coil. Activate the **DOWN** toggle switch. Correct indication is +11 to +12.6 volts DC. If the voltmeter does not indicate +11 to +12.6 volts DC, check control switch and wiring to “B” solenoid valve (refer to **ELECTRICAL SYSTEM DIAGRAMS** section). Replace faulty wiring or control switch as required. If the voltmeter indicates +11 to +12.6 volts DC and valve still does not operate, replace the valve.

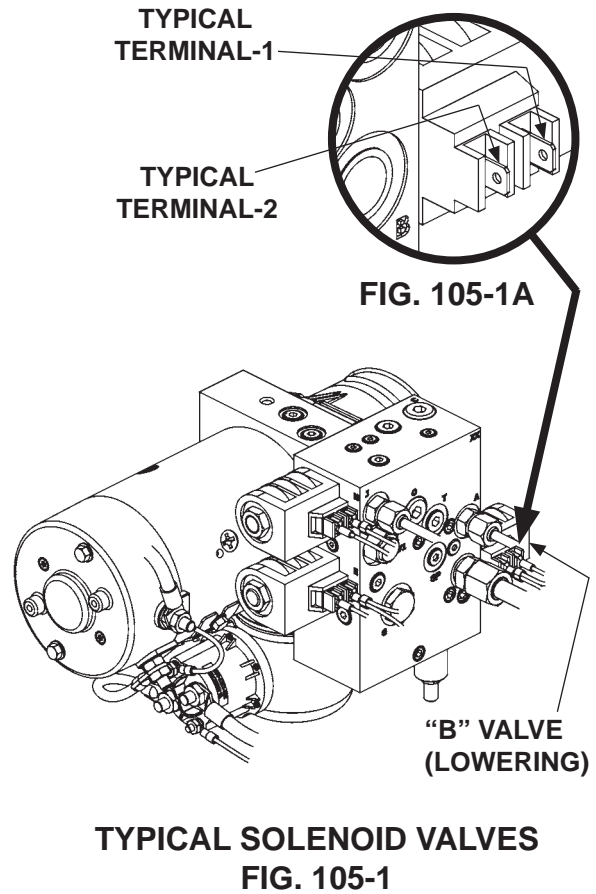

⚠ WARNING

Make sure Liftgate platform is open and resting on the ground before performing the following step.

CAUTION

To prevent damage when installing valve cartridges & coils, torque valve cartridge to 25-30 lb-ft and coil nut to 15-45 lb-in.

2. The “B” solenoid valve (**FIG. 106-1**) may be stuck in the “open” position. Remove the “B” solenoid valve (**FIG. 106-1**). Next, check the valve cartridge as follows. Push on the plunger in the valve by inserting small screwdriver in the open end (**FIG. 106-2**). If the plunger does not move with a smooth, spring-loaded action (approximately 1/8”), replace the valve cartridge.
3. Reinstall “B” solenoid valve (if good) (**FIG. 106-1**) or a replacement. **Torque valve cartridge to 25-30 lb-ft and coil nut to 15-45 lb-in.**
4. Check for bent and broken parts on the Liftgate that could interfere with normal operation.
5. Check both flow control valves. Refer to the flow control valve instructions in the procedure for **PLATFORM RAISES AND LOWERS UNEVENLY.**

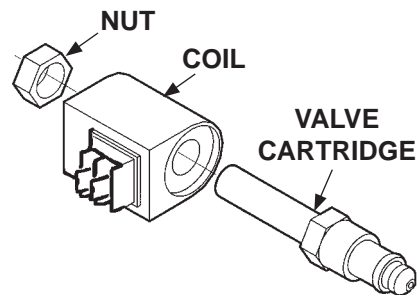

**TYPICAL SOLENOID VALVE
REMOVED & DISASSEMBLED
FIG. 106-1**

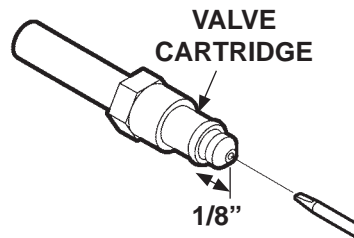

**CHECKING VALVE CARTRIDGE
FIG. 106-2**

TROUBLESHOOTING - GRAVITY DOWN PLATFORM LOWERS SLOWLY (BUCHER PUMP)

NOTE: For dual pump system, check secondary pump and motor first.

NOTE: Numbers for the electrical terminals shown in the illustration are not stamped on valve coil. Numbers shown are for reference only.

1. Check if the “B” solenoid valve coil (**FIGS. 107-1 and 107-1A**) is getting power. Connect voltmeter to Terminal-1 and Terminal-2 of the coil. Activate the **DOWN** toggle switch. Correct indication is +11 to +12.6 volts DC. If the voltmeter does not indicate +11 to +12.6 volts DC, check control switch and wiring to “B” solenoid valve (refer to **ELECTRICAL SYSTEM DIAGRAMS** section). Replace faulty wiring or control switch as required. If the voltmeter indicates +11 to +12.6 volts DC and valve still does not operate, replace the valve.

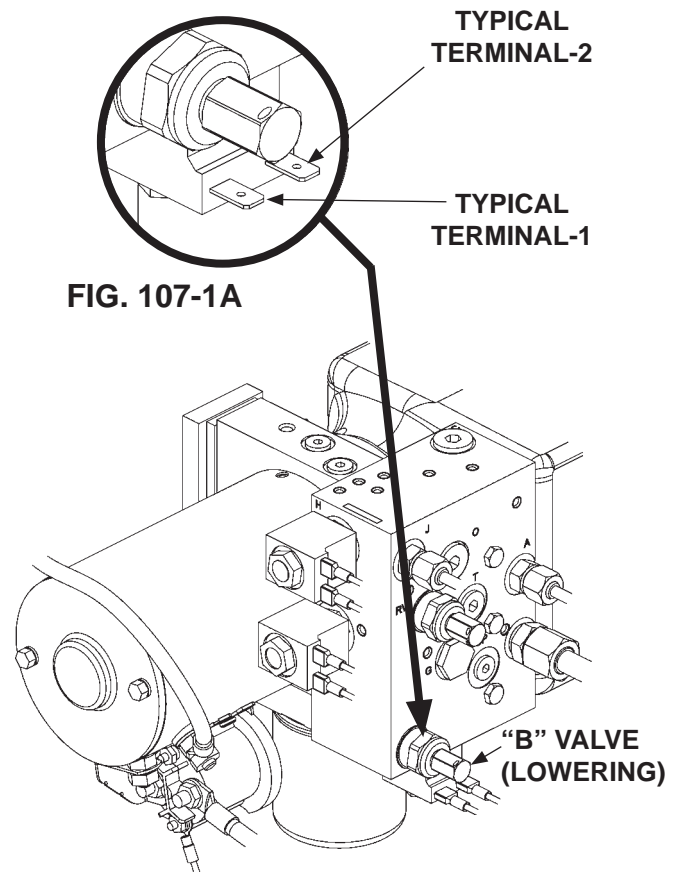

**TYPICAL SOLENOID VALVES
FIG. 107-1**

⚠ WARNING

Make sure Liftgate platform is open and resting on the ground before performing the following step.

CAUTION

To prevent damage when installing valve cartridges & coils, torque valve cartridge to 25-30 lb-ft and coil nut to 15-45 lb-in.

2. The “B” solenoid valve (**FIG. 108-1**) may be stuck in the “open” position. Remove the “B” solenoid valve (**FIG. 108-1**). Next, check the valve cartridge as follows. Push on the plunger in the valve by inserting small screwdriver in the open end (**FIG. 108-2**). If the plunger does not move with a smooth, spring-loaded action (approximately 1/8”), replace the valve cartridge.
3. Reinstall “B” solenoid valve (if good) (**FIG. 108-1**) or a replacement. **Torque valve cartridge to 25-30 lb-ft and coil nut to 15-45 lb-in.**
4. Check for bent and broken parts on the Liftgate that could interfere with normal operation.
5. Check both flow control valves. Refer to the flow control valve instructions in the procedure for **PLATFORM RAISES AND LOWERS UNEVENLY.**

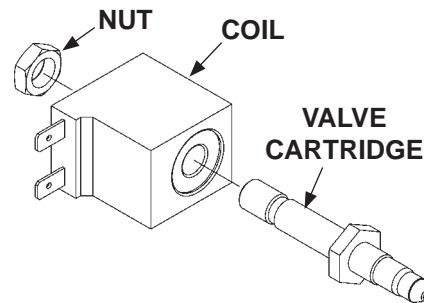

TYPICAL SOLENOID VALVE REMOVED & DISASSEMBLED FIG. 108-1

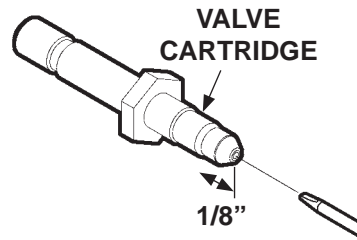

CHECKING VALVE CARTRIDGE FIG. 108-2

TROUBLESHOOTING - POWER DOWN RELIEF VALVE PRESSURE SETTING (MTE PUMP)

NOTE: The relief valve pressure is set at the factory; however, if a pressure check shows incorrect reading, use the following procedure to set the pressure to the correct reading.

NOTE: Ensure the power down shut off switch is set to **PD**.

1. Open the platform.
2. Remove plug from pump gauge port **GP** (FIG. 109-1).
3. Attach a 0-3000 PSI pressure gauge with high pressure hose, thread adapter fitting, and swivel fitting (if needed) to pump gauge port **GP** (FIG. 109-2).
4. Set control switch to **DOWN** (power close).
5. Turn the pressure adjuster **J** (FIG. 109-1) for a 400 PSI reading on the gauge (FIG. 109-2).
6. After adjustments are complete, remove gauge, hose, and fittings. Then, reinstall plug in gauge port **GP** (FIG. 109-1).

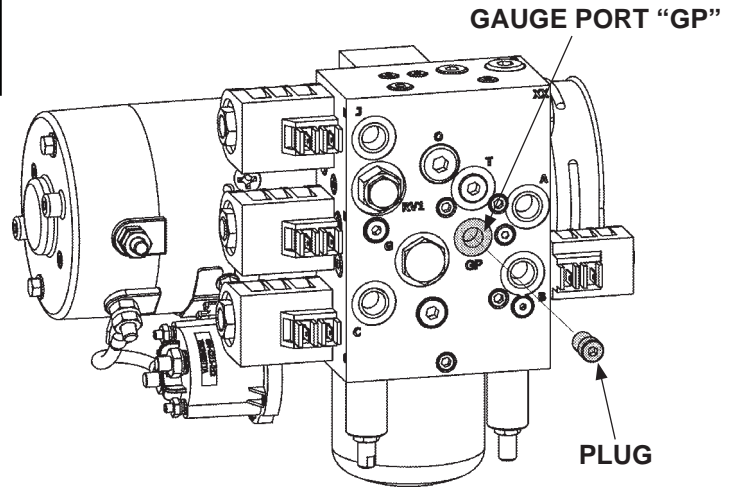

GAUGE PORT "GP"
FIG. 109-1

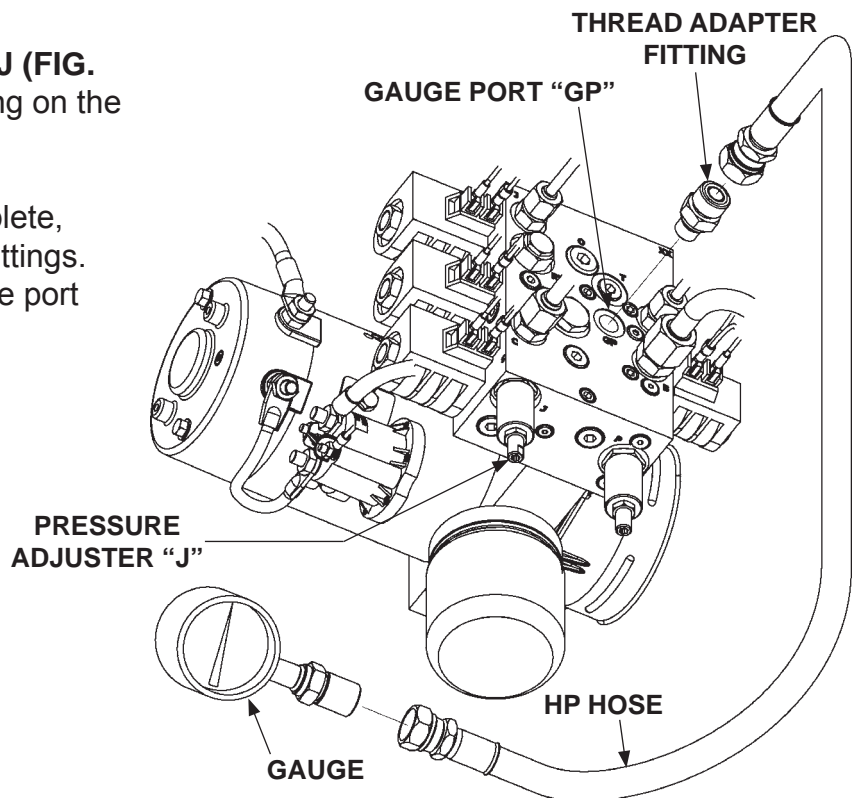

**GAUGE CONNECTION AND PRESSURE
ADJUSTER ON PORT PLATE**
FIG. 109-2

TROUBLESHOOTING - POWER DOWN RELIEF VALVE PRESSURE SETTING (BUCHER PUMP)

NOTE: The relief valve pressure is set at the factory; however, if a pressure check shows incorrect reading, use the following procedure to set the pressure to the correct reading.

NOTE: Ensure the power down shut off switch is set to **PD**.

1. Open the platform.
2. Remove plug from pump gauge port **GP** (FIG. 110-1).
3. Attach a 0-3000 PSI pressure gauge with high pressure hose, thread adapter fitting, and swivel fitting (if needed) to pump gauge port **GP** (FIG. 110-2).
4. Set control switch to **DOWN** (power close).
5. Turn the pressure adjuster **J** (FIG. 110-1) for a **400 PSI** reading on the gauge (FIG. 110-2).
6. After adjustments are complete, remove gauge, hose, and fittings. Then, reinstall plug in gauge port **GP** (FIG. 110-1).

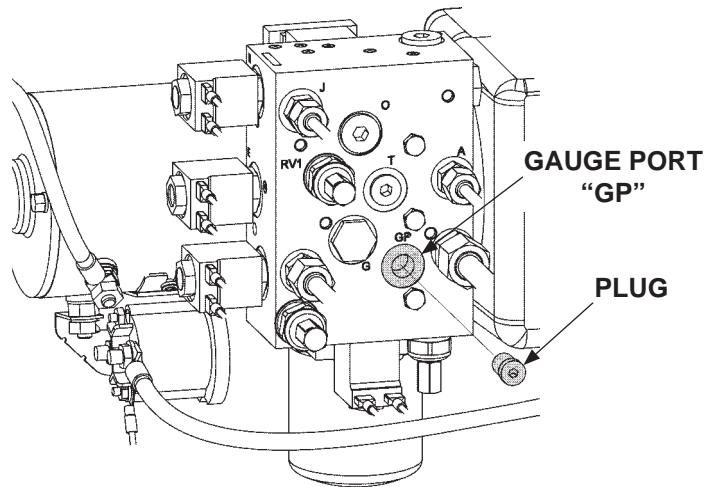

**GAUGE PORT "GP"
FIG. 110-1**

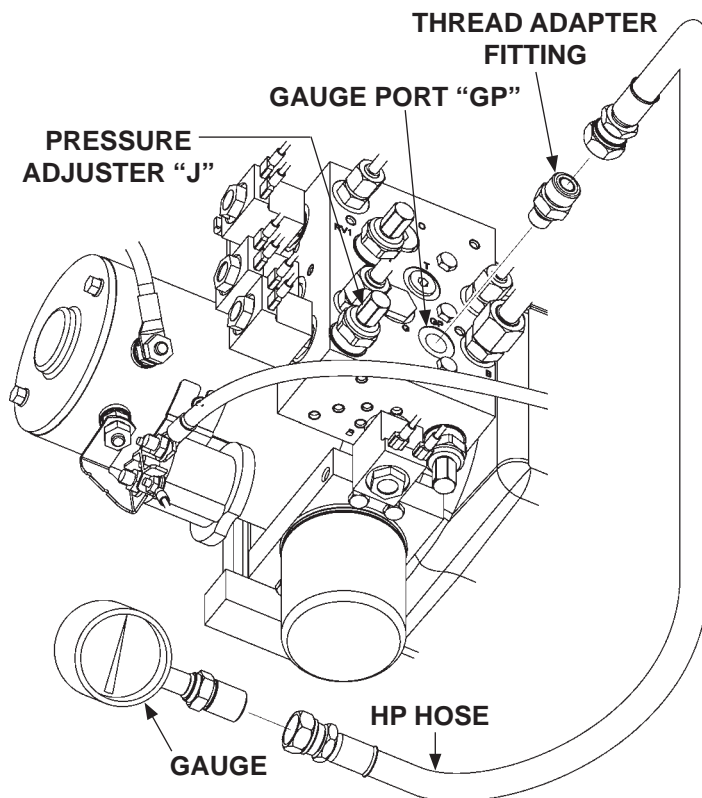

**GAUGE CONNECTION AND PRESSURE
ADJUSTER ON PORT PLATE
FIG. 110-2**

MAXON®

11921 Slauson Ave. Santa Fe Springs, CA. 90670 (800) 227-4116 FAX (888) 771-7713

TROUBLESHOOTING - POWER DOWN PLATFORM WILL NOT LOWER (MTE PUMP)

NOTE: For dual pump system, check secondary pump and motor first.

NOTE: Numbers for the electrical terminals shown in the illustration are not stamped on valve coil. Numbers shown are for reference only.

1. Try lowering platform (control switch **DOWN**). Only the starter solenoid, "B" valve, "C" valve (**FIG. 111-1**) and "D" valve (on top of LH and RH columns) (**FIG. 111-2**) should be energized while lowering platform. The "A" and "E" valves should not be energized. Refer to **HYDRAULIC SYSTEM DIAGRAMS** in this manual.

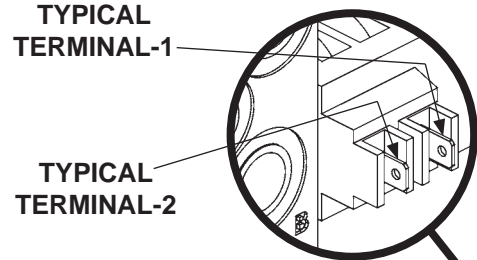
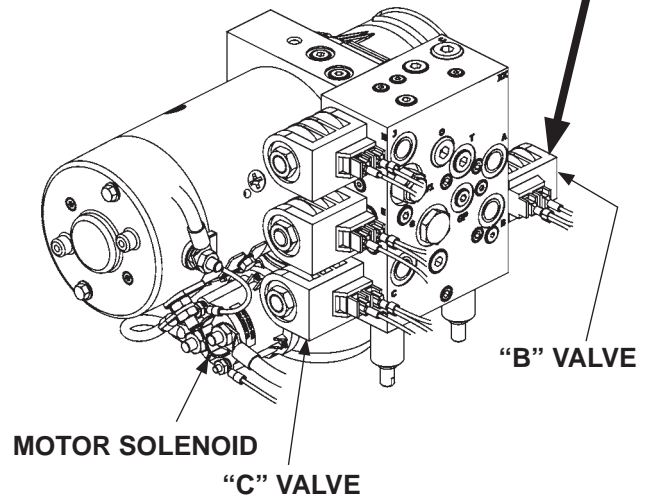
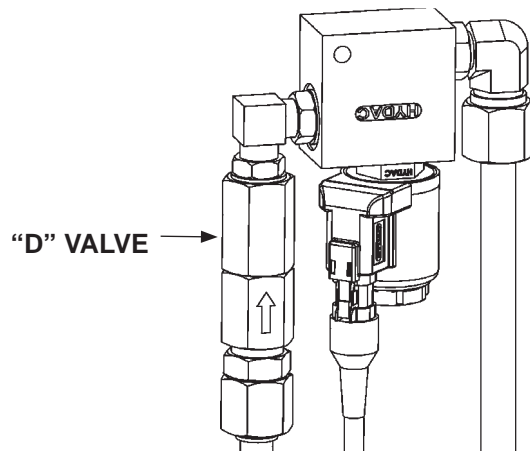

FIG. 111-1A



**STARTER SOLENOID, VALVES &
ELECTRICAL CONNECTIONS
FIG. 111-1**

2. Connect voltmeter to Terminal-1 and Terminal-2 on each valve shown in **FIG. 111-1A**. Correct indication for "A" and "E" valves is 0 volts DC. For "B", "C" and "D" valves, correct indication is +11 to +12.6 volts DC. If any indications are incorrect, check control switch and wiring to that valve. Refer to **ELECTRICAL SYSTEM DIAGRAMS** in this manual. Replace faulty wiring or control switch as required.



**"D" VALVE
FIG. 111-2**

⚠ WARNING

Make sure Liftgate platform is open and resting on the ground before performing the following step.

CAUTION

To prevent damage when installing valve cartridges & coils, torque valve cartridge to 18.5-22 lb-in and coil nut to 3-4.5 lb-ft.

NOTE: Do the **BLEEDING HYDRAULIC SYSTEM** procedure in this manual with the following step.

3. Lower the platform to the ground. At the top of each column, loosen nut and disconnect hydraulic line from connector on bottom of flow control valve (**FIG. 112-1**). Check if the flow control valves are contaminated. Try to move plunger with small screwdriver through bottom of connector (**FIG. 112-1**). Replace valve if contaminated or not working.

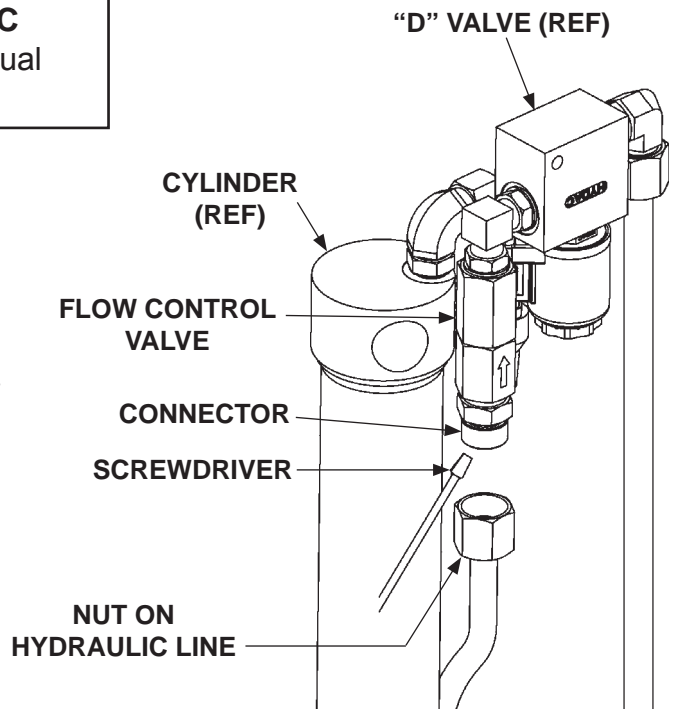

FIG. 112-1

TROUBLESHOOTING - POWER DOWN PLATFORM WILL NOT LOWER (BUCHER PUMP)

NOTE: For dual pump system, check secondary pump and motor first.

NOTE: Numbers for the electrical terminals shown in the illustration are not stamped on valve coil. Numbers shown are for reference only.

1. Try lowering platform (control switch **DOWN**). Only the starter solenoid, "B" valve, "C" valve (**FIG. 113-1**) and "D" valve (on top of LH and RH columns) (**FIG. 113-2**) should be energized while lowering platform. The "A" and "E" valves should not be energized. Refer to **HYDRAULIC SYSTEM DIAGRAMS** in this manual.

2. Connect voltmeter to Terminal-1 and Terminal-2 on each valve shown in **FIG. 113-1A**. Correct indication for "A" and "E" valves is 0 volts DC. For "B", "C" and "D" valves, correct indication is +11 to +12.6 volts DC. If any indications are incorrect, check control switch and wiring to that valve. Refer to **ELECTRICAL SYSTEM DIAGRAMS** in this manual. Replace faulty wiring or control switch as required.

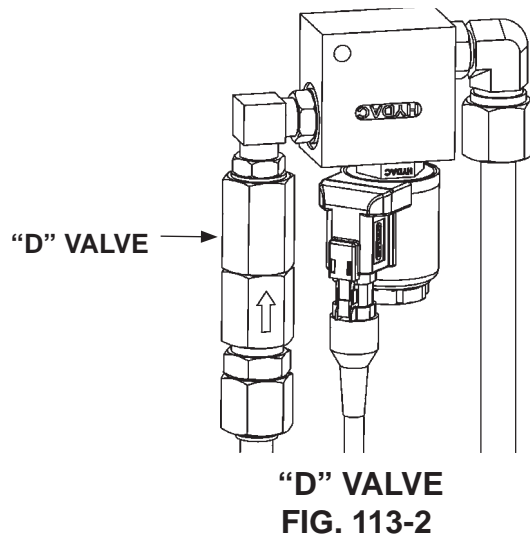
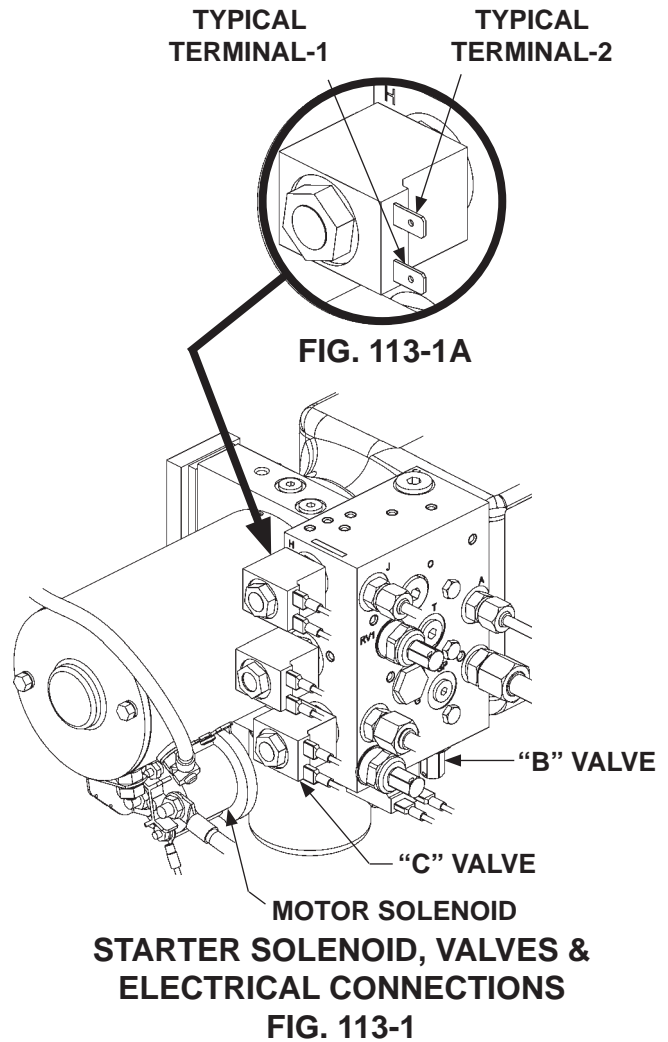

⚠ WARNING

Make sure Liftgate platform is open and resting on the ground before performing the following step.

CAUTION

To prevent damage when installing valve cartridges & coils, torque valve cartridge to 18.5-22 lb-in and coil nut to 3-4.5 lb-ft.

NOTE: Do the **BLEEDING HYDRAULIC SYSTEM** procedure in this manual with the following step.

3. Lower the platform to the ground. At the top of each column, loosen nut and disconnect hydraulic line from connector on bottom of flow control valve (**FIG. 114-1**). Check if the flow control valves are contaminated. Try to move plunger with small screwdriver through bottom of connector (**FIG. 114-1**). Replace valve if contaminated or not working.

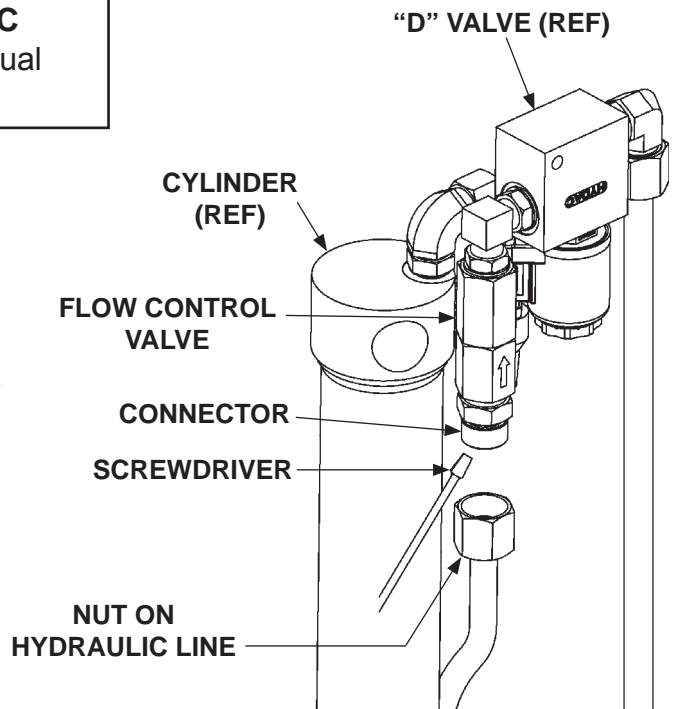

FIG. 114-1

TROUBLESHOOTING - POWER DOWN PLATFORM LOWERS SLOWLY (MTE PUMP)

NOTE: For dual pump system, check secondary pump and motor first.

NOTE: Numbers for the electrical terminals shown in the illustration are not stamped on valve coil. Numbers shown are for reference only.

1. Try lowering platform (control switch **DOWN**). Make sure starter solenoid (**FIG. 115-1**) is energized and “E” valve is not energized while lowering platform. Refer to **HYDRAULIC SYSTEM DIAGRAMS** in this manual.
2. Connect voltmeter to Terminal-1 and Terminal-2 on “E” valve shown in **FIG. 115-1A**. The correct indication on voltmeter is 0 volts DC when “E” valve is not energized. If the voltmeter indicates +11 to +12.6 volts DC, check control switch and wiring to “E” valve. Refer to **ELECTRICAL SYSTEM DIAGRAMS** in this manual. Replace faulty wiring or control switch as required.

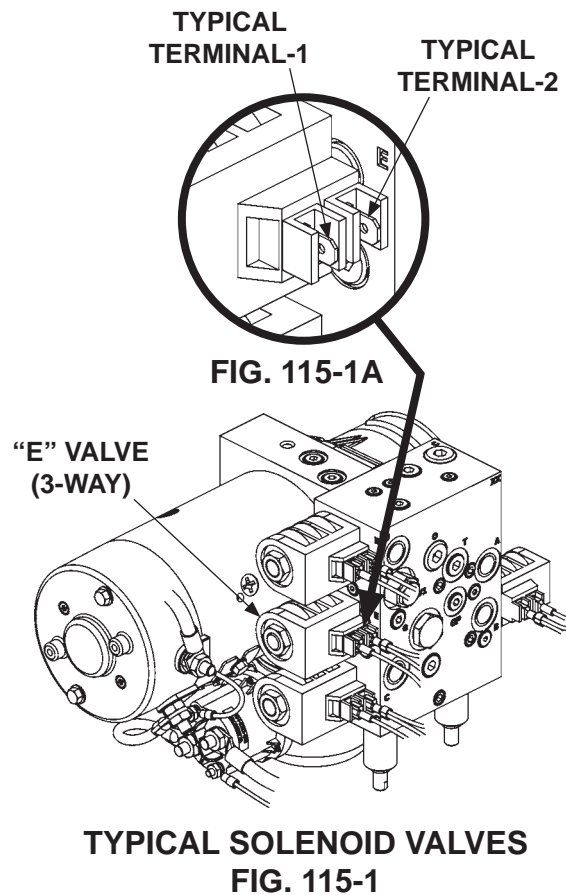

⚠ WARNING

Make sure Liftgate platform is open and resting on the ground before performing the following step.

CAUTION

To prevent damage when installing valve cartridges & coils, torque valve cartridge to 25-30 lb-ft and coil nut to 15-45 lb-in.

3. The “E” solenoid valve (**FIG. 116-1**) may be stuck in the “open” position. Remove the “E” solenoid valve (**FIG. 116-2**). Next, check the valve cartridge as follows. Push on the plunger in the valve by inserting a small screwdriver in the open end (**FIG. 116-3**). If the plunger does not move with a smooth, spring-loaded action (approximately 1/8”) (**FIG. 116-3**), replace the valve cartridge.
4. Reinstall “E” solenoid valve (if good) or a replacement. **Torque valve cartridge to 25-30 lb-ft and coil nut to 15-45 lb-in.**
5. Check for bent and broken parts on the Liftgate that could interfere with normal operation.
6. Check both flow control valves. Refer to the flow control valve instructions in the procedure for **PLATFORM RAISES AND LOWERS UNEVENLY**.

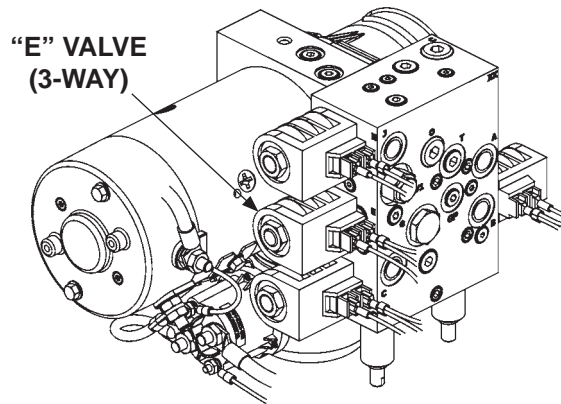
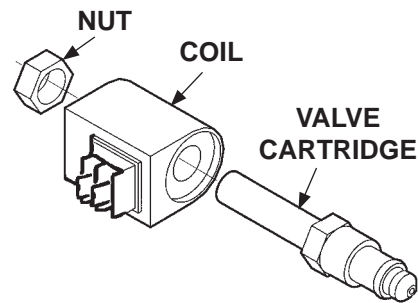
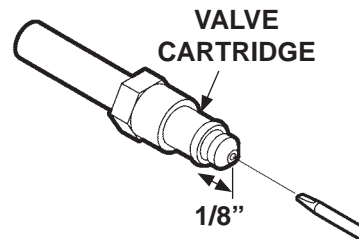

FIG. 116-1



**TYPICAL SOLENOID VALVE
REMOVED & DISASSEMBLED
FIG. 116-2**



**CHECKING VALVE CARTRIDGE
FIG. 116-3**

TROUBLESHOOTING - POWER DOWN PLATFORM LOWERS SLOWLY (BUCHER PUMP)

NOTE: For dual pump system, check secondary pump and motor first.

NOTE: Numbers for the electrical terminals shown in the illustration are not stamped on valve coil. Numbers shown are for reference only.

1. Try lowering platform (control switch **DOWN**). Make sure starter solenoid (**FIG. 117-1**) is energized and “E” valve is not energized while lowering platform. Refer to **HYDRAULIC SYSTEM DIAGRAMS** in this manual.
2. Connect voltmeter to Terminal-1 and Terminal-2 on “E” valve shown in **FIG. 117-1A**. The correct indication on voltmeter is 0 volts DC when “E” valve is not energized. If the voltmeter indicates +11 to +12.6 volts DC, check control switch and wiring to “E” valve. Refer to **ELECTRICAL SYSTEM DIAGRAMS** in this manual. Replace faulty wiring or control switch as required.

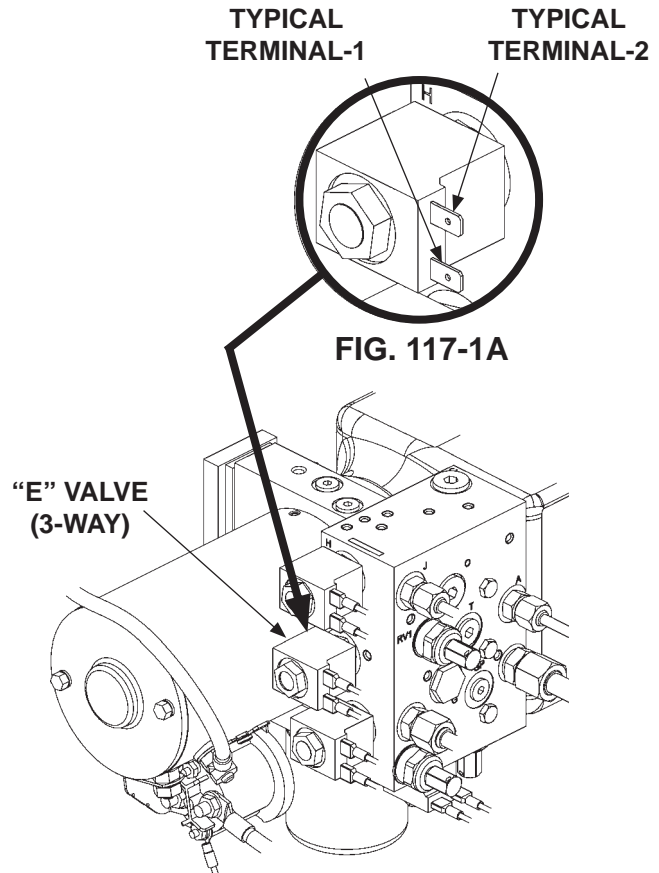

**TYPICAL SOLENOID VALVES
FIG. 117-1**

⚠ WARNING

Make sure Liftgate platform is open and resting on the ground before performing the following step.

CAUTION

To prevent damage when installing valve cartridges & coils, torque valve cartridge to 25-30 lb-ft and coil nut to 15-45 lb-in.

3. The “E” solenoid valve (**FIG. 118-1**) may be stuck in the “open” position. Remove the “E” solenoid valve (**FIG. 118-2**). Next, check the valve cartridge as follows. Push on the plunger in the valve by inserting a small screwdriver in the open end (**FIG. 118-3**). If the plunger does not move with a smooth, spring-loaded action (approximately 1/8”) (**FIG. 118-3**), replace the valve cartridge.
4. Reinstall “E” solenoid valve (if good) or a replacement. **Torque valve cartridge to 25-30 lb-ft and coil nut to 15-45 lb-in.**
5. Check for bent and broken parts on the Liftgate that could interfere with normal operation.
6. Check both flow control valves. Refer to the flow control valve instructions in the procedure for **PLATFORM RAISES AND LOWERS UNEVENLY**.

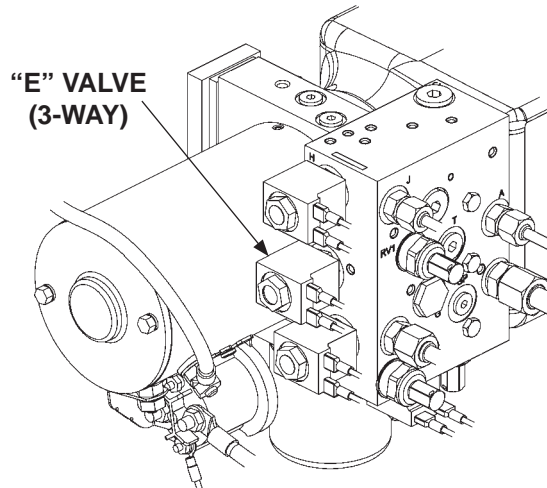
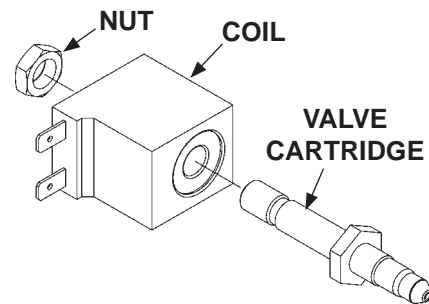
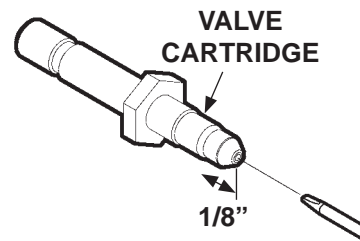

FIG. 118-1



**TYPICAL SOLENOID VALVE
REMOVED & DISASSEMBLED**

FIG. 118-2



CHECKING VALVE CARTRIDGE

FIG. 118-3

