

M-16-35  
REV B  
NOVEMBER 2017

# MAXON®

## TE-15 TE-20 TE-25 TE-30

### MAINTENANCE MANUAL

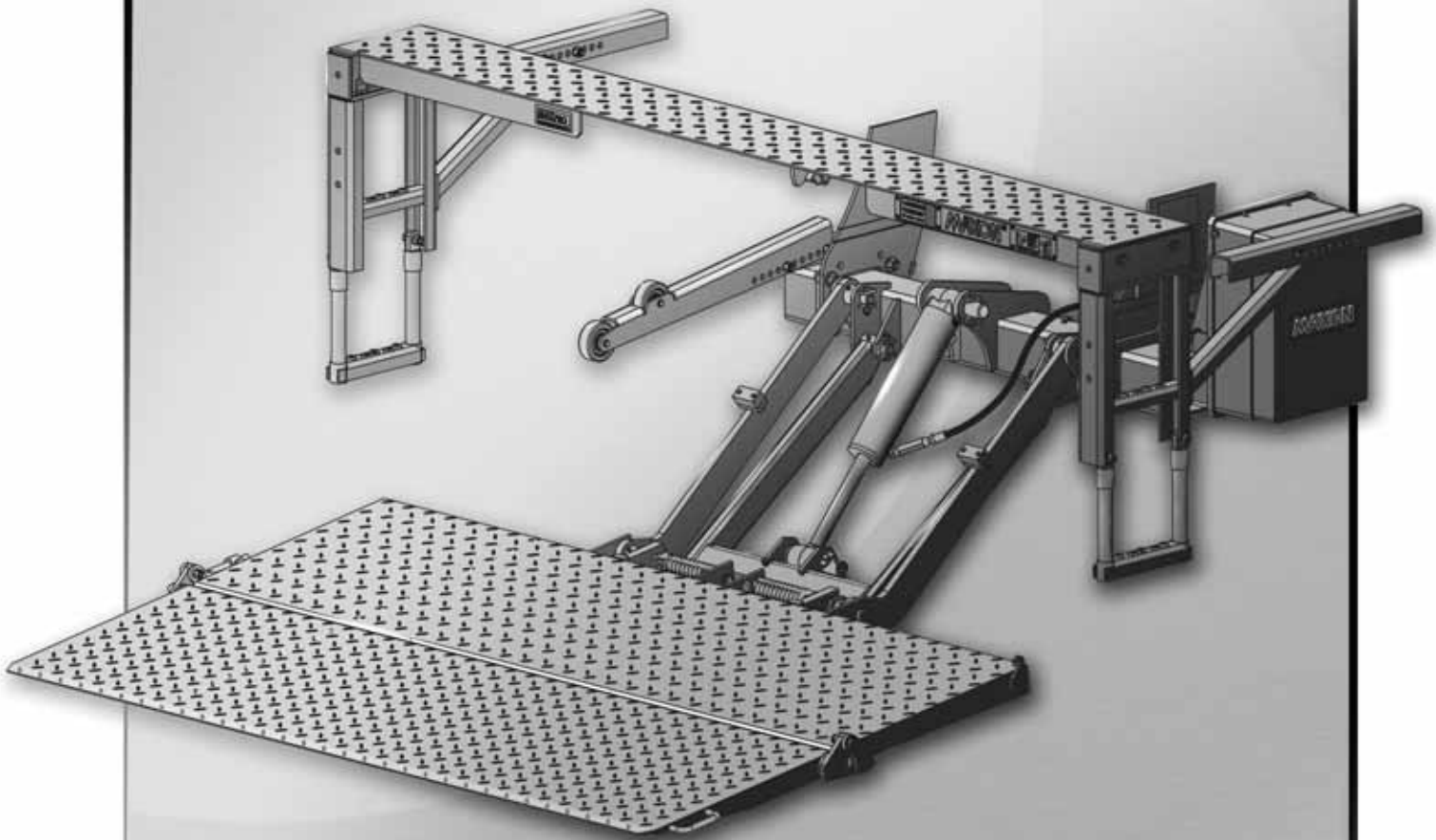



# MAXON<sup>®</sup>

## LIFT CORP.

11921 Slauson Ave.  
Santa Fe Springs, CA. 90670

### CUSTOMER SERVICE:

TELEPHONE (562) 464-0099 TOLL FREE (800) 227-4116

FAX: (888) 771-7713

NOTE: For latest version of all Manuals (and replacements), download the Manuals from Maxon's website at [www.maxonlift.com](http://www.maxonlift.com).

## WARRANTY/ RMA POLICY & PROCEDURE

### LIFTGATE WARRANTY

Type of Warranty: Full Parts and Labor

Term of Warranty: Standard Liftgates - 2 years from ship date or 6,000 cycles  
Premium Liftgates - 2 years from ship date or 10,000 cycles

This warranty shall not apply unless the product is installed, operated and maintained in accordance with MAXON Lift's specifications as set forth in MAXON Lift's Installation, Operation and Maintenance manuals. This warranty does not cover normal wear, maintenance or adjustments, damage or malfunction caused by improper handling, installation, abuse, misuse, negligence, or carelessness of operation. In addition, this warranty does not cover equipment that has had unauthorized modifications or alterations made to the product.

MAXON agrees to replace any components which are found to be defective during the first 2 years of service, and will reimburse for labor based on MAXON's Liftgate Warranty Flat Rate Schedule. (Copy of the Flat Rate is available at [www.maxonlift.com](http://www.maxonlift.com).)

All warranty repairs must be performed by an authorized MAXON warranty facility. For any repairs that may exceed \$500, including parts and labor, MAXON's Technical Service Department must be notified and an "Authorization Number" obtained.

All claims for warranty must be received within 30 Days of the repair date, and include the following information:

1. Liftgate Model Number and Serial Number
2. The End User must be referenced on the claim
3. Detailed Description of Problem
4. Corrective Action Taken, and Date of Repair
5. Parts used for Repair, Including MAXON Part Number(s)
6. MAXON R.M.A. # and/or Authorization # if applicable (see below)
7. Person contacted at MAXON if applicable
8. Claim must show detailed information i.e. Labor rate and hours of work performed

Warranty claims can also be placed online at [www.maxonlift.com](http://www.maxonlift.com). Online claims will be given priority processing.

All claims for warranty will be denied if paperwork has not been received or claim submitted via Maxon website for processing by MAXON's Warranty Department within 30 days of repair date.

All components may be subject to return for inspection, prior to the claim being processed. MAXON products may not be returned without prior written approval from MAXON's Technical Service Department. Returns must be accompanied by a copy of the original invoice or reference with original invoice number and are subject to a credit deduction to cover handling charges and any necessary reconditioning costs. **Unauthorized returns will be refused and will become the responsibility of the returnee.**

Any goods being returned to MAXON Lift must be pre-approved for return, and have the R.M.A. number written on the outside of the package in plain view, and returned freight prepaid. All returns are subject to a 15% handling charge if not accompanied by a detailed packing list. Returned parts are subject to no credit and returned back to the customer. Defective parts requested for return must be returned within 30 days of the claim date for consideration to:

MAXON Lift Corp.  
10321 Greenleaf Ave., Santa Fe Springs, CA 90670  
Attn: RMA# \_\_\_\_\_

MAXON's warranty policy does not include the reimbursement for travel time, towing, vehicle rental, service calls, oil, batteries or loss of income due to downtime. Fabrication or use of non Maxon parts, which are available from MAXON, are also not covered.

MAXON's Flat Rate Labor Schedule takes into consideration the time required for diagnosis of a problem.

All Liftgates returned are subject to inspection and a 15% restocking fee. Any returned Liftgates or components that have been installed or not returned in new condition will be subject to an additional reworking charge, which will be based upon the labor and material cost required to return the Liftgate or component to new condition.

### PURCHASE PART WARRANTY

Term of Warranty: 1 Year from Date of Purchase.

Type of Warranty: Part replacement only. MAXON will guarantee all returned genuine MAXON replacement parts upon receipt and inspection of parts and original invoice.

All warranty replacements parts will be sent out via ground freight. If a rush shipment is requested, all freight charges will be billed to the requesting party.

# TABLE OF CONTENTS

<b>SUMMARY OF CHANGES: M-16-35, REVISION B</b> .....	<b>6</b>
<b>WARNINGS</b> .....	<b>7</b>
<b>SAFETY INSTRUCTIONS</b> .....	<b>8</b>
LIFTGATE TERMINOLOGY .....	9
<b>PERIODIC MAINTENANCE</b> .....	<b>10</b>
PERIODIC MAINTENANCE CHECKS .....	10
PERIODIC MAINTENANCE CHECKLIST .....	11
CHECKING HYDRAULIC FLUID .....	13
CHANGING HYDRAULIC FLUID .....	15
PLATFORM ADJUSTMENT .....	18
REPLACING PLATFORM TORSION SPRING .....	21
SAFETY HOOK MAINTENANCE .....	23
<b>DECALS &amp; PLATES</b> .....	<b>24</b>
PUMP, MOTOR & SOLENOID OPERATION - GRAVITY DOWN .....	26
PUMP, MOTOR & SOLENOID OPERATION - POWER DOWN .....	27
<b>HYDRAULIC SYSTEM DIAGRAMS</b> .....	<b>28</b>
HYDRAULIC SCHEMATIC (GRAVITY DOWN).....	28
HYDRAULIC SCHEMATIC (POWER DOWN) .....	29
<b>ELECTRICAL SYSTEM DIAGRAMS</b> .....	<b>30</b>
ELECTRICAL SCHEMATIC (GRAVITY DOWN) .....	30
ELECTRICAL SCHEMATIC (POWER DOWN) .....	31
TE SERIES ELECTRICAL VALUES.....	32
<b>TROUBLESHOOTING</b> .....	<b>33</b>
PLATFORM WILL NOT RAISE.....	33
PLATFORM RAISES BUT LEAKS DOWN .....	34

PLATFORM RAISES PARTIALLY AND STOPS.....	35
LIFTGATE WILL NOT LIFT RATED CAPACITY.....	36
PLATFORM RAISES SLOWLY .....	37
PLATFORM WILL NOT LOWER, LOWERS TOO SLOWLY OR TOO QUICKLY.....	38

## SUMMARY OF CHANGES: M-16-35, REVISION B

PAGE	DESCRIPTION OF CHANGE
Cover	Includes TE-15 and TE-20 liftgates.
14	Combined EXXON & MOBIL oils on the same row with updated part numbers.
29	Updated power down hydraulic schematic shows solenoid valves S1 & S2.
30, 31	Gravity down and power down electrical schematics are updated to same level of details as installation manual.
32	Added TE Series electrical values.

**MAXON**<sup>®</sup>

11921 Slauson Ave. Santa Fe Springs, CA. 90670 (800) 227-4116 FAX (888) 771-7713

Comply with the following **WARNINGS** and **SAFETY INSTRUCTIONS** while maintaining Liftgates. See Operation Manual for operating safety requirements.

## **WARNING**

- Do not stand, or allow obstructions, under the platform when lowering the Liftgate. **Be sure your feet are clear of the Liftgate.**
- **Keep fingers, hands, arms, legs, and feet clear of moving Liftgate parts (and platform edges) when operating the Liftgate.**
- **Correctly stow platform when not in use. Extended platforms could create a hazard for people and vehicles passing by.**
- **Disconnect Liftgate power cable from battery** before repairing or servicing Liftgate.
- If it is necessary to stand on the platform while maintaining the Liftgate, keep your feet and any objects clear of the inboard edge of the platform. Your feet or objects on the platform can become trapped between the platform and the Liftgate extension plate.
- Recommended practices for welding on steel parts are contained in the current **AWS (American Welding Society) D1.1 Structural Welding Code - Steel**. Damage to Liftgate and/or vehicle, and personal injury could result from welds that are done incorrectly.
- Recommended practices for welding on aluminum parts are contained in the current **AWS (American Welding Society) D1.2 Structural Welding Code - Aluminum**. Damage to Liftgate and/or vehicle, and personal injury could result from welds that are done incorrectly.
- Recommended practices for welding galvanized steel are contained in the current **AWS (American Welding Society) D19.0 Welding Zinc-Coated Steel**. Damage to Liftgate and/or vehicle, and personal injury can result from welds that are done incorrectly.

## SAFETY INSTRUCTIONS

- Read and understand the instructions in this **Maintenance Manual** before performing maintenance on the Liftgate.
- Before operating the Liftgate, read and understand the operating instructions in **Operation Manual**.
- Comply with all **WARNING** and instruction decals attached to the Liftgate.
- Keep decals clean and legible. If decals are illegible or missing, replace them. Free replacement decals are available from **Maxon Customer Service**.
- Consider the safety and location of bystanders and location of nearby objects when operating the Liftgate. Stand to one side of the platform while operating the Liftgate.
- Do not allow untrained persons to operate the Liftgate.
- Wear appropriate safety equipment such as protective eyeglasses, faceshield and clothing while performing maintenance on the Liftgate and handling the battery. Debris from drilling and contact with battery acid may injure unprotected eyes and skin.
- Be careful working by an automotive type battery. Make sure the work area is well ventilated and there are no flames or sparks near the battery. Never lay objects on the battery that can short the terminals together. If battery acid gets in your eyes, immediately seek first aid. If acid gets on your skin, immediately wash it off with soap and water.
- If an emergency situation arises (vehicle or Liftgate) while operating the Liftgate, release the control switch to stop the Liftgate.
- A correctly installed Liftgate operates smoothly and reasonably quiet. The only noticeable noise during operation comes from the power unit while the platform is raised. Listen for scraping, grating and binding noises and correct the problem before continuing to operate Liftgate.
- Use only **Maxon Authorized Parts** for replacement parts. Provide Liftgate model and serial number information with your parts order. Order replacement parts from:

**MAXON LIFT CORP. Customer Service**  
**11921 Slauson Ave., Santa Fe Springs, CA 90670**

**Online: [www.maxonlift.com](http://www.maxonlift.com)**  
**Express Parts Ordering: Phone (800) 227-4116 ext. 4345**  
**Email: Ask your Customer Service representative**

**MAXON**<sup>®</sup>

11921 Slauson Ave. Santa Fe Springs, CA. 90670 (800) 227-4116 FAX (888) 771-7713



# LIFTGATE TERMINOLOGY

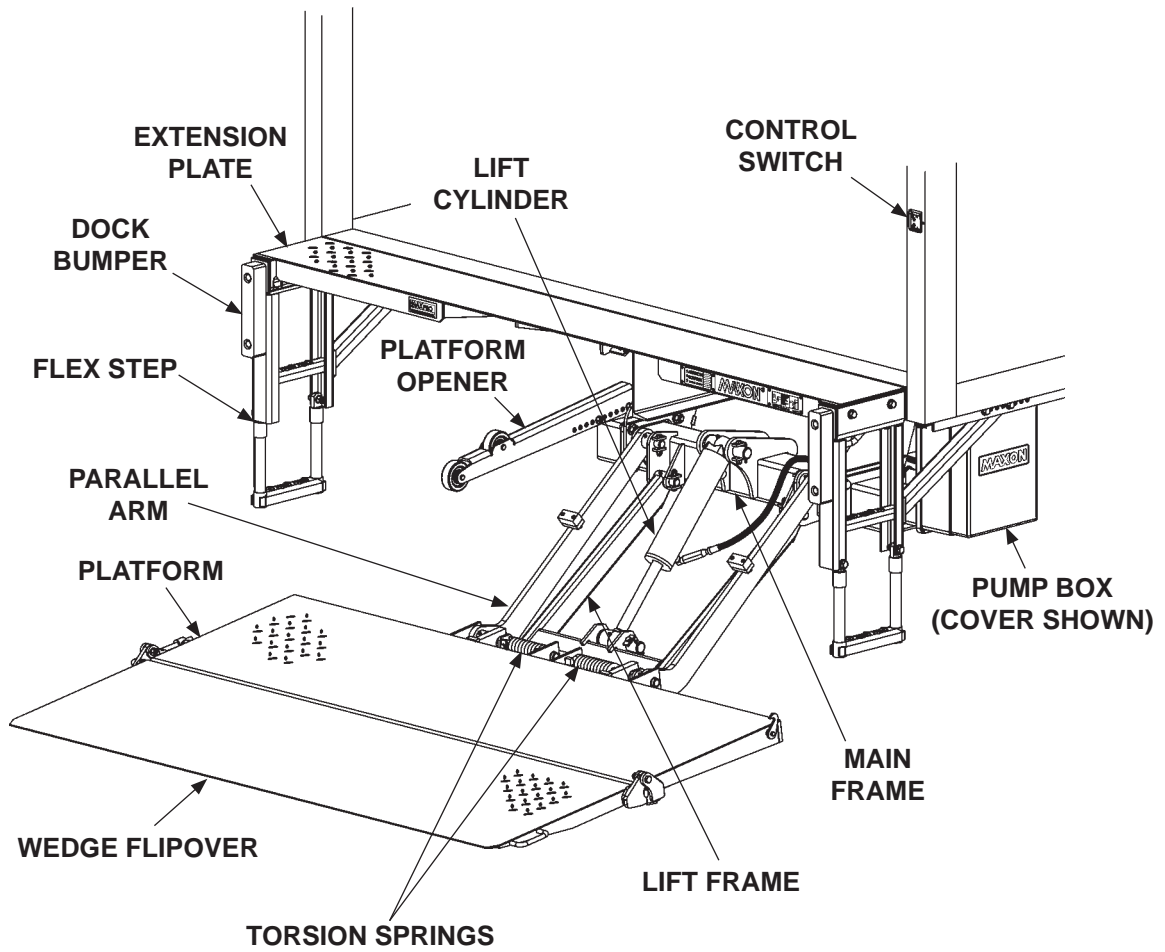

## PERIODIC MAINTENANCE PERIODIC MAINTENANCE CHECKS

### ⚠ WARNING

Never operate the Liftgate if parts are loose or missing.

**NOTE:** Make sure vehicle is parked on level ground while performing the maintenance checks.

### Quarterly or 1250 Cycles (whichever occurs first)

Check the hydraulic fluid level in the pump reservoir. Refer to the **CHECKING HYDRAULIC FLUID** procedure in the **PERIODIC MAINTENANCE** section.

If hydraulic fluid appears contaminated, refer to the **CHANGING HYDRAULIC FLUID** procedure in the **PERIODIC MAINTENANCE** section.

Keep track of the grade of hydraulic fluid in the pump reservoir and never mix two different grades of fluid.

Check all hoses and fittings for chafing and fluid leaks. Tighten loose fittings or replace parts as required.

Check electrical wiring for chafing and make sure wiring connections are tight and free of corrosion. Use dielectric grease to protect electrical connections.

Check that all **WARNING and instruction decals** are in place. Also, make sure decals are legible, clean and undamaged.

Check that all bolts, nuts, and roll pins are in place. Make sure roll pins protrude evenly from both sides of hinge pin collar. Replace fasteners and roll pins if necessary.

Pump EP chassis grease in each lube fitting on the cylinders and arms until grease starts oozing from ends of the bearings. The lubrication diagram on the **PERIODIC MAINTENANCE CHECKLIST SHEET** shows where to find the lube fittings. Wipe off excess grease with a clean lint-free cloth.

### CAUTION

Damaged cylinder seals and contaminated hydraulic fluid can result from painting the polished portion of the cylinder rod. To prevent damage, protect the exposed polished portion of the cylinder rod while painting.

Check for rust and oily surfaces on Liftgate. If there is rust or oil on Liftgate, clean it off. Touch up the paint or galvanized finish where bare metal is showing. **MAXON** recommends using the aluminum primer touchup paint or cold galvanize spray for galvanized finish.

### Semi-annually or 2500 Cycles (whichever occurs first)

Visually check the platform hinge pins for excessive wear and broken welds. See **PARTS BREAKDOWN** section for replacement parts. Also, do the **Quarterly or 1250 Cycles** maintenance checks.

**MAXON**<sup>®</sup>

11921 Slauson Ave. Santa Fe Springs, CA 90670 (800) 227-4116 FAX (888) 771-7713

## PERIODIC MAINTENANCE CHECKLIST

**NOTE:** Make sure vehicle is parked on level ground while performing the maintenance checks.

### Quarterly or 1250 Cycles (whichever occurs first)

- Check the level and condition of the hydraulic fluid.
- Visually check all hoses for chafing and fluid leaks. Tighten loose fittings or replace parts as required.
- Check electrical wiring for chafing and make sure wiring connections are tight and free of corrosion. Use dielectric grease to protect electrical connections.
- Check that all **WARNING and instruction decals** are in place. Also, make sure decals are legible and decals are clean and undamaged.
- Check that all bolts, nuts, and roll pins are in place. Make sure roll pins protrude evenly from both sides of hinge pin collar. Replace fasteners and roll pins if necessary.
- Pump EP chassis grease in each lube fitting on the cylinders and arms until grease starts oozing from ends of the bearings. Refer to lubrication diagram on the next page. Wipe off excess grease with a clean lint-free cloth.

### CAUTION

**Damaged cylinder seals and contaminated hydraulic fluid can result from painting the polished portion of the cylinder rod. To prevent damage, protect the exposed polished portion of the cylinder rod while painting.**

- Check for rust and oily surfaces on Liftgate. If there is rust or oil on Liftgate or if the Lift-gate is dirty, clean it off. Touch up the paint or galvanized finish where bare metal is showing. To maintain the protection provided by the original paint system or galvanized finish, **MAXON** recommends using the aluminum primer touchup paint or cold galvanize spray for galvanized finish.

### Semi-annually or 2500 Cycles (whichever occurs first)

- Visually check the platform hinge pins for excessive wear and broken welds.
- Do the **Quarterly or 1250 Cycles Checks** on this checklist.

# PERIODIC MAINTENANCE

## PERIODIC MAINTENANCE CHECKLIST - Continued

**NOTE:** Lube fittings are shown for the cylinder, LH lift arm, and LH parallel arm. There are also lube fittings at the same places on the RH cylinder, lift arm, and parallel arm.

Refer to lubrication diagram (**FIG. 12-1**) to find the lube fittings on cylinders and arms. Pump EP chassis grease in each lube fitting on the cylinders and arms until grease starts oozing from ends of the bearings. Then, wipe off excess grease with a clean lint-free cloth.

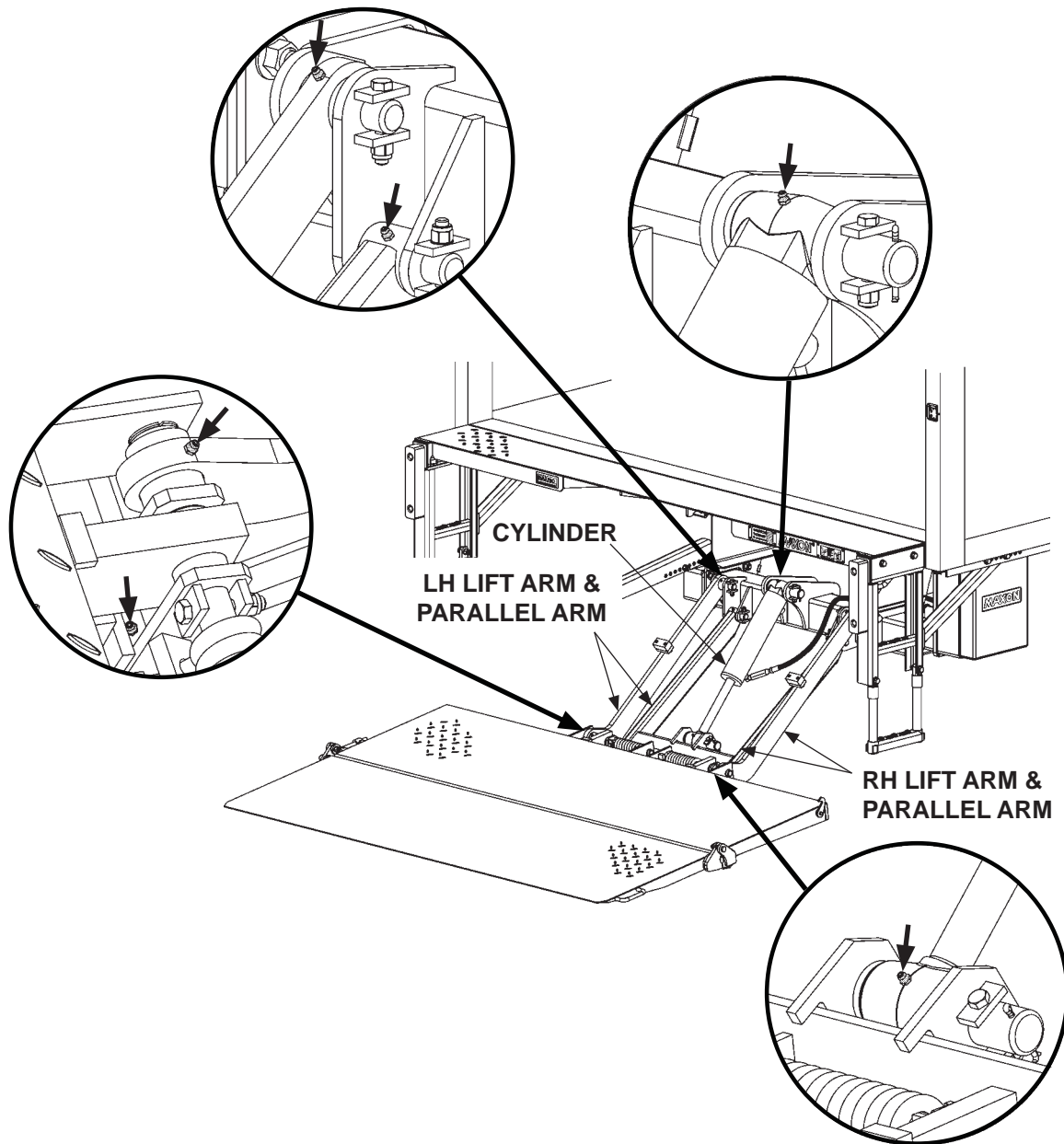

**LUBRICATION DIAGRAM**  
**FIG. 12-1**

## CHECKING HYDRAULIC FLUID

### CAUTION

Keep dirt, water and other contaminants from entering the hydraulic system. Before opening the hydraulic fluid reservoir filler cap, drain plug and hydraulic lines, clean up contaminants that can get in the openings. Also, protect the openings from accidental contamination.

**NOTE:** Liftgate is shipped with **ISO 32** oil. Use correct oil for climate conditions.  
**+50 to +120 Degrees F - Grade ISO 32**  
**Below + 70 Degrees F - Grade ISO 15 or MIL-H-5606**  
See **TABLES 14-1 & 14-2** for recommended brands of **ISO 32 & ISO 15** oils.

**NOTE:** Hydraulic oil level must be minimum of 1-1/2" above the bottom of reservoir to operate Liftgate.

1. With platform at bed height, check oil level in the pump reservoir (**FIG. 13-1**). To add oil, pull out filler cap (no threads) (**FIG. 13-1**). Add hydraulic oil in reservoir to the level shown in **FIG. 13-1**.

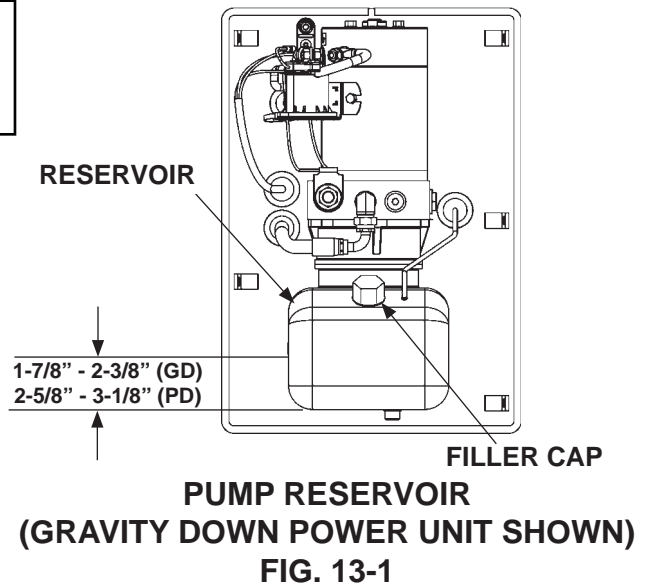

2. Reinstall filler cap (**FIG. 13-1**).

3. Bolt on the pump cover as shown in **FIG. 13-2**. Torque the bolts (cap screws) to **10 - 14 lb-in.**

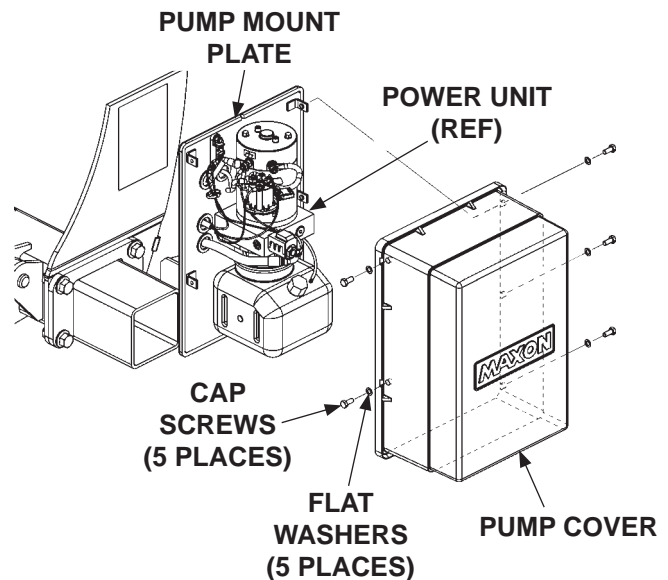

**BOLTING ON PUMP COVER**  
**FIG. 13-2**

# PERIODIC MAINTENANCE

## CHECKING HYDRAULIC FLUID - Continued

ISO 32 HYDRAULIC OIL	
RECOMMENDED BRANDS	PART NUMBER
CHEVRON	HIPERSYN 32
KENDALL	GOLDEN MV
SHELL	TELLUS S2 VX 32
EXXONMOBIL	UNIVIS N-32, DTE-24

**TABLE 14-1**

ISO 15 OR MIL-H-5606 HYDRAULIC OIL	
RECOMMENDED BRANDS	PART NUMBER
CHEVRON	FLUID A, AW-MV-15
KENDALL	GLACIAL BLU
SHELL	TELLUS S2 VX 15
EXXONMOBIL	UNIVIS HVI-13
ROSEMEAD	THS FLUID 17111

**TABLE 14-2**

**MAXON®**

11921 Slauson Ave. Santa Fe Springs, CA. 90670 (800) 227-4116 FAX (888) 771-7713

## CHANGING HYDRAULIC FLUID

### CAUTION

Keep dirt, water and other contaminants from entering the hydraulic system. Before opening the hydraulic fluid reservoir filler cap, drain plug and hydraulic lines, clean up contaminants that can get in the openings. Also, protect the openings from accidental contamination.

**NOTE:** Liftgate is shipped with **ISO 32** oil. Use correct oil for climate conditions.  
**+50 to +120 Degrees F - Grade ISO 32**  
**Below + 70 Degrees F - Grade ISO 15 or MIL-H-5606**  
See **TABLES 14-1 & 14-2** for recommended brands of **ISO 32 & ISO 15** oils.

### GRAVITY DOWN LIFTGATES

1. Remove the pump cover (**FIG. 13-1**). Place empty 5 gallon bucket under drain plug (**FIG. 15-1**).
2. Lower platform to ground. Pull out (no threads) drain plug (**FIG. 15-1**). Drain hydraulic fluid from system. Reinstall drain plug.
3. Pull out (no threads) filler cap (**FIG. 15-1**) and refill reservoir with hydraulic fluid to level shown in **FIG. 15-1**. Reinstall filler cap (**FIG. 15-1**).
4. Bolt on the pump cover as shown in **FIG. 16-1**. Torque the bolts (cap screws) to **10-14 lb-in.**

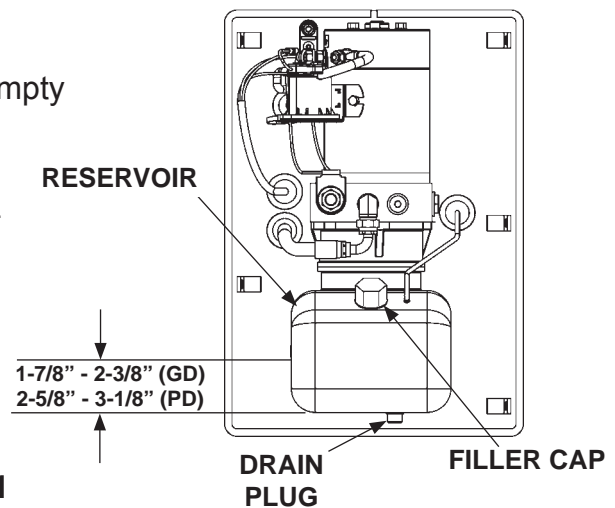

**LIFTGATE SHOWN WITH GRAVITY DOWN PUMP & MOTOR**  
**FIG. 15-1**

### POWER DOWN LIFTGATES

1. Remove the pump cover (**FIG. 13-1**). Place empty 5 gallon bucket under drain plug (**FIG. 15-1**).
2. Open and raise platform to vehicle bed height. Pull out (no threads) drain plug (**FIG. 15-1**). Drain hydraulic fluid.
3. Disconnect the white wire (**FIG. 15-2**) from starter solenoid. Lower the platform while draining the remaining hydraulic fluid from system. Reinstall drain plug. Reconnect the white wire to starter solenoid.
4. Pull out (no threads) filler cap (**FIG. 15-1**) and refill reservoir with hydraulic fluid to level shown in **FIG. 15-1**. Reinstall filler cap (**FIG. 15-1**).

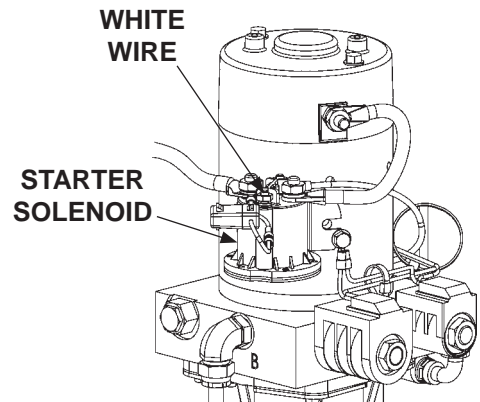

**POWER DOWN PUMP**  
**FIG. 15-2**

## PERIODIC MAINTENANCE CHANGING HYDRAULIC OIL - Continued

5. Bolt on the pump cover as shown in **FIG. 16-1**. Torque the cap screws to **10-14 lb-in.**

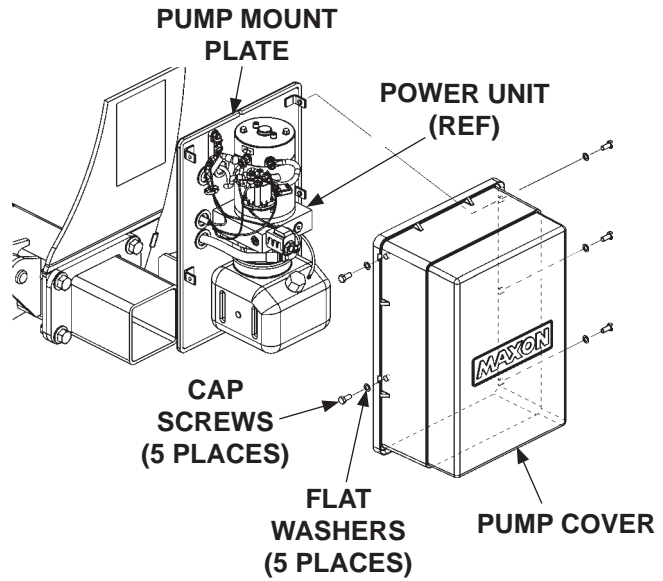

**BOLTING PUMP COVER  
FIG. 16-1**

**MAXON**<sup>®</sup>

11921 Slauson Ave. Santa Fe Springs, CA. 90670 (800) 227-4116 FAX (888) 771-7713



**THIS PAGE INTENTIONALLY LEFT BLANK**

# PERIODIC MAINTENANCE PLATFORM ADJUSTMENT

**NOTE:** Before doing the following procedure, make sure vehicle is parked on level ground.

1. Make sure platform is at ground level. Unfold the platform and flipover. As the platform first touches the ground, shackles and tip of flipover must touch the ground at the same time (**FIG. 18-1**). If the shackles and the tip of flipover touch the ground at the same time, raise platform to bed height. Outboard edge on top of flipover should be above bed level (**FIG. 18-2**). If indications are correct in both cases (**FIGS. 18-1 & 18-2**), Liftgate is installed correctly and no adjustment is needed. If indications are incorrect, continue with instruction 2.

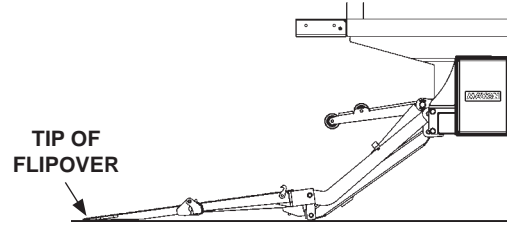

**PLATFORM & SHACKLES  
TOUCH GROUND  
FIG. 18-1**

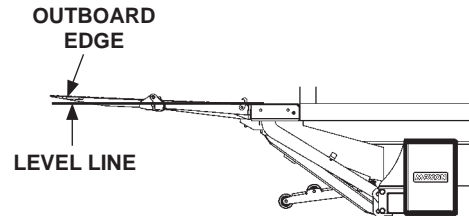

**PLATFORM EDGE  
ABOVE BED LEVEL  
FIG. 18-2**

**NOTE:** If tip of flipover touches first (**FIG. 18-3A**), do instructions 2 and 3. If the shackle touches first (see **FIG. 20-1**), skip 2 and 3 and do instructions 4 and 5.

2. Make sure platform is still at ground level. If the shackle is not touching the ground, measure and compare distance "A" (**FIG. 18-3A**) with **TABLE 18-1** to determine the correct shim. Next, mark position on shackle (**FIG. 18-3B**).

RAISE TIP OF FLIPOVER THIS DISTANCE "A"	REQUIRED SHIM THICKNESS	WELD SIZE "W"
9/16"	1/16"	1/16"
1-1/4"	1/8"	1/8"
1-15/16"	3/16"	3/16"
2-5/8"	1/4"	1/4"

**SHIMS TO RAISE TIP OF FLIPOVER  
TABLE 18-1**

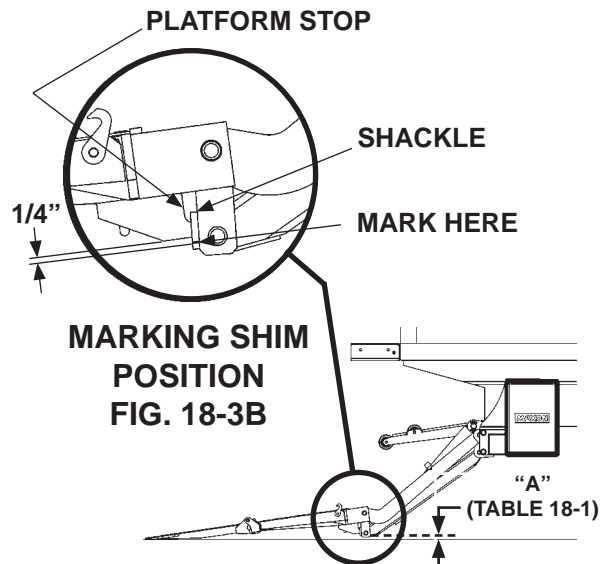

**SHACKLES DO NOT TOUCH GROUND  
FIG. 18-3A**

3. Make shims as needed (**FIG. 19-1**). Position bottom edge of shim to line up with mark on shackle (**FIG. 19-2**). Then, weld the shim to shackle as shown in **FIG. 19-2**.

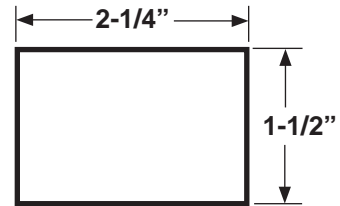

**SHIM (1/16", 1/8", 3/16", or 1/4")  
MADE FROM STEEL FLAT  
FIG. 19-1**

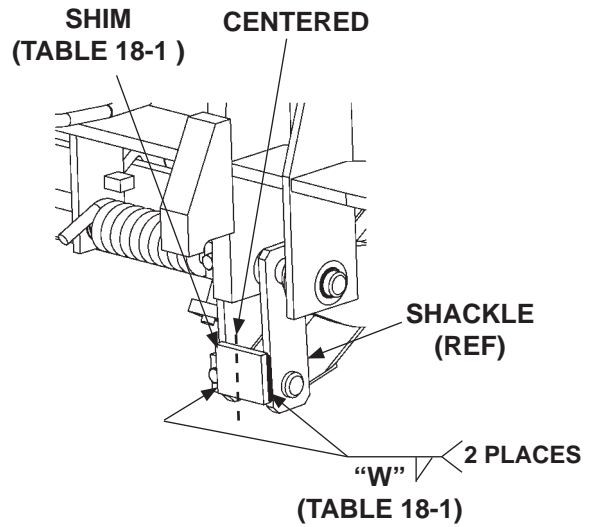

**WELDING SHIMS (RH SHACKLE SHOWN)  
FIG. 19-2**

# PERIODIC MAINTENANCE

## PLATFORM ADJUSTMENT - Continued

4. Make sure platform is still at ground level. If the tip of flipover is not touching the ground, measure and compare distance "B" (FIG. 20-1) with TABLE 20-1 to determine how much to grind from the platform stops (FIG. 20-2).

LOWER TIP OF FLIPOVER THIS DISTANCE "B"	GRIND METAL FROM PLATFORM STOP
9/16"	1/16"
1-1/4"	1/8"
1-15/16"	3/16"
2-5/8"	1/4"

**GRIND TO LOWER TIP**  
**TABLE 20-1**

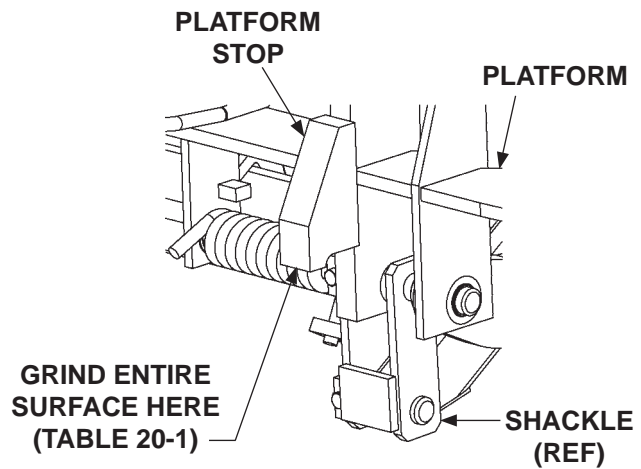
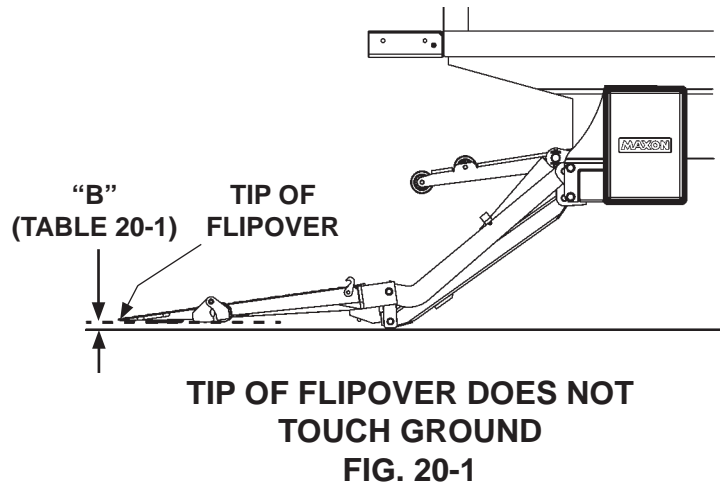

5. Grind correct amount of metal (TABLE 20-1) from platform stop as shown in FIG. 20-2.

6. Raise the platform, then lower it to the ground. As the platform first touches the ground, the tip of flipover and shackle should touch at the same time as shown in FIG. 20-3.

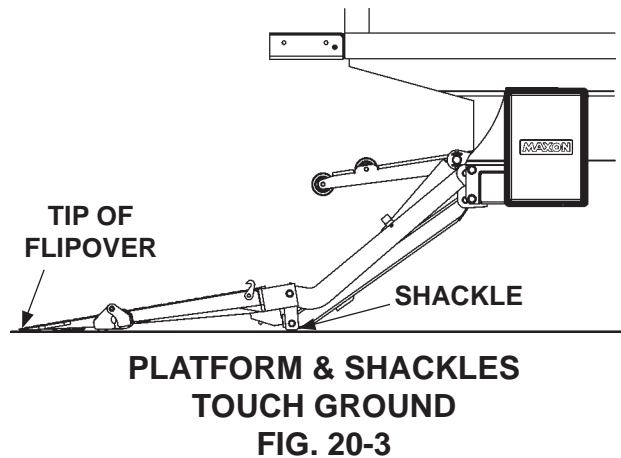

## REPLACING PLATFORM TORSION SPRING

1. Fold flipover onto platform.
2. Fold platform.
3. Raise Liftgate to a convenient work height to gain access and release tension on the torsion spring.

### **CAUTION**

To prevent injury and equipment damage, make sure there is no tension on torsion spring before removing hinge pin.

4. Remove cap screw, flat washer and locknut from pin collar on the platform hinge bracket. Drive the platform hinge pin outboard from the shackle just enough to free the torsion spring (**FIG. 21-1**). Remove torsion spring.

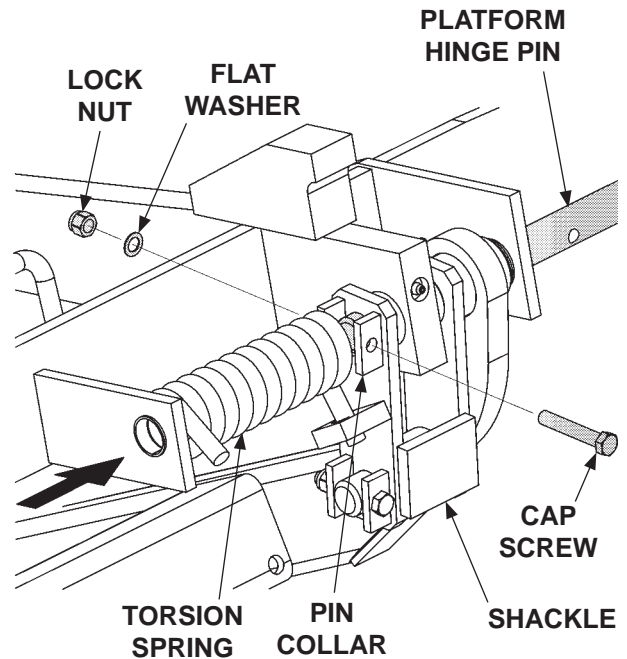

**FIG. 21-1**

5. Install the torsion spring as shown in (**FIG. 21-2**). Make sure the long leg of the spring is inserted through the hole in the block on the shackle (**FIG. 21-2**). Make sure the short end of the spring is positioned as shown in **FIG. 21-2**.

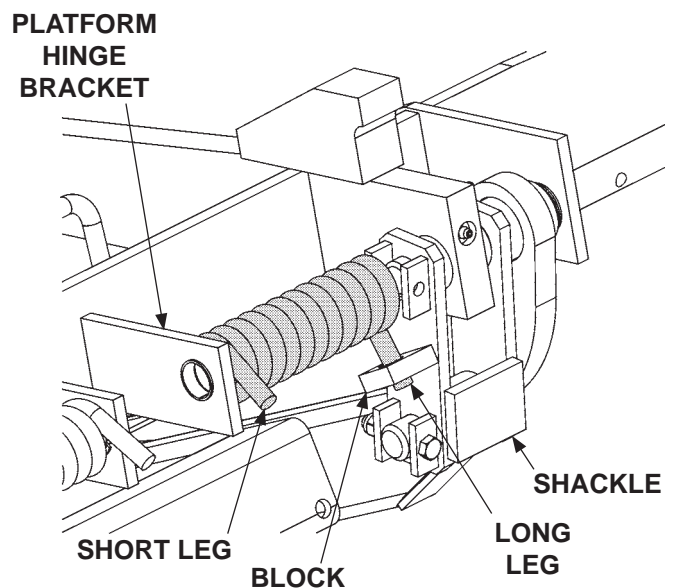
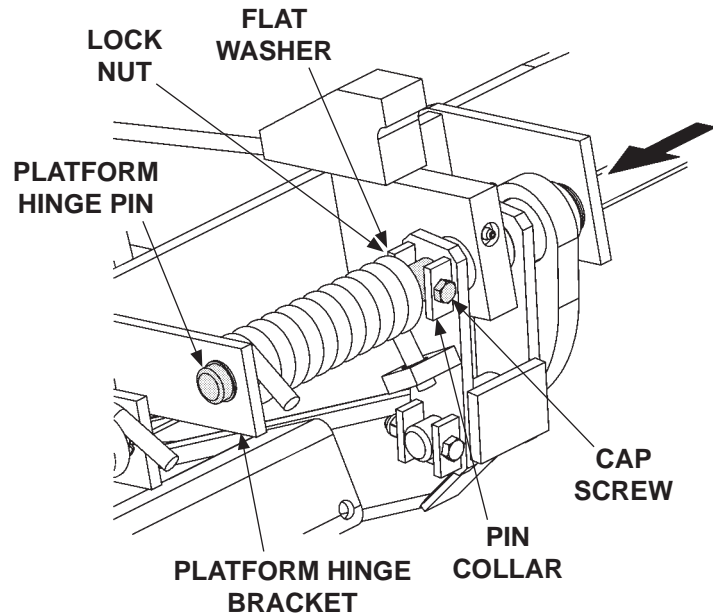

**FIG. 21-2**

## PERIODIC MAINTENANCE

### REPLACING PLATFORM TORSION SPRING - Continued

6. Drive platform hinge pin inboard to correct position through the platform hinge bracket (**FIG. 22-1**). Line up the hole in the platform hinge pin with the hole in the pin collar. Reinstall cap screw through the pin collar and secure with flat washer and locknut (**FIG. 22-1**).



**FIG. 22-1**

**MAXON**<sup>®</sup>

11921 Slauson Ave. Santa Fe Springs, CA. 90670 (800) 227-4116 FAX (888) 771-7713

## SAFETY HOOK MAINTENANCE

### CHECK SAFETY HOOK FUNCTION

1. When raising platform to stowed position, listen for sound of **safety hook** engaging **platform loop**.
2. When the Liftgate is stowed, see if **platform loop** is seated in the **safety hook** as shown in **FIG. 23-1**.

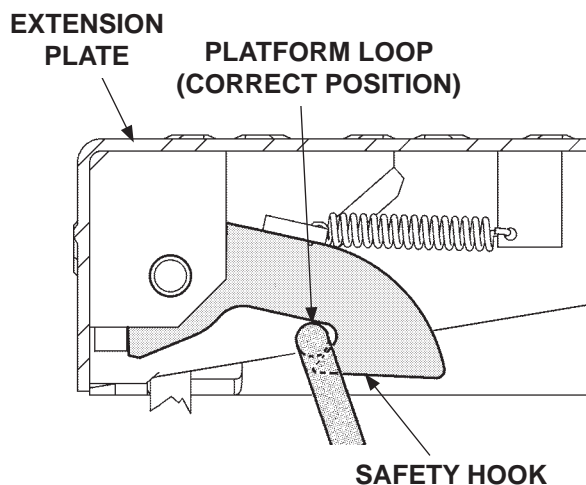

**PLATFORM LOOP SHOWN HOOKED  
IN CORRECT POSITION  
FIG. 23-1**

### LOOP ADJUSTMENT

1. If the safety hook is not positioned correctly (**FIG. 23-2**), lower platform enough to access the safety hook. (**See Operation Manual for instructions to lower the platform.**)
2. Adjust by bending the platform loop so it seats correctly in the hook as shown in **FIG. 23-2**.
3. Stow the platform and check for correct safety hook position (**FIG. 23-2**). Repeat adjustment if required.

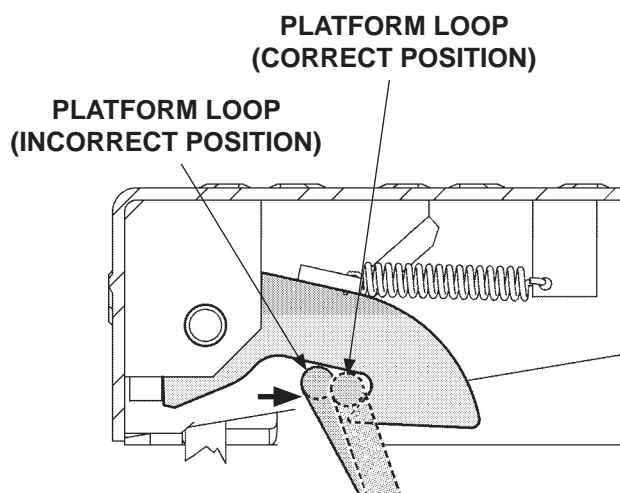

**PLATFORM LOOP SHOWN HOOKED  
INCORRECTLY  
FIG. 23-2**

# DECALS & PLATES

**NOTE:** Ensure there is no residue, dirt or corrosion where decals are attached. If necessary, clean surface before attaching decals.

**NOTE:** Preferred decal layout is shown, Decals on the Liftgate are attached at the factory. If vehicle does not permit this layout, decals in the manual and decal kit must be applied so that they are easily visible when approaching vehicle to operate Liftgate. Use good common sense when locating these decals on vehicle.

**MAXON**<sup>®</sup>

11921 Slauson Ave. Santa Fe Springs, CA. 90670 (800) 227-4116 FAX (888) 771-7713

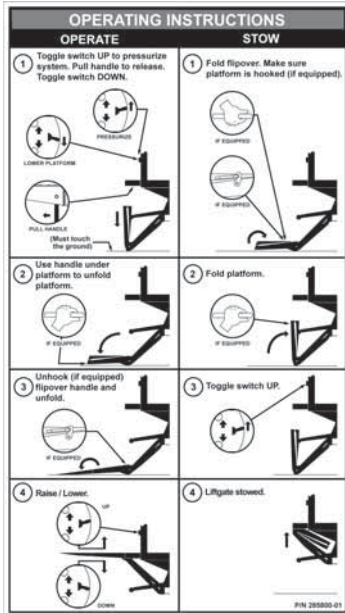

**INSTRUCTION DECAL**  
P/N 285800-01

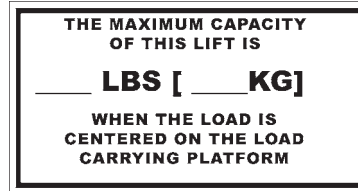

**CAPACITY DECAL**  
(REFER TO TABLE 25-1)

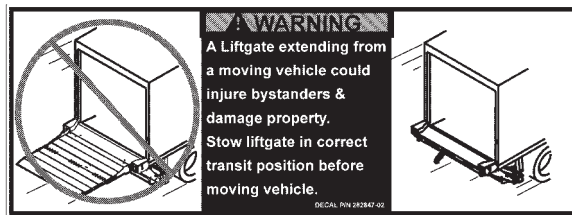

**STOW WARNING DECAL**  
P/N 282847-02

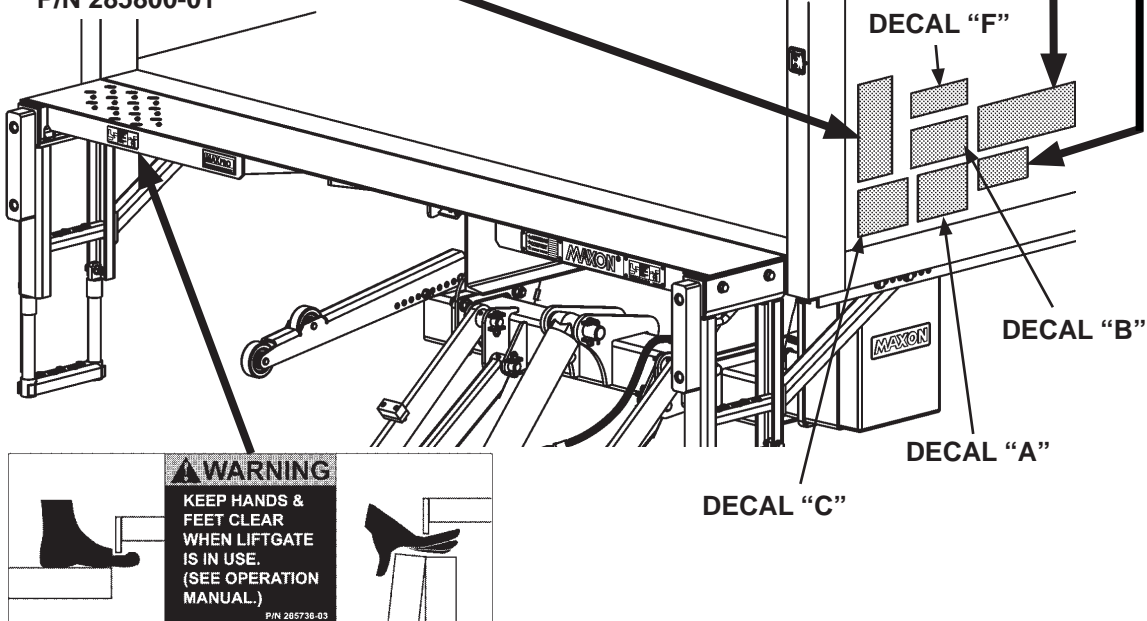

**WARNING DECAL**  
P/N 265736-03

**FIG. 24-1**



**CAUTION**

**Always stand clear of platform area.**

P/N 282522-01 **F**

**WARNING**

**Read this information carefully.**

- Improper operation of this Liftgate can result in serious personal injury. If you do not have a copy of the operating instructions, please obtain them from your employer, distributor, or lessor before you attempt to operate Liftgate.
- If there are signs of improper maintenance, damage to vital parts, or slippery platform surface, do not use the Liftgate until these problems have been corrected.
- If you are using a pallet jack, be sure it can be maneuvered safely.
- Do not operate a forklift on the platform.
- Do not allow any part of yours or your helper's body to be placed under, within, or around any portion of the moving Liftgate, or its mechanisms, or in a position that would trap them between the platform and the ground or truck when the Liftgate is operated.
- If a helper is riding the platform with you, make sure you are both doing so safely and that you are not in danger of coming in contact with any moving or potentially moving obstacles.
- **USE GOOD COMMON SENSE.**
- If load appears to be unsafe, do not lift or lower it.

For a free copy of other manuals that pertain to this model Liftgate, please visit our website at [www.maxonlift.com](http://www.maxonlift.com) or call Customer Service at (800) 227-4116

P/N 282522-01 **C**

**SAFETY INSTRUCTIONS**

**Read all decals and operation manual before operating liftgate.**

1. Do not use liftgate unless you have been properly instructed and have read, and are familiar with, the operating instructions.
2. Be certain vehicle is properly and securely braked before using the liftgate.
3. Always inspect this liftgate for maintenance or damage before using it. Do not use liftgate if it shows any sign of damage or improper maintenance.
4. Do not overload
5. Make certain the area in which the platform will open and close is clear before opening or closing the platform.
6. Make certain platform area, including the area in which loads may fall from platform, is clear before and at all times during operation of liftgate.
7. This liftgate is intended for loading and unloading of cargo only. Do not use this liftgate for anything but its intended use.

P/N 282522-01 **A**

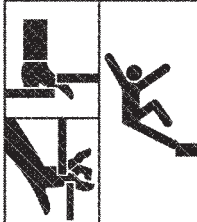

**WARNING**

**Liftgate hazards can result in crushing or falling.**

**Keep hands and feet clear of pinch points.**

**If riding liftgate, make sure load is stable and footing is solid.**

P/N 282522-01 **B**

**Read and understand all instructions and WARNINGS before use.**

**DECAL SHEET P/N 282522-01  
FIG. 25-1**

MODEL	DECAL P/N	CAPACITY
TE-15	220386	1500 POUNDS [680 KG]
TE-20	220387	2000 POUNDS [907 KG]
TE-25	220382	2500 POUNDS [1134 KG]
TE-30	220388	3000 POUNDS [1360 KG]

**CAPACITY DECALS  
TABLE 25-1**

# SYSTEM DIAGRAMS

## PUMP, MOTOR & SOLENOID OPERATION - GRAVITY DOWN

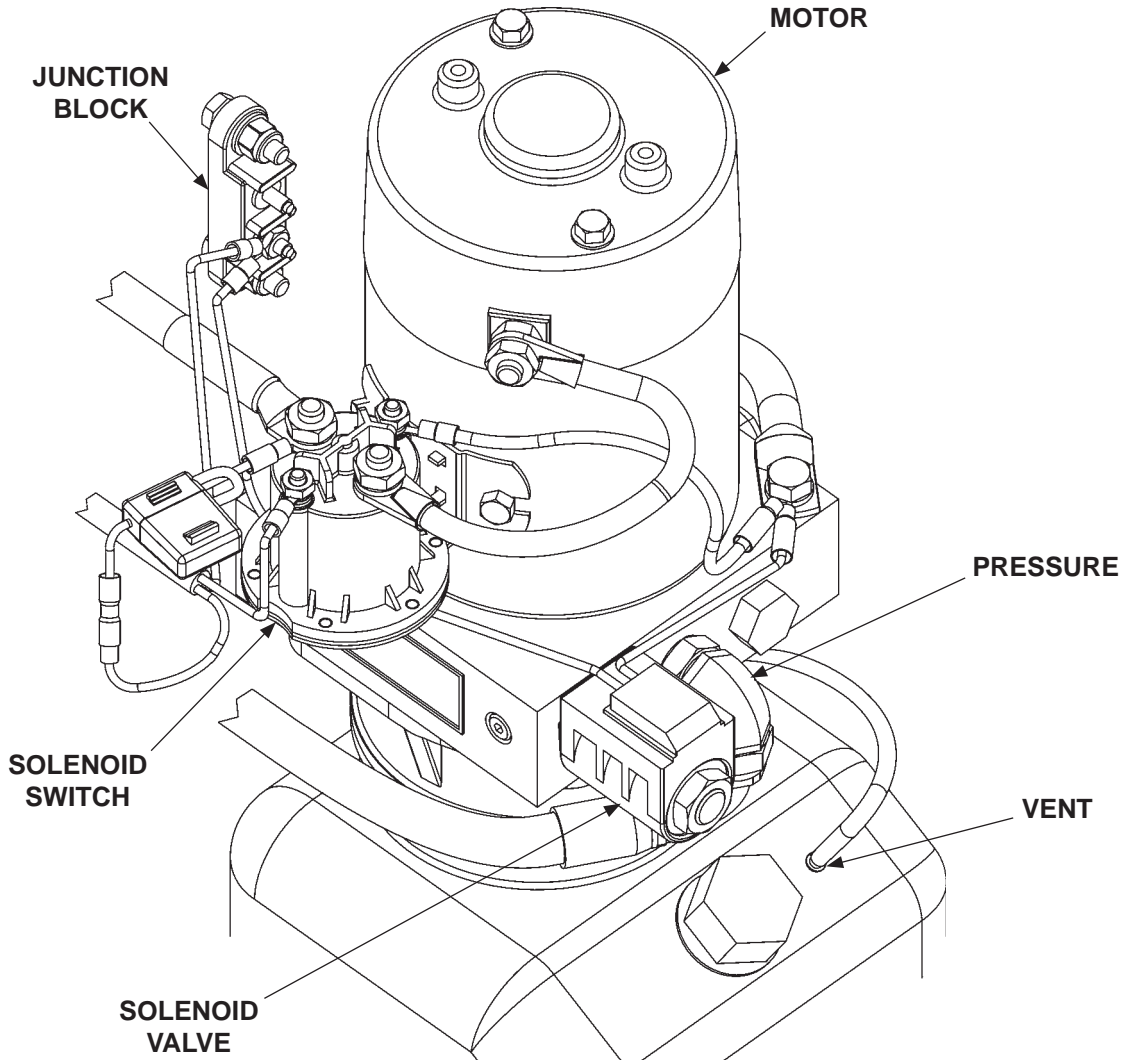

GRAVITY DOWN PUMP MOTOR & SOLENOID SWITCH OPERATION			
LIFTGATE FUNCTION	PORT	SOLENOID SWITCH OPERATION ✓ ( MEANS ENERGIZED)	
		MOTOR	SOLENOID VALVE
RAISE	PRESSURE	✓	-
LOWER	VENT	-	✓
REFER TO VALVES SHOWN ON HYDRAULIC SCHEMATIC			

**TABLE 26-1**

## PUMP, MOTOR & SOLENOID OPERATION - POWER DOWN

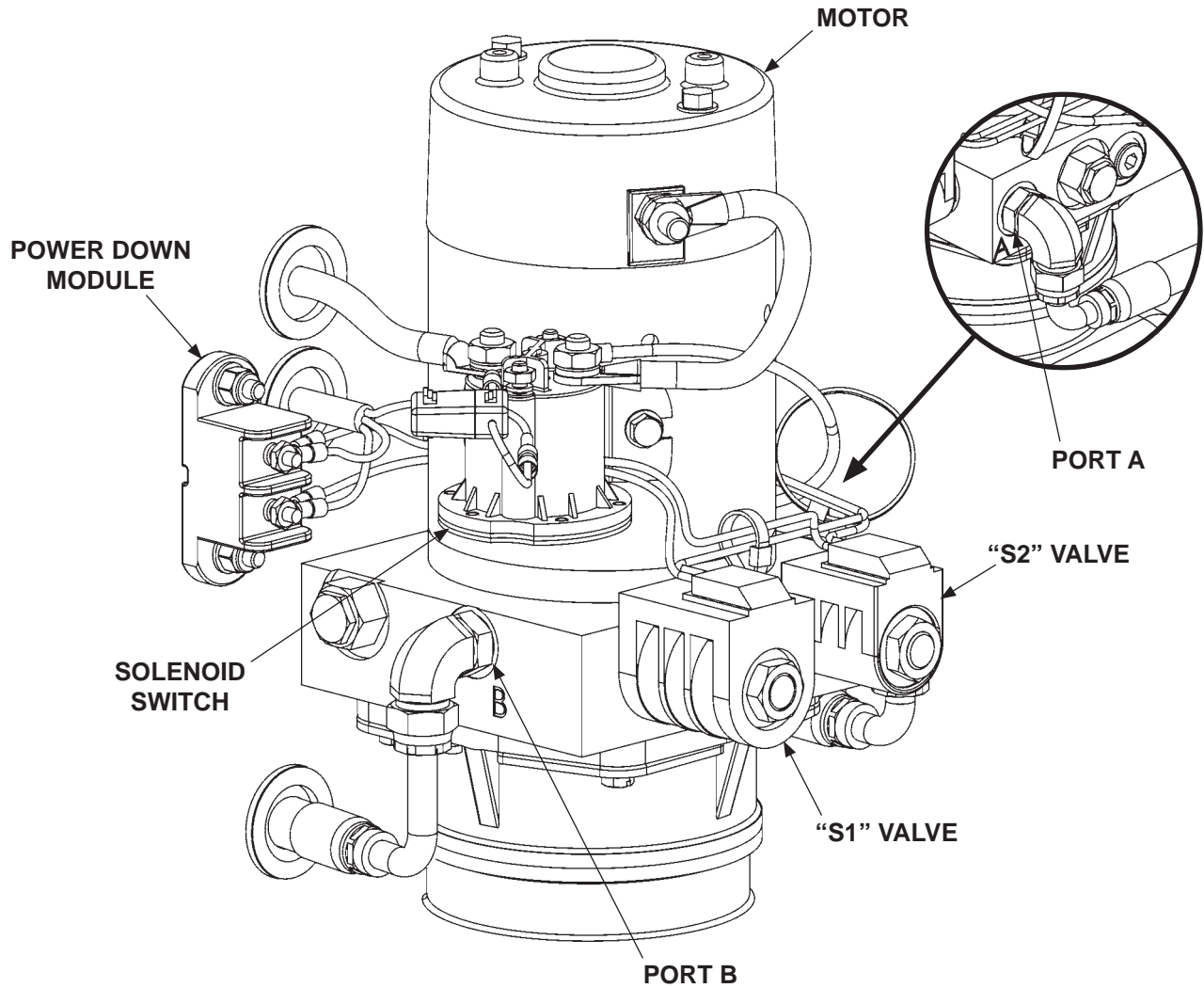

POWER DOWN PUMP MOTOR & SOLENOID SWITCH OPERATION					
LIFTGATE FUNCTION	PORT	SOLENOID SWITCH OPERATION (✓ MEANS ENERGIZED)			
		MOTOR	VALVE "S2"	VALVE "S1"	POWER DOWN MODULE
RAISE	A	✓	-	✓	-
LOWER	B	✓	✓	-	✓
REFER TO VALVES SHOWN ON HYDRAULIC SCHEMATIC					

**TABLE 27-1**

# HYDRAULIC SYSTEM DIAGRAMS

## HYDRAULIC SCHEMATIC (GRAVITY DOWN)

**MAXON**<sup>®</sup>

11921 Slauson Ave. Santa Fe Springs, CA. 90670 (800) 227-4116 FAX (888) 771-7713

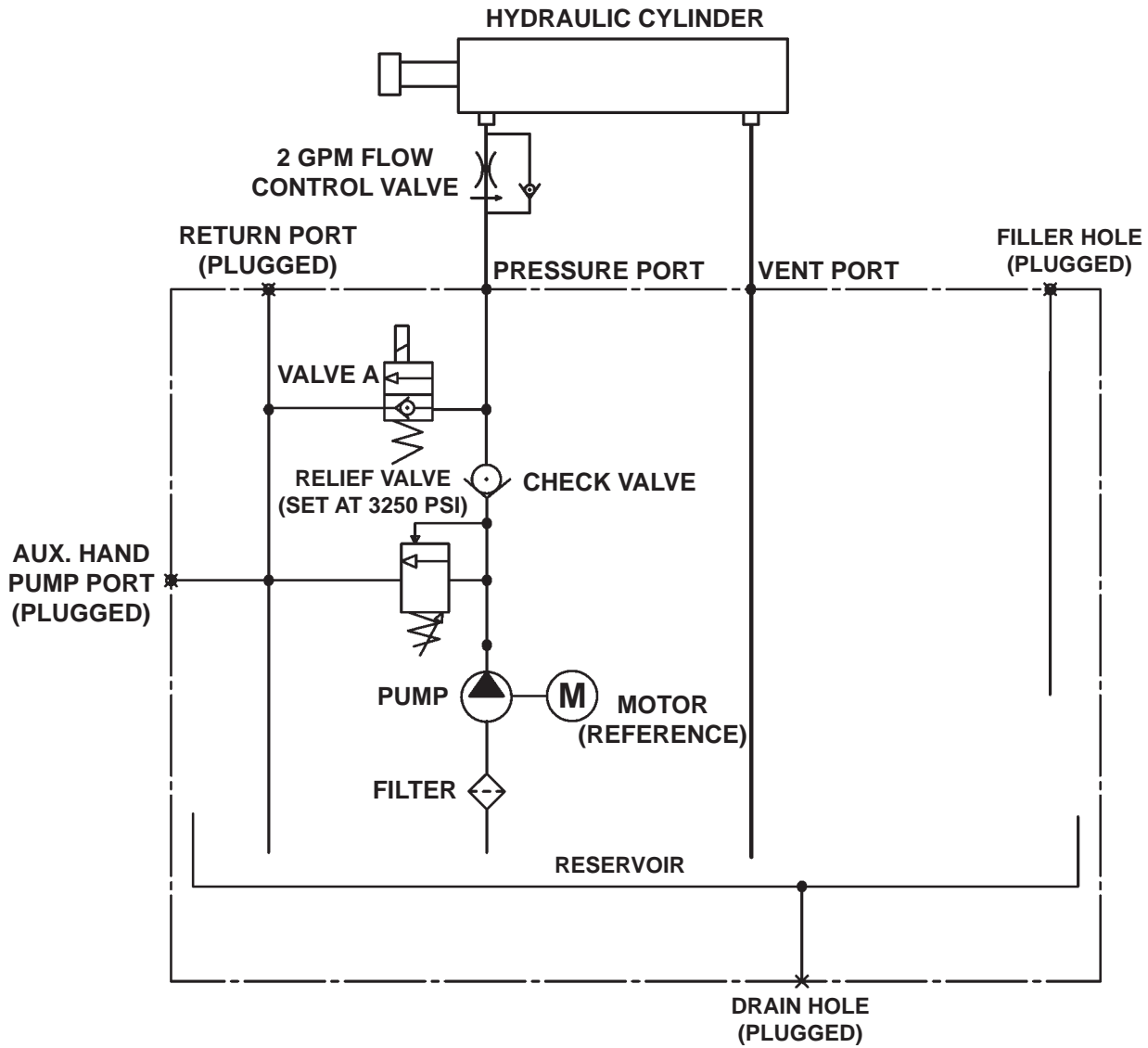

FIG. 28-1

# HYDRAULIC SCHEMATIC (POWER DOWN)

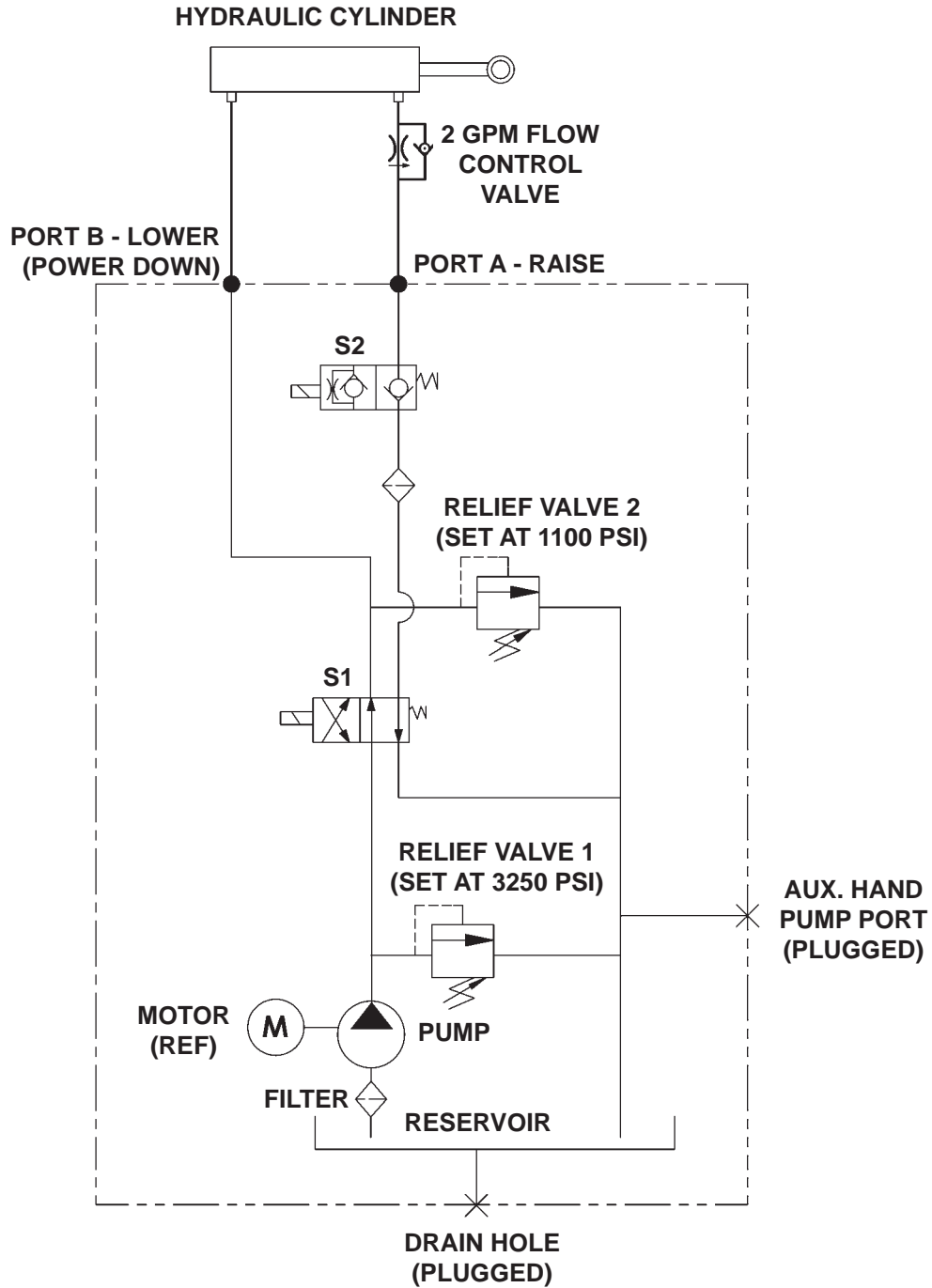

FIG. 29-1

# ELECTRICAL SYSTEM DIAGRAMS

## ELECTRICAL SCHEMATIC (GRAVITY DOWN)

**MAXON®**

11921 Slauson Ave. Santa Fe Springs, CA. 90670 (800) 227-4116 FAX (888) 771-7713

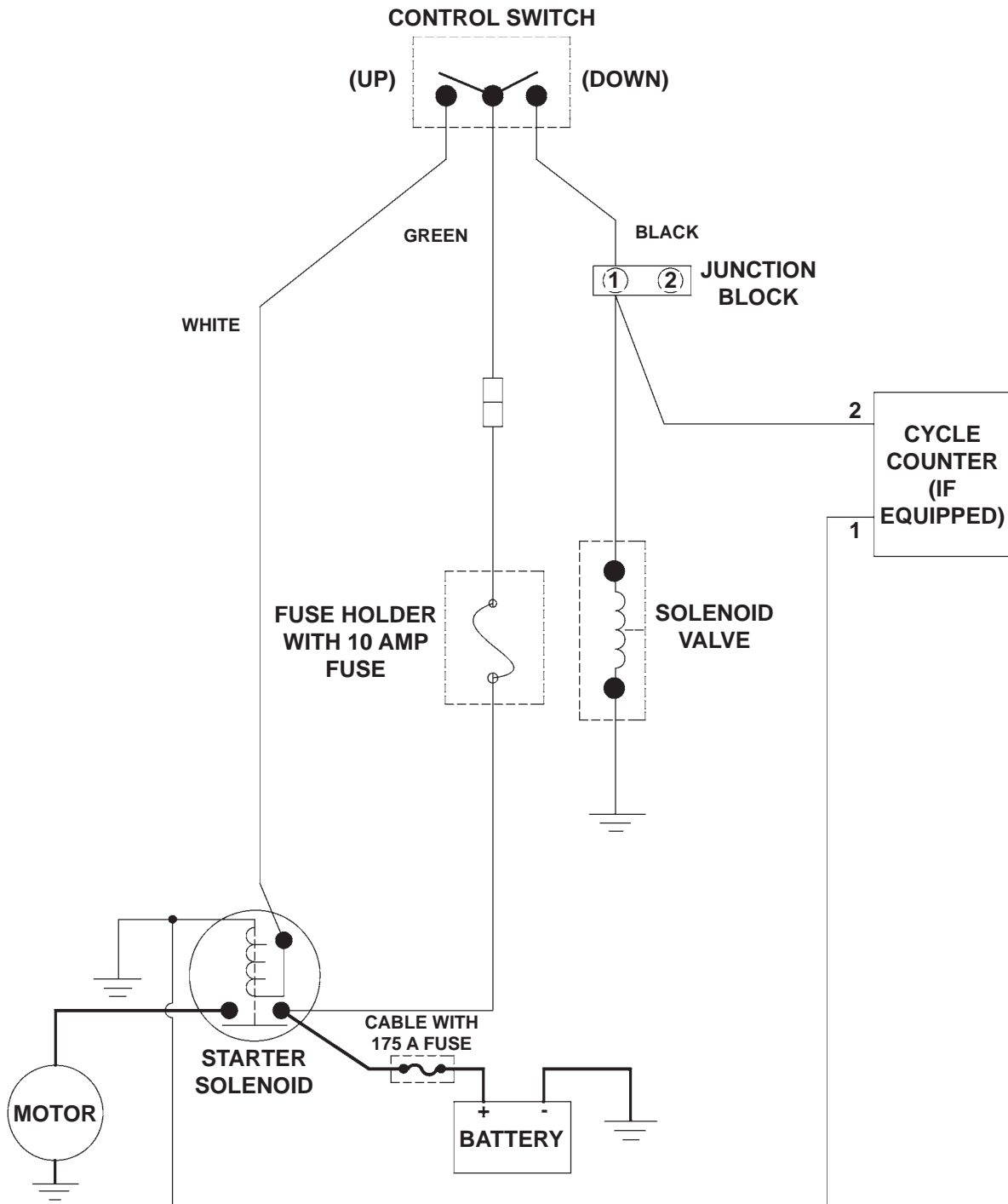

FIG. 30-1

# ELECTRICAL SCHEMATIC (POWER DOWN)

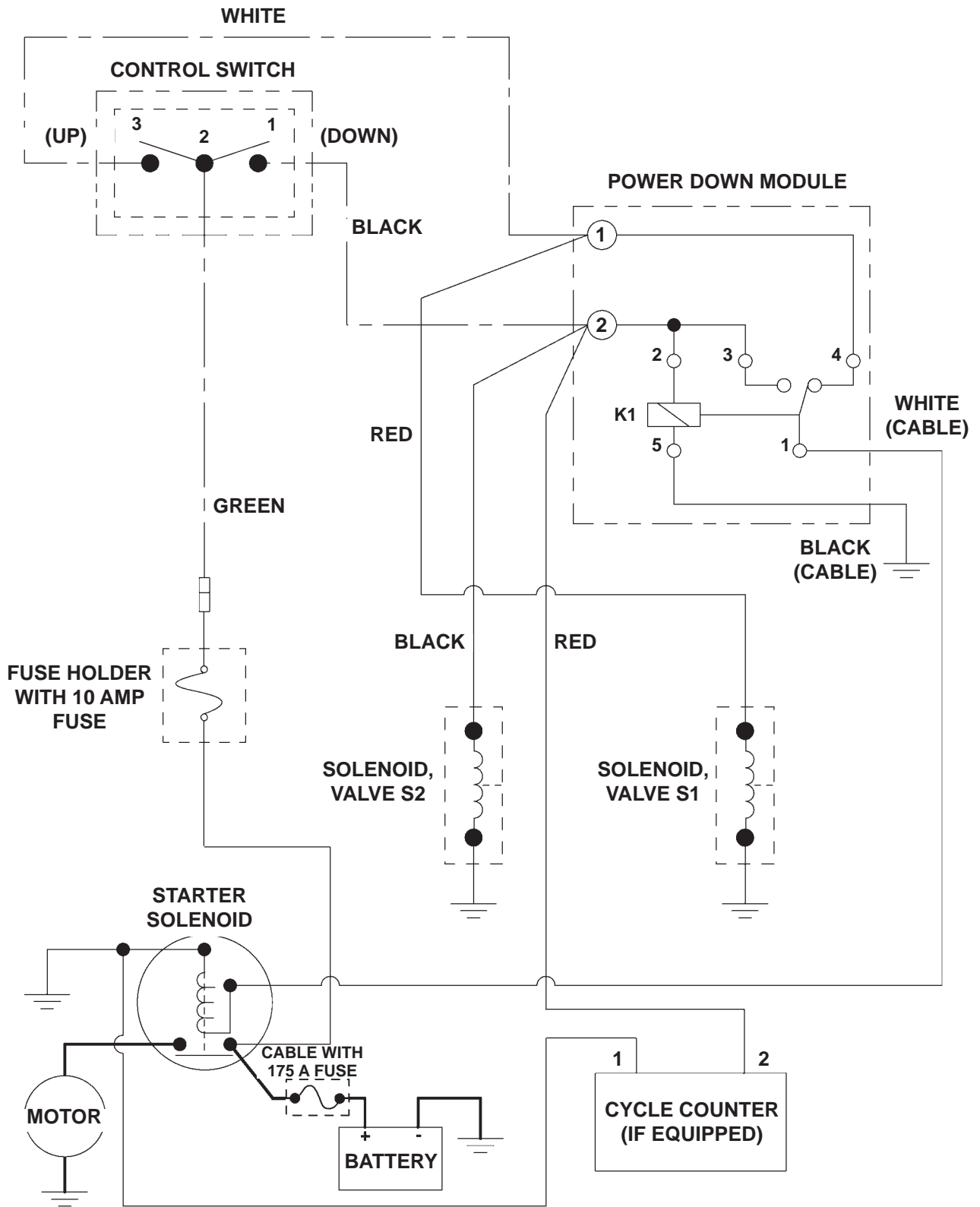

FIG. 31-1

## SYSTEM DIAGRAMS

### TE SERIES ELECTRICAL VALUES

Solenoid Switch	12V	24V
Coil Resistance:	5.4Ω @70°F. ±15%	20.1Ω @70°F. ±15%
Ampere:	2.2A	1.2A
Coil terminal torque: <b>10-15 lb-in</b> max.		
Contact terminal torque: <b>30-35 lb-in</b> max.		
<b>Solenoid Valves (A, S1, &amp; S2)</b>		
Coil Resistance:	6.6Ω @ 70°F. ±15%	26.7Ω @ 70°F. ±15%
Ampere:	1.8A	0.9A
Coil terminal torque: <b>15-45 lb-in</b> max.		
Valve cartridge torque: <b>25-30 lb-ft</b> max.		
Coil nut torque: <b>15-45 lb-in</b>		
<b>Solenoid Lock Valve</b>		
Coil Resistance:	8.0Ω @ 70°F. ±15%	30Ω @ 70°F. ±15%
Ampere:	1.5A	0.8A
Coil terminal torque: <b>3-4.5 lb-ft</b> max.		
Valve cartridge torque: <b>18.5-22 lb-ft</b> max.		
<b>Ground Cable</b>		
Cap Screw Torque: <b>24 lb-ft</b> max.		

TABLE 32-1

**MAXON**<sup>®</sup>

11921 Slauson Ave. Santa Fe Springs, CA. 90670 (800) 227-4116 FAX (888) 771-7713



# TROUBLESHOOTING PLATFORM WILL NOT RAISE

1. Use voltmeter to verify power is being supplied to solenoid terminal “B” (FIG. 33-1). Recharge the battery if there is less than 12.6 volts.

## CAUTION

Keep dirt, water and other contaminants from entering the hydraulic system. Before opening the hydraulic fluid reservoir filler cap, drain plug and hydraulic lines, clean up contaminants that can get in the openings. Also, protect the openings from accidental contamination during maintenance.

2. See the **CHECKING HYDRAULIC FLUID** procedure. If necessary, add hydraulic fluid.
3. Touch a jumper wire to terminals “B” & “D” (FIG. 33-1). If motor runs, check switch, switch connections, and white wire. Check and correct wiring connections or replace the switch.
4. Touch heavy jumper cables to terminals “A” & “B” (FIG. 33-1).
  - a. If motor runs, replace the motor solenoid.
  - b. If motor does not run, repair or replace the pump motor.

**NOTE:** In most cases, you can avoid having to manually bleed hydraulic system by correctly positioning Liftgate platform before disconnecting any lifting cylinder high pressure hydraulic lines. The following procedure can save time and prevent accidental fluid spills and hazards.

5. Check for structural damage and replace worn parts.
6. Check filter in the pump reservoir. Replace filter if necessary.
7. Check for dirty pump motor relief valve. Clean if necessary. Replace any worn out relief valve parts.

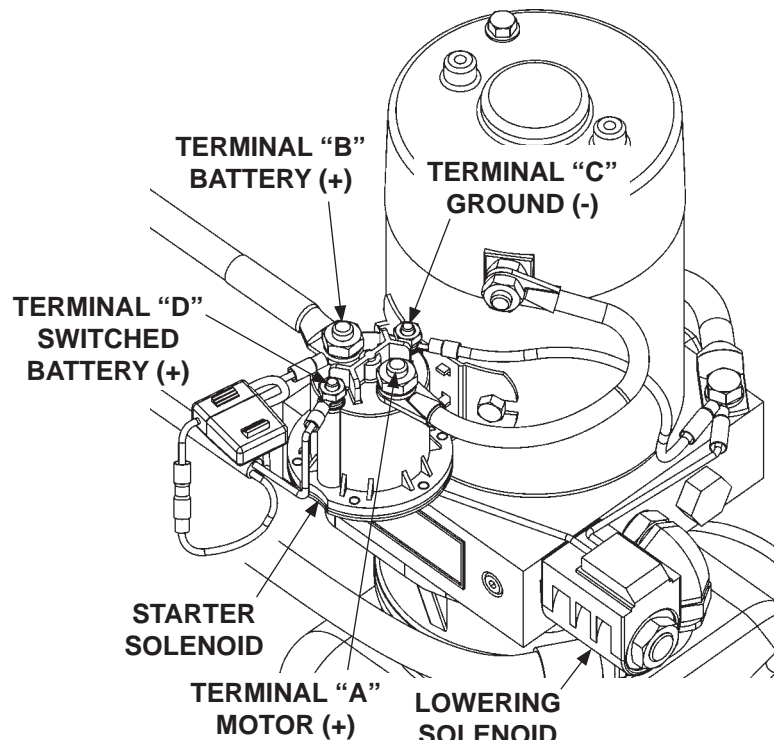
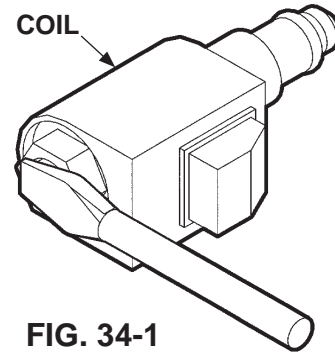

FIG. 33-1

# TROUBLESHOOTING PLATFORM RAISES BUT LEAKS DOWN

1. Check if solenoid valves are constantly energized by touching a screwdriver to the top nut of the solenoid (**FIG. 34-1**). Try pulling the screwdriver away from the solenoid. If the solenoid nut attracts the screwdriver (magnetically) without pushing the toggle switch, the control circuit is operating incorrectly. Check if toggle switch, wiring or coil are faulty.



**FIG. 34-1**

## CAUTION

Keep dirt, water and other contaminants from entering the hydraulic system. Before opening the hydraulic fluid reservoir filler cap, drain plug and hydraulic lines, clean up contaminants that can get in the openings. Also, protect the openings from accidental contamination during maintenance.

**NOTE:** In most cases, you can avoid having to manually bleed hydraulic system by correctly positioning Liftgate platform before disconnecting any lifting cylinder high pressure hydraulic lines. The following procedure can save time and prevent accidental fluid spills and hazards.

2. Check the valve stem by removing the coil assembly (**Item 1, FIG. 34-2**). With platform on ground, unscrew the valve stem (**Item 2, FIG. 34-2**) from the pump. Push on the plunger that is located inside the valve stem by inserting a small screwdriver blade in the end. If the plunger does not move freely, (approximately 1/8") replace the valve stem. **When reinstalling valve stem, torque hex nut to 30 in-lbs.**
3. Check the hydraulic cylinder. With the platform on the ground, remove the hydraulic line from the vent/down port of the cylinder (**FIG. 34-3**). Raise the platform even with the bed. Allow pump motor to run two seconds more while you watch for hydraulic fluid at the vent/down port. A few drops of hydraulic fluid escaping the vent/down port is normal; however, if it streams from the vent/down port, piston seals are worn. Replace seals.

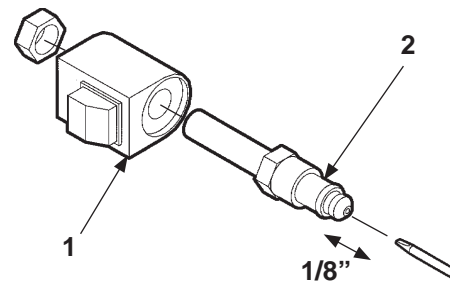

**FIG. 34-2**

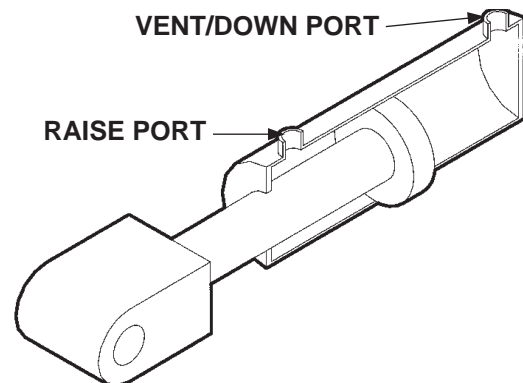

**FIG. 34-3**

## PLATFORM RAISES PARTIALLY AND STOPS

### CAUTION

Keep dirt, water and other contaminants from entering the hydraulic system. Before opening the hydraulic fluid reservoir filler cap, drain plug and hydraulic lines, clean up contaminants that can get in the openings. Also, protect the openings from accidental contamination during maintenance.

1. See the **CHECKING HYDRAULIC FLUID** procedure. If necessary, add hydraulic fluid.
2. Use voltmeter to verify the battery shows 12.6 volts or more.
3. Check for structural damage and poor lubrication. Replace worn parts.

**NOTE:** In most cases, you can avoid having to bleed the hydraulic system by correctly positioning Liftgate platform before opening hydraulic lines. Refer to following procedure. Save time on the job and prevent accidental fluid spills and hazards.

4. Check the hydraulic cylinder. With the platform on the ground, remove the breather plug or vent line from the vent/down port of the cylinder (**FIG. 35-1**). Raise the platform even with the bed. Allow pump motor to run two seconds more while you watch for hydraulic fluid at the vent/down port. A few drops of hydraulic fluid escaping the vent/down port is normal; however, if it streams from the vent/down port, piston seals are worn. Replace seals.
5. Check filter in the pump reservoir. Replace filter if necessary.
6. Check for dirty pump motor relief valve. Clean if necessary. Replace any worn out relief valve parts.

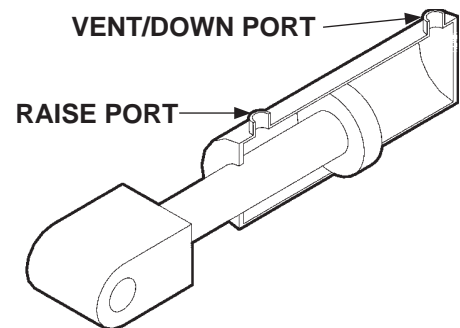

**FIG. 35-1**

# TROUBLESHOOTING

## LIFTGATE WILL NOT LIFT RATED CAPACITY

1. Use voltmeter to verify the battery shows 12.6 volts or more under load from pump motor.
2. Check for structural damage and lack of lubrication. Replace worn parts.

### CAUTION

Keep dirt, water and other contaminants from entering the hydraulic system. Before opening the hydraulic fluid reservoir filler cap, drain plug and hydraulic lines, clean up contaminants that can get in the openings. Also, protect the openings from accidental contamination during maintenance.

**NOTE:** In most cases, you can avoid having to bleed the hydraulic system by correctly positioning Liftgate platform before opening hydraulic lines. Refer to following procedure. Save time on the job and prevent accidental fluid spills and hazards.

3. With platform on the ground, remove the pressure hose and fitting from the pump and replace it with a 0-4000 PSI pressure gauge. Hold the switch in the "UP" position. Adjust the relief valve on the side of the pump until the gauge shows 3250 PSI (**FIG. 36-2**). Remove gauge and reinstall pressure hose.
4. Check for dirty pump motor relief valve. Clean if necessary. Replace any worn out relief valve parts.
5. Check the hydraulic cylinder. With the platform on the ground, remove the breather plug or vent line from the vent/down port of the cylinder (**FIG. 36-1**). Raise the platform even with the bed. Allow pump motor to run two seconds more while you watch for hydraulic fluid at the vent/down port. A few drops of hydraulic fluid escaping the vent/down port is normal; however, if it streams from the vent/down port, piston seals are worn. Replace seals.
6. If pump cannot produce 3250 PSI, and will not lift load of rated capacity, the pump is worn and needs to be replaced.

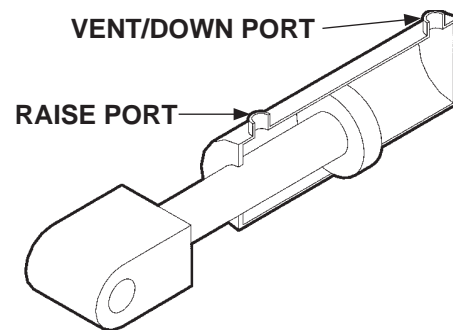

FIG. 36-1

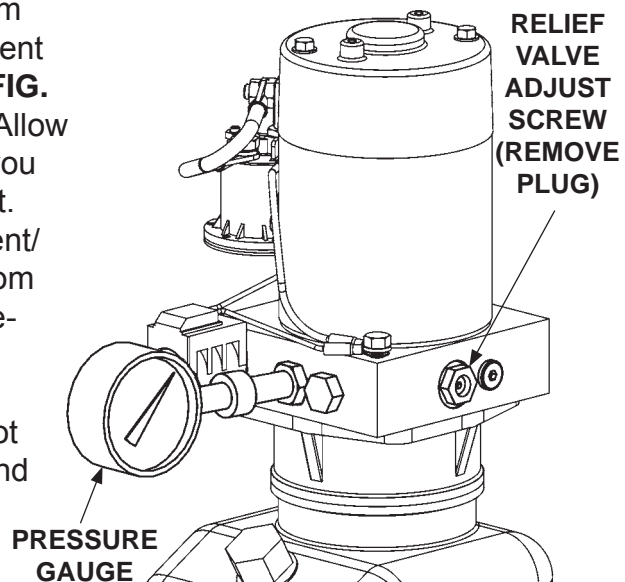
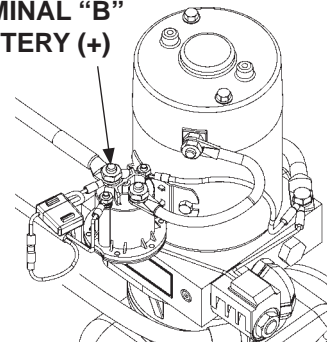

FIG. 36-2

## PLATFORM RAISES SLOWLY

1. Use voltmeter to verify power is being supplied to solenoid terminal "B". Recharge the battery if voltmeter indicates less than 12.6 volts (**FIG. 37-1**).

TERMINAL "B"  
BATTERY (+)



**FIG. 37-1**

### CAUTION

Keep dirt, water and other contaminants from entering the hydraulic system. Before opening the hydraulic fluid reservoir filler cap, drain plug and hydraulic lines, clean up contaminants that can get in the openings. Also, protect the openings from accidental contamination during maintenance.

2. Check the hydraulic cylinder. With the platform on the ground, remove the breather plug or vent line from the vent/down port of the cylinder (**FIG. 37-3**). Raise the platform even with the bed. Allow pump motor to run two seconds more while you watch for hydraulic fluid at the vent/down port. A few drops of hydraulic fluid escaping the vent/down port is normal; however, if it streams from the vent/down port, piston seals are worn. Replace seals.

**NOTE:** In most cases, you can avoid having to bleed the hydraulic system by correctly positioning Liftgate platform before opening hydraulic lines. Refer to following procedure. Save time on the job and prevent accidental fluid spills and hazards.

3. Check and clean flow control valve in high pressure hydraulic line attached to cylinder. When installing flow control valve, make sure arrow on valve is oriented as shown in **FIG. 37-3**.
4. See the **CHECKING HYDRAULIC FLUID** procedure. If necessary, add hydraulic fluid.

5. Verify the pump motor is grounded to the vehicle frame.
6. Check for leaking hoses and fittings. Tighten or replace as required.

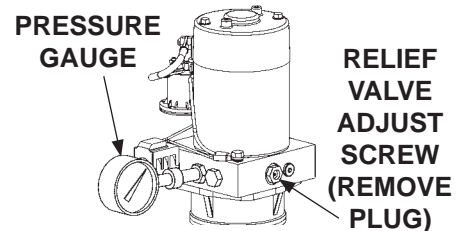
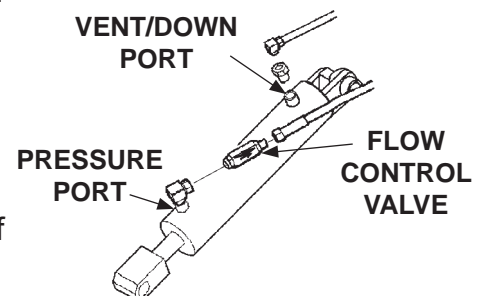

**FIG. 37-2**

7. Check for structural damage or poor lubrication. Replace worn parts.

8. Check the filter in the pump reservoir. Replace if necessary.

9. With platform on the ground, remove the pressure hose and fitting from the pump and replace it with a 0-4000 PSI pressure gauge. Hold the control switch in the "raise" position. Adjust the relief valve on the side of the pump until the gauge shows 3250 PSI (**FIG. 37-2**). Remove gauge and reinstall pressure hose.

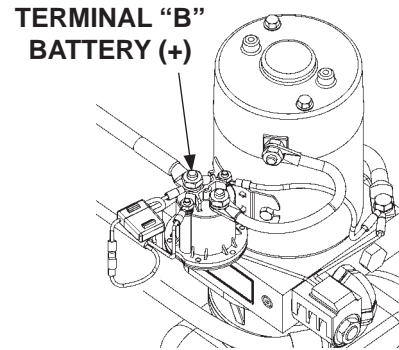

**FIG. 37-3**

# TROUBLESHOOTING

## PLATFORM WILL NOT LOWER, LOWERS TOO SLOWLY OR TOO QUICKLY

1. Use voltmeter to verify power is being supplied to solenoid terminal "B". Recharge the battery if voltmeter displays less than 12.6 volts (**FIG. 38-1**).
2. Check for structural damage or poor lubrication. Replace worn parts.
3. Check if solenoid valve is getting power by holding a screwdriver against the top nut of the solenoid. Push control switch to "lower" position to energize solenoid (**FIG. 38-2**). A good solenoid will attract (magnetically) the screwdriver to the nut and make it difficult to pull the screwdriver away from the nut.



**FIG. 38-1**

### CAUTION

Keep dirt, water and other contaminants from entering the hydraulic system. Before opening the hydraulic fluid reservoir filler cap, drain plug and hydraulic lines, clean up contaminants that can get in the openings. Also, protect the openings from accidental contamination during maintenance.

**NOTE:** In most cases, you can avoid having to bleed the hydraulic system by correctly positioning Liftgate platform before opening hydraulic lines. Refer to following procedure. Save time on the job and prevent accidental fluid spills and hazards.

4. Check the valve stem by removing the coil assembly (**Item 1, FIG. 38-2**). With platform supported, unscrew the valve stem (**Item 2, FIG. 38-2**) from the pump. Push on the plunger located inside the valve stem by inserting a small screwdriver blade in the end. If the plunger does not move freely (approximately 1/8"), replace the valve stem.
5. Check if filtering screen on solenoid valve is plugged. Clean carefully if required.
6. Check and clean flow control valve in high pressure hydraulic line attached to cylinder.
7. Check if flow control valve (**FIG. 38-3**) is pointing to the direction of restricted fluid flow (back toward pump). If required, remove flow control valve and install it correctly (**FIG. 38-3**).

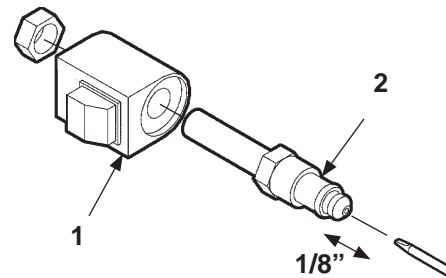

**FIG. 38-2**

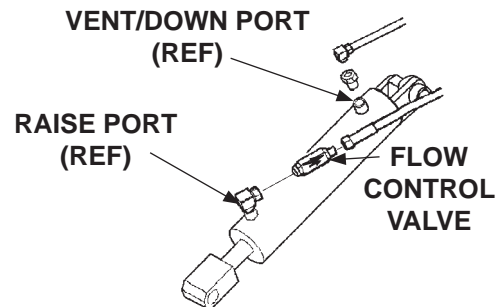

**FIG. 38-3**

