

MAXON[®]

GPT Series

M-17-08
OCTOBER 2017

MAINTENANCE MANUAL

GPT-25, GPT-3, GPT-4, & GPT-5

GPTWR-25, GPTWR-3, GPTWR-4, & GPTWR-5

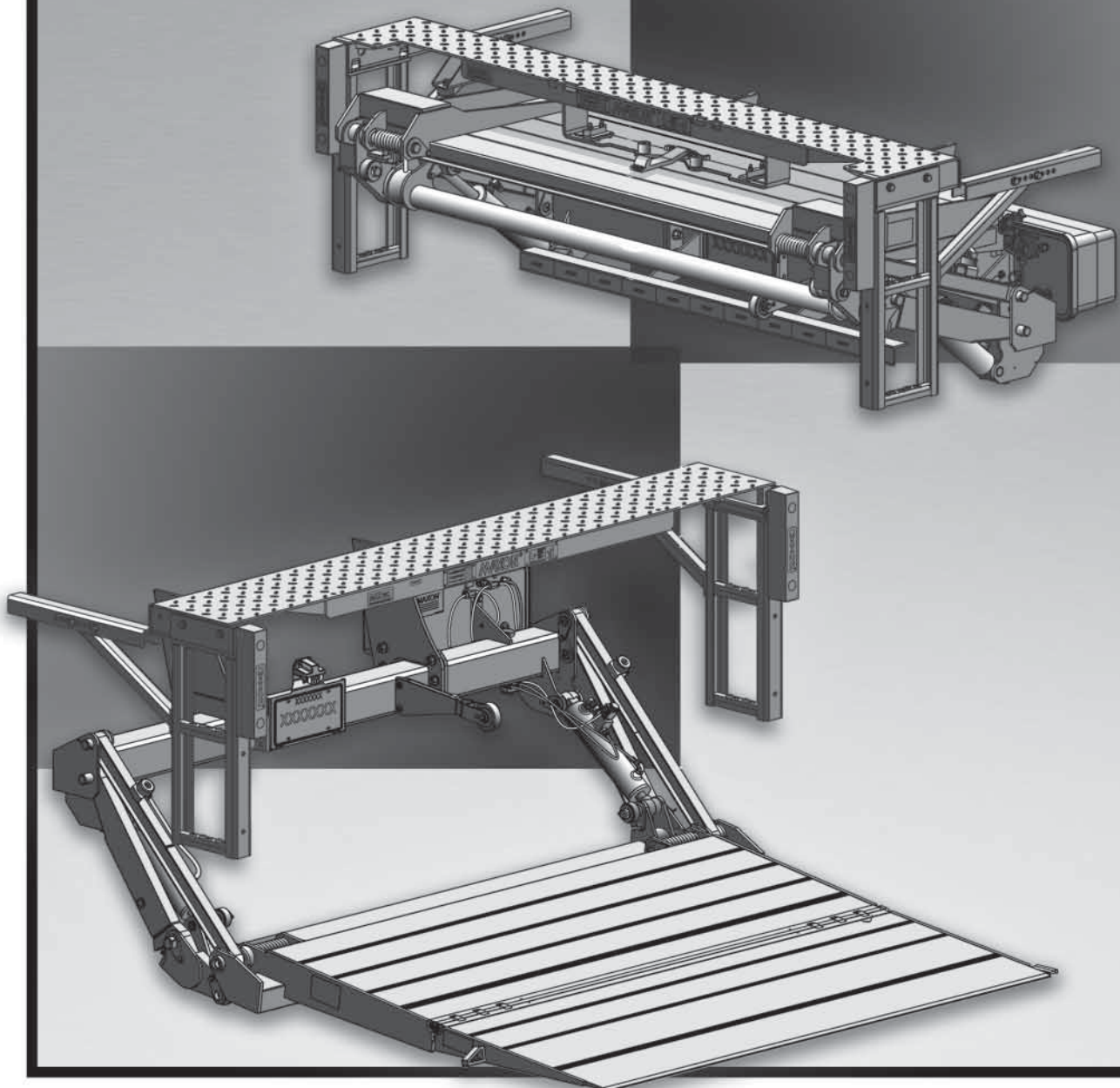

MAXON[®]

LIFT CORP.

11921 Slauson Ave.
Santa Fe Springs, CA. 90670

CUSTOMER SERVICE:

TELEPHONE (562) 464-0099 TOLL FREE (800) 227-4116

FAX: (888) 771-7713

NOTE: For latest version of all Manuals (and replacements), download the Manuals from Maxon's website at www.maxonlift.com.

WARRANTY/ RMA POLICY & PROCEDURE

LIFTGATE WARRANTY

Type of Warranty: Full Parts and Labor

Term of Warranty: Standard Liftgates - 2 years from ship date or 6,000 cycles
Premium Liftgates - 2 years from ship date or 10,000 cycles

This warranty shall not apply unless the product is installed, operated and maintained in accordance with MAXON Lift's specifications as set forth in MAXON Lift's Installation, Operation and Maintenance manuals. This warranty does not cover normal wear, maintenance or adjustments, damage or malfunction caused by improper handling, installation, abuse, misuse, negligence, or carelessness of operation. In addition, this warranty does not cover equipment that has had unauthorized modifications or alterations made to the product.

MAXON agrees to replace any components which are found to be defective during the first 2 years of service, and will reimburse for labor based on MAXON's Liftgate Warranty Flat Rate Schedule. (Copy of the Flat Rate is available at www.maxonlift.com.)

All warranty repairs must be performed by an authorized MAXON warranty facility. For any repairs that may exceed \$500, including parts and labor, MAXON's Technical Service Department must be notified and an "Authorization Number" obtained.

All claims for warranty must be received within 30 Days of the repair date, and include the following information:

1. Liftgate Model Number and Serial Number
2. The End User must be referenced on the claim
3. Detailed Description of Problem
4. Corrective Action Taken, and Date of Repair
5. Parts used for Repair, Including MAXON Part Number(s)
6. MAXON R.M.A. # and/or Authorization # if applicable (see below)
7. Person contacted at MAXON if applicable
8. Claim must show detailed information i.e. Labor rate and hours of work performed

Warranty claims can also be placed online at www.maxonlift.com. Online claims will be given priority processing.

All claims for warranty will be denied if paperwork has not been received or claim submitted via Maxon website for processing by MAXON's Warranty Department within 30 days of repair date.

All components may be subject to return for inspection, prior to the claim being processed. MAXON products may not be returned without prior written approval from MAXON's Technical Service Department. Returns must be accompanied by a copy of the original invoice or reference with original invoice number and are subject to a credit deduction to cover handling charges and any necessary reconditioning costs. **Unauthorized returns will be refused and will become the responsibility of the returnee.**

Any goods being returned to MAXON Lift must be pre-approved for return, and have the R.M.A. number written on the outside of the package in plain view, and returned freight prepaid. All returns are subject to a 15% handling charge if not accompanied by a detailed packing list. Returned parts are subject to no credit and returned back to the customer. Defective parts requested for return must be returned within 30 days of the claim date for consideration to:

MAXON Lift Corp.
10321 Greenleaf Ave., Santa Fe Springs, CA 90670
Attn: RMA# _____

MAXON's warranty policy does not include the reimbursement for travel time, towing, vehicle rental, service calls, oil, batteries or loss of income due to downtime. Fabrication or use of non Maxon parts, which are available from MAXON, are also not covered.

MAXON's Flat Rate Labor Schedule takes into consideration the time required for diagnosis of a problem.

All Liftgates returned are subject to inspection and a 15% restocking fee. Any returned Liftgates or components that have been installed or not returned in new condition will be subject to an additional reworking charge, which will be based upon the labor and material cost required to return the Liftgate or component to new condition.

PURCHASE PART WARRANTY

Term of Warranty: 1 Year from Date of Purchase.

Type of Warranty: Part replacement only. MAXON will guarantee all returned genuine MAXON replacement parts upon receipt and inspection of parts and original invoice.

All warranty replacements parts will be sent out via ground freight. If a rush shipment is requested, all freight charges will be billed to the requesting party.

TABLE OF CONTENTS

WARNINGS	6
SAFETY INSTRUCTIONS	7
LIFTGATE TERMINOLOGY	8
PERIODIC MAINTENANCE	9
PERIODIC MAINTENANCE CHECKS.....	9
PERIODIC MAINTENANCE CHECKLIST.....	10
CHECKING HYDRAULIC FLUID	12
CHANGING HYDRAULIC FLUID.....	14
REPLACING PLATFORM TORSION SPRING	16
PLATFORM ADJUSTMENT	17
DECALS (GPT)	19
DECALS (GPTWR)	21
SYSTEM DIAGRAMS	23
PUMP, MOTOR & SOLENOID OPERATION	23
HYDRAULIC SCHEMATIC (POWER DOWN)	24
ELECTRICAL SCHEMATIC (POWER DOWN).....	25
GPT/GPTWR ELECTRICAL VALUES.....	26
TROUBLESHOOTING	28
PLATFORM WILL NOT RAISE & MOTOR WILL NOT RUN	28
PLATFORM WILL NOT RAISE, BUT MOTOR RUNS.....	29
PLATFORM RAISES BUT LEAKS DOWN.....	30
PLATFORM RAISES PARTIALLY AND STOPS.....	32
LIFTGATE WILL NOT LIFT RATED CAPACITY.....	33
PLATFORM RAISES SLOWLY	34
PLATFORM WILL NOT LOWER, LOWERS TOO SLOWLY OR TOO QUICKLY.....	36

PLATFORM BEGINS TO LOWER ON LH SIDE, BUT WILL NOT LOWER ON RH SIDE .. 38
PLATFORM WILL NOT TILT DOWN TO THE GROUND 41

Comply with the following **WARNINGS** and **SAFETY INSTRUCTIONS** while maintaining Liftgates. See Operation Manual for operating safety requirements.

⚠ WARNING

- Do not stand, or allow obstructions, under the platform when lowering the Liftgate. **Be sure your feet are clear of the Liftgate.**
- **Keep fingers, hands, arms, legs, and feet clear of moving Liftgate parts (and platform edges) when operating the Liftgate.**
- **Correctly stow platform when not in use. Extended platforms could create a hazard for people and vehicles passing by.**
- **Disconnect Liftgate power cable from battery** before repairing or servicing Liftgate.
- If it is necessary to stand on the platform while maintaining the Liftgate, keep your feet and any objects clear of the inboard edge of the platform. Your feet or objects on the platform can become trapped between the platform and the Liftgate extension plate.
- Recommended practices for welding on steel parts are contained in the current **AWS (American Welding Society) D1.1 Structural Welding Code - Steel**. Damage to Liftgate and/or vehicle, and personal injury could result from welds that are done incorrectly.
- Recommended practices for welding on aluminum parts are contained in the current **AWS (American Welding Society) D1.2 Structural Welding Code - Aluminum**. Damage to Liftgate and/or vehicle, and personal injury could result from welds that are done incorrectly.
- Recommended practices for welding galvanized steel are contained in the current **AWS (American Welding Society) D19.0 Welding Zinc-Coated Steel**. Damage to Liftgate and/or vehicle, and personal injury can result from welds that are done incorrectly.

MAXON[®]

11921 Slauson Ave. Santa Fe Springs, CA. 90670 (800) 227-4116 FAX (888) 771-7713

SAFETY INSTRUCTIONS

- Read and understand the instructions in this **Maintenance Manual** before performing maintenance on the Liftgate.
- Before operating the Liftgate, read and understand the operating instructions in **Operation Manual**.
- Comply with all **WARNING** and instruction decals attached to the Liftgate.
- Keep decals clean and legible. If decals are illegible or missing, replace them. Free replacement decals are available from **Maxon Customer Service**.
- Consider the safety and location of bystanders and location of nearby objects when operating the Liftgate. Stand to one side of the platform while operating the Liftgate.
- Do not allow untrained persons to operate the Liftgate.
- Wear appropriate safety equipment such as protective eyeglasses, faceshield and clothing while performing maintenance on the Liftgate and handling the battery. Debris from drilling and contact with battery acid may injure unprotected eyes and skin.
- Be careful working by an automotive type battery. Make sure the work area is well ventilated and there are no flames or sparks near the battery. Never lay objects on the battery that can short the terminals together. If battery acid gets in your eyes, immediately seek first aid. If acid gets on your skin, immediately wash it off with soap and water.
- If an emergency situation arises (vehicle or Liftgate) while operating the Liftgate, release the control switch to stop the Liftgate.
- A correctly installed Liftgate operates smoothly and reasonably quiet. The only noticeable noise during operation comes from the power unit while the platform is raised. Listen for scraping, grating and binding noises and correct the problem before continuing to operate Liftgate.
- Use only **Maxon Authorized Parts** for replacement parts. Provide Liftgate model and serial number information with your parts order. Order replacement parts from:

MAXON LIFT CORP. Customer Service
11921 Slauson Ave., Santa Fe Springs, CA 90670

Online: www.maxonlift.com

Express Parts Ordering: Phone (800) 227-4116 ext. 4345

Email: Ask your Customer Service representative

LIFTGATE TERMINOLOGY

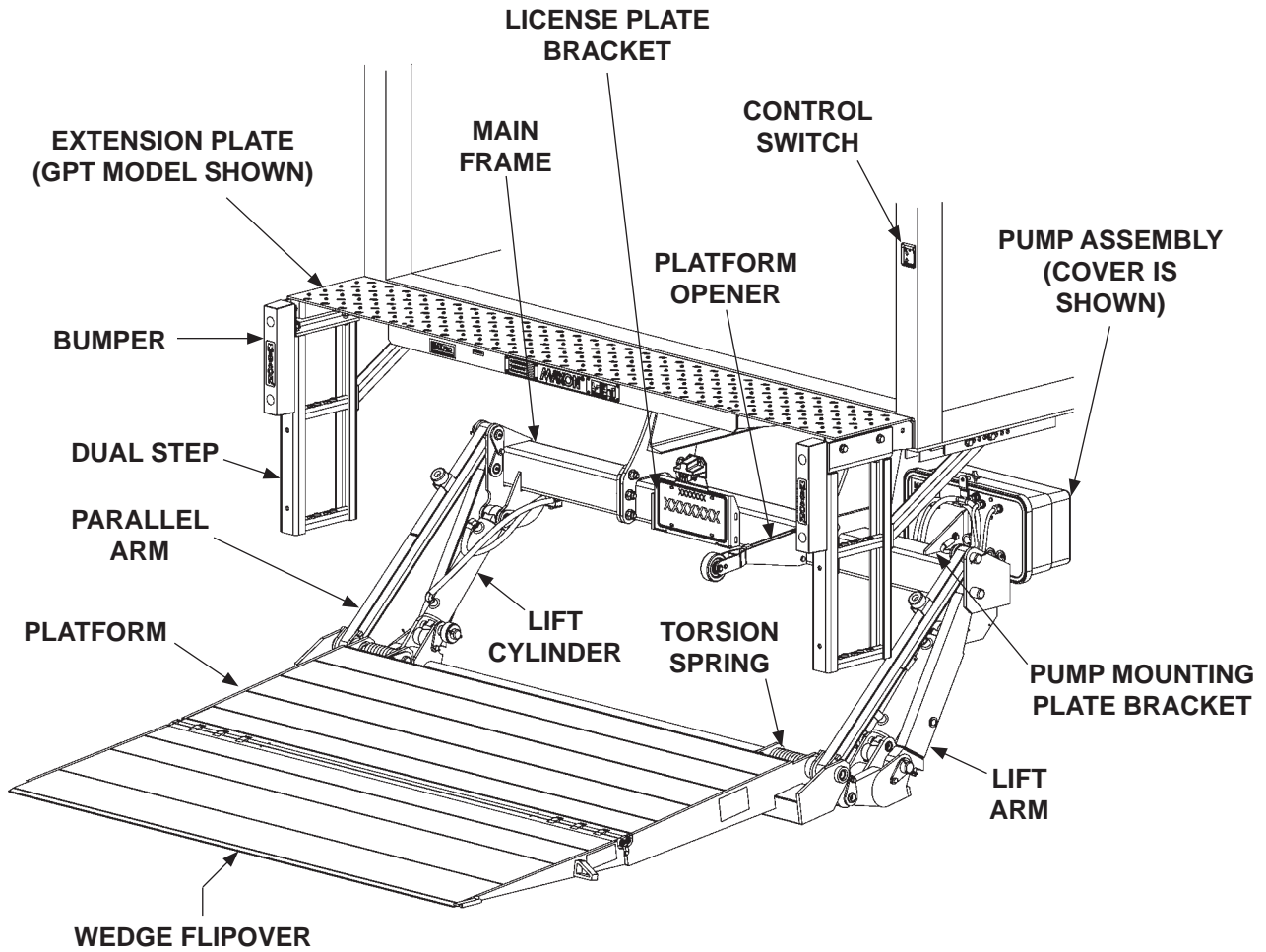

MAXON[®]

11921 Slauson Ave. Santa Fe Springs, CA. 90670 (800) 227-4116 FAX (888) 771-7713

PERIODIC MAINTENANCE PERIODIC MAINTENANCE CHECKS

⚠ WARNING

Never operate the Liftgate if parts are loose or missing.

NOTE: Make sure vehicle is parked on level ground while performing the maintenance checks.

Quarterly or 1250 Cycles (whichever occurs first)

Check the hydraulic fluid level in the pump reservoir. Refer to the **CHECKING HYDRAULIC FLUID** procedure in the **PERIODIC MAINTENANCE** section.

If hydraulic fluid appears contaminated, refer to the **CHANGING HYDRAULIC FLUID** procedure in the **PERIODIC MAINTENANCE** section.

Keep track of the grade of hydraulic fluid in the pump reservoir and never mix two different grades of fluid.

Check all hoses and fittings for chafing and fluid leaks. Tighten loose fittings or replace parts as required.

Check electrical wiring for chafing and make sure wiring connections are tight and free of corrosion. Use dielectric grease to protect electrical connections.

Check that all **WARNING and instruction decals** are in place. Also, make sure decals are legible, clean and undamaged.

Check that all bolts, nuts, and roll pins are in place. Make sure roll pins protrude evenly from both sides of hinge pin collar. Replace fasteners and roll pins if necessary.

Pump EP chassis grease in each lube fitting on the cylinders and arms until grease starts oozing from ends of the bearings. The lubrication diagram on the **PERIODIC MAINTENANCE CHECKLIST SHEET** shows where to find the lube fittings. Wipe off excess grease with a clean lint-free cloth.

CAUTION

Damaged cylinder seals and contaminated hydraulic fluid can result from painting the polished portion of the cylinder rod. To prevent damage, protect the exposed polished portion of the cylinder rod while painting.

Check for rust and oily surfaces on Liftgate. If there is rust or oil on Liftgate, clean it off. If bare metal is exposed on galvanized portions of the Liftgate, touch up the galvanized finish. To maintain original galvanized finish, MAXON recommends cold galvanize spray.

Semi-annually or 2500 Cycles (whichever occurs first)

Visually check the platform hinge pins for excessive wear and broken welds. See **PARTS BREAKDOWN** section for replacement parts. Also, do the **Quarterly or 1250 Cycles** maintenance checks.

PERIODIC MAINTENANCE CHECKLIST

NOTE: Make sure vehicle is parked on level ground while performing maintenance checks.

Quarterly or 1250 Cycles (whichever occurs first)

- Check the level and condition of the hydraulic fluid.
- Visually check all hoses and fittings for chafing and fluid leaks. Tighten loose fittings or replace parts as required.
- Check electrical wiring for chafing and make sure wiring connections are tight and free of corrosion. Use dielectric grease to protect electrical connections.
- Check that all **WARNING and instruction decals** are in place. Also, make sure decals are legible, clean, and undamaged.
- Check that all bolts, nuts, and roll pins are in place. Make sure roll pins protrude evenly from both sides of hinge pin collar. Replace fasteners and roll pins if necessary.
- Check for rust and oily surfaces on Liftgate. If there is rust or oil on Liftgate or if the Liftgate is dirty, clean it off. Touch up the galvanized finish where bare metal is showing.
- Pump EP chassis grease in each lube fitting on the cylinders and arms until grease starts oozing from ends of the bearings. Refer to lubrication diagram on the next page. Wipe off excess grease with a clean lint-free cloth.

Semi-annually or 2500 Cycles (whichever occurs first)

- Visually check the platform hinge pins for excessive wear and broken welds.
- Do the **Quarterly or 1250 Cycles Checks** on this checklist.

MAXON[®]

11921 Slauson Ave. Santa Fe Springs, CA. 90670 (800) 227-4116 FAX (888) 771-7713

PERIODIC MAINTENANCE CHECKLIST

NOTE: Lube fittings are shown for the RH cylinder, lift arm, and parallel arm. There are also lube fittings at the same places on the LH cylinder, lift arm, and parallel arm.

Refer to lubrication diagram (**FIG. 11-1**) to find the lube fittings on cylinders and arms. Pump EP chassis grease in each lube fitting on the cylinders and arms until grease starts oozing from ends of the bearings. Then, wipe off excess grease with a clean lint-free cloth.

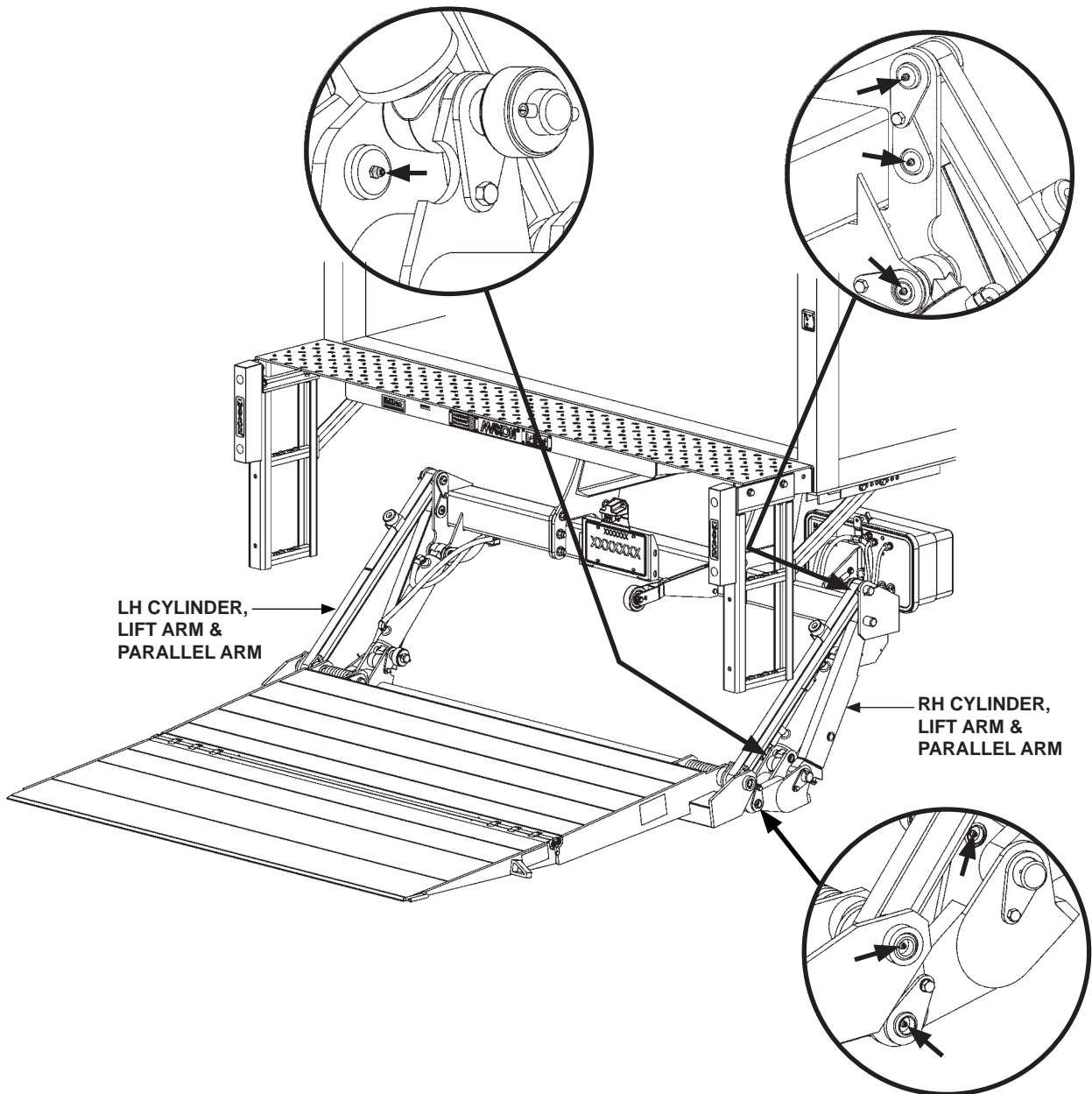

**GPT LUBRICATION DIAGRAM
FIG. 11-1**

PERIODIC MAINTENANCE

CHECKING HYDRAULIC FLUID

CAUTION

Keep dirt, water and other contaminants from entering the hydraulic system. Before opening the hydraulic fluid reservoir filler cap, drain plug and hydraulic lines, clean up contaminants that can get in the openings. Also, protect the openings from accidental contamination.

NOTE: Use correct grade of hydraulic fluid for your location.

+50 to +120 Degrees F - Grade ISO 32

Below + 70 Degrees F - Grade ISO 15 or MIL-H-5606

See TABLES 13-1 & 13-2 for recommended brands.

1. Unfasten and remove pump cover (FIG. 12-1).
2. Check the hydraulic fluid level in reservoir as follows. With Liftgate stowed, or platform at vehicle bed height, level should be as shown in FIG. 12-2.

NOTE: If the hydraulic fluid in the reservoir is contaminated, do the **CHANGING HYDRAULIC FLUID** procedure in this section.

3. If needed, add fluid to the reservoir as follows. Pull out (no threads) filler cap (FIG. 12-2). Fill the reservoir with hydraulic fluid until reservoir looks about half full (FIG. 12-2). Reinstall filler cap (FIG. 12-2).

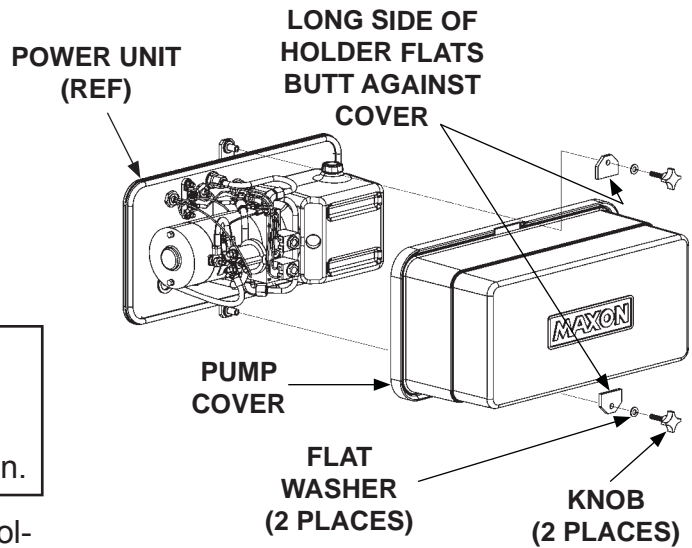

**UNFASTENING / FASTENING
PUMP COVER
FIG. 12-1**

CAUTION

Pump cover must be correctly secured to prevent it from becoming a hazard. To secure pump cover, the long side of the holder flats must butt against pump cover as shown in the illustration.

4. Install and fasten the pump cover as shown in FIG. 12-1. Hand-tighten the cover knobs.

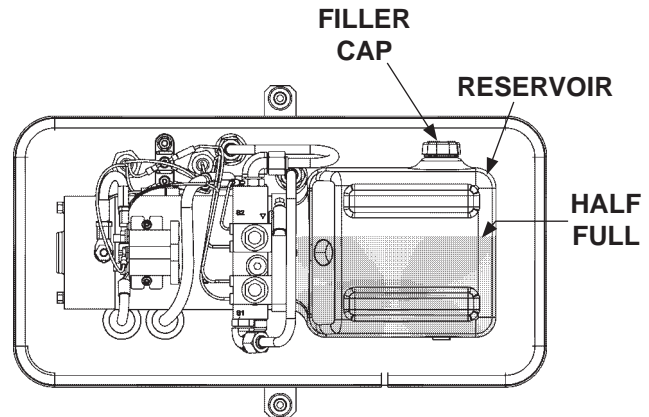

**POWER UNIT FLUID LEVEL
FIG. 12-2**

ISO 32 HYDRAULIC OIL	
RECOMMENDED BRANDS	PART NUMBER
CHEVRON	HIPERSYN 32
KENDALL	GOLDEN MV
SHELL	TELLUS S2 VX 32
EXXONMOBIL	UNIVIS N-32, DTE-24

TABLE 13-1

ISO 15 OR MIL-H-5606 HYDRAULIC OIL	
RECOMMENDED BRANDS	PART NUMBER
CHEVRON	FLUID A, AW-MV-15
KENDALL	GLACIAL BLU
SHELL	TELLUS S2 VX 15
EXXONMOBIL	UNIVIS HVI-13
ROSEMEAD	THS FLUID 17111

TABLE 13-2

PERIODIC MAINTENANCE CHANGING HYDRAULIC FLUID

CAUTION

Keep dirt, water and other contaminants from entering the hydraulic system. Before opening the hydraulic fluid reservoir filler cap, drain plug and hydraulic lines, clean up contaminants that can get in the openings. Also, protect the openings from accidental contamination.

NOTE: Use correct grade of hydraulic fluid for your location.

+50 to +120 Degrees F - Grade ISO 32

Below + 70 Degrees F - Grade ISO 15 or MIL-H-5606

See **TABLES 13-1 & 13-2** for recommended brands.

1. Unfasten and remove pump cover (**FIG. 14-1**). Place empty 5 gallon bucket under drain plug (**FIG. 14-2**).

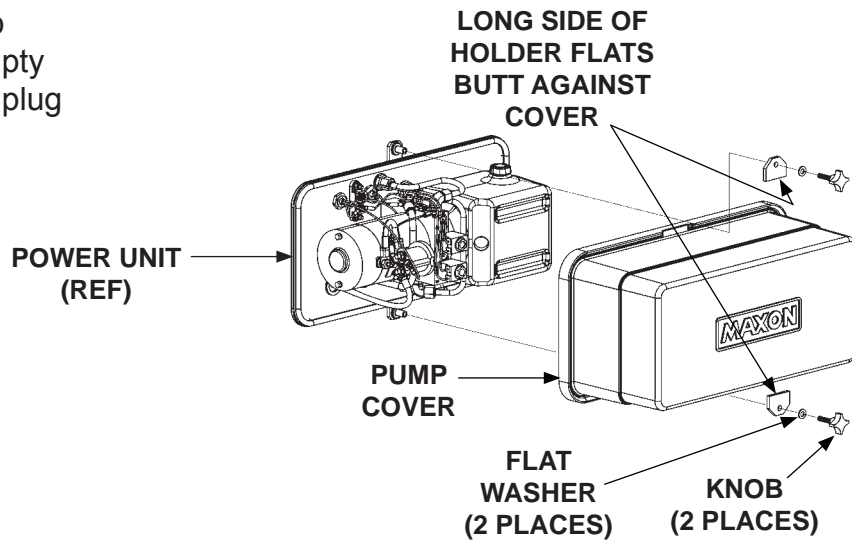

**REMOVING PUMP COVER
FIG. 14-1**

2. Open and raise platform to vehicle bed height. Pull out (no threads) drain plug (**FIG. 14-2**). Drain hydraulic fluid.

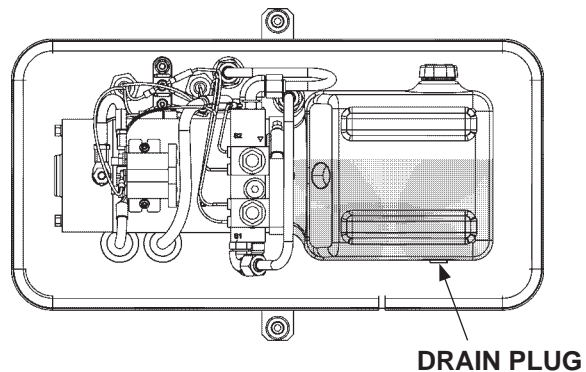

**POWER UNIT
FIG. 14-2**

MAXON

11921 Slauson Ave. Santa Fe Springs, CA. 90670 (800) 227-4116 FAX (888) 771-7713

NOTE: MAXON recommends using dielectric grease on all electrical connections.

3. Disconnect the white wire (**FIG. 15-1**) from the positive (+) power post on the solenoid switch. Lower the platform while draining the remaining hydraulic fluid from system. Reinstall drain plug. Reconnect the white wire to the positive (+) power post on the solenoid switch.
4. Pull out (no threads) filler cap (**FIG. 15-2**). Add 1 gallon of hydraulic fluid to reservoir. The reservoir should look about half full (**FIG. 15-2**). Reinstall filler cap (**FIG. 15-2**).
5. Stow the Lift and do the **CHECKING HYDRAULIC FLUID** procedure in this section of the manual.

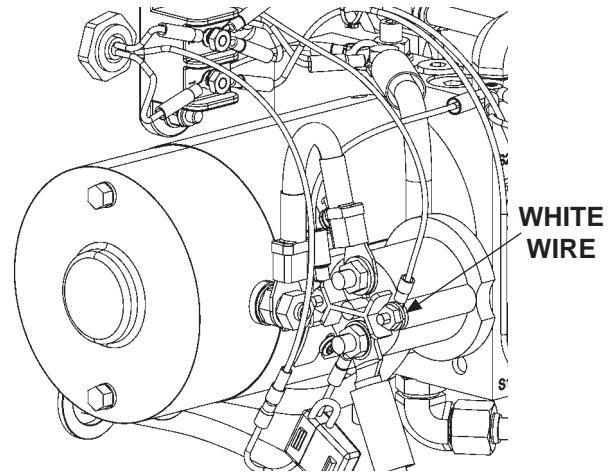

DISCONNECTING WHITE WIRE
FIG. 15-1

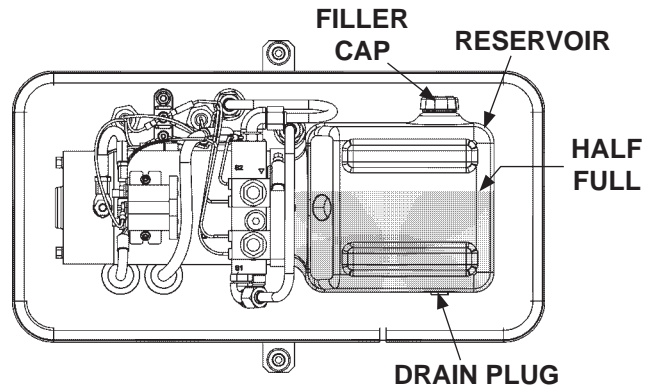

POWER UNIT
FIG. 15-2

CAUTION
Pump cover must be correctly secured to prevent it from becoming a hazard. To secure pump cover, the long side of the holder flats must butt against pump cover as shown in the illustration.

6. Install and fasten the pump cover as shown in **FIG. 15-3**. Hand-tighten the cover knobs.

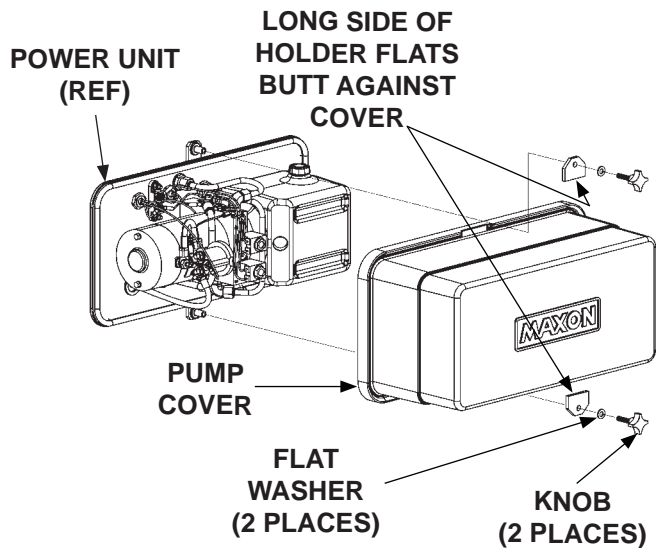

INSTALLING PUMP COVER
FIG. 15-3

PERIODIC MAINTENANCE

REPLACING PLATFORM TORSION SPRING

NOTE: The following procedure shows how to replace torsion spring on RH side of platform. Use this procedure for replacing torsion spring on the LH side.

1. Manually fold flipover onto platform.
2. Raise platform to a convenient work height to gain access and release tension on the torsion spring.

CAUTION

To prevent injury and equipment damage, make sure there is no tension on torsion spring before removing hinge pin.

3. Unbolt hinge pin from hinge bracket (FIG. 16-1). Remove bolt and lock nut. Drive the hinge pin inboard toward the shackle with a hammer and pin punch, just enough to free the torsion spring (FIG. 16-1). Remove spring from shackle.
4. Install the torsion spring as shown in FIG. 16-2. Make sure the long leg of the spring is inserted in the bracket located on shackle (FIG. 16-2). Make sure the short end of the spring is visible and resting against the edge of the hinge bracket (FIG. 16-2).
5. Drive the hinge pin into correct position (FIG. 16-2) through the hinge bracket with a hammer and pin punch. Line up the bolt hole in the hinge pin with the hole in the hinge bracket. Bolt the hinge pin to hinge bracket with bolt and lock nut (FIG. 16-2).
6. Operate the Liftgate to make sure it operates correctly.

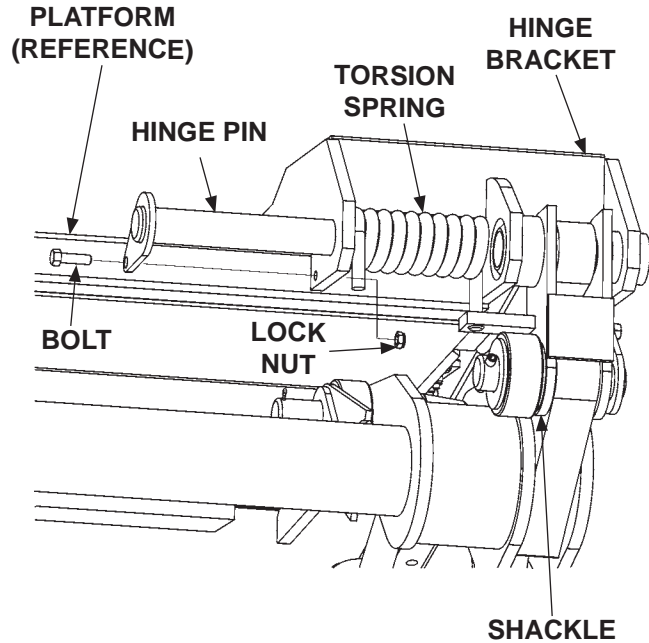

FIG. 16-1

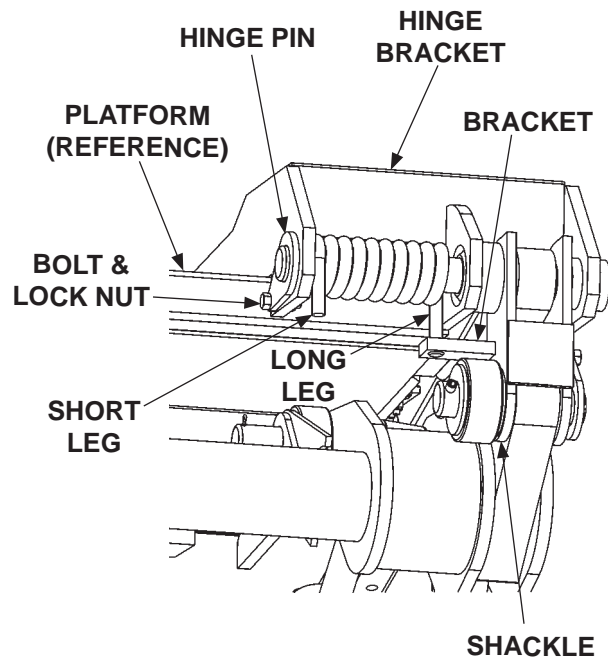
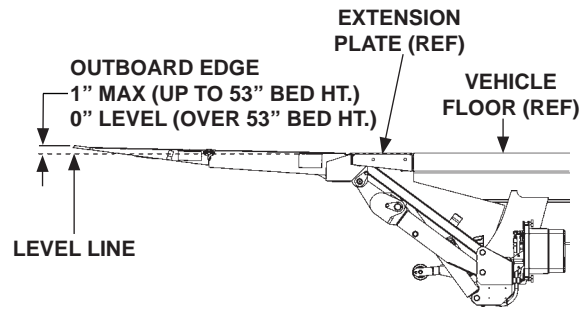

FIG. 16-2

PLATFORM ADJUSTMENT

NOTE: Before doing the following procedure, make sure vehicle is parked on level ground.

1. With the platform and flipover unfolded, raise platform to bed level (**FIG. 17-1**). Measure how much the outboard edge of platform rises above bed level (**FIG. 17-1**). The outboard edge must be level or a maximum of 1" above bed level (**FIG. 17-1**). If indication is correct, Liftgate is installed correctly and no adjustment is needed. If the outboard edge is below bed level, do instructions **2, 3, and 6**. If outboard edge is higher than 1", do instructions **4 through 6**.



PLATFORM EDGE AT OR ABOVE BED LEVEL
FIG. 17-1

2. Compare measurement "A" (**FIG. 17-2**) with the distances and shims in **TABLE 17-1**. For example: If measurement "A" (**FIG. 17-2**) is 1" below level and you want to raise outboard edge of platform 1" above level, use 1/8" shim to raise 2" (**TABLE 17-1**).

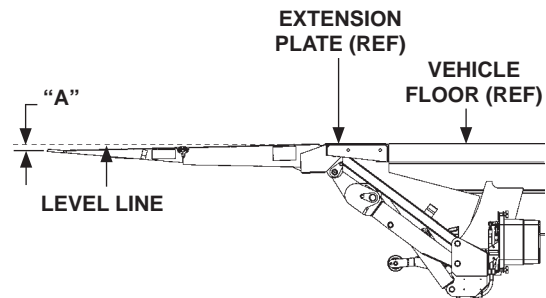

PLATFORM EDGE BELOW BED LEVEL
FIG. 17-2

RAISE PLATFORM EDGE (OUTBOARD) THIS DISTANCE ("A")	REQUIRED SHIM THICKNESS	WELD SIZE "W"
1"	1/16"	1/16"
2"	1/8"	1/8"
3"	3/16"	3/16"
4"	1/4"	1/4"

TABLE 17-1

3. Weld shims (parts bag item) on both platform stops (**FIG. 17-3**) to raise outboard edge of platform to correct position.

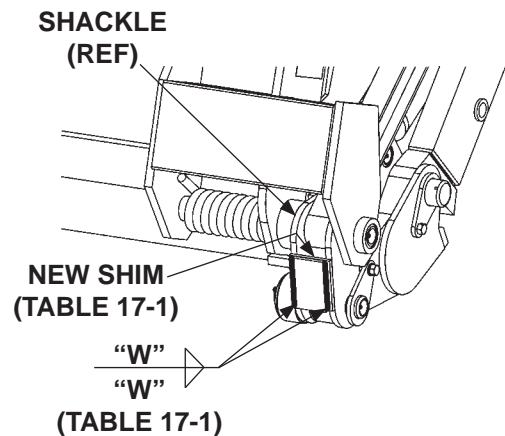

WELDING SHIMS (CURBSIDE SHOWN)
FIG. 17-3

PERIODIC MAINTENANCE

PLATFORM ADJUSTMENT - Continued

MAXON®

11921 Slauson Ave. Santa Fe Springs, CA. 90670 (800) 227-4116 FAX (888) 771-7713

4. Compare measurement "B" (FIG. 18-1) with the distances and grinding depths in TABLE 18-1. For example: If measurement "B" (FIG. 18-1) is 3" above bed level and you want to lower the outboard edge of platform to 1" above bed level, grind 1/8" from each platform stop (TABLE 18-1).

LOWER PLATFORM EDGE (OUTBOARD) THIS DISTANCE ("B")	GRIND METAL FROM PLATFORM STOP
1"	1/16"
2"	1/8"
3"	3/16"
4"	1/4"

TABLE 18-1

5. Grind metal from platform stops (FIG. 18-2) to lower outboard edge of platform to correct position.

6. Lower the platform, then raise it to bed level. The outboard edge of platform should be level or up to 1" maximum above bed level (FIG. 18-3).

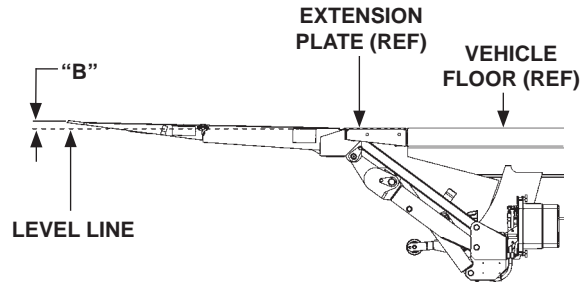

**PLATFORM EDGE ABOVE BED LEVEL
FIG. 18-1**

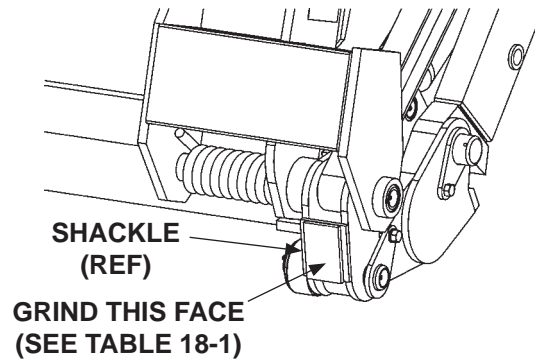

**GRINDING PLATFORM STOPS
(CURBSIDE SHOWN)
FIG. 18-2**

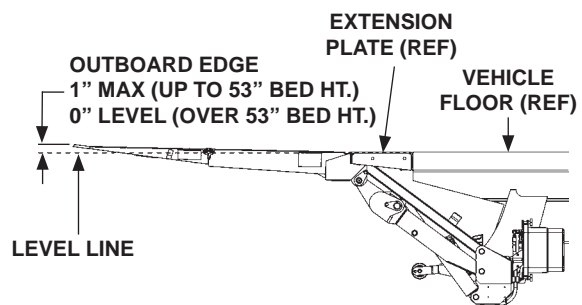

**PLATFORM EDGE ABOVE BED LEVEL
FIG. 18-3**

DECALS (GPT)

NOTE: Ensure there is no residue, dirt or corrosion where decals are attached. If necessary, clean surface before attaching decals.

NOTE: Preferred decal layout is shown. Decals on the Liftgate are attached at the factory. If vehicle does not permit this layout, decals in the manual and decal kit must be applied so that they are easily visible when approaching vehicle to operate Liftgate. Use good common sense when locating these decals on vehicle.

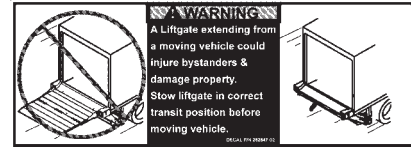

STOW WARNING DECAL
P/N 282847-02



MAXON NAME PLATE
P/N 280004-01

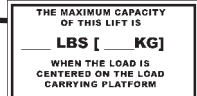
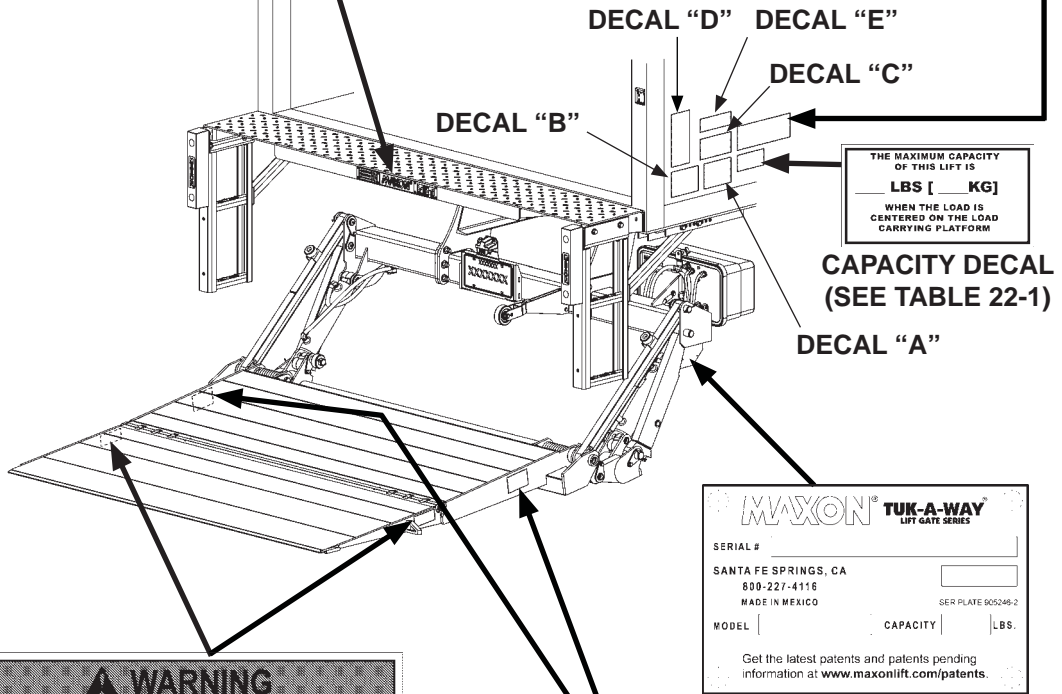

CAPACITY DECAL
(SEE TABLE 22-1)

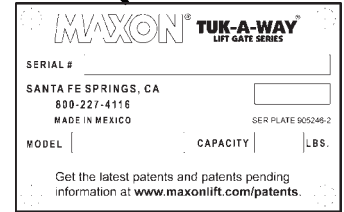

SERIAL PLATE
(REF)

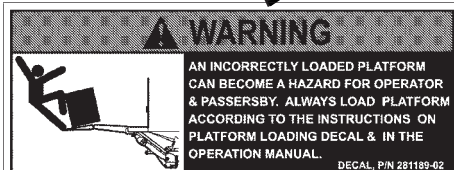

PLATFORM WARNING DECAL
P/N 281189-02
(2 PLACES)

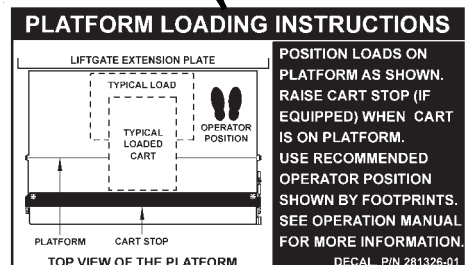

PLATFORM LOADING DECAL
P/N 281326-01
(2 PLACES)

FIG. 19-1

MAXON 11921 Slauson Ave. Santa Fe Springs, CA. 90670 (800) 227-4116 FAX (888) 771-7713

SAFETY INSTRUCTIONS

Read all decals and operation manual before operating liftgate.

1. Do not use liftgate unless you have been properly instructed and have read, and are familiar with, the operating instructions.
2. Be certain vehicle is properly and securely braked before using the liftgate.
3. Always inspect this liftgate for maintenance or damage before using it. Do not use liftgate if it shows any sign of damage or improper maintenance.
4. Do not overload
5. Make certain the area in which the platform will open and close is clear before opening or closing the platform.
6. Make certain platform area, including the area in which loads may fall from platform, is clear before and at all times during operation of liftgate.
7. This liftgate is intended for loading and unloading of cargo only. Do not use this liftgate for anything but its intended use.

(A)

WARNING

Read this information carefully.

- Improper operation of this Liftgate can result in serious personal injury. If you do not have a copy of the operating instructions, please obtain them from your employer, distributor, or lessor before you attempt to operate Liftgate.
- If there are signs of improper maintenance, damage to vital parts, or slippery platform surface, do not use the Liftgate until these problems have been corrected.
- If you are using a pallet jack, be sure it can be maneuvered safely.
- Do not operate a forklift on the platform.
- Do not allow any part of yours or your helper's body to be placed under, within, or around any portion of the moving Liftgate, or its mechanisms, or in a position that would trap them between the platform and the ground or truck when the Liftgate is operated.
- If a helper is riding the platform with you, make sure you are both doing so safely and that you are not in danger of coming in contact with any moving or potentially moving obstacles.
- **USE GOOD COMMON SENSE.**
- If load appears to be unsafe, do not lift or lower it.

For a free copy of other manuals that pertain to this model Liftgate, please visit our website at www.maxonlift.com or call Customer Service at (800) 227-4116

(B)



WARNING

Liftgate hazards can result in crushing or falling.

Keep hands and feet clear of pinch points.

If riding liftgate, make sure load is stable and footing is solid.

(C)

Read and understand all instructions and WARNINGS before use.

OPERATING INSTRUCTIONS

OPERATE

STOW

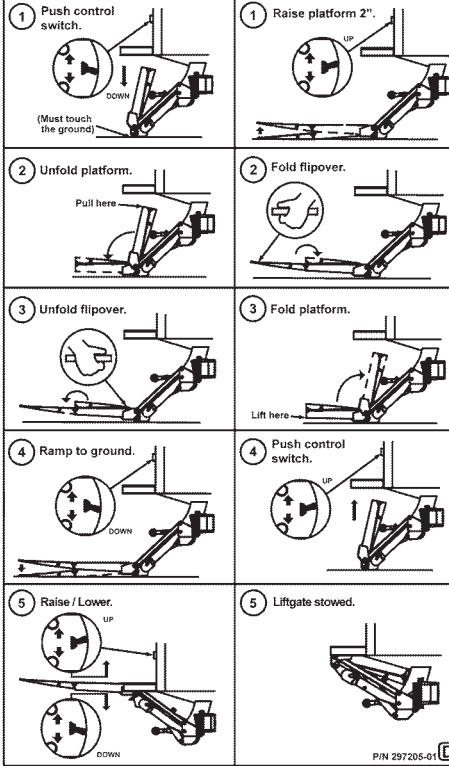

DECAL SHEET
P/N 297205-01
FIG. 20-1

MODEL	DECAL P/N	CAPACITY DECAL
GPT-25	220382	2500 POUNDS
GPT-3	220388	3000 POUNDS
GPT-4	296274-01	4000 POUNDS
GPT-5	296274-02	5000 POUNDS

CAPACITY DECAL
TABLE 20-1

DECALS (GPTWR)

NOTE: Ensure there is no residue, dirt or corrosion where decals are attached. If necessary, clean surface before attaching decals.

NOTE: Preferred decal layout is shown. Decals on the Liftgate are attached at the factory. If vehicle does not permit this layout, decals in the manual and decal kit must be applied so that they are easily visible when approaching vehicle to operate Liftgate. Use good common sense when locating these decals on vehicle.

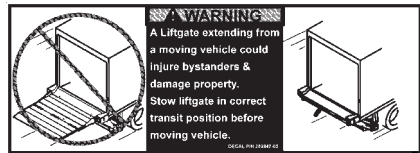

STOW WARNING DECAL
P/N 282847-02



MAXON NAME PLATE
P/N 280004-01

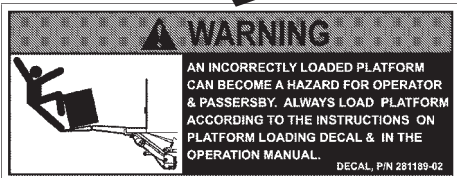
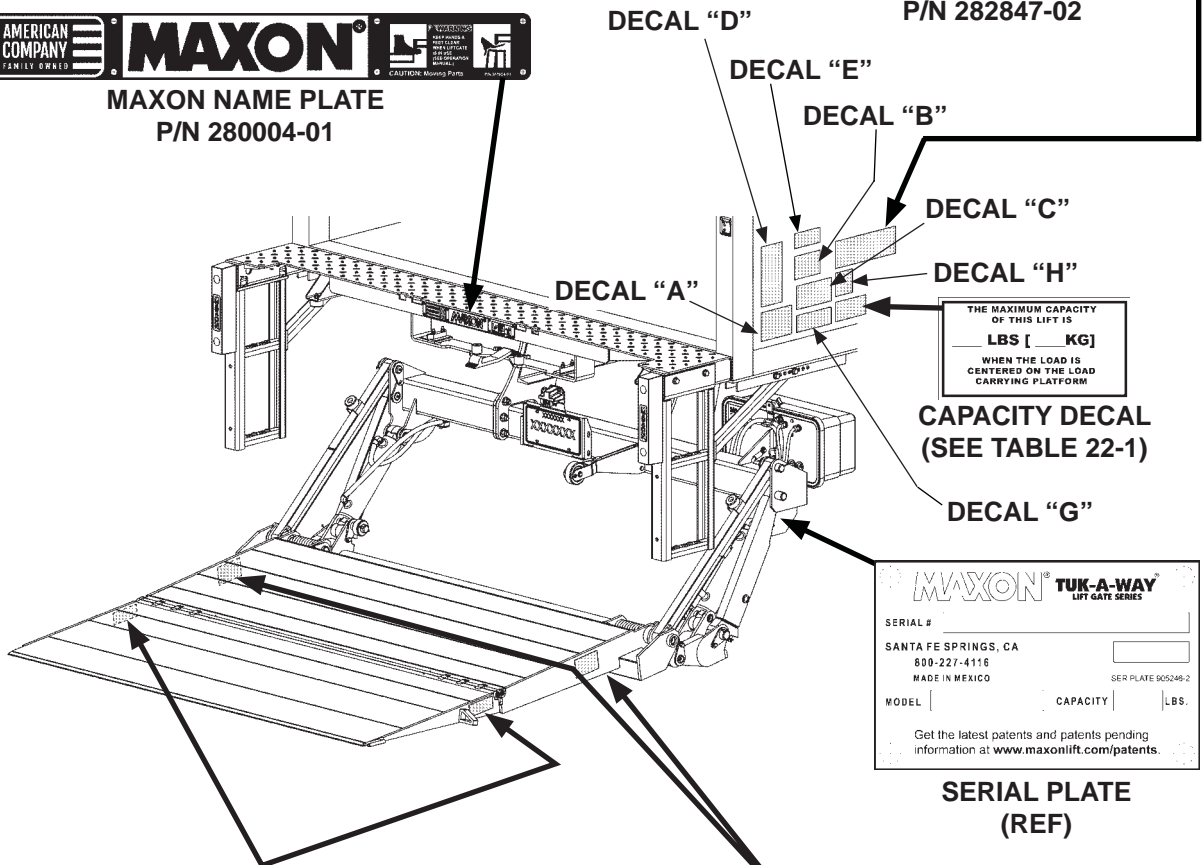

PLATFORM WARNING DECAL
P/N 281189-02
(2 PLACES)

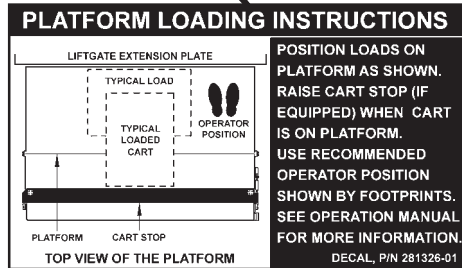

PLATFORM LOADING DECAL
P/N 281326-01
(2 PLACES)

FIG. 21-1

SAFETY INSTRUCTIONS

Read all decals and operation manual before operating liftgate.

- Do not use liftgate unless you have been properly instructed and have read, and are familiar with, the operating instructions.
- Be certain vehicle is properly and securely braked before using the liftgate.
- Always inspect this liftgate for maintenance or damage before using it. Do not use liftgate if it shows any sign of damage or improper maintenance.
- Do not overload
- Make certain the area in which the platform will open and close is clear before opening or closing the platform.
- Make certain platform area, including the area in which loads may fall from platform, is clear before and at all times during operation of liftgate.
- This liftgate is intended for loading and unloading of cargo only. Do not use this liftgate for anything but its intended use.

(A)

SAFETY INSTRUCTIONS

- Read **WARNING** decal for the walk ramp before you set up walk ramp & stow walk ramp.
- To set up walk ramp & stow walk ramp, refer to walk ramp manufacturer's instructions.

(G)

WARNING

Read this information carefully.

- Improper operation of this Liftgate can result in serious personal injury. If you do not have a copy of the operating instructions, please obtain them from your employer, distributor, or lessor before you attempt to operate Liftgate.
- If there are signs of improper maintenance, damage to vital parts, or slippery platform surface, do not use the Liftgate until these problems have been corrected.
- If you are using a pallet jack, be sure it can be maneuvered safely.
- Do not operate a forklift on the platform.
- Do not allow any part of yours or your helper's body to be placed under, within, or around any portion of the moving Liftgate, or its mechanisms, or in a position that would trap them between the platform and the ground or truck when the Liftgate is operated.
- If a helper is riding the platform with you, make sure you are both doing so safely and that you are not in danger of coming in contact with any moving or potentially moving obstacles.
- USE GOOD COMMON SENSE.**
- If load appears to be unsafe, do not lift or lower it.

For a free copy of other manuals that pertain to this model Liftgate, please visit our website at www.maxonlift.com or call Customer Service at (800) 227-4116.

(B)



WARNING

Liftgate hazards can result in crushing or falling.

Keep hands and feet clear of pinch points.

If riding liftgate, make sure load is stable and footing is solid.

(C)

Read and understand all instructions and WARNINGS before use.

OPERATING INSTRUCTIONS

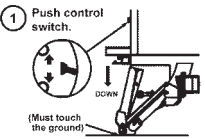
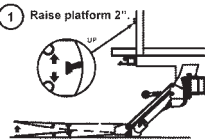
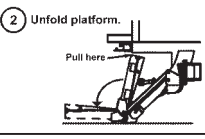
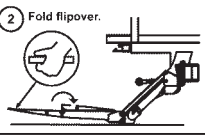
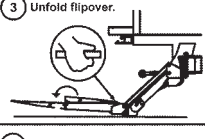
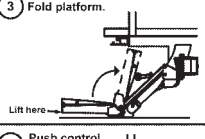
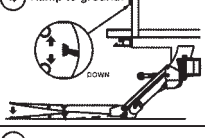
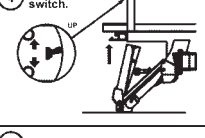
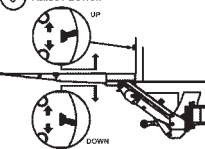
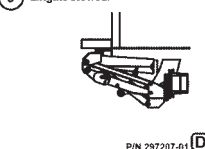
OPERATE	STOW
<p>1 Push control switch.</p> 	<p>1 Raise platform 2".</p> 
<p>2 Unfold platform.</p> 	<p>2 Fold flipover.</p> 
<p>3 Unfold flipover.</p> 	<p>3 Fold platform.</p> 
<p>4 Ramp to ground.</p> 	<p>4 Push control switch.</p> 
<p>5 Raise / Lower.</p> 	<p>5 Liftgate stowed.</p> 

P/N 297207-01 (D)

CAUTION

Always stand clear of platform area.

(E)

WARNING



Never operate liftgate when walk ramp is extended.

Always stow ramp before operating liftgate.

(H)

DECAL SHEET
P/N 297207-01
FIG. 22-1

MODEL	DECAL P/N	CAPACITY DECAL
GPTWR-25	220382	2500 POUNDS
GPTWR-3	220388	3000 POUNDS
GPTWR-4	296274-01	4000 POUNDS
GPTWR-5	296274-02	5000 POUNDS

CAPACITY DECAL
TABLE 22-1

SYSTEM DIAGRAMS

PUMP, MOTOR & SOLENOID OPERATION

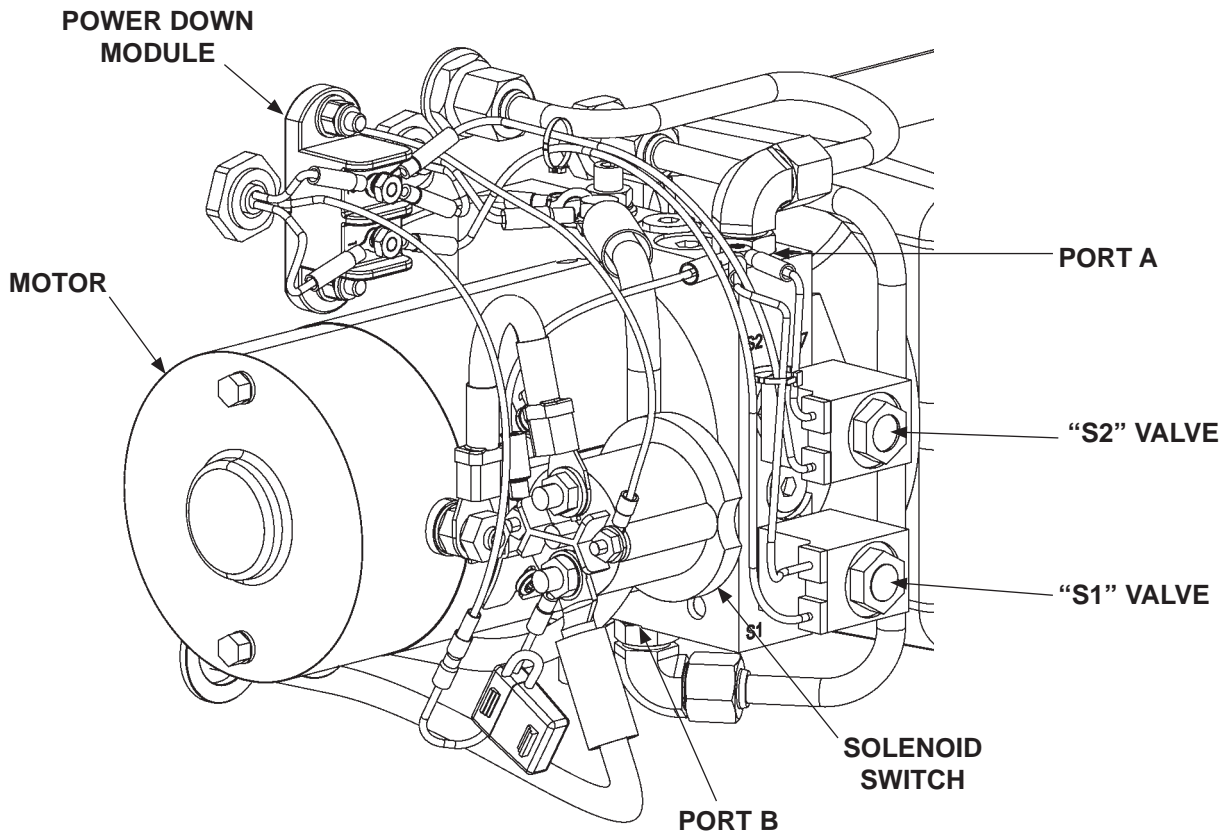

POWER UNIT
FIG. 23-1

NOTE: Hydraulic lock valve is on the RH cylinder.

POWER UNIT MOTOR & SOLENOID OPERATION						
LIFTGATE FUNCTION	PORT	SOLENOID OPERATION (✓ MEANS ENERGIZED)				POWER DOWN MODULE
		MOTOR	VALVE "S2"	VALVE "S1"	LOCK VALVE	
RAISE	A	✓	-	✓	-	-
LOWER	B	✓	✓	-	✓	✓
REFER TO VALVES SHOWN ON HYDRAULIC SCHEMATIC						

TABLE 23-1

SYSTEM DIAGRAMS - Continued

HYDRAULIC SCHEMATIC (POWER DOWN)

MAXON[®]
 11921 Slauson Ave. Santa Fe Springs, CA. 90670 (800) 227-4116 FAX (888) 771-7713

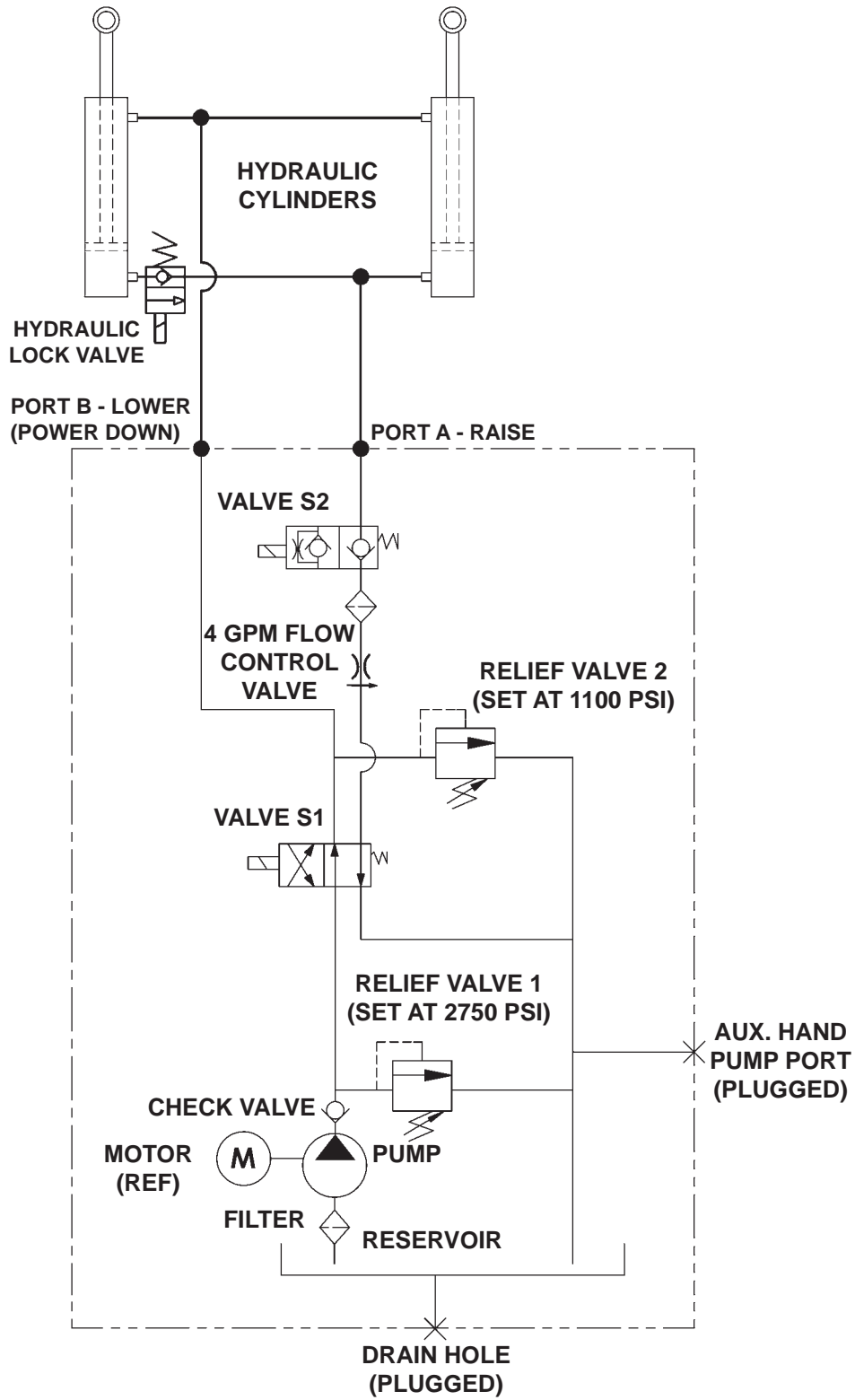

FIG. 24-1

ELECTRICAL SCHEMATIC (POWER DOWN)

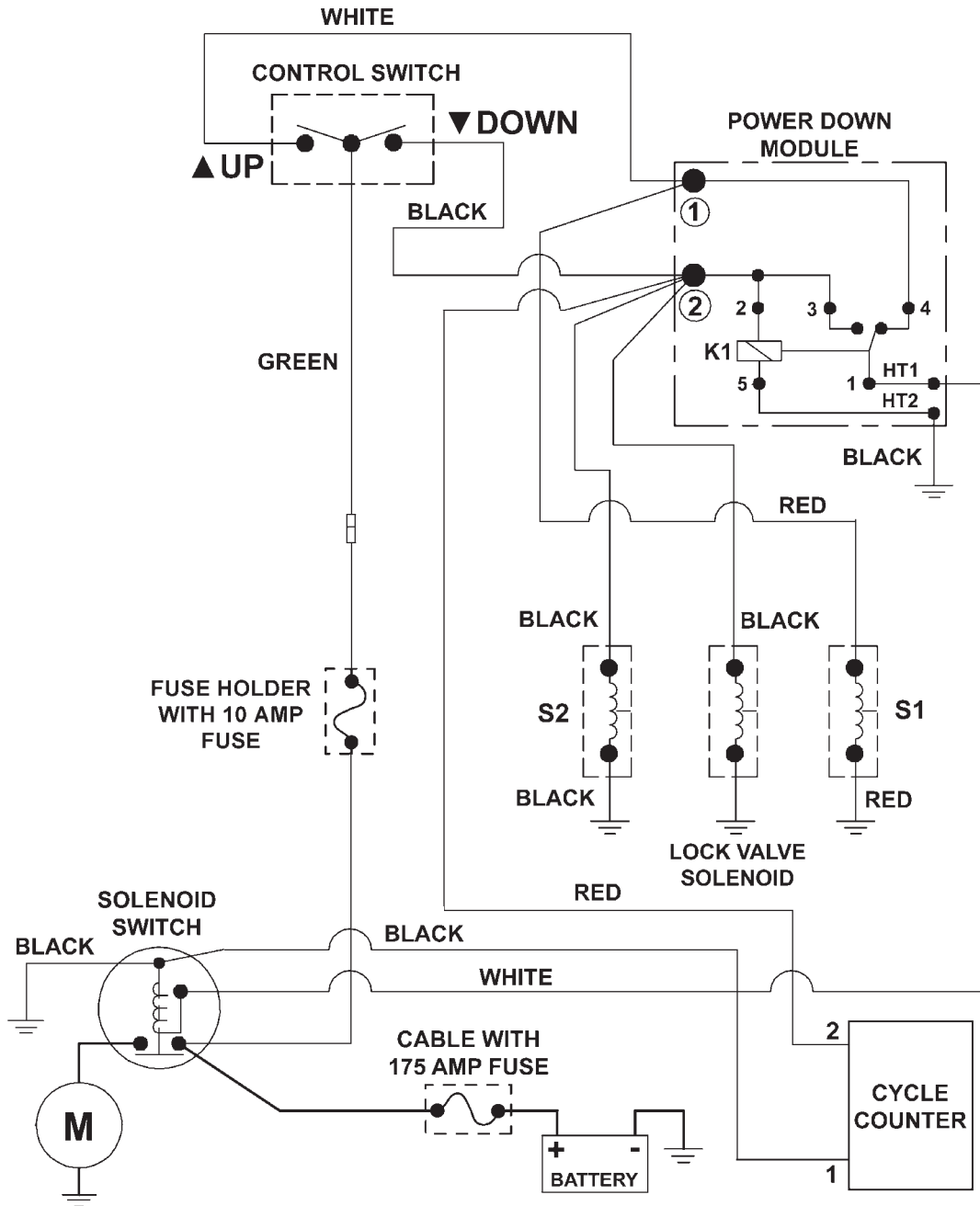

FIG. 25-1

SYSTEM DIAGRAMS

GPT/GPTWR ELECTRICAL VALUES

Solenoid Switch	12V	24V
Coil Resistance:	5.4Ω @70°F. ±15%	20.1Ω @70°F. ±15%
Ampere:	2.2A	1.2A
Coil terminal torque: 10-15 lb-in max.		
Contact terminal torque: 30-35 lb-in max.		
Solenoid Valves (A, S1, & S2)		
Coil Resistance:	4.0Ω @ 70°F. ±15%	26.7Ω @ 70°F. ±15%
Ampere:	3A, 2.5A @10V	
Coil terminal torque: 15-45 lb-in max.		
Valve cartridge torque: 25-30 lb-ft max.		
Coil nut torque: 15-45 lb-in		
Solenoid Lock Valve		
Coil Resistance:	8.0Ω @ 70°F. ±15%	30Ω @ 70°F. ±15%
Ampere:	1.5A	0.8A
Coil terminal torque: 3-4.5 lb-ft max.		
Valve cartridge torque: 18.5-22 lb-ft max.		
Ground Cable		
Cap Screw Torque: 24 lb-ft max.		

TABLE 26-1

MAXON®

11921 Slauson Ave. Santa Fe Springs, CA. 90670 (800) 227-4116 FAX (888) 771-7713

THIS PAGE INTENTIONALLY LEFT BLANK

TROUBLESHOOTING

PLATFORM WILL NOT RAISE & MOTOR WILL NOT RUN

1. Connect voltmeter between solenoid switch terminal “B” and ground wires connection on pump (FIG. 28-1). Verify that full battery voltage is at “B.” Recharge the battery if voltmeter indicates less than 12.4 volts DC.
2. Connect voltmeter between solenoid switch terminal “D” and ground wires connection on pump (FIG. 28-1). Set control switch to “UP.” Verify that full battery voltage is at “D”. If the voltage at “D” is less, replace the power down module.
3. Touch a jumper wire to terminals “B” & “D” (FIG. 28-1). If motor runs, check control switch, the switch connections, and white wire. Check and correct wiring connections or replace the control switch.
4. Touch heavy jumper cables to terminals “A” & “B” (FIG. 28-1).
 - a. If motor runs, replace the solenoid switch.
 - b. If motor does not run, repair or replace the pump motor.

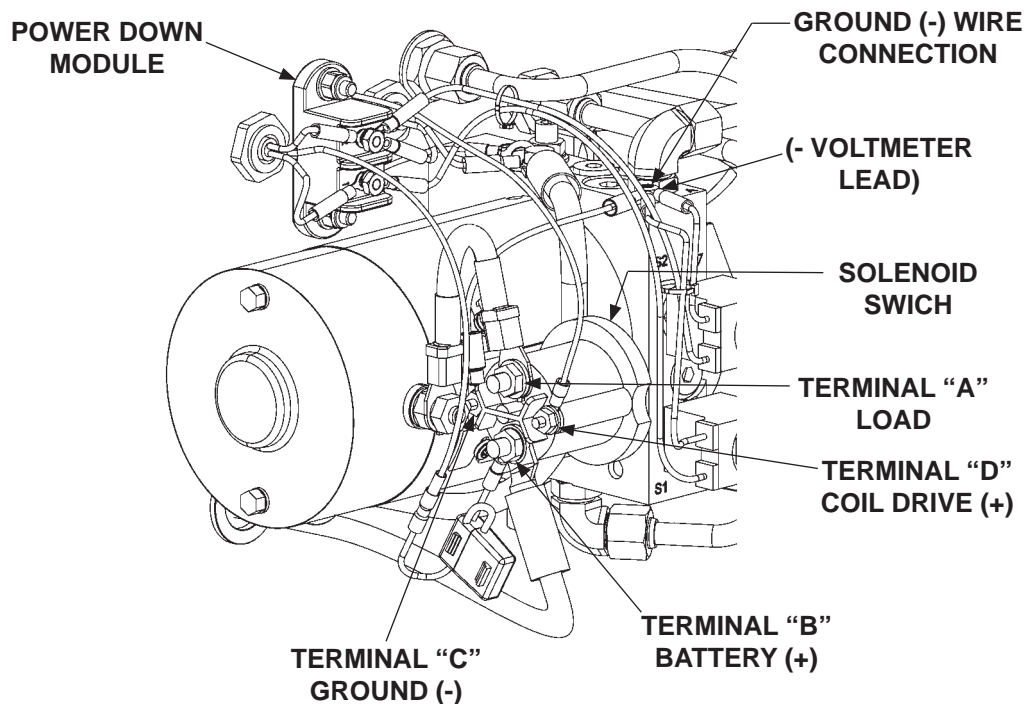

FIG. 28-1

PLATFORM WILL NOT RAISE, BUT MOTOR RUNS

1. Do the **CHECKING HYDRAULIC FLUID** procedure in this manual. If necessary, add hydraulic fluid.
2. Check for the following. (Refer to **ELECTRICAL SCHEMATIC**.)
 - Ground connections are clean and tight at battery and pump. Clean and/or tighten if necessary.
 - The **(+)** and **(-)** battery cable connections are clean and tight at battery and pump. Clean and/or tighten if necessary.
 - Voltage drops on battery/power cables (use voltmeter). Clean and/or tighten connections or replace cables that indicate voltage drops.
3. Check for structural damage and replace worn parts.

CAUTION

Keep dirt, water and other contaminants from entering the hydraulic system. Before opening the hydraulic fluid reservoir filler cap, drain plug and hydraulic lines, clean up contaminants that can get in the openings. Also, protect the openings from accidental contamination during maintenance.

NOTE: In most cases, you can avoid having to manually bleed hydraulic system by correctly positioning Liftgate platform before disconnecting any lifting cylinder high pressure hydraulic lines.

4. Check pump oil filter in the reservoir (**FIG. 29-1**). Clean or replace filter, if necessary.
5. Check for dirty 2750 psi relief valve (**FIG. 29-1**). Clean or replace relief valve, if necessary.

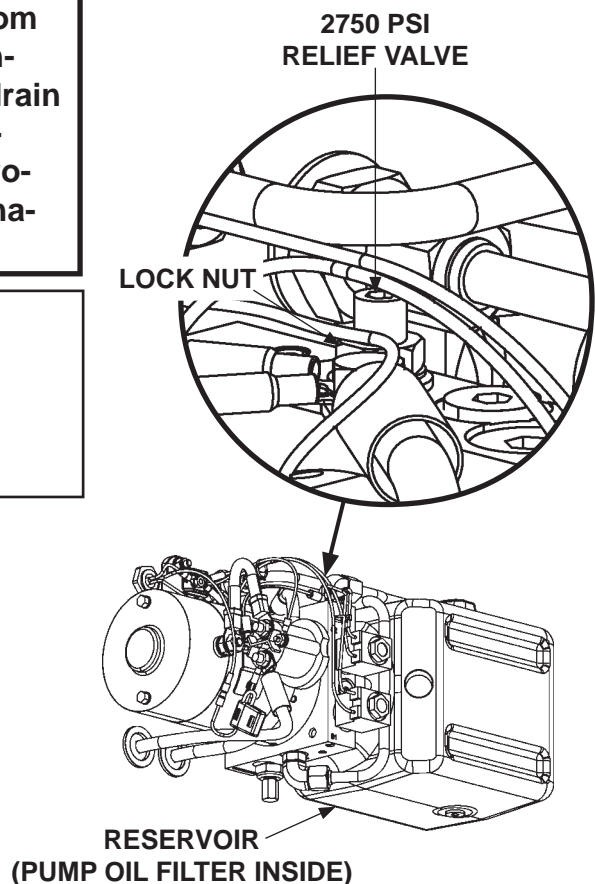

**CHECKING 2750 PSI RELIEF VALVE
FIG. 29-1**

PLATFORM RAISES BUT LEAKS DOWN

1. Check if the “S2” (lowering) solenoid valve is constantly energized. Connect voltmeter negative (-) lead to ground (-) wires connection on pump and positive (+) lead to (+) terminal on the “S2” (lowering) solenoid valve (FIG. 30-1). If voltmeter indicates battery voltage, check for faulty wiring or toggle switch.

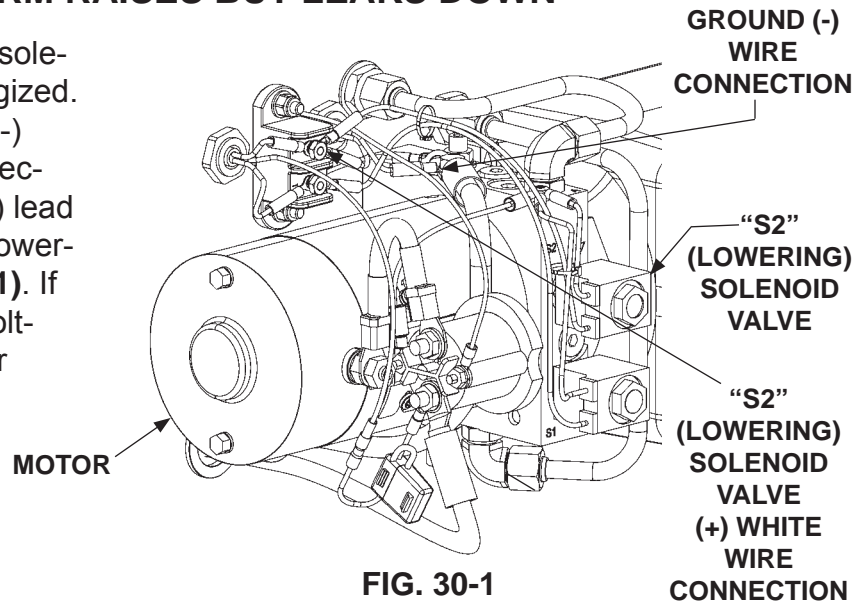
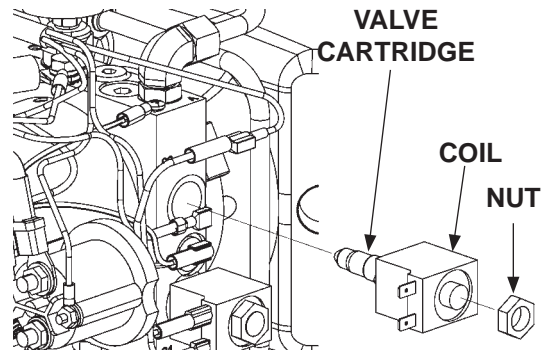

FIG. 30-1

CAUTION
 Keep dirt, water and other contaminants from entering the hydraulic system. Before opening the hydraulic fluid reservoir filler cap, drain plug and hydraulic lines, clean up contaminants that can get in the openings. Also, protect the openings from accidental contamination during maintenance.

NOTE: In most cases, you can avoid having to manually bleed hydraulic system by correctly positioning Liftgate platform before disconnecting any lifting cylinder high pressure hydraulic lines.

2. Make sure platform is on the ground. Remove lowering solenoid valve (FIG. 30-2). Push on the plunger in the valve by inserting small screwdriver in the open end (FIG. 30-3). If the plunger does not move with a smooth, spring-loaded action (approximately 1/8”), replace the valve cartridge. Reinstall lowering solenoid valve. Torque valve cartridge to 30 lbs.-ft. and hex nut to 30 lbs.-in.



**REMOVING SOLENOID VALVE
 FIG. 30-2**

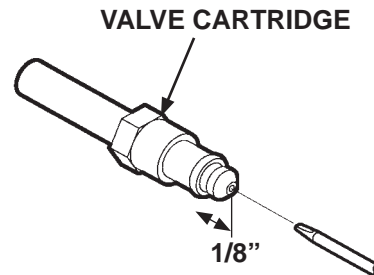

**CHECKING SOLENOID VALVE
 FIG. 30-3**

3. Check the hydraulic cylinder. With the platform at vehicle floor level, remove the hydraulic line from the **LOWER** port on the cylinder (**FIG. 31-1**). Hold the control switch in the **UP** position for two seconds while you watch for hydraulic fluid at the **LOWER** port. A few drops of hydraulic fluid escaping the port is normal. However, if fluid streams out, piston seals are worn. Replace seals.

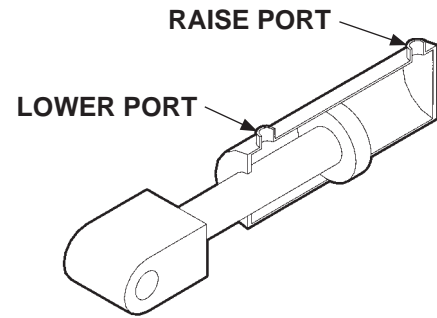

FIG. 31-1

PLATFORM RAISES PARTIALLY AND STOPS

1. Lower the opened platform to the ground. Do the **CHECKING HYDRAULIC FLUID** procedure in this manual. If necessary, add hydraulic fluid.
2. Use voltmeter to verify the battery voltage is 10.5 volts or more under load from pump motor.
3. Check for structural damage and poor lubrication. Replace worn parts.

CAUTION

Keep dirt, water and other contaminants from entering the hydraulic system. Before opening the hydraulic fluid reservoir filler cap, drain plug and hydraulic lines, clean up contaminants that can get in the openings. Also, protect the openings from accidental contamination during maintenance.

NOTE: In most cases, you can avoid having to manually bleed hydraulic system by correctly positioning Liftgate platform before disconnecting any lifting cylinder high pressure hydraulic lines.

4. Check for dirty 2750 psi relief valve (**FIG. 32-1**). Clean or replace 2750 psi relief valve, if necessary.
5. Check the hydraulic cylinder. With the platform at vehicle floor level, remove the hydraulic line from the **LOWER** port on the cylinder (**FIG. 32-2**). Hold the control switch in the **UP** position for two seconds while you watch for hydraulic fluid at the **LOWER** port. A few drops of hydraulic fluid escaping the port is normal. However, if fluid streams out, piston seals are worn. Replace seals.
6. Check pump oil filter in the reservoir (**FIG. 32-1**). Clean or replace filter, if necessary.

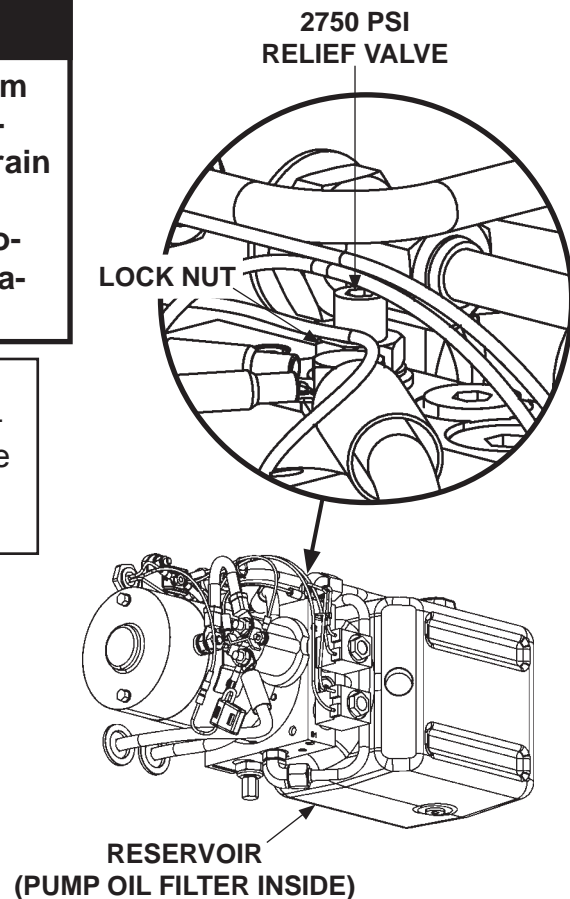

FIG. 32-1

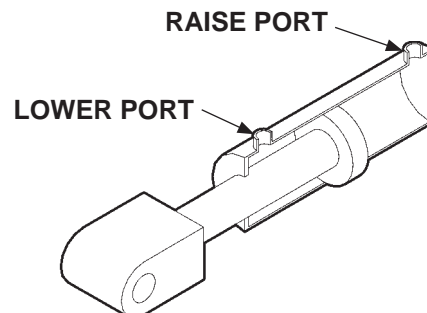

FIG. 32-2

LIFTGATE WILL NOT LIFT RATED CAPACITY

1. Use voltmeter to verify the battery voltage is 10.5 volts or more under load from pump motor.
2. Check for structural damage or lack of lubrication. Replace worn parts.

CAUTION

Keep dirt, water and other contaminants from entering the hydraulic system. Before opening the hydraulic fluid reservoir filler cap, drain plug and hydraulic lines, clean up contaminants that can get in the openings. Also, protect the openings from accidental contamination during maintenance.

NOTE: In most cases, you can avoid having to manually bleed hydraulic system by correctly positioning Liftgate platform before disconnecting any lifting cylinder high pressure hydraulic lines.

CAUTION

Before disconnecting UP line, ensure DOWN line & elbow are connected to port B.

3. Check the 2750 psi relief valve as follows. With platform on the ground, disconnect UP line from Port "A" and remove elbow (FIG. 33-1). Install 0-3000 psi pressure gauge in Port "A" (FIG. 33-1). Loosen relief valve lock nut and hold the control switch in the **UP** position. Adjust the relief valve until the gauge reads 2750 psi (FIG. 33-1). Remove gauge and reinstall elbow and up line. Then, reinstall relief valve cover.
4. Check if pump relief valve is dirty. Clean or replace relief valve, if necessary.
5. Check the hydraulic cylinder. With the platform at vehicle floor level, remove the hydraulic line from the **LOWER** port on the cylinder (FIG. 33-2). Hold the control switch in the **UP** position for two seconds while you watch for hydraulic fluid at the **LOWER** port. A few drops of hydraulic fluid escaping the port is normal. However, if fluid streams out, piston seals are worn. Replace seals.
6. If pump cannot produce 2750 psi or lift the load capacity with a minimum of 12.6 volts available, the pump is worn and needs to be replaced.

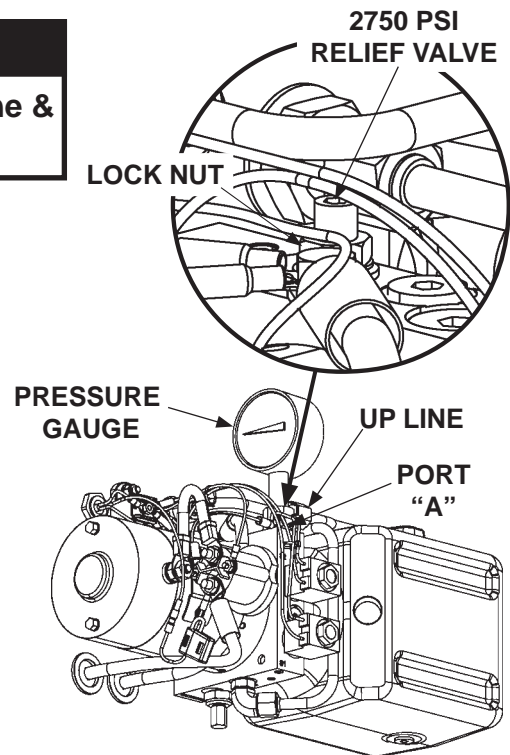

FIG. 33-1

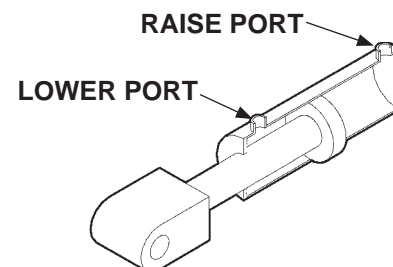

FIG. 33-2

PLATFORM RAISES SLOWLY

1. Connect voltmeter between solenoid switch terminal "B" and ground (-) wires connection on pump (FIG. 34-1). Verify that full battery voltage is at "B." Recharge the battery if voltmeter indicates less than 12.4 volts DC.

CAUTION

Keep dirt, water and other contaminants from entering the hydraulic system. Before opening the hydraulic fluid reservoir filler cap, drain plug and hydraulic lines, clean up contaminants that can get in the openings. Also, protect the openings from accidental contamination during maintenance.

NOTE: In most cases, you can avoid having to manually bleed hydraulic system by correctly positioning Liftgate platform before disconnecting any lifting cylinder high pressure hydraulic lines.

2. Check the hydraulic cylinder. With the platform at vehicle floor level, remove the hydraulic line from the **LOWER** port on the cylinder (FIG. 34-2). Hold the control switch in the **UP** position for two seconds while you watch for hydraulic fluid at the **LOWER** port. A few drops of hydraulic fluid escaping the port is normal. However, if fluid streams out, piston seals are worn. Replace seals.

CAUTION

To prevent damage to flow control valve, do not disassemble the valve.

3. Check the flow control valve as follows. Remove lowering solenoid valve and flow control valve (FIG. 34-3). Ensure the flow control valve operates with a smooth spring-loaded action. Check for debris inside the valve. Clean or replace the flow control valve, if necessary. Reinstall flow control valve (if good) or a replacement. Then, reinstall the lowering solenoid valve. **Torque valve cartridge to 30 lbs.-ft. and hex nut to 30 lbs.-in.**

GROUND (-) WIRES CONNECTION

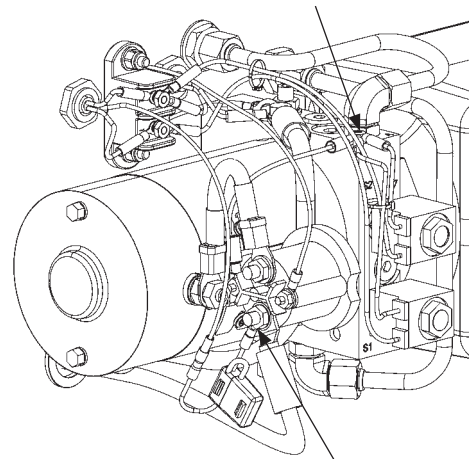

TERMINAL "B"
BATTERY (+)

FIG. 34-1

RAISE PORT

LOWER PORT

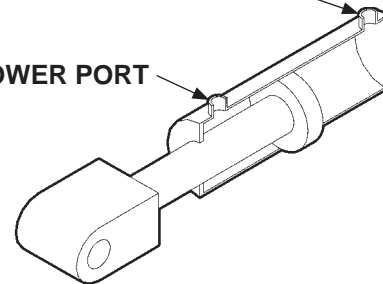
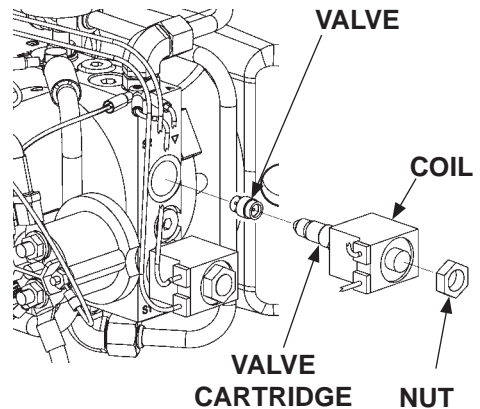

FIG. 34-2

FLOW CONTROL VALVE



VALVE
CARTRIDGE NUT

FIG. 34-3

4. Verify the pump motor is grounded to vehicle frame.
5. Check for leaking hoses and fittings. Tighten or replace as required.
6. Check for structural damage and poor lubrication. Replace worn parts.
7. Check pump oil filter in the reservoir (**FIG. 35-1**). Clean or replace filter, if necessary.

CAUTION

Before disconnecting UP line, ensure DOWN line & elbow are connected to port B.

8. Check the 2750 psi relief valve as follows. With platform on the ground, disconnect UP line from Port "A" and remove elbow (**FIG. 35-1**). Install 0-3000 psi pressure gauge in Port "A" (**FIG. 35-1**). Loosen relief valve lock nut and hold the control switch in the **UP** position. Adjust the relief valve until the gauge reads 2750 psi (**FIG. 35-1**). Remove gauge and reinstall elbow and up line. Then, reinstall relief valve cover.

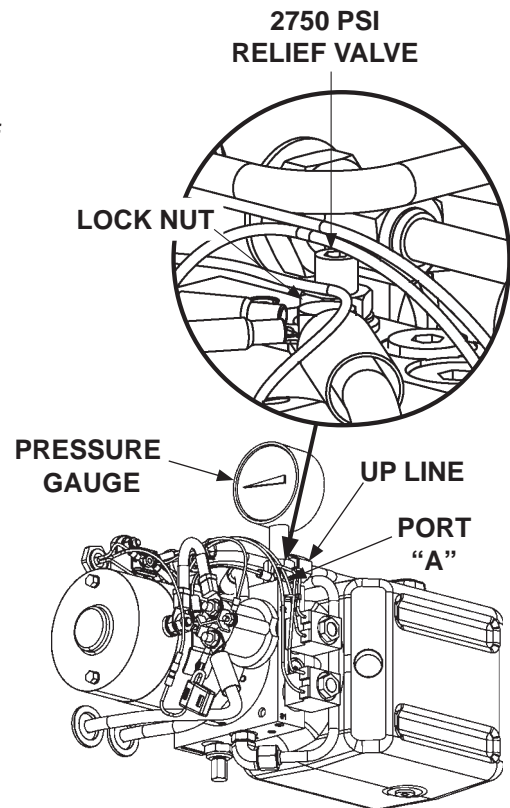

FIG. 35-1

PLATFORM WILL NOT LOWER, LOWERS TOO SLOWLY OR TOO QUICKLY

1. Connect voltmeter (+) lead to solenoid switch terminal “B” and the (-) lead to the ground wires connection on pump (**FIG. 36-1**). Verify that full battery voltage is at “B.” Recharge the battery if voltmeter indicates less than 12.4 volts DC.
2. Check for structural damage or poor lubrication. Replace worn parts.
3. Check if the “D” terminal and “S2” (lowering) solenoid valve are getting battery voltage (**FIG. 36-1**). Connect voltmeter negative (-) lead to ground (-) wires connection on pump and positive (+) lead to the “D” terminal (**FIG. 36-1**). Hold control switch in the **DOWN** position. Then, connect voltmeter (+) lead to (+) terminal on the “S2” (lowering) solenoid valve (**FIG. 36-1**). Voltage may be as low as 10.5 volts DC. If voltmeter shows a much lower reading or a reading of 0 volts, check for faulty control switch and wiring, battery cable, ground wire connections in pump assembly, and pump motor.

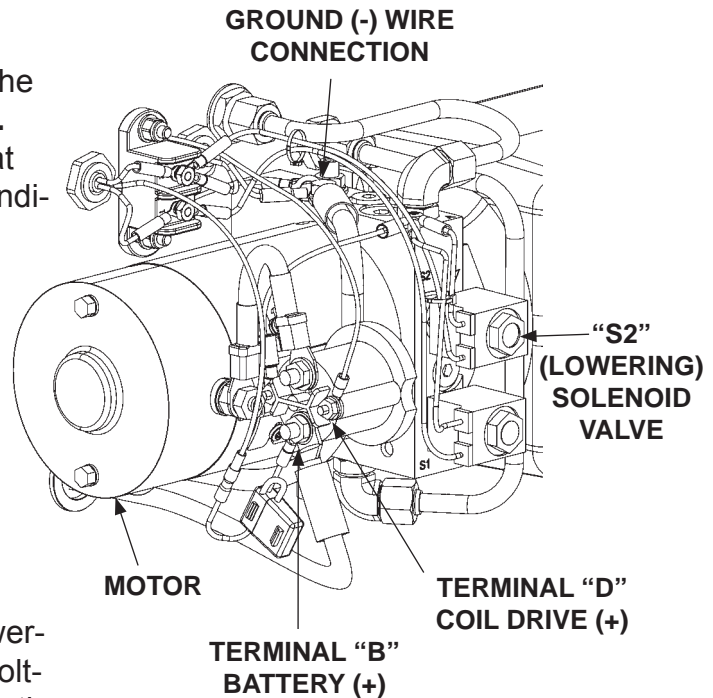

FIG. 36-1

CAUTION

Keep dirt, water and other contaminants from entering the hydraulic system. Before opening the hydraulic fluid reservoir filler cap, drain plug and hydraulic lines, clean up contaminants that can get in the openings. Also, protect the openings from accidental contamination during maintenance.

NOTE: In most cases, you can avoid having to manually bleed hydraulic system by correctly positioning Liftgate platform before disconnecting any lifting cylinder high pressure hydraulic lines.

4. Make sure platform is on the ground. Check the flow control valve as follows. Remove lowering solenoid valve and flow control valve (**FIG. 37-1**). Ensure the flow control valve operates with a smooth spring-loaded action. Check for debris inside the valve. Clean or replace the flow control valve, if necessary. Reinstall flow control valve (if good) or a replacement.

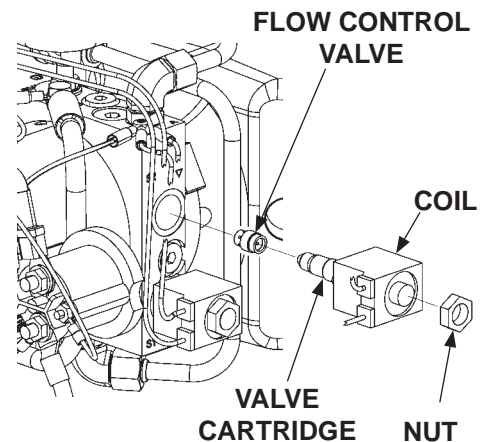
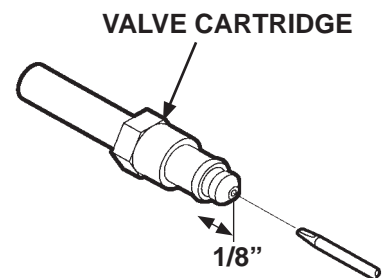

FIG. 37-1

CAUTION

To prevent damage to flow control valve, do not disassemble the valve.

5. Check the lowering solenoid valve as follows. Check if filtering screen is plugged. Clean carefully if required. Push on the plunger in the valve by inserting small screwdriver in the open end (**FIG. 37-2**). If the plunger does not move with a smooth, spring-loaded action (approximately 1/8"), replace the valve cartridge. **Reinstall lowering solenoid valve** (if good) or a replacement. **Torque valve cartridge to 30 lbs.-ft. and hex nut to 30 lbs.-in.**



CHECKING SOLENOID VALVE
FIG. 37-2

**PLATFORM BEGINS TO LOWER ON LH SIDE,
BUT WILL NOT LOWER ON RH SIDE**

1. Check for battery voltage at the hydraulic lock as follows. Disconnect wiring harness from coil on the lock valve (**FIG. 38-1**). Then, connect voltmeter (+) and (-) leads to connector contacts 1 and 2 on the wiring harness (**FIG. 38-2**). Hold control switch in the **DOWN** position just long enough to get a reading. Voltmeter should read at least 11 volts DC. If voltage reading is lower or "0", go to step 4.

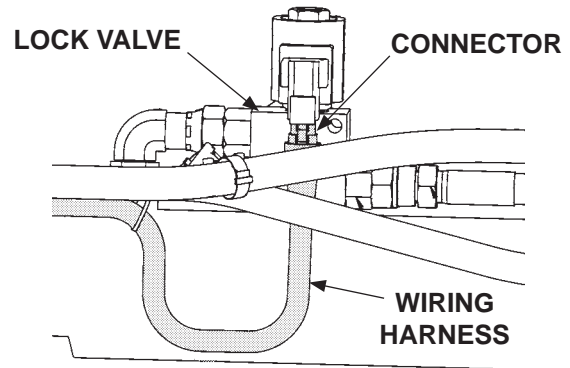

**LOCK VALVE WIRING
HARNESS CONNECTOR
FIG. 38-1**

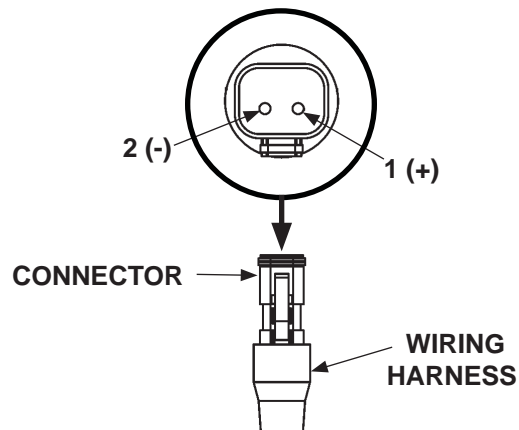

**MEASURING VOLTAGE AT LOCK VALVE
WIRING HARNESS CONNECTOR
FIG. 38-2**

2. Connect ohmmeter (+) and (-) leads to connector contacts 1 and 2 on the coil (**FIG. 38-3**). Ohmmeter should read about 7 to 8 ohms. If ohms reading is higher or lower, replace the coil on hydraulic lock valve.

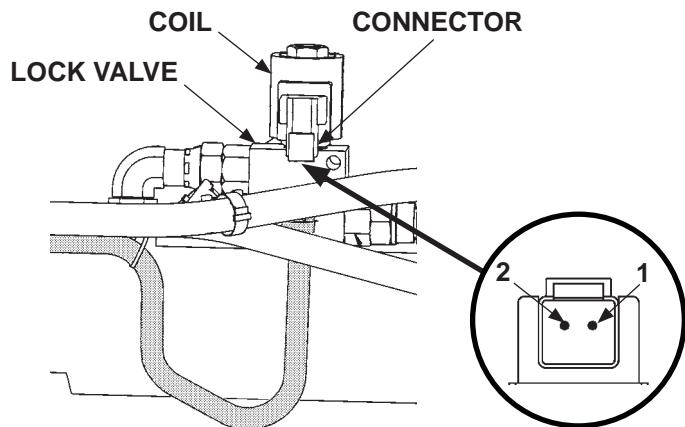

**MEASURING COIL RESISTANCE
FIG. 38-3**

CAUTION

Keep dirt, water and other contaminants from entering the hydraulic system. Before opening the hydraulic fluid reservoir filler cap, drain plug and hydraulic lines, clean up contaminants that can get in the openings. Also, protect the openings from accidental contamination during maintenance.

3. Support the platform to prevent it from dropping. Remove solenoid valve (**FIG. 39-1**). Ensure the valve operates with a smooth spring-loaded action (**FIG. 39-2**). Check for debris inside the valve. If necessary, clean or replace the cartridge valve. Re-install cartridge valve (if good) or install a replacement.

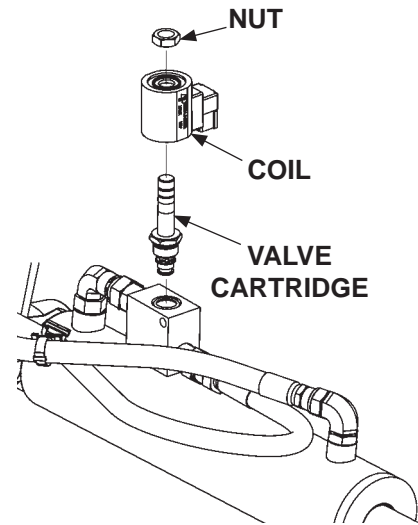

**REMOVING SOLENOID VALVE
FIG. 39-1**

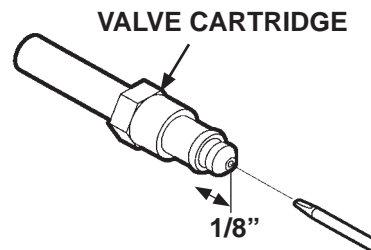

**CHECKING SOLENOID VALVE
FIG. 39-2**

4. Unfasten and remove pump cover (**FIG. 39-3**).

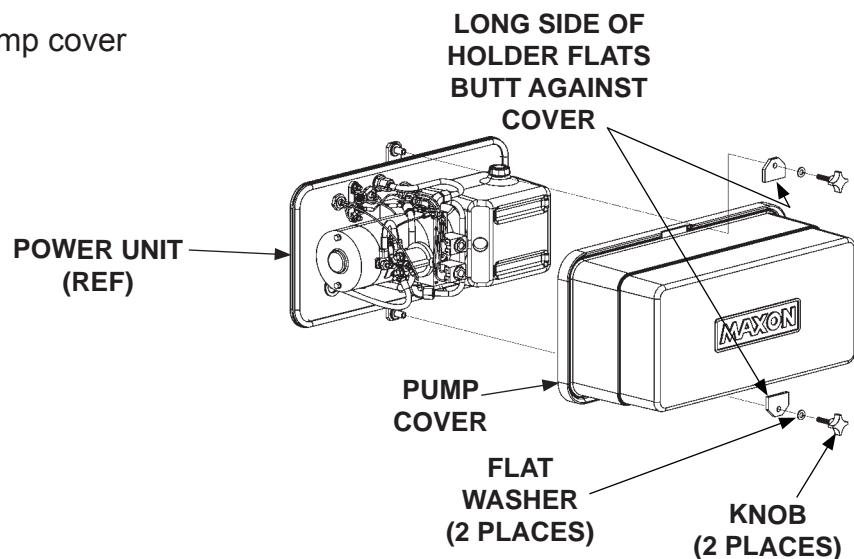

**REMOVING PUMP COVER
FIG. 39-3**

PLATFORM BEGINS TO LOWER ON LH SIDE, BUT WILL NOT LOWER ON RH SIDE - Continued

5. Disconnect white wire from the “S2” (lowering) solenoid valve (FIG. 40-1). Do resistance checks on the lock valve wiring harness as follows.

- Connect ohmmeter (+) and (-) leads to the black wire and contact 1 on the wiring harness connector (FIG. 40-2). Reading should be 0.5 ohm or less.

NOTE: Ensure ground bolt and ground wiring connections on the pump are clean and tight (FIG. 40-1).

- Connect ohmmeter (+) and (-) leads to the white ground wire and contact 2 on the wiring harness connector (FIG. 40-2). Reading should be 0.5 ohm or less.
- If any readings are more than 0.5 ohm, check lock valve wiring harness for crimps or damage. Repair wiring harness if possible, or replace the entire lock valve assembly, if necessary.

6. Before completing this procedure, ensure lock valve wiring is reconnected to “S2” (lowering) solenoid valve, ground bolt, control switch wire, and lock valve coil.

7. Install and fasten pump cover as shown in FIG. 41-2. Hand-tighten the cover knobs.

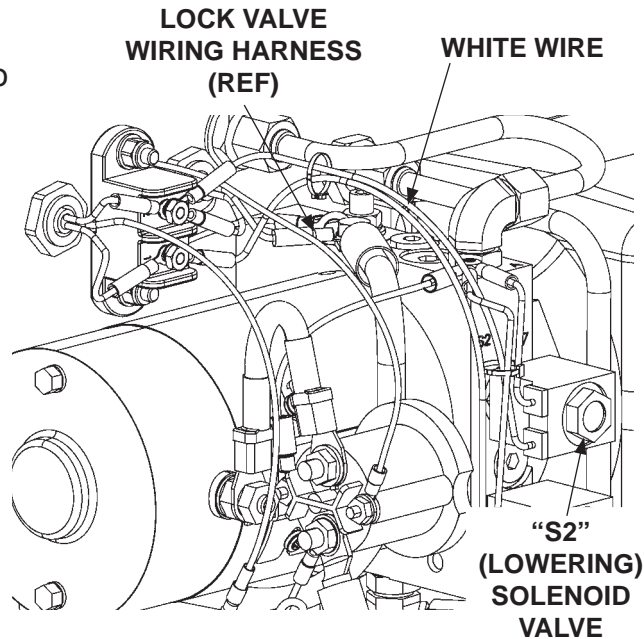

**DISCONNECTING LOCK VALVE WIRING
FROM LOWERING SOLENOID VALVE
FIG. 40-1**

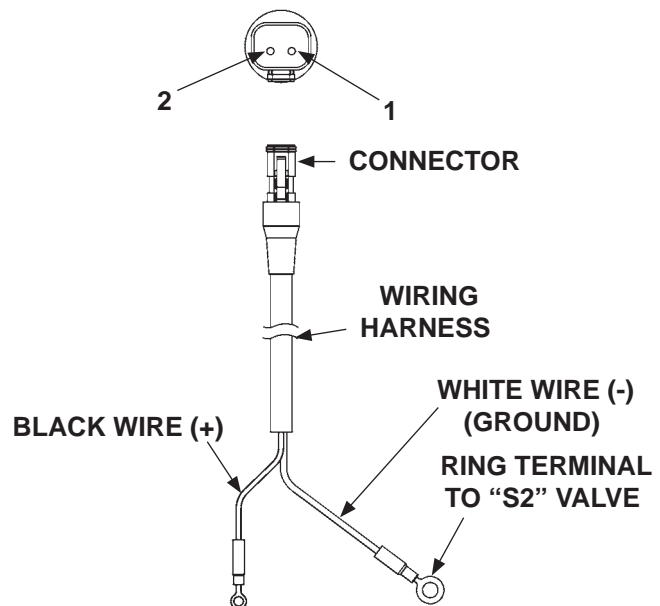

**MEASURING RESISTANCE ON LOCK
VALVE WIRING HARNESS
FIG. 40-2**

PLATFORM WILL NOT TILT DOWN TO THE GROUND

NOTE: If the Liftgate is not damaged, the 1100 psi (lowering) pressure relief valve in the pump may need to be adjusted as follows.

1. Lower the platform until shackles touch the ground (**FIG. 41-1**).

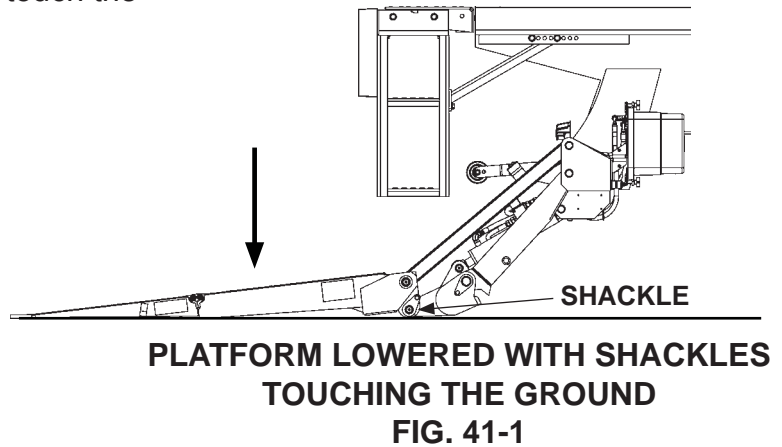

2. Unfasten and remove pump cover (**FIG. 41-2**).

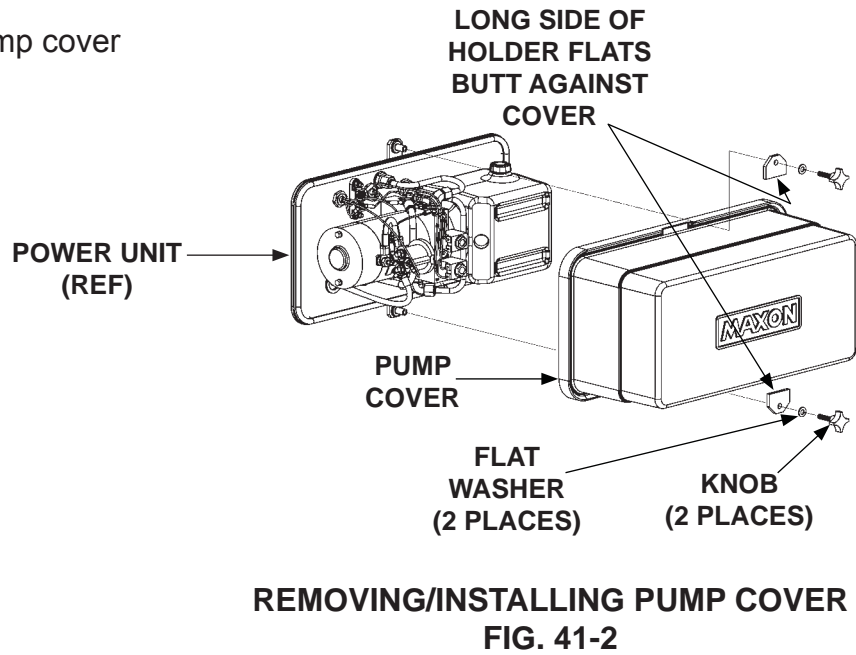

PLATFORM WILL NOT TILT DOWN TO THE GROUND - Continued

CAUTION

Before disconnecting DOWN line, ensure UP line & elbow are connected to port A.

3. Check the 1100 psi relief valve as follows. With platform on the ground, disconnect DOWN line from Port "B" and remove elbow (FIG. 42-1). Install 0-3000 psi pressure gauge in Port "B" (FIG. 42-1). Loosen relief valve lock nut and hold the control switch in the DOWN position. Adjust the relief valve until the gauge reads 1100 psi (FIG. 42-1). Then, tighten relief valve lock nut. Remove gauge and reinstall elbow and DOWN line.

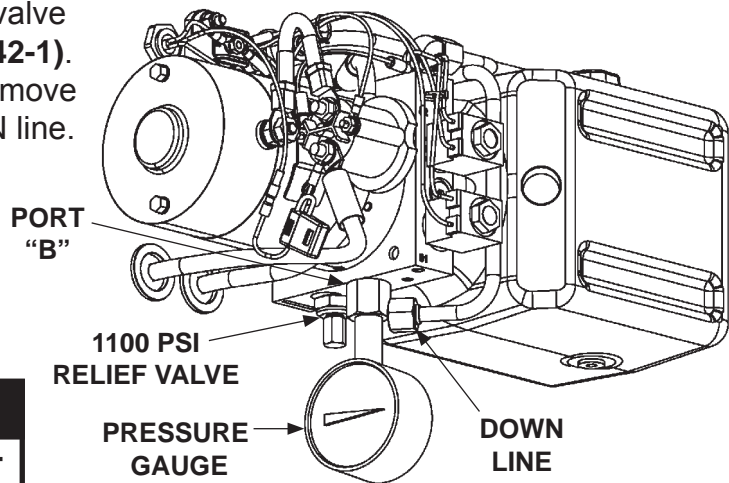

**ADJUSTING RELIEF VALVE
FIG. 42-1**

CAUTION

Pump cover must be correctly secured to prevent it from becoming a hazard. To secure pump cover, the long side of the holder flats must butt against pump cover as shown in the illustration.

4. Install pump cover as shown in FIG. 42-2. Hand-tighten the cover knobs.

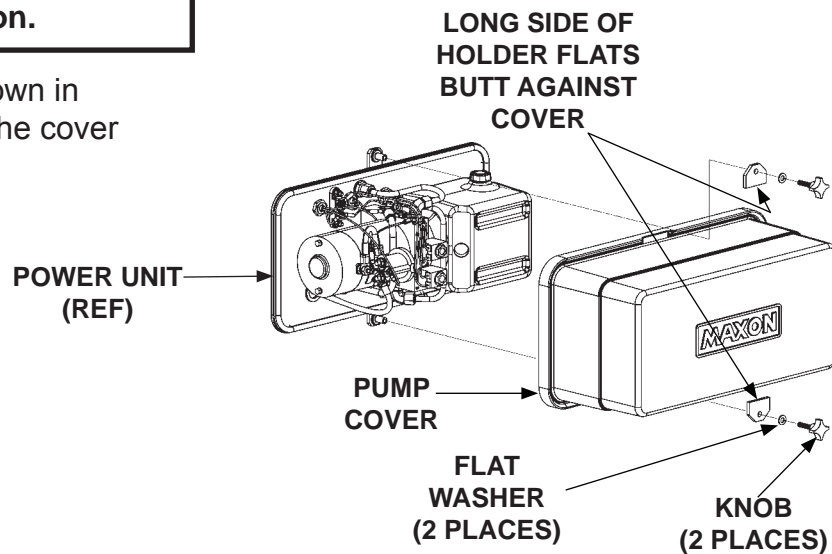

**INSTALLING PUMP COVER
FIG. 42-2**

