

M-17-12
REV. A
JULY 2018

MAXON®

TE-25DC & TE-33

MAINTENANCE MANUAL

TE-25DC & TEWR-25DC
TE-33 & TEWR-33

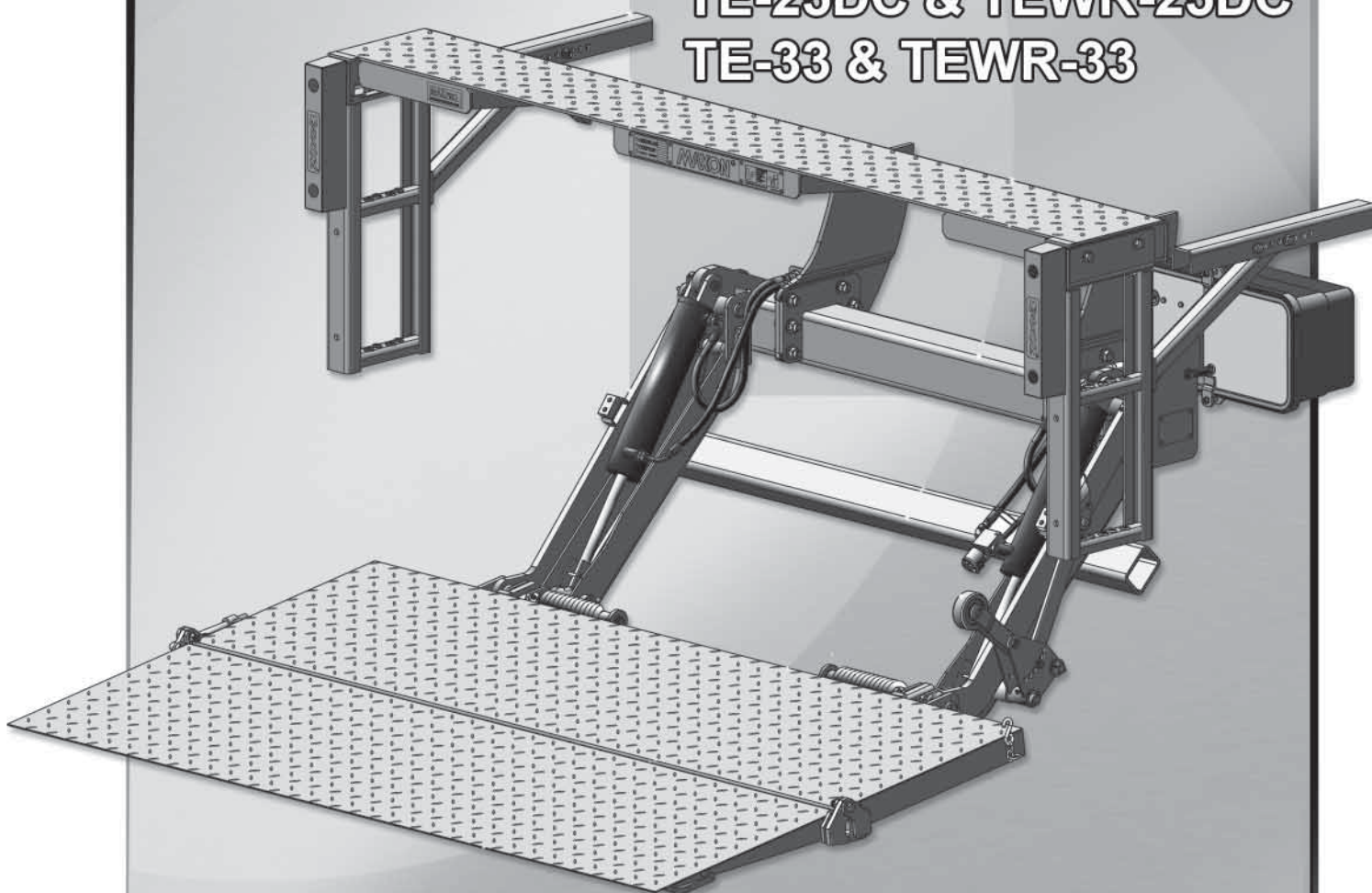

MAXON[®]

LIFT CORP.

11921 Slauson Ave.
Santa Fe Springs, CA. 90670

CUSTOMER SERVICE:

TELEPHONE (562) 464-0099 TOLL FREE (800) 227-4116

FAX: (888) 771-7713

NOTE: For latest version of all Manuals (and replacements), download the Manuals from Maxon's website at www.maxonlift.com.

WARRANTY/ RMA POLICY & PROCEDURE

LIFTGATE WARRANTY

Type of Warranty: Full Parts and Labor

Term of Warranty: Standard Liftgates - 2 years from ship date or 6,000 cycles
Premium Liftgates - 2 years from ship date or 10,000 cycles

This warranty shall not apply unless the product is installed, operated and maintained in accordance with MAXON Lift's specifications as set forth in MAXON Lift's Installation, Operation and Maintenance manuals. This warranty does not cover normal wear, maintenance or adjustments, damage or malfunction caused by improper handling, installation, abuse, misuse, negligence, or carelessness of operation. In addition, this warranty does not cover equipment that has had unauthorized modifications or alterations made to the product.

MAXON agrees to replace any components which are found to be defective during the first 2 years of service, and will reimburse for labor based on MAXON's Liftgate Warranty Flat Rate Schedule. (Copy of the Flat Rate is available at www.maxonlift.com.)

All warranty repairs must be performed by an authorized MAXON warranty facility. For any repairs that may exceed \$500, including parts and labor, MAXON's Technical Service Department must be notified and an "Authorization Number" obtained.

All claims for warranty must be received within 30 Days of the repair date, and include the following information:

1. Liftgate Model Number and Serial Number
2. The End User must be referenced on the claim
3. Detailed Description of Problem
4. Corrective Action Taken, and Date of Repair
5. Parts used for Repair, Including MAXON Part Number(s)
6. MAXON R.M.A. # and/or Authorization # if applicable (see below)
7. Person contacted at MAXON if applicable
8. Claim must show detailed information i.e. Labor rate and hours of work performed

Warranty claims can also be placed online at www.maxonlift.com. Online claims will be given priority processing.

All claims for warranty will be denied if paperwork has not been received or claim submitted via Maxon website for processing by MAXON's Warranty Department within 30 days of repair date.

All components may be subject to return for inspection, prior to the claim being processed. MAXON products may not be returned without prior written approval from MAXON's Technical Service Department. Returns must be accompanied by a copy of the original invoice or reference with original invoice number and are subject to a credit deduction to cover handling charges and any necessary reconditioning costs. **Unauthorized returns will be refused and will become the responsibility of the returnee.**

Any goods being returned to MAXON Lift must be pre-approved for return, and have the R.M.A. number written on the outside of the package in plain view, and returned freight prepaid. All returns are subject to a 15% handling charge if not accompanied by a detailed packing list. Returned parts are subject to no credit and returned back to the customer. Defective parts requested for return must be returned within 30 days of the claim date for consideration to:

MAXON Lift Corp.
10321 Greenleaf Ave., Santa Fe Springs, CA 90670
Attn: RMA# _____

MAXON's warranty policy does not include the reimbursement for travel time, towing, vehicle rental, service calls, oil, batteries or loss of income due to downtime. Fabrication or use of non Maxon parts, which are available from MAXON, are also not covered.

MAXON's Flat Rate Labor Schedule takes into consideration the time required for diagnosis of a problem.

All Liftgates returned are subject to inspection and a 15% restocking fee. Any returned Liftgates or components that have been installed or not returned in new condition will be subject to an additional reworking charge, which will be based upon the labor and material cost required to return the Liftgate or component to new condition.

PURCHASE PART WARRANTY

Term of Warranty: 1 Year from Date of Purchase.

Type of Warranty: Part replacement only. MAXON will guarantee all returned genuine MAXON replacement parts upon receipt and inspection of parts and original invoice.

All warranty replacements parts will be sent out via ground freight. If a rush shipment is requested, all freight charges will be billed to the requesting party.

TABLE OF CONTENTS

SUMMARY OF CHANGES: M-17-12, REVISION A	6
WARNINGS	8
SAFETY INSTRUCTIONS	9
LIFTGATE TERMINOLOGY	10
PERIODIC MAINTENANCE	11
PERIODIC MAINTENANCE CHECKS	11
PERIODIC MAINTENANCE CHECKLIST	12
CHECKING HYDRAULIC FLUID	14
CHANGING HYDRAULIC FLUID	16
REPLACING PLATFORM TORSION SPRING	18
DECALS: TE-25DC & TE-33	22
DECALS & PLATES	24
DECALS: TEWR-25DC & TEWR-33	26
DECALS & PLATES	28
SYSTEM DIAGRAMS	29
PUMP & MOTOR SOLENOID OPERATION (GRAVITY DOWN).....	29
PUMP & MOTOR SOLENOID OPERATION (POWER DOWN).....	30
HYDRAULIC SCHEMATIC (GRAVITY DOWN).....	31
HYDRAULIC SCHEMATIC (POWER DOWN)	32
ELECTRICAL SCHEMATIC (GRAVITY DOWN)	33
ELECTRICAL SCHEMATIC (POWER DOWN)	34
ELECTRICAL VALUES.....	35
TROUBLESHOOTING	36
PLATFORM WILL NOT RAISE & MOTOR WILL NOT RUN	36

PLATFORM WILL NOT RAISE, BUT MOTOR RUNS	37
PLATFORM RAISES BUT LEAKS DOWN	38
PLATFORM RAISES PARTIALLY AND STOPS	40
LIFTGATE WILL NOT LIFT RATED CAPACITY	42
PLATFORM WILL NOT LOWER, LOWERS TOO SLOWLY, OR TOO QUICKLY	44

SUMMARY OF CHANGES: M-17-12, REVISION A

PAGE	DESCRIPTION OF CHANGE
Cover	Updated REV, date of release, and models. TE-25DC & TEWR-25DC were added.
Various	Added TE-25DC and TEWR-25DC throughout the manual with topics & instructions about TE-33 & TEWR-33 liftgates.
11,12	Changed aluminum primer touchup paint kit to generic aluminum primer touchup paint.
22,25	Added new bilingual UP/DOWN decals and removed old UP & DOWN decal.
23,27	Added table for 2500 lb and 3300 lb capacity decals.
35	Updated electrical values table to include cycle counter operation voltage.

THIS PAGE INTENTIONALLY LEFT BLANK

Comply with the following **WARNINGS** and **SAFETY INSTRUCTIONS** while maintaining Liftgates. See Operation Manual for operating safety requirements.

⚠ WARNING

- Do not stand, or allow obstructions, under the platform when lowering the Liftgate. **Be sure your feet are clear of the Liftgate.**
- **Keep fingers, hands, arms, legs, and feet clear of moving Liftgate parts (and platform edges) when operating the Liftgate.**
- **Correctly stow platform when not in use. Extended platforms could create a hazard for people and vehicles passing by.**
- **Disconnect Liftgate power cable from battery** before repairing or servicing Liftgate.
- If it is necessary to stand on the platform while maintaining the Liftgate, keep your feet and any objects clear of the inboard edge of the platform. Your feet or objects on the platform can become trapped between the platform and the Liftgate extension plate.
- Recommended practices for welding on steel parts are contained in the current **AWS (American Welding Society) D1.1 Structural Welding Code - Steel**. Damage to Liftgate and/or vehicle, and personal injury could result from welds that are done incorrectly.
- Recommended practices for welding on aluminum parts are contained in the current **AWS (American Welding Society) D1.2 Structural Welding Code - Aluminum**. Damage to Liftgate and/or vehicle, and personal injury could result from welds that are done incorrectly.
- Recommended practices for welding galvanized steel are contained in the current **AWS (American Welding Society) D19.0 Welding Zinc-Coated Steel**. Damage to Liftgate and/or vehicle, and personal injury can result from welds that are done incorrectly.

MAXON[®]

11921 Slauson Ave. Santa Fe Springs, CA. 90670 (800) 227-4116 FAX (888) 771-7713

SAFETY INSTRUCTIONS

- Read and understand the instructions in this **Maintenance Manual** before performing maintenance on the Liftgate.
- Before operating the Liftgate, read and understand the operating instructions in **Operation Manual**.
- Comply with all **WARNING** and instruction decals attached to the Liftgate.
- Keep decals clean and legible. If decals are illegible or missing, replace them. Free replacement decals are available from **Maxon Customer Service**.
- Consider the safety and location of bystanders and location of nearby objects when operating the Liftgate. Stand to one side of the platform while operating the Liftgate.
- Do not allow untrained persons to operate the Liftgate.
- Wear appropriate safety equipment such as protective eyeglasses, faceshield and clothing while performing maintenance on the Liftgate and handling the battery. Debris from drilling and contact with battery acid may injure unprotected eyes and skin.
- Be careful working by an automotive type battery. Make sure the work area is well ventilated and there are no flames or sparks near the battery. Never lay objects on the battery that can short the terminals together. If battery acid gets in your eyes, immediately seek first aid. If acid gets on your skin, immediately wash it off with soap and water.
- If an emergency situation arises (vehicle or Liftgate) while operating the Liftgate, release the control switch to stop the Liftgate.
- A correctly installed Liftgate operates smoothly and reasonably quiet. The only noticeable noise during operation comes from the power unit while the platform is raised. Listen for scraping, grating and binding noises and correct the problem before continuing to operate Liftgate.
- Use only **Maxon Authorized Parts** for replacement parts. Provide Liftgate model and serial number information with your parts order. Order replacement parts from:

MAXON LIFT CORP. Customer Service
11921 Slauson Ave., Santa Fe Springs, CA 90670

Online: www.maxonlift.com

Express Parts Ordering: Phone (800) 227-4116 ext. 4345

Email: Ask your Customer Service representative

LIFTGATE TERMINOLOGY

MAXON[®]

11921 Slauson Ave. Santa Fe Springs, CA. 90670 (800) 227-4116 FAX (888) 771-7713

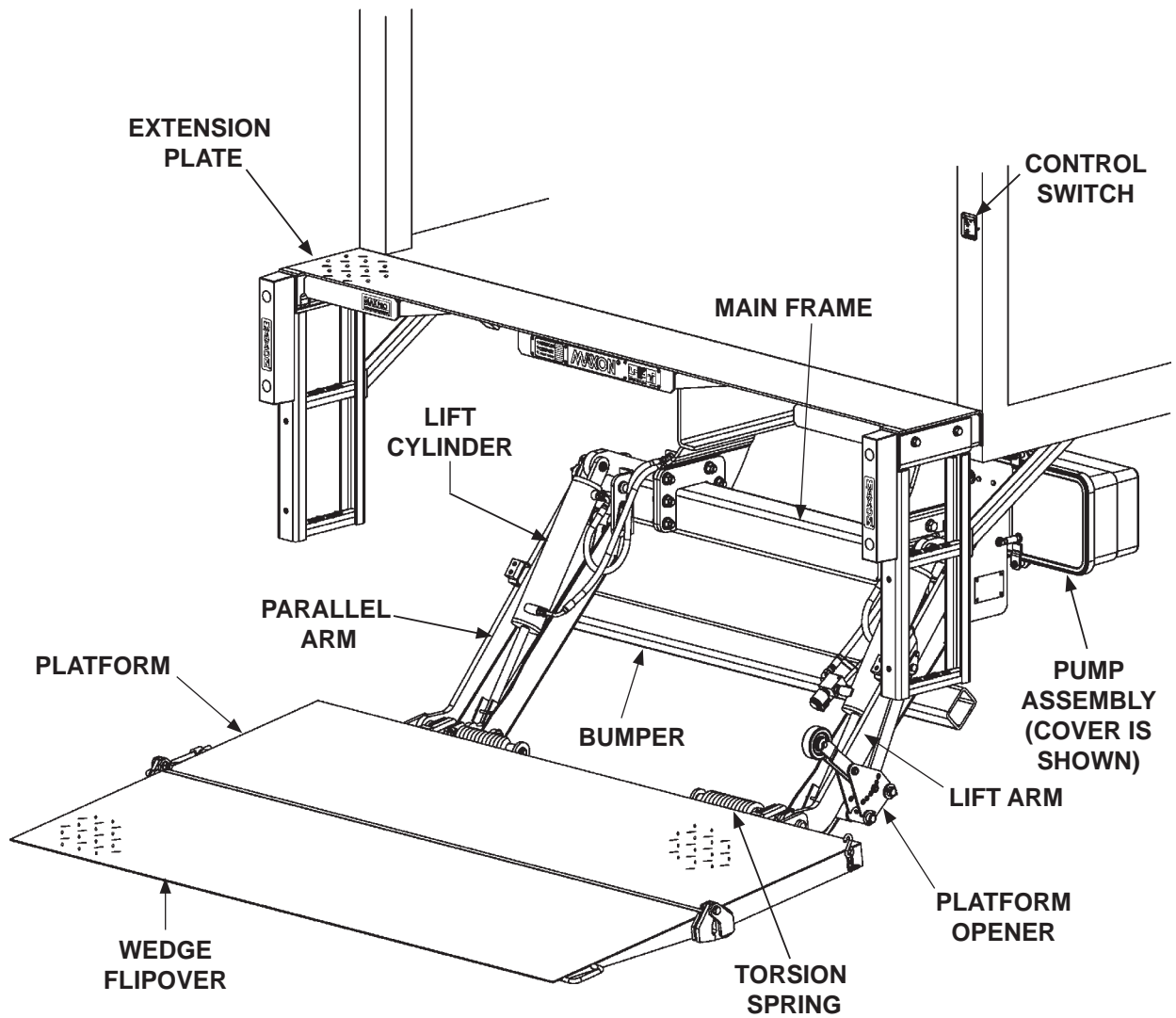

PERIODIC MAINTENANCE PERIODIC MAINTENANCE CHECKS

⚠ WARNING

Never operate the Liftgate if parts are loose or missing.

NOTE: Make sure vehicle is parked on level ground while performing the maintenance checks.

Quarterly or 1250 Cycles (whichever occurs first)

Check the hydraulic fluid level in the pump reservoir. Refer to the **CHECKING HYDRAULIC FLUID** procedure in the **PERIODIC MAINTENANCE** section.

If hydraulic fluid appears contaminated, refer to the **CHANGING HYDRAULIC FLUID** procedure in the **PERIODIC MAINTENANCE** section.

Keep track of the grade of hydraulic fluid in the pump reservoir and never mix two different grades of fluid.

Check all hoses and fittings for chafing and fluid leaks. Tighten loose fittings or replace parts as required.

Check electrical wiring for chafing and make sure wiring connections are tight and free of corrosion. Use dielectric grease to protect electrical connections.

Check that all **WARNING and instruction decals** are in place. Also, make sure decals are legible, clean and undamaged.

Check that all bolts, nuts, and roll pins are in place. Make sure roll pins protrude evenly from both sides of hinge pin collar. Replace fasteners and roll pins if necessary.

Pump EP chassis grease in each lube fitting on the cylinders and arms until grease starts oozing from ends of the bearings. The lubrication diagram on the **PERIODIC MAINTENANCE CHECKLIST SHEET** shows where to find the lube fittings. Wipe off excess grease with a clean lint-free cloth.

CAUTION

Damaged cylinder seals and contaminated hydraulic fluid can result from painting the polished portion of the cylinder rod. To prevent damage, protect the exposed polished portion of the cylinder rod while painting.

Check for rust and oily surfaces on Liftgate. If there is rust or oil on Liftgate, clean it off. Touch up the paint where bare metal is showing. MAXON recommends using aluminum primer touchup paint.

Semi-annually or 2500 Cycles (whichever occurs first)

Visually check the platform hinge pins for excessive wear and broken welds. See **PARTS BREAKDOWN** section for replacement parts. Also, do the **Quarterly or 1250 Cycles** maintenance checks.

PERIODIC MAINTENANCE CHECKLIST

NOTE: Make sure vehicle is parked on level ground while performing maintenance checks.

Quarterly or 1250 Cycles (whichever occurs first)

- Check the level and condition of the hydraulic fluid.
- Visually check all hoses and fittings for chafing and fluid leaks. Tighten loose fittings or replace parts as required.
- Check electrical wiring for chafing and make sure wiring connections are tight and free of corrosion. Use dielectric grease to protect electrical connections.
- Check that all **WARNING and instruction decals** are in place. Also, make sure decals are legible, clean, and undamaged.
- Check that all bolts, nuts, and roll pins are in place. Make sure roll pins protrude evenly from both sides of hinge pin collar. Replace fasteners and roll pins if necessary.
- Check for rust and oily surfaces on Liftgate. If there is rust or oil on Liftgate or if the Liftgate is dirty, clean it off. Touch up the paint where bare metal is showing. Refer to the paint system **CAUTION** and recommended touchup paint on the preceding page.
- Pump EP chassis grease in each lube fitting on the cylinders and arms until grease starts oozing from ends of the bearings. Refer to lubrication diagram on the next page. Wipe off excess grease with a clean lint-free cloth.

Semi-annually or 2500 Cycles (whichever occurs first)

- Visually check the platform hinge pins for excessive wear and broken welds.
- Do the **Quarterly or 1250 Cycles Checks** on this checklist.

Before every use

- Visually check the the trailer hitch for excessive wear and damage. Ensure that the hitch pin hole is not elongated, that the clevis pin is in place, and that the clevis pin attachment wire is connected.

MAXON[®]

11921 Slauson Ave. Santa Fe Springs, CA. 90670 (800) 227-4116 FAX (888) 771-7713

PERIODIC MAINTENANCE CHECKLIST

NOTE: Lube fittings are shown for the RH cylinder, lift arm, parallel arm, and opener. There are also lube fittings at the same places on the LH cylinder, lift arm, and parallel arm. Refer to the **PERIODIC MAINTENANCE CHECKS** and **PERIODIC MAINTENANCE CHECKLIST** for the recommended grease and maintenance interval.

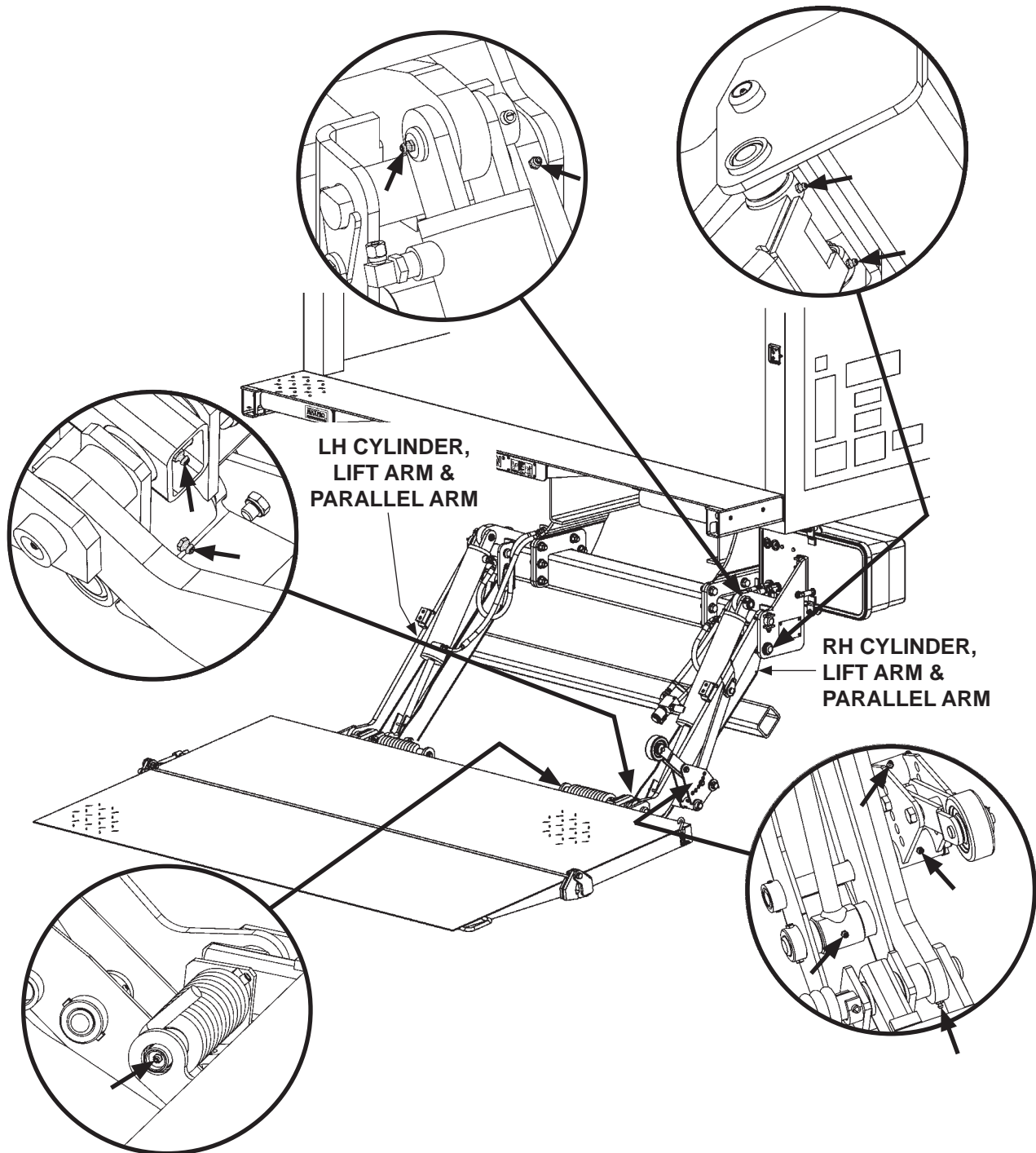

TE-25DC & TE-33 LUBRICATION DIAGRAM
FIG. 13-1

PERIODIC MAINTENANCE

CHECKING HYDRAULIC FLUID

CAUTION

Keep dirt, water and other contaminants from entering the hydraulic system. Before opening the hydraulic fluid reservoir filler cap, drain plug and hydraulic lines, clean up contaminants that can get in the openings. Also, protect the openings from accidental contamination.

NOTE: Use correct grade of hydraulic fluid for your location.

+50 to +120 Degrees F - Grade ISO 32

Below + 70 Degrees F - Grade ISO 15 or MIL-H-5606

See **TABLES 15-1 & 15-2** for recommended brands.

1. Unbolt and remove pump cover (FIG. 14-1).
2. Check the hydraulic fluid level in reservoir as follows. With Liftgate stowed, or platform at vehicle bed height, level should be as shown in FIG. 14-2.

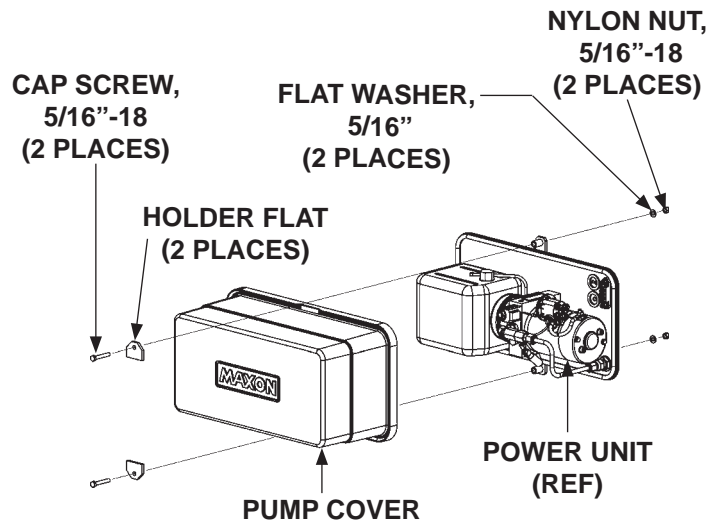

UNBOLTING/BOLTING PUMP COVER
FIG. 14-1

3. If needed, add fluid to the reservoir as follows. Pull out (no threads) filler cap (FIG. 14-2). Fill the reservoir with hydraulic fluid to level shown in FIG. 14-2. Reinstall filler cap (FIG. 14-2).

CAUTION

Pump cover must be correctly secured to prevent it from becoming a hazard. To secure pump cover, the long side of the holder flats must butt against pump cover as shown in the illustration.

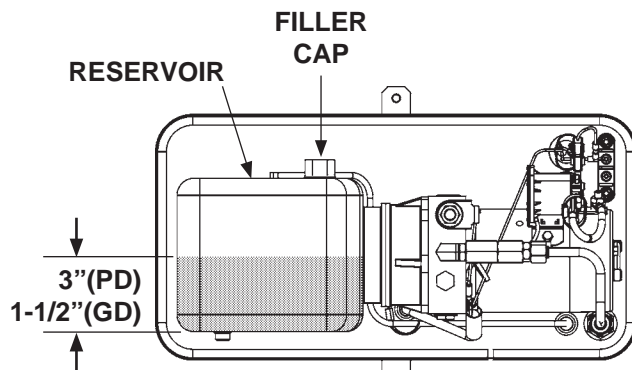

POWER UNIT FLUID LEVEL
FIG. 14-2

4. Bolt on the pump cover as shown in FIG. 14-1. Torque the bolts (cap screws) to **10-14 lb-in.**

MAXON[®]

11921 Slauson Ave. Santa Fe Springs, CA. 90670 (800) 227-4116 FAX (888) 771-7713

ISO 32 HYDRAULIC OIL	
RECOMMENDED BRANDS	PART NUMBER
CHEVRON	HIPERSYN 32
KENDALL	GOLDEN MV
SHELL	TELLUS S2 VX 32
EXXONMOBIL	UNIVIS N-32, DTE-24

TABLE 15-1

ISO 15 OR MIL-H-5606 HYDRAULIC OIL	
RECOMMENDED BRANDS	PART NUMBER
CHEVRON	FLUID A, AW-MV-15
KENDALL	GLACIAL BLU
SHELL	TELLUS S2 VX 15
EXXONMOBIL	UNIVIS HVI-13
ROSEMEAD	THS FLUID 17111

TABLE 15-2

PERIODIC MAINTENANCE CHANGING HYDRAULIC FLUID

CAUTION

Keep dirt, water and other contaminants from entering the hydraulic system. Before opening the hydraulic fluid reservoir filler cap, drain plug and hydraulic lines, clean up contaminants that can get in the openings. Also, protect the openings from accidental contamination.

NOTE: Use correct grade of hydraulic fluid for your location.

+50 to +120 Degrees F - Grade ISO 32

Below + 70 Degrees F - Grade ISO 15 or MIL-H-5606

See **TABLES 15-1 & 15-2** for recommended brands.

1. Unbolt and remove pump cover (FIG. 16-1). Place empty 5 gallon bucket under drain plug (FIG. 16-2).

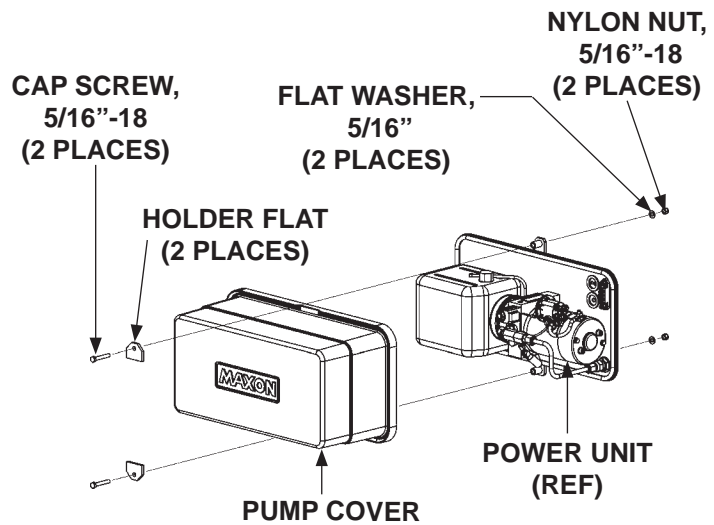

**UNBOLTING PUMP COVER
FIG. 16-1**

2. Open and raise platform to vehicle bed height. Pull out (no threads) drain plug (FIG. 16-2). Drain hydraulic fluid.

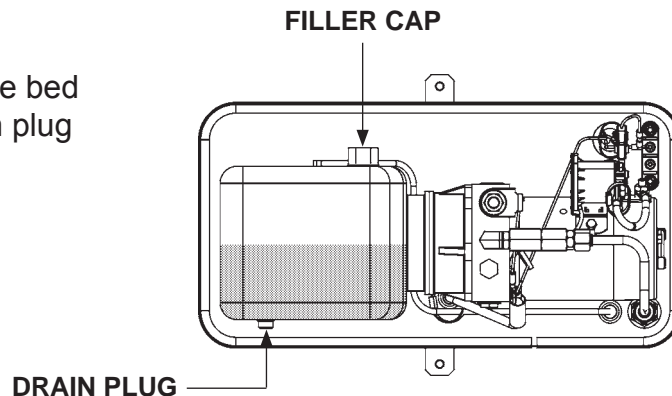

**POWER UNIT
FIG. 16-2**

MAXON[®]

11921 Slauson Ave. Santa Fe Springs, CA. 90670 (800) 227-4116 FAX (888) 771-7713

3. Lower the platform all the way to the ground while draining the remaining hydraulic fluid.
4. Reinstall drain plug (**FIG. 16-2**).
5. Pull out (no threads) filler cap (**FIG. 16-2**). Add 1 gallon of hydraulic fluid to reservoir. Re-install filler cap.
6. Stow the Lift and do the **CHECKING HYDRAULIC FLUID** procedure in this section of the manual.

CAUTION

Pump cover must be correctly secured to prevent it from becoming a hazard. To secure pump cover, the long side of the holder flats must butt against pump cover as shown in the illustration.

7. Bolt on the pump cover as shown in **FIG. 17-1**. Torque the 5/16"-18 cover bolts from **10 to 14 lb-in.**

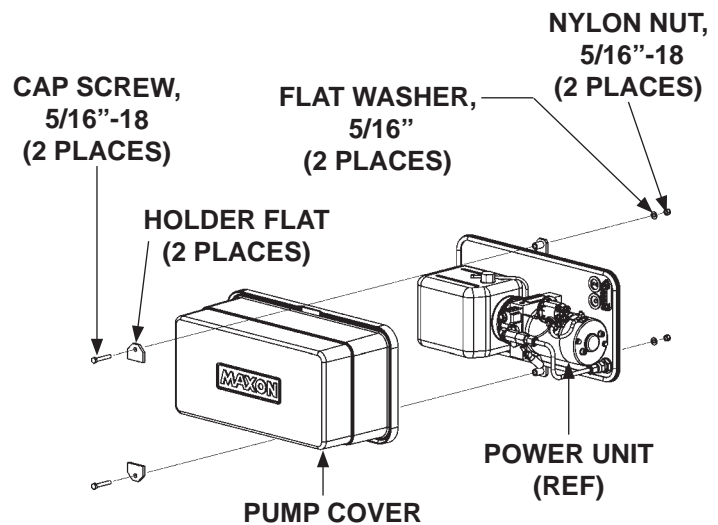

BOLTING ON PUMP COVER
FIG. 17-1

PERIODIC MAINTENANCE

REPLACING PLATFORM TORSION SPRING

NOTE: The following procedure shows how to replace torsion spring on RH side of platform. Use this procedure for replacing torsion spring on the LH side.

1. If platform is on the ground, manually fold flipover onto platform.
2. Fold platform and flipover to rest on lift arms (**FIG. 18-1**).
3. Raise platform to a convenient work height to gain access (**FIG. 18-1**). There should not be tension on the torsion spring in this position.

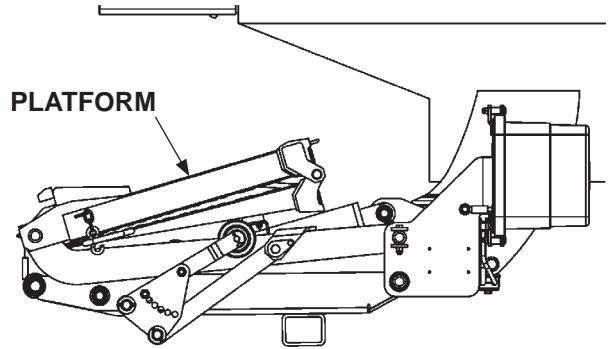
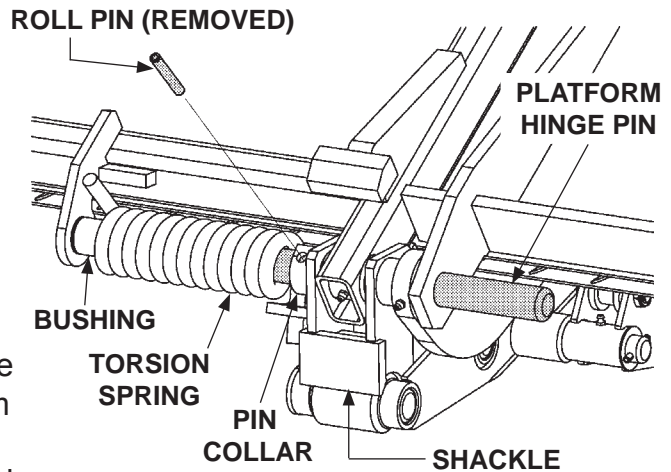

FIG. 18-1

⚠ CAUTION

To prevent injury and equipment damage, make sure there is no tension on torsion spring before removing hinge pin.

4. Drive out the roll pin from pin collar on the platform hinge bracket. Drive the platform hinge pin outboard from the shackle just enough to free the torsion spring and bushing (**FIG. 18-2**). Remove torsion spring.
5. Install the new torsion spring and bushing as shown in (**FIG. 18-3**). Make sure the long leg of the spring is inserted in the bracket located on the shackle.



**REMOVING HINGE PIN
(RH SIDE OF PLATFORM SHOWN)
FIG. 18-2**

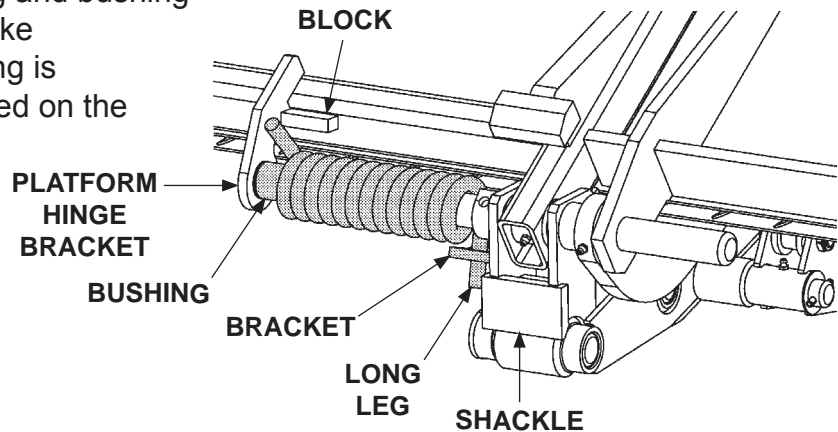

**INSTALLING HINGE PIN
(RH SIDE OF PLATFORM SHOWN)
FIG. 18-3**

6. Drive platform hinge pin inboard to correct position through the platform hinge bracket (**FIG. 19-1**). Line up the hole in the platform hinge pin with the hole in the pin collar. Install the roll pin through the pin collar until roll pin protrudes equally from both sides of the collar (**FIG. 19-1**).
7. Operate the Liftgate according to instructions in **Operation Manual** to make sure it operates correctly.

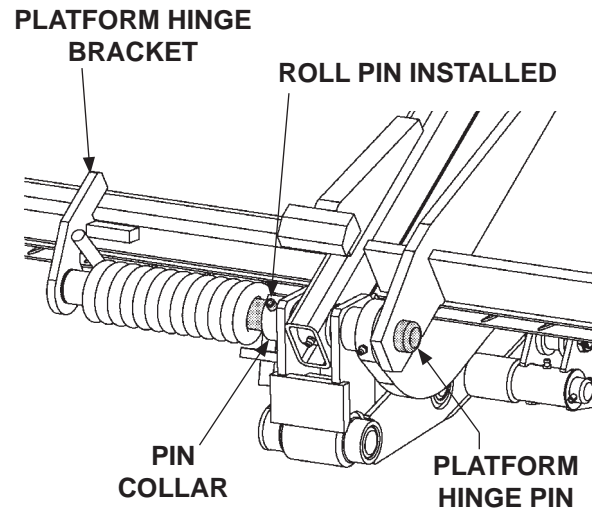

FIG. 19-1

PERIODIC MAINTENANCE PLATFORM ADJUSTMENT

NOTE: Before doing the following procedure, make sure vehicle is parked on level ground.

1. Make sure platform is at ground level. Unfold the platform and flipover. As the platform first touches the ground, shackles and tip of flipover must touch the ground at the same time (**FIG. 20-1**). If shackles and tip of flipover touch the ground at the same time, **RAISE** platform to bed height. Tip of flipover should be above bed level (**FIG. 20-2**). If indications are correct in both cases (**FIGS. 20-1 & 20-2**), Liftgate is installed correctly and no adjustment is needed. If indications are incorrect, continue with instruction 2.

NOTE: If tip of flipover touches first (**FIG. 20-3**), do instruction 2. If the shackle touches first (**FIG. 21-1**), skip instruction 2 and do 3.

2. Make sure platform is still at ground level. If the shackle is not touching the ground, measure and compare distance "A" (**FIG. 20-3**) with **TABLE 20-1** to determine the correct shim. Make shims as needed (**FIG. 20-5**). Weld shim as shown in **FIG. 20-4**.

RAISE TIP OF FLIPOVER THIS DISTANCE "A"	REQUIRED SHIM THICKNESS	WELD SIZE "W"
7/8"	1/16"	1/16"
2"	1/8"	1/8"
3"	3/16"	3/16"
3-15/16"	1/4"	1/4"

TABLE 20-1

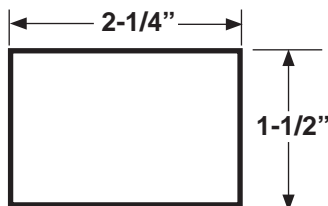

**SHIM MADE FROM STEEL FLAT
FIG. 20-5**

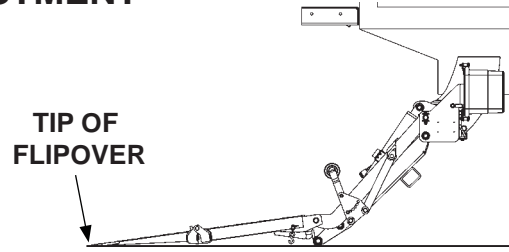

**PLATFORM & SHACKLES
TOUCH GROUND
FIG. 20-1**

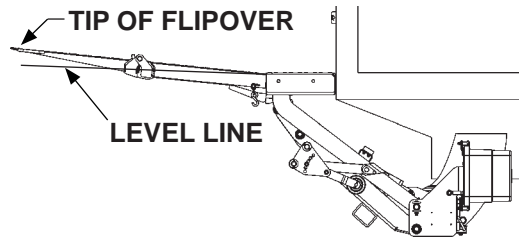

**PLATFORM EDGE ABOVE
BED LEVEL
FIG. 20-2**

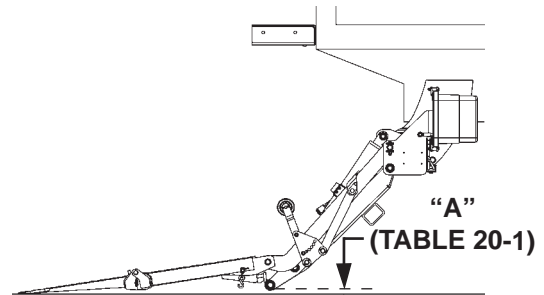

**SHACKLES DO NOT TOUCH
GROUND
FIG. 20-3**

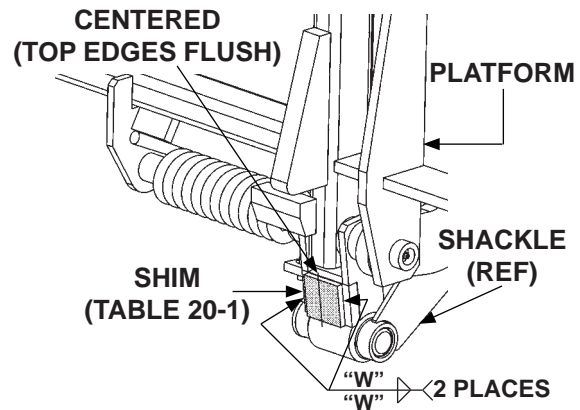

**(TABLE 20-1)
WELDING SHIMS (CURBSIDE SHOWN)
FIG. 20-4**

3. Make sure platform is still at ground level. If the tip of flipover is not touching the ground, measure and compare distance “B” (FIG. 21-1) with TABLE 21-1 to determine how much to grind from the platform stops (FIG. 21-3). Grind correct amount of metal (TABLE 21-1) from platform stop as shown in FIG. 21-3.

LOWER TIP OF FLIPOVER THIS DISTANCE “B”	GRIND METAL FROM PLATFORM STOP
7/8”	1/16”
2”	1/8”
3”	3/16”
3-15/16”	1/4”

TABLE 21-1

4. RAISE the platform to comfortable work height. Fold flipover and platform for access to platform stops (FIG. 21-2).

5. Grind correct amount of metal (TABLE 21-1) from platform stop as shown in FIG. 21-3.

6. Unfold flipover and platform. LOWER platform to the ground. As the platform first touches the ground, the tip of flipover and shackle should touch at the same time as shown in FIG. 20-1.

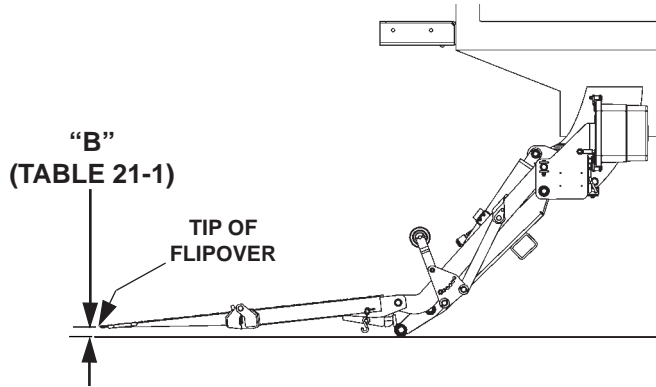

PLATFORM DOES NOT TOUCH GROUND
FIG. 21-1

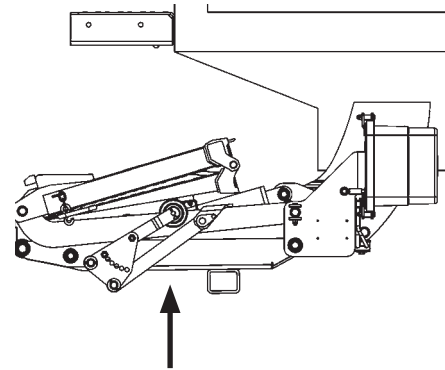

PLATFORM RAISED TO WORK HEIGHT
FIG. 21-2

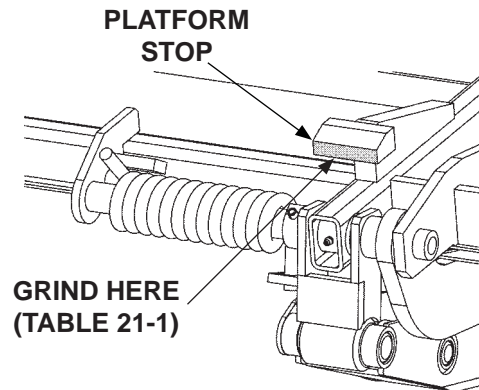

GRINDING PLATFORM STOPS
(CURBSIDE SHOWN)
FIG. 21-3

DECALS: TE-25DC & TE-33

NOTE: Ensure there is no residue, dirt or corrosion where decals are attached.
If necessary, clean surface before attaching decals.

MAXON[®]

11921 Slauson Ave. Santa Fe Springs, CA. 90670 (800) 227-4116 FAX (888) 771-7713

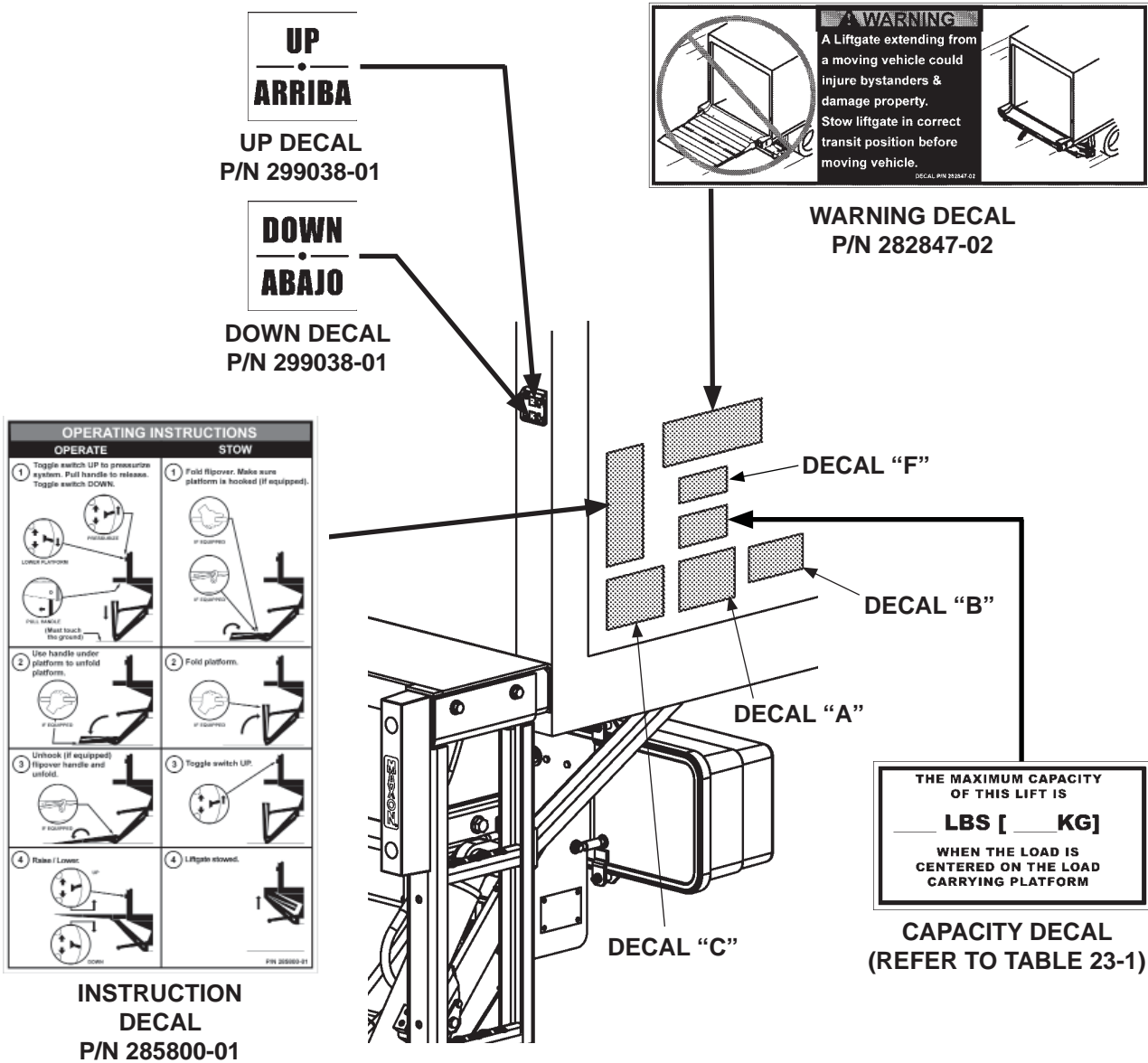

FIG. 22-1

SAFETY INSTRUCTIONS

Read all decals and operation manual before operating liftgate.

1. Do not use liftgate unless you have been properly instructed and have read, and are familiar with, the operating instructions.
2. Be certain vehicle is properly and securely braked before using the liftgate.
3. Always inspect this liftgate for maintenance or damage before using it. Do not use liftgate if it shows any sign of damage or improper maintenance.
4. Do not overload
5. Make certain the area in which the platform will open and close is clear before opening or closing the platform.
6. Make certain platform area, including the area in which loads may fall from platform, is clear before and at all times during operation of liftgate.
7. This liftgate is intended for loading and unloading of cargo only. Do not use this liftgate for anything but its intended use.

A

WARNING

Read this information carefully.

- Improper operation of this Liftgate can result in serious personal injury. If you do not have a copy of the operating instructions, please obtain them from your employer, distributor, or lessor before you attempt to operate Liftgate.
- If there are signs of improper maintenance, damage to vital parts, or slippery platform surface, do not use the Liftgate until these problems have been corrected.
- If you are using a pallet jack, be sure it can be maneuvered safely.
- Do not operate a forklift on the platform.
- Do not allow any part of yours or your helper's body to be placed under, within, or around any portion of the moving Liftgate, or its mechanisms, or in a position that would trap them between the platform and the ground or truck when the Liftgate is operated.
- If a helper is riding the platform with you, make sure you are both doing so safely and that you are not in danger of coming in contact with any moving or potentially moving obstacles.
- **USE GOOD COMMON SENSE.**
- If load appears to be unsafe, do not lift or lower it.

For a free copy of other manuals that pertain to this model Liftgate, please visit our website at www.maxonlift.com or call Customer Service at (800) 227-4116.

C



WARNING

Liftgate hazards can result in crushing or falling.

Keep hands and feet clear of pinch points.

If riding liftgate, make sure load is stable and footing is solid.

P/N 282522-01 **B**

Read and understand all instructions and WARNINGS before use.

CAUTION

Always stand clear of platform area.

F

**DECAL SHEET
P/N 282522-01
FIG. 23-1**

MODEL	DECAL P/N	CAPACITY
TE-25DC	220382	2500 POUNDS [1134 KG]
TE-33	220388-02	3300 POUNDS [1500 KG]

**CAPACITY DECALS
TABLE 23-1**

DECALS & PLATES

MAXON[®]

11921 Slauson Ave. Santa Fe Springs, CA. 90670 (800) 227-4116 FAX (888) 771-7713



**PAINT DECAL
(PAINTED ONLY)
P/N 267338-01**



**MAXON NAME PLATE
P/N 280004-01**

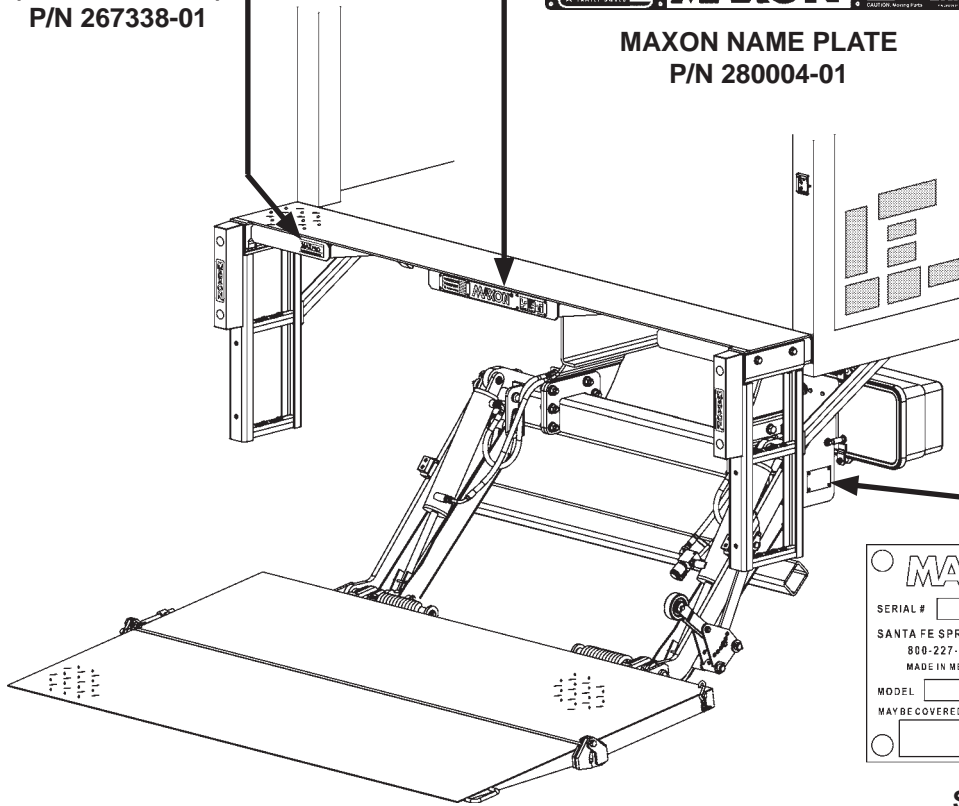

MAXON[®] TUK-A-WAY[®]		LIFT GATE SERIES	
SERIAL #	<input type="text"/>		
SANTA FE SPRINGS, CA	<input type="text"/>		
800-227-4116	<input type="text"/>		
MADE IN MEXICO	SER. PLATE 906246-2	<input type="text"/>	
MODEL <input type="text"/>	CAPACITY <input type="text"/>	LBS.	
MAY BE COVERED BY ONE OR MORE OF THE FOLLOWING PATENTS:			
<input type="text"/>			

**SERIAL PLATE
(REF)**

FIG. 24-1

THIS PAGE INTENTIONALLY LEFT BLANK

DECALS: TEWR-25DC & TEWR-33

NOTE: Ensure there is no residue, dirt or corrosion where decals are attached.
If necessary, clean surface before attaching decals.

MAXON[®]

11921 Slauson Ave. Santa Fe Springs, CA. 90670 (800) 227-4116 FAX (888) 771-7713

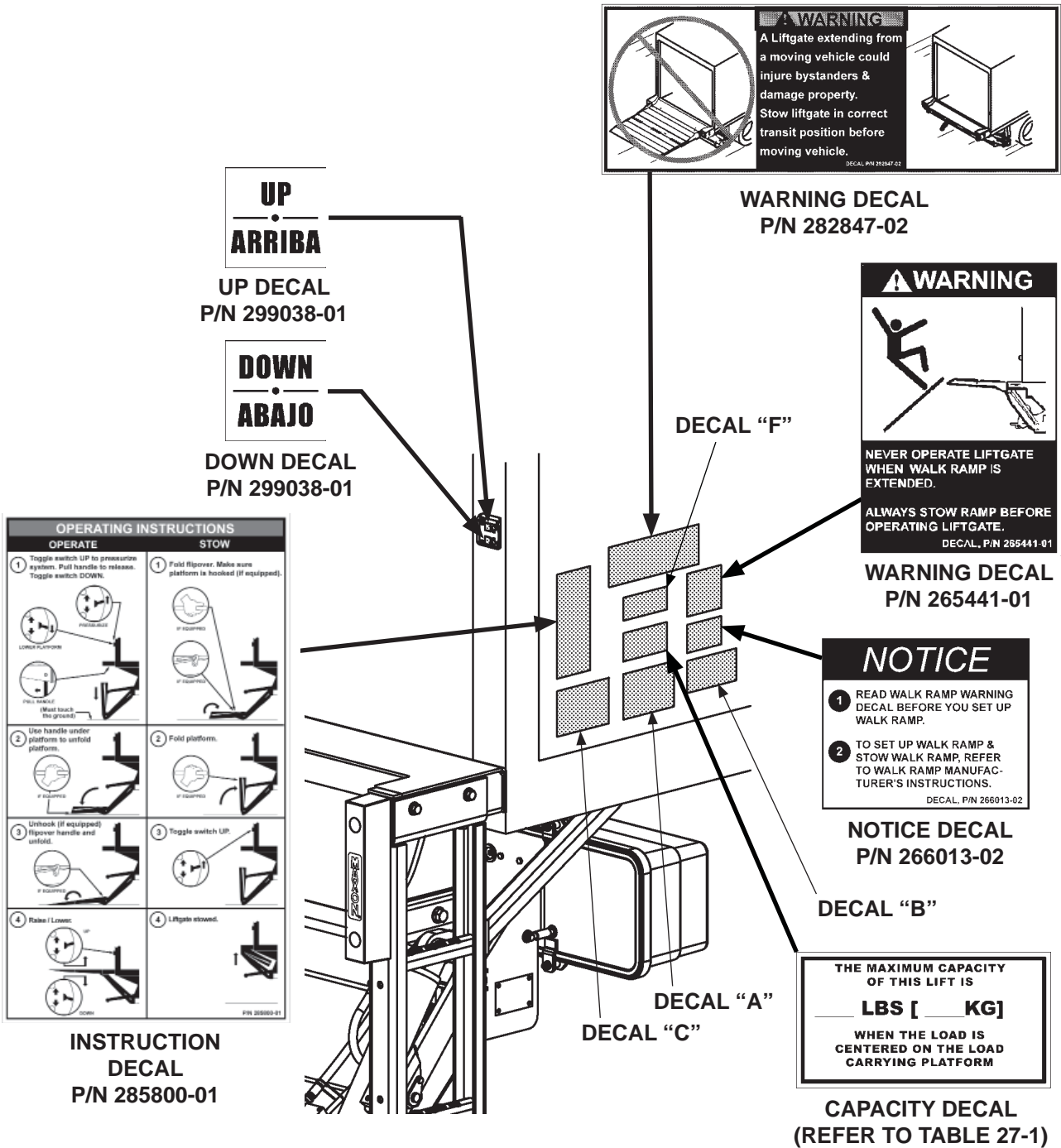

FIG. 26-1

SAFETY INSTRUCTIONS

Read all decals and operation manual before operating liftgate.

1. Do not use liftgate unless you have been properly instructed and have read, and are familiar with, the operating instructions.
2. Be certain vehicle is properly and securely braked before using the liftgate.
3. Always inspect this liftgate for maintenance or damage before using it. Do not use liftgate if it shows any sign of damage or improper maintenance.
4. Do not overload
5. Make certain the area in which the platform will open and close is clear before opening or closing the platform.
6. Make certain platform area, including the area in which loads may fall from platform, is clear before and at all times during operation of liftgate.
7. This liftgate is intended for loading and unloading of cargo only. Do not use this liftgate for anything but its intended use.

(A)

WARNING

Read this information carefully.

- Improper operation of this Liftgate can result in serious personal injury. If you do not have a copy of the operating instructions, please obtain them from your employer, distributor, or lessor before you attempt to operate Liftgate.
- If there are signs of improper maintenance, damage to vital parts, or slippery platform surface, do not use the Liftgate until these problems have been corrected.
- If you are using a pallet jack, be sure it can be maneuvered safely.
- Do not operate a forklift on the platform.
- Do not allow any part of yours or your helper's body to be placed under, within, or around any portion of the moving Liftgate, or its mechanisms, or in a position that would trap them between the platform and the ground or truck when the Liftgate is operated.
- If a helper is riding the platform with you, make sure you are both doing so safely and that you are not in danger of coming in contact with any moving or potentially moving obstacles.
- **USE GOOD COMMON SENSE.**
- If load appears to be unsafe, do not lift or lower it.

For a free copy of other manuals that pertain to this model Liftgate, please visit our website at www.maxonlift.com or call Customer Service at (800) 227-4116.

(C)



WARNING

Liftgate hazards can result in crushing or falling.

Keep hands and feet clear of pinch points.

If riding liftgate, make sure load is stable and footing is solid.

P/N 282522-01 (B)

Read and understand all instructions and WARNINGS before use.

CAUTION

Always stand clear of platform area.

(F)

**DECAL SHEET
P/N 282522-01
FIG. 27-1**

MODEL	DECAL P/N	CAPACITY
TEWR-25DC	220382	2500 POUNDS [1134 KG]
TEWR-33	220388-02	3300 POUNDS [1500 KG]

**CAPACITY DECALS
TABLE 27-1**

DECALS & PLATES

MAXON[®]

11921 Slauson Ave. Santa Fe Springs, CA. 90670 (800) 227-4116 FAX (888) 771-7713



**PAINT DECAL
(PAINTED ONLY)
P/N 267338-01**



**MAXON NAME PLATE
P/N 280004-01**

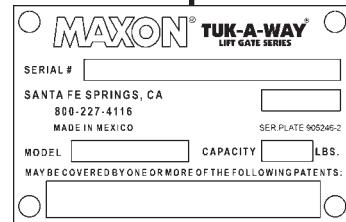
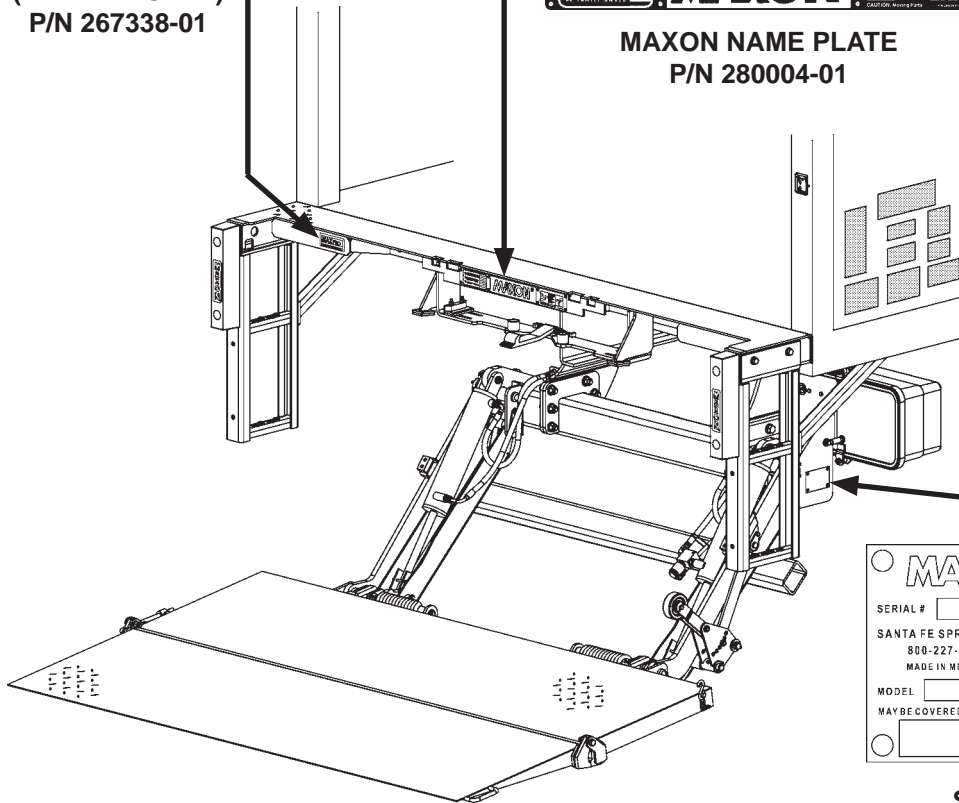

**SERIAL PLATE
(REF)**

FIG. 28-1

SYSTEM DIAGRAMS

PUMP & MOTOR SOLENOID OPERATION (GRAVITY DOWN)

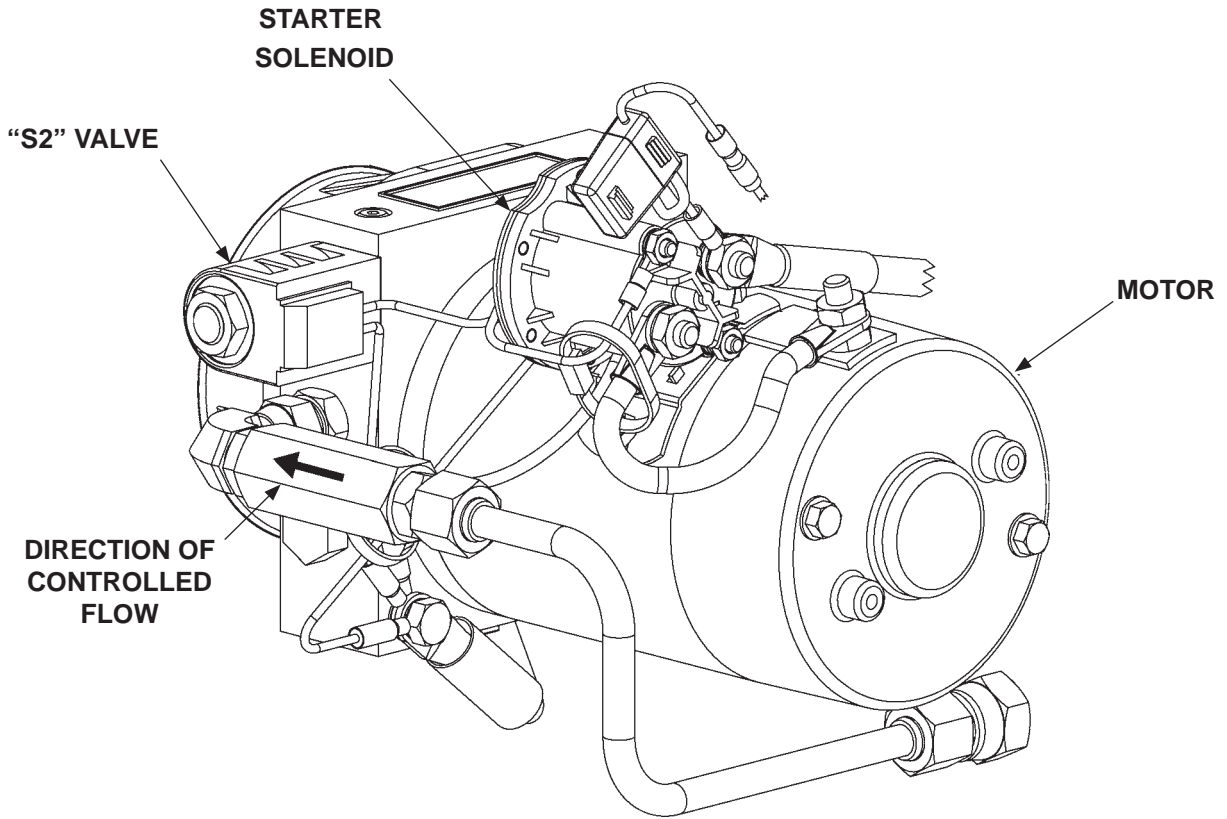

**GRAVITY DOWN POWER UNIT
FIG. 29-1**

POWER UNIT MOTOR & SOLENOID OPERATION				
LIFTGATE FUNCTION	PORT	SOLENOID OPERATION (✓ MEANS ENERGIZED)		
		MOTOR	VALVE "S2"	LOCK VALVE
RAISE	A	✓	-	-
LOWER	VENT	-	✓	✓
REFER TO VALVES SHOWN ON HYDRAULIC SCHEMATIC				

TABLE 29-1

PUMP & MOTOR SOLENOID OPERATION (POWER DOWN)

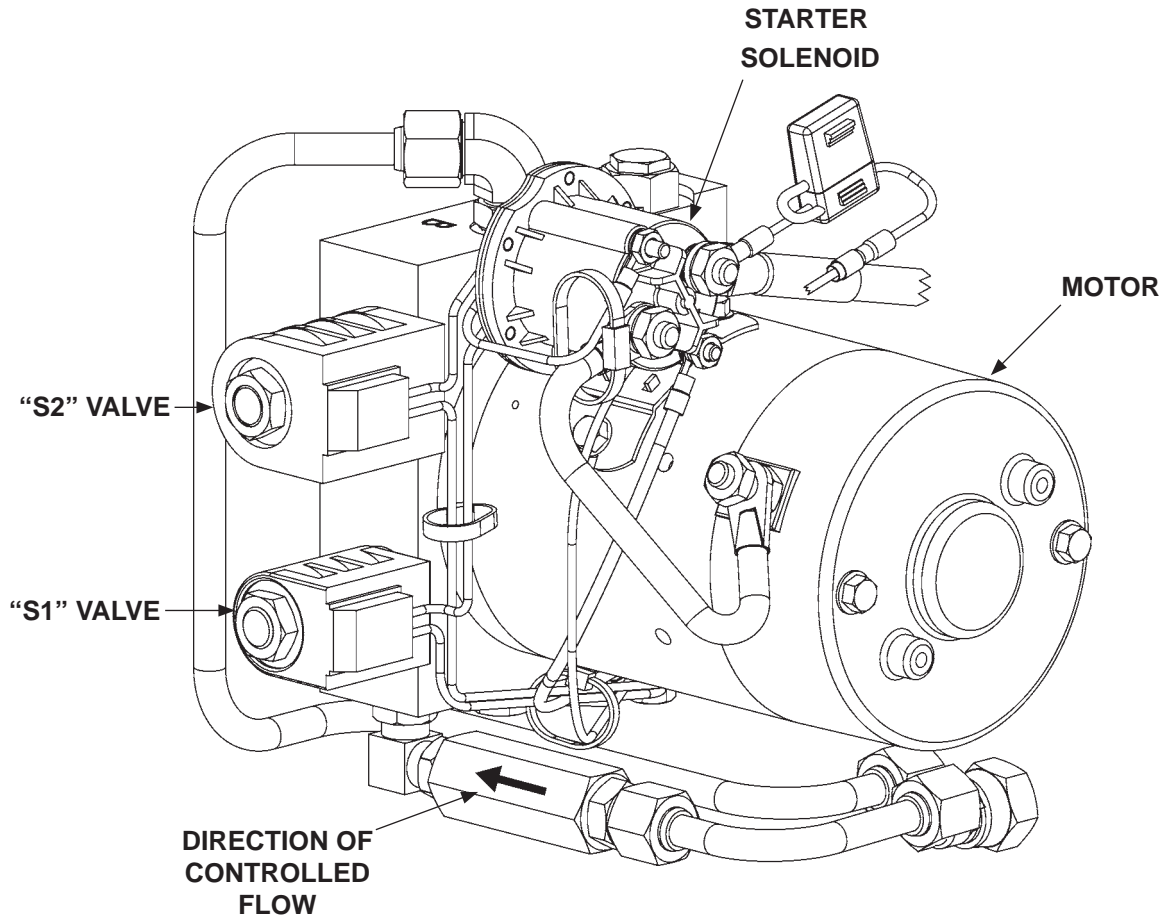

**POWER DOWN POWER UNIT
FIG. 30-1**

POWER UNIT MOTOR & SOLENOID OPERATION					
LIFTGATE FUNCTION	PORT	SOLENOID OPERATION (✓ MEANS ENERGIZED)			
		MOTOR	VALVE "S2"	VALVE "S1"	LOCK VALVE
RAISE	A	✓	-	✓	-
LOWER	B	✓	✓	-	✓
REFER TO VALVES SHOWN ON HYDRAULIC SCHEMATIC					

TABLE 30-1

HYDRAULIC SCHEMATIC (GRAVITY DOWN)

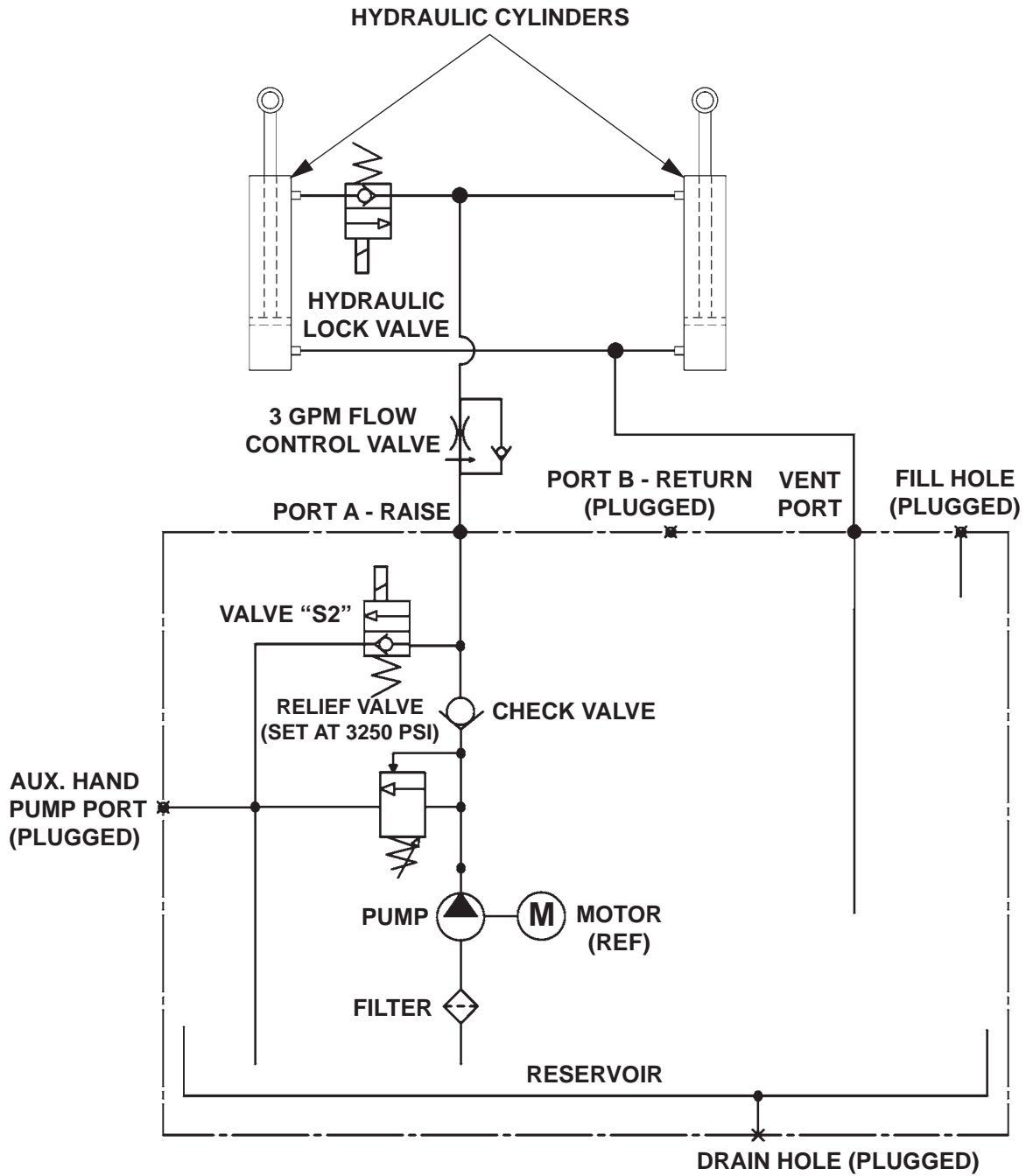

FIG. 31-1

HYDRAULIC SCHEMATIC (POWER DOWN)

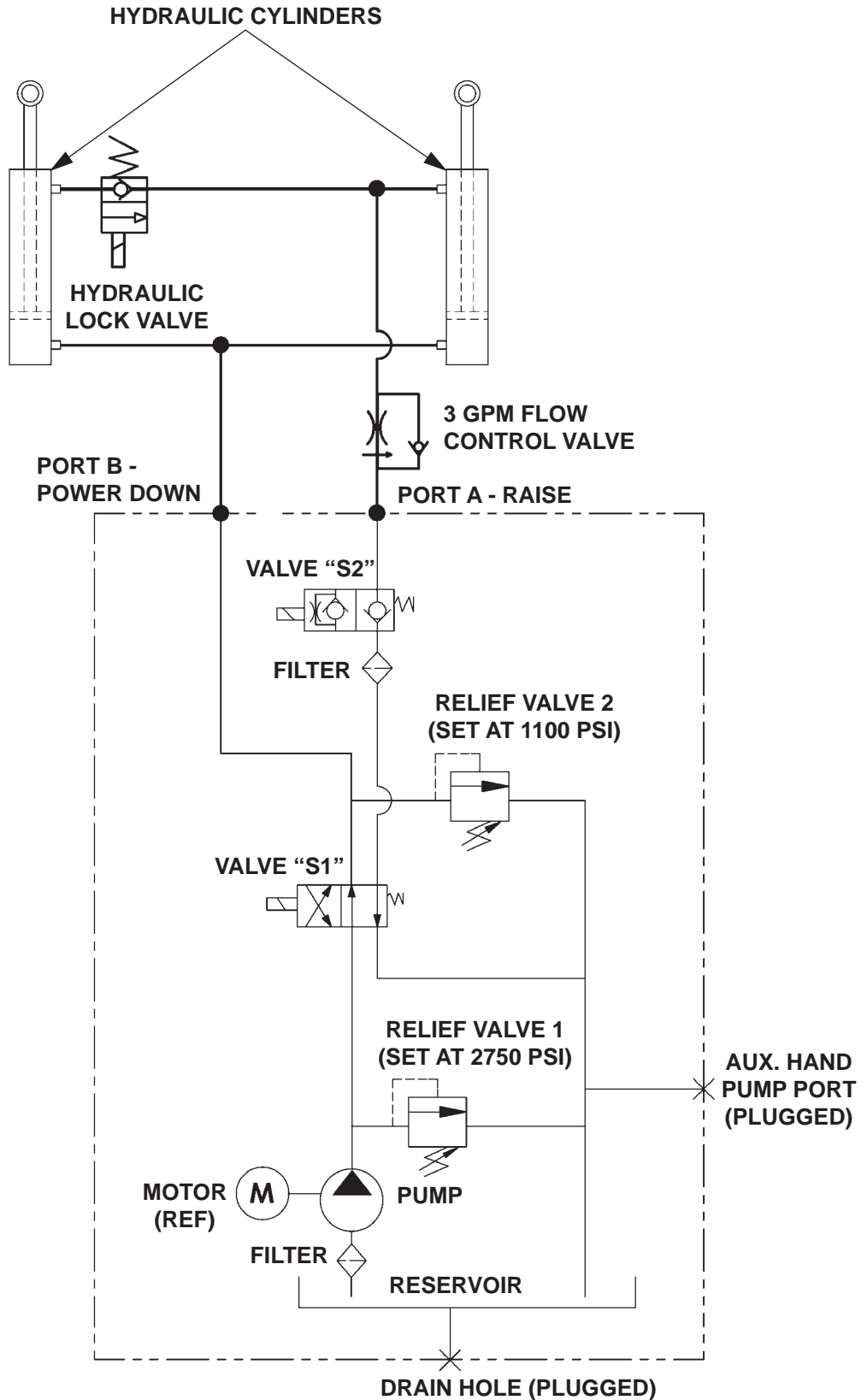

FIG. 32-1

ELECTRICAL SCHEMATIC (GRAVITY DOWN)

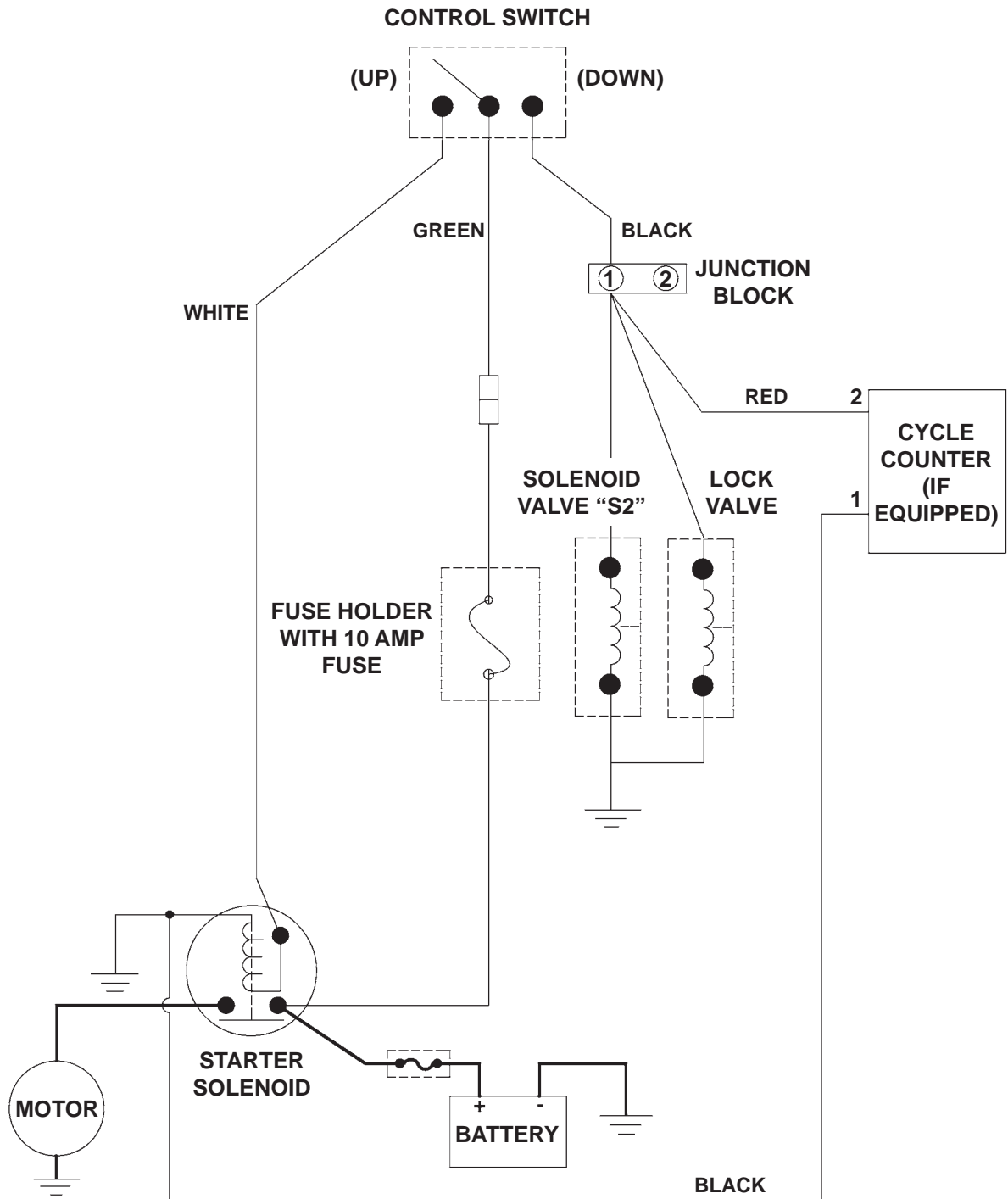

FIG. 33-1

ELECTRICAL SCHEMATIC (POWER DOWN)

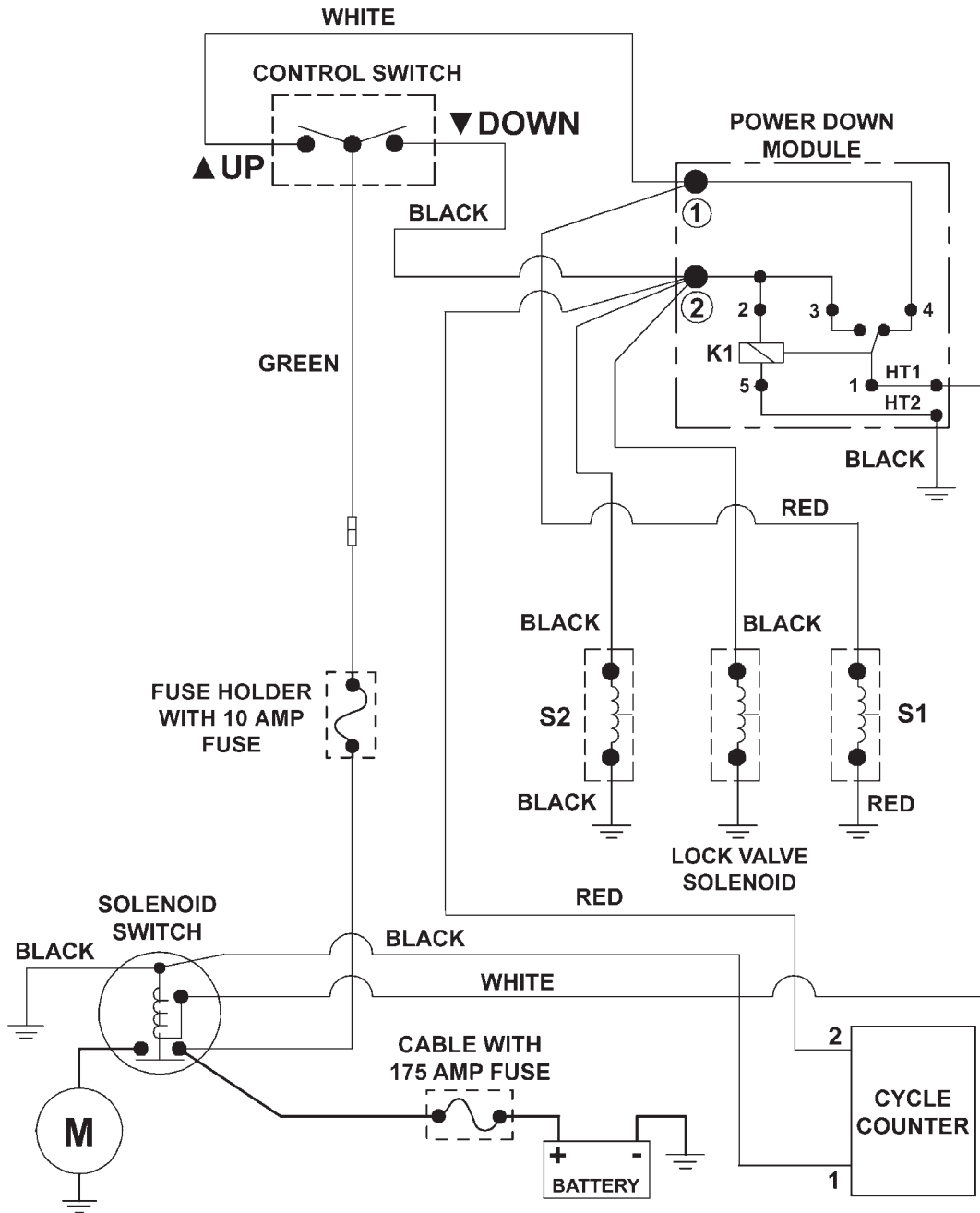

FIG. 34-1

MAXON

11921 Slauson Ave. Santa Fe Springs, CA. 90670 (800) 227-4116 FAX (888) 771-7713

ELECTRICAL VALUES

Solenoid Switch	12V	24V
Coil Resistance:	5.4Ω @70°F ±15%	20.1Ω @70°F ±15%
Ampere:	2.2A	1.2A
Coil terminal torque: 10-15 lb-in max.		
Contact terminal torque: 30-35 lb-in max.		
Solenoid Valves (S1 & S2)		
S1 Coil Resistance:	6.6Ω @ 70°F ±15%	26.7Ω @ 70°F ±15%
S1 Ampere:	1.8A	0.9A
S2 Coil Resistance:	7.5Ω @ 70°F ±15%	30.8Ω @ 70°F ±15%
S2 Ampere:	1.6A	0.78A
Coil terminal torque: 15-45 lb-in max.		
Valve cartridge torque: 25-30 lb-ft max.		
Coil nut torque: 15-45 lb-in		
Digital Cycle Counter		
Operation Voltage:	7V - 30V	
Ampere:	<2mA	
Solenoid Lock Valve		
Coil Resistance:	8.0Ω @ 70°F ±15%	30Ω @ 70°F ±15%
Ampere:	1.5A	0.8A
Coil terminal torque: 3-4.5 lb-ft max.		
Valve cartridge torque: 18.5-22 lb-ft max.		
Ground Cable		
Cap Screw Torque: 24 lb-ft max.		

TABLE 35-1

TROUBLESHOOTING

PLATFORM WILL NOT RAISE & MOTOR WILL NOT RUN

1. Connect voltmeter between motor solenoid terminal "B" and ground wires connection on pump (FIG. 36-1). Verify that full battery voltage is at "B". Recharge the battery if voltmeter indicates less than 12.6 volts dc.

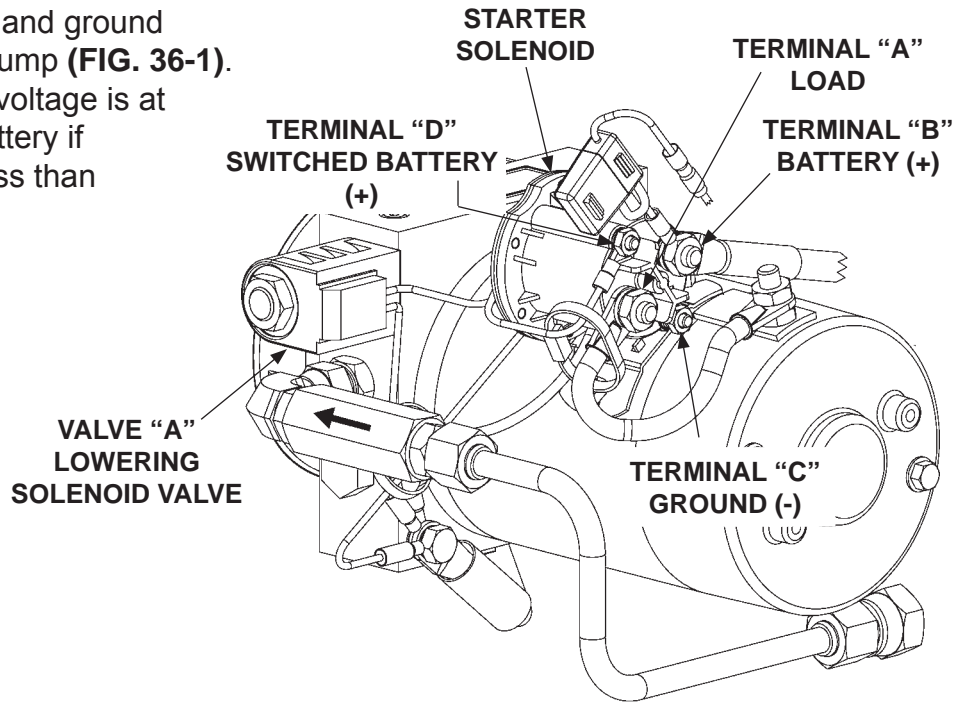

**12 VDC POWER UNIT
(GRAVITY DOWN)
FIG. 36-1**

2. Touch a jumper wire to terminals "B" & "D" (FIG. 36-1). If motor runs, check control switch, the switch connections, and white wire. Check and correct wiring connections or replace the control switch.
3. Touch heavy jumper cables to terminals "A" & "B" (FIG. 36-1).
 - a. If motor runs, replace the motor solenoid.
 - b. If motor does not run, repair or replace the pump motor.

PLATFORM WILL NOT RAISE, BUT MOTOR RUNS

1. Do the **CHECKING HYDRAULIC FLUID** procedure in this manual. If necessary, add hydraulic fluid.
2. Check for structural damage and replace worn parts.

CAUTION

Keep dirt, water and other contaminants from entering the hydraulic system. Before opening the hydraulic fluid reservoir filler cap, drain plug and hydraulic lines, clean up contaminants that can get in the openings. Also, protect the openings from accidental contamination during maintenance.

3. Check pump oil filter in the reservoir (FIGS. 37-1 and 37-2). Clean or replace filter, if necessary.

4. Check for dirty raising relief valve (FIGS. 37-1 and 37-2). Clean or replace relief valve if necessary.

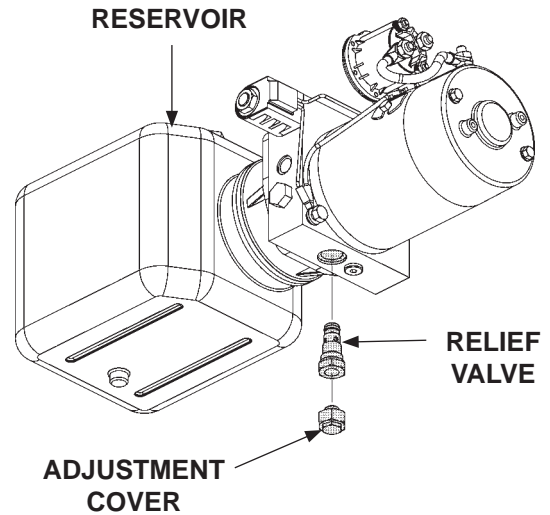

**CHECKING THE RAISING RELIEF VALVE
(GRAVITY DOWN POWER UNIT)
FIG. 37-1**

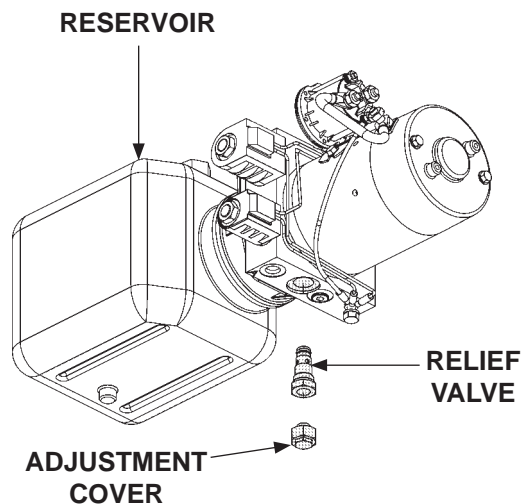

**CHECKING THE RAISING RELIEF VALVE
(POWER DOWN POWER UNIT)
FIG. 37-2**

TROUBLESHOOTING

PLATFORM RAISES BUT LEAKS DOWN

1. Check if the "A" (lowering) solenoid valve is constantly energized. Connect voltmeter negative (-) lead to ground (-) wires connection on pump and positive (+) lead to (+) terminal on the "A" (lowering) solenoid valve (**FIG. 38-1**). If voltmeter reads battery voltage, check for faulty wiring or toggle switch.

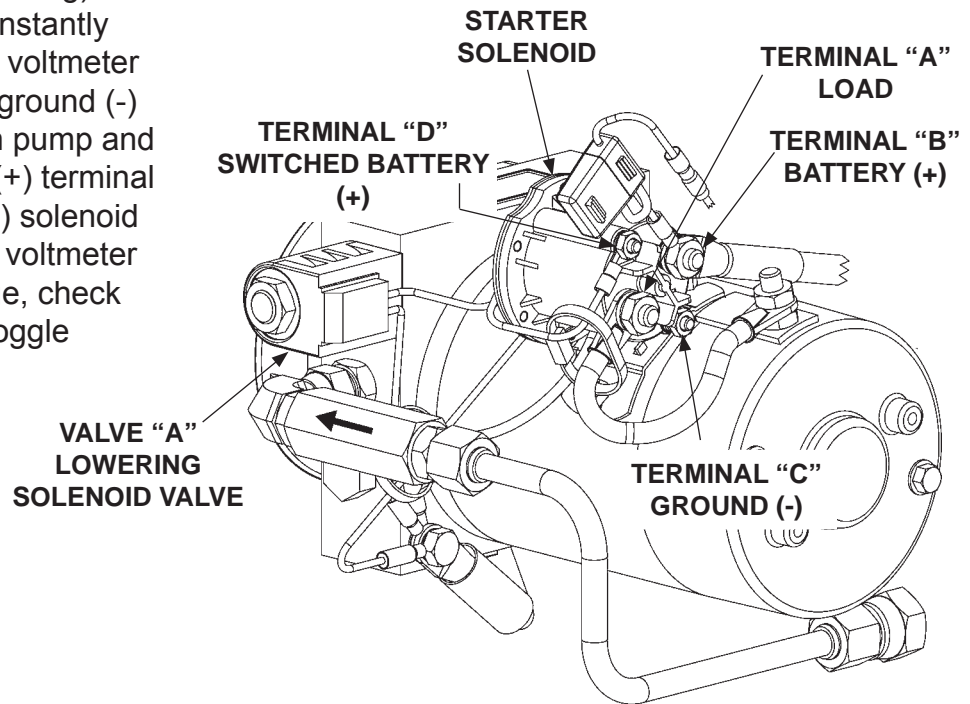

GRAVITY DOWN POWER UNIT
FIG. 38-1

MAXON

11921 Slauson Ave. Santa Fe Springs, CA. 90670 (800) 227-4116 FAX (888) 771-7713

CAUTION

Keep dirt, water and other contaminants from entering the hydraulic system. Before opening the hydraulic fluid reservoir filler cap, drain plug and hydraulic lines, clean up contaminants that can get in the openings. Also, protect the openings from accidental contamination during maintenance.

2. Make sure platform is on the ground. Remove lowering solenoid valve (FIGS. 39-1 and 39-2). Push on the plunger in the valve by inserting small screwdriver in the open end (FIG. 39-3). If the plunger does not move with a smooth, spring-loaded action (approximately 1/8"), replace the valve cartridge. Reinstall lowering solenoid valve. Torque valve cartridge to 25 - 30 lb-in and hex nut to 15 - 45 lb-in.

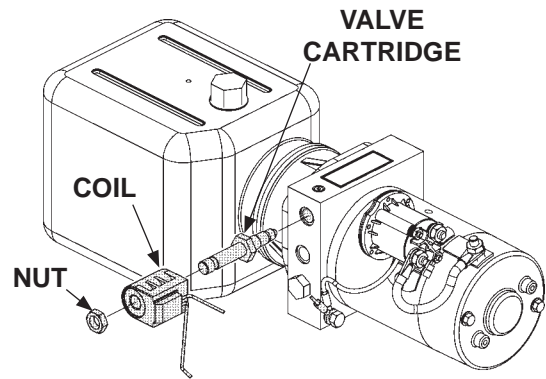

**REMOVING SOLENOID VALVE
(GRAVITY DOWN POWER UNIT)
FIG. 39-1**

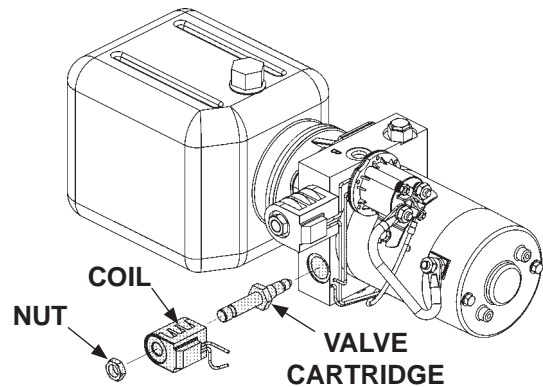

**REMOVING SOLENOID VALVE
(POWER DOWN POWER UNIT)
FIG. 39-2**

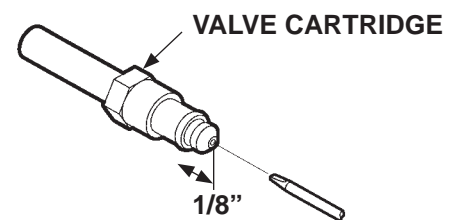

**CHECKING SOLENOID VALVE
FIG. 39-3**

3. Check the hydraulic cylinder. With the platform at vehicle floor level, remove the hydraulic line from the **LOWER** port on the cylinder (FIG. 39-4). Hold the control switch in the "RAISE" position for two seconds while you watch for hydraulic fluid at the **LOWER** port. A few drops of hydraulic fluid escaping the port is normal. However, if fluid streams out, piston seals are worn. Replace seals.

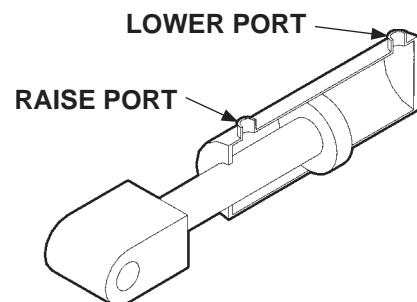
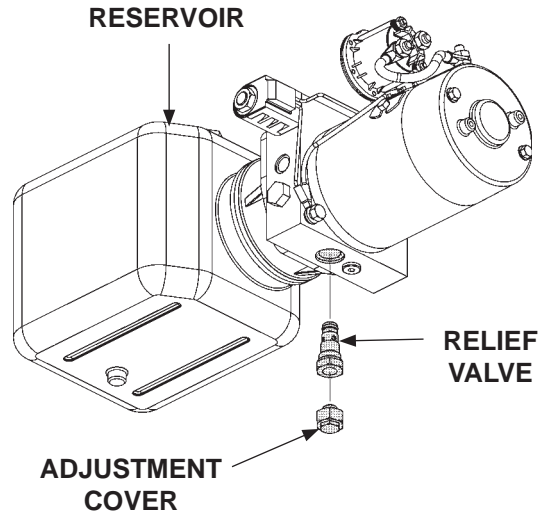

FIG. 39-4

TROUBLESHOOTING PLATFORM RAISES PARTIALLY AND STOPS

1. Lower the opened platform to the ground. Do the **CHECKING HYDRAULIC FLUID** procedure in this manual. If necessary, add hydraulic fluid.
2. Use voltmeter to verify the battery voltage is 12.6 volts or more under load from pump motor.
3. Check for structural damage and poor lubrication. Replace worn parts.



**CHECKING THE RAISING RELIEF VALVE
(GRAVITY DOWN POWER UNIT)
FIG. 40-1**

CAUTION

Keep dirt, water and other contaminants from entering the hydraulic system. Before opening the hydraulic fluid reservoir filler cap, drain plug and hydraulic lines, clean up contaminants that can get in the openings. Also, protect the openings from accidental contamination during maintenance.

4. Check for dirty raising relief valve (**FIGS. 40-1 and 40-2**). Clean or replace relief valve, if necessary.

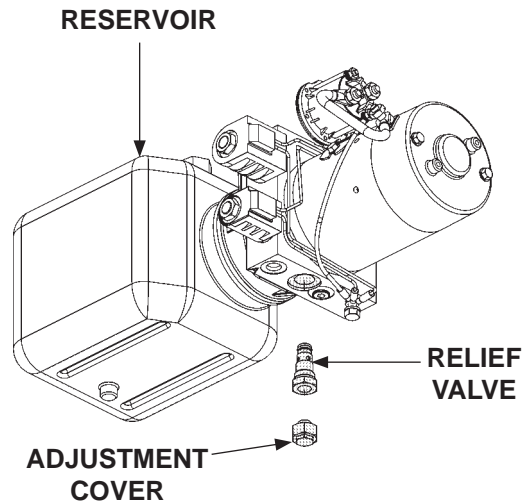

**CHECKING THE RAISING RELIEF VALVE
(POWER DOWN POWER UNIT)
FIG. 40-2**

5. Check the hydraulic cylinder. With the platform at vehicle floor level, remove the hydraulic line from the **LOWER** port on the cylinder (**FIG. 41-1**). Hold the control switch in the “**RAISE**” position for two seconds while you watch for hydraulic fluid at the **LOWER** port. A few drops of hydraulic fluid escaping the port is normal. However, if fluid streams out, piston seals are worn. Replace seals.

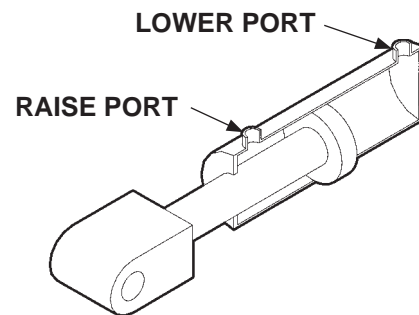

FIG. 41-1

6. Check pump oil filter in the reservoir (**FIGS. 40-1 and 40-2**). Clean or replace filter, if necessary.

TROUBLESHOOTING

LIFTGATE WILL NOT LIFT RATED CAPACITY

1. Use voltmeter to verify the battery voltage is 12.6 volts or more under load from pump motor.
2. Check for structural damage or lack of lubrication. Replace worn parts.

CAUTION

Keep dirt, water and other contaminants from entering the hydraulic system. Before opening the hydraulic fluid reservoir filler cap, drain plug and hydraulic lines, clean up contaminants that can get in the openings. Also, protect the openings from accidental contamination during maintenance.

3. Check the 3250 PSI relief valve as follows. With platform on the ground, remove plug from hand pump port (FIGS. 42-1 and 42-2). Install 0-4000 PSI pressure gauge in the hand pump port (FIGS. 42-1 and 42-2). Remove cover for access to relief valve. Hold the control switch in the "RAISE" position. Adjust the relief valve until the gauge reads 3250 PSI (FIGS. 42-1 and 42-2). Remove gauge and reinstall plug in the port. Then, reinstall relief valve cover.
4. Check if pump relief valve is dirty. Clean or replace relief valve, if necessary.

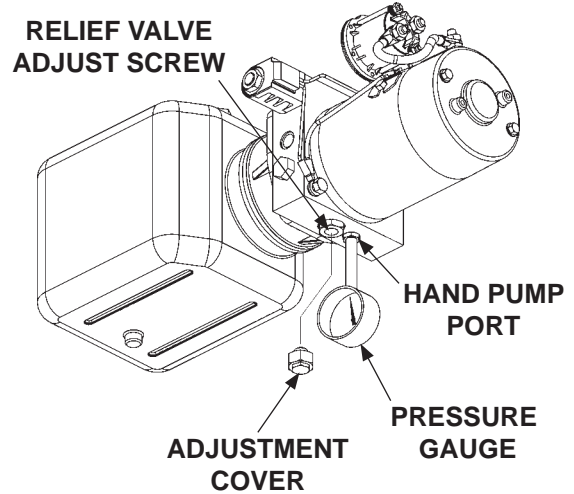

**ADJUSTING RAISING RELIEF VALVE
(GRAVITY DOWN POWER UNIT)
FIG. 42-1**

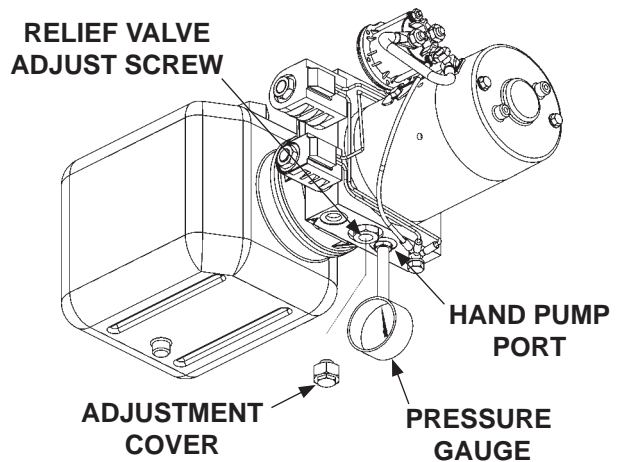

**ADJUSTING RAISING RELIEF VALVE
(POWER DOWN POWER UNIT)
FIG. 42-2**

5. Check the hydraulic cylinder. With the platform at vehicle floor level, remove the hydraulic line from the **LOWER** port on the cylinder (**FIG. 43-1**). Hold the control switch in the “**RAISE**” position for two seconds while you watch for hydraulic fluid at the **LOWER** port. A few drops of hydraulic fluid escaping the port is normal. However, if fluid streams out, piston seals are worn. Replace seals.
6. If pump cannot produce 3250 PSI or lift the load capacity with a minimum of 12.6 volts available, the pump is worn and needs to be replaced.

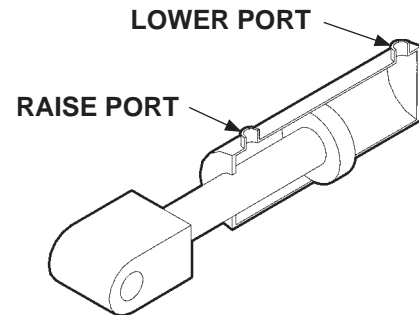
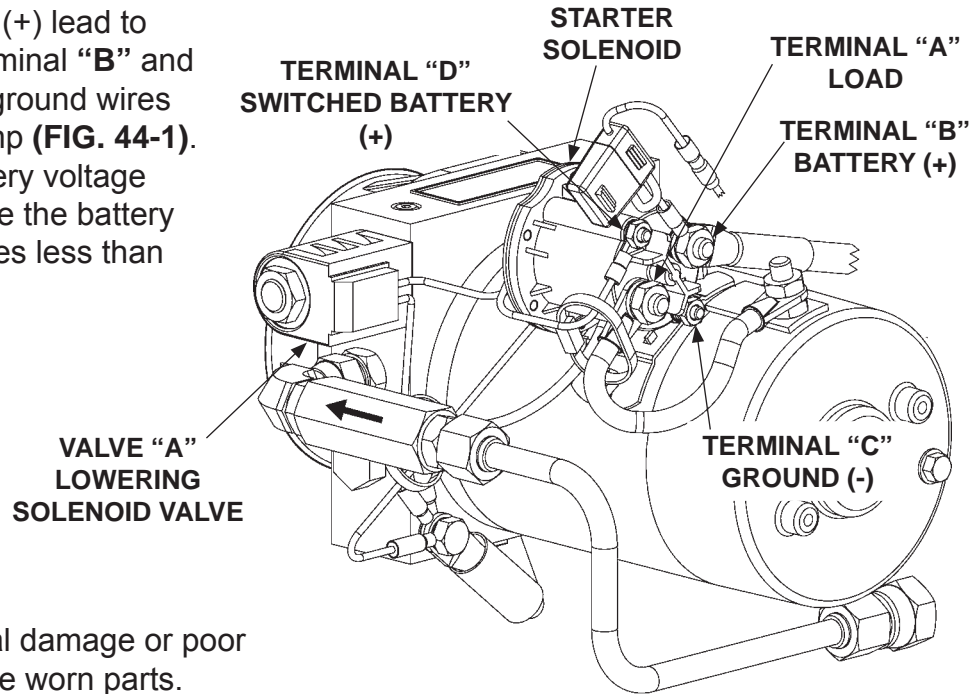

FIG. 43-1

TROUBLESHOOTING

PLATFORM WILL NOT LOWER, LOWERS TOO SLOWLY, OR TOO QUICKLY

1. Connect voltmeter (+) lead to motor solenoid terminal "B" and the (-) lead to the ground wires connection on pump (FIG. 44-1). Verify that full battery voltage is at "B". Recharge the battery if voltmeter indicates less than 12.6 volts dc.



GRAVITY DOWN POWER UNIT
FIG. 44-1

3. Check if the "D" terminal and "S2" (lowering) solenoid valve are getting battery voltage (FIG. 44-2). Connect voltmeter negative (-) lead to ground (-) wires connection on pump and positive (+) lead to the "D" terminal (FIG. 44-2). Hold control switch in the "LOWER" position. Then, connect voltmeter (+) lead to (+) terminal on the "S2" (lowering) solenoid valve (FIG. 44-2). If voltmeter shows a much lower reading than +12.6 volts dc or a reading of 0 volts, check for faulty control switch and wiring, battery cable, ground wire connections in pump assembly, and pump motor.

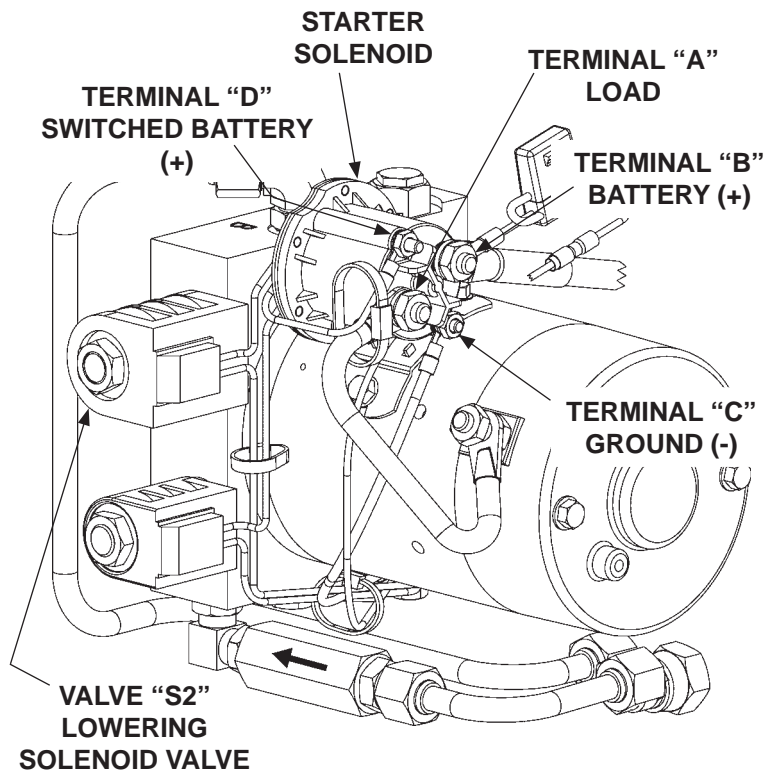

POWER DOWN POWER UNIT
FIG. 44-2

CAUTION

Keep dirt, water and other contaminants from entering the hydraulic system. Before opening the hydraulic fluid reservoir filler cap, drain plug and hydraulic lines, clean up contaminants that can get in the openings. Also, protect the openings from accidental contamination during maintenance.

CAUTION

To prevent damage to flow control valve, do not disassemble the valve.

4. Make sure platform is on the ground. Check the flow control valve as follows. Remove flow control valve (FIGS. 45-1 or 45-2). Ensure the flow control valve operates with a smooth spring-loaded action. Check for debris inside the valve. Clean or replace the flow control valve, if necessary. Reinstall flow control valve (if good) or a replacement.

5. Check the lowering solenoid valve as follows. Check if filtering screen is plugged. Clean carefully if required. Push on the plunger in the valve by inserting small screwdriver in the open end (FIG. 45-3). If the plunger does not move with a smooth, spring-loaded action (approximately 1/8"), replace the valve cartridge. **Reinstall lowering solenoid valve** (if good) or a replacement. **Torque valve cartridge to 25-30 lb-ft and hex nut to 30 lb-in.**

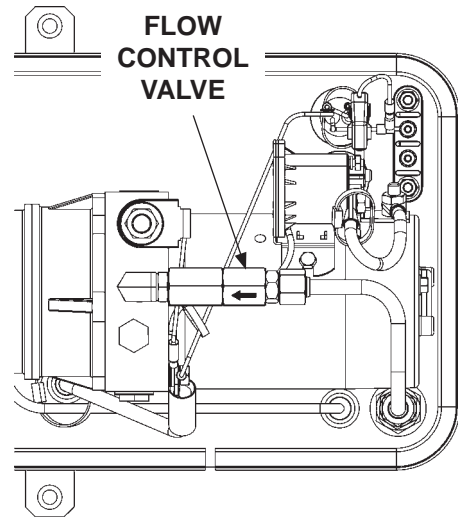

FLOW CONTROL VALVE ON BACK OF GRAVITY DOWN PUMP ASSEMBLY
FIG. 45-1

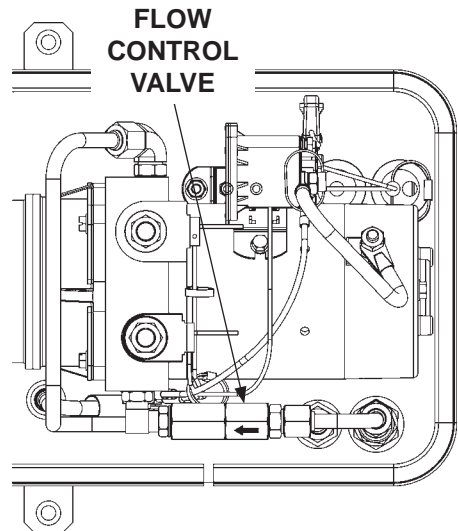

FLOW CONTROL VALVE ON BACK OF POWER DOWN PUMP ASSEMBLY
FIG. 45-2

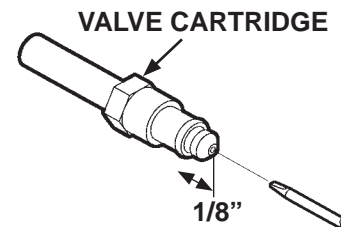

CHECKING SOLENOID VALVE
FIG. 45-3

