

M-16-40
AUGUST 2018

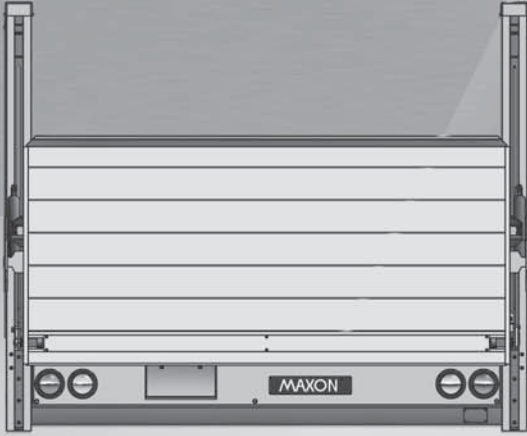

MAXON[®]

DMD Series

MAINTENANCE MANUAL
DMD-22 & DMD-33

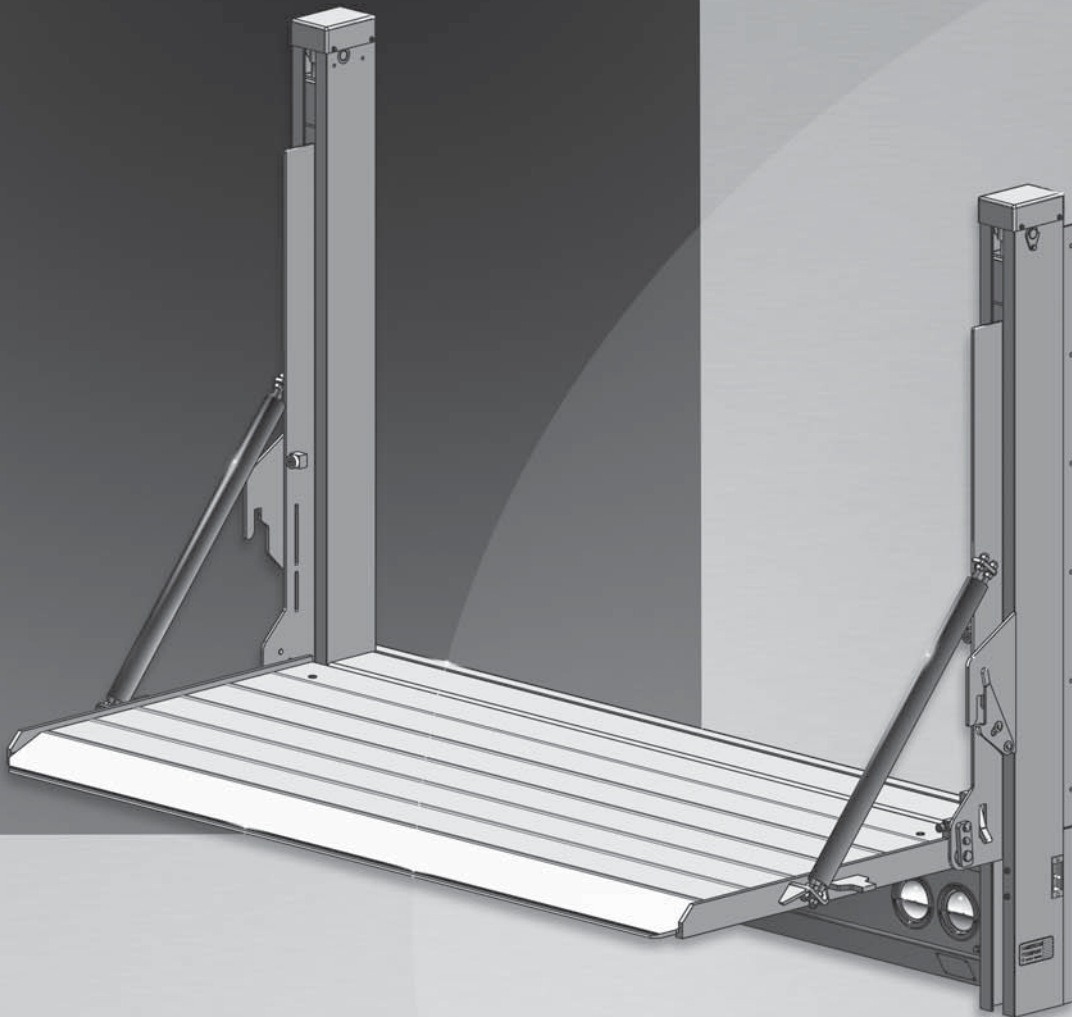

MAXON[®]

LIFT CORP.

11921 Slauson Ave.
Santa Fe Springs, CA. 90670

CUSTOMER SERVICE:

TELEPHONE (562) 464-0099 TOLL FREE (800) 227-4116

FAX: (888) 771-7713

NOTE: For latest version of all Manuals (and replacements), download the Manuals from Maxon's website at www.maxonlift.com.

WARRANTY/ RMA POLICY & PROCEDURE

LIFTGATE WARRANTY

Type of Warranty: Full Parts and Labor

Term of Warranty: Standard Liftgates - 2 years from ship date or 6,000 cycles
Premium Liftgates - 2 years from ship date or 10,000 cycles

This warranty shall not apply unless the product is installed, operated and maintained in accordance with MAXON Lift's specifications as set forth in MAXON Lift's Installation, Operation and Maintenance manuals. This warranty does not cover normal wear, maintenance or adjustments, damage or malfunction caused by improper handling, installation, abuse, misuse, negligence, or carelessness of operation. In addition, this warranty does not cover equipment that has had unauthorized modifications or alterations made to the product.

MAXON agrees to replace any components which are found to be defective during the first 2 years of service, and will reimburse for labor based on MAXON's Liftgate Warranty Flat Rate Schedule. (Copy of the Flat Rate is available at www.maxonlift.com.)

All warranty repairs must be performed by an authorized MAXON warranty facility. For any repairs that may exceed \$500, including parts and labor, MAXON's Technical Service Department must be notified and an "Authorization Number" obtained.

All claims for warranty must be received within 30 Days of the repair date, and include the following information:

1. Liftgate Model Number and Serial Number
2. The End User must be referenced on the claim
3. Detailed Description of Problem
4. Corrective Action Taken, and Date of Repair
5. Parts used for Repair, Including MAXON Part Number(s)
6. MAXON R.M.A. # and/or Authorization # if applicable (see below)
7. Person contacted at MAXON if applicable
8. Claim must show detailed information i.e. Labor rate and hours of work performed

Warranty claims can also be placed online at www.maxonlift.com. Online claims will be given priority processing.

All claims for warranty will be denied if paperwork has not been received or claim submitted via Maxon website for processing by MAXON's Warranty Department within 30 days of repair date.

All components may be subject to return for inspection, prior to the claim being processed. MAXON products may not be returned without prior written approval from MAXON's Technical Service Department. Returns must be accompanied by a copy of the original invoice or reference with original invoice number and are subject to a credit deduction to cover handling charges and any necessary reconditioning costs. **Unauthorized returns will be refused and will become the responsibility of the returnee.**

Any goods being returned to MAXON Lift must be pre-approved for return, and have the R.M.A. number written on the outside of the package in plain view, and returned freight prepaid. All returns are subject to a 15% handling charge if not accompanied by a detailed packing list. Returned parts are subject to no credit and returned back to the customer. Defective parts requested for return must be returned within 30 days of the claim date for consideration to:

MAXON Lift Corp.
10321 Greenleaf Ave., Santa Fe Springs, CA 90670
Attn: RMA#__

MAXON's warranty policy does not include the reimbursement for travel time, towing, vehicle rental, service calls, oil, batteries or loss of income due to downtime. Fabrication or use of non Maxon parts, which are available from MAXON, are also not covered.

MAXON's Flat Rate Labor Schedule takes into consideration the time required for diagnosis of a problem.

All Liftgates returned are subject to inspection and a 15% restocking fee. Any returned Liftgates or components that have been installed or not returned in new condition will be subject to an additional reworking charge, which will be based upon the labor and material cost required to return the Liftgate or component to new condition.

PURCHASE PART WARRANTY

Term of Warranty: 1 Year from Date of Purchase.

Type of Warranty: Part replacement only. MAXON will guarantee all returned genuine MAXON replacement parts upon receipt and inspection of parts and original invoice.

All warranty replacements parts will be sent out via ground freight. If a rush shipment is requested, all freight charges will be billed to the requesting party.

TABLE OF CONTENTS

WARNINGS	6
SAFETY INSTRUCTIONS	7
LIFTGATE TERMINOLOGY	8
PERIODIC MAINTENANCE	9
PERIODIC MAINTENANCE CHECKS	9
PREVENTATIVE MAINTENANCE (PM) CHECKLIST.....	10
CHECKING HYDRAULIC FLUID	11
CHANGING HYDRAULIC FLUID	13
PRESSURIZING HYDRAULIC SYSTEM.....	15
TORSION BAR REPLACEMENT & ADJUSTMENT.....	16
DECALS	26
SYSTEM DIAGRAMS	28
PUMP MOTOR & VALVE OPERATION (MANUAL CLOSE).....	28
PUMP MOTOR & VALVE OPERATION (EQUIPPED WITH HYDRAULIC CLOSER).....	29
HYDRAULIC SCHEMATIC (MANUAL CLOSE)	30
HYDRAULIC SCHEMATIC (EQUIPPED WITH HYDRAULIC CLOSER).....	31
ELECTRICAL SCHEMATIC (MANUAL CLOSE)	32
ELECTRICAL SCHEMATIC (EQUIPPED WITH HYDRAULIC CLOSER).....	33
ELECTRICAL SCHEMATIC - JUMPER HARNESS ASSEMBLY	34
ELECTRICAL SCHEMATIC - HOUSING COVER ASSEMBLY (WITHOUT LIGHTS).....	35
ELECTRICAL SCHEMATIC - HOUSING COVER ASSEMBLY (WITH FOUR LIGHTS)....	36
ELECTRICAL SCHEMATIC - HOUSING COVER ASSEMBLY, FOREIGN VEHICLE (WITH 6 LIGHTS).....	37
DMD ELECTRICAL VALUES	38
RECOMMENDED BOLT TORQUES	39

THIS PAGE INTENTIONALLY LEFT BLANK

Comply with the following **WARNINGS** and **SAFETY INSTRUCTIONS** while maintaining Liftgates. See Operation Manual for operating safety requirements.

WARNING

- Do not stand, or allow obstructions, under the platform when lowering the Liftgate. **Be sure your feet are clear of the Liftgate.**
- **Keep fingers, hands, arms, legs, and feet clear of moving Liftgate parts (and platform edges) when operating the Liftgate.**
- **Correctly stow platform when not in use. Extended platforms could create a hazard for people and vehicles passing by.**
- **Disconnect Liftgate power cable from battery** before repairing or servicing Liftgate.
- If it is necessary to stand on the platform while maintaining the Liftgate, keep your feet and any objects clear of the inboard edge of the platform. Your feet or objects on the platform can become trapped between the platform and the Liftgate housing cover.
- Recommended practices for welding on steel parts are contained in the current **AWS (American Welding Society) D1.1 Structural Welding Code - Steel**. Damage to Liftgate and/or vehicle, and personal injury could result from welds that are done incorrectly.
- Recommended practices for welding on aluminum parts are contained in the current **AWS (American Welding Society) D1.2 Structural Welding Code - Aluminum**. Damage to Liftgate and/or vehicle, and personal injury could result from welds that are done incorrectly.

MAXON[®]

11921 Slauson Ave. Santa Fe Springs, CA 90670 (800) 227-4116 FAX (888) 771-7713

SAFETY INSTRUCTIONS

- Read and understand the instructions in this **Maintenance Manual** before performing maintenance on the Liftgate.
- Before operating the Liftgate, read and understand the operating instructions in **Operation Manual**.
- Comply with all **WARNING** and instruction decals attached to the Liftgate.
- Keep decals clean and legible. If decals are illegible or missing, replace them. Free replacement decals are available from **Maxon Customer Service**.
- Consider the safety and location of bystanders and location of nearby objects when operating the Liftgate. Stand to one side of the platform while operating the Liftgate.
- Do not allow untrained persons to operate the Liftgate.
- Wear appropriate safety equipment such as protective eyeglasses, faceshield and clothing while performing maintenance on the Liftgate and handling the battery. Debris from drilling and contact with battery acid may injure unprotected eyes and skin.
- Be careful working by an automotive type battery. Make sure the work area is well ventilated and there are no flames or sparks near the battery. Never lay objects on the battery that can short the terminals together. If battery acid gets in your eyes, immediately seek first aid. If acid gets on your skin, immediately wash it off with soap and water.
- If an emergency situation arises (vehicle or Liftgate) while operating the Liftgate, release the control switch to stop the Liftgate.
- A correctly installed Liftgate operates smoothly and reasonably quiet. The only noticeable noise during operation comes from the power unit while the platform is raised. Listen for scraping, grating and binding noises and correct the problem before continuing to operate Liftgate.
- Use only **Maxon Authorized Parts** for replacement parts. Provide Liftgate model and serial number information with your parts order. Order replacement parts from:

MAXON LIFT CORP. Customer Service
11921 Slauson Ave., Santa Fe Springs, CA 90670

Online: www.maxonlift.com
Express Parts Ordering: Phone (800) 227-4116 ext. 4345
Email: Ask your Customer Service representative

LIFTGATE TERMINOLOGY

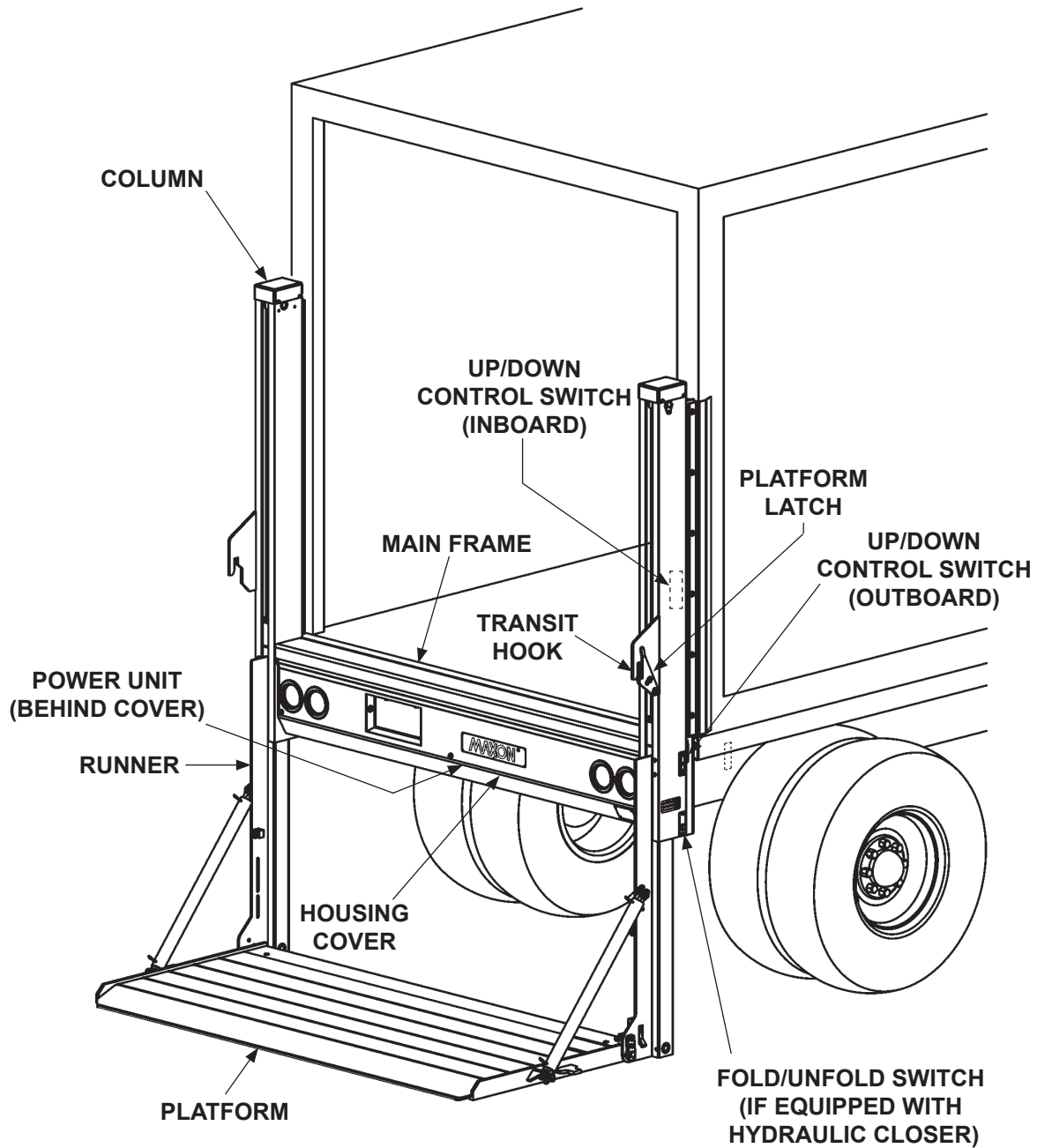

MAXON[®]

11921 Slauson Ave. Santa Fe Springs, CA. 90670 (800) 227-4116 FAX (888) 771-7713

PERIODIC MAINTENANCE

PERIODIC MAINTENANCE CHECKS

WARNING

Never operate the Liftgate with parts loose or missing.

NOTE: Photocopy the PM CHECKLIST on the next page to help keep track of periodic maintenance on the Liftgate. Keep completed form with maintenance records.

Annually

Visually check the entire Liftgate for excessively worn parts and broken welds, especially the hinge pins. See **Parts Manual** for replacement parts. Also, do the **Semi-annual** and **Quarterly Maintenance** checks.

Semi-annually

Visually check the platform hinge pins for excessive wear and broken welds. See **Parts Manual** for replacement parts. Also, do the **Quarterly Maintenance** checks.

Quarterly

Check the hydraulic fluid level in the pump reservoir. Refer to the **CHECKING HYDRAULIC FLUID** procedure in the **PERIODIC MAINTENANCE** section.

- If hydraulic fluid appears contaminated, refer to the **CHANGING HYDRAULIC FLUID** procedure on following page.
- Keep track of the grade of hydraulic fluid in the pump reservoir. Never mix two different grades of fluid.
- Check lines and fittings for chaffing and fluid leaks. Replace if necessary.
- Check electrical wiring for chaffing and make sure wiring connections are tight and free of corrosion.
- Check that all **WARNING** and **instruction decals** are in place and legible.
- Check for loose or missing nuts, bolts, covers, roll pins, screws and pins.
- Check that platform latch and transit hook mechanisms work correctly and no parts are missing.

CAUTION

Damaged cylinder seals and contaminated hydraulic fluid can result from painting the polished portion of the cylinder rod. To prevent damage, protect the exposed polished portion of the cylinder rod while painting.

- Check for rust and oily surfaces on Liftgate. If there is rust or oil on the Liftgate, clean it off. Touch up the paint where bare metal is showing.

PERIODIC MAINTENANCE PREVENTATIVE MAINTENANCE (PM) CHECKLIST

PM Interval: 3 Months

Date: ___ / ___ / ___

Equipment: _____

W/O # _____

Location: _____

Mechanic: _____

Serial # _____

Model # _____

Check Appropriate Box. "

MAXON 1 st , 2 nd and 3 rd Quarter Liftgate Preventative Maintenance (PM) Procedures				
<input type="checkbox"/> Satisfactory	<input type="checkbox"/> Repair Required	<input type="checkbox"/> Corrected	1	Verify if the Quarterly or Annual PM is due by checking the PM sticker on the curbside Liftgate column.
<input type="checkbox"/> Satisfactory	<input type="checkbox"/> Repair Required	<input type="checkbox"/> Corrected	2	Check for oil leaks at: cylinders, valves, and fittings.
<input type="checkbox"/> Satisfactory	<input type="checkbox"/> Repair Required	<input type="checkbox"/> Corrected	3	Check for damage: platform, column, runners and hydraulic tubes.
<input type="checkbox"/> Satisfactory	<input type="checkbox"/> Repair Required	<input type="checkbox"/> Corrected	4	Check for loose or missing nuts, bolts, covers, roll pins, screws and pins.
<input type="checkbox"/> Satisfactory	<input type="checkbox"/> Repair Required	<input type="checkbox"/> Corrected	5	Check for cracked welds at: columns, runners, platform, main housing and vehicle door frame.
<input type="checkbox"/> Satisfactory	<input type="checkbox"/> Repair Required	<input type="checkbox"/> Corrected	6	Check platform lowering speed: Range is 16 - 30 seconds. Check cylinder lock valves for proper operation.
<input type="checkbox"/> Satisfactory	<input type="checkbox"/> Repair Required	<input type="checkbox"/> Corrected	7	Check platform pins and couplers.
<input type="checkbox"/> Satisfactory	<input type="checkbox"/> Repair Required	<input type="checkbox"/> Corrected	8	Check platform raising speed: Range is 12-13 seconds.
<input type="checkbox"/> Satisfactory	<input type="checkbox"/> Repair Required	<input type="checkbox"/> Corrected	9	Check that platform unlatches, unfolds & folds smoothly & latches securely.
<input type="checkbox"/> Satisfactory	<input type="checkbox"/> Repair Required	<input type="checkbox"/> Corrected	10	Check switches and wiring connections on Liftgate as well as pump inside main housing. Also check ground straps.
<input type="checkbox"/> Satisfactory	<input type="checkbox"/> Repair Required	<input type="checkbox"/> Corrected	11	Check the gear pump for unusual noise, i.e. squealing or extreme RPM output.
<input type="checkbox"/> Satisfactory	<input type="checkbox"/> Repair Required	<input type="checkbox"/> Corrected	12	Checking Oil Level: gravity down with the platform unfolded and on the ground. Oil level should be as shown in Installation Manual, "CHECKING HYDRAULIC FLUID". Check for contamination, change if needed.
<input type="checkbox"/> Satisfactory	<input type="checkbox"/> Repair Required	<input type="checkbox"/> Corrected	13	Check batteries: load test, corrosion, cables, hold downs and water level.
<input type="checkbox"/> Satisfactory	<input type="checkbox"/> Repair Required	<input type="checkbox"/> Corrected	14	Check all charging and ground cable connections.
<input type="checkbox"/> Satisfactory	<input type="checkbox"/> Repair Required	<input type="checkbox"/> Corrected	15	Complete a new PM sticker and install it on the curbside column of the Liftgate. The next PM date is 3 months from the completed PM date. Indicate on the PM sticker if 1 st , 2 nd , 3 rd or 4 th PM.
<input type="checkbox"/> Satisfactory	<input type="checkbox"/> Repair Required	<input type="checkbox"/> Corrected	16	Check that platform latch and transit hook mechanisms work correctly and no parts are missing.

MAXON 4 th Quarter Liftgate Preventative Maintenance (PM). Note: Includes steps 1-16				
<input type="checkbox"/> Satisfactory	<input type="checkbox"/> Repair Required	<input type="checkbox"/> Corrected	17	Change hydraulic fluid.
<input type="checkbox"/> Satisfactory	<input type="checkbox"/> Repair Required	<input type="checkbox"/> Corrected	18	Inspect wear on slide pads.

For more detailed information, please refer to the product maintenance manuals. Use only genuine Maxon replacement parts for all repairs.

TABLE 10-1

MAXON[®]

11921 Slauson Ave. Santa Fe Springs, CA. 90670 (800) 227-4116 FAX (888) 771-7713

PERIODIC MAINTENANCE

CHECKING HYDRAULIC FLUID

CAUTION

Keep dirt, water and other contaminants from entering the hydraulic system. Before opening the hydraulic fluid reservoir filler cap, drain plug and hydraulic lines, clean up contaminants that can get in the openings. Also, protect the openings from accidental contamination. Never mix synthetic fluids with conventional hydraulic fluids. Hydraulic system must be purged if the fluids are mixed.

NOTE: Liftgate is shipped with **Exxon Univis HVI-13** hydraulic fluid in the hydraulic cylinders. **Exxon Univis HVI-13** hydraulic fluid is recommended for operating temperatures of **-40 to +120° F**. Refer to decal in pump box. Under certain conditions, other brands and grades of oil may be used as substitutes for the recommended oil. Refer to **TABLES 12-1 & 12-2**.

NOTE: If the hydraulic fluid in the reservoir is contaminated, do the **CHANGING HYDRAULIC FLUID** procedure in this section.

1. Open and lower platform to the ground (**FIG. 11-1**). Refer to **Operation Manual** for detailed operating instructions.
2. Unbolt main housing cover as shown in **FIG. 11-1**. Remove cover.
3. Check the hydraulic fluid level in reservoir as follows. With platform on the ground, level should be as shown in **FIG. 11-2**.
4. If needed, add fluid to the reservoir as follows. Remove filler cap (**FIG. 11-2**). Fill the reservoir with hydraulic fluid to level shown in **FIG. 11-2**. Reinstall filler cap.

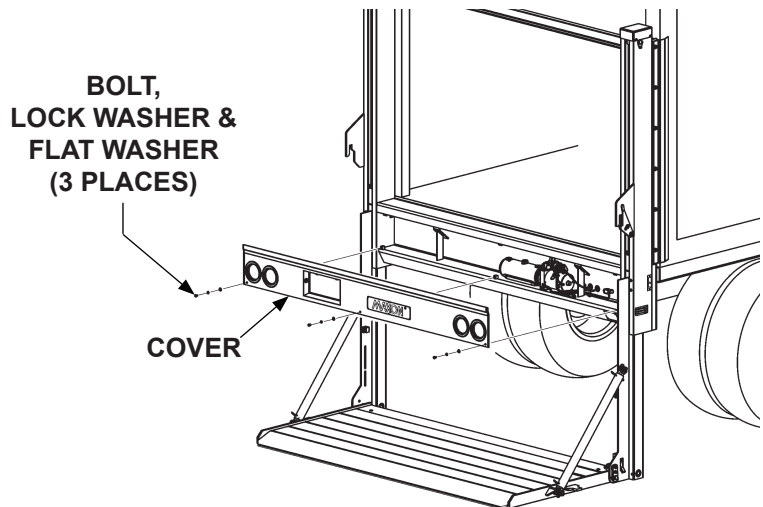

**UNBOLTING/ BOLTING COVER
(PLATFORM ON THE GROUND)
FIG. 11-1**

CAUTION
Main housing cover must be correctly secured to prevent it from becoming a hazard.

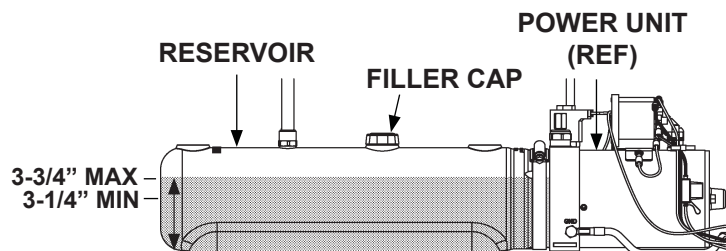

**POWER UNIT FLUID LEVEL
(MANUAL CLOSE POWER UNIT SHOWN)
FIG. 11-2**

5. Bolt on the main housing cover as shown in **FIG. 11-1**. Torque the 5/16"-18 cover bolts from **10 to 14 lb-ft**.

ISO 32 HYDRAULIC OIL	
RECOMMENDED BRANDS	PART NUMBER
CHEVRON	HIPERSYN 32
KENDALL	GOLDEN MV
SHELL	TELLUS S2 VX 32
EXXONMOBIL	UNIVIS N-32, DTE-24

TABLE 12-1

ISO 15 OR MIL-H-5606 HYDRAULIC OIL	
RECOMMENDED BRANDS	PART NUMBER
CHEVRON	FLUID A, AW-MV-15
KENDALL	GLACIAL BLU
SHELL	TELLUS S2 VX 15
EXXONMOBIL	UNIVIS HVI-13
ROSEMEAD	THS FLUID 17111

TABLE 12-2

PERIODIC MAINTENANCE CHANGING HYDRAULIC FLUID

CAUTION

Keep dirt, water and other contaminants from entering the hydraulic system. Before opening the hydraulic fluid reservoir filler cap, drain plug and hydraulic lines, clean up contaminants that can get in the openings. Also, protect the openings from accidental contamination. Never mix synthetic fluids with conventional hydraulic fluids. Hydraulic system must be purged if the fluids are mixed.

NOTE: Liftgate is shipped with **Exxon Univis HVI-13** hydraulic fluid in the hydraulic cylinders. **Exxon Univis HVI-13** hydraulic fluid is recommended for operating temperatures of **-40 to +120° F**. Refer to decal in pump box. Under certain conditions, other brands and grades of oil may be used as substitutes for the recommended oil. Refer to **TABLES 12-1 & 12-2**.

1. Open and lower platform to the ground (**FIG. 13-1**). Refer to **Operation Manual** for detailed operating instructions.

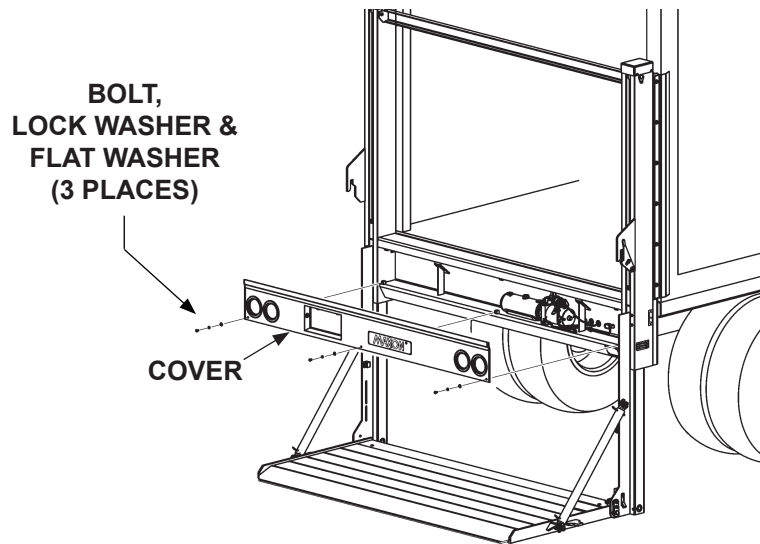

2. Unbolt main housing cover as shown in **FIG. 13-1**. Remove cover.

3. Remove drain plug (**FIG. 13-2**). Then, drain hydraulic fluid from reservoir.

4. Reinstall drain plug (**FIG. 13-2**). Then, add new **Univis HVI-13** hydraulic fluid to level shown in **FIG. 13-2**.

5. Remove filler cap (**FIG. 13-2**). Then, add new **Univis HVI-13** hydraulic fluid to level shown in **FIG. 13-2**. Reinstall filler cap.

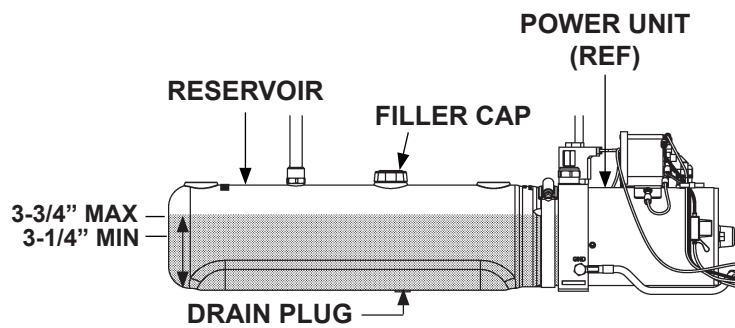

**POWER UNIT FLUID LEVEL
(MANUAL CLOSE POWER UNIT SHOWN)
FIG. 13-2**

6. Raise platform to bed height (**FIG. 14-1**). Continue to hold **UP/DOWN** control switch for 30 - 60 seconds to circulate hydraulic fluid through slave cylinder and reservoir (**FIG. 14-2**). Release **UP/DOWN** control switch.

NOTE: Three cycles of draining, filling, and circulating hydraulic fluid should be enough to fill the system with new hydraulic fluid.

7. Repeat **instructions 1 through 5**, two times. Keep the platform open and cover removed.

8. Lower platform to the ground (**FIG. 14-3**).

CAUTION

Main housing cover must be correctly secured to prevent it from becoming a hazard.

9. Bolt on the main housing cover as shown in **FIG. 14-3**. Torque the 5/16"-18 cover bolts from **10 to 14 lb-ft**.

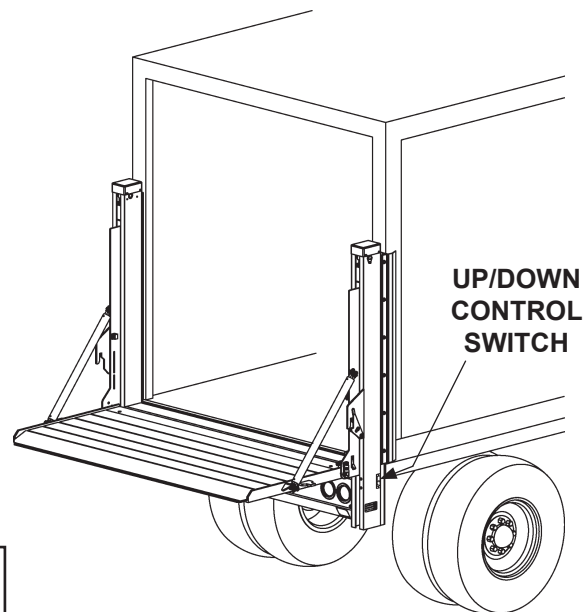

PLATFORM AT BED HEIGHT
FIG. 14-1

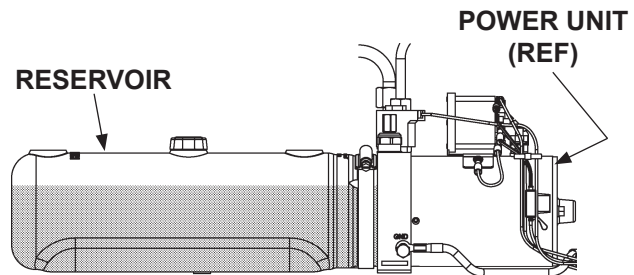

POWER UNIT
(MANUAL CLOSE POWER UNIT SHOWN)
FIG. 14-2

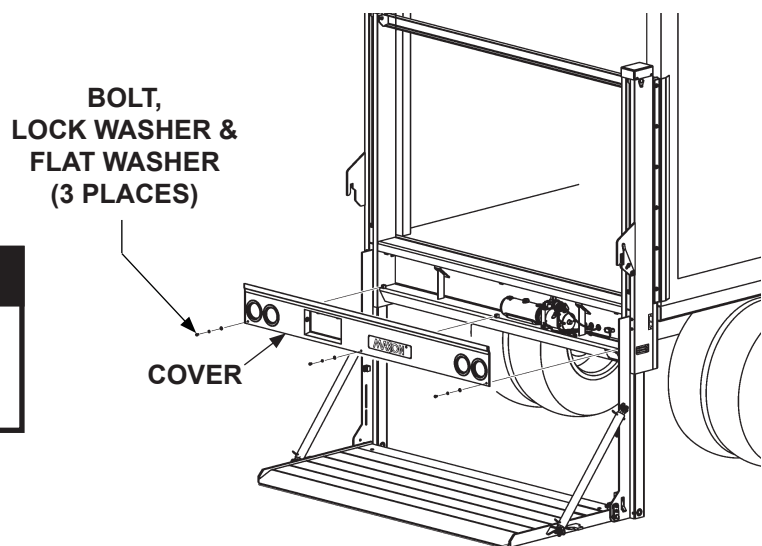

BOLTING ON COVER
FIG. 14-3

PERIODIC MAINTENANCE

PRESSURIZING HYDRAULIC SYSTEM

! CAUTION

Operating Liftgate, under certain conditions, with air in system could result in damage to lift and load as well as personal injury. If lines are opened & closed or replaced, and if power unit or cylinders are replaced, pressurize hydraulic system before operating Liftgate with a passenger or load.

NOTE: When pump pressurizes fluid in hydraulic system, air is bled into reservoir through slave cylinder return line.

To pressurize lifting cylinders, hold outboard control switch in **UP** position for 30 - 60 seconds (**FIG. 15-1**). Then, release toggle switch.

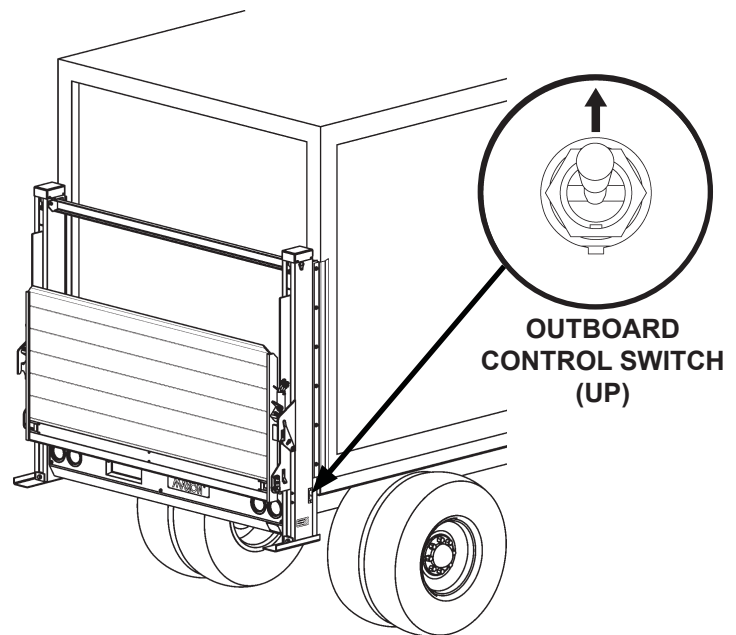

FIG. 15-1

TORSION BAR REPLACEMENT & ADJUSTMENT

REPLACE LH TORSION BAR

WARNING

Ensure platform is latched securely in stowed position to release most tension from torsion bar(s) and keep platform from suddenly unfolding. Injury could result from unbolting the torsion bar(s) under tension. When all tension is released from torsion bar(s), platform can unfold suddenly. Any person in the path of opening platform could be injured.

1. Stow platform (**FIG. 16-1**). Ensure platform is latched securely. Refer to **Operation Manual** for detailed operating instructions.
2. Support platform and flipover evenly by placing supports under the RH and LH runners (**FIG. 16-1**).
3. Remove cap screw and washers from torsion bar pin (**FIG. 16-2**). Initial torsion bar tension is removed when torsion bar pin is in position shown in **FIG. 16-2A**.

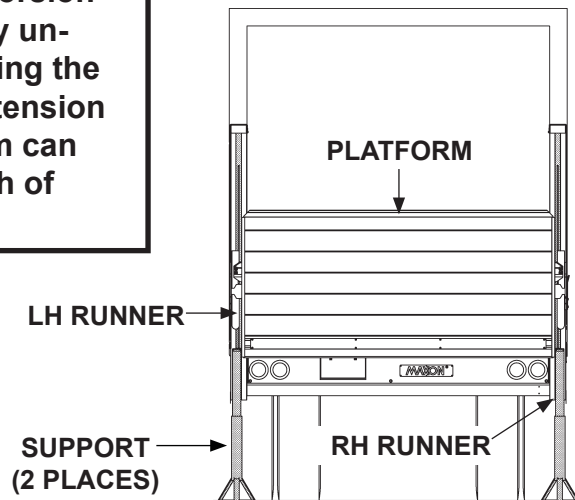

FIG. 16-1

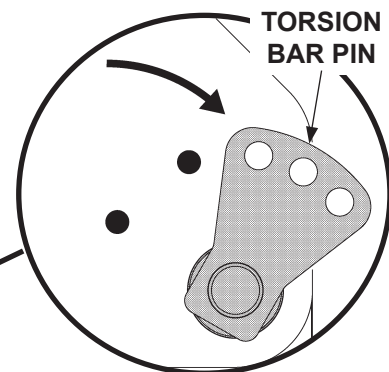
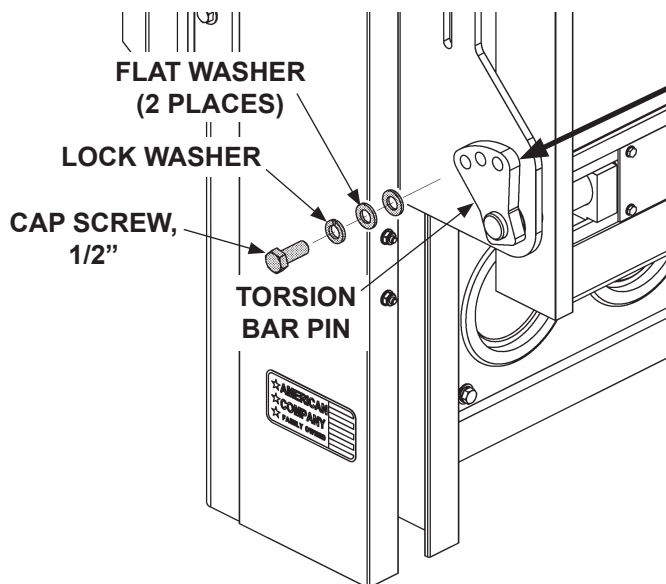

FIG. 16-2A

REMOVING INITIAL TENSION FROM LH TORSION BAR

FIG. 16-2

PERIODIC MAINTENANCE

TORSION BAR REPLACEMENT & ADJUSTMENT - Continued

4. With platform securely supported, remove cover plate (FIG. 17-1).

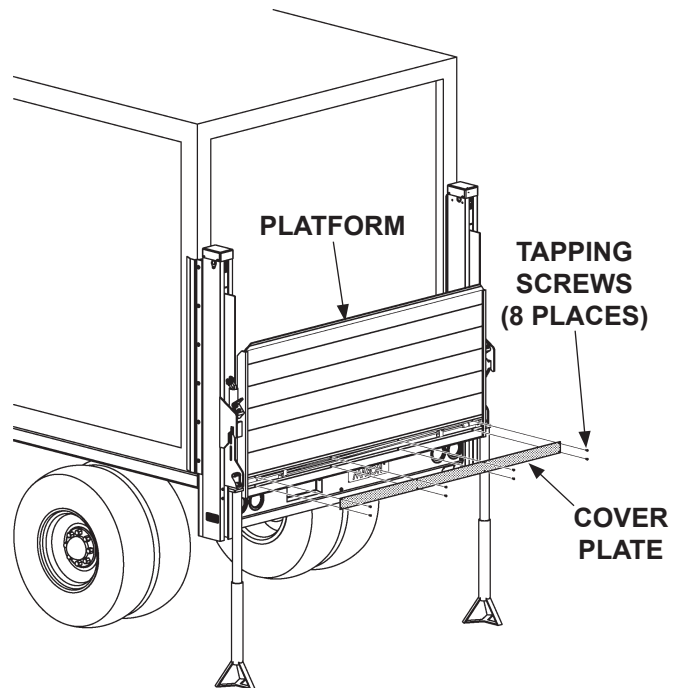

REMOVING COVER PLATE
FIG. 17-1

5. Loosen locking screw from LH torsion bar housing (FIG. 17-2).

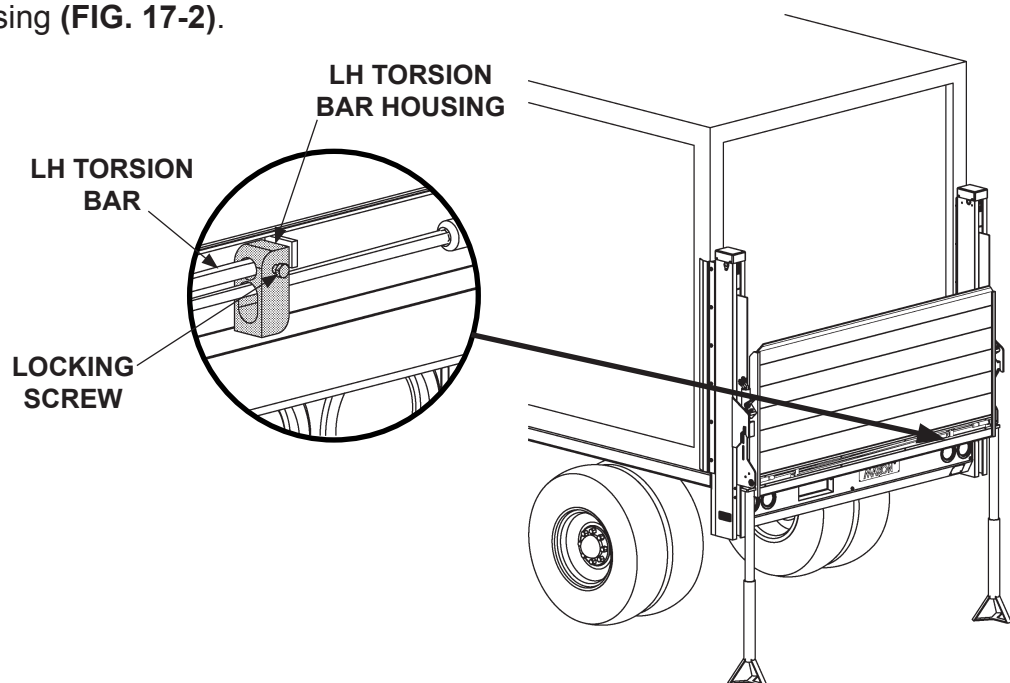
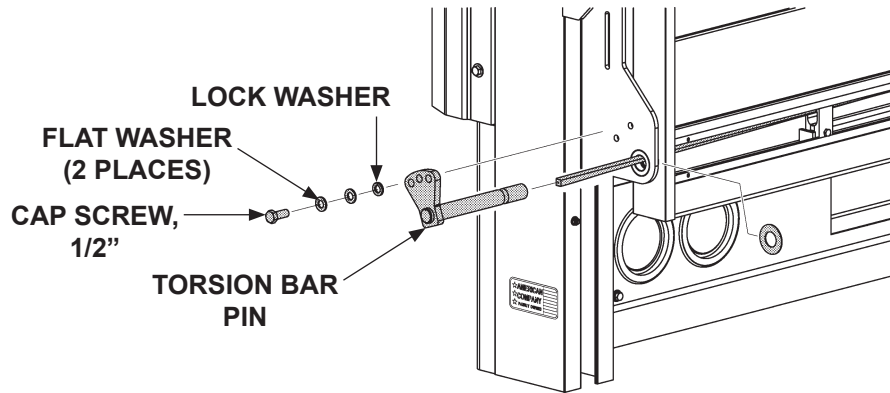

FIG. 17-2

TORSION BAR REPLACEMENT & ADJUSTMENT - Continued

6. Remove LH torsion bar pin (FIG. 18-1).



REMOVING LH TORSION BAR PIN
FIG. 18-1

7. Remove LH torsion bar (FIG. 18-2).

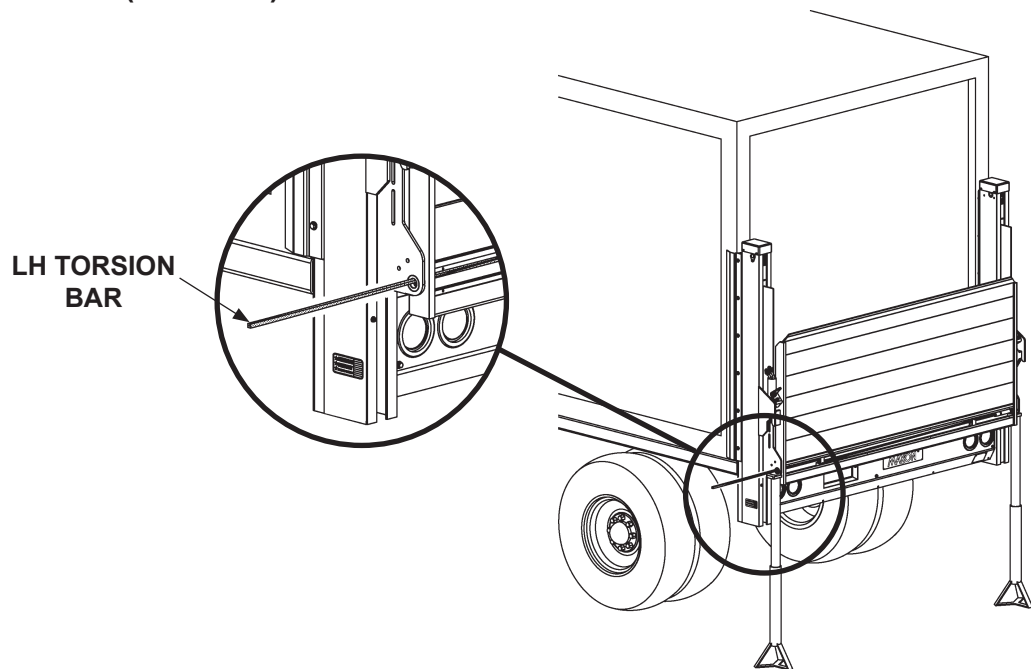

REMOVING LH TORSION BAR
FIG. 18-2

MAXON[®]

11921 Slauson Ave. Santa Fe Springs, CA. 90670 (800) 227-4116 FAX (888) 771-7713

ADJUST LH TORSION BAR

WARNING

Platform can unfold suddenly with no tension on torsion bar. Stay out of the path of unfolding platform when adjusting the torsion bar. Get second person to help unlatch platform.

1. Stow platform. Refer to **Operation Manual** for detailed operating instructions.
2. On LH runner, remove cap screw, lock washer and flat washers from torsion bar pin (**FIG. 19-1**). Adjust the LH torsion bar pin counter-clockwise until tension is applied to torsion bar (**FIG. 19-1A**). Replace cap screw, lock washer and flat washers (**FIG. 19-1**) and tighten.

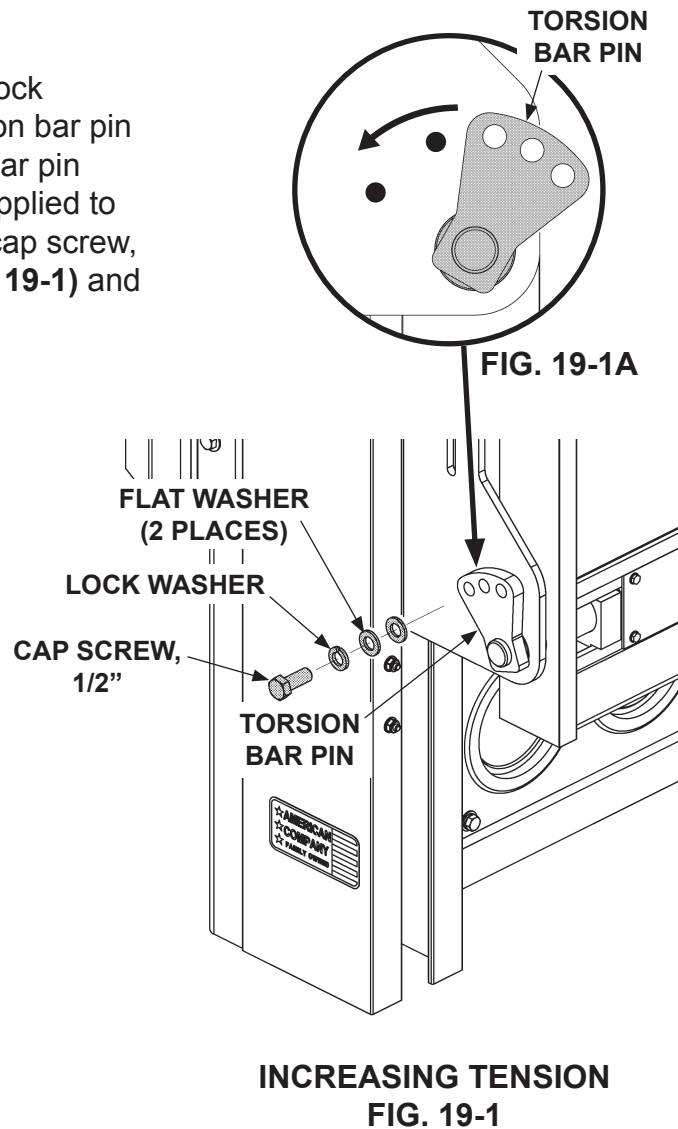

TORSION BAR REPLACEMENT & ADJUSTMENT - Continued

3. Unlatch platform (FIG. 20-1). Platform should just escape the latch as shown in FIG. 20-1, position 1.

4. Unfold platform until latch pin is 2"-3" from latch (FIG. 20-1, position 2). Release hold on platform. Observe If platform starts to fold, stays partially unfolded, or starts falling open with no restraint. Platform should unfold slowly when released (FIG. 20-1, position 3). To increase the amount of pull, adjust the torsion bar pin counter-clockwise until increased tension is applied to torsion bar (FIG. 19-1). Once the platform is unfolded, it should lay flat (FIG. 20-1, position 3). If platform does not lay flat, decrease tension by removing cap screw, lock washer and flat washers from LH torsion bar pin (FIG. 20-2). Adjust torsion bar pin clockwise until tension is decreased (FIG. 20-2A). Replace cap screw, lock washer and flat washers (FIG. 20-2) and tighten.

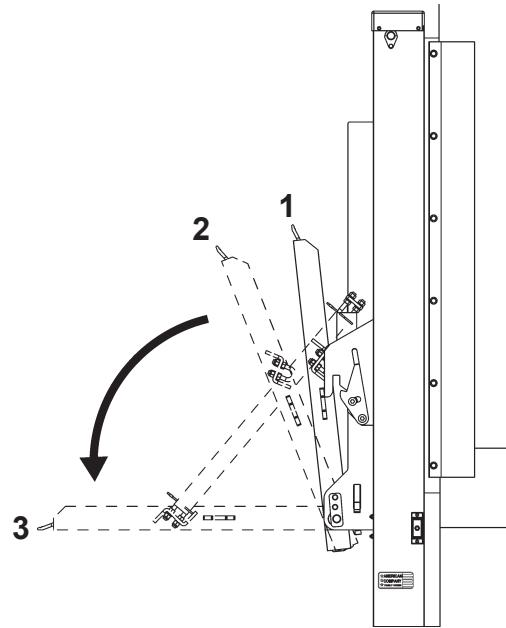
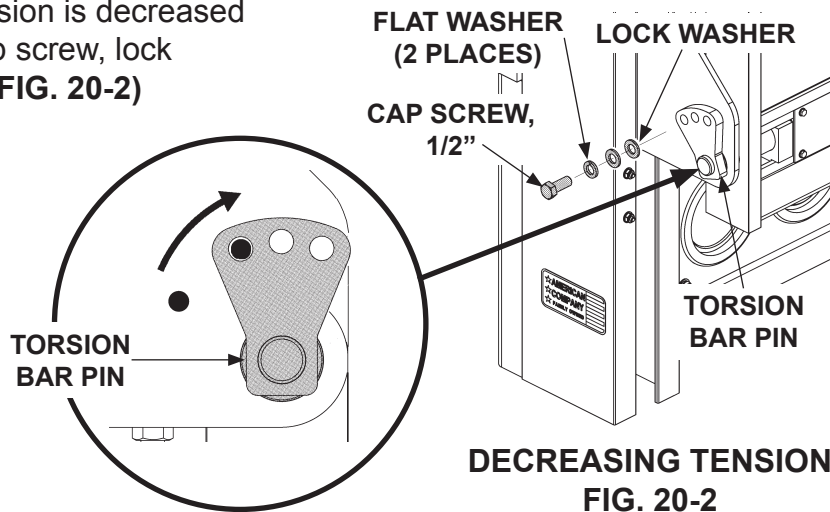

FIG. 20-1



**DECREASING TENSION
FIG. 20-2**

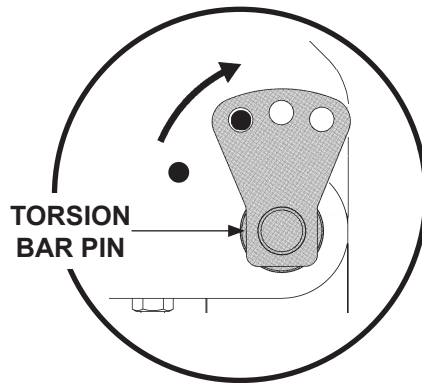

FIG. 20-2A

5. If additional tension is needed, stow platform (FIG. 20-3). Ensure platform is latched securely. Refer to **Operation Manual** for detailed operating instructions.

6. Support platform and flipover evenly by placing supports under the RH and LH runners (FIG. 20-3).

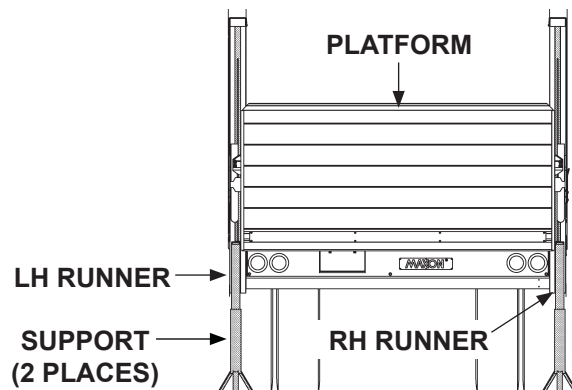
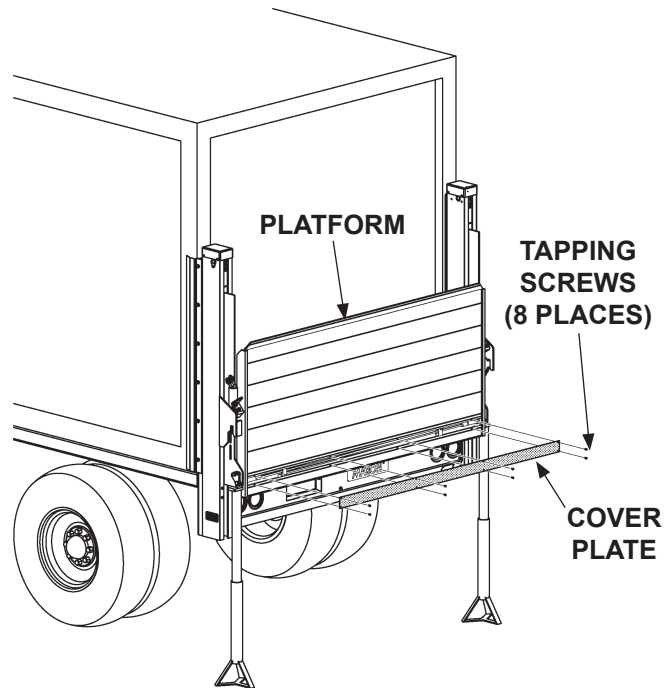

FIG. 20-3

TORSION BAR REPLACEMENT & ADJUSTMENT - Continued

7. With platform securely supported, remove cover plate (**FIG. 21-1**).



REMOVING COVER PLATE
FIG. 21-1

8. Loosen locking screw from LH torsion bar housing (**FIG. 21-2**).

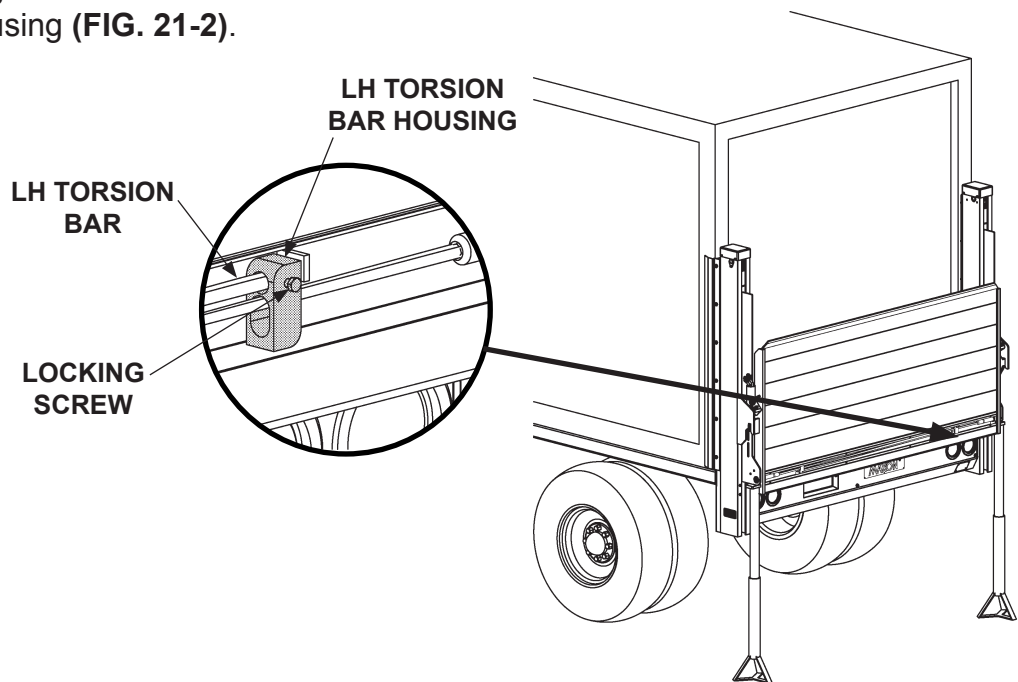
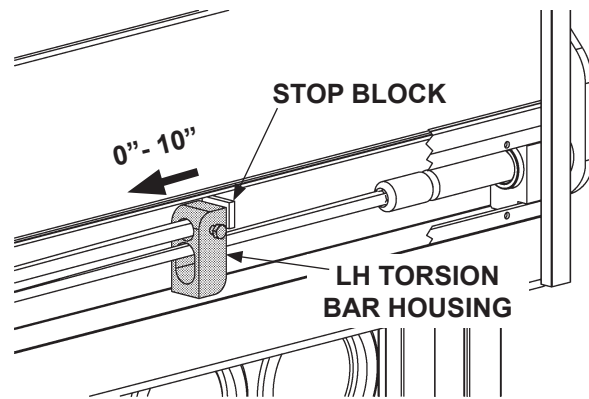

FIG. 21-2

TORSION BAR REPLACEMENT & ADJUSTMENT - Continued

9. Increase LH torsion bar tension by moving LH torsion bar housing inboard towards center of vehicle (**FIG. 22-1**). Approximate adjustment travel should be no more than 10".



**INCREASING LH TORSION BAR TENSION
FIG. 22-1**

10. Replace and tighten LH torsion bar housing locking screw (**FIG. 22-2**).

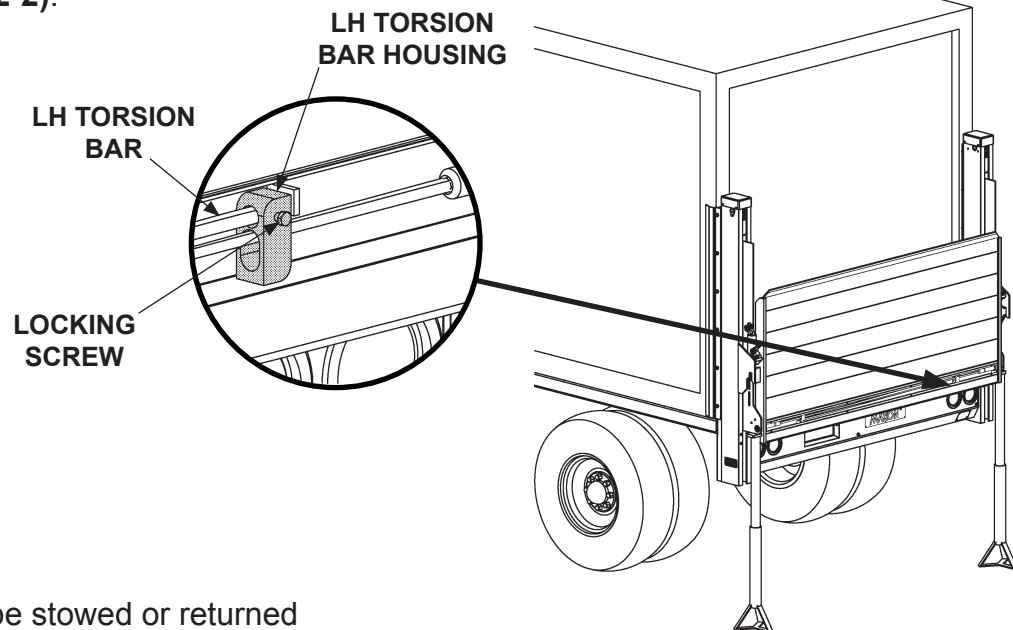

FIG. 22-2

11. Platform can be stowed or returned to operation after adjustment is done correctly.

PERIODIC MAINTENANCE

TORSION BAR REPLACEMENT & ADJUSTMENT - Continued

REPLACE RH TORSION BAR (IF EQUIPPED)

1. Stow platform. Refer to **Operation Manual** for detailed operating instructions.
2. Support platform and flipover evenly by placing supports under the RH and LH runners (**FIG. 23-1**).

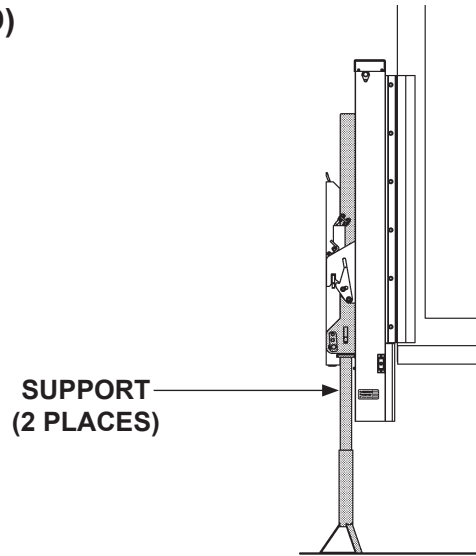
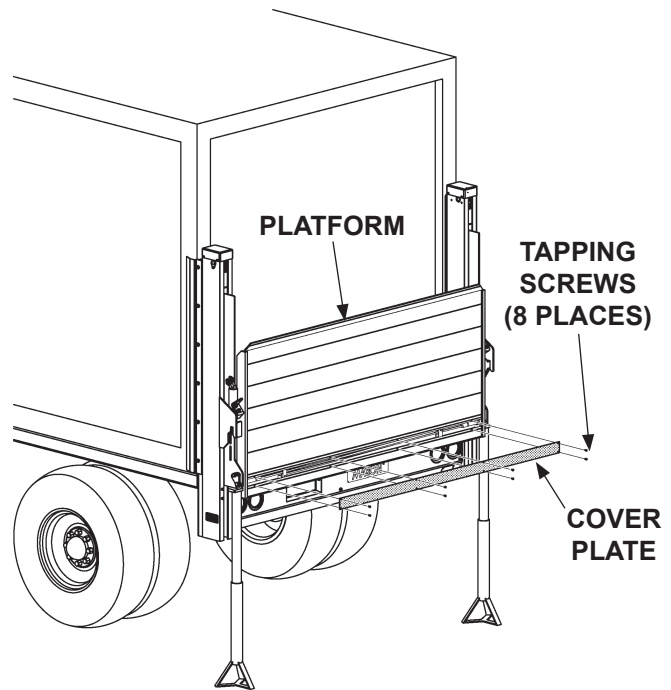

FIG. 23-1

3. With platform securely supported, remove cover plate (**FIG. 23-2**).



REMOVING COVER PLATE
FIG. 23-2

TORSION BAR REPLACEMENT & ADJUSTMENT - Continued

4. Loosen locking screw from RH torsion bar housing (FIG. 24-1).

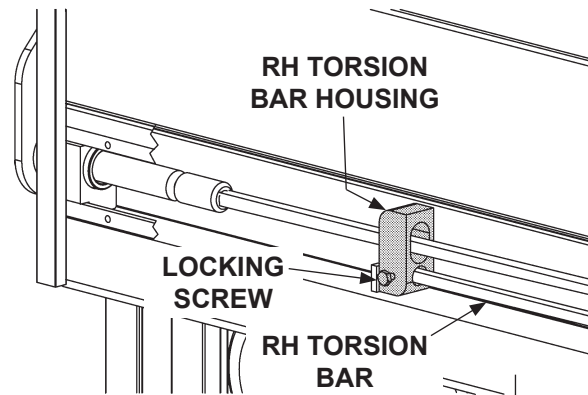

FIG. 24-1

5. On RH runner, unbolt the platform and runner pin from RH runner (FIG. 24-2). Next, remove platform and runner pin, and platform spacer (FIG. 24-2).

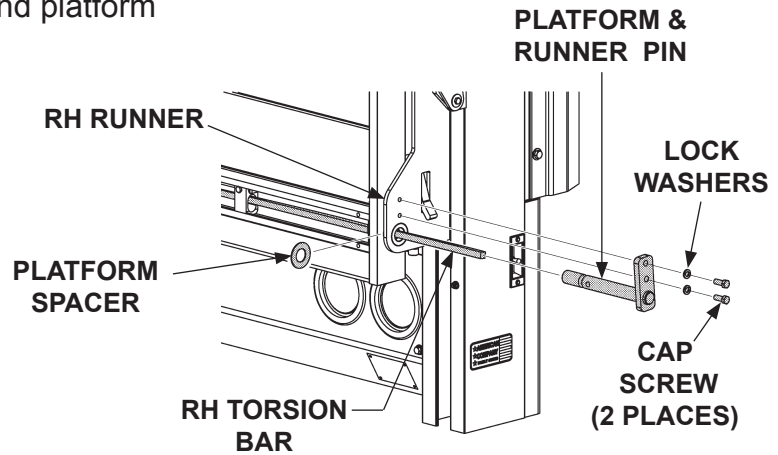
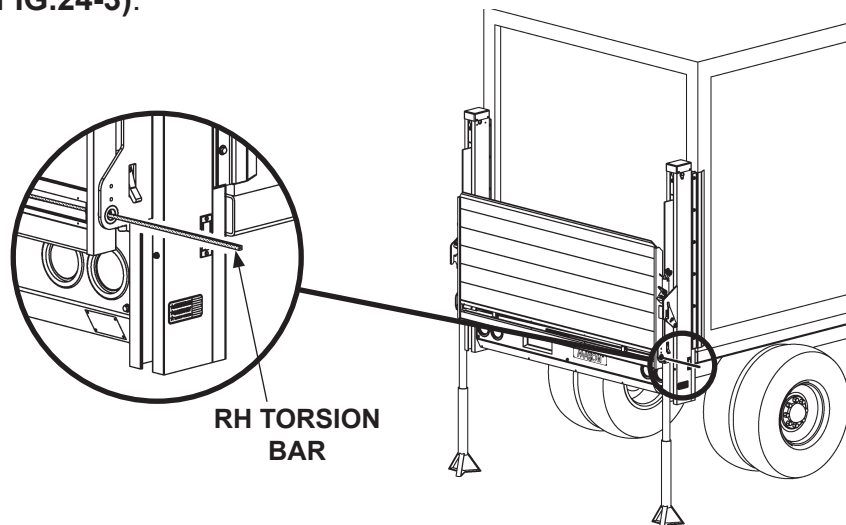

FIG. 24-2

6. Remove RH torsion bar (FIG. 24-3).



REMOVING RH TORSION BAR
FIG. 24-3

TORSION BAR REPLACEMENT & ADJUSTMENT - Continued

7. With platform in vertical position, insert the torsion bar into the RH platform and runner pin, through RH runner, platform spacer and engage with RH torsion bar housing (FIG. 25-1).

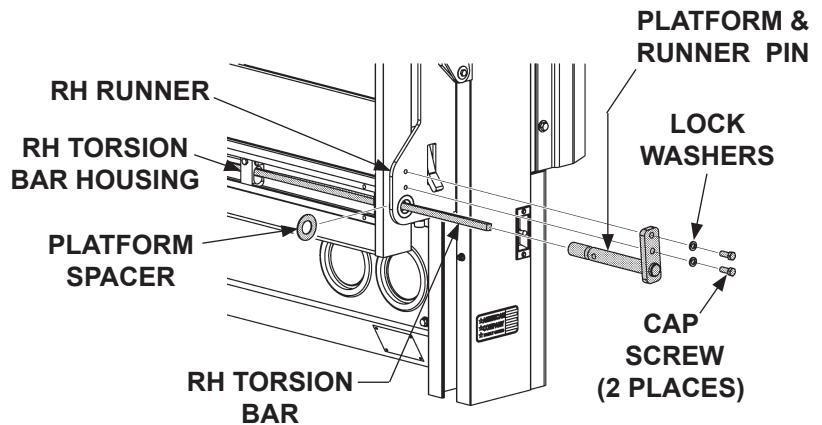

FIG. 25-1

8. Rotate the RH platform and runner pin clockwise to line up the pin holes with the RH runner threaded holes (FIG. 25-2).

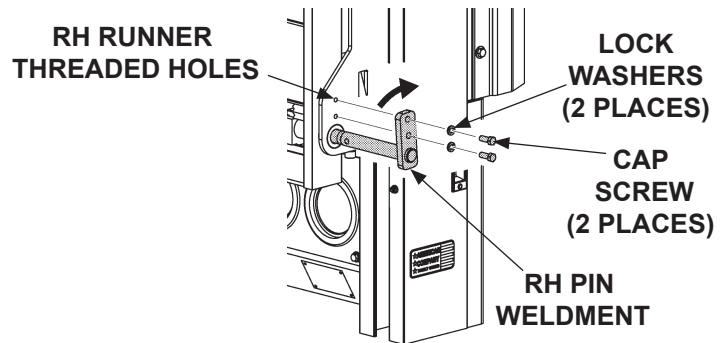

FIG. 25-2

9. Secure RH platform and runner pin as shown in FIG. 25-2.
10. Ensure platform is latched securely in stow position. Then, remove platform supports.

DECALS

NOTE: Decals are preinstalled at factory.
Decal location shown for reference.

NOTE: Ensure there is no residue, dirt or corrosion where decals are attached.
If necessary, clean surface before replacing decals.

THE MAXIMUM CAPACITY OF THIS LIFT IS
2200 LB [1000 KG]
WHEN THE LOAD IS CENTERED ON THE LOAD CARRYING PLATFORM
P/N 220388-03

DMD-22 ONLY
CAPACITY DECAL
P/N 220388-03

THE MAXIMUM CAPACITY OF THIS LIFT IS
3300 LB [1500 KG]
WHEN THE LOAD IS CENTERED ON THE LOAD CARRYING PLATFORM
P/N 220388-02

DMD-33 ONLY
CAPACITY DECAL
P/N 220388-02

- DECAL "E"
- DECAL "D"
- WARNING DECAL
P/N 298373-01
- DECAL "B"
- DECAL "A"
- DECAL "C"



FAMILY OWNED DECAL
P/N 283445-01

Align arrows before folding or unfolding.
P/N 289192-01 (H)

COLUMN ARROW DECAL "H"
P/N 289192-01

RUNNER ARROW DECAL "H"
P/N 289192-01

DECAL "F" OR "G"

WARNING
Liftgate hazards can result in crushing or falling.
Keep hands and feet clear of pinch points.
If riding liftgate, make sure load is stable and footing is solid.

Advertencia
Existe riesgo de caer desde o ser prensado por el elevador.
Mantenga manos y pies fuera de las zonas de pliegue.
Asegúrese de tener la carga estable y usted parado firmemente sobre el elevador.

Read and understand all instructions and WARNINGS before use.
Lee y comprenda todas las instrucciones y ADVERTENCIAS previa operación. P/N 289274-01

WARNING DECAL
P/N 299274-01

MAXON

11921 Slauson Ave. Santa Fe Springs, CA. 90670 (800) 227-4116 FAX (888) 771-7713

SAFETY INSTRUCTIONS

Read all decals and operation manual before operating liftgate.

- Do not use liftgate unless you have been properly instructed and have read, and are familiar with, the operating instructions.
- Be certain vehicle is properly and securely braked before using the liftgate.
- Always inspect this liftgate for maintenance or damage before using it. Do not use liftgate if it shows any sign of damage or improper maintenance.
- Do not overload
- Make certain the area in which the platform will open and close is clear before opening or closing the platform.
- Make certain platform area, including the area in which loads may fall from platform, is clear before and at all times during operation of liftgate.
- This liftgate is intended for loading and unloading of cargo only. Do not use this liftgate for anything but its intended use.

P/N 289192-01 **A**

WARNING

Read this information carefully.

- Improper operation of this Liftgate can result in serious personal injury. If you do not have a copy of the operating instructions, please obtain them from your employer, distributor, or lessor before you attempt to operate Liftgate.
- If there are signs of improper maintenance, damage to vital parts, or slippery platform surface, do not use the Liftgate until these problems have been corrected.
- If you are using a pallet jack, be sure it can be maneuvered safely.
- Do not operate a forklift on the platform.
- Do not allow any part of yours or your helper's body to be placed under, within, or around any portion of the moving Liftgate, or its mechanisms, or in a position that would trap them between the platform and the ground or truck when the Liftgate is operated.
- If a helper is riding the platform with you, make sure you are both doing so safely and that you are not in danger of coming in contact with any moving or potentially moving obstacles.
- USE GOOD COMMON SENSE.**
- If load appears to be unsafe, do not lift or lower it.

For a free copy of other manuals that pertain to this model Liftgate, please visit our website at www.maxonlift.com or call Customer Service at (800) 227-4116. P/N 289192-01 **B**

CAUTION

Always stand clear of platform area.

P/N 289192-01 **E**

P/N 289192-01 **F**

P/N 289192-01 **G**

WARNING

Liftgate hazards can result in crushing or falling.

Keep hands and feet clear of pinch points.

If riding liftgate, make sure load is stable and footing is solid.

Read and understand all instructions and WARNINGS before use.

P/N 289192-01 **D**

Align arrows before folding or unfolding.

P/N 289192-01 **H**

OPERATING INSTRUCTIONS

OPERATE	STOW
<p>RAISE PLATFORM OFF TRANSIT HOOK & LOWER TO UNLOCK.</p> <p style="text-align: right;">1</p>	<p>FOLD & LOCK FLIPOVER IF EQUIPPED.</p> <p style="text-align: right;">1</p>
<p>LOWER PLATFORM AT OR BELOW ARROW ALIGNMENT.</p> <p style="text-align: right;">2</p>	<p>RAISE PLATFORM AT OR BELOW ARROW ALIGNMENT.</p> <p style="text-align: right;">2</p>
<p>RELEASE PLATFORM LOCK & UNFOLD.</p> <p>IF EQUIPPED WITH MANUAL CLOSER (THEN)</p> <p>IF EQUIPPED WITH HYDRAULIC CLOSER (WITH)</p> <p style="text-align: right;">3</p>	<p>RELEASE PLATFORM LOCK & FOLD.</p> <p>IF EQUIPPED WITH MANUAL CLOSER (THEN)</p> <p>IF EQUIPPED WITH HYDRAULIC CLOSER (WITH)</p> <p style="text-align: right;">3</p>
<p>UNLOCK & UNFOLD FLIPOVER IF EQUIPPED.</p> <p style="text-align: right;">4</p>	<p>RAISE PLATFORM ABOVE TRANSIT HOOK.</p> <p style="text-align: right;">4</p>
<p>RAISE / LOWER PLATFORM.</p> <p style="text-align: right;">5</p>	<p>MAKE SURE TRANSIT HOOK RETURNS TO POSITION.</p> <p style="text-align: right;">5</p>

P/N 289192-01 **C**

DECAL SHEET P/N 289192-01

WARNING

A Liftgate extending from a moving vehicle could injure bystanders & damage property. Stow liftgate in correct transit position before moving vehicle.

Advertencia

Un elevador hidráulico abierto en vehículo en movimiento puede ocasionar daños y lesiones a objetos y personas circundantes. Cierre apropiadamente antes de poner el vehículo en movimiento.

P/N 298373-01

**WARNING DECAL
P/N 298373-01**

WARNING

Liftgate hazards can result in crushing or falling.

Keep hands and feet clear of pinch points.

If riding liftgate, make sure load is stable and footing is solid.

Advertencia

Existe riesgo de caer desde o ser prensado por el elevador.

Mantenga manos y pies fuera de las zonas de plegue.

Asegúrese de tener la carga estable y el estante parado firmemente sobre el elevador.

P/N 299274-01

**WARNING DECAL
P/N 299274-01**

SYSTEM DIAGRAMS

PUMP MOTOR & VALVE OPERATION (MANUAL CLOSE)

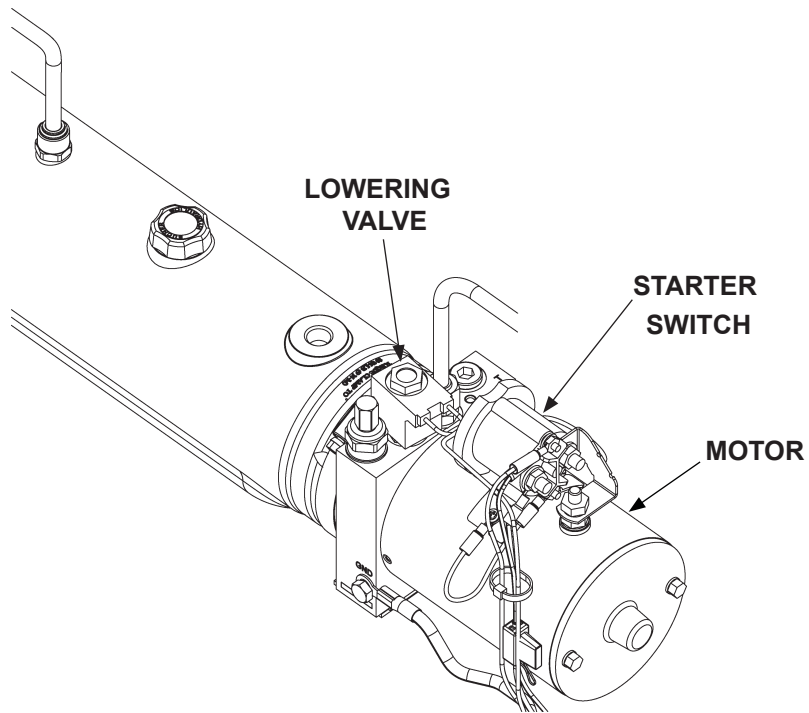

POWER UNIT
FIG. 28-1

POWER UNIT MOTOR & SOLENOID OPERATION		
LIFTGATE FUNCTION	SOLENOID OPERATION (✓ MEANS ENERGIZED)	
	MOTOR STARTER SWITCH	LOWERING VALVE
RAISE	✓	-
LOWER	-	✓
REFER TO VALVES SHOWN ON HYDRAULIC SCHEMATIC		

TABLE 28-1

PUMP MOTOR & VALVE OPERATION (EQUIPPED WITH HYDRAULIC CLOSER)

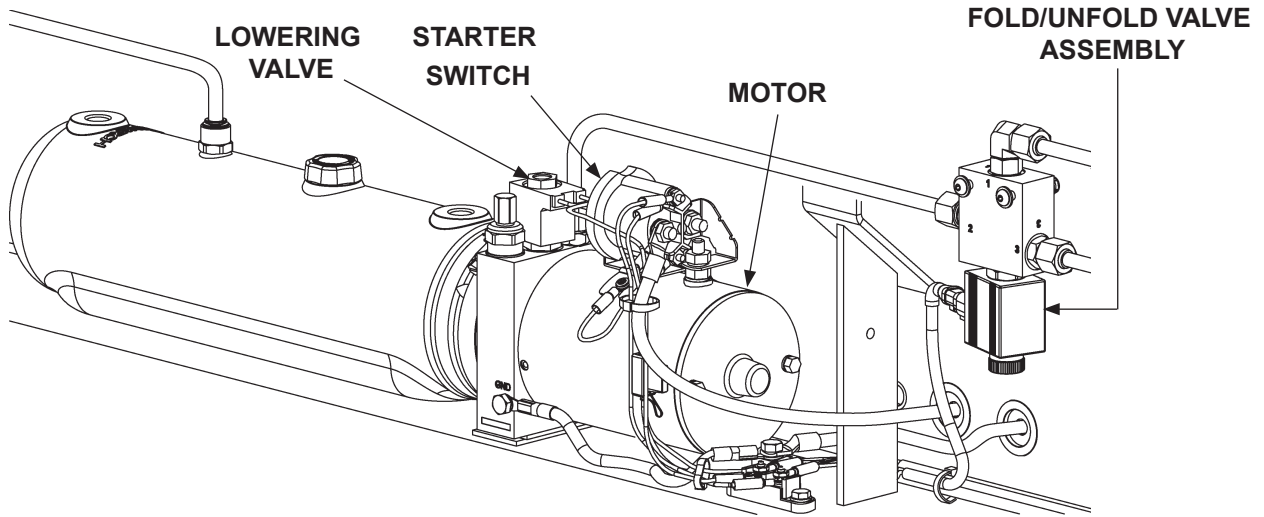

**POWER UNIT
FIG. 29-1**

POWER UNIT MOTOR & VALVE OPERATION			
LIFTGATE FUNCTION	REMOTE VALVE OPERATION (✓ MEANS ENERGIZED)		
	MOTOR	LOWERING VALVE	FOLD/UNFOLD VALVE
RAISE	✓		
LOWER		✓	
UNFOLD		✓	✓
FOLD	✓		✓
REFER TO VALVES SHOWN ON HYDRAULIC SCHEMATIC			

TABLE 29-1

HYDRAULIC SCHEMATIC (MANUAL CLOSE)

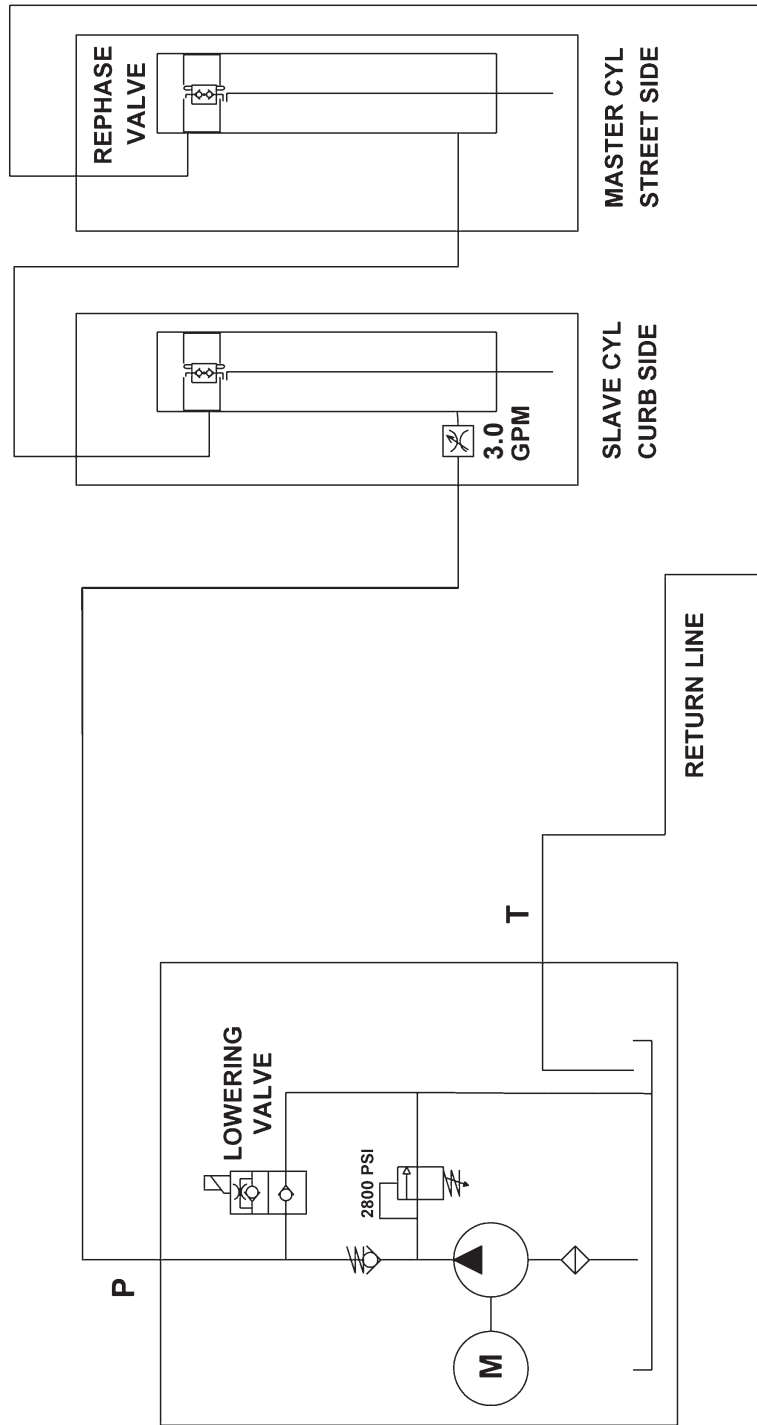

FIG. 30-1

MAXON[®]

11921 Slauson Ave. Santa Fe Springs, CA. 90670 (800) 227-4116 FAX (888) 771-7713

HYDRAULIC SCHEMATIC (EQUIPPED WITH HYDRAULIC CLOSER)

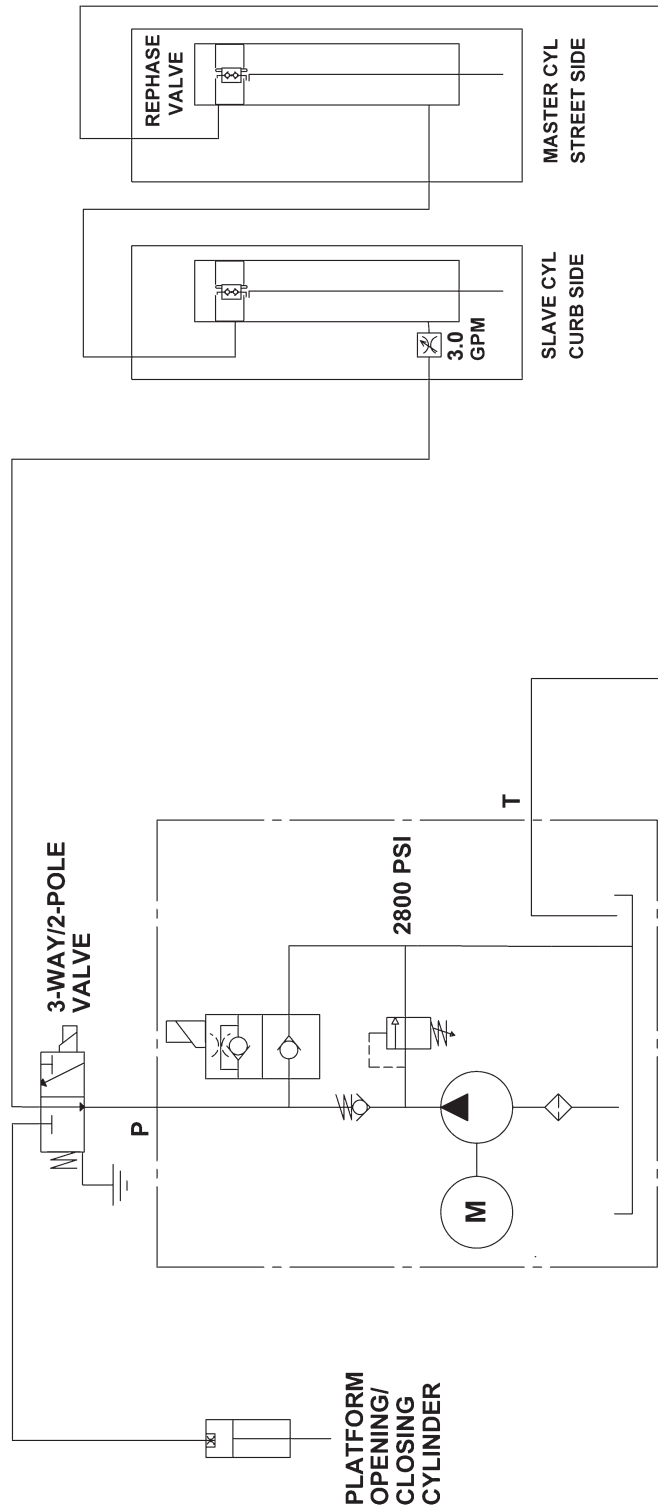

FIG. 31-1

ELECTRICAL SCHEMATIC (MANUAL CLOSE)

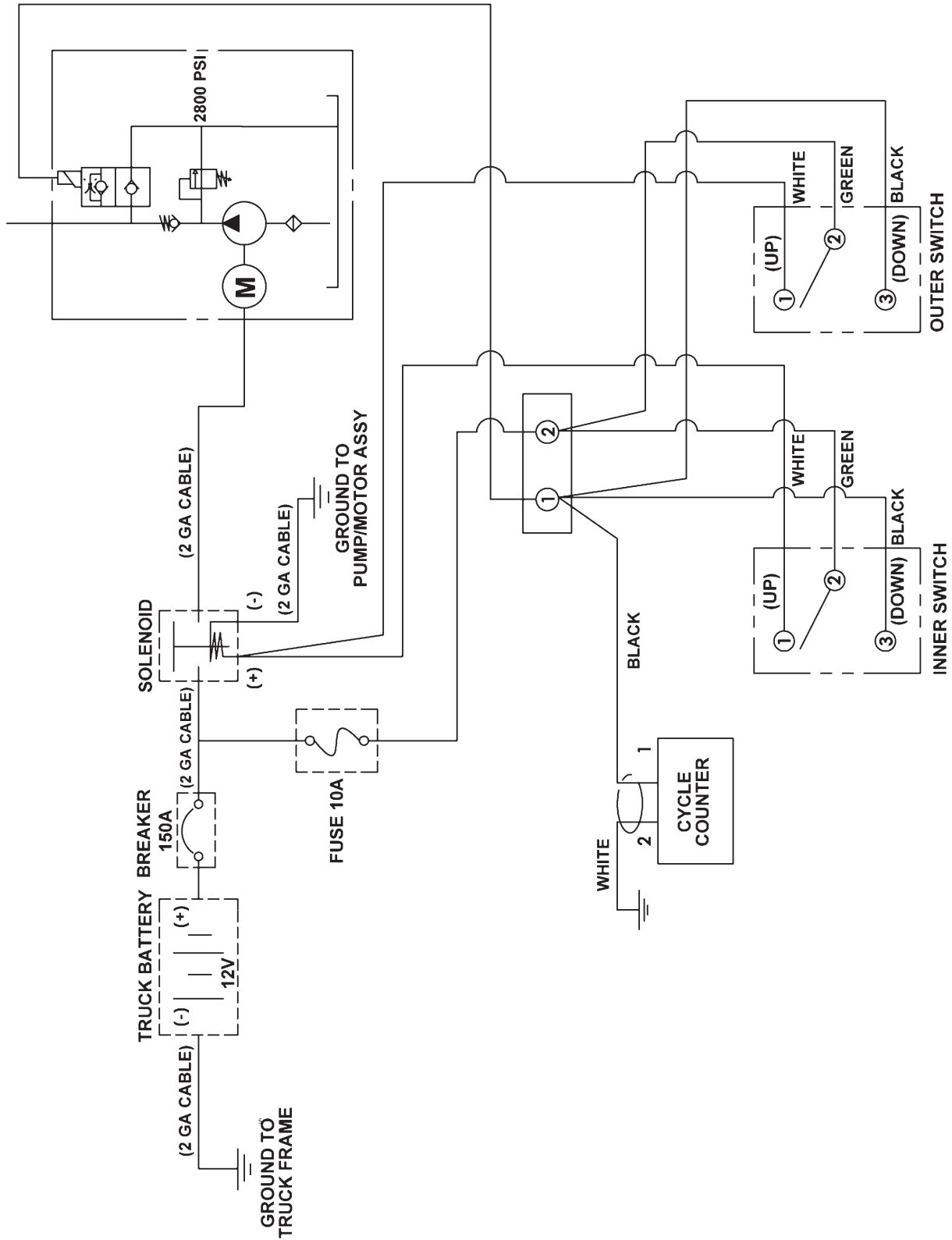

FIG. 32-1

ELECTRICAL SCHEMATIC (EQUIPPED WITH HYDRAULIC CLOSER)

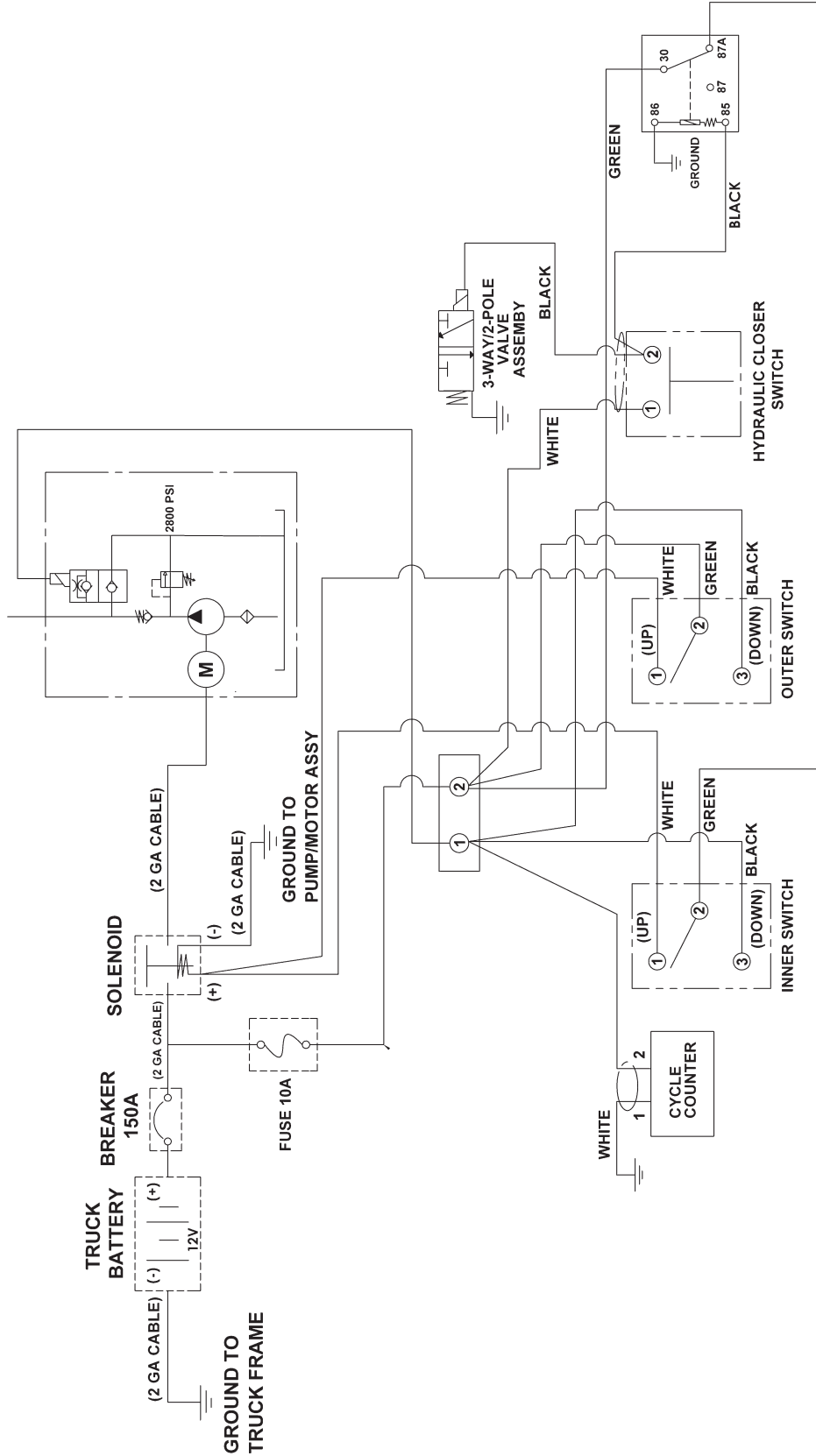
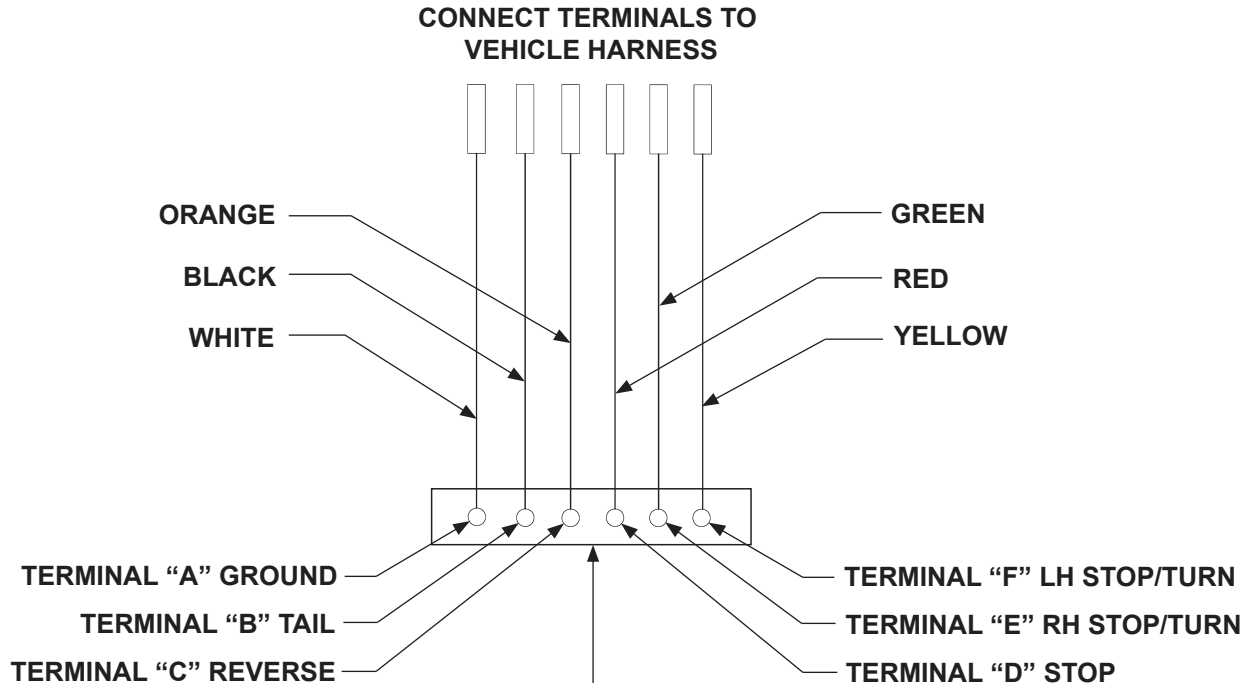

FIG. 33-1

ELECTRICAL SCHEMATIC - JUMPER HARNESS ASSEMBLY

MAXON[®]

11921 Slauson Ave. Santa Fe Springs, CA. 90670 (800) 227-4116 FAX (888) 771-7713



**FOREIGN/DOMESTIC
FIG. 34-1**

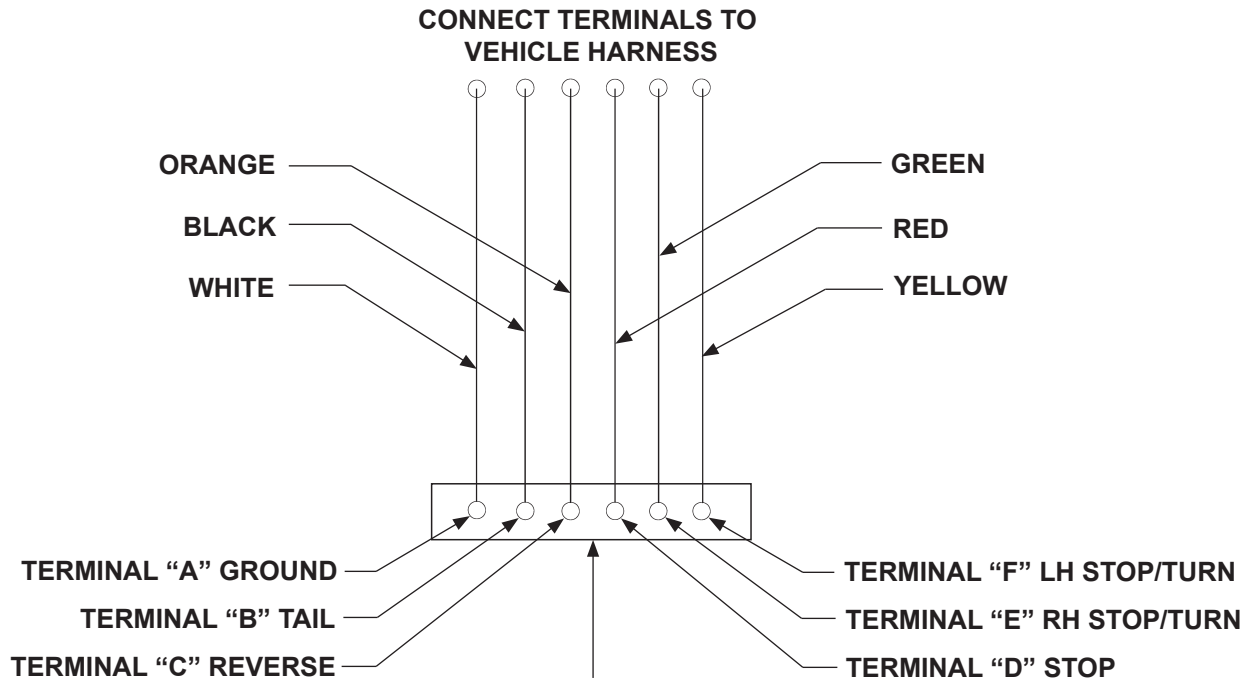

**ISUZU
FIG. 34-2**

SYSTEM DIAGRAMS

ELECTRICAL SCHEMATIC - HOUSING COVER ASSEMBLY (WITHOUT LIGHTS)

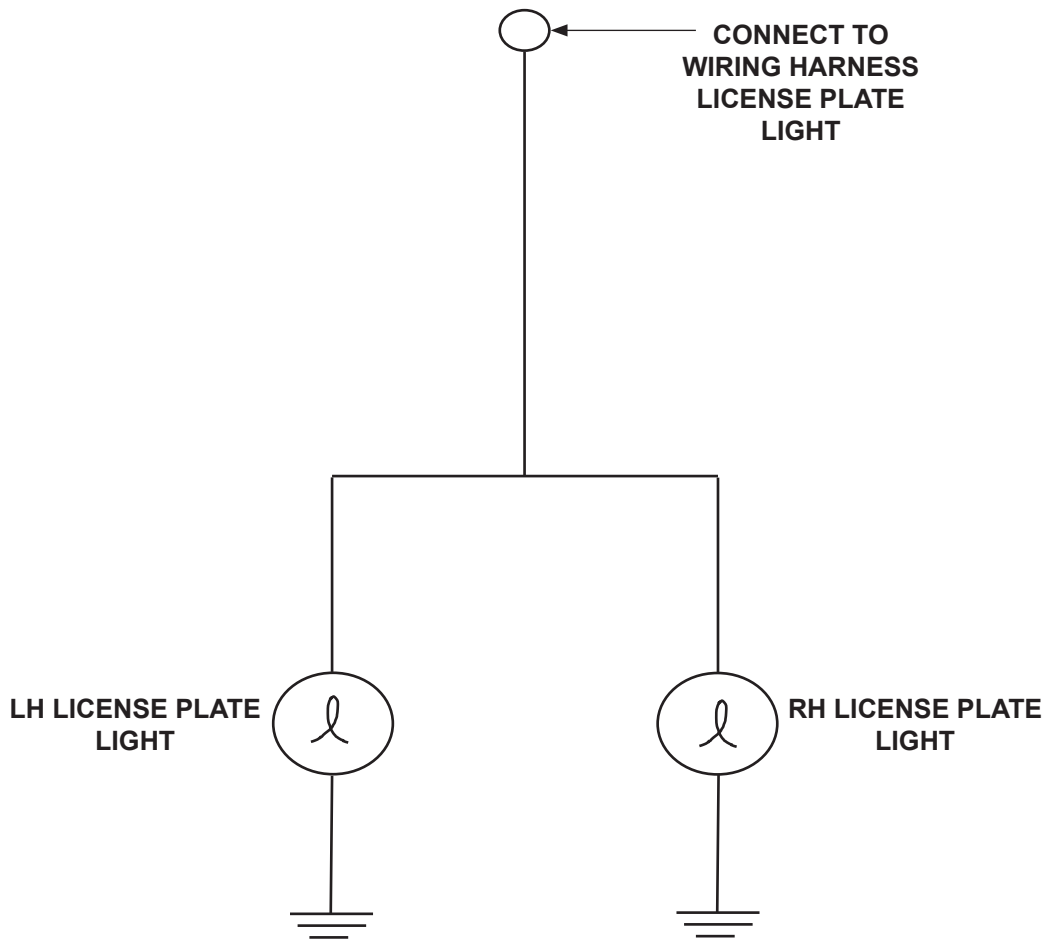
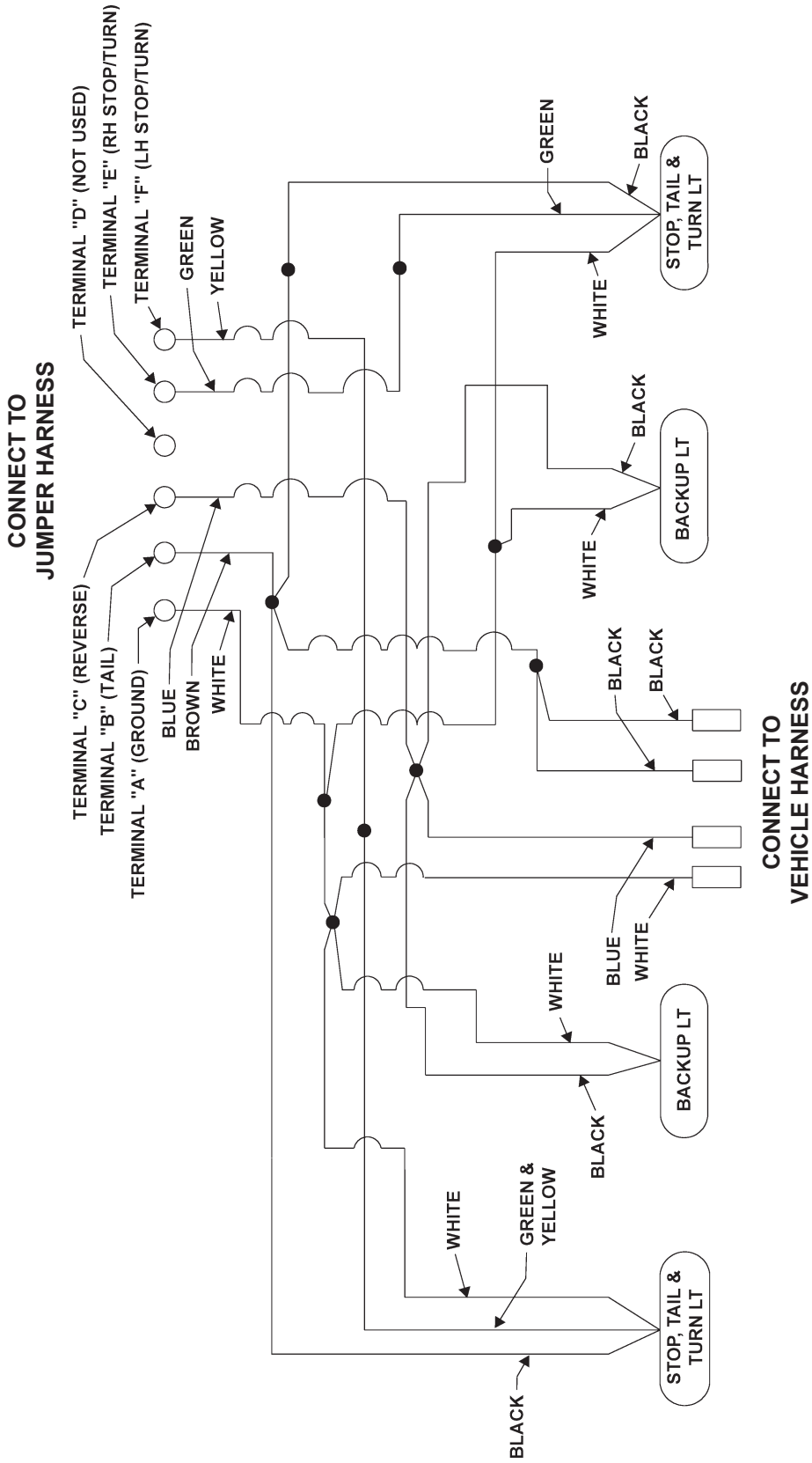

FIG. 35-1

ELECTRICAL SCHEMATIC - HOUSING COVER ASSEMBLY (WITH FOUR LIGHTS)



MAXON[®]

11921 Slauson Ave. Santa Fe Springs, CA. 90670 (800) 227-4116 FAX (888) 771-7713

SYSTEM DIAGRAMS

ELECTRICAL SCHEMATIC - HOUSING COVER ASSEMBLY, FOREIGN VEHICLE (WITH 6 LIGHTS)

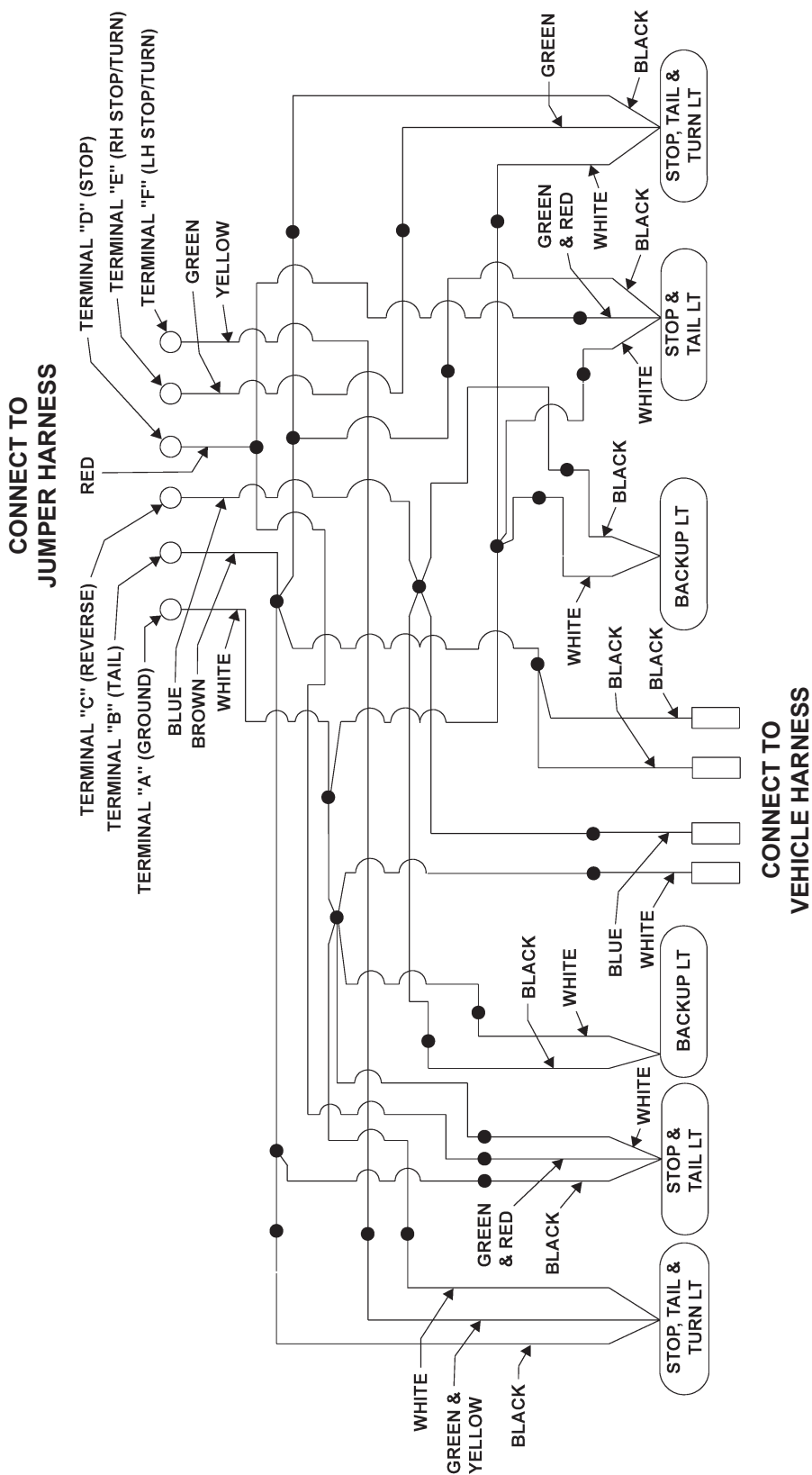

SYSTEM DIAGRAMS DMD ELECTRICAL VALUES

SOLENOID SWITCH	12V	24V
Coil Resistance:	5.4Ω @70°F. ±15%	20.1Ω @70°F. ±15%
Ampere:	2.2A	1.2A
Coil terminal torque: 10-15 lb-in max.		
Contact terminal torque: 30-35 lb-in max.		
LOWERING VALVE		
Coil Resistance:	6.6Ω @ 70°F. ±15%	26.7Ω @ 70°F. ±15%
Ampere:	1.8A	0.9A
Coil terminal torque: 15-45 lb-in max.		
Valve cartridge torque: 25-30 lb-ft max.		
Coil nut torque: 15-45 lb-in		
FOLD/UNFOLD VALVE		
Coil Resistance:	8.0Ω @ 70°F. ±15%	30Ω @ 70°F. ±15%
Ampere:	1.5A	0.8A
Coil terminal torque: 3-4.5 lb-ft max.		
Valve cartridge torque: 18.5-22 lb-ft max.		
GROUND CABLE		
Cap Screw Torque: 24 lb-ft max.		
CYCLE COUNTER		
Operation Voltage:	7V - 30V	7V - 30V

TABLE 38-1

MAXON®

11921 Slauson Ave. Santa Fe Springs, CA. 90670 (800) 227-4116 FAX (888) 771-7713

RECOMMENDED BOLT TORQUES

CAUTION

The torque values in the following table are provided for torquing grade 8 bolts on Liftgate mechanical parts. To prevent damage, never use the information in this table for torquing electrical or hydraulic hose connections on the pump assembly.

GRADE 8 BOLT TIGHTENING TORQUE	
DIAMETER & THREAD PITCH	TORQUE
1/4"-20	10-14 lb-ft
1/4"-28	11-16 lb-ft
5/16"-18	20-29 lb-ft
5/16"-24	22-33 lb-ft
3/8"-16	35-52 lb-ft
3/8"-24	40-59 lb-ft
7/16"-14	56-84 lb-ft
7/16"-20	62-93 lb-ft
1/2"-13	85-128 lb-ft
1/2"-20	96-144 lb-ft
9/16"-12	123-184 lb-ft
9/16"-18	137-206 lb-ft
5/8"-11	170-254 lb-ft
5/8"-18	192-288 lb-ft
3/4"-10	301-451 lb-ft
3/4"-18	336-504 lb-ft

TABLE 39-1

