

M-20-09
REV. A
DECEMBER 2020

MAXON®

MXT-25 & MXT-33

INSTALLATION MANUAL

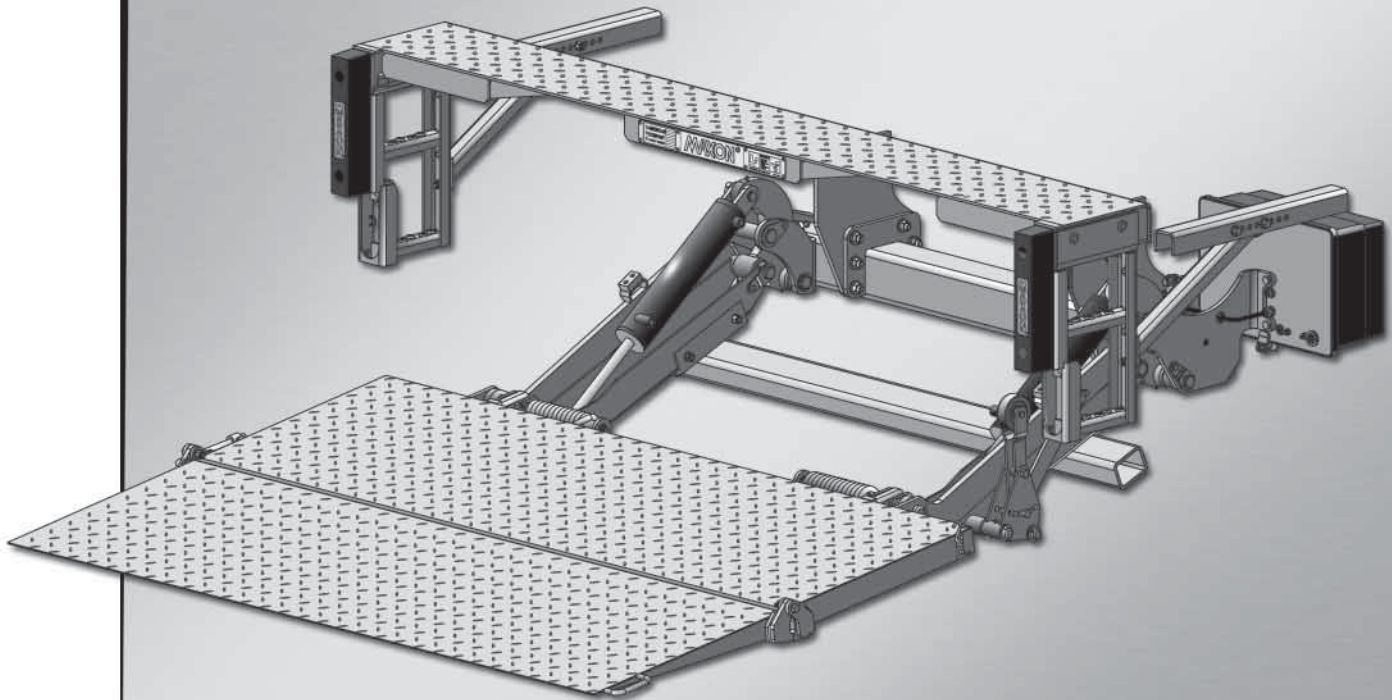
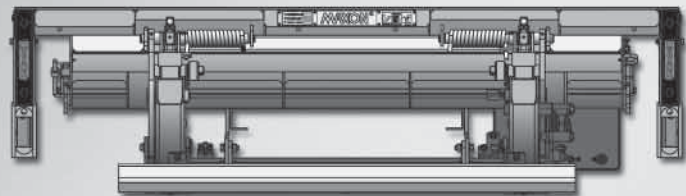

To find maintenance & parts information for your **MXT-25** or **MXT-33** Liftgate, go to www.maxonlift.com. Click the **PRODUCTS**, **TUK-A-WAY** and **MXT-25/MXT-33** buttons. Open the **Maintenance Manual** in the **PRODUCT DOCUMENTATION** window. For parts, click on the **PARTS PORTAL**, **TUK-A-WAY** and **MXT-25/MXT-33** buttons.

TABLE OF CONTENTS

SUMMARY OF CHANGES: M-20-09, REVISION A	4
WARNINGS	5
SAFETY INSTRUCTIONS	6
NOTICE	6
STANDARD LIFTGATE COMPONENTS	7
MXT-25 & MXT-33 INSTALLATION PARTS BOXES.....	8
MXT-25 & MXT-33 MANUALS & DECALS.....	9
VEHICLE REQUIREMENTS	10
CENTER OF MASS	12
STEP 1 - ATTACH EXTENSION PLATE TO VEHICLE	13
BOLT EXTENSION PLATE.....	13
WELD EXTENSION PLATE (ALTERNATE METHOD).....	16
STEP 2 - WELD LIFTGATE TO VEHICLE	18
STEP 3 - ATTACH OPTIONAL BATTERY BOX & FRAME TO VEHICLE (IF EQUIPPED) ..	22
STEP 4 - RUN POWER CABLE.....	30
STEP 5 - CONNECT POWER CABLE.....	32
STEP 6 - CONNECT GROUND CABLE	34
STEP 7 - INSTALL CONTROL SWITCH	36
STEP 8 - CHECKING HYDRAULIC FLUID.....	39
STEP 9 - CONNECT POWER CABLE TO BATTERY.....	41
STEP 10 - REMOVE LOCKING BRACKETS & CHECK FOR INTERFERENCE	42
STEP 11 - ADJUST PLATFORM OPENER.....	48
STEP 12 - ADJUST PLATFORM (IF REQUIRED)	49
STEP 13 - FINISH WELDING LIFTGATE TO VEHICLE	51
STEP 14 - BOLT OPTIONAL STEPS TO EXTENSION PLATE	52
STEP 15 - VEHICLE TAILLIGHT POSITIONING	57
ATTACH DECALS: MXT-25 & MXT-33	58

TABLE OF CONTENTS - Continued

DECALS & PLATES	60
TOUCHUP GALVANIZED FINISH	61
SYSTEM DIAGRAMS	62
PUMP & MOTOR SOLENOID OPERATION (GRAVITY DOWN).....	62
HYDRAULIC SCHEMATIC (GRAVITY DOWN).....	63
ELECTRICAL SCHEMATIC (GRAVITY DOWN)	64
PUMP & MOTOR SOLENOID OPERATION (POWER DOWN).....	65
HYDRAULIC SCHEMATIC (POWER DOWN)	66
ELECTRICAL SCHEMATIC (POWER DOWN).....	67
PUMP & MOTOR SOLENOID OPERATION WITH MAX ECU MODULE (GRAVITY DOWN)	68
HYDRAULIC SCHEMATIC WITH MAX ECU MODULE (GRAVITY DOWN).....	69
ELECTRICAL SCHEMATIC WITH MAX ECU MODULE (GRAVITY DOWN)	70
PUMP & MOTOR SOLENOID OPERATION WITH MAX ECU MODULE (POWER DOWN).....	71
HYDRAULIC SCHEMATIC WITH MAX ECU MODULE (POWER DOWN)	72
ELECTRICAL SCHEMATIC WITH MAX ECU MODULE (POWER DOWN)	73
ELECTRICAL VALUES & TORQUE SPECIFICATIONS	74
OPTIONS	75
OPTIONAL LIFTGATE COMPONENTS.....	75
PRE-DELIVERY INSPECTION FORM.....	77

SUMMARY OF CHANGES: M-20-09, REVISION A

PAGE	DESCRIPTION OF CHANGE
COVER	Updated REV. and date of release.
10	Changed dimensions for 38" - 46" bed height clearances.
11	Changed dimensions for platform cutout area. Added Note to check with body manufacturer before modifying rear sill and for best practices to reinforce cutout areas in rear sill.
12	Changed dimensions for center of mass.
21	Mounting plates are larger and changed shape.
24	Updated instruction to clarify battery box hanger bracket weld on option.
29	Identified ground cable from vehicle battery in FIG. 29-1.
36	Changed drill bit size from #21 drill bit to 5/32" drill bit for drilling 2 holes in vehicle body vertical post.
47	Added maximum allowable side to side difference is 1/4" across the width of the platform.
48	Platform opener changed to six holes for adjustment. Updated bolt hole chart.
63, 69	Updated hydraulic schematics for GD. Removed optional PCFC.
65	Added Off Time Delay Module to power down power unit and Table 65-1.
71	Added Off Time Delay Module to power down power unit with MAX ECU Module and Table 71-1.
64, 67, 70, 73	Added 12 V or 24 V battery to electrical schematics.
67, 73	Added Off Time Delay Module to power down electrical schematics.
77	Updated times to lower/raise platform.

Comply with the following **WARNINGS** and **SAFETY INSTRUCTIONS** while installing Liftgates. See Operation Manual for operating safety requirements.

WARNING

Installing and maintaining a liftgate can expose you to chemicals, including lead, which are known to the State of California to cause cancer and birth defects or other reproductive harm. To minimize exposure, install and maintain liftgate in a well-ventilated area and wear **proper Personal protective equipment (PPE)**. For more information go to www.P65Warnings.ca.gov.

WARNING

- Do not stand, or allow obstructions, under the platform when lowering the Liftgate. **Be sure your feet are clear of the Liftgate.**
- **Keep fingers, hands, arms, legs, and feet clear of moving Liftgate parts (and platform edges) when operating the Liftgate.**
- **Correctly stow platform when not in use. Extended platforms could create a hazard for people and vehicles passing by.**
- **Make sure vehicle battery power is disconnected** while installing Liftgate. Connect vehicle battery power to the Liftgate only when installation is complete or as required in the installation instructions.
- If it is necessary to stand on the platform while operating the Liftgate, keep your feet and any objects clear of the inboard edge of the platform. Your feet or objects on the platform can become trapped between the platform and the Liftgate extension plate.
- Never perform unauthorized modifications on the Liftgate. Modifications may result in early failure of the Liftgate and may create hazards for Liftgate operators and maintainers.
- Recommended practices for welding on steel parts are contained in the current **AWS (American Welding Society) D1.1 Structural Welding Code - Steel**. Damage to Liftgate and/or vehicle, and personal injury can result from welds that are done incorrectly.
- Recommended practices for welding galvanized steel are contained in the current **AWS (American Welding Society) D19.0 Welding Zinc-Coated Steel**. Damage to Liftgate and/or vehicle, and personal injury can result from welds that are done incorrectly.

SAFETY INSTRUCTIONS

- Read and understand the instructions in this **Installation Manual** before installing Liftgate.
- Before operating the Liftgate, read and understand the operating instructions in **Operation Manual**.
- Comply with all **WARNING** and instruction decals attached to the Liftgate.
- Keep decals clean and legible. If decals are illegible or missing, replace them. Free replacement decals are available from **Maxon Customer Service**.
- Consider the safety and location of bystanders and location of nearby objects when operating the Liftgate. Stand to one side of the platform while operating the Liftgate.
- Do not allow untrained persons to operate the Liftgate.
- Wear appropriate safety equipment such as protective eyeglasses, faceshield and clothing while performing maintenance on the Liftgate and handling the battery. Debris from drilling and contact with battery acid may injure unprotected eyes and skin.
- Be careful working by an automotive type battery. Make sure the work area is well ventilated and there are no flames or sparks near the battery. Never lay objects on the battery that can short the terminals together. If battery acid gets in your eyes, immediately seek first aid. If acid gets on your skin, immediately wash it off with soap and water.
- If an emergency situation arises (vehicle or Liftgate) while operating the Liftgate, release the control switch to stop the Liftgate.
- A correctly installed Liftgate operates smoothly and reasonably quiet. The only noticeable noise during operation comes from the power unit while the platform is raised and lowered. Listen for scraping, grating and binding noises and correct the problem before continuing to operate Liftgate.

NOTICE

- Maxon Lift is responsible for the instructions to correctly install **MAXON** Liftgates on trucks or trailers only.
- Liftgate installers, not Maxon Lift, are responsible for reviewing and complying with all applicable Federal, State, and Local regulations pertaining to the trailer or truck.
- Installers of the liftgate should ensure that all trucks and trailers are equipped with grab handles as needed. Refer to Technology Maintenance Council (TMC) RP 1428: Entry and Egress Guidelines for Vehicles With Fold-Under Type Liftgates.

STANDARD LIFTGATE COMPONENTS

⚠ CAUTION

Unpacking the Liftgate on unlevel surface may allow heavy components to slide off when shipping bands are cut. Injury and equipment damage could result. Before the shipping bands are cut, put Liftgate on level asphalt, concrete or compacted dirt surface that will support 1500 lb. When unpacking the Liftgate, remove heavy components carefully to avoid injury and damage.

NOTE: Make sure you have all components and parts before you start installing Liftgate. Compare parts in the part box and each kit box with packing list enclosed in each box. If parts and components are missing or incorrect, call:

Maxon Customer Service

Call (800) 227-4116 or

Send e-mail to cservice@maxonlift.com

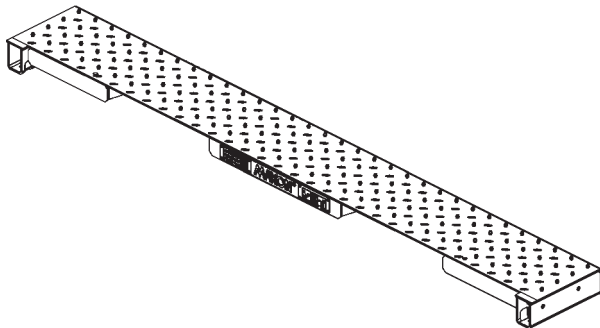

EXTENSION PLATE

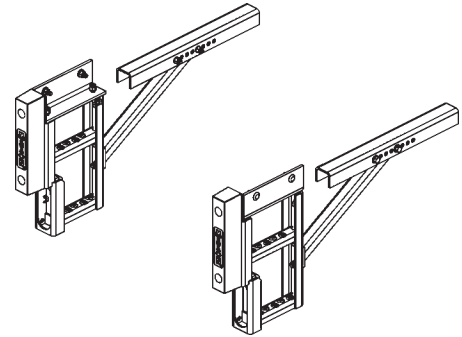

DUAL STEP KIT

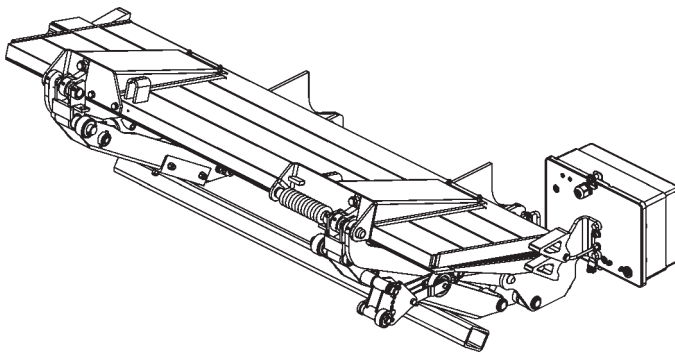

MXT-25 OR MXT-33 LIFTGATE

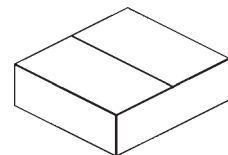

PARTS BOX B

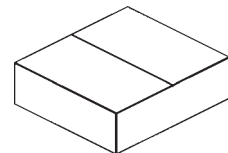

PARTS BOX A OR C

LIFTGATE COMPONENTS

FIG. 7-1

11921 Slauson Ave. Santa Fe Springs, CA. 90670 (800) 227-4116 FAX (888) 771-7713

MAXON

MXT-25 & MXT-33 INSTALLATION PARTS BOXES

ITEM	NOMENCLATURE OR DESCRIPTION	QTY.	PART NUMBER
REF	PARTS BOX A	1	297502-01
1	SPRING CLIP	10	050079
2	PLASTIC TIE, 12-14"	2	206864
3	#10 LOOM CLAMP	2	801681
4	SCREW TAPPING #10 X 1/2" LG.	2	030458
5	CABLE ASSEMBLY, 2 GA, 48" LG.	1	251871-26
6	CABLE ASSEMBLY, 175 AMPS, 38' LG.	1	264422
7	CAP SCREW, 5/16"-18 X 3/4" LG, GR8	1	900009-3
8	CABLE ASSEMBLY, 2 GA, 49-3/4" LG	1	268226-11

**CONTENTS OF PARTS BOX A
TABLE 8-1**

ITEM	NOMENCLATURE OR DESCRIPTION	QTY.	PART NUMBER
REF	PARTS BOX B	1	297049-01
1	TOGGLE SWITCH ASSEMBLY	1	296855-01
2	HEX NUT, 1/2"-13	2	901011-9
3	HEX HEAD CAP SCREW, 1/2"-13 X 1-1/2" LG.	2	900035-3
4	INSTALLATION BRACKET	2	269462-01
5	SCREW, SELF TAPPING, #10-24 X 1-1/2" LG.	2	900057-7
6	LUG, 2 GA COPPER	1	906497-02

**CONTENTS OF PARTS BOX B
TABLE 8-2**

ITEM	NOMENCLATURE OR DESCRIPTION	QTY.	PART NUMBER
REF	PARTS BOX C	1	297502-02
1	SPRING CLIP	20	050079
2	PLASTIC TIE, 12-14"	4	206864
3	GROMMET, 1" DIAMETER, 2 HOLES	1	266428-09
4	CABLE ASSEMBLY, 175 AMP 38' LG.	1	264422
5	GROUND CABLE ASSEMBLY, 2 GA X 38' LG.	1	269191-01
6	SCREW TAPPING #10 X 1/2" LG.	2	030458
7	#10 LOOM CLAMP	2	801681
8	CAP SCREW, 5/16"-18 X 3/4" LG, GR8	1	900009-3
9	CABLE ASSEMBLY, 2 GA, 49-3/4" LG	1	268226-11

**CONTENTS OF PARTS BOX C
TABLE 8-3**

MXT-25 & MXT-33 MANUALS & DECALS

To find maintenance and parts information for your **MXT-25** or **MXT-33 Liftgate**, go to www.maxonlift.com. Click the **PRODUCTS**, **TUK-A-WAY** and **MXT-25/MXT-33** buttons. Open the **Maintenance Manual** in the **PRODUCT DOCUMENTATION** window. For parts, click on the **PARTS PORTAL**, **TUK-A-WAY** and **MXT-25/MXT-33** buttons.

ITEM	NOMENCLATURE OR DESCRIPTION	QTY.	PART NUMBER
REF	MXT-25 MANUAL & DECAL KIT	1	283770-01
1	INSTALLATION MANUAL	1	M-20-09
2	OPERATION MANUAL	1	M-20-10
3	DECALS (SEE DECAL PAGES IN THIS MANUAL)	1	220382
			285800-05
			299038-01
			282522-01
			282847-02
			298634-01
			299348-09

**MXT-25 STANDARD KIT
TABLE 9-1**

ITEM	NOMENCLATURE OR DESCRIPTION	QTY.	PART NUMBER
REF	MXT-33 MANUAL & DECAL KIT	1	283770-02
1	INSTALLATION MANUAL	1	M-20-09
2	OPERATION MANUAL	1	M-20-10
3	DECALS (SEE DECAL PAGES IN THIS MANUAL)	1	220388-02
			285800-05
			299038-01
			282522-01
			282847-02
			298634-01
			299348-09

**MXT-33 STANDARD KIT
TABLE 9-2**

VEHICLE REQUIREMENTS

NOTE: Maximum and Minimum Operating Bed Height for Standard Platforms:

- Maximum bed height for MXT-25 and MXT-33 Liftgates on low bed vehicles is **46"** (unloaded). Minimum bed height on low bed vehicles is **38"** (loaded). See **MXT-25 and MXT-33 LOW BED CLEARANCES, FIGS. 10-1 and 10-1A.**
- If swing door latches interfere with fit of extension plate, do not install this Liftgate on vehicle bodies equipped with **swing open doors.**

NOTE: Dimensions are provided as reference for fitting Liftgate to vehicle body.

NOTE: Make sure vehicle is parked on level ground while preparing vehicle and installing Liftgate.

1. Check for correct clearances on vehicle (**FIGS. 10-1 and 10-1A**) to prevent interference between vehicle and Liftgate.

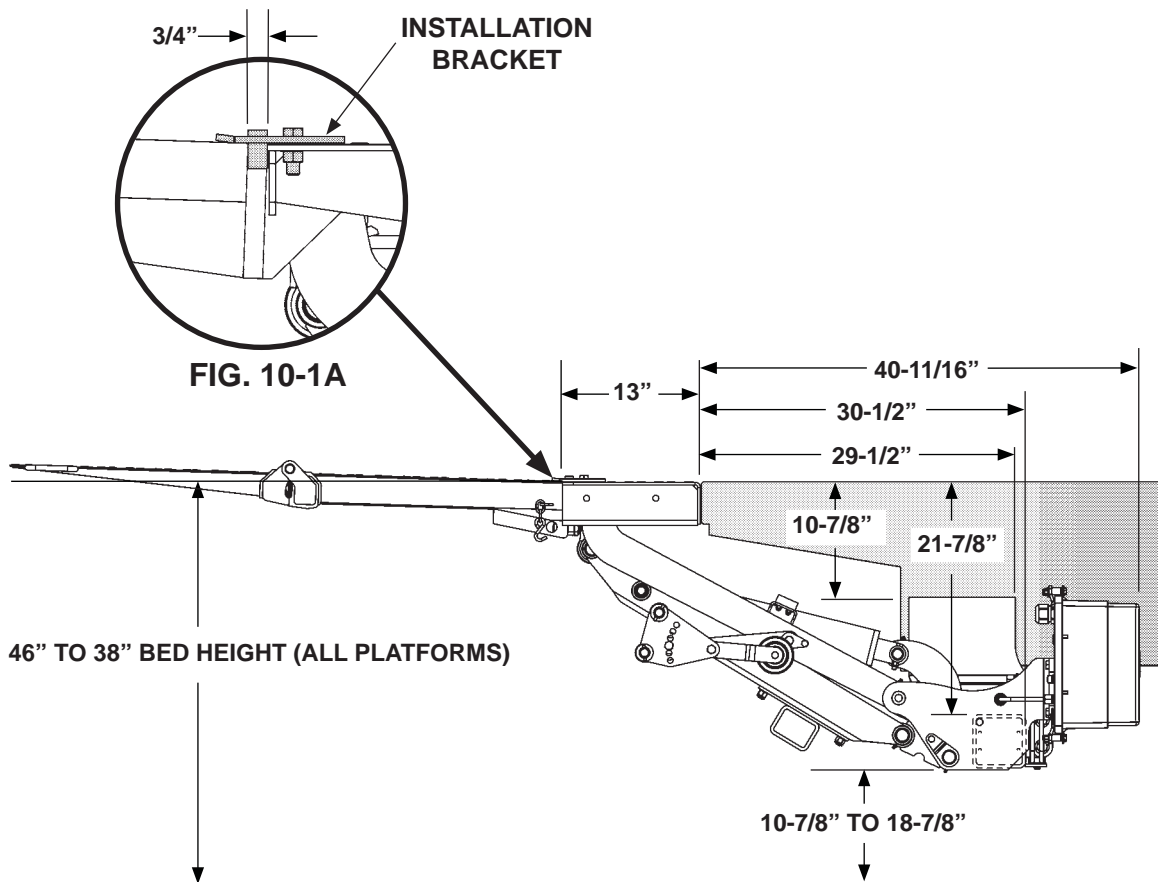

**MXT-25 & MXT-33 LOW BED CLEARANCES
(46" TO 38" BED HEIGHT)**

FIG. 10-1

VEHICLE REQUIREMENTS - Continued

CAUTION

- To prevent platform from being damaged, make sure vehicle frame is cut correctly. If the cutouts are incorrect, platform may hit vehicle frame or underbody when stowing the Liftgate.
- Installer is responsible for ensuring that vehicle body and frame modifications do not adversely affect the integrity of the body and frame.

NOTE: The dimensions, shown in the illustration below, are maximums except as indicated.

NOTE: The platform cutout area shown below applies to trucks. If the rear sill dimension is taller than 5", it may need to be modified. Check with body manufacturer before modifying the rear sill and for best practices to reinforce cutout areas in the rear sill.

2. Fit the Liftgate to vehicle body by cutting vehicle frame as shown in **FIG. 11-1**.

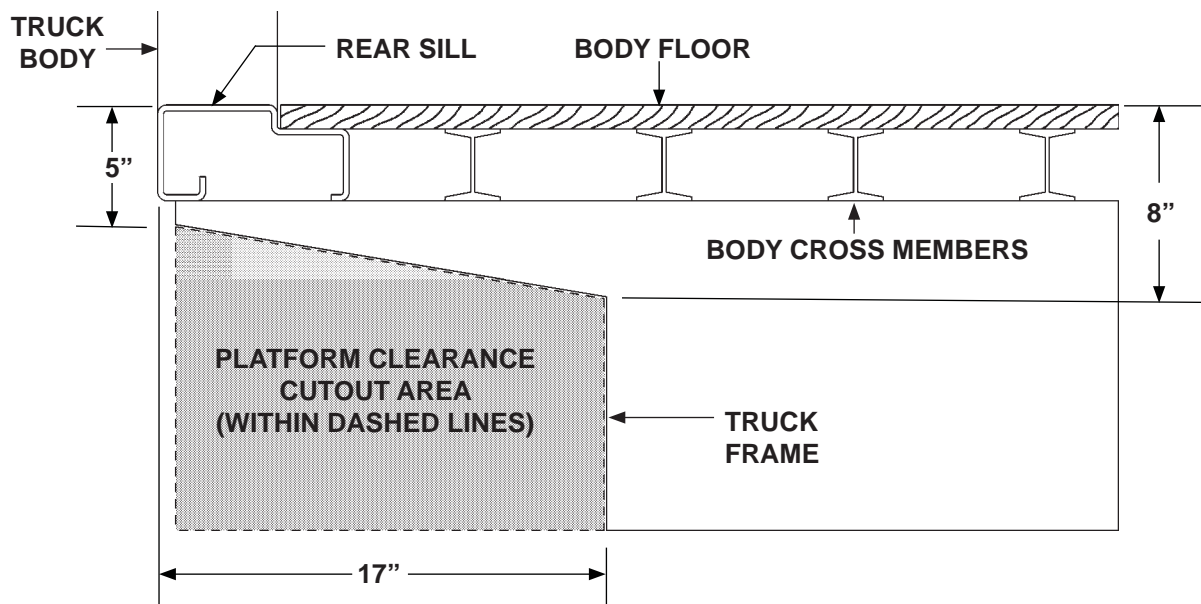

**VEHICLE FRAME CUTOUT FOR PLATFORM CLEARANCE
(46" TO 38" BED HEIGHT)**

FIG. 11-1

CENTER OF MASS

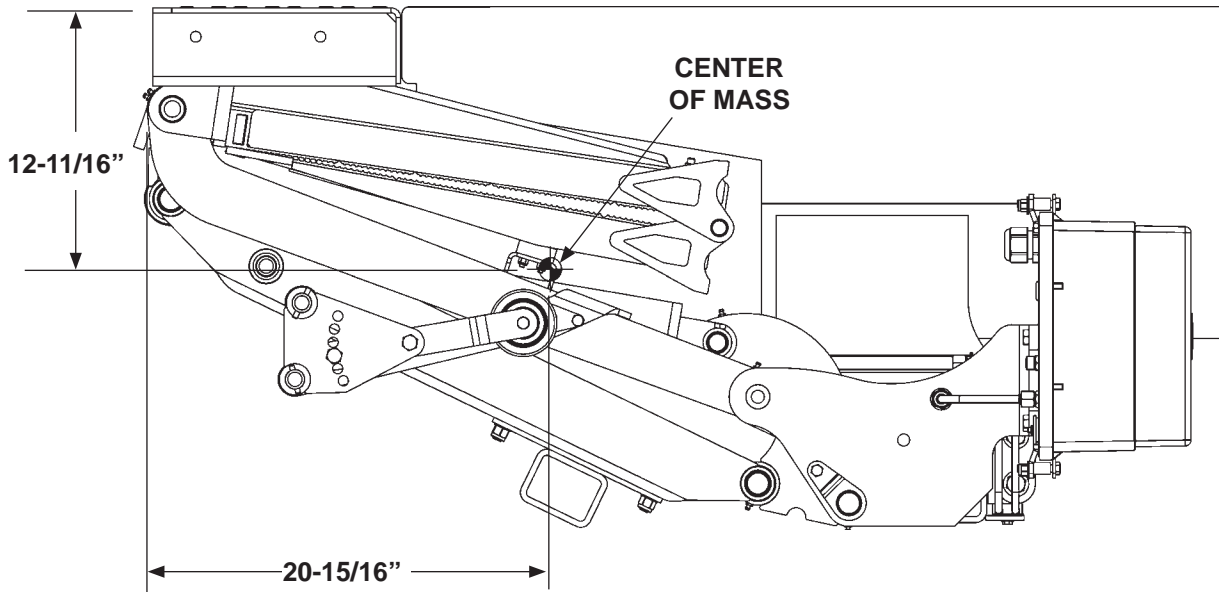

**MXT-25 & MXT-33 CENTER OF MASS
(ALUMINUM PLATFORM, STOWED POSITION)
FIG. 12-1**

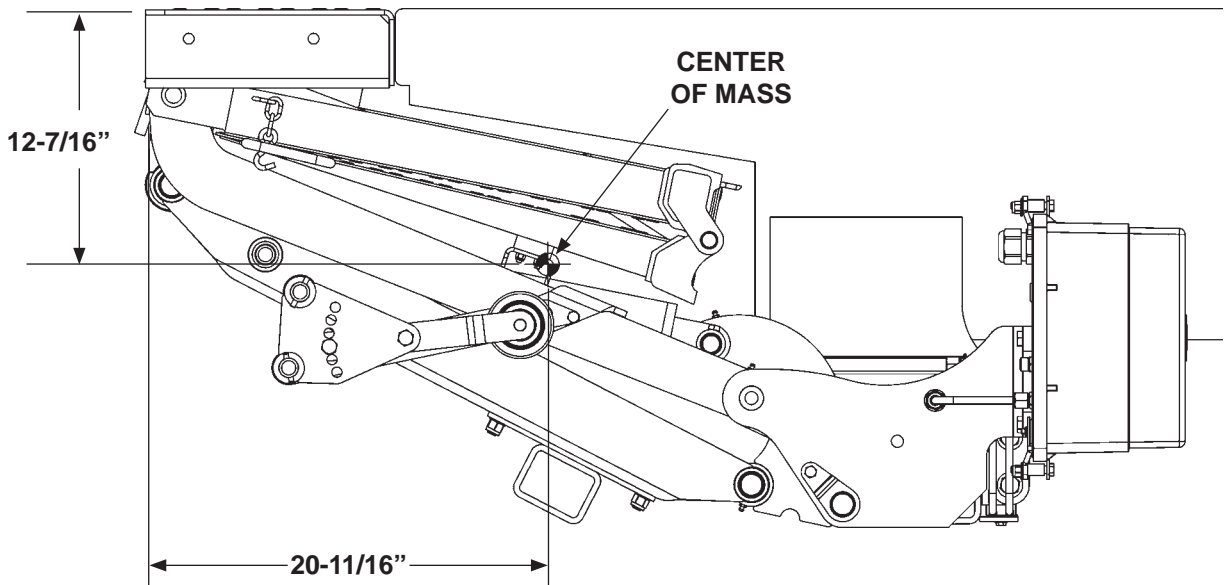

**MXT-25 & MXT-33 CENTER OF MASS
(STEEL PLATFORM, STOWED POSITION)
FIG. 12-2**

STEP 1 - ATTACH EXTENSION PLATE TO VEHICLE

CAUTION

To preserve the corrosion-resistant properties of the galvanized finish, MAXON recommends bolting the galvanized extension plate to vehicle.

NOTE: MXT-25 & MXT-33 Liftgate extension plate comes with bolt holes so it can be bolted to vehicle body with optional bolt kit. **GRADE 8 bolts are required.** MAXON recommends getting the optional extension plate hardware kit listed in **OPTIONS** section. Vehicle body must be drilled according to instructions. Extension plate may also be welded to vehicle body. Do the following bolting or welding instructions for the extension plate.

BOLT EXTENSION PLATE

1. Mark and drill holes into rear sill as shown in **FIGS. 13-1 and 14-1**.

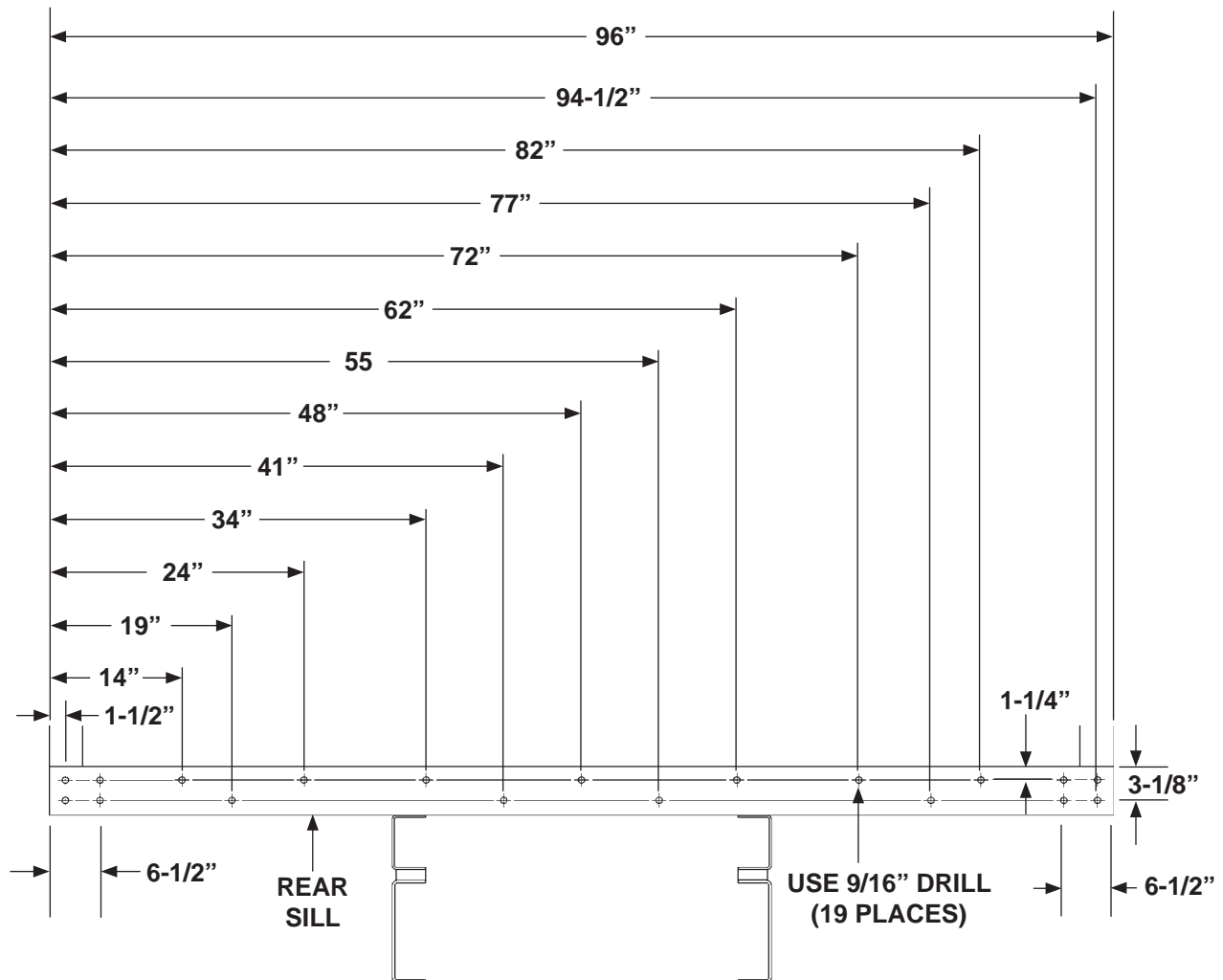

REAR SILL - HOLE LOCATIONS FOR 96" WIDE VEHICLE
FIG. 13-1

STEP 1 - ATTACH EXTENSION PLATE TO VEHICLE - Continued

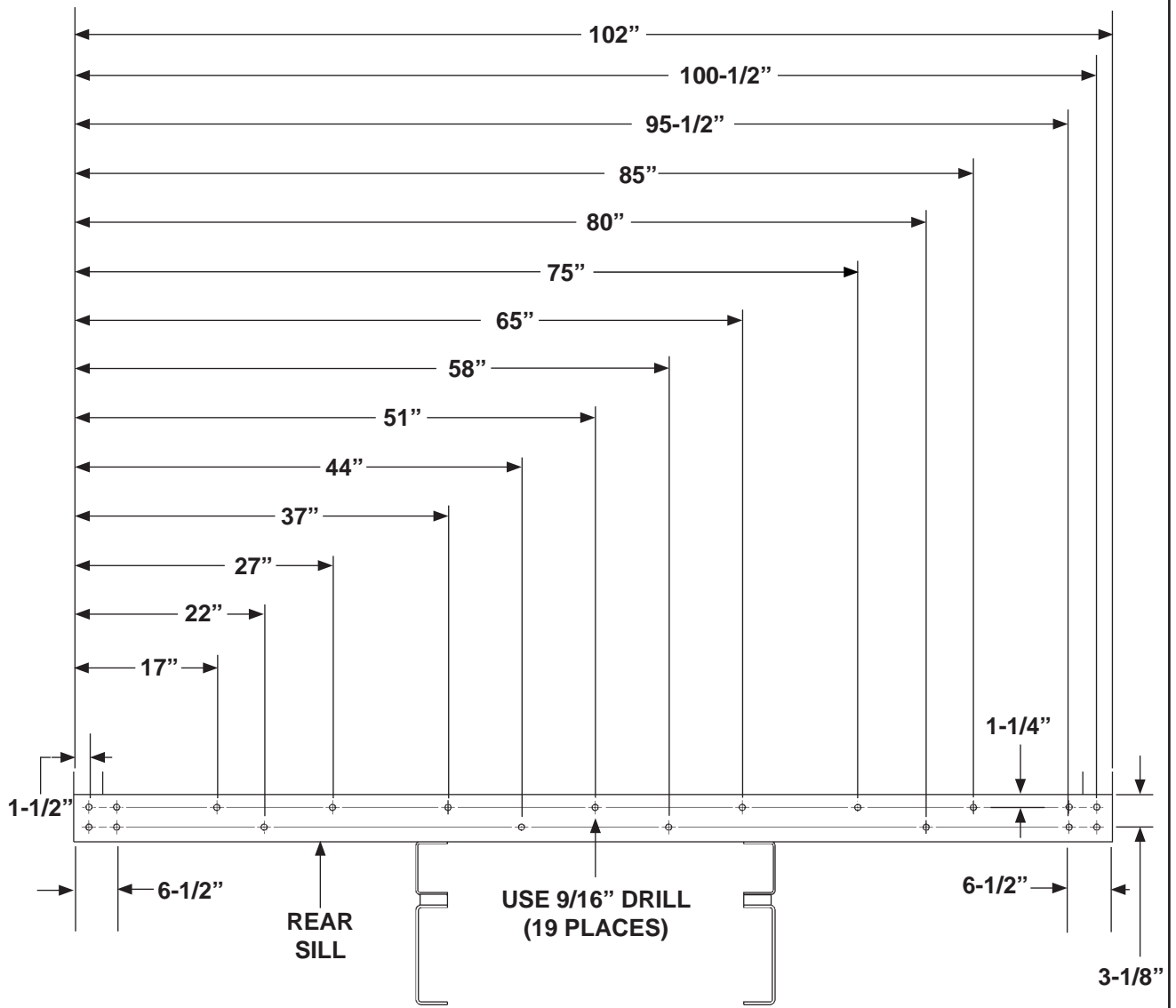

REAR SILL - HOLE LOCATIONS FOR 102" WIDE VEHICLE
FIG. 14-1

MAXON® 11921 Slauson Ave. Santa Fe Springs, CA. 90670 (800) 227-4116 FAX (888) 771-7713

STEP 1 - ATTACH EXTENSION PLATE TO VEHICLE - Continued

CAUTION

The mating surface between the bolt-on extension plate and vehicle rear sill must be as flat as possible. Interference between the mating surfaces could result in a distorted top surface of extension plate when all the bolts are tightened. Distorted extension plate can also make the dual steps difficult to install correctly. Remove interference or shim rear sill to eliminate or reduce the possibility of a distorted extension plate.

NOTE: Do not tighten extension plate bolts and lock nuts until:

- All the bolts and lock nuts are in place.
- Mating surfaces of extension plate and rear sill are made flat as possible.
- Top of extension plate is flush with top of rear sill.

NOTE: Weld the LH and RH ends of the extension plate to vehicle body as shown in **FIG. 15-1** if any of the following conditions apply.

- Bolt holes are not accessible on the corner posts of the vehicle body.
- Liftgate will be used for dock loading applications.
- As required by body/trailer manufacturer

2. Bolt extension plate to vehicle as shown in **FIG. 15-1**. If necessary, reposition extension plate so top surface is flush with top surface of sill. Then, torque bolts and lock nuts to **105 +/-20 lb-ft.**

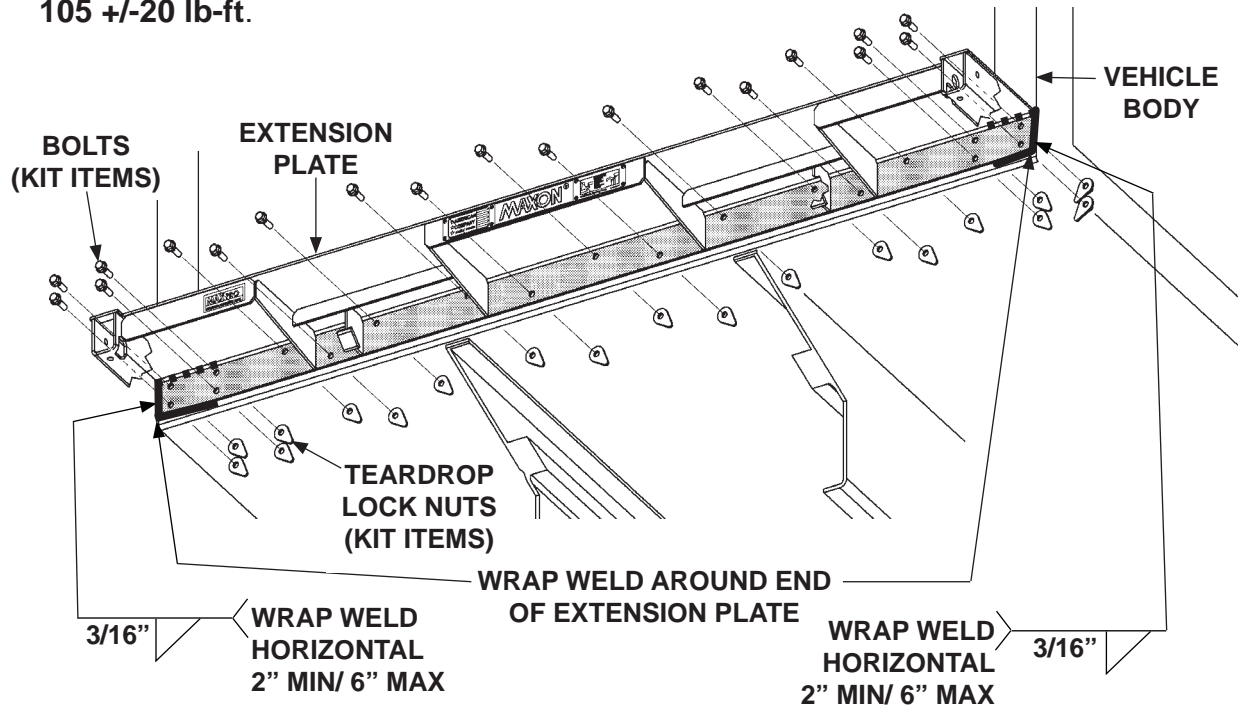

**BOLTING EXTENSION PLATE (96" WIDE EXTENSION PLATE SHOWN)
FIG. 15-1**

NOTE: An optional 102" wide extension kit is available for 102" wide vehicles.

STEP 1 - ATTACH EXTENSION PLATE TO VEHICLE - Continued

WELD EXTENSION PLATE (ALTERNATE METHOD)

CAUTION

To preserve the corrosion-resistant properties of the galvanized finish, MAXON recommends bolting the galvanized extension plate to vehicle.

CAUTION

To protect the original paint system if equipped, a 3" wide area of paint must be removed from all sides of the weld area before welding.

NOTE: Before welding extension plate to vehicle body, make sure:

- Inboard edge of extension plate is flush with the top of sill on vehicle body.
- Top surface of extension plate is level with the ground.

NOTE: For welding galvanized steel, refer to recommended practices as outlined in **AWS (American Welding Society) D19.0 Welding Zinc-Coated Steel.**

1. Center the extension plate on vehicle body. Before welding extension plate to vehicle body, make sure top surface of extension plate is flush with floor of vehicle body. Weld the extension plate to vehicle body sill as shown in **FIGS. 16-1 and 17-1.**

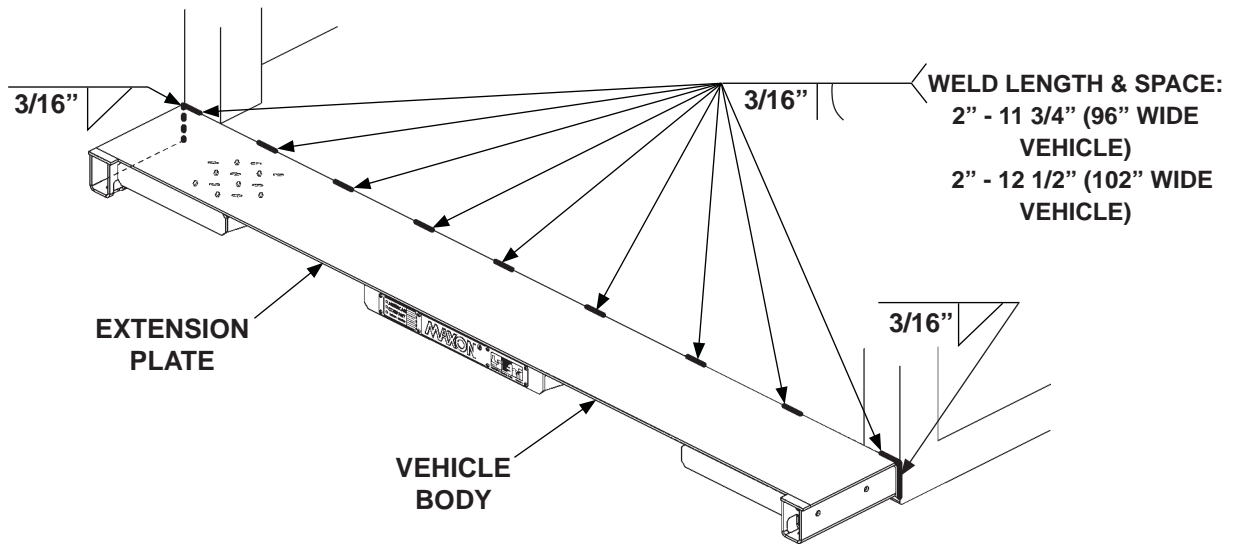

EXTENSION PLATE WELDS - VIEWED FROM ABOVE
FIG. 16-1

STEP 1 - ATTACH EXTENSION PLATE TO VEHICLE - Continued

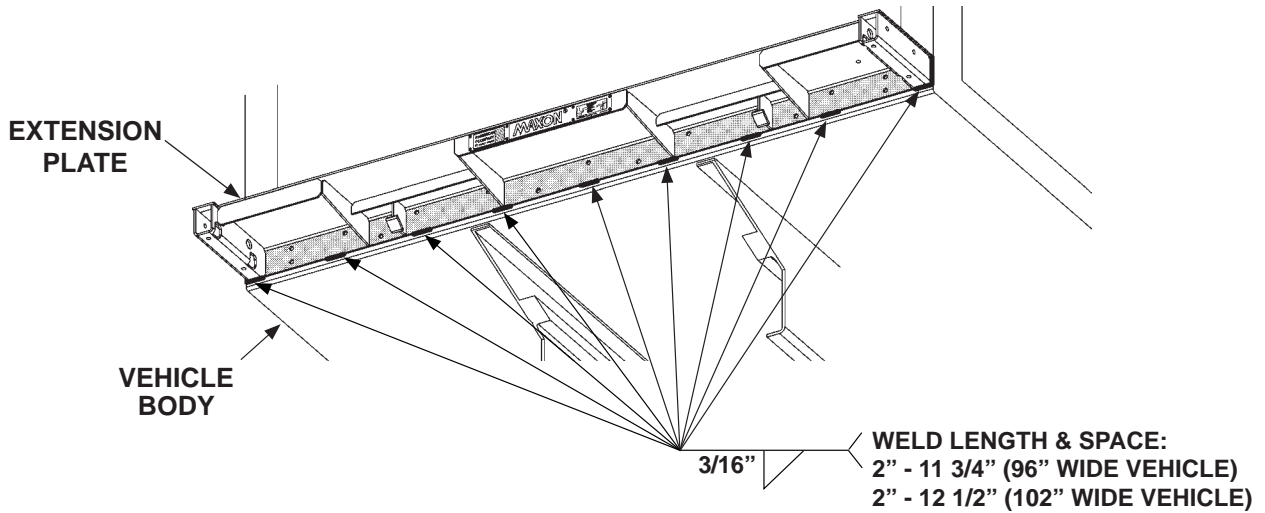

EXTENSION PLATE WELDS - VIEWED FROM UNDERNEATH
FIG. 17-1

NOTE: During installation of Liftgate, installation brackets keep the heel of the platform level with extension plate and maintain a $\frac{3}{4}$ " gap between extension plate and heel of platform. Make sure dowel on installation brackets is pushed snug against extension plate when tightening screws. The extension plate has bolt holes for bolting on the installation brackets provided in parts box.

2. Bolt 2 installation brackets (parts box items) on the extension plate as shown in **FIG. 17-2**. Tighten hex nuts securely.

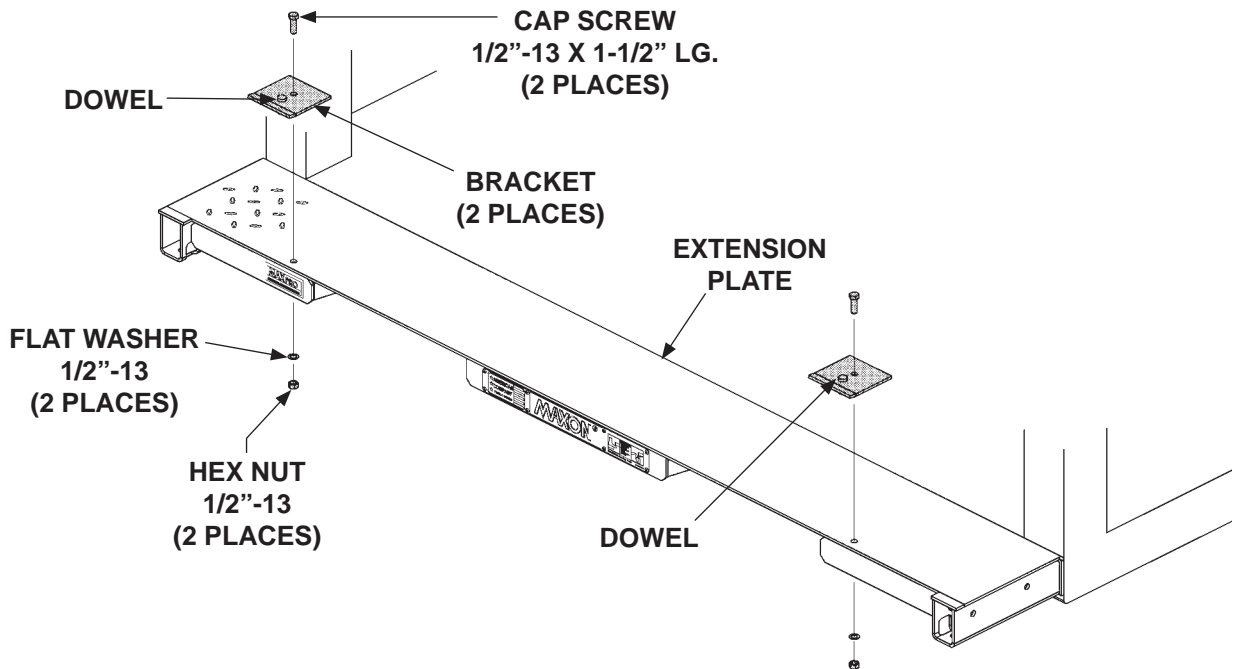

BOLTING ON INSTALLATION BRACKETS
FIG. 17-2

STEP 2 - WELD LIFTGATE TO VEHICLE

NOTE: MXT-25 and MXT-33 Liftgates are equipped with mounting plates installed at the factory. Mounting plate widths are shown based upon truck frame widths. Ensure you have the correct mounting plate kit for your application.

NOTE: If it's necessary to unbolt mounting plates from main frame (**FIG. 18-1** & **FIG. 18-2**), torque mounting plate nuts and bolts **220-240 lb-ft.**

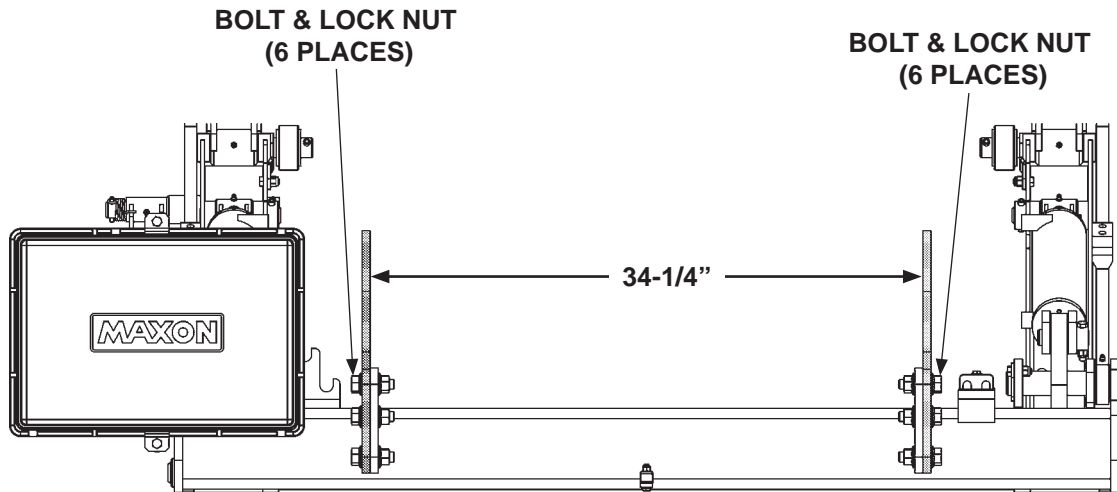

BOLT-ON MOUNTING PLATES 34-1/4"
(34" CHASSIS)
FIG. 18-1

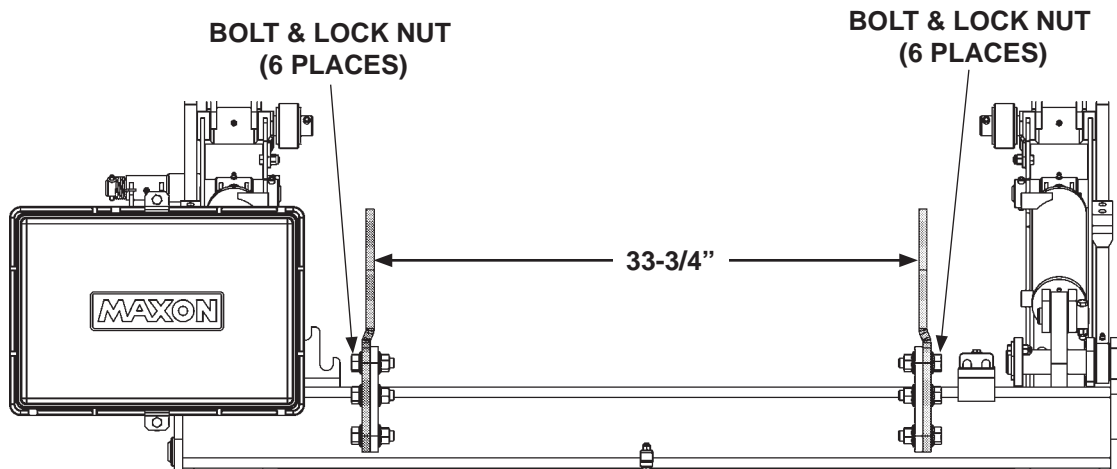

BOLT-ON MOUNTING PLATES 33-3/4"
(33-1/2" CHASSIS)
FIG. 18-2

STEP 2 - WELD LIFTGATE TO VEHICLE - Continued

1. Unfold the platform and flipover (FIG. 19-1).

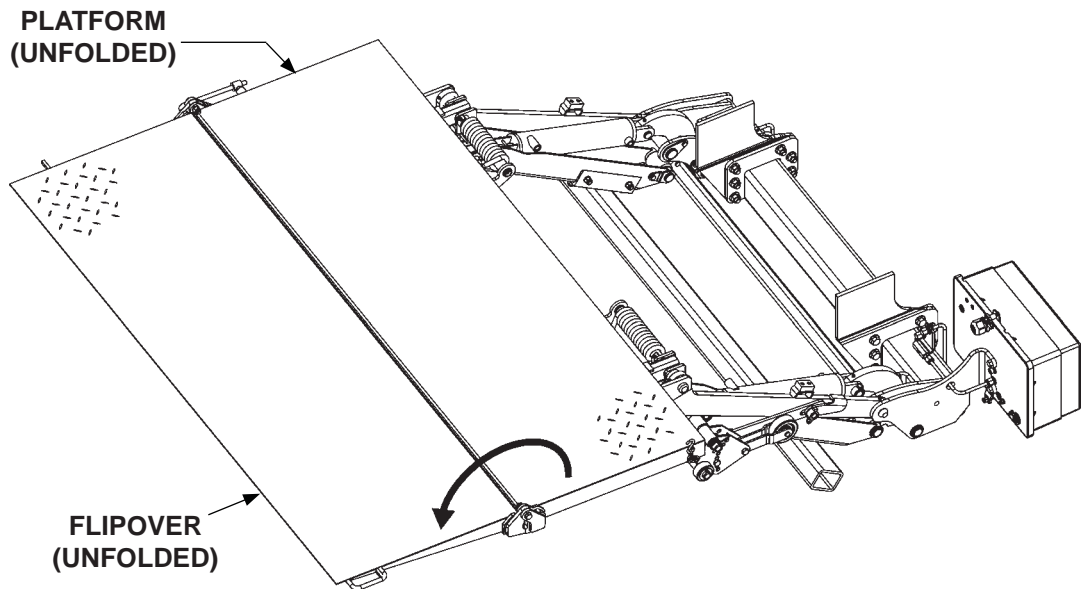

PLATFORM & FLIPOVER UNFOLDED
FIG. 19-1

STEP 2 - WELD LIFTGATE TO VEHICLE - Continued

⚠ CAUTION

To prevent damage to the flipover, NEVER hoist the Liftgate by the flipover as shown in FIG. 20-2. Hoist the Liftgate by the platform only as shown in FIG. 20-1.

2. Make sure hoist is set up the correct way (FIG. 20-1). Place a "C"-clamp on each side of platform as shown in FIG. 20-1. (Clamps prevent hoist chain from slipping off platform.) Place chain all around platform (FIG. 20-1).

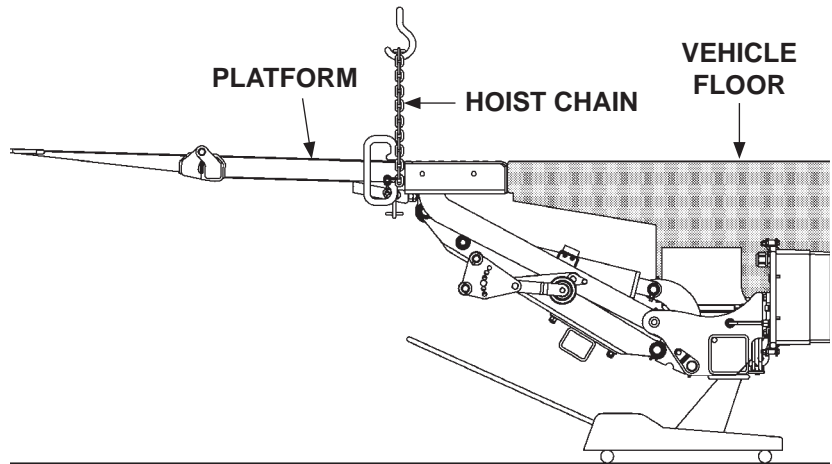

CORRECT WAY TO HOIST LIFTGATE
FIG. 20-1

3. Hoist the Liftgate. Then, place floor jack under main frame (FIG. 20-1). Jack the Liftgate into position. Make sure vehicle floor is horizontal, pins are lined up, and that the platform is pushed tight against dowels of the installation brackets (FIG. 20-1).

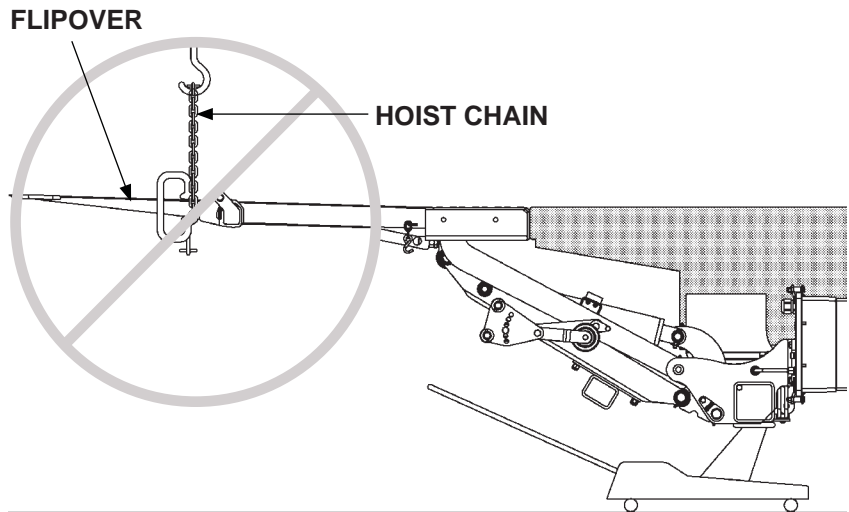

INCORRECT WAY TO HOIST LIFTGATE
FIG. 20-2

STEP 2 - WELD LIFTGATE TO VEHICLE - Continued

CAUTION

Prevent damage to hydraulic hoses. If welding next to hydraulic hoses, use a protective cover such as a welding blanket to cover the hoses.

CAUTION

To protect the original paint system, if equipped, a 3" wide area of paint must be removed from all sides of the weld area before welding.

CAUTION

When using an electric welder, connect the welder ground to one of the parts being welded, as close to the weld as possible. Failure to comply could result in damage to cylinders and electrical parts.

4. Clamp both LH and RH mounting plates to vehicle frame. Weld the mounting plates to vehicle frame as shown in **FIG. 21-1**.

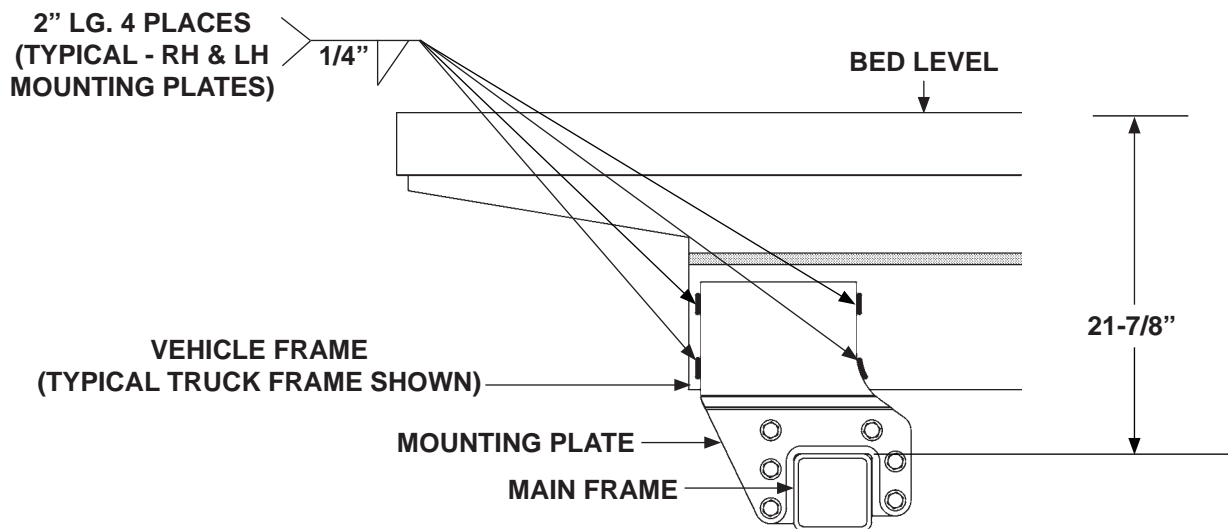

WELD TO VEHICLE FRAME
(RH SIDE SHOWN)

FIG. 21-1

STEP 3 - ATTACH OPTIONAL BATTERY BOX & FRAME TO VEHICLE (IF EQUIPPED)

RECOMMENDED CONFIGURATION

NOTE: Make sure the Liftgate power unit, and all batteries on the vehicle for the power unit, are connected correctly to a common chassis ground.

1. Liftgate and optional battery box are typically installed on trucks as shown in **FIG. 22-1**. See the following page for battery and cable connections.

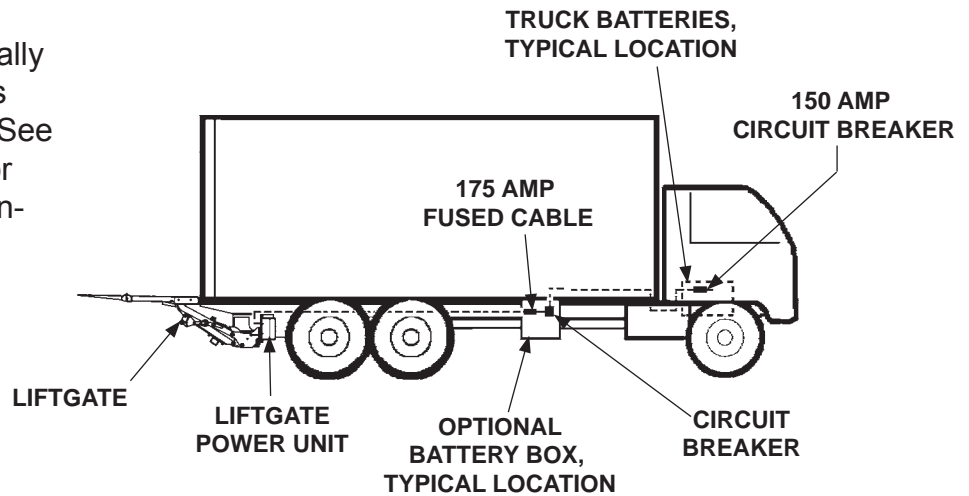

**RECOMMENDED LIFTGATE & BATTERY BOX
INSTALLATION ON TRUCK
FIG. 22-1**

STEP 3 - ATTACH OPTIONAL BATTERY BOX & FRAME TO VEHICLE (IF EQUIPPED) - Continued

2. Select holes on top of battery box frame to align mounting brackets flush to cross members. Refer to **FIGS. 23-1 and 23-1A** for trailers and **FIG. 23-2** for trucks. Bolt mounting brackets to battery box frame as shown in **FIG. 23-1B**. Torque each bolt and lock nut to **85-128 lb-ft.**

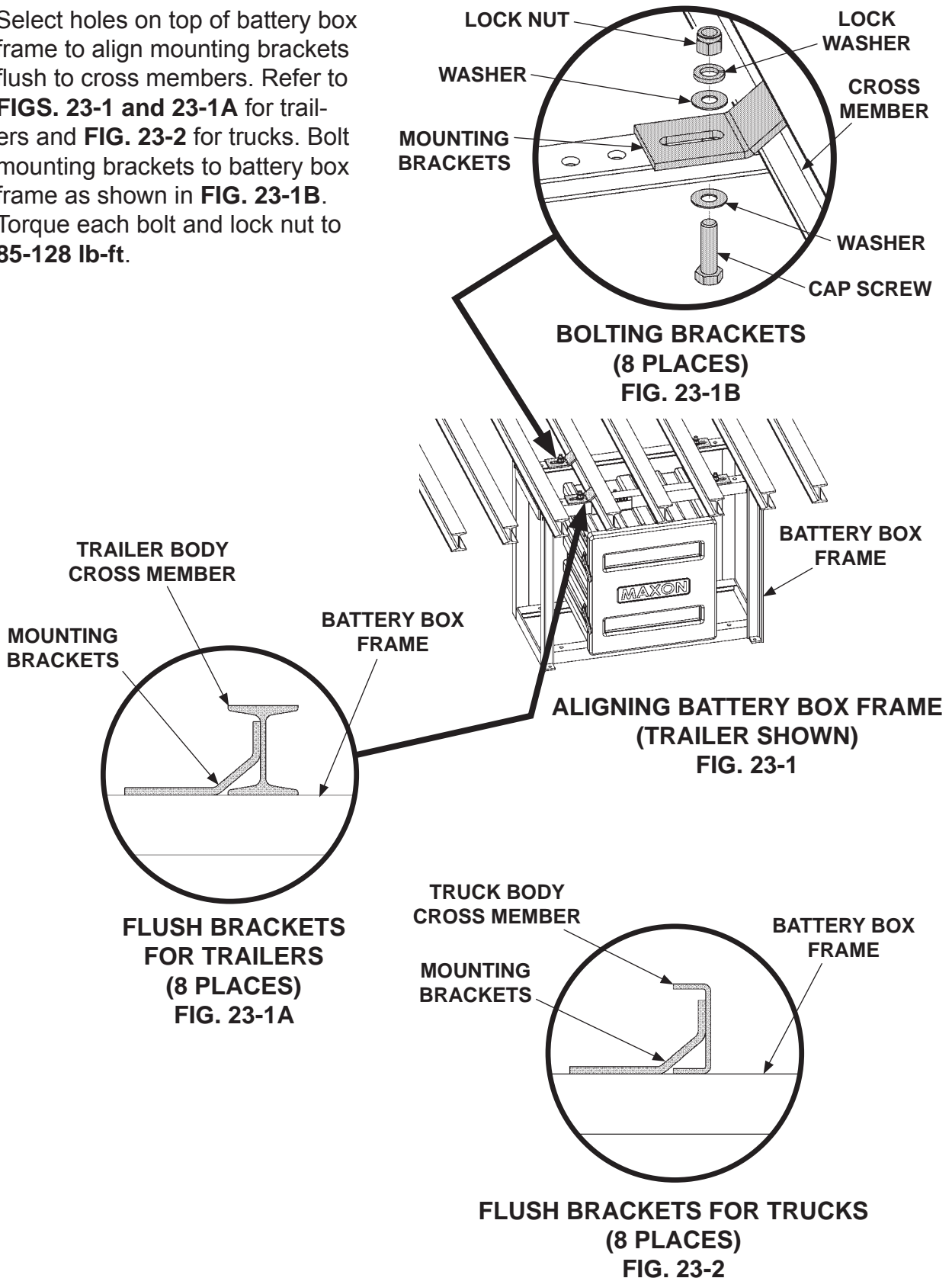

STEP 3 - ATTACH OPTIONAL BATTERY BOX & FRAME TO VEHICLE (IF EQUIPPED) - Continued

NOTE: The hanger brackets for the battery box frame can either be bolted or welded to the cross members of the vehicle body.

- To bolt hanger brackets to cross members, use hanger brackets as a template to mark and drill holes through cross members (FIG. 24-1). Then, bolt hanger brackets to cross members as shown in FIGS. 24-2 and 24-2A. Torque bolts and lock nuts to **85-128 lb-ft**. To weld brackets instead of bolting, weld each hanger bracket to cross member as shown in FIGS. 25-1 and 25-1A. Weld top of bracket if accessible.

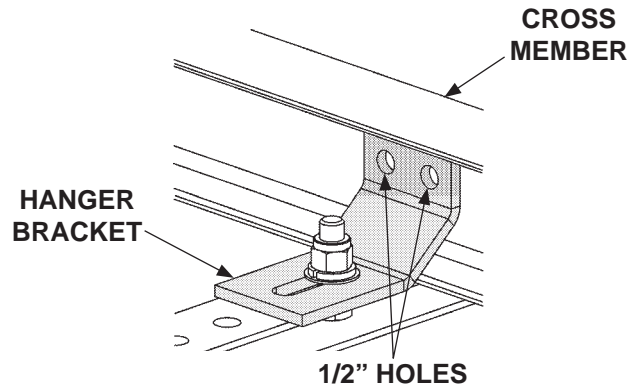

MARK AND DRILL HANGER BRACKET HOLES
FIG. 24-1

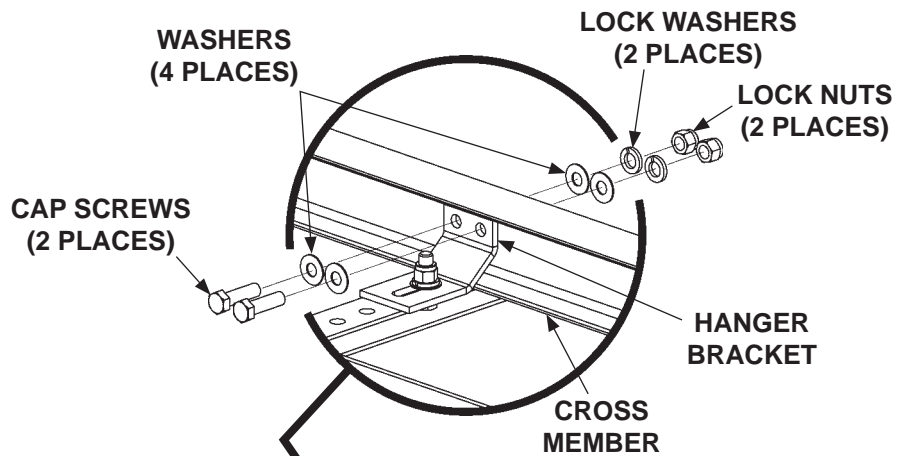

BOLTING HANGER BRACKETS
(8 PLACES)
FIG. 24-2A

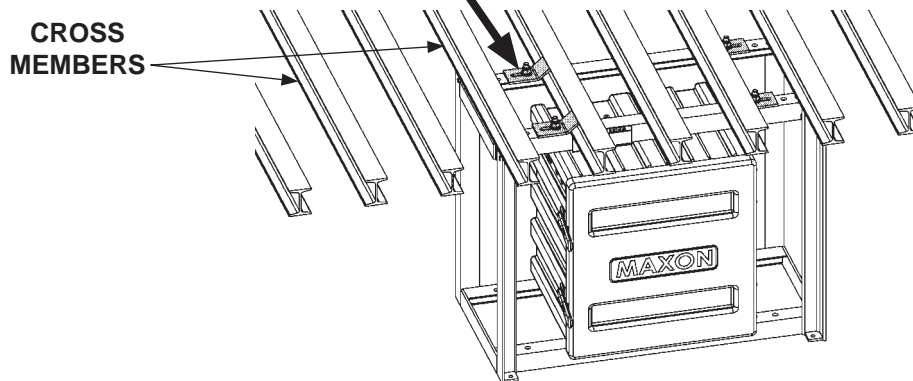

BOLTING FRAME HANGER BRACKETS TO VEHICLE CROSS MEMBERS
FIG. 24-2

STEP 3 - ATTACH OPTIONAL BATTERY BOX & FRAME TO VEHICLE (IF EQUIPPED) - Continued

⚠ WARNING

Recommended practices for welding on steel parts are contained in the current AWS (American Welding Society) D1.1 Structural Welding Code - Steel. Damage to Liftgate and/or vehicle, and personal injury can result from welds that are done incorrectly.

CAUTION

To prevent pump box components from being damaged by electric current from welding, connect welder grounding cable to the part being welded.

CAUTION

Cover pump box and optional battery box with flame-resistant covering before welding pump box frame to vehicle.

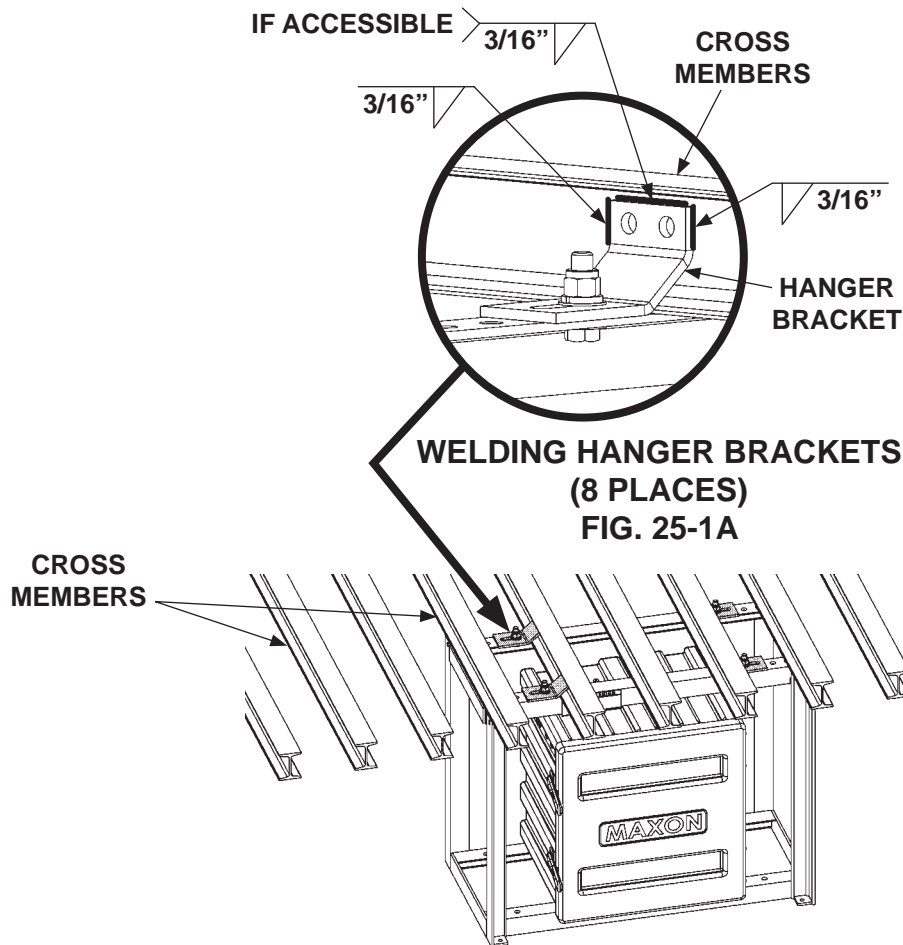

WELDING FRAME HANGER BRACKETS TO VEHICLE CROSS MEMBERS
FIG. 25-1

STEP 3 - ATTACH OPTIONAL BATTERY BOX & FRAME TO VEHICLE (IF EQUIPPED) - Continued

⚠ WARNING

Remove all rings, watches and jewelry before doing any electrical work.

NOTE: Always connect fused end of power cable to battery positive (+) terminal.

NOTE: To connect charge lines, refer to instructions provided with each charge line kit.

4. Connect battery cables, fused cables, and ground cables for 12 volt power as shown in **FIG. 26-1** or 24 volt power as shown in **FIG. 26-1**.

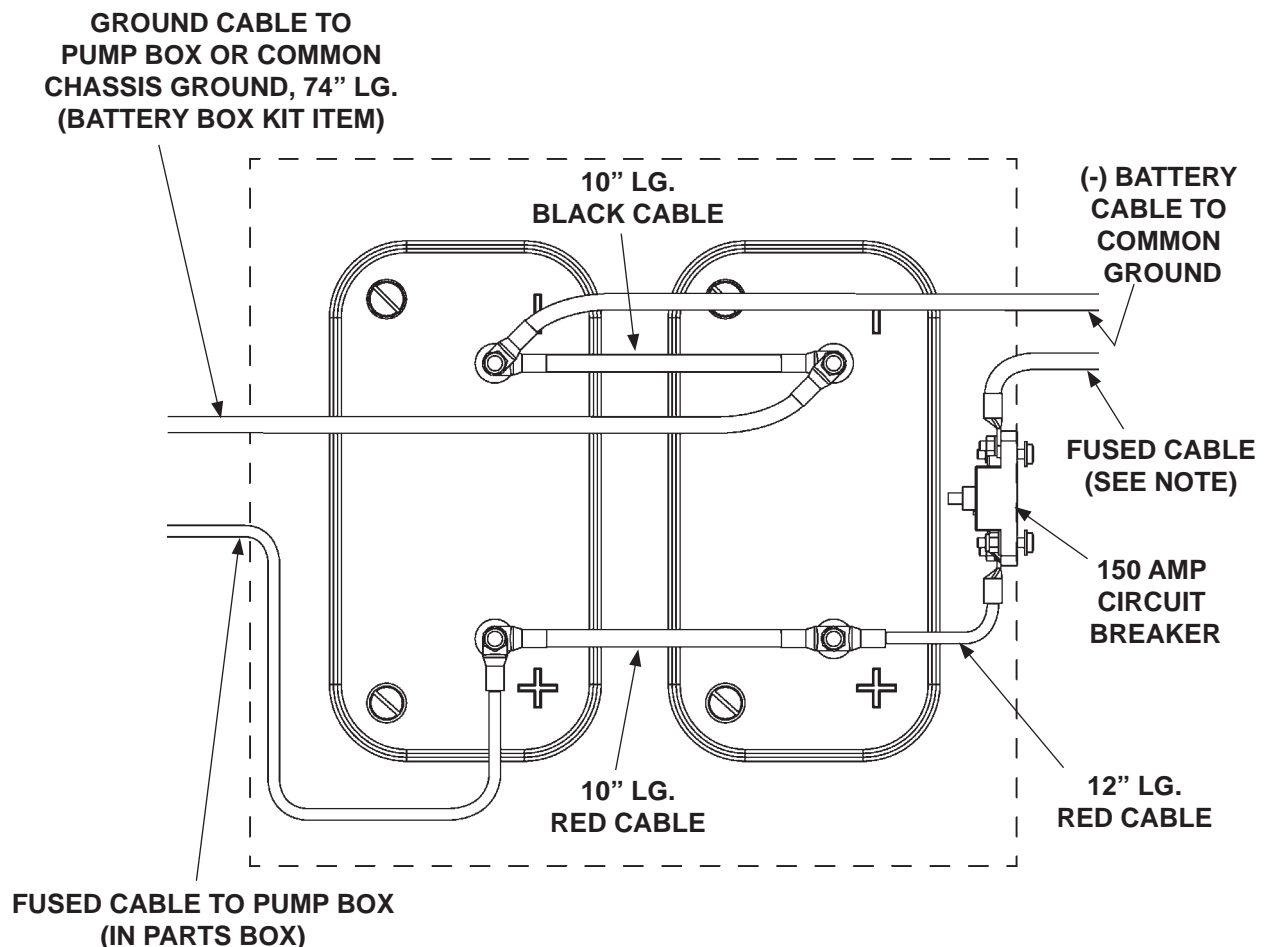

12 VOLT BATTERY CONNECTIONS
FOR 12 VOLT POWER
FIG. 26-1

STEP 3 - ATTACH OPTIONAL BATTERY BOX & FRAME TO VEHICLE (IF EQUIPPED) - Continued

NOTE: Always connect fused end of power cable to battery positive (+) terminal.

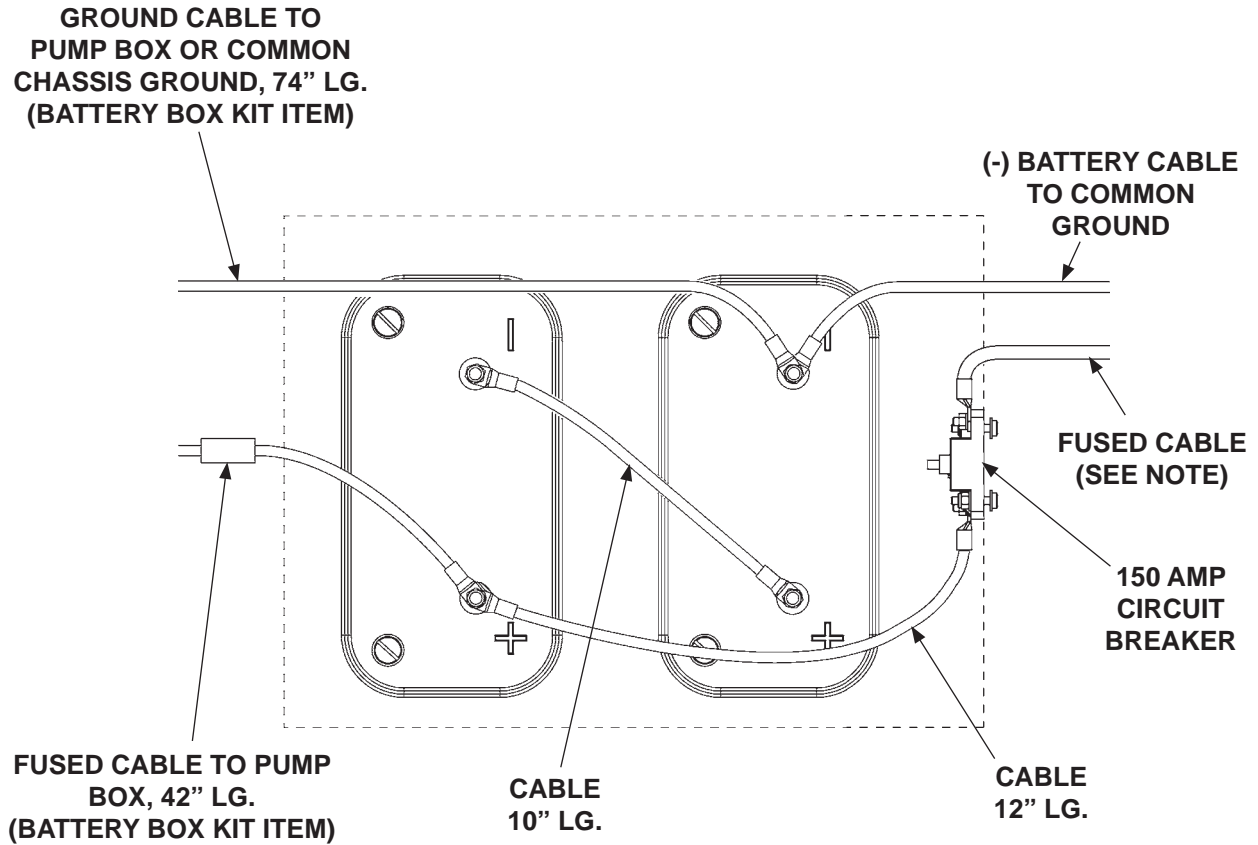

12 VOLT BATTERY CONNECTIONS FOR 24 VOLT POWER
FIG. 27-1

STEP 3 - ATTACH OPTIONAL BATTERY BOX & FRAME TO VEHICLE (IF EQUIPPED) - Continued

⚠ WARNING

Explosive hydrogen gas from charging batteries can accumulate in battery box if not vented from the box. To prevent hydrogen gas from accumulating, ensure the 3 ventilation holes in battery box are not plugged or covered.

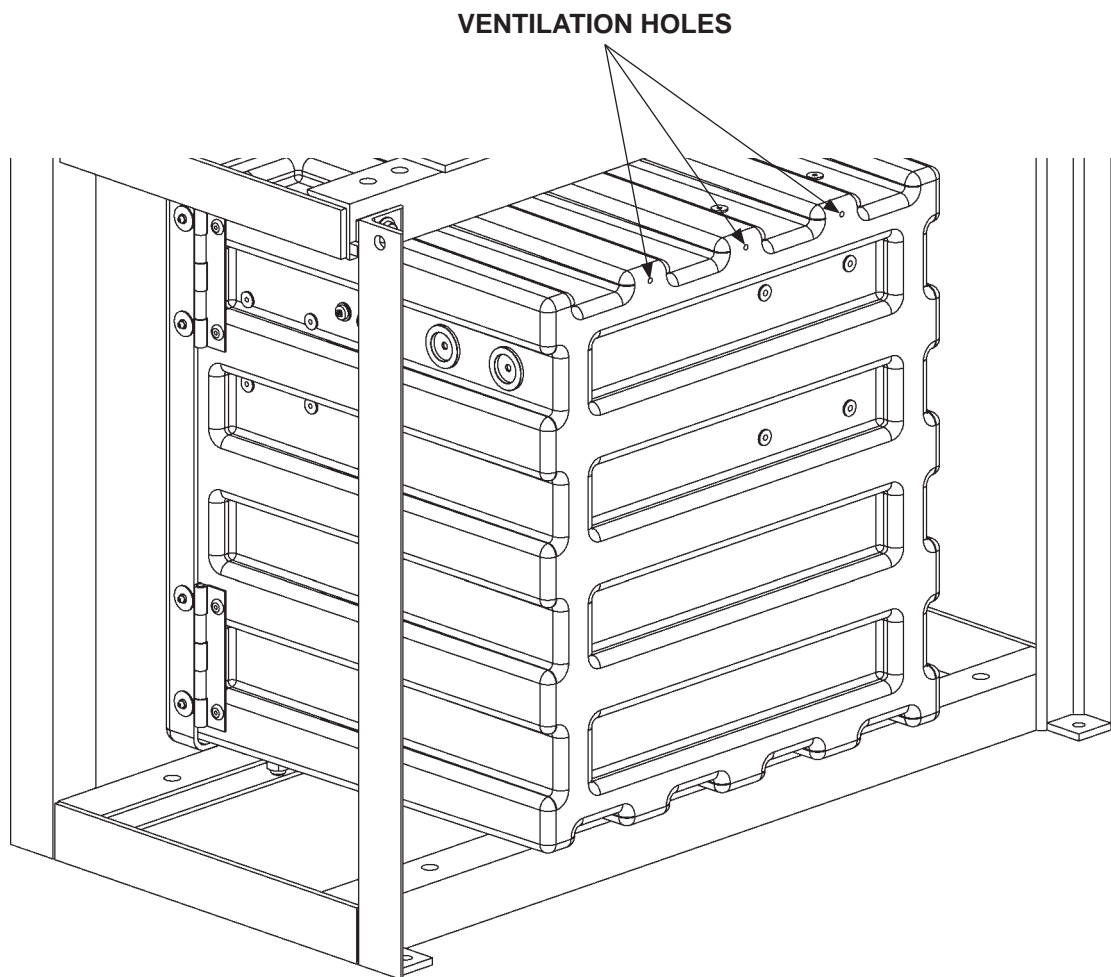

**BATTERY BOX ASSEMBLY (REAR VIEW SHOWN)
FIG. 28-1**

STEP 3 - ATTACH OPTIONAL BATTERY BOX & FRAME TO VEHICLE (IF EQUIPPED) - Continued

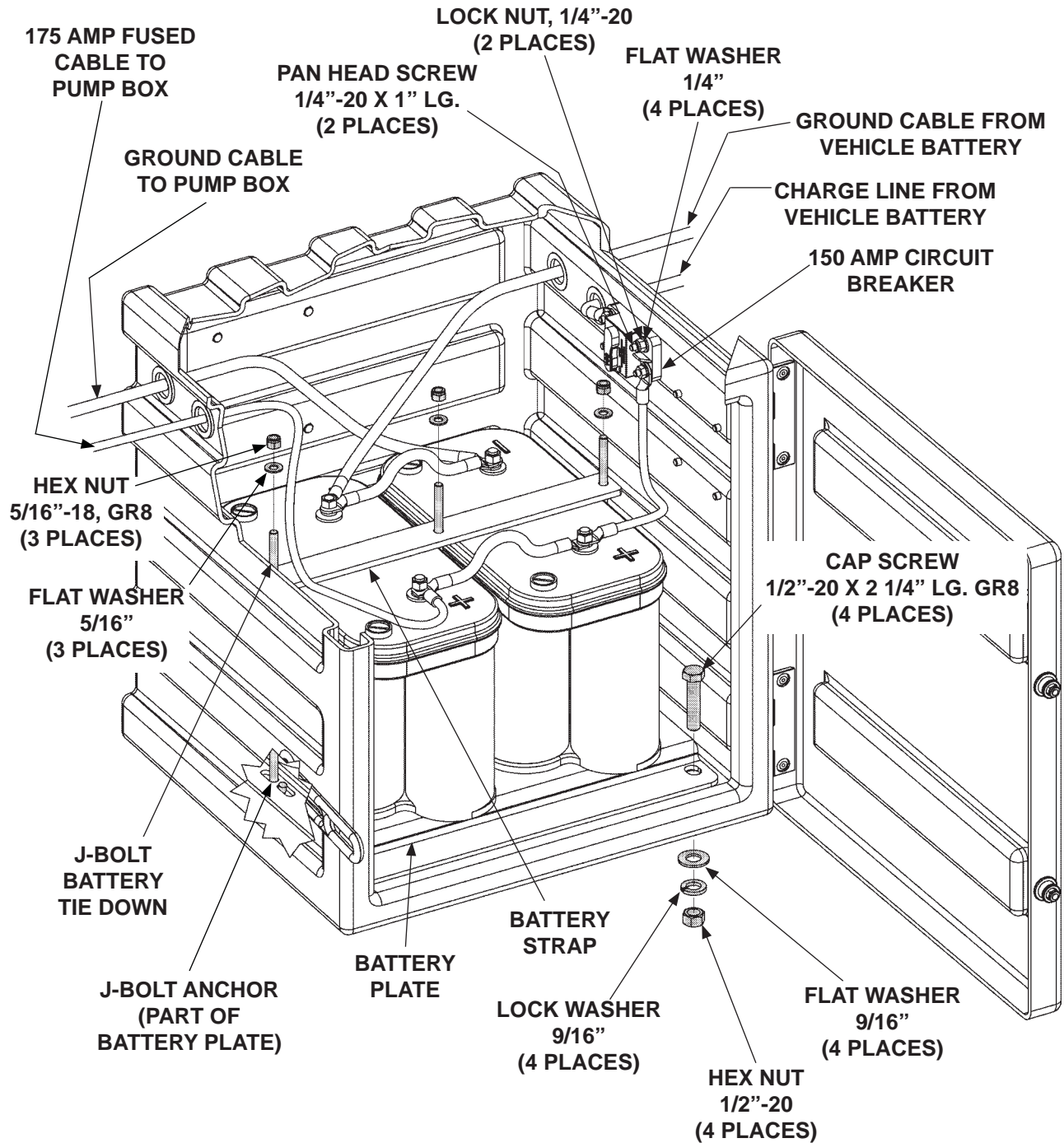

FIG. 29-1

STEP 4 - RUN POWER CABLE

NOTE: Make sure the Liftgate power unit, and all batteries on the vehicle for the power unit, are connected correctly to a common chassis ground.

RECOMMENDED CONFIGURATION

1. Liftgate powered from truck batteries is typically installed on trucks as shown in **FIG. 30-1**. See the following page for running the battery cable.

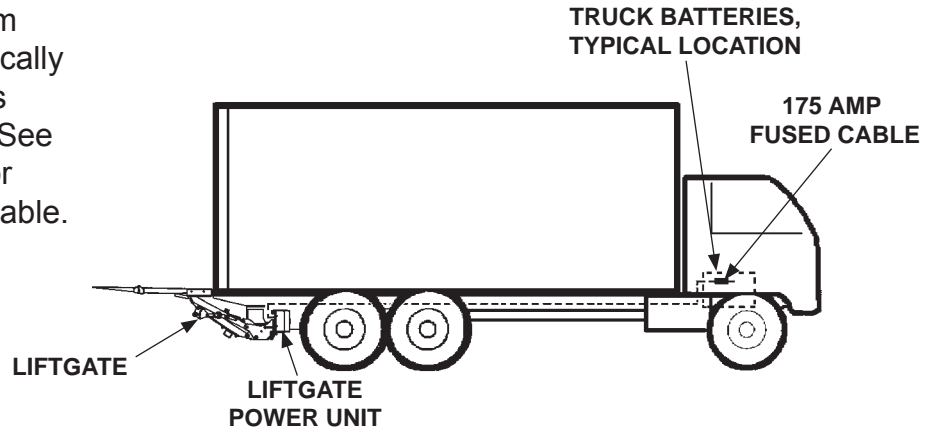

**RECOMMENDED LIFTGATE & BATTERY BOX
INSTALLATION ON TRUCK
FIG. 30-1**

STEP 4 - RUN POWER CABLE - Continued

⚠ CAUTION

Never route an energized wire. Make sure the vehicle battery is disconnected. Always route electrical wires clear of moving parts, brake lines, sharp edges and exhaust systems. Avoid making sharp bends in wiring. Attach securely. If drilling is necessary, first check behind the drilling surface so you do not damage any fuel lines, vent lines, brake lines or wires.

2. Clip fused power cable to vehicle chassis with fuse nearest the vehicle battery, as shown in **FIG. 31-1**. Keep enough cable near the battery to reach the positive terminal without straining cable (after connection). Run cable to pump box on Liftgate.

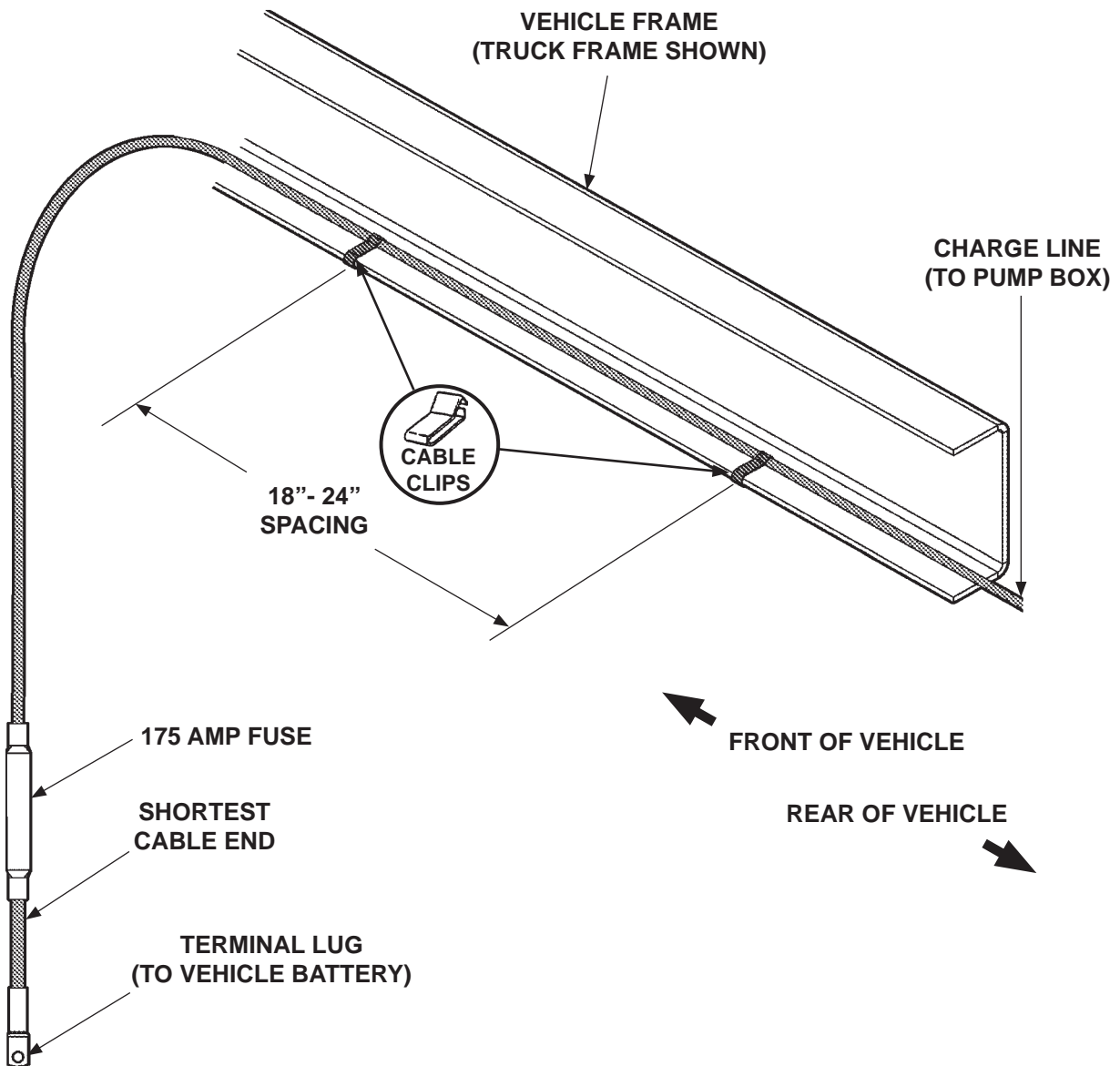
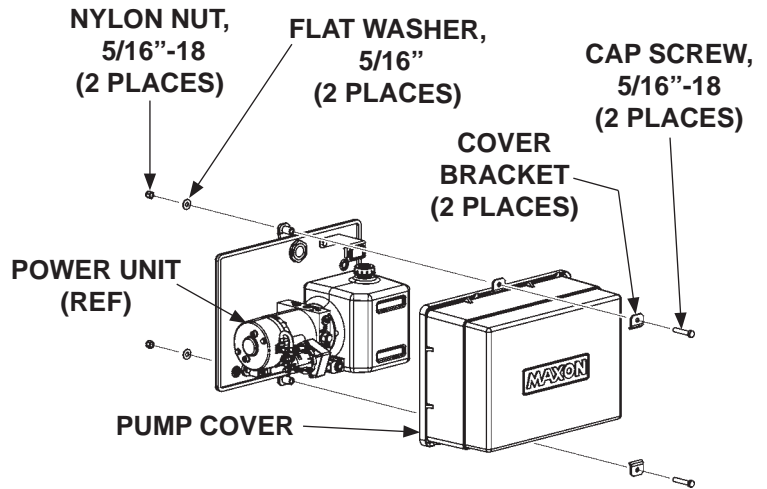

FIG. 31-1

STEP 5 - CONNECT POWER CABLE

1. Unbolt and remove pump cover (FIG. 32-1).



UNBOLTING PUMP COVER
FIG. 32-1

STEP 5 - CONNECT POWER CABLE - Continued

NOTE: Electrical lines must be run into pump box through sealing grommets (**FIG. 33-3**). To ensure a good seal on hydraulic and electrical lines, never cut the sealing grommets.

- Run fused power cable through bottom grommet on pump mounting plate (**FIG. 33-3**).
- On the bare wire end of fused power cable, keep enough length to attach copper terminal lug and reach starter solenoid without putting tension on cable (after connection) (**FIG. 33-1**). Measure (if needed) and then cut excess cable from bare wire end of cable. Put heat shrink tubing (parts box) (**FIG. 33-1**) on the end of the cable (leave room for terminal lug). Crimp copper terminal lug (from parts box) on the fused power cable and shrink the heat shrink tubing (**FIG. 33-2**).
- Form a drip loop on the fused power cable where it enters the grommet from outside the pump mounting plate (**FIGS. 33-3**).

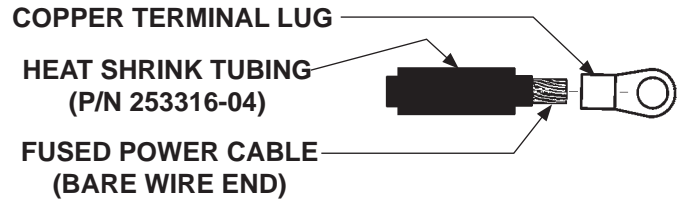

PLACING TERMINAL LUG & HEAT SHRINK TUBING ON FUSED POWER CABLE
FIG. 33-1



TYPICAL FUSED POWER CABLE WITH TERMINAL LUG INSTALLED
FIG. 33-2

CAUTION
Do not over-tighten the terminal nuts on starter solenoid. For the load terminals, torque nuts to 35 lb-in max. Torque the nuts on #10-32 control terminals 10-15 lb-in.

- Remove hex nut and lock washer from battery terminal post on the starter solenoid. Connect the fused power cable to the starter solenoid as shown in **FIG. 33-3**. Reinstall and tighten lock washer and hex nut. Torque hex nut to 30-35 lb-in maximum.

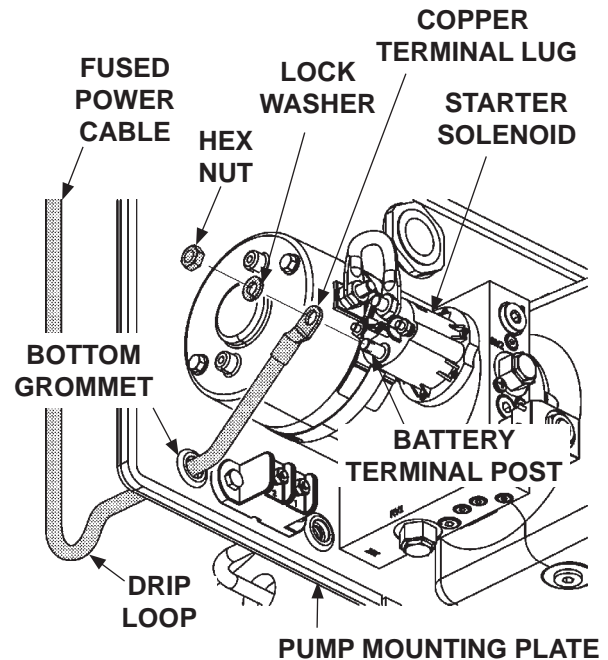

TYPICAL FUSED POWER CABLE CONNECTION (GRAVITY DOWN PUMP SHOWN)
FIG. 33-3

STEP 6 - CONNECT GROUND CABLE

NOTE: Electrical lines must be run into pump box through sealing grommets (FIG. 34-1A). To ensure a good seal on the electrical lines, never cut the sealing grommets.

NOTE: To ensure power unit is correctly grounded, connect 2 gauge ground cable to grounding connection on pump.

1. Insert external ground cable (parts box) through grommet on pump mounting plate (FIGS. 34-1 and 34-1A).
2. Form a drip loop on the ground cable where it enters the grommet from outside the pump mounting plate (FIG. 34-1B).
3. Bolt ground cable to ground connection on pump using existing bolt (FIGS. 34-1 and 34-1B).

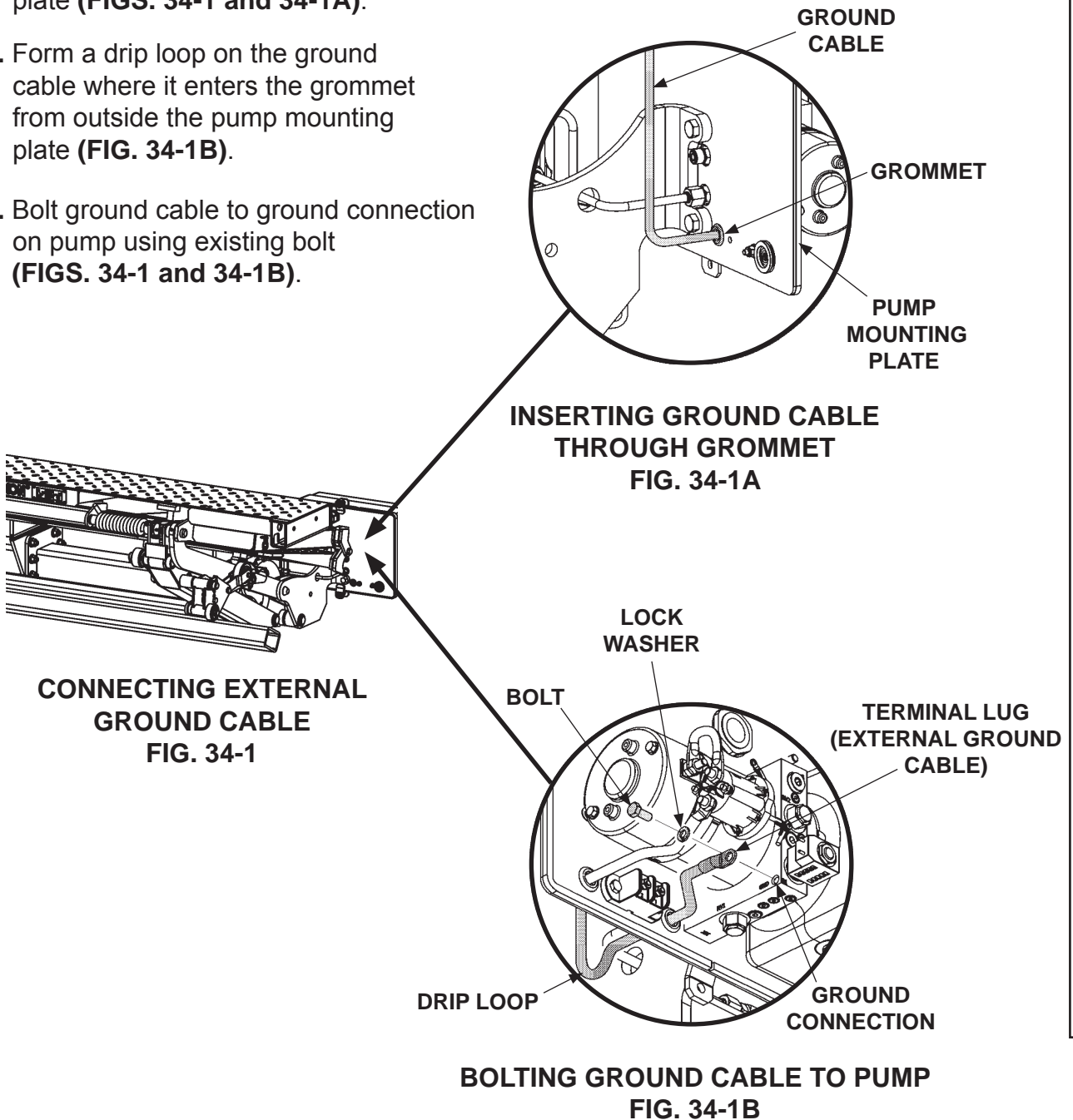

STEP 6 - CONNECT GROUND CABLE - Continued

NOTE: If there is a grounding point on the frame, use it to connect ground cable. Then, skip the step for drilling a hole.

NOTE: Clean the ground cable connection point on the frame down to bare metal.

4. Extend the ground cable to reach vehicle frame (**FIG. 35-1**) without putting tension on cable (after connection). Connect to an existing grounding point if available.
5. If necessary, drill a $11/32$ " (0.343") hole in vehicle frame for bolting the ground cable terminal lug (**FIG. 35-1**).
6. Bolt the ground cable terminal lug to vehicle frame as shown in **FIG. 35-1**.
7. To prevent corrosion, paint or use galvanized spray on bare metal area (**FIG. 35-1**).

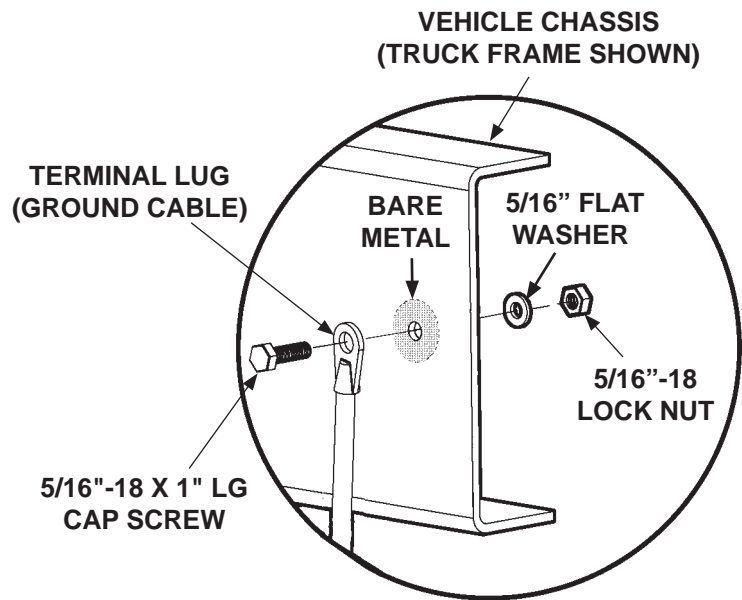
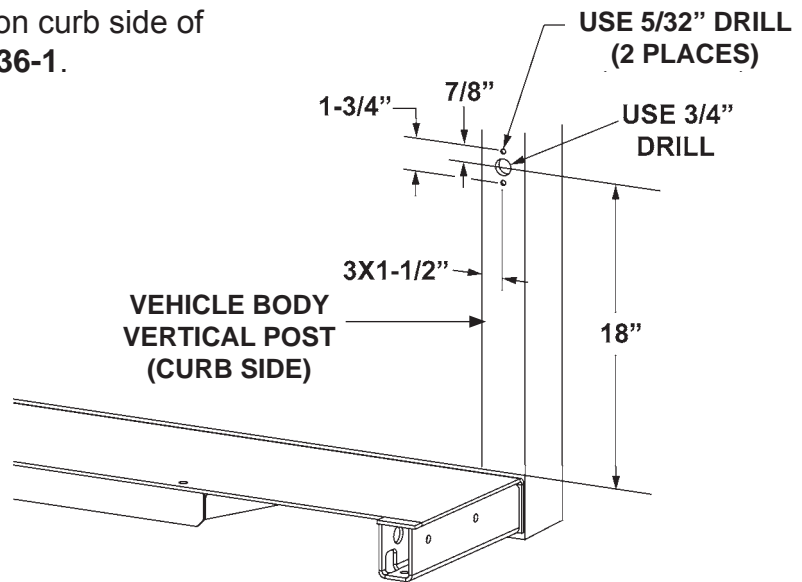

FIG. 35-1

STEP 7 - INSTALL CONTROL SWITCH

1. Measure, mark and drill one 3/4" hole and two 5/32" holes in the vertical post on curb side of vehicle body as shown in **FIG. 36-1**.



DRILLING MOUNTING HOLES
FIG. 36-1

2. Insert control switch wiring harness (parts box) into 3/4" hole on corner post and down the vertical post and under the vehicle body to the pump assembly. (See dashed line - **FIG. 36-2**.)

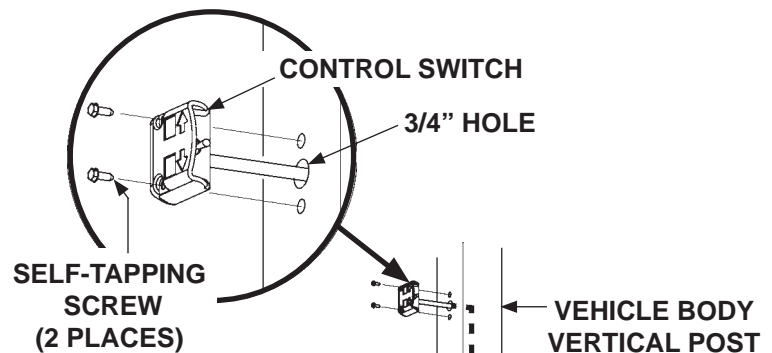

3. Push control switch and cable back into the 3/4" hole in the vertical post until control switch touches the post (**FIG. 36-2**). Attach control switch to vertical post with 2 self-tapping screws (parts box) (**FIG. 36-2**).

4. If necessary, use clamps and self-tapping screws (parts box) to secure switch cable to vehicle under-body and frame (**FIG. 36-2**).

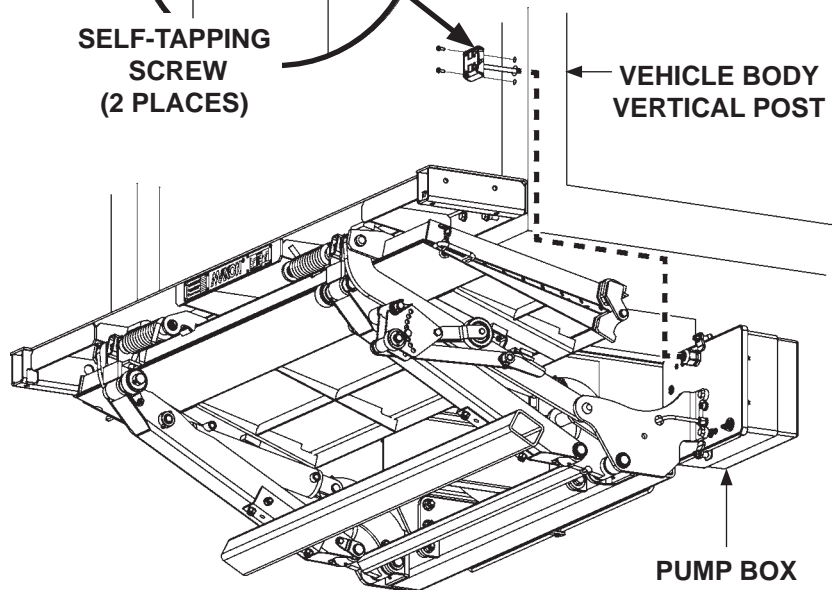

ROUTING CONTROL SWITCH WIRING
FIG. 36-2

STEP 7 - INSTALL CONTROL SWITCH - Continued

NOTE: Electrical lines must be run into pump box through sealing grommets (FIGS. 37-1, 37-2, 38-1 and 38-2). To ensure a good seal on the electrical lines, never cut the sealing grommets.

5. Form a drip loop on the control switch wiring harness where it enters the grommet from outside the pump mounting plate (FIGS. 37-1, 37-2, 38-1 and 38-2).

6. Insert switch wiring through grommet on pump mounting plate (FIGS. 37-1 and 37-2). Connect the switch wiring to the pump assembly as shown in (FIGS. 37-1, 37-2, 38-1, 38-2 and 38-2A).

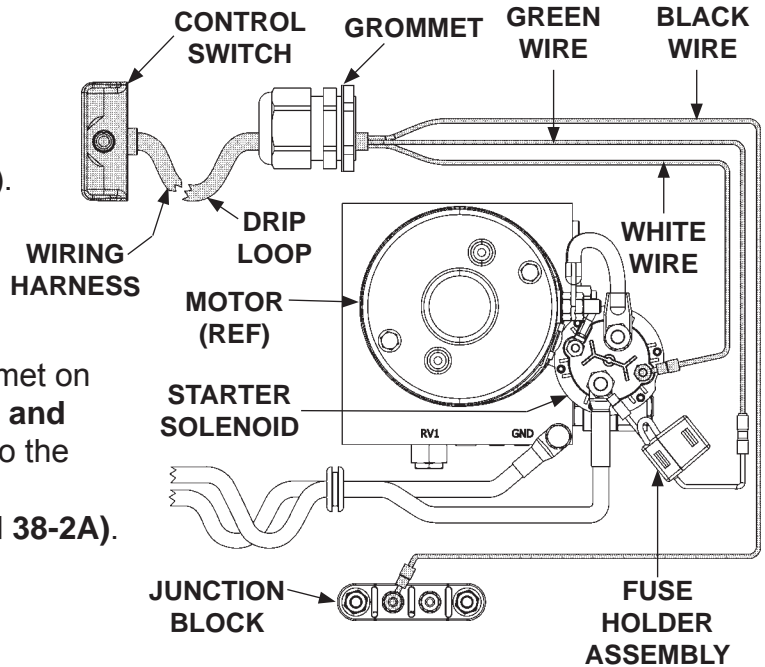

**CONTROL SWITCH WIRING CONNECTIONS
(GRAVITY DOWN)
FIG. 37-1**

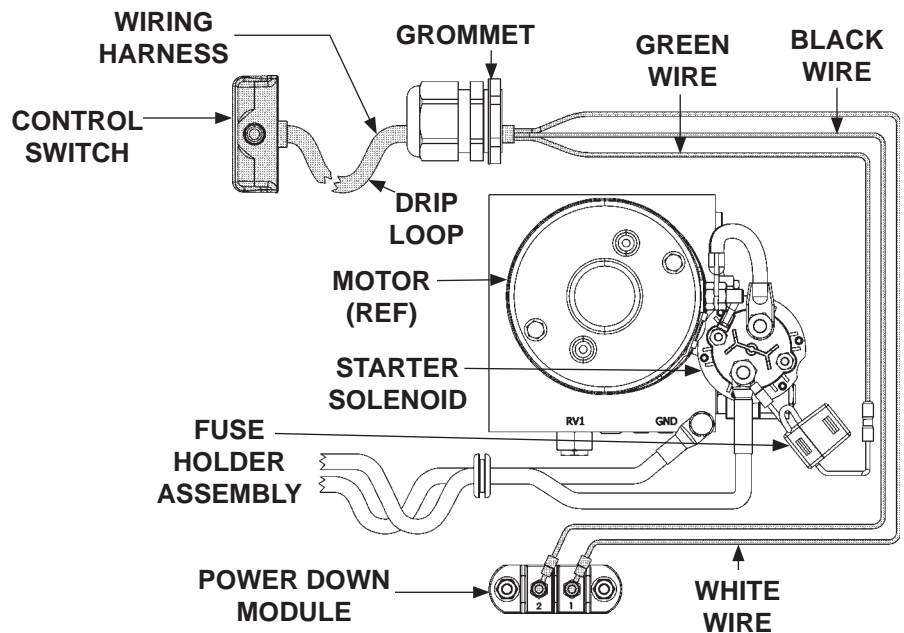

**CONTROL SWITCH WIRING CONNECTIONS
(POWER DOWN)
FIG. 37-2**

STEP 7 - INSTALL CONTROL SWITCH - Continued

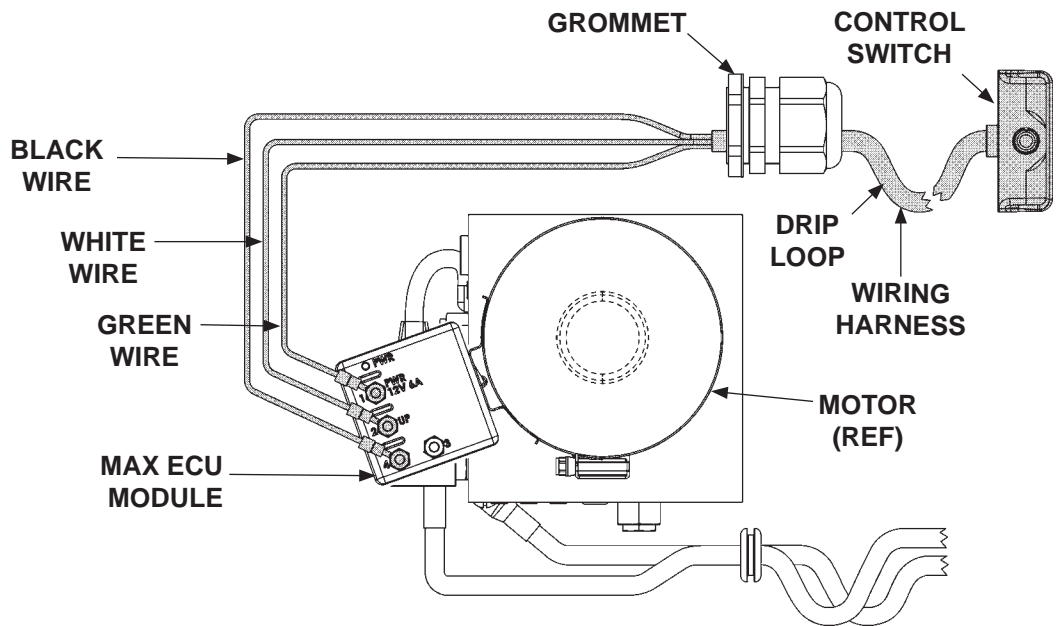

**CONTROL SWITCH WIRING CONNECTIONS
(MAX ECU, GRAVITY DOWN)**

FIG. 38-1

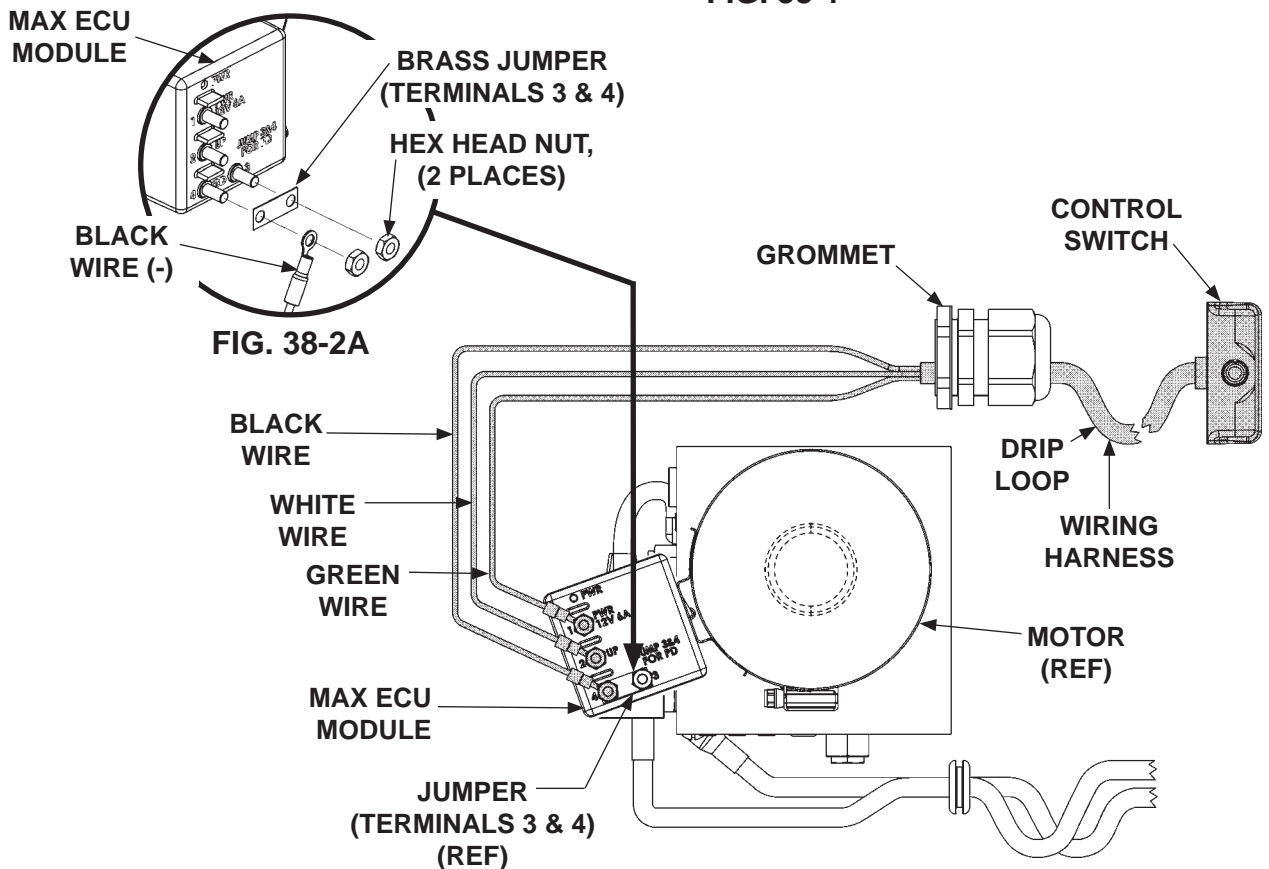

**CONTROL SWITCH WIRING CONNECTIONS
(MAX ECU, POWER DOWN)**

FIG. 38-2

STEP 8 - CHECKING HYDRAULIC FLUID

CAUTION

Keep dirt, water and other contaminants from entering the hydraulic system. Before opening the hydraulic fluid reservoir filler cap, drain plug and hydraulic lines, clean up contaminants that can get in the openings. Also, protect the openings from accidental contamination.

NOTE: Liftgate is shipped with ISO 32 oil. Use correct oil for climate conditions.
+50 to +120 Degrees F - Grade ISO 32
Below + 70 Degrees F - Grade ISO 15 or MIL-H-5606
 See TABLES 40-1 & 40-2 for recommended brands of ISO 32 & ISO 15 oils.

1. Unbolt and remove pump cover (FIG. 39-1).
2. Check the hydraulic fluid level in reservoir as follows. With Liftgate stowed, or platform at vehicle bed height, level should be as shown in FIG. 39-2.

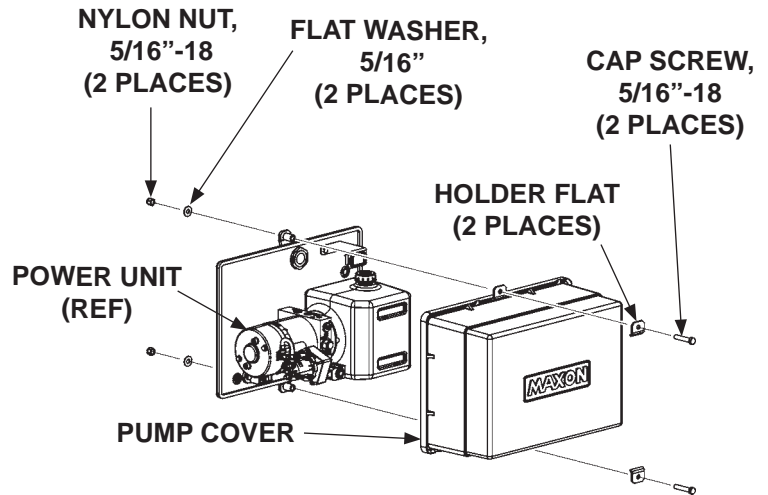

UNBOLTING PUMP COVER
FIG. 39-1

3. If needed, add fluid to the reservoir as follows. Remove filler cap (FIG. 39-2). Fill the reservoir with hydraulic fluid to level shown in FIG. 39-2. Reinstall filler cap (FIG. 39-2).

CAUTION

Pump cover must be correctly secured to prevent it from becoming a hazard. To secure pump cover, the holder flats must butt against pump cover as shown in the illustration.

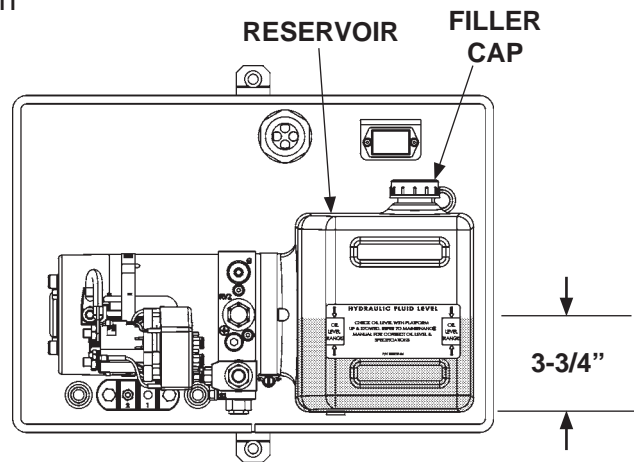

POWER UNIT FLUID LEVEL
FIG. 39-2

4. Bolt on the pump cover as shown in FIG. 39-1. Torque the bolts (cap screws) to 10-14 lb-in.

STEP 8 - CHECKING HYDRAULIC FLUID - Continued

ISO 32 HYDRAULIC OIL	
RECOMMENDED BRANDS	PART NUMBER
ROSEMEAD	ROSEMEAD MV150
EXXONMOBIL	MOBIL DTE 10 EXCEL 32
EXXONMOBIL	UNIVIS N-32, DTE-24
CHEVRON	CHEVRON AV MV32
CHEVRON	HIPERSYN 32
U.S. PRESTIGE	PRESTIGE AW HVI 32
KENDALL	GOLDEN MV
SHELL	TELLUS S2 VX 32

TABLE 40-1

ISO 15 OR MIL-H-5606 HYDRAULIC OIL	
RECOMMENDED BRANDS	PART NUMBER
CHEVRON	FLUID A, AW-MV-15
KENDALL	GLACIAL BLU
SHELL	TELLUS S2 VX 15
EXXONMOBIL	UNIVIS HVI-13
PHILLIPS 66	ARCTIC LOW POUR
ROSEMEAD	THS FLUID 17111

TABLE 40-2

STEP 9 - CONNECT POWER CABLE TO BATTERY

NOTE: MAXON recommends using dielectric grease on battery cable connections.

1. Remove nut from negative (-) battery terminal. Disconnect negative (-) battery cable (FIG. 41-1).

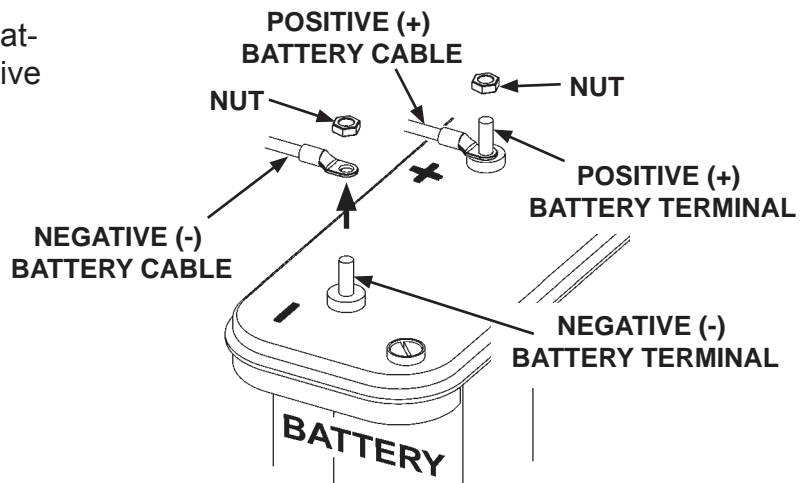

DISCONNECTING (-) BATTERY CABLE
FIG. 41-1

2. Remove nut from positive (+) battery terminal (FIG. 41-1).

3. Connect fused positive (+) cable to positive (+) battery terminal (FIG. 41-2). Then, reinstall nut on positive (+) battery terminal (FIG. 41-2).

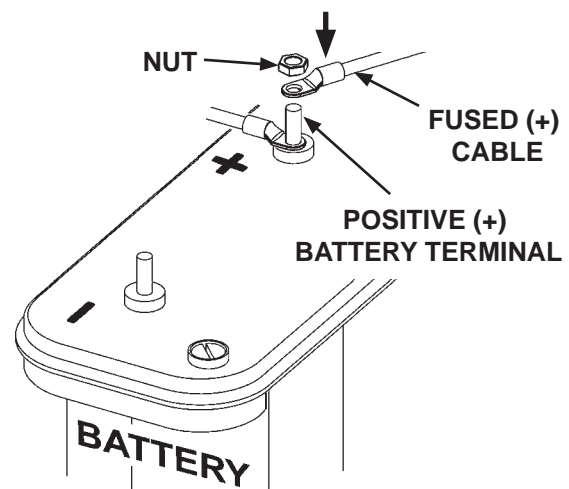

CONNECTING FUSED (+) CABLE
FIG. 41-2

4. Reconnect negative (-) battery cable to negative (-) battery terminal (FIG. 41-3). Then, reinstall nut on negative (-) battery terminal (FIG. 41-3).

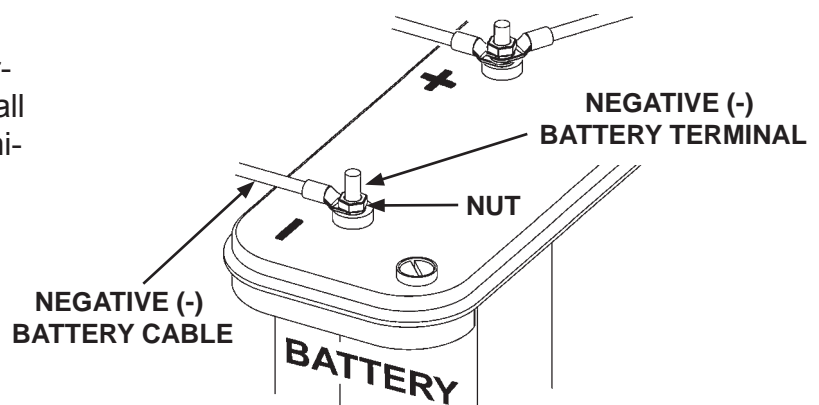

RECONNECTED BATTERY CABLES
FIG. 41-3

STEP 10 - REMOVE LOCKING BRACKETS & CHECK FOR INTERFERENCE

CAUTION

Do not fully pressurize the system in this step. Fully pressurize the system and check for hydraulic leaks after Liftgate is fully welded.

1. Push control switch to **UP** position and hold just enough time to pressurize hydraulic system. Release control switch. Hydraulic system is ready.
2. Remove floor jack and hoist supporting Liftgate (**FIG. 42-1**).

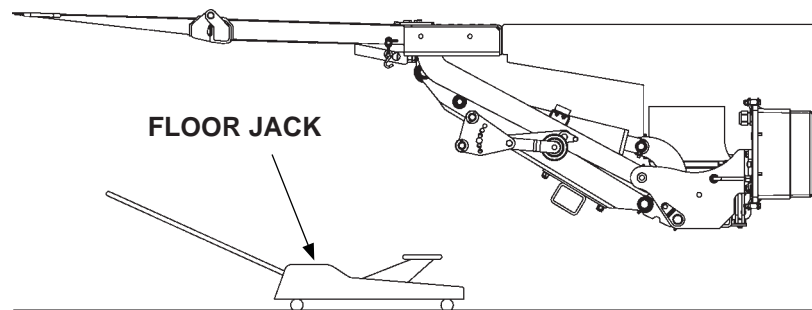

FIG. 42-1

3. Lower platform until shackles touch the ground. Remove both installation brackets from extension plate (**FIG. 42-2**).

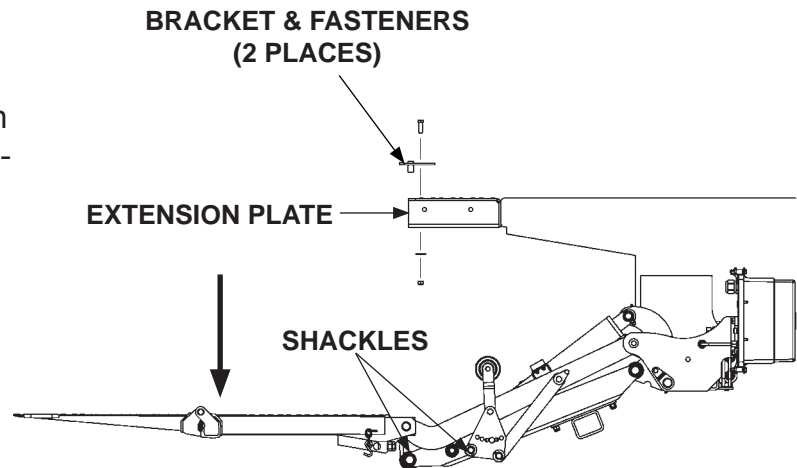
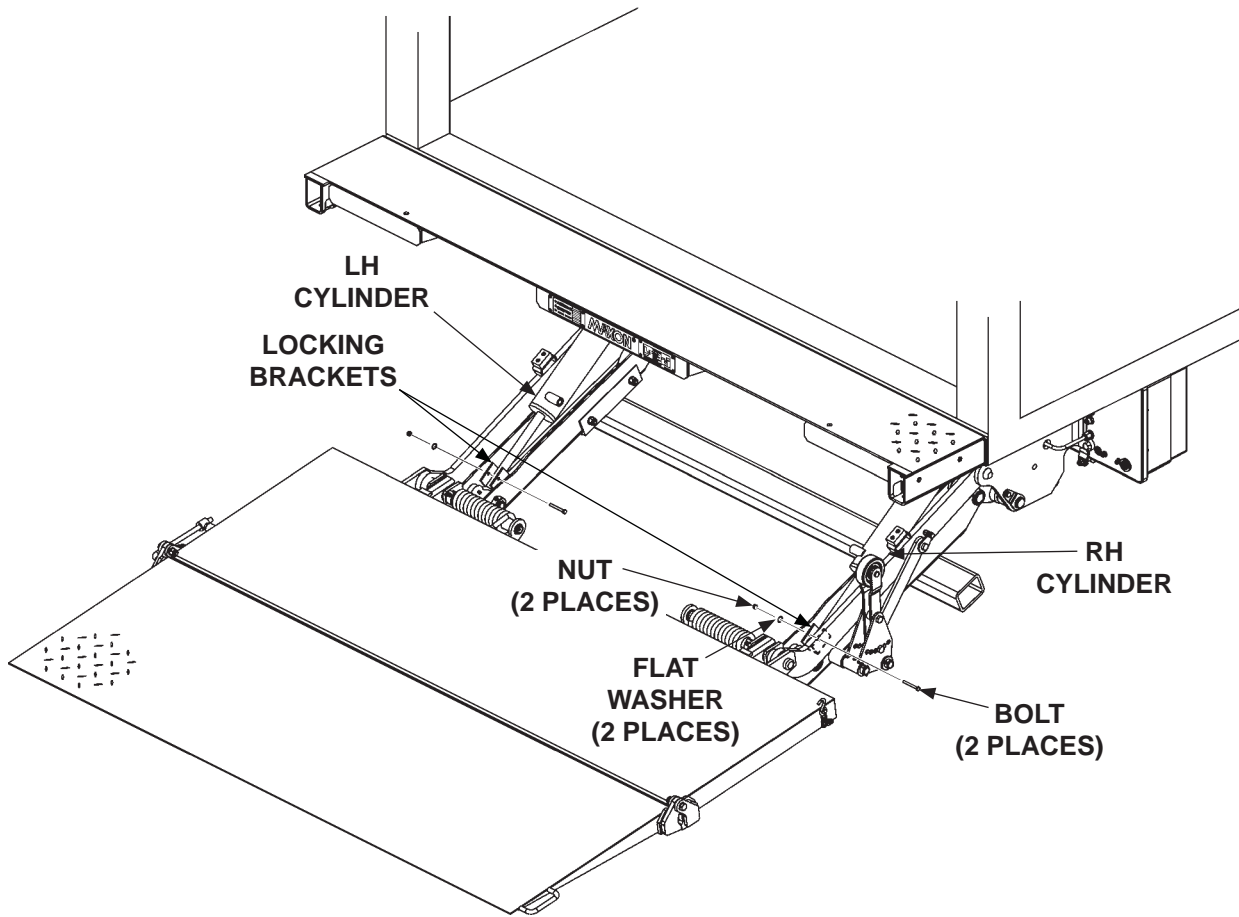

FIG. 42-2

STEP 10 - REMOVE LOCKING BRACKETS & CHECK FOR INTERFERENCE - Continued

NOTE: To operate Liftgate, locking brackets must be removed from cylinders.

4. Remove locking brackets from LH and RH cylinder (**FIG. 43-1**).



REMOVING LOCKING BRACKETS
FIG. 43-1

STEP 10 - REMOVE LOCKING BRACKETS & CHECK FOR INTERFERENCE - Continued

5. Unbolt and discard knuckle down bracket locking bolts from LH and RH sides of Liftgate (FIGS. 44-1 and 44-1A).

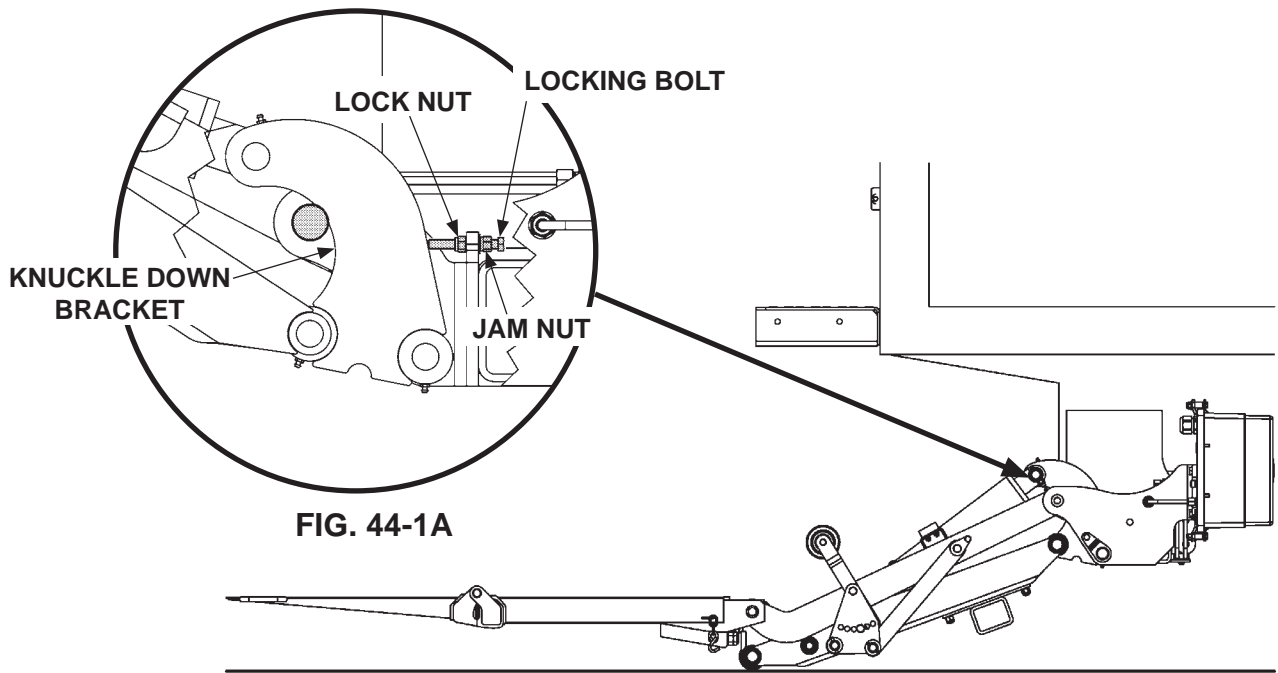

FIG. 44-1A

UNBOLTING KNUCKLE DOWN BRACKET LOCKING BOLTS
(RH SIDE SHOWN)

FIG. 44-1

STEP 10 - REMOVE LOCKING BRACKETS & CHECK FOR INTERFERENCE - Continued

NOTE: Correct any interference problems before continuing with installation.

6. Raise platform to bed height (**FIG. 45-1**). Then, lower platform to the ground (**FIG. 45-2**). Look for any interference between liftgate and vehicle as platform is raised and lowered.

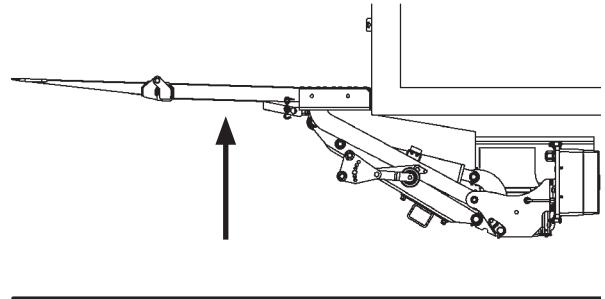

**RAISING PLATFORM
FIG. 45-1**

NOTE: If there is air in the hydraulic fluid, allow the air to dissipate before raising platform.

7. If the platform lowers with a “jerking” motion, bleed air from the hydraulic system by doing the following. Push the control switch to the **DOWN** position until you hear air escaping into the hydraulic fluid reservoir. Then, raise the platform (**FIG. 45-1**). Repeat this step until there is no air left in the system and platform lowers smoothly (**FIG. 45-2**).

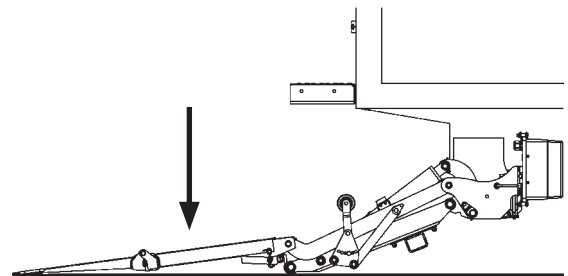

**LOWERING PLATFORM
FIG. 45-2**

STEP 10 - REMOVE LOCKING BRACKETS & CHECK FOR INTERFERENCE - Continued

NOTE: Correct any fit and interference problems before continuing with installation.

8. Raise platform to bed height (**FIG. 46-1**). Check for 3/4" gap between heel of platform and edge of extension plate (**FIG. 46-1**).

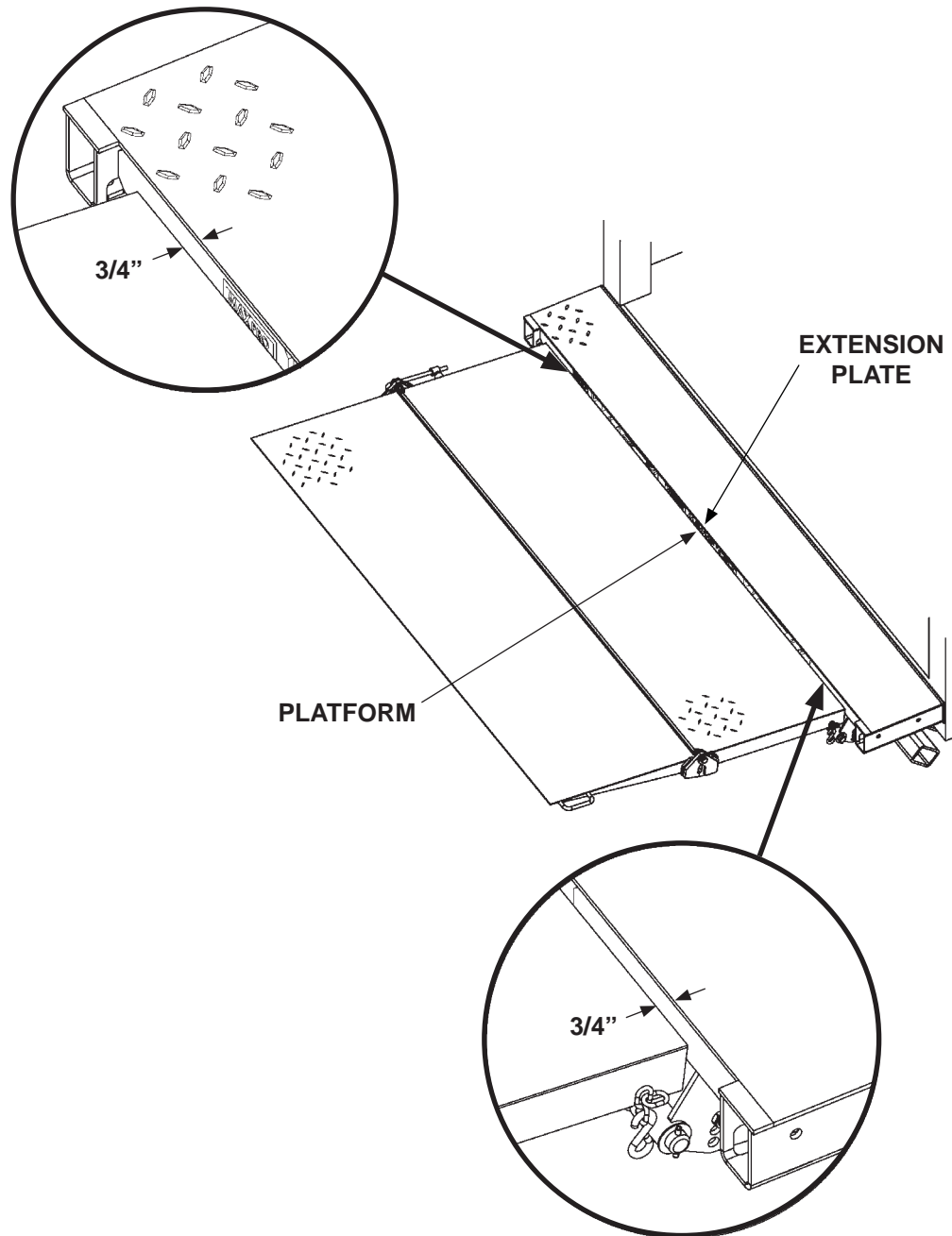

**CHECKING GAP BETWEEN PLATFORM
& EXTENSION PLATE
FIG. 46-1**

STEP 10 - REMOVE LOCKING BRACKETS & CHECK FOR INTERFERENCE - Continued

NOTE: Correct any fit and interference problems before continuing with installation.

9. Ensure top surface of platform and extension plate are flush at the RH and LH sides of platform (FIGS. 47-1 and 47-2). The maximum allowable height difference is 1/8" at the LH and RH sides, and 1/4" from side to side across the width of the platform.

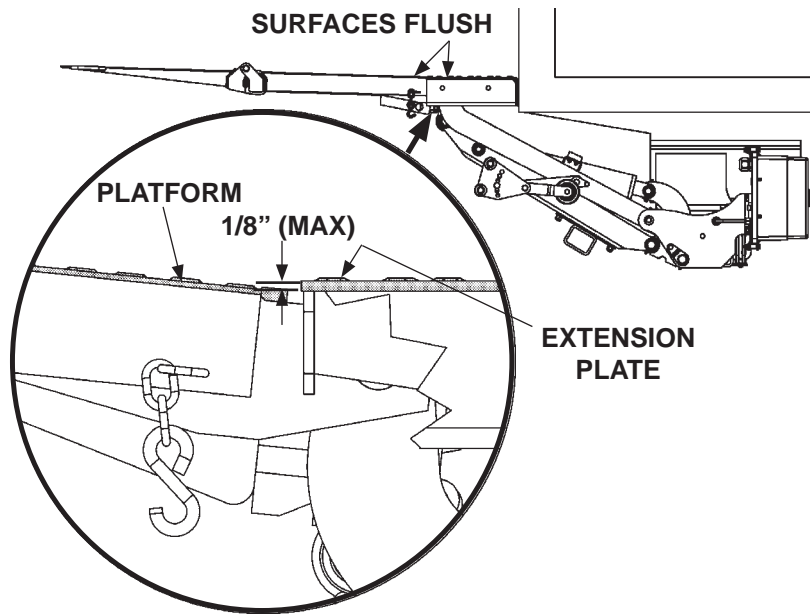

DIFFERENCE IN HEIGHT FOR TOP OF PLATFORM & EXTENSION PLATE (RH VIEW)
FIG. 47-1

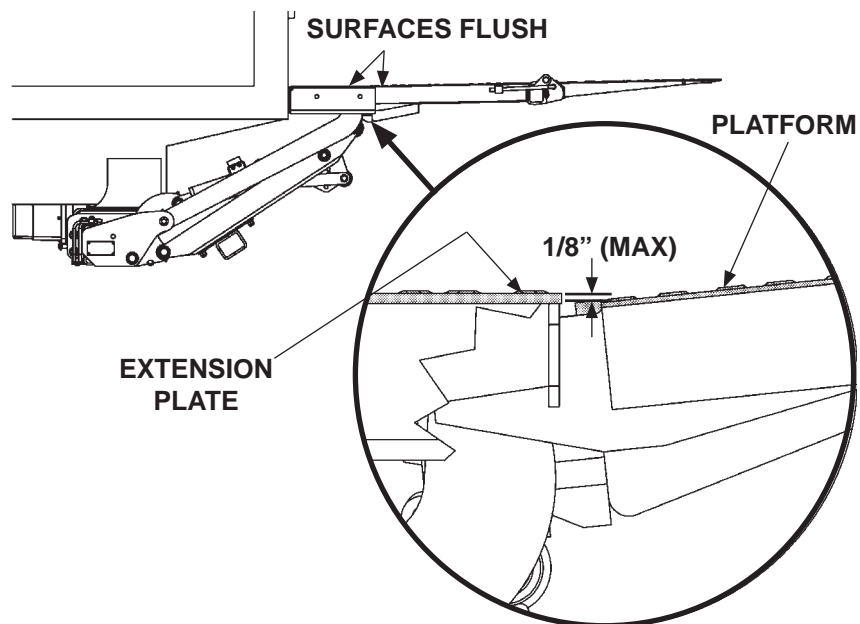

DIFFERENCE IN HEIGHT FOR TOP OF PLATFORM & EXTENSION PLATE (LH VIEW)
FIG. 47-2

STEP 11 - ADJUST PLATFORM OPENER

To adjust openers, remove cap screw and hex nut from opener bracket (FIG. 48-1). Rotate opener assembly to the correct hole position (FIG. 48-2 and TABLE 48-1). Reinstall cap screw and nut.

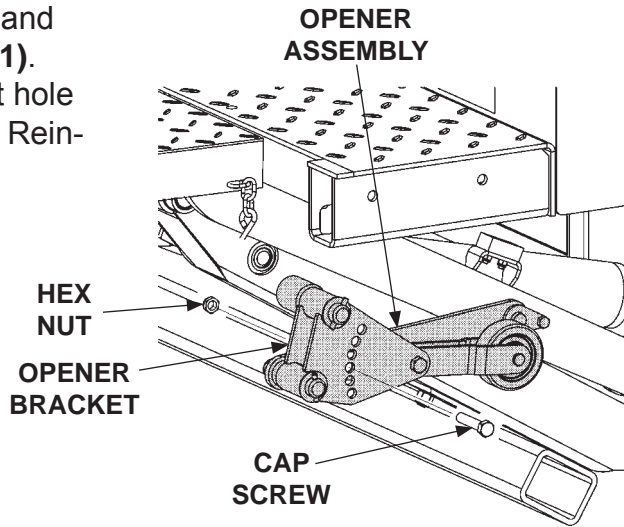

REMOVING BOLT FROM OPENER BRACKET
FIG. 48-1

NOTE: Hole positions are approximate and may have to be adjusted up 1 hole or down 1 hole for best opener function on your vehicle.

TRUCK BED HEIGHT	HOLE NUMBER
38" - 43"	1
43" - 44"	4
44" - 45"	5
45" - 46"	6

**BOLT HOLE CHART FOR 38"- 46"
BED HEIGHTS (24" + 24" PLATFORMS)
TABLE 48-1**

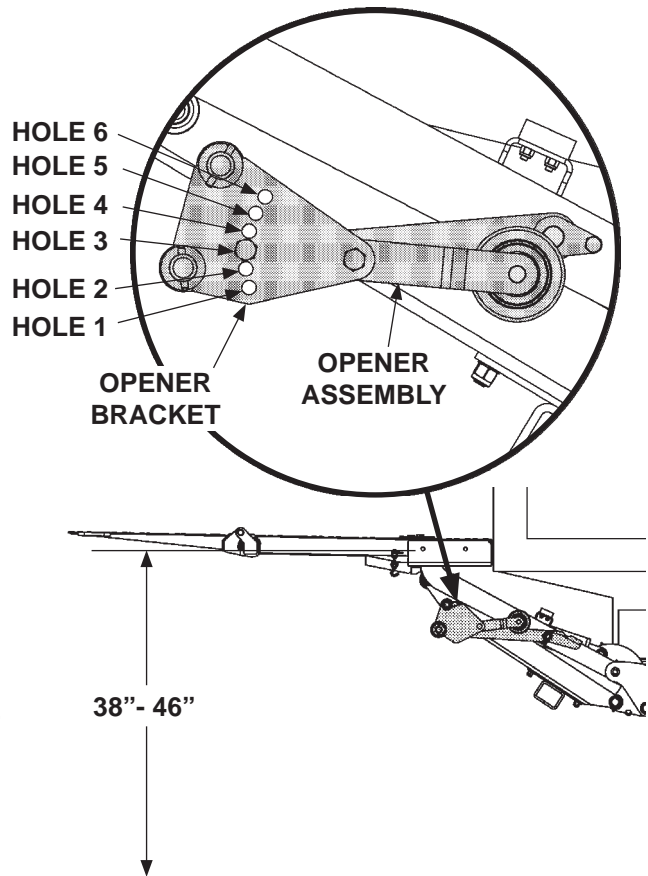

**POSITIONING OPENER FOR
38"- 46" BED HEIGHT
FIG. 48-2**

STEP 12 - ADJUST PLATFORM (IF REQUIRED)

NOTE: Before doing the following procedures, make sure vehicle is parked on level ground.

1. With the platform and flipover unfolded, raise platform to bed level (**FIG. 49-1**). Measure how much the outboard edge of platform rises above floor level (**FIG. 49-1**). The outboard edge must be 1/2" to 2" above floor level (**FIG. 49-1**). If indication is correct, Liftgate is installed correctly and no adjustment is needed. If the outboard edge is more than 2" above floor level, turn both RH and LH platform adjustment bolts counter-clockwise until the platform edge is within specification (**FIG. 49-2**).

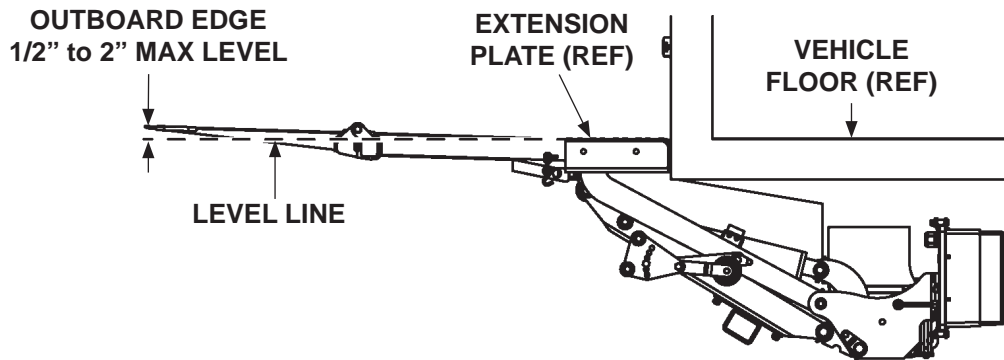

PLATFORM EDGE AT OR ABOVE BED LEVEL
FIG. 49-1

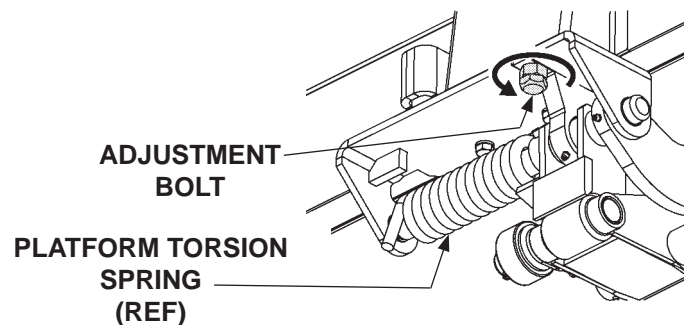

ADJUSTING PLATFORM (IF TOO HIGH)
(RH ADJUSTMENT BOLT SHOWN)
FIG. 49-2

STEP 12 - ADJUST PLATFORM (IF REQUIRED) - Continued

2. If the tip of the platform is less than 1/2" above floor level (**FIG. 50-1**), turn both RH and LH platform adjustment bolts clockwise until the platform tip is 1/2" to 2" above floor level (**FIGS. 50-1 and 50-2**).

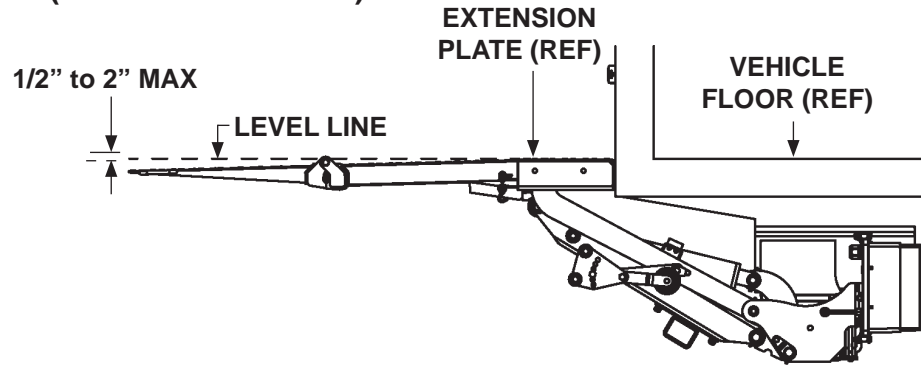

PLATFORM EDGE BELOW BED LEVEL
FIG. 50-1

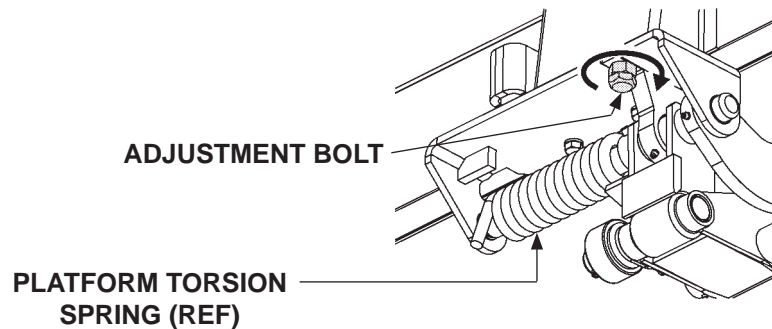

ADJUSTING PLATFORM (IF TOO LOW)
(RH ADJUSTMENT BOLT SHOWN)
FIG. 50-2

STEP 13 - FINISH WELDING LIFTGATE TO VEHICLE

CAUTION

Prevent damage to hydraulic hoses. Before welding next to hydraulic hoses, protect the hoses with a heat-resistant cover such as a welding blanket.

Weld each of the two mounting plates as shown in FIG. 51-1.

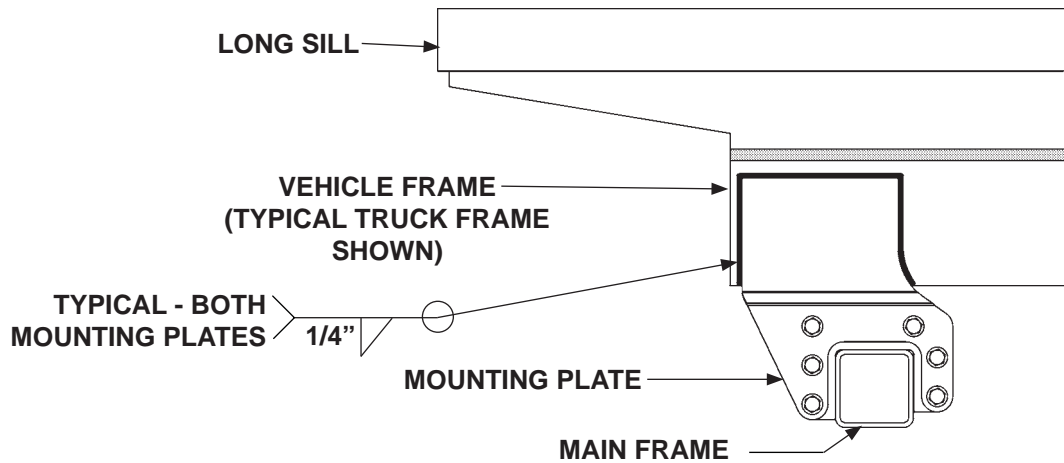

MOUNTING PLATE (GALVANIZED) WELDED TO TRUCK FRAME
FIG. 51-1

STEP 14 - BOLT OPTIONAL STEPS TO EXTENSION PLATE

1. Lower platform to the ground (FIG. 52-1).

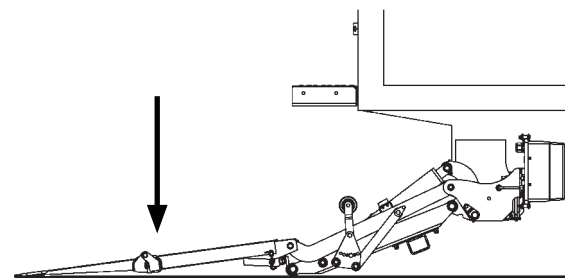

PLATFORM LOWERED TO GROUND
FIG. 52-1

⚠ WARNING
To prevent accidental personal injury and equipment damage, disconnect (-) battery cable and (+) cable from battery.

2. Disconnect power to the pump by disconnecting negative (-) and positive (+) cables from battery (FIG. 52-2). Reinstall nuts on negative (-) and positive (+) battery terminals.

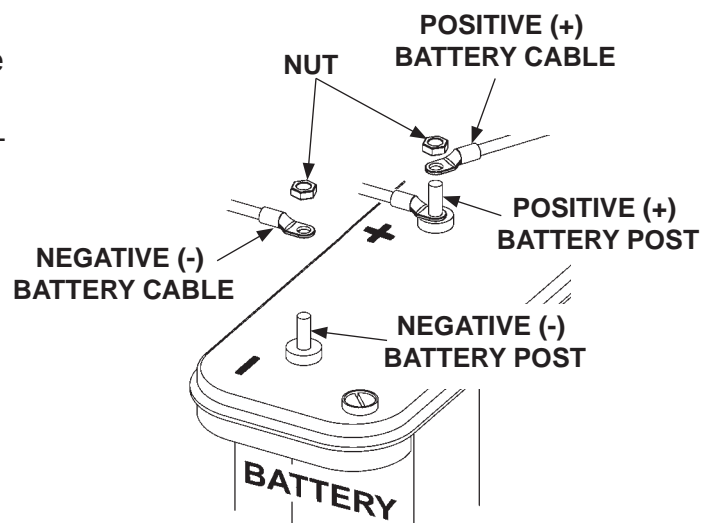

DISCONNECTING BATTERY POWER
FIG. 52-2

STEP 14 - BOLT OPTIONAL STEPS TO EXTENSION PLATE - Continued

CAUTION

To prevent interference with Liftgate and possible damage, maintain 90° angle between steps and extension plate. Tighten bolts only in the order shown in illustration.

NOTE: If 102" extension kit is to be installed for 102" wide vehicle, install the extension kit before installing the steps.

- Line up the LH step (Kit item) on LH side of the extension plate. Bolt step to extension plate (**FIG. 53-1**). Tighten bolts **1, 2, 3** and **4** in the numbered order shown in **FIG. 53-1**. Then, torque each bolt and lock nut to **105 lb-ft** in the same order.

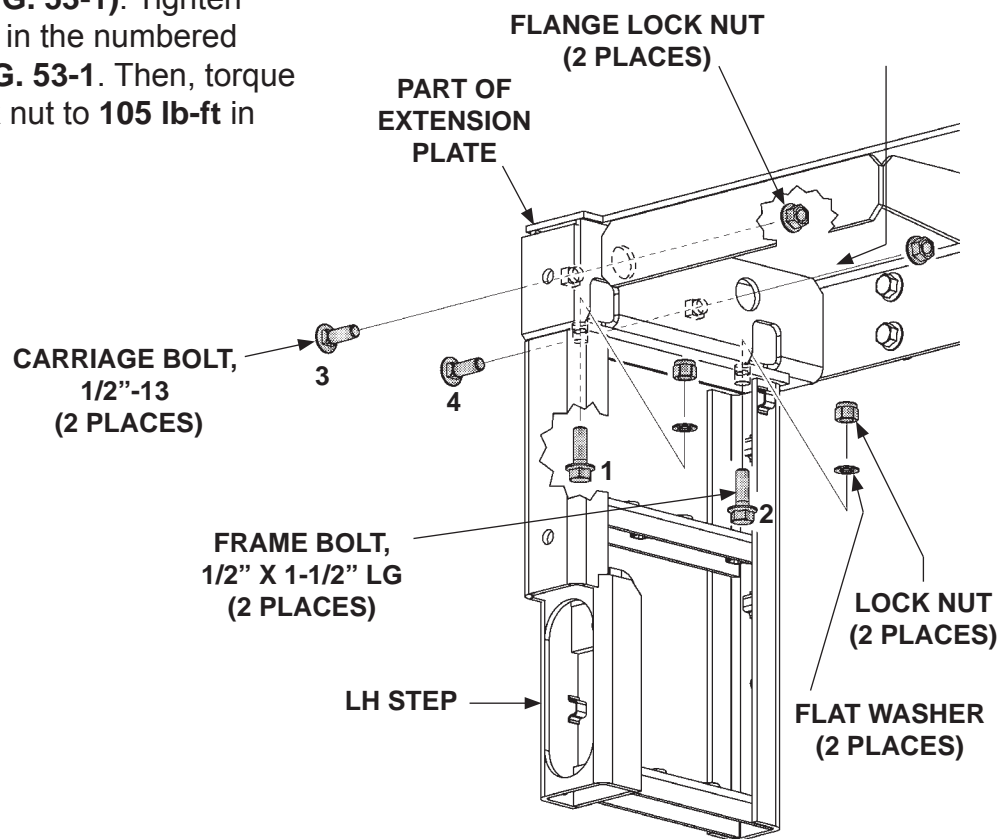

**BOLTING STEP TO EXTENSION PLATE
(LH DUAL STEP SHOWN)
FIG. 53-1**

STEP 14 - BOLT OPTIONAL STEPS TO EXTENSION PLATE - Continued

4. Bolt the step support (Kit item) to mounting channel (Kit item) (FIG. 54-1).

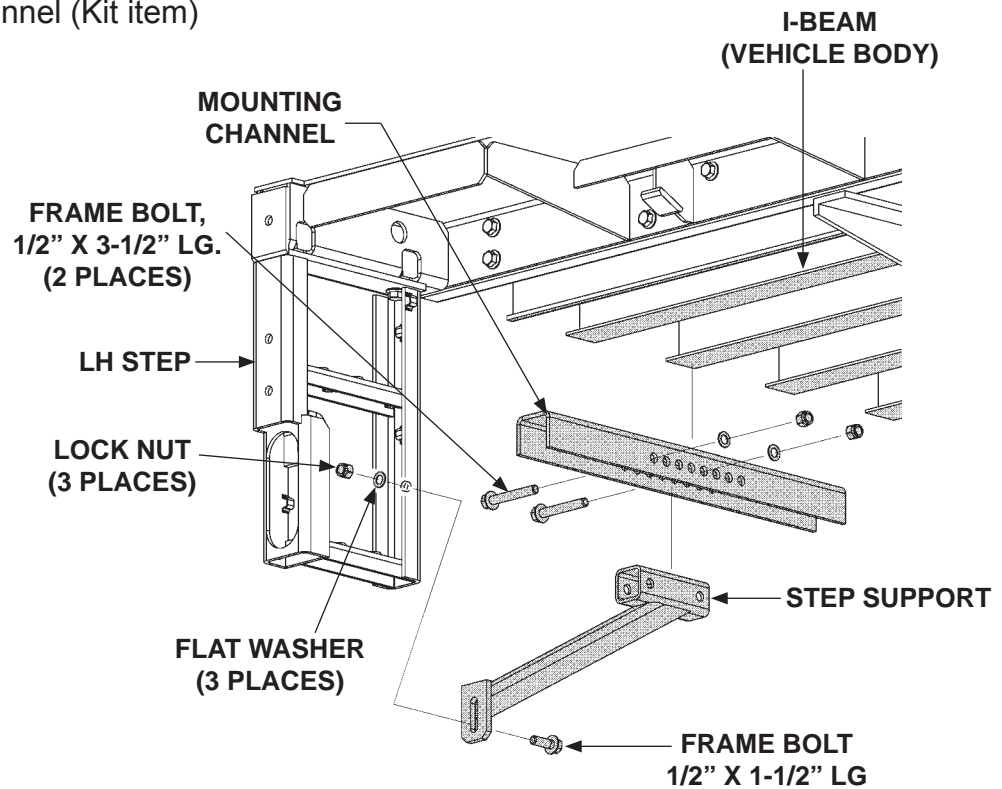

**BOLTING SUPPORT TO MOUNTING CHANNEL AND STEP
(LH DUAL STEP & SUPPORT SHOWN)**

FIG. 54-1

5. Butt the flat part of the mounting channel against bottom of vehicle rear sill and I-beams. Then, butt the step support against back of the step (FIG. 54-1).
6. Ensure slotted hole in the step support is lined up with the hole on the step (FIG. 54-1). Then, bolt the support to step (FIG. 54-1). Torque the lock nuts (FIG. 54-1) to 105 lb-ft.

STEP 14 - BOLT OPTIONAL STEPS TO EXTENSION PLATE - Continued

NOTE: Before welding mounting channel to vehicle body, ensure step is straight and steps are in vertical position.

7. Weld the flat part of the mounting channel to vehicle body as shown in **FIG. 55-1**.

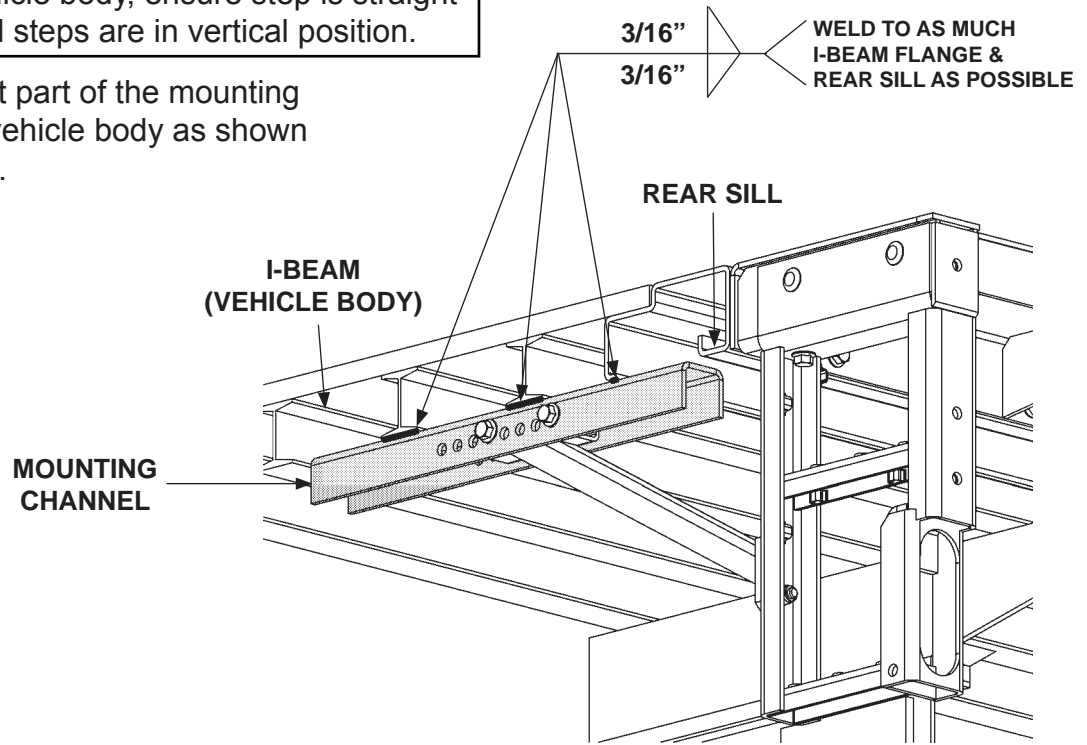

**WELDING FLAT OF MOUNTING CHANNEL TO
VEHICLE BODY (LH DUAL STEP SHOWN)
FIG. 55-1**

8. Attach bumpers (if equipped) to steps as shown in **FIG. 55-2**.

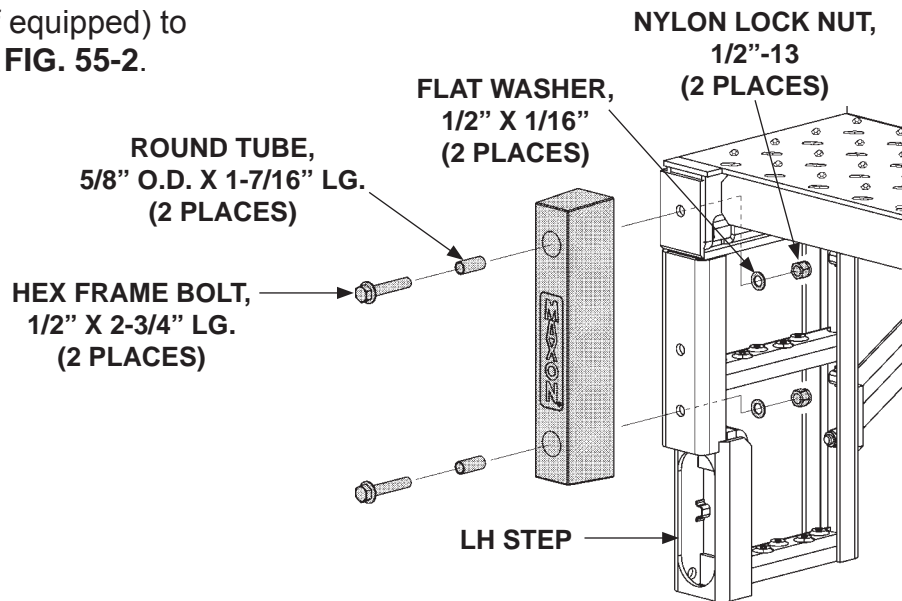

**BOLTING-ON BUMPERS (IF EQUIPPED)
FIG. 55-2**

STEP 14 - BOLT OPTIONAL STEPS TO EXTENSION PLATE - Continued

- Repeat instructions **3 through 8** for RH step. Use the RH step assembly (Kit item).
- Reconnect power to the pump by reconnecting positive (+) and negative (-) cables to battery (**FIG. 56-1**). Reinstall and tighten nut when each battery cable is reconnected.

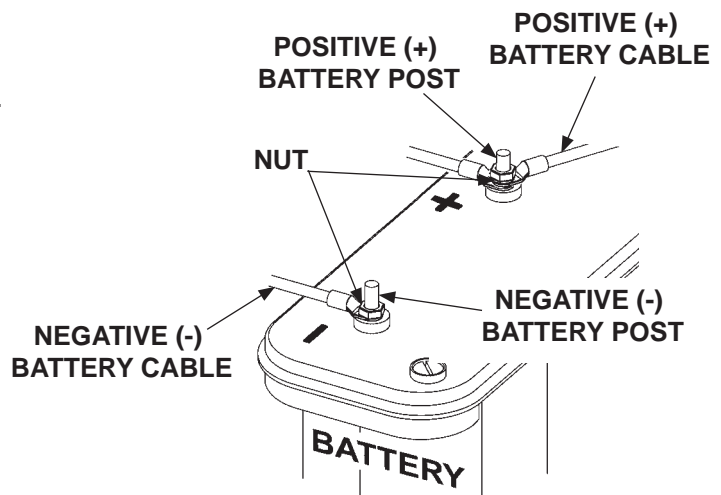

RECONNECTING POWER
FIG. 56-1

STEP 15 - VEHICLE TAILLIGHT POSITIONING

NOTE: Taillights may interfere with Liftgate. Taillights and attaching hardware are not provided with the Liftgate. If needed, install vehicle taillights to comply with state and federal vehicle lighting requirements, such as FMVSS 108.

ATTACH DECALS: MXT-25 & MXT-33

NOTE: Preferred decal layout is shown. Decals on the Liftgate are attached at the factory. If vehicle does not permit this layout, decals in the manual and decal kit must be applied so that they are easily visible when approaching vehicle to operate Liftgate. Use good common sense when locating these decals on vehicle.

NOTE: Ensure there is no residue, dirt or corrosion where decals are attached. If necessary, clean surface before attaching decals.

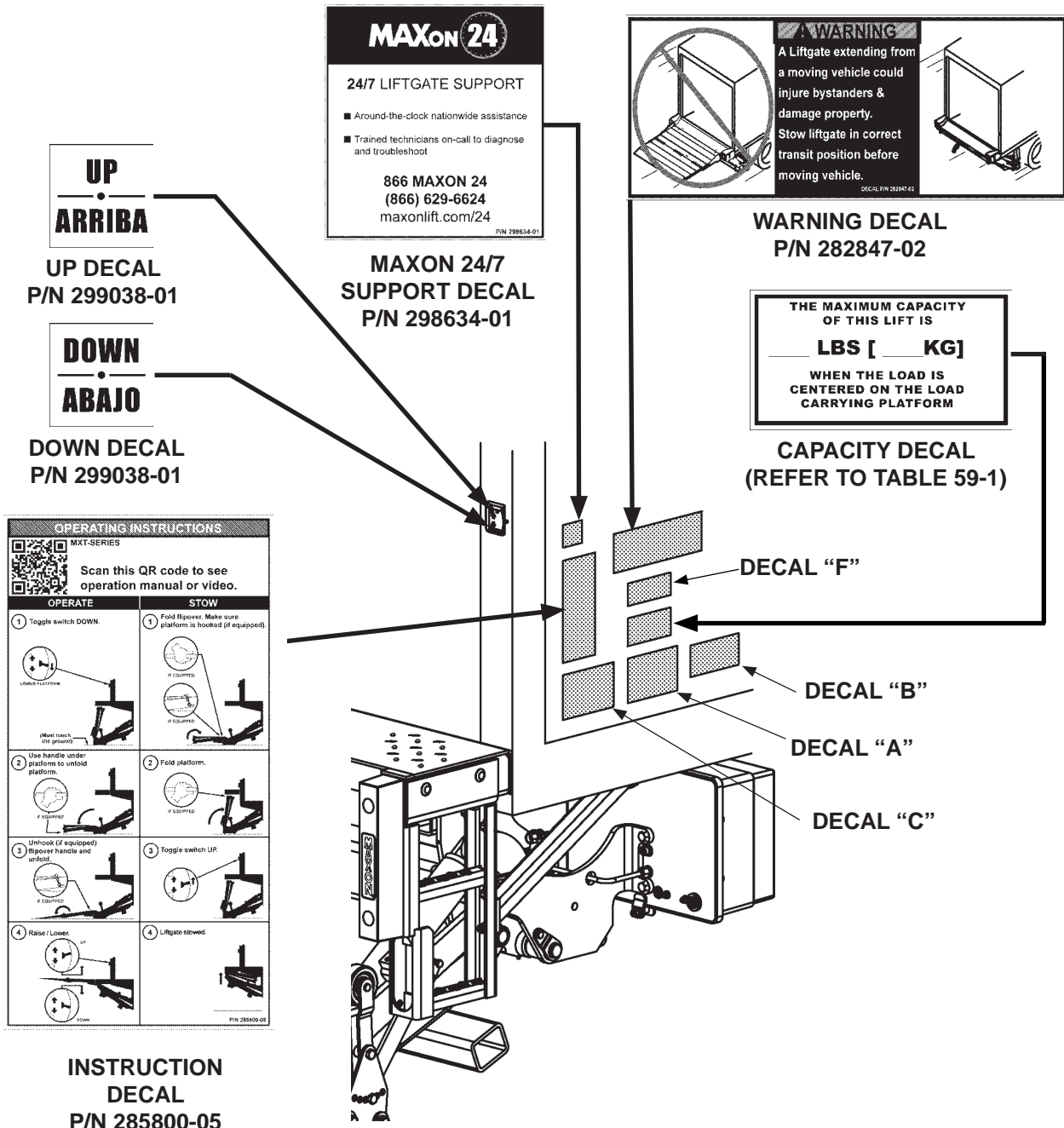

FIG. 58-1

ATTACH DECALS - Continued

SAFETY INSTRUCTIONS

Read all decals and operation manual before operating liftgate.

1. Do not use liftgate unless you have been properly instructed and have read, and are familiar with, the operating instructions.
2. Be certain vehicle is properly and securely braked before using the liftgate.
3. Always inspect this liftgate for maintenance or damage before using it. Do not use liftgate if it shows any sign of damage or improper maintenance.
4. Do not overload
5. Make certain the area in which the platform will open and close is clear before opening or closing the platform.
6. Make certain platform area, including the area in which loads may fall from platform, is clear before and at all times during operation of liftgate.
7. This liftgate is intended for loading and unloading of cargo only. Do not use this liftgate for anything but its intended use.

(A)

WARNING

Read this information carefully.

- Improper operation of this Liftgate can result in serious personal injury. If you do not have a copy of the operating instructions, please obtain them from your employer, distributor, or lessor before you attempt to operate Liftgate.
- If there are signs of improper maintenance, damage to vital parts, or slippery platform surface, do not use the Liftgate until these problems have been corrected.
- If you are using a pallet jack, be sure it can be maneuvered safely.
- Do not operate a forklift on the platform.
- Do not allow any part of yours or your helper's body to be placed under, within, or around any portion of the moving Liftgate, or its mechanisms, or in a position that would trap them between the platform and the ground or truck when the Liftgate is operated.
- If a helper is riding the platform with you, make sure you are both doing so safely and that you are not in danger of coming in contact with any moving or potentially moving obstacles.
- **USE GOOD COMMON SENSE.**
- If load appears to be unsafe, do not lift or lower it.

For a free copy of other manuals that pertain to this model Liftgate, please visit our website at www.maxonlift.com or call Customer Service at (800) 227-4116.

(C)



WARNING

Liftgate hazards can result in crushing or falling.

Keep hands and feet clear of pinch points.

If riding liftgate, make sure load is stable and footing is solid.

P/N 282522-01 (B)

Read and understand all instructions and WARNINGS before use.



CAUTION

Always stand clear of platform area.

(E)

**DECAL SHEET
P/N 282522-01
FIG. 59-1**

MODEL	DECAL P/N	CAPACITY
MXT-25	220382	2500 POUNDS [1134 KG]
MXT-33	220388-02	3300 POUNDS [1500 KG]

**CAPACITY DECALS
TABLE 59-1**

DECALS & PLATES



QR CODE DECAL
299348-09

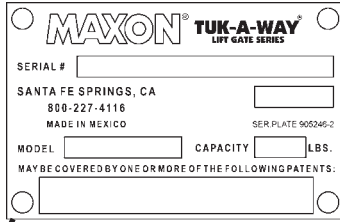

SERIAL PLATE
(REF)



MAXON NAME PLATE
P/N 280004-01

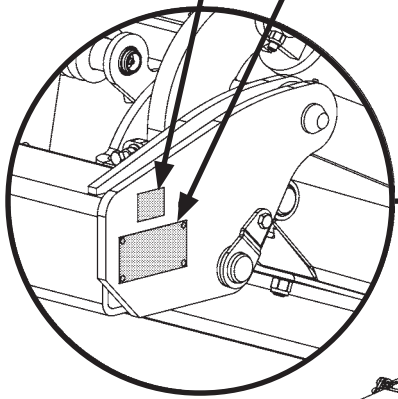

FIG. 60-1A

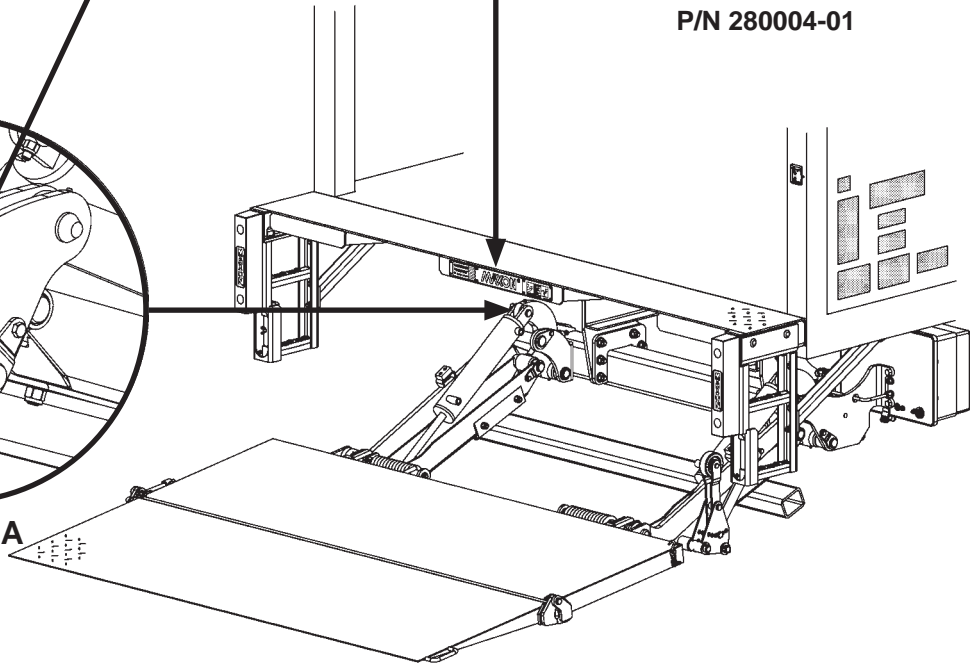

FIG. 60-1

MAXON 11921 Slauson Ave. Santa Fe Springs, CA. 90670 (800) 227-4116 FAX (888) 771-7713

TOUCHUP GALVANIZED FINISH

CAUTION

Damaged cylinder seals and contaminated hydraulic fluid can result from applying galvanize spray to the polished portion of the cylinder rod. To prevent damage, protect the exposed polished portion of the cylinder rod while applying galvanize spray

If bare metal is exposed on galvanized portions of the Liftgate, touch up the galvanized finish. To maintain the protection provided by the original galvanized finish, **MAXON** recommends cold galvanize spray.

SYSTEM DIAGRAMS

PUMP & MOTOR SOLENOID OPERATION (GRAVITY DOWN)

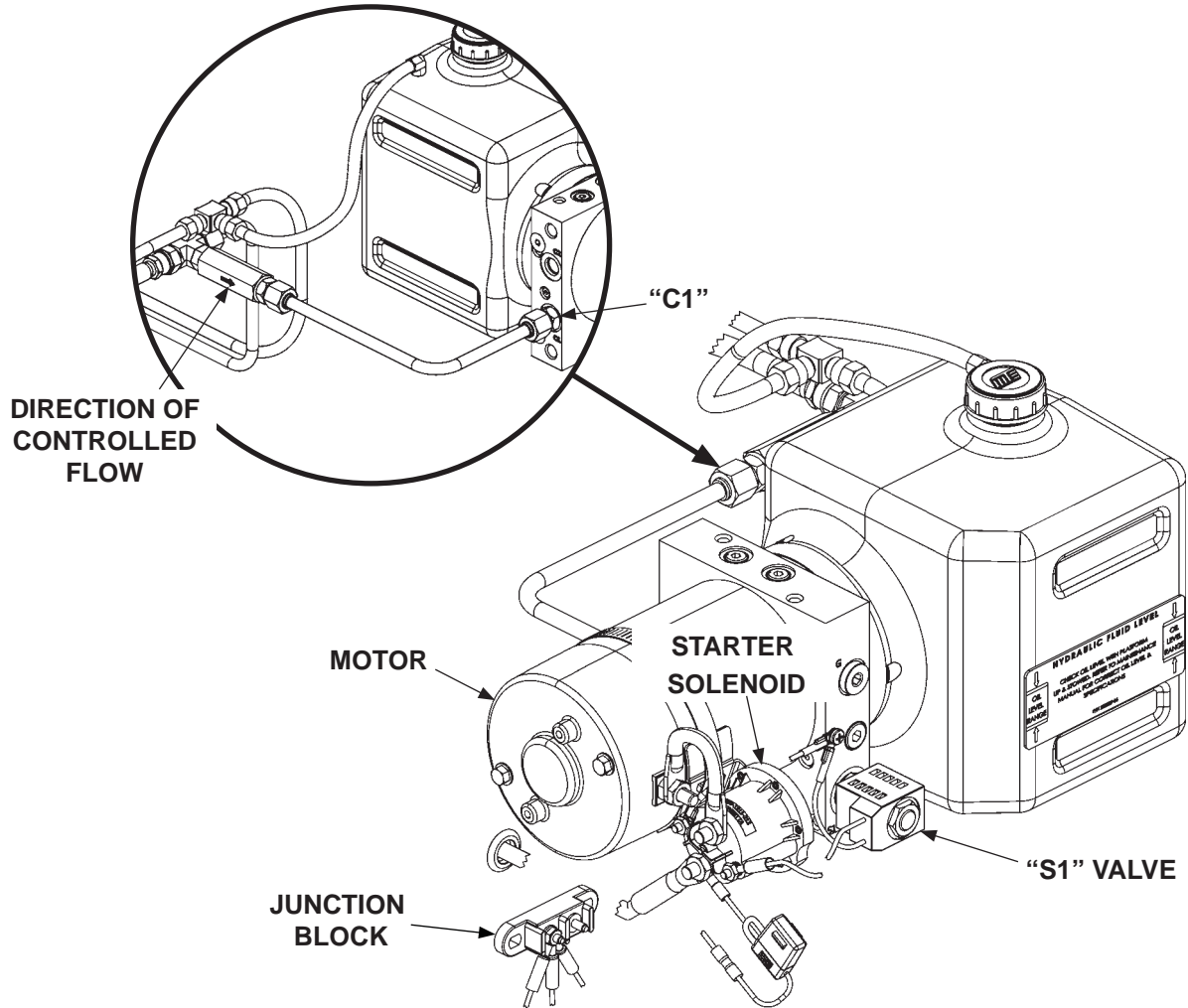

**GRAVITY DOWN POWER UNIT
FIG. 62-1**

POWER UNIT MOTOR & SOLENOID OPERATION				
LIFTGATE FUNCTION	PORT	SOLENOID OPERATION (✓ MEANS ENERGIZED)		
		MOTOR	VALVE "S1"	LOCK VALVE
RAISE	C1	✓	-	-
LOWER		-	✓	✓
REFER TO VALVES SHOWN ON HYDRAULIC SCHEMATIC				

TABLE 62-1

SYSTEM DIAGRAMS - Continued

HYDRAULIC SCHEMATIC (GRAVITY DOWN)

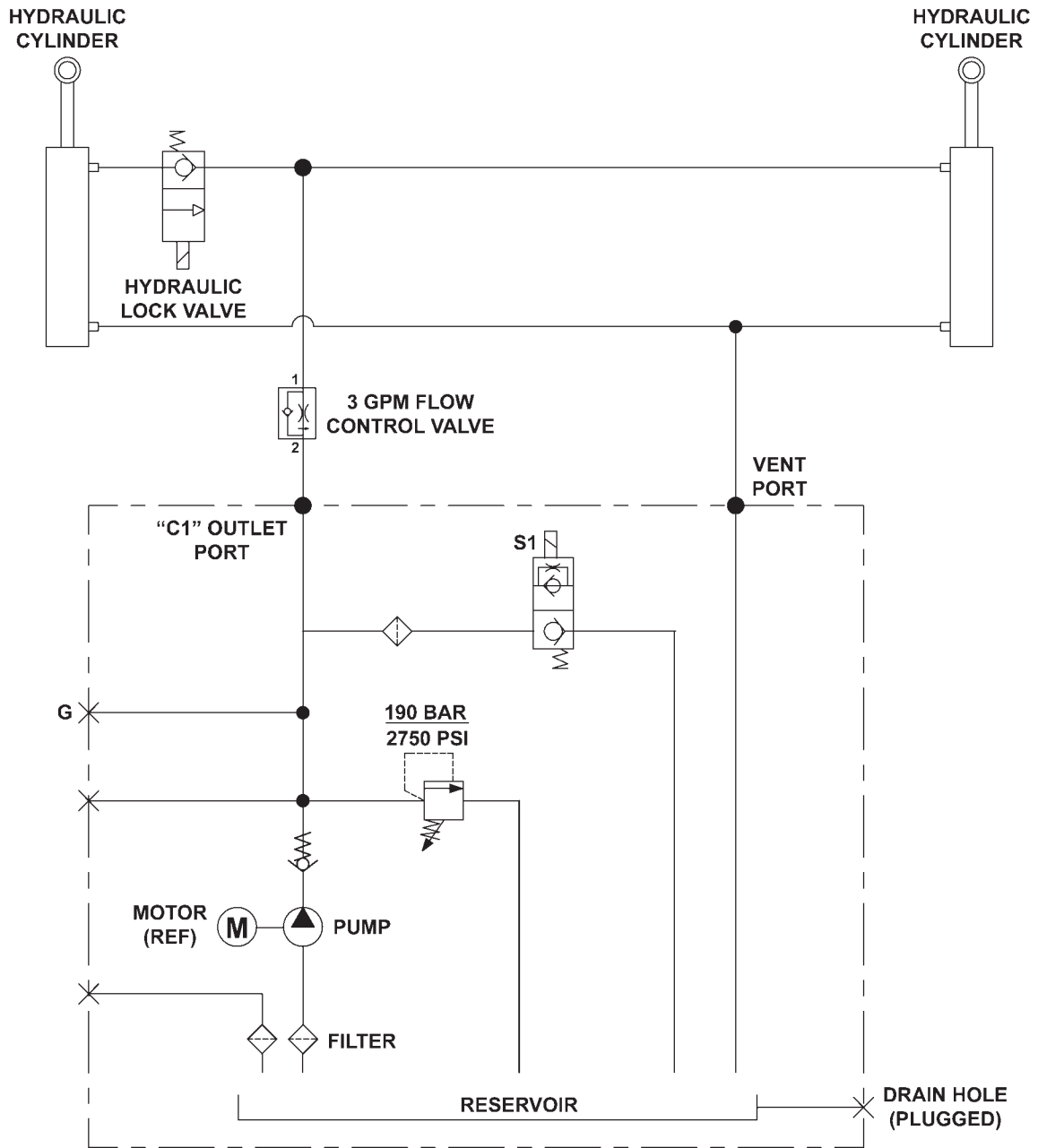

FIG. 63-1

SYSTEM DIAGRAMS - Continued

ELECTRICAL SCHEMATIC (GRAVITY DOWN)

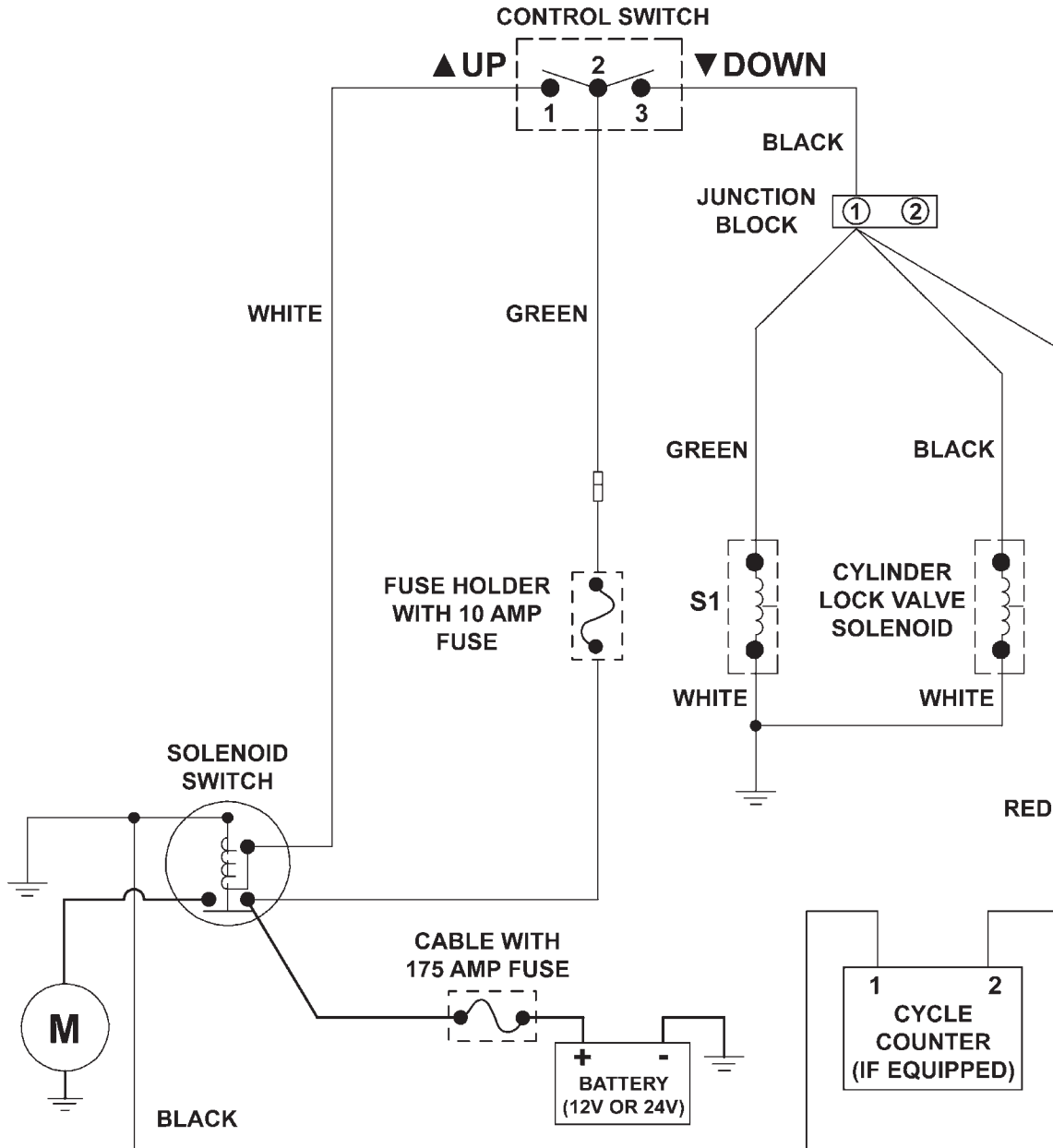
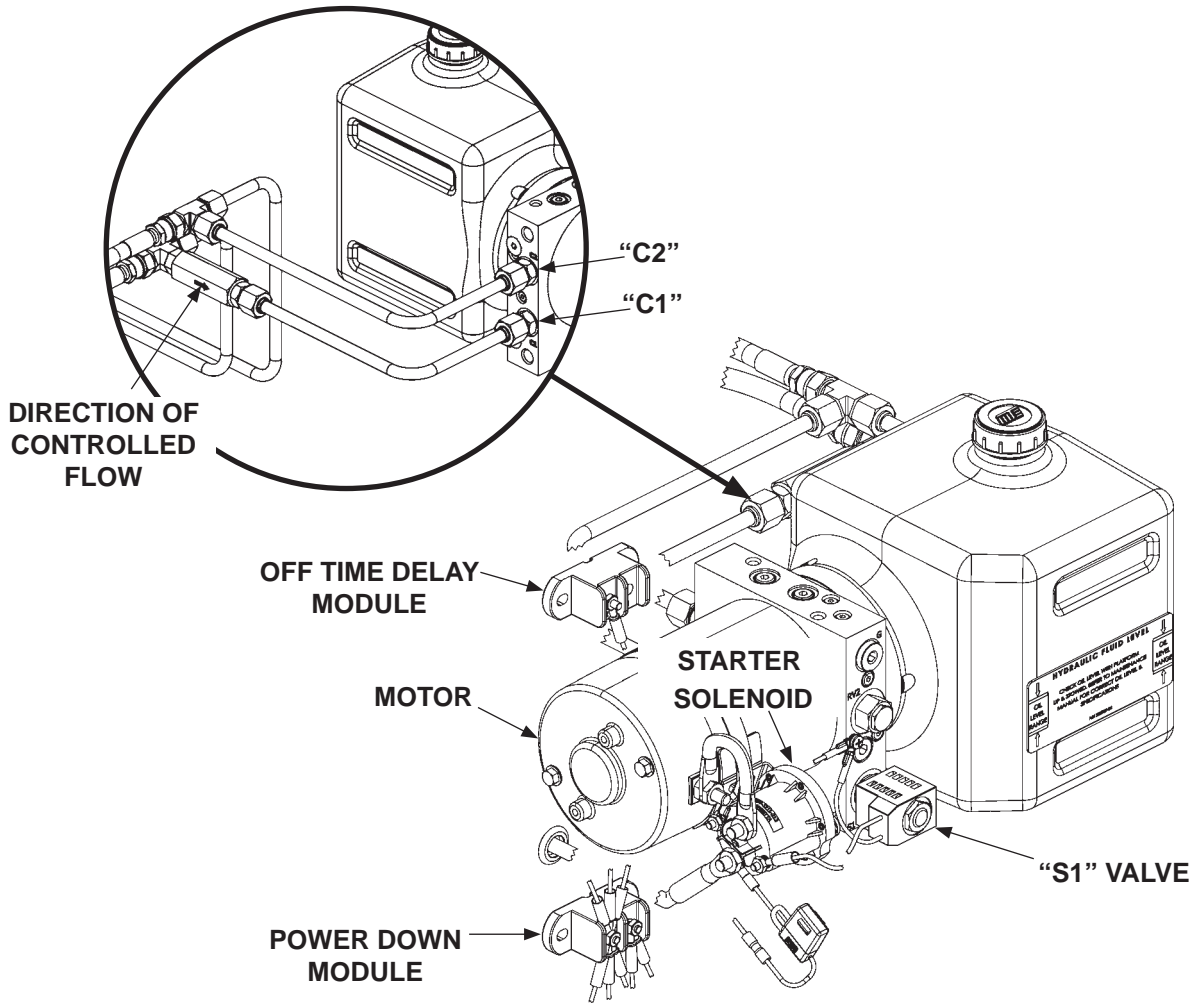

FIG. 64-1

SYSTEM DIAGRAMS - Continued

PUMP & MOTOR SOLENOID OPERATION (POWER DOWN)



POWER DOWN POWER UNIT
FIG. 65-1

POWER UNIT MOTOR & SOLENOID OPERATION						
LIFTGATE FUNCTION	PORT	SOLENOID OPERATION (✓ MEANS ENERGIZED)				
		MOTOR(S)	VALVE "S1"	LH LOCK VALVE	RH LOCK VALVE	OFF TIME DELAY MODULE
RAISE	C1	✓	-	-	-	-
LOWER	C2	✓	✓	✓	✓	✓

REFER TO VALVES SHOWN ON
HYDRAULIC SCHEMATIC

TABLE 65-1

SYSTEM DIAGRAMS - Continued

HYDRAULIC SCHEMATIC (POWER DOWN)

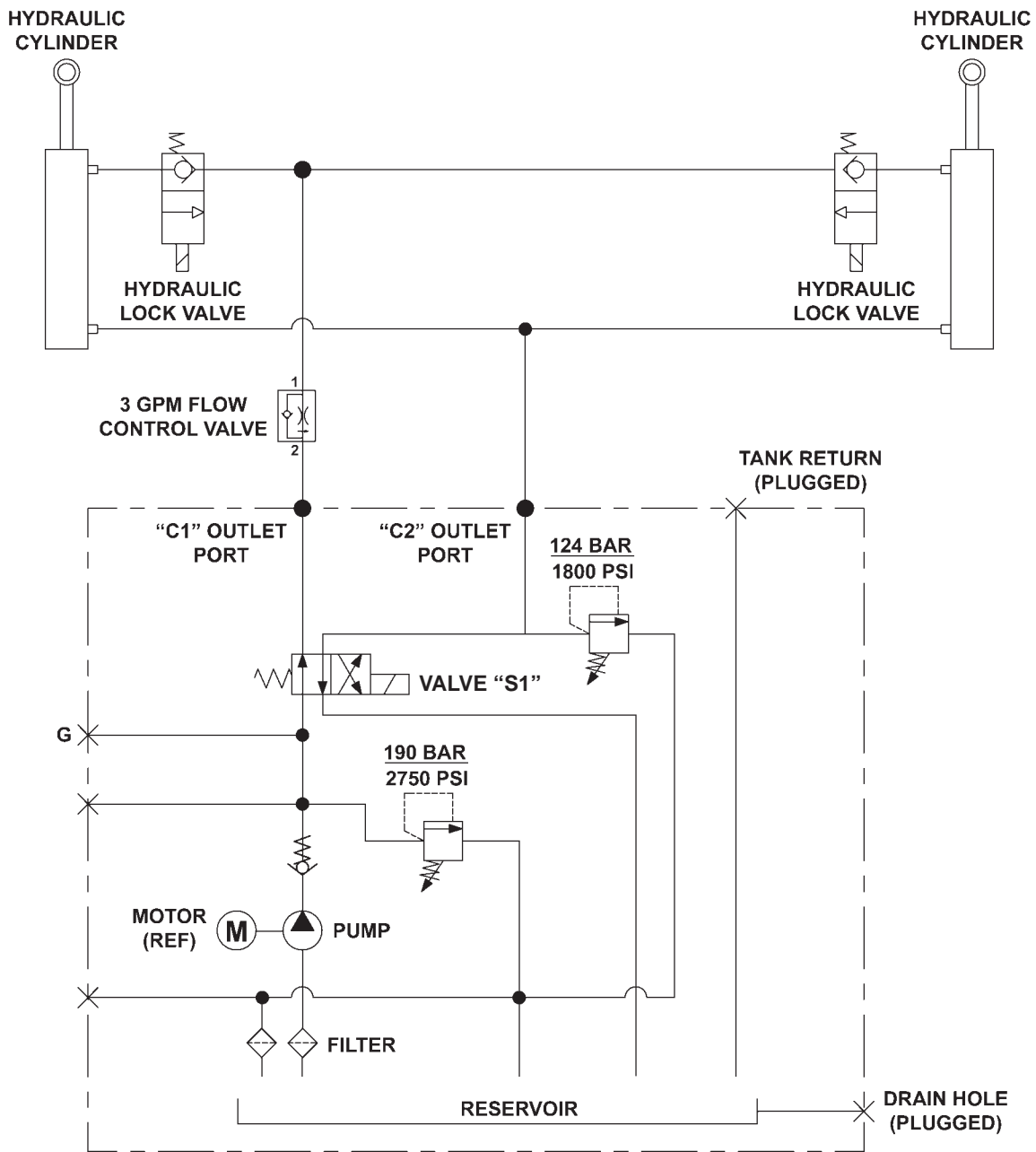

FIG. 66-1

SYSTEM DIAGRAMS - Continued

ELECTRICAL SCHEMATIC (POWER DOWN)

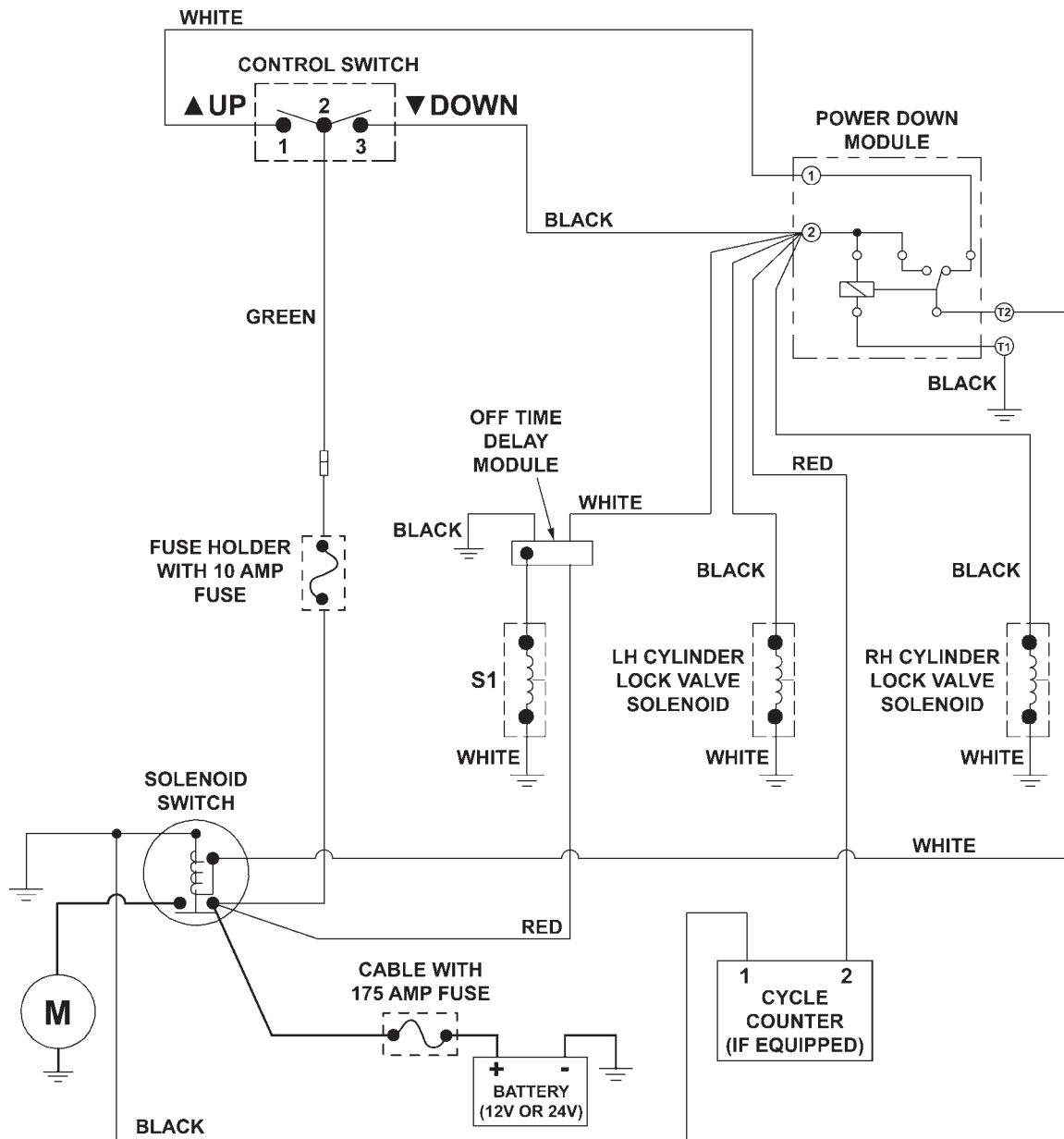
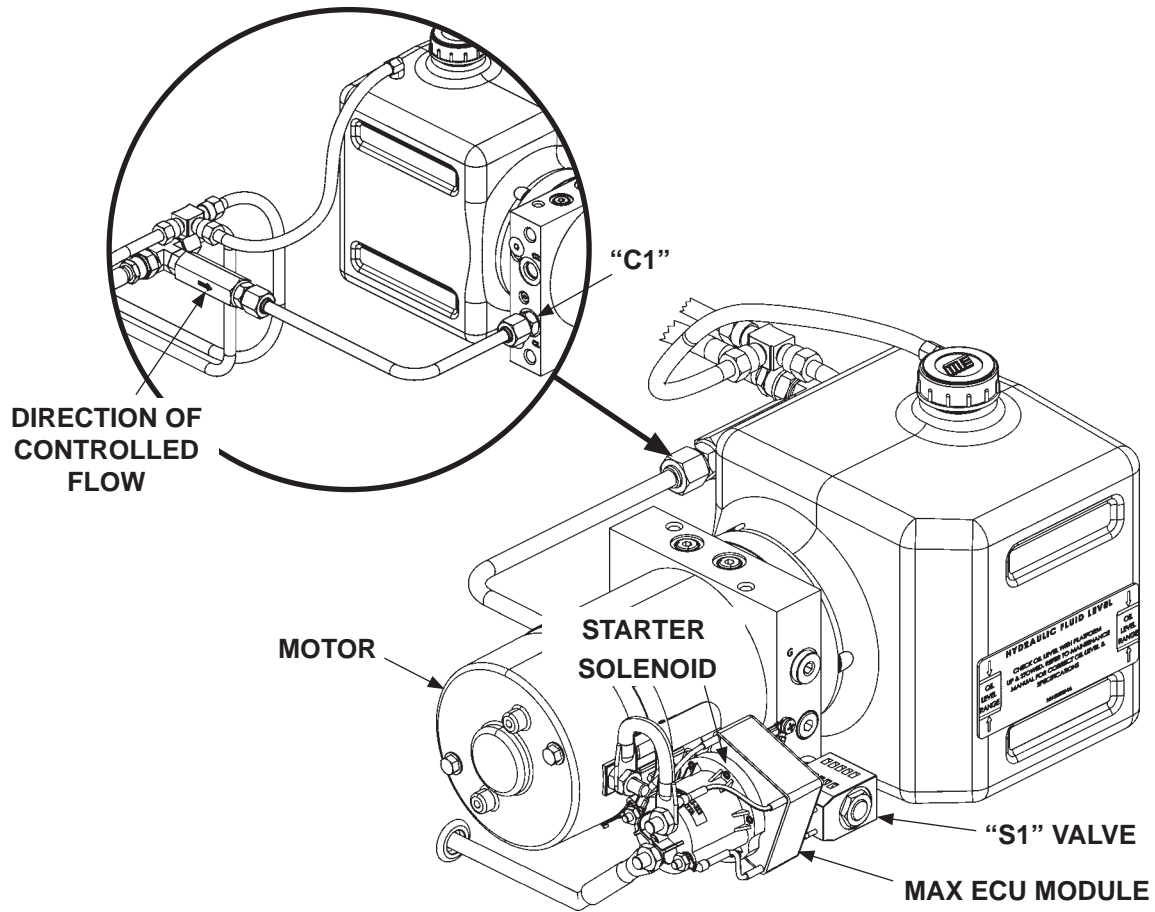

FIG. 67-1

SYSTEM DIAGRAMS - Continued

PUMP & MOTOR SOLENOID OPERATION WITH MAX ECU MODULE (GRAVITY DOWN)



**GRAVITY DOWN POWER UNIT
WITH MAX ECU MODULE
FIG. 68-1**

POWER UNIT MOTOR & SOLENOID OPERATION				
LIFTGATE FUNCTION	PORT	SOLENOID OPERATION (✓ MEANS ENERGIZED)		
		MOTOR	VALVE "S1"	LOCK VALVE
RAISE	C1	✓	-	-
LOWER		-	✓	✓
REFER TO VALVES SHOWN ON HYDRAULIC SCHEMATIC				

TABLE 68-1

SYSTEM DIAGRAMS - Continued

HYDRAULIC SCHEMATIC WITH MAX ECU MODULE (GRAVITY DOWN)

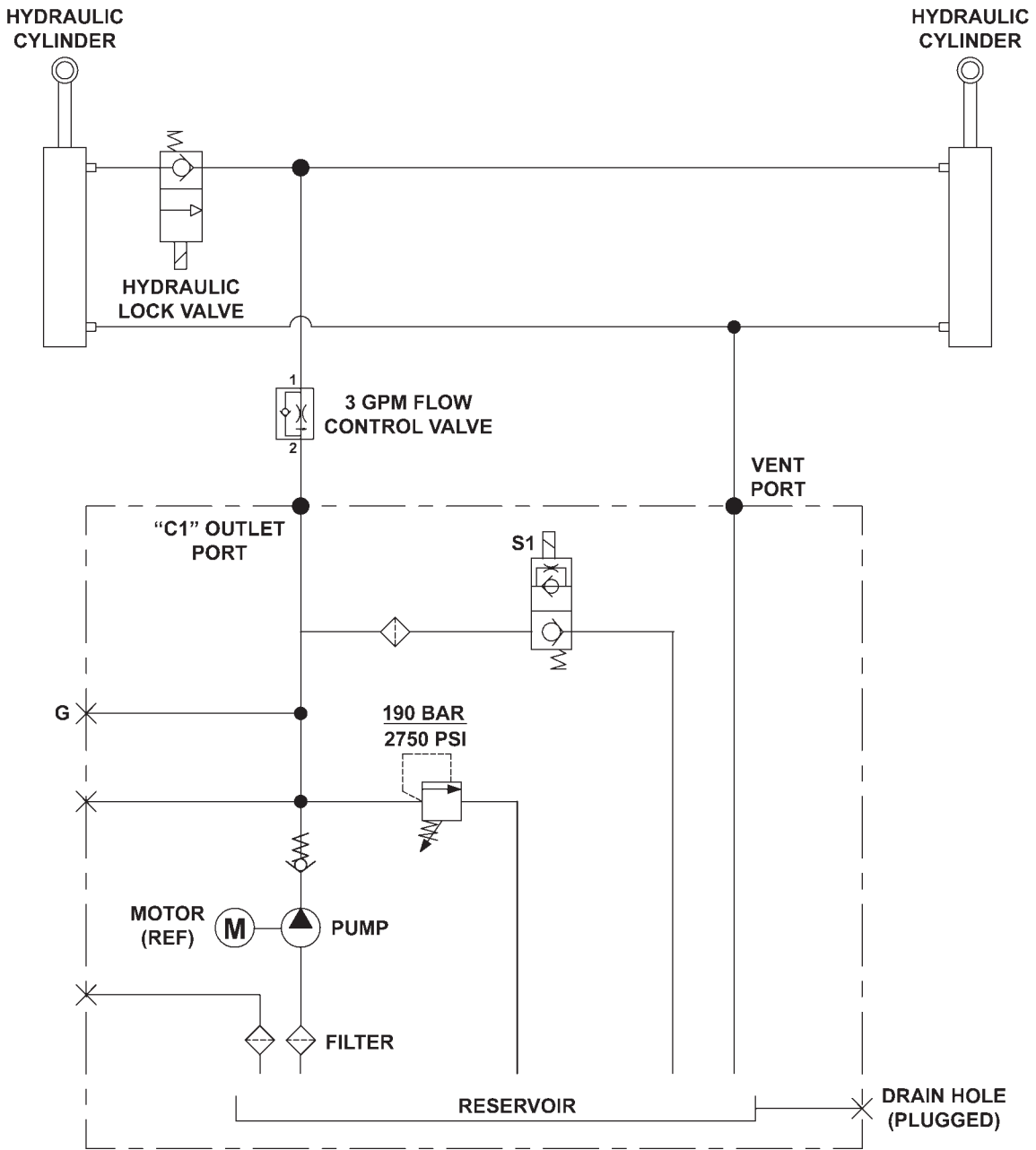

FIG. 69-1

SYSTEM DIAGRAMS - Continued

ELECTRICAL SCHEMATIC WITH MAX ECU MODULE (GRAVITY DOWN)

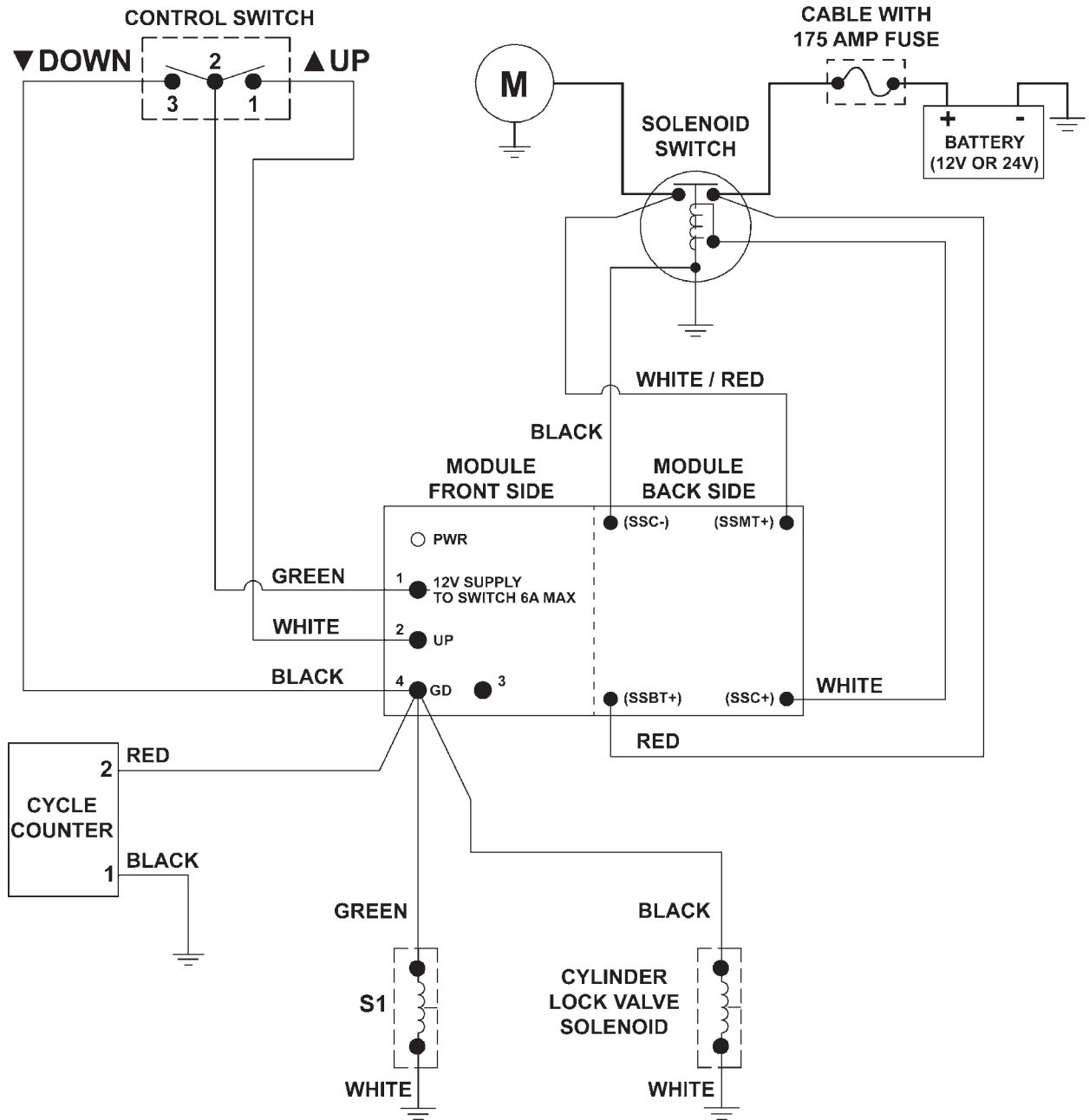
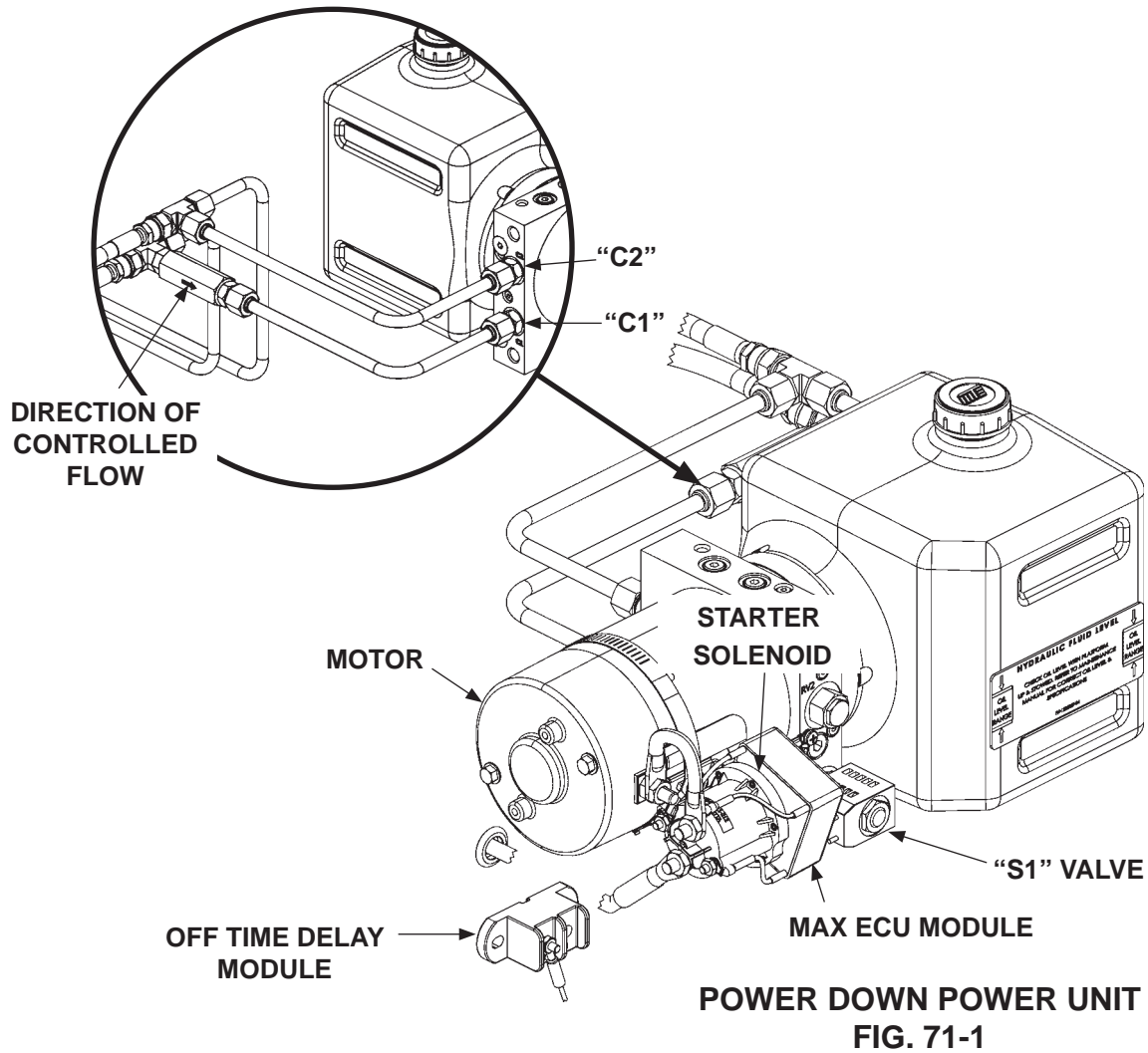

FIG. 70-1

SYSTEM DIAGRAMS - Continued

PUMP & MOTOR SOLENOID OPERATION WITH MAX ECU MODULE (POWER DOWN)



POWER UNIT MOTOR & SOLENOID OPERATION						
LIFTGATE FUNCTION	PORT	SOLENOID OPERATION (✓ MEANS ENERGIZED)				
		MOTOR(S)	VALVE "S1"	LH LOCK VALVE	RH LOCK VALVE	OFF TIME DELAY MODULE
RAISE	C1	✓	-	-	-	-
LOWER	C2	✓	✓	✓	✓	✓

REFER TO VALVES SHOWN ON
HYDRAULIC SCHEMATIC

TABLE 71-1

SYSTEM DIAGRAMS - Continued

HYDRAULIC SCHEMATIC WITH MAX ECU MODULE (POWER DOWN)

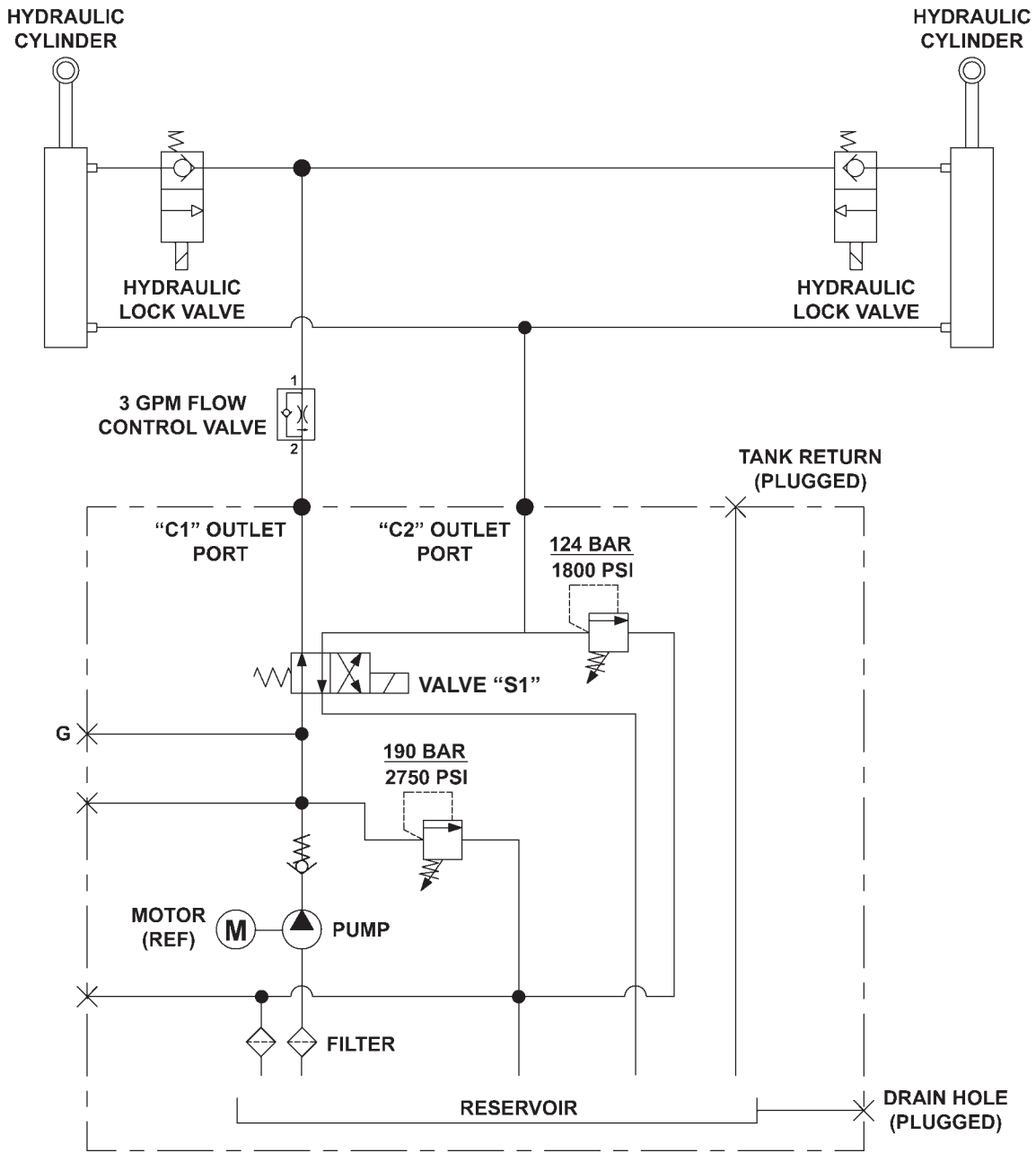

FIG. 72-1

SYSTEM DIAGRAMS - Continued

ELECTRICAL SCHEMATIC WITH MAX ECU MODULE (POWER DOWN)

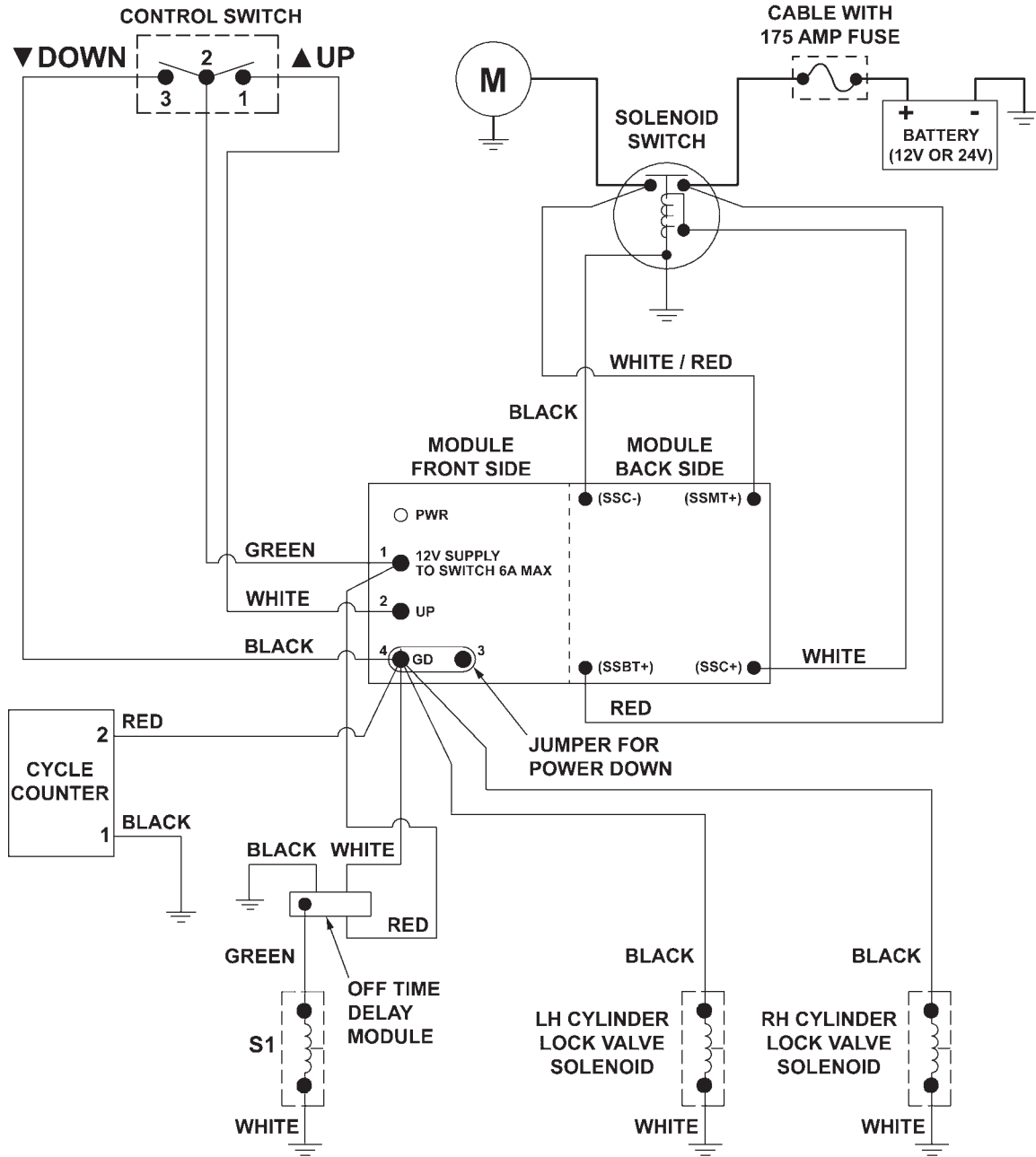

FIG. 73-1

SYSTEM DIAGRAMS - Continued

ELECTRICAL VALUES & TORQUE SPECIFICATIONS

Solenoid Switch	12V	24V
Coil resistance:	5.4Ω @70°F. ±15%	20.1Ω @70°F. ±15%
Ampere:	2.2A	1.2A
Coil terminal torque: 10-15 lb-in max.		
Contact terminal torque: 30-35 lb-in max.		
Solenoid Valve (S1)		
Coil resistance:	6.2Ω @ 70°F. ±15%	35.8Ω @ 70°F. ±15%
Ampere:	1.6A	0.67A
Coil terminal torque: 15-45 lb-in max.		
Valve cartridge torque: 25-30 lb-ft max.		
Coil nut torque: 15-45 lb-in		
Solenoid Lock Valve		
Coil resistance:	8.0Ω @ 70°F. ±15%	30Ω @ 70°F. ±15%
Ampere:	1.5A	0.8A
Coil nut torque: 3-4.5 lb-ft max.		
Valve cartridge torque: 18.5-22 lb-ft max.		
Digital Cycle Counter		
Operation voltage	4V - 30V	4V - 30V
Ampere	<2mA	
Ground Cable		
Cap screw torque: 24 lb-ft max.		

TABLE 74-1

OPTIONS OPTIONAL LIFTGATE COMPONENTS

MECHANICAL KITS	PART NO.	GD	PD
EXTENSION KIT 102", 13" EXTENSION PLATE, GALVANIZED	287095-03G	X	X
ELECTRICAL KITS			
PART NO.	GD	PD	
IN CAB ON-OFF SWITCH	298905-01	X	X
TUK-A-WAY DUAL CONTROL KIT	297115-01	X	X
TUK-A-WAY DUAL CONTROL KIT, STREET SIDE	297116-01	X	X
HAND HELD CONTROL ASSEMBLY, INSIDE	280570-07	X	
HAND HELD CONTROL ASSEMBLY, 120" LG.	263260-13	X	X
HAND HELD CONTROL ASSEMBLY, 240" LG.	263260-14	X	X
OVAL, 2 LIGHT MOUNTING FRAME BRACKET, GALVANIZED	282372-01G	X	X
CYCLE COUNTER	297620-01	X	X
MISCELLANEOUS KITS			
PART NO.	GD	PD	
TRAFFIC CONES	268893-01	X	X
EXTENSION PLATE HARDWARE KIT (96" & 102" W VEH)	283257-02	X	X
LICENSE PLATE, TUK-A-WAY	299970-01	X	X
LICENSE PLATE, WITHOUT LIGHT, TUK-A-WAY	299970-02	X	X
STEP OPTIONS (42" TO 46" BED HEIGHT, 30" OVERALL STEP HEIGHT)			
GALVANIZED DUAL STEP KITS WITH BUMPER			
PART NO.	GD	PD	
DUAL STEPS, 14" RUBBER BUMPERS	288705-01G	X	X
DUAL STEPS, 13.5" RUBBER BUMPERS	288705-02G	X	X
DUAL FLEX STEPS 14" RBR BUMPERS WITH FLEXIBLE WIRE ROPE LOWER STEP & 14" LG. RUBBER BUMPER	288705-21G	X	X
DUAL FLEX STEPS WITH FLEXIBLE WIRE ROPE LOWER STEP & 13.5" LG. RUBBER BUMPER	288705-22G	X	X
DUAL STEPS W/ BRACKET FOR LIGHT AND 14" RUBBER BUMPERS	288705-31G	X	X
DUAL STEPS W/ BRACKET FOR LIGHT AND 13.5" PLASTIC BUMPERS	288705-32G	X	X
GALVANIZED DUAL STEPS WITH BUMPERS AND NO STEPS ON STREET SIDE			
PART NO.	GD	PD	
DUAL STEPS, STREET SIDE, NO STEPS, 14" BUMPER	288705-03G	X	X
DUAL STEPS, STREET SIDE, NO STEPS, 13.5" BUMPER	288705-04G	X	X
DUAL FLEX STEPS, STREET SIDE, NO STEPS, 14" BUMPER	288705-23G	X	X
DUAL FLEX STEPS, STREET SIDE, NO STEPS, 13.5" BUMPER	288705-24G	X	X
DUAL STEPS, W/LIGHT STREET SIDE, NO STEPS, 14" BUMPER	288705-33G	X	X
DUAL STEPS, W/LIGHT STREET SIDE, NO STEPS, 13.5" BUMPER	288705-34G	X	X
GALVANIZED DUAL STEPS WITHOUT BUMPERS			
PART NO.	GD	PD	
DUAL STEPS, NO BUMPERS	288705-05G	X	X
DUAL STEPS, STREET SIDE, NO STEPS, NO BUMPERS	288705-06G	X	X
DUAL FLEX STEPS, NO BUMPERS	288705-25G	X	X
DUAL FLEX STEPS, STREET SIDE, NO STEPS, NO BUMPERS	288705-26G	X	X
DUAL STEPS W/LIGHT, NO BUMPERS	288705-35G	X	X
DUAL STEPS W/LIGHT, STREET SIDE, NO STEPS, NO BUMPER	288705-36G	X	X

MAXON[®] 11921 Slauson Ave. Santa Fe Springs, CA. 90670 (800) 227-4116 FAX (888) 771-7713

OPTIONS

OPTIONAL LIFTGATE COMPONENTS - CONTINUED

STEP OPTIONS (38" TO 42" BED HEIGHT, 21" OVERALL STEP HEIGHT)			
GALVANIZED SINGLE STEPS WITH BUMPERS	PART NO.	GD	PD
SINGLE STEPS, 14" RUBBER BUMPERS	288705-11G	X	X
SINGLE STEPS, 13.5" PLASTIC BUMPERS	288705-12G	X	X
GALVANIZED SINGLE STEPS WITH BUMPERS NO STEPS ON STREET SIDE	PART NO.	GD	PD
SINGLE STEPS, STREET SIDE NO STEPS, 14" RUBBER BUMPERS	288705-13G	X	X
SINGLE STEPS, STREET SIDE NO STEPS, 13.5" PE BUMPERS	288705-14G	X	X
GALVANIZED SINGLE STEPS WITHOUT BUMPERS	PART NO.	GD	PD
SINGLE STEP KIT, NO BUMPERS	288705-15G	X	X
SINGLE STEP KIT, STREET SIDE, NO STEPS, NO BUMPERS	288705-16G	X	X
GALVANIZED DUAL STEPS WITH BUMPERS & LIGHT CUTOUTS	PART NO.	GD	PD
DUAL STEPS W/LIGHT, 14" RUBBER BUMPERS	288705-41G	X	X
DUAL STEPS W/LIGHT, 13.5" PLASTIC BUMPERS	288705-42G	X	X
GALVANIZED DUAL STEPS WITH BUMPERS & LIGHT CUTOUTS	PART NO.	GD	PD
DUAL STEPS W/LIGHT, SS NO STEPS, 14" RUBBER BUMPERS	288705-43G	X	X
DUAL STEPS W/LIGHT, SS NO STEPS, 13.5" PLASTIC BUMPERS	288705-44G	X	X
GALVANIZED DUAL STEPS WITHOUT BUMPERS & LIGHT CUTOUTS	PART NO.	GD	PD
DUAL STEPS W/LIGHT, NO BUMPERS	288705-45G	X	X
DUAL STEPS W/LIGHT, NO BUMPERS	288705-46G	X	X
BUMPERS KIT	PART NO.	GD	PD
RUBBER BUMPER KIT, 14" BUMPERS (2.5"W X 3"H X 14" LG)	288706-01	X	X
RUBBER BUMPER KIT, 13.5" PLASTIC BUMPERS (2.9"W X 1.5"H X 13.5" LG)	288707-01	X	X

MAXON® 11921 Slauson Ave. Santa Fe Springs, CA. 90670 (800) 227-4116 FAX (888) 771-7713

MAXON®

PRE-DELIVERY INSPECTION FORM

Important! This pre-delivery checklist is to aid the installer in confirming the proper installation of this Maxon product. It is not a comprehensive list and does not replace the use of the installation manual. The installer is responsible for following all instructions in the installation manual.

Model: _____

Date: _____

Serial Number: _____

Technician: _____

Pre-Installation Inspection:

- Correct model
- Correct capacity
- Correct platform size
- Correct options
- Correct manuals & decals

Structural Inspection:

- Liftgate is centered on vehicle rear door & mounted per dimensions in this manual.
- Pump box is mounted securely.
- All installation welds are done per instructions in this manual.
- All roll pins, bolts & fasteners on liftgate are tight.
- All hardware & fasteners, used to secure liftgate to vehicle body, are tight.
- Ensure platform ramp touches ground when shackles are 1" above ground, and platform & flipover are level & touching the ground.

Hydraulic Inspection:

- Fluid is at correct level (See **CHECKING HYDRAULIC FLUID** step in this manual.)
- No leaks from hydraulic fittings in pump box
- No leaks from hydraulic line connections

Electrical Inspection:

- Power/charge plug and terminals are clean & tight
- Individual wire connections are tight
- Circuit breaker (150A) is installed in battery box (if equipped) or by truck/tractor battery.
- Batteries are fully charged, all cable connections are tight & tie-downs are tight.
- Solenoid wiring connections are tight.
- Wiring harness connections are tight.
- Electrical cable connections are tight & secured clear of moving parts & sharp edges.

Operation Inspection:

NOTE: The following times are for 46" bed height, aluminum platform and flipover, Exxon Univis HVI-13 hydraulic fluid, & temperature at 70°F. Times are for reference only and may vary for larger platforms, smaller platforms, or temperature changes.

- Liftgate operates correctly using all main & optional control switches.

MXT-25 or MXT-33 Gravity Down only:

- Unloaded platform lowers in **9 sec.**
- Unloaded platform raises in **10 sec.**

MXT-25 or MXT-33 Power Down only:

- Unloaded platform lowers in **9 sec.**
- Unloaded platform raises in **11 sec.**

MXT-25 or MXT-33:

- Unloaded platform raises and lowers evenly. At the extension plate, platform must not be more than **1/4"** uneven, from side to side.
- Acceptable breakaway force to unfold platform and fold platform is **40 lb-ft** maximum.
- Platform stores securely under vehicle body
- Cycle counter indicates total number of up and down cycles and adds 1 more count each time platform is raised and lowered.
- Decals in correct location and legible

Verify all lights are operational (For lights supplied by MAXON only)

- Platform lights turn **ON** when platform is unfolded, and turn **OFF** when platform is stowed.
- Taillights, stop lights, turn lights, and backup lights turn **ON** and **OFF** correctly.