

TUK-A-WAY® SERIES

The MXT-25 & MXT-33 Series

MAXON®

Launch in
February 2021

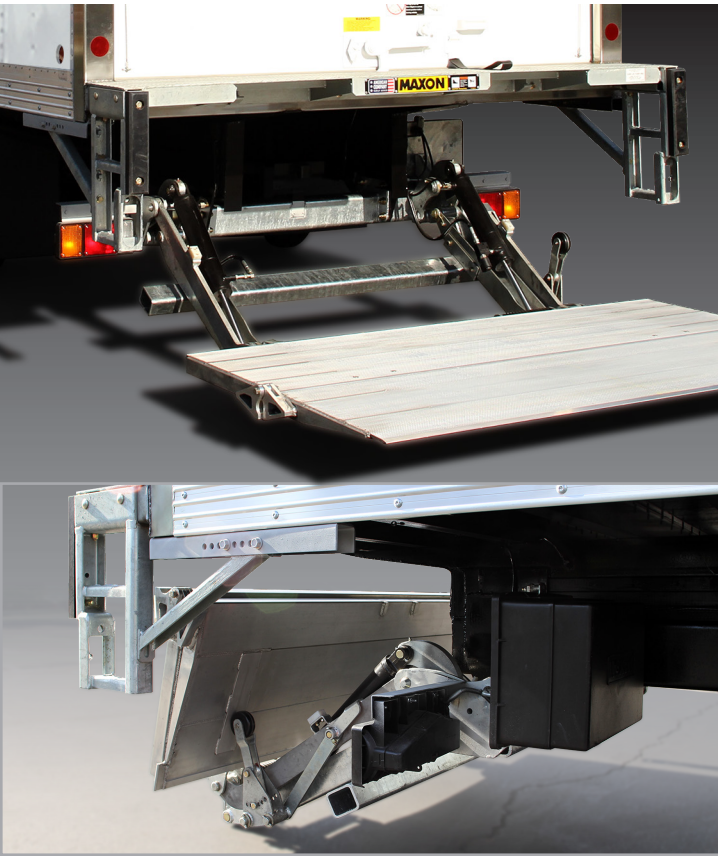

MXT-25 & MXT-33 SPECIFICATIONS

MAXON's MXT-25 & MXT-33 liftgate models combine low bedheight application with a premium level-ramping ride feature

- Level-ramping ride platform travel pattern
- Steel, Steel/Aluminum as well as all Aluminum platforms
- Bolt-on extension plate and steps
- Hydraulic locking
- Grease fittings at all critical rotation points
- All steel components come hot-dip galvanized **STANDARD!**

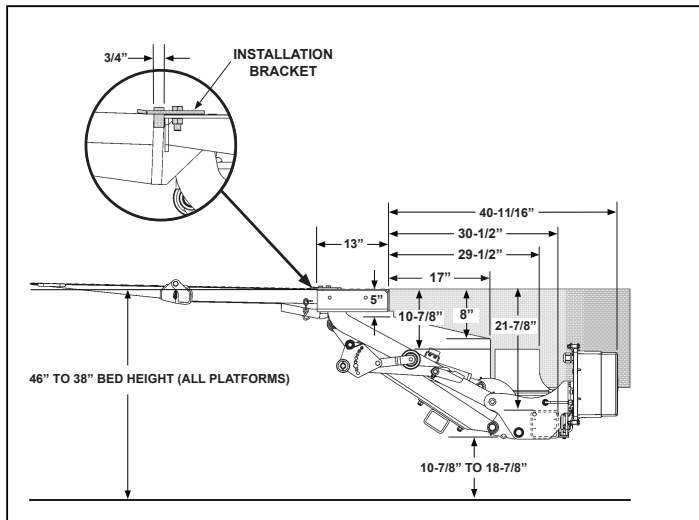

Lift Dimensions and Mounting Requirements
Refer to install manual for MXT-25 & MXT-33

MODEL	CAPACITY	PLATFORM SIZE	TOTAL WEIGHT	BED HEIGHT
MXT-25	2,500 Lbs.	80" x 48" (24+24)	990 Lbs - ST/ST	38" Min. Laden
MXT-33	3,300 Lbs.		945 Lbs - ST/AL 900 Lbs - AL/AL	46" Max. Unladen

"ST" - Steel
"AL" - Aluminum

NOTE: Please review appropriate liftgate installation manual for full vehicle and or body requirements to ensure proper fitment.



TUK-A-WAY® SERIES

The MXT-25 & MXT-33 Series

MAXON®

Standard Features

- Level-ramping ride
- Galvanized steel components
- MAX GRIP® AL platform surface treatment
- Cycle counter
- Dual cylinder hydraulic system
- Lock valve for automatic stowing

Optional Features

- Hand held control
- Dual controls
- Cab Cut-off switch
- MAX ECU (Electrical Control Unit)
- Power down
- Dual Cart stops
- Multiple step options
- License plate mount kit
- 24 Volt configuration

Loadable Platform Space with Cart Stops Deployed

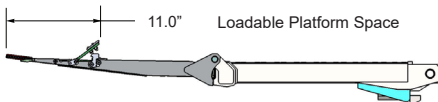

Distributed by:

M-258-0121

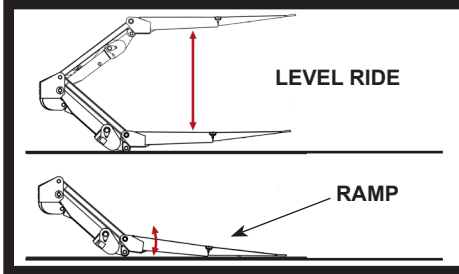

Level-Ramping Ride Platform

The MXT features a premium level-ramping ride pattern. It is equipped with a brand new knuckling mechanism that works in gravity mode.

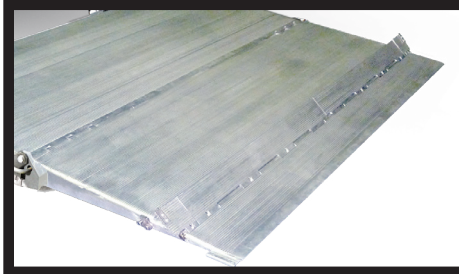

Wedge-Type Platform Design

The MXT features a 48" x 80" wedge-type steel, steel/aluminum, or aluminum/aluminum platform. The ST/AL and AL/AL platforms come optional with dual cart stops. The wedge design allows smooth transition of load on and off the platform.



Twin Cylinder Design

The MXT features a twin cylinder, mid-arm design resulting in great performance and stability.

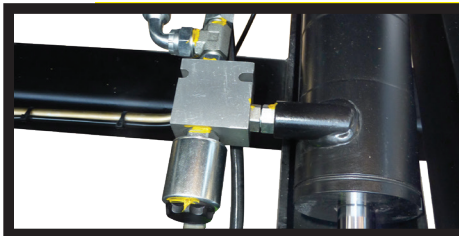

Hydraulic Locking

The MXT features a hydraulic lock valve that takes operator involvement out of the equation. As soon as the control button is released the hydraulic system is always securely locked.



Bolt-On Steps & Extension Plate

The steps and extension plates were strategically designed to bolt-on in order to avoid welding on the gate that would affect the factory paint. The steps were also designed as an integral part of the gate that would easily allow for them to be exchanged in case of dock damage.



Fully Galvanized - STANDARD

Galvanization is the process by which zinc is coated over corrosive (easily rusted) metals. The process of galvanizing not only protects from corrosion of various 'soft metals' but also adds strength to the original, uncoated metal