

M-90-2
REV. D
JANUARY 2021

MAXON®

OPERATION MANUAL

↑ **RAILIFT®**
↓ **LIFTGATE SERIES**

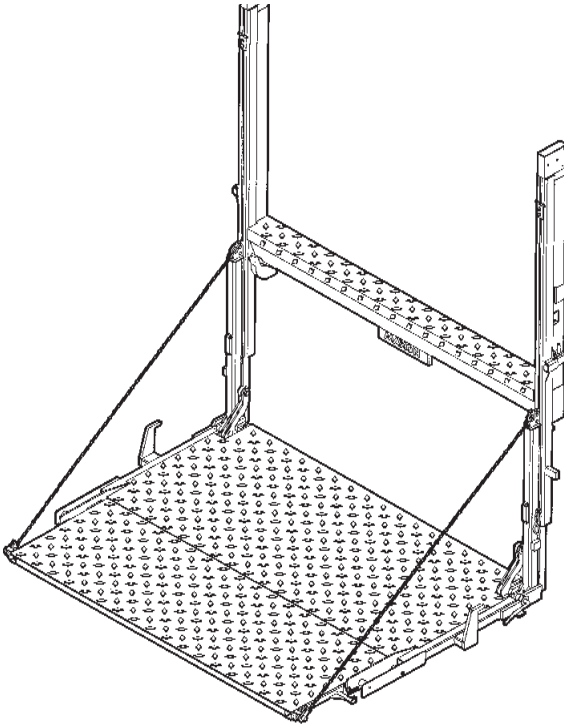

RC-2B

RC-3B

RC-4B

RC-5B

RC-6B

RC-6K

To find maintenance information for your **RC Liftgate**, go to www.maxonlift.com. Click the **PRODUCTS, RAILIFT & RC** buttons. Open the **Maintenance Manual** in the **PRODUCT DOCUMENTATION** window. For parts, click on the **PARTS PORTAL, RAILIFT & RC** buttons.

© MAXON Lift Corp. 2021

KEEP THIS MANUAL IN CAB OF VEHICLE

Register your liftgate on line at www.maxonlift.com/htm/services/reg.htm. For a free copy of other manuals that pertain to this model Liftgate, please visit our website at www.maxonlift.com or **customer service at (800) 227-4116**.

TABLE OF CONTENTS

SUMMARY OF CHANGES: M-90-2, REVISION D	4
WARNINGS	5
RECOMMENDED DAILY OPERATION CHECKS	6
LIFTGATE TERMINOLOGY	8
DECALS AND PLATES	9
FORKLIFT ADVISORY	11
OPERATION	12
STANDARD CONTROLS	12
UNLOADING VEHICLE	16
RAISING PLATFORM	16
POSITIONING LOAD	18
LOWERING & UNLOADING PLATFORM	19
LOADING VEHICLE	20
UNFOLDING RETENTION RAMP (IF EQUIPPED)	20
POSITIONING LOAD	21
RAISING & UNLOADING PLATFORM	22
STOWING PLATFORM	24
STOW RETENTION RAMP (IF EQUIPPED)	24
FOLDING & RAISING PLATFORM	25
DOCK LOADING & UNLOADING	27
LOWER PLATFORM BELOW DOCK LEVEL	27

SUMMARY OF CHANGES: M-90-2, REVISION D

PAGE	DESCRIPTION OF CHANGE
All	Converted to folded booklet layout suitable for storing in glovebox of vehicle.
COVER	Updated REV, graphics and date of release.
6,7	Inserted pages with RECOMMENDED DAILY OPERATION CHECKS .
8	Inserted page with LIFTGATE TERMINOLOGY .
12-13	Inserted descriptions of liftgate controls.
14-28	Updated instructions about the use of liftgate to unload and load a vehicle, and loading/unloading from a dock without using the liftgate.
18-21	Updated WARNINGS with consequences of placing too much of a load on the outer folding section of the platform.

WARNING

1. Incorrect operation of this Liftgate can result in serious personal injury. Comply with **WARNINGS** and Liftgate operating instructions in this manual. Do not allow untrained persons to operate the Liftgate. If you need to replace an **Operation Manual**, additional copies are available from:

MAXON Lift Corp. Customer Service
11921 Slauson Ave
Santa Fe Springs, CA 90670
(800) 227-4116

2. Do not exceed rated **load capacity** of the Liftgates which is **2,000 lbs. for model RC-2B, 3,000 lbs. for model RC-3B, 4,000 lbs. for model RC-4B, 5,000 lbs. for model RC-5B, and 6,000 lbs. for models RC-6B and RC-6K.**
3. Do not allow any part of your body to be placed under, within, or around any portion of the moving Liftgate or its mechanisms, or in a position that would trap them between the platform and the floor of truck body (or between platform and the ground) when Liftgate is operated.
4. Consider the safety and location of bystanders and location of nearby objects when operating the Liftgate. Stand to one side of platform while operating the Liftgate. Be certain that the area the Liftgate will move through during operation is clear of all obstacles.
5. Comply with all attached instruction decals and warning decals.
6. Keep decals clean and legible. If decals are illegible or missing, have them replaced. **Get free replacement decals from Maxon.**
7. **Never drive a forklift on the Liftgate platform.**
8. Do not move vehicle unless Liftgate is correctly stowed.
9. **Correctly stow platform when not in use. Extended platforms could create a hazard for people and vehicles passing by.**
10. A correctly installed Liftgate will operate smoothly and reasonably quiet. The only noticeable noise, during Liftgate operation, is from the power unit while the platform is being opened (SD models only), lowered (power down models only), raised, or closed. Listen for scraping, grating and binding noises and have the problem corrected before continuing to operate the Liftgate.
11. Above all, **USE GOOD COMMON SENSE** when operating this Liftgate.
12. Never use a cell phone while operating the Liftgate.

RECOMMENDED DAILY OPERATION CHECKS

NOTE: Before you check the Liftgate, park vehicle on flat ground and set the parking brake.

NOTE: If any of the following operation checks reveal a need to service or repair Liftgate, do not operate the Liftgate until a qualified mechanic services or repairs the Liftgate.

Before operating the Liftgate, the operator should do the following:

- Make sure batteries are fully charged, battery terminal connections are clean and tight, and battery box is undamaged.
- Make sure cab cutoff switch is **ON**, if equipped.
- Visually check that main frame housing cover is bolted on securely and undamaged. Look for hydraulic fluid leaks from main frame and columns.
- Follow the visible routing of hydraulic hoses from cylinders to main frame housing . Make sure all hoses are connected at both ends and there are no cracks, chafing, and fluid leaks.
- Visually check that standard and optional controls are in place and undamaged.
- Visually check that all decals are in place (see **DECALS** page). Make sure decals are legible, clean, and undamaged.

Use the operation instructions in this manual to unfold the platform and lower it to the ground.

- Check for smooth operation as platform unfolds and as runners lower the platform to the ground.
- Check main frame, columns, runners and platform openers for cracks and bends. Make sure platform chains are undamaged and connected securely at both ends. Also, make sure all bolts and pins are in place and undamaged.
- Check platform and folding section for cracks, holes, and bends on the load-carrying surfaces and side plates. Also, make sure retention ramps (if equipped) are undamaged and operate smoothly.
- Make sure load-carrying surfaces on platform, folding section, and retention ramp (if equipped) are clean (no oil, debris, or corrosion).
- Check for fluid leaks from hydraulic cylinders.

Use the operation instructions in this manual to operate the Liftgate through one cycle without a load on the platform. Raise the platform to vehicle bed height. Next, lower the platform to ground level.

- When raising and lowering platform, listen for unusual noises and look for a “jerking” motion or uneven movement at LH and RH sides of the platform. Uneven movement should not exceed 1”.
- With platform at bed height, make sure the LH and RH platform chains feel even in tightness.
- Retention ramps (if equipped) release, unfold and fold smoothly, and remain in ramp, retention, and stowed positions until intentionally moved.

If service or repairs are not required (or if completed), stow platform for transport.

LIFTGATE TERMINOLOGY

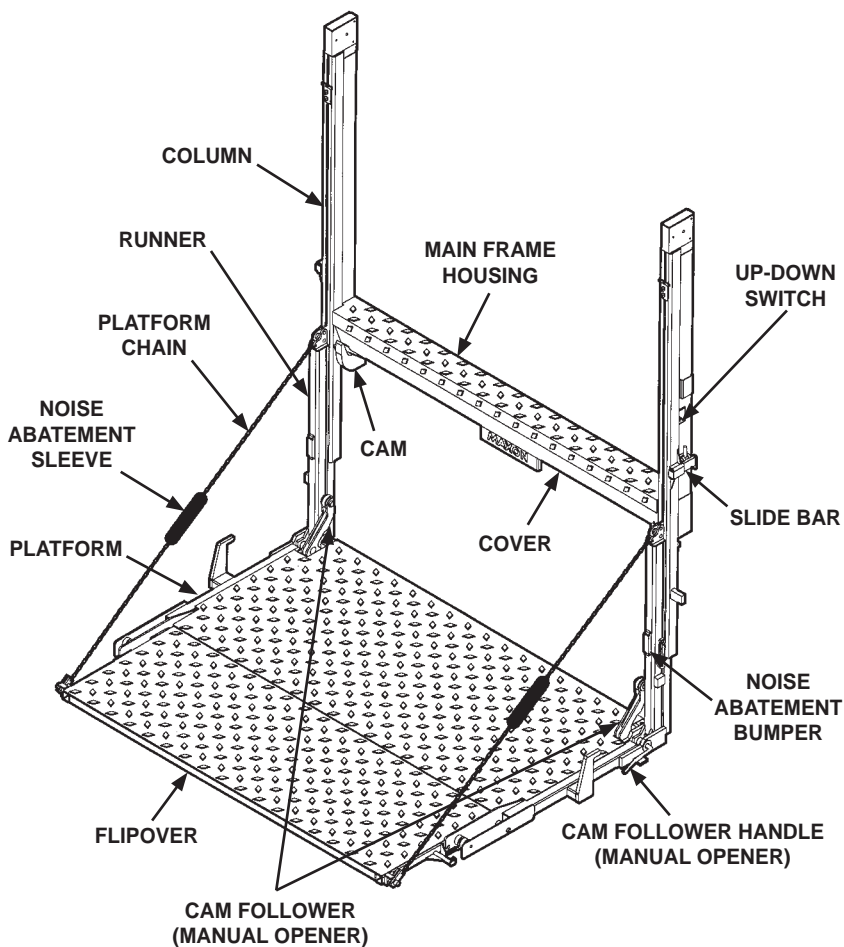

RC WITH MANUAL CLOSER

FIG. 8-1

DECALS AND PLATES

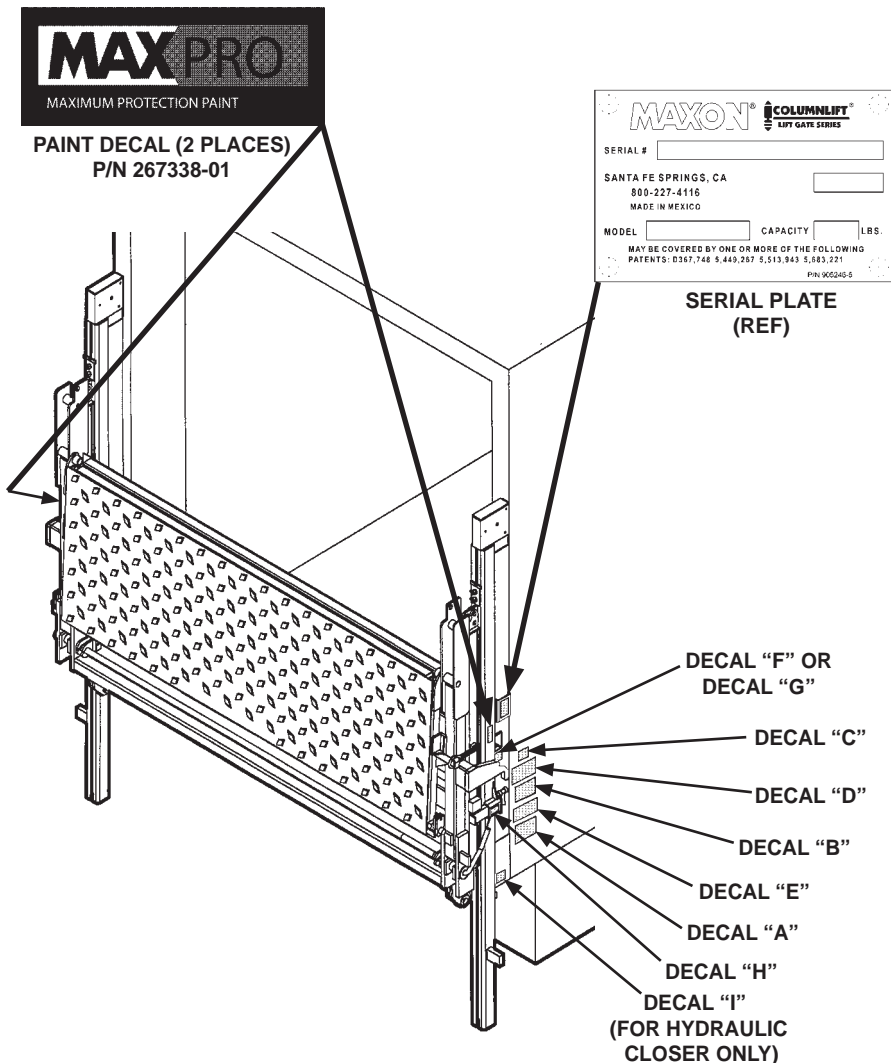

DECALS AND PLATES - Continued

SAFETY INSTRUCTIONS

Read all decals and operation manual before operating liftgate.

1. Do not use liftgate unless you have been properly instructed and have read, and are familiar with, the operating instructions.
2. Be certain vehicle is properly and securely braked before using the liftgate.
3. Always inspect this liftgate for maintenance or damage before using it. Do not use liftgate if it shows any sign of damage or improper maintenance.
4. Do not overload.
5. Make certain the area in which the platform will open and close is clear before opening or closing the platform.
6. Make certain platform area, including the area in which loads may fall from platform, is clear before and at all times during operation of liftgate.
7. This liftgate is intended for loading and unloading of cargo only. Do not use this liftgate for anything but its intended use.

(A)

WARNING

Read this information carefully.

- Improper operation of this Liftgate can result in serious personal injury. If you do not have a copy of the operating instructions, please obtain them from your employer, distributor, or lessor before you attempt to operate Liftgate.
- If there are signs of improper maintenance, damage to vital parts, or slippery platform surface, do not use the Liftgate until these problems have been corrected.
- If you are using a pallet jack, be sure it can be maneuvered safely.
- Do not operate a forklift on the platform.
- Do not allow any part of yours or your helper's body to be placed under, within, or around any portion of the moving Liftgate, or its mechanisms, or in a position that would trap them between the platform and the ground or truck when the Liftgate is operated.
- If a helper is riding the platform with you, make sure you are both doing so safely and that you are not in danger of coming in contact with any moving or potentially moving obstacles.
- **USE GOOD COMMON SENSE**
- If load appears to be unsafe, do not lift or lower it.

For a free copy of other manuals that pertain to this model Liftgate, please visit our website at www.mxnlift.com or call Customer Service at (800) 227-4116.

(B)

THE MAXIMUM CAPACITY
OF THIS LIFT IS

_____ POUNDS

WHEN THE LOAD IS
CENTERED ON THE LOAD
CARRYING PLATFORM

(C)

(See TABLES 10-1 & 10-2)



WARNING

Liftgate hazards can result
in crushing or falling.

Keep hands and feet clear of
pinch points.

If riding liftgate, make sure load
is stable and footing is solid.

(D)

Read and understand all instructions and WARNINGS before use.

CAUTION

Always stand clear
of platform area.

P/N 268356-01 (E)

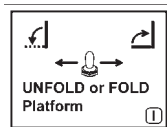
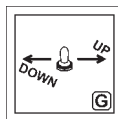
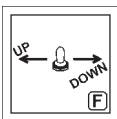

DECAL SHEET
FIG. 10-1

MODEL	ORDER P/N
RC-2 CAM OPENER	268385-01
RC-3 CAM OPENER	268385-02
RC-4 CAM OPENER	268385-03
RC-5 CAM OPENER	268385-04
RC-6 CAM OPENER	268385-05

MODEL	ORDER P/N
RC-2 HYD OPENER	268386-01
RC-3 HYD OPENER	268386-02
RC-4 HYD OPENER	268386-03
RC-5 HYD OPENER	268386-04
RC-6 HYD OPENER	268386-05

DECAL SHEET PART NUMBERS
TABLE 10-1

DECAL SHEET PART NUMBERS
TABLE 10-2

FORKLIFT ADVISORY

⚠ WARNING
Keep forklift OFF of platform.

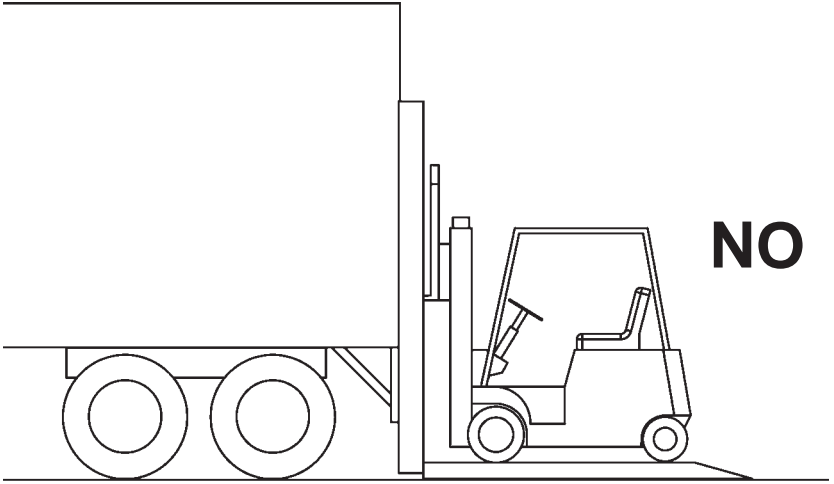

FIG. 11-1

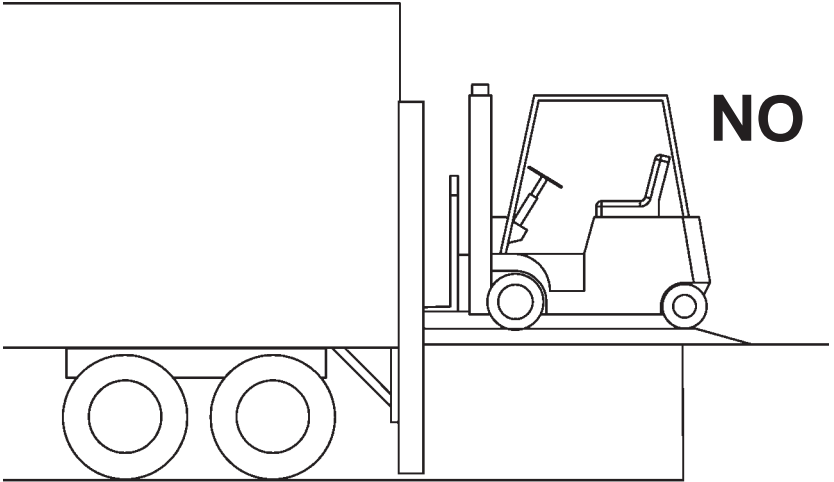

FIG. 11-2

OPERATION

STANDARD CONTROLS

GROUND ACCESS TO UP-DOWN SWITCH

Toggle switch on the RH column (FIG. 12-1A) lets operator raise (UP) and lower (DOWN) the platform (FIG. 12-1) while standing on the ground.

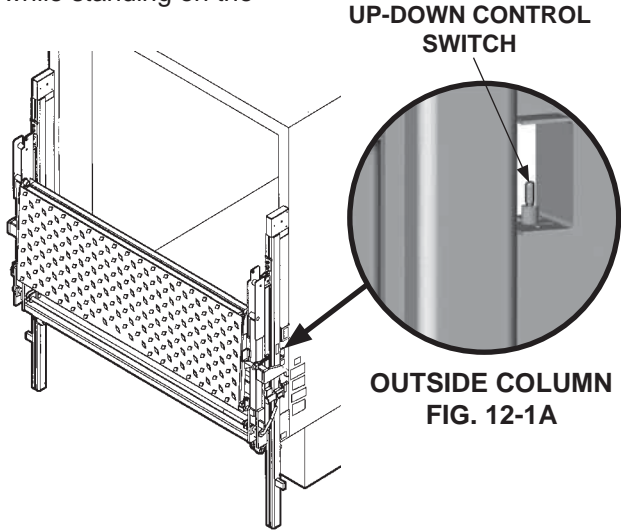

FIG. 12-1

PLATFORM ACCESS TO UP-DOWN SWITCH

Toggle switch (FIG. 12-1B) on RH column lets operator raise (UP) and lower (DOWN) the platform (FIG. 12-1) while standing on the platform.

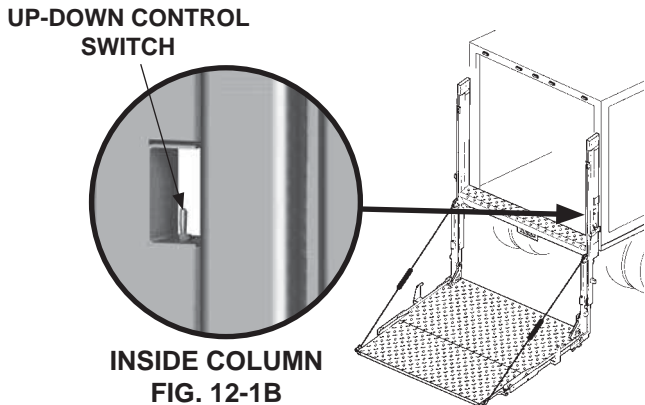

FIG. 12-2

NOTE: The platform on Liftgate with cam open and close automatically unfolds as it lowers to the ground. Handle is used to fold platform while it is being raised to stowed position.

CAM FOLLOWER HANDLE (CAM OPEN & CLOSE ONLY)

The cam follower, and handle on the RH side of the platform (**FIG. 13-2A**) lets operator fold the platform (**FIG. 13-1**) while standing on the ground.

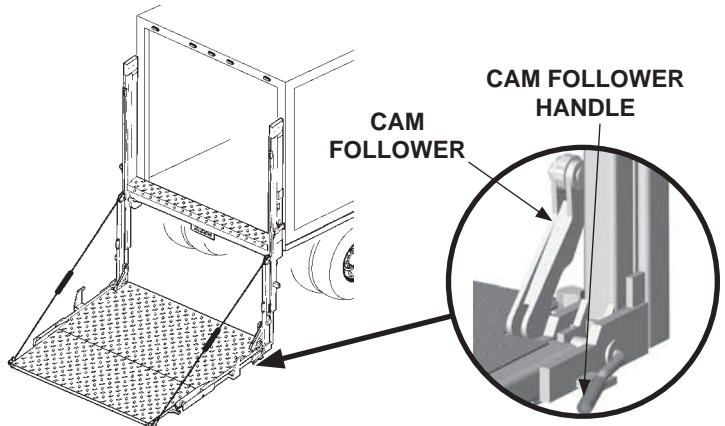

FIG. 13-2

FIG. 13-2A

FOLD-UNFOLD SWITCH (HYDRAULIC OPEN & CLOSE ONLY)

The **FOLD-UNFOLD** switch at bottom of the RH column (**FIG. 13-1A**) lets operator **UNFOLD** and **FOLD** the platform (**FIG. 13-1**) while standing on the ground.

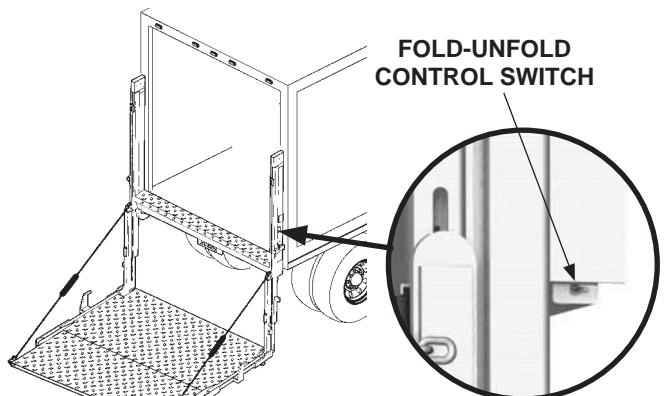

FIG. 13-1

FIG. 13-1A

UNFOLDING & LOWERING PLATFORM

WARNING

Ensure no people or objects are in the path of the platform when unfolding. Serious personal injury and property damage can result from being struck by platform.

1. Use **UP-DOWN** switch on curbside column to raise (**UP**) the runners off the stop block. Next, disconnect platform holding chain from platform (**FIG. 14-1**). Then, raise stop and move slide bar on column away from stop block on runner (**FIG. 14-1**). This keeps slide bar clear of stop block when lowering platform.

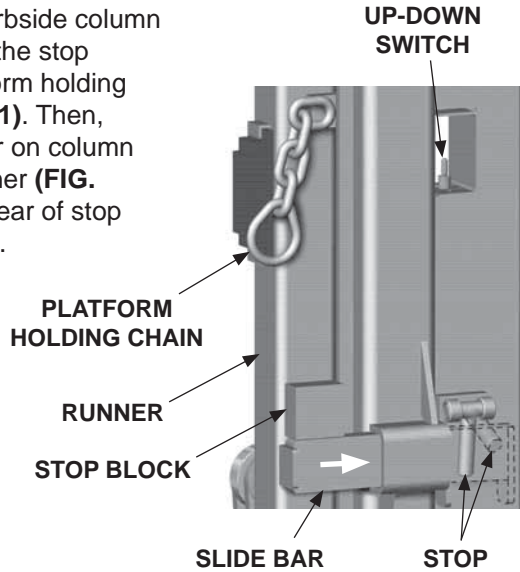

FIG. 14-1

CAM OPEN & CLOSE

2. Use **UP-DOWN** switch (**FIG. 14-1**) to lower the platform to the ground (**FIG. 14-2**). Platform unfolds as it lowers.

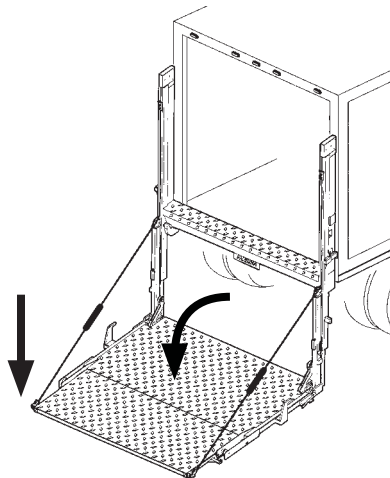

FIG. 14-2

RCT PLATFORM

3. Use handle to unhook platform (**FIG. 15-1**). Continue with step 4 to unfold platform.

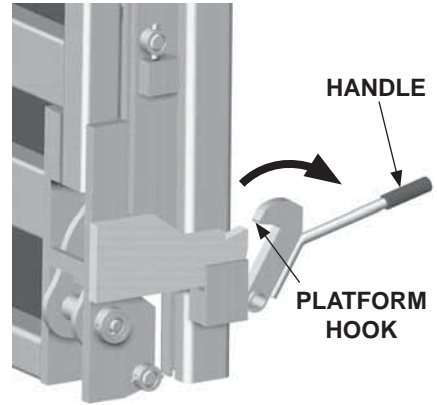

FIG. 15-1

HYDRAULIC OPEN & CLOSE

4. Use **FOLD-UNFOLD** switch (**FIG. 15-2**) near bottom of column to unfold platform. Then, use **UP-DOWN** switch (**FIG. 14-1**) to lower the platform to the ground (**FIG. 14-2**).

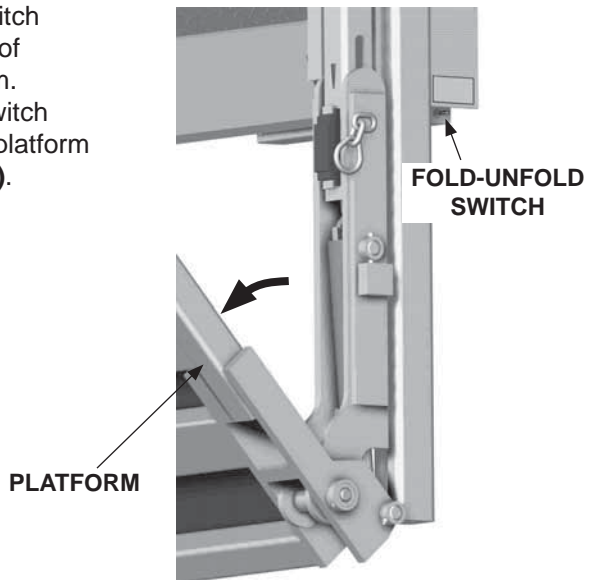

FIG. 15-1

UNLOADING VEHICLE RAISING PLATFORM

⚠ CAUTION

A ramp in retention position can trip you when stepping over it. To prevent possible injury, get on the platform before putting the ramp in retention position.

1. Release retention ramp (if equipped) from stowed position by rotating latch off plate on curbside and streetside of the ramp (FIGS. 16-1 and 16-1A).

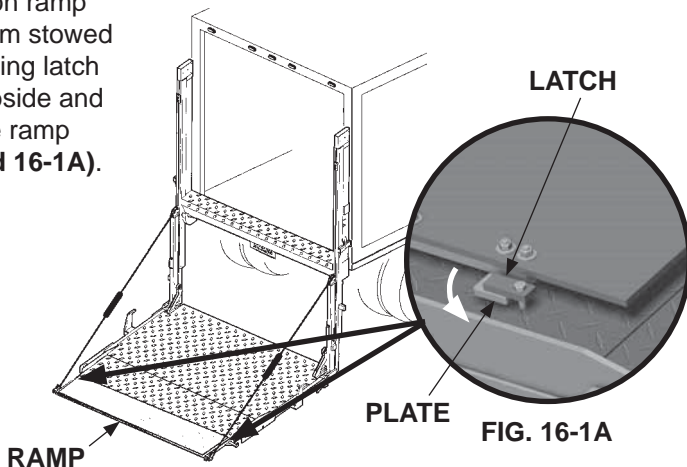

FIG. 16-1

2. Stand on the platform to lift retention ramp up to retention position and fasten in place (FIGS. 16-2 and 16-2A). Then, stand in the operator area shown by footprints in FIG. 16-2.

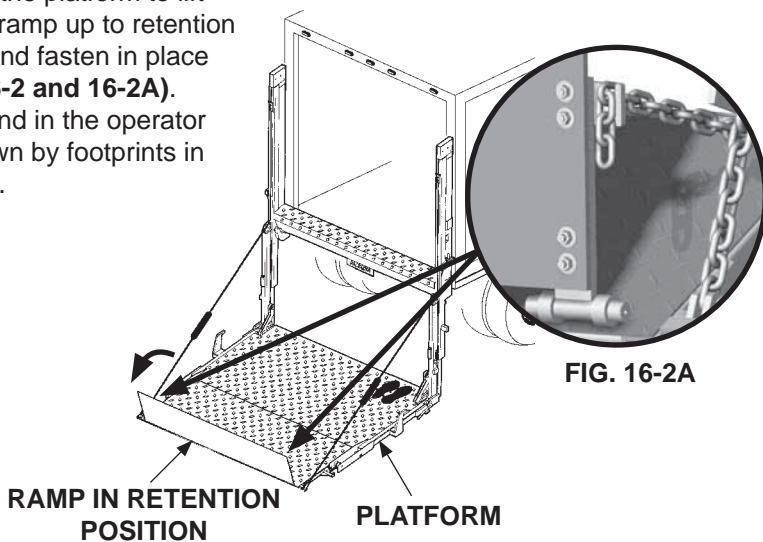
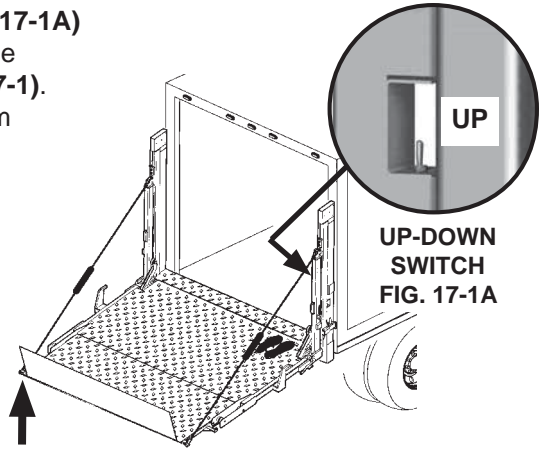

FIG. 16-2

3. Use **UP-DOWN** switch (**FIG. 17-1A**) to raise (**UP**) platform from the ground to bed height (**FIG. 17-1**). Release switch when platform reaches bed height.



RAISING PLATFORM
FIG. 17-1

POSITIONING LOAD

WARNING

A load should never extend past the edges of the platform, and the greatest portion of the load must rest on the main section of the platform. Do not place unstable loads on platform and do not allow load to exceed lifting capacity of Liftgate. If standing on platform, do not allow your feet to extend beyond inboard edge of platform. If most of a load is on the outer folding section of platform, it can cause platform to start folding and dumping operator and load off the platform. Serious bodily harm and property damage could result.

Place all loads as close as possible to the inboard edge of the platform with heaviest part toward the inboard edge as shown in **FIG. 18-1**. Comply with the preceding **WARNING**. If standing on platform with the load, stand in the footprint area shown and comply with the preceding **WARNING**.

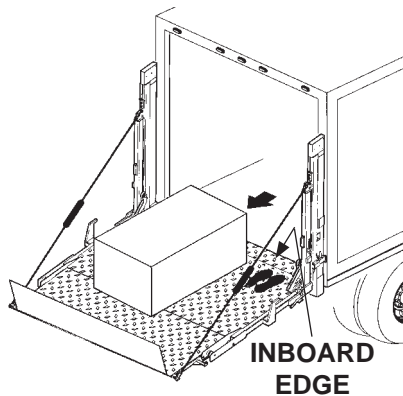

MOVING LOAD ON PLATFORM
FIG. 18-1

LOWERING & UNLOADING PLATFORM

1. Use **UP-DOWN** switch (**FIG. 19-1A**) to lower (**DOWN**) platform to the ground (**FIG. 19-1**).

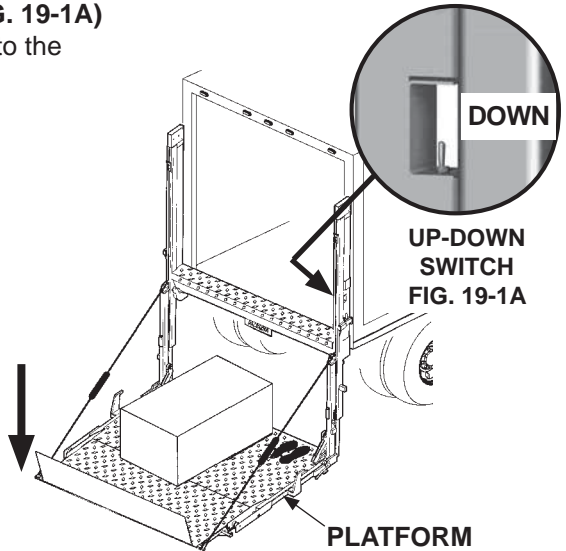

LOWERING PLATFORM AND LOAD
FIG. 19-1

2. Unfold retention ramp to ramp position (**FIG. 19-2**).

3. Carefully move the load off the platform and clear of the work area (**FIG. 19-2**).

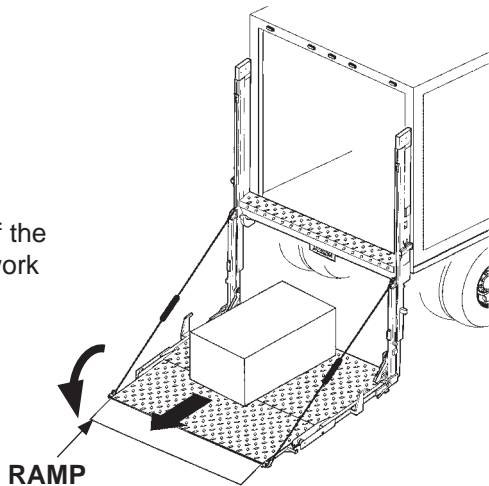

UNLOADING PLATFORM
FIG. 19-2

4. If there are more loads to unload from vehicle, repeat the previous **UNLOADING VEHICLE** steps for each load. When unloading and loading are finished, use **STOWING PLATFORM** procedure in this manual.

LOADING VEHICLE UNFOLDING RETENTION RAMP (IF EQUIPPED)

1. Release retention ramp from stowed position by rotating both latches off the plate on curbside and streetside of the ramp (FIGS. 20-1 and 20-1A).

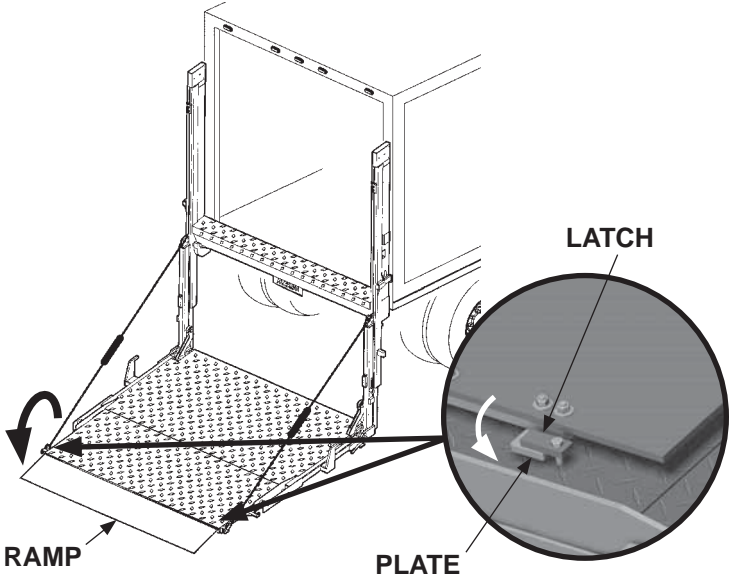

FIG. 20-1

FIG. 20-1A

2. Unfold retention ramp to ramp position (FIG. 20-1).

POSITIONING LOAD

WARNING

A load should never extend past the edges of the platform, and the greatest portion of the load must rest on the main section of the platform. Do not place unstable loads on platform and do not allow load to exceed lifting capacity of Liftgate. If standing on platform, do not allow your feet to extend beyond inboard edge of platform. If most of a load is on the outer folding section of platform, it can cause platform to start folding and dumping operator and load off the platform. Serious bodily harm and property damage could result.

WARNING

Liftgates equipped with manual platform close have a cam follower mechanism to fold platform. Before lifting a load to bed height, ensure the cam follower is disengaged to prevent platform from folding near bed height. Cam follower in close position can cause platform to start folding. Folding platform could dump operator and load off the platform resulting in serious bodily harm and property damage.

Place all loads as close as possible to the inboard edge of the platform with heaviest part toward the inboard edge as shown in **FIG. 21-1**. Comply with the preceding **WARNINGS**. Move loads across the ramp (**FIG. 21-1**) to the platform, but never rest or raise loads on the ramp. If standing on platform with the load, stand in the footprint area shown and comply with the preceding **WARNING**.

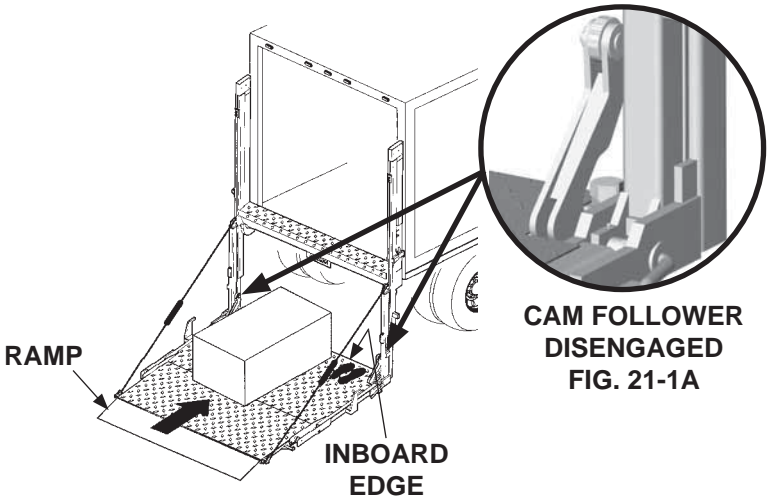

LOADING PLATFORM AT GROUND LEVEL

FIG. 21-1

LOADING VEHICLE - Continued RAISING & UNLOADING PLATFORM

CAUTION

A ramp in retention position can trip you when stepping over it. To prevent possible injury, get on the platform before putting the ramp in retention position.

1. Stand on the platform to rotate retention ramp up (if equipped) and fasten in retention position (FIGS. 22-1 and 22-1A). Then, stand in the operator area shown by footprints in FIG. 22-1.

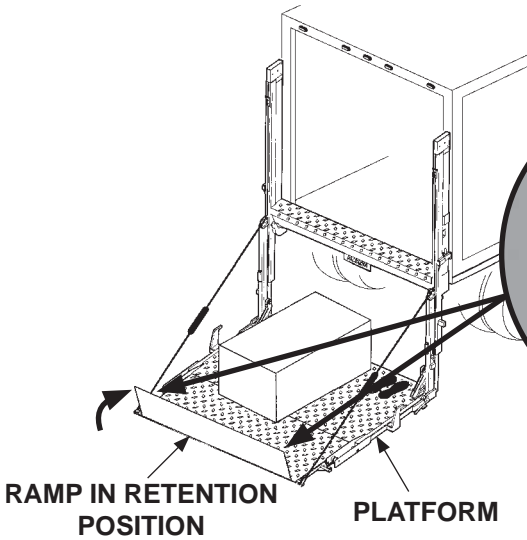

FIG. 22-1

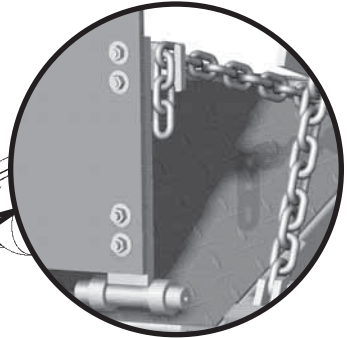
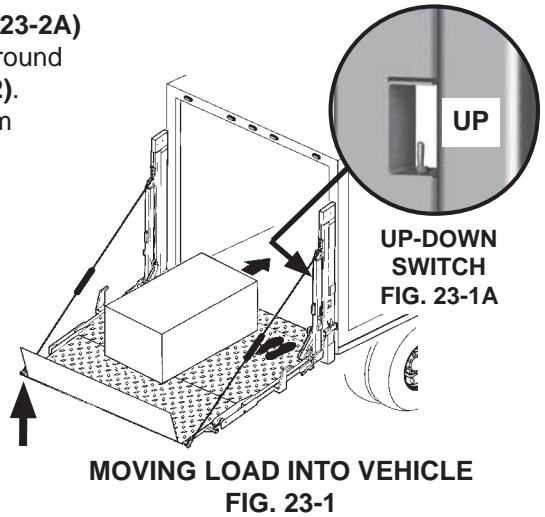

FIG. 22-1A

2. Use **UP-DOWN** switch (**FIG. 23-2A**) to raise (**UP**) platform from ground level to bed height (**FIG. 23-2**). Release switch when platform reaches bed height.

3. Carefully move the load into vehicle (**FIG. 23-1**).



4. Use **UP-DOWN** switch (**FIG. 23-2A**) to lower (**DOWN**) platform to ground level (**FIG. 23-2**).

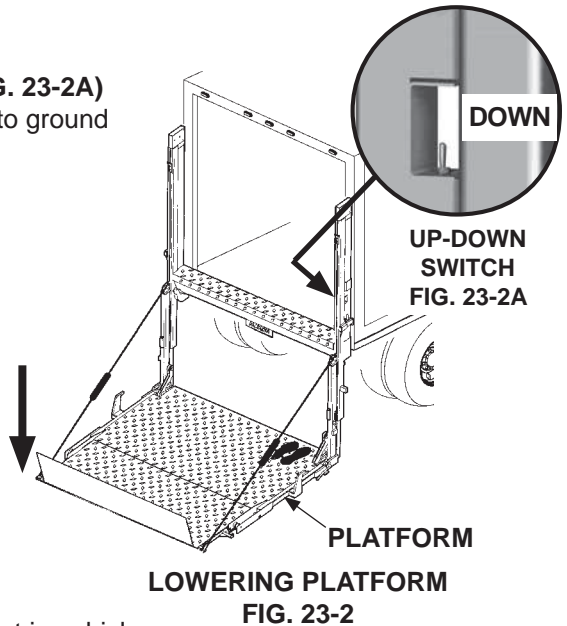

5. If there are more loads to put in vehicle, repeat the previous **LOADING VEHICLE** steps for each load. When loading is finished, use **STOWING PLATFORM** procedure in this manual.

STOWING PLATFORM

STOW RETENTION RAMP (IF EQUIPPED)

1. Fold retention ramp to stowed position (FIG. 24-1).

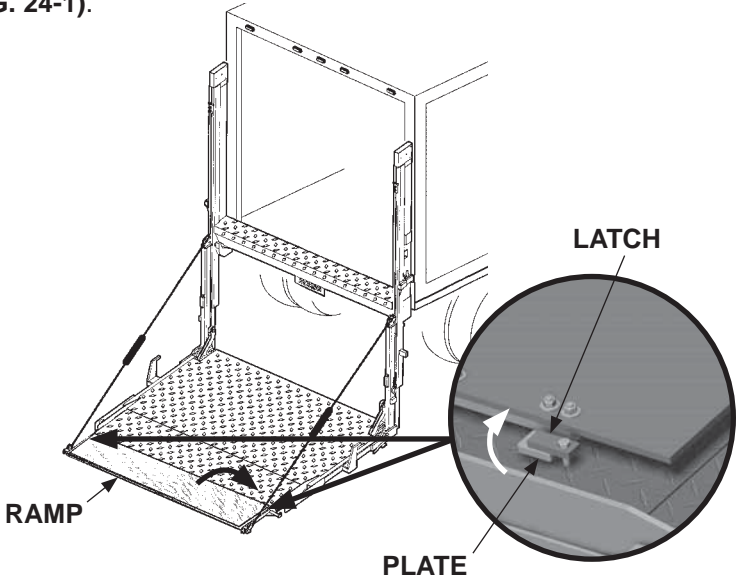

FIG. 24-1

FIG. 24-1A

2. Secure retention ramp on platform by rotating each latch over plate on curbside and streetside of the ramp (FIGS. 24-1 and 24-1A).

FOLDING & RAISING PLATFORM

WARNING

Ensure no people or objects are in the path of the platform when folding. Serious personal injury and property damage can result from being struck by platform.

1. Ensure the slide bar is clear from the path of the runner (FIG. 25-1). Then, use **UP-DOWN** control switch on curbside column to raise (**UP**) the platform.

CAM OPEN & CLOSE

2. Use **UP-DOWN** control switch (FIG. 25-1) to raise (**UP**) platform to cams on bottom of the main frame housing (FIG. 25-2). Continue to hold switch in the **UP** position. Next, pull up on the cam follower handle (FIG. 25-2A) to engage the cam followers with cams under the housing. As cam followers engage the cams, release handle as platform begins to fold (FIG. 25-2). Allow platform to fold against bumper on runner and runners raise to stops. Then, release the **UP-DOWN** switch (FIG. 25-1).

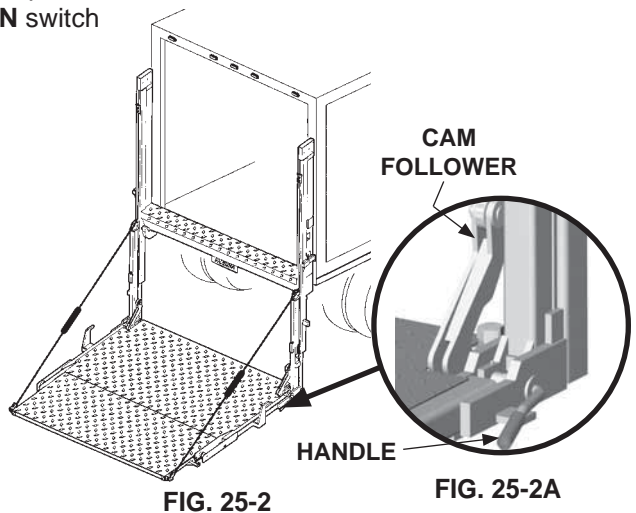

HYDRAULIC OPEN & CLOSE

3. Use **FOLD-UNFOLD** switch (**FIG. 26-1**) near the bottom of column. Then, use **UP-DOWN** control switch (**FIG. 27-1**) to raise runners to the stops.

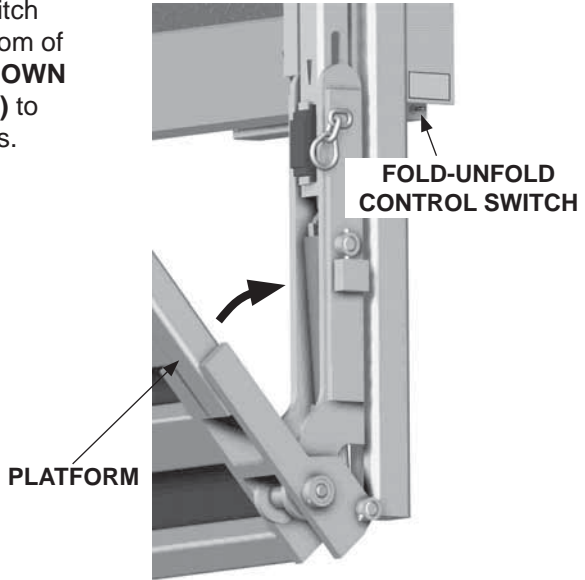

FIG. 26-1

4. Connect platform holding chain to folded platform (**FIG. 26-2A**). Next move slide bar under stop block on runner (**FIG. 26-2A**). Liftgate is ready for transport.

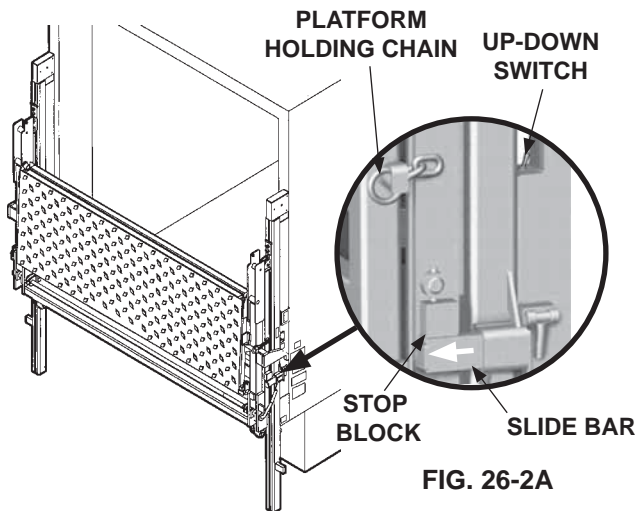

FIG. 26-2A

FIG. 26-2

DOCK LOADING & UNLOADING LOWER PLATFORM BELOW DOCK LEVEL

⚠ CAUTION

Use dock plate for moving loads between dock and vehicle. Dock plate must be supported by dock and vehicle floor. Placing dock plate on platform of the Liftgate could result in personal injury and property damage when moving loads across the plate.

NOTE: This procedure is only for RC Liftgates. RCT Liftgates are ready for dock loading with platform stowed. Platform is lower than floor of the vehicle body. The stowed platform on RC liftgates must be lowered below floor of vehicle body.

1. Use **UP-DOWN** switch on curbside column (**FIG. 27-1**) to raise (**UP**) the runners off the stop block. Then, lift stop and move slide bar away from stop block on runner (**FIG. 27-1**). This will keep slide bar clear of stop block when lowering platform.
2. Use **UP-DOWN** switch on column (**FIG. 27-2A**) to lower (**DOWN**) platform below floor level of vehicle body (**FIG. 27-2**). Then, release switch when folded platform is below floor level. Loads can now be moved between dock and vehicle floor using a dock plate.

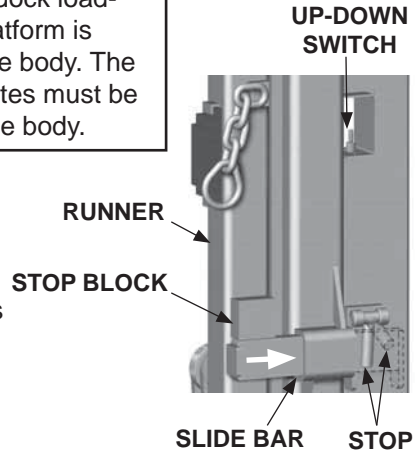
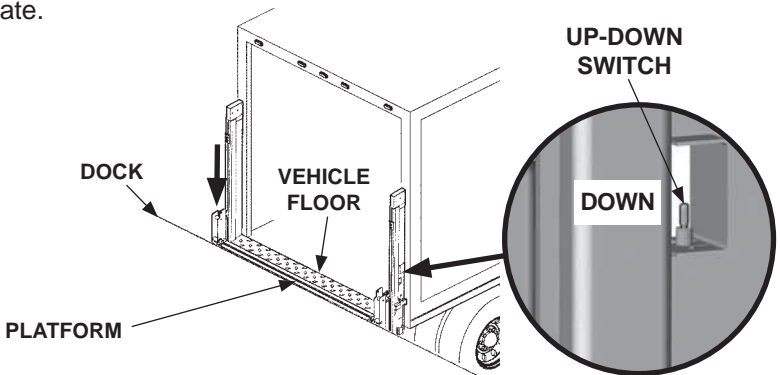

FIG. 27-1



PLATFORM LOWERED TO
DOCK LOADING POSITION

OUTSIDE COLUMN
FIG. 27-2A

FIG. 27-2

⚠ WARNING

Platform must be stowed, platform holder chain connected and slide bar engaged before moving vehicle. Serious injury and property damage could result if platform is unfolded while vehicle is moving.

3. When finished loading and unloading from the dock, use **UP-DOWN** switch to raise (**UP**) platform to the stops (**FIGS. 28-1 and 28-1A**).

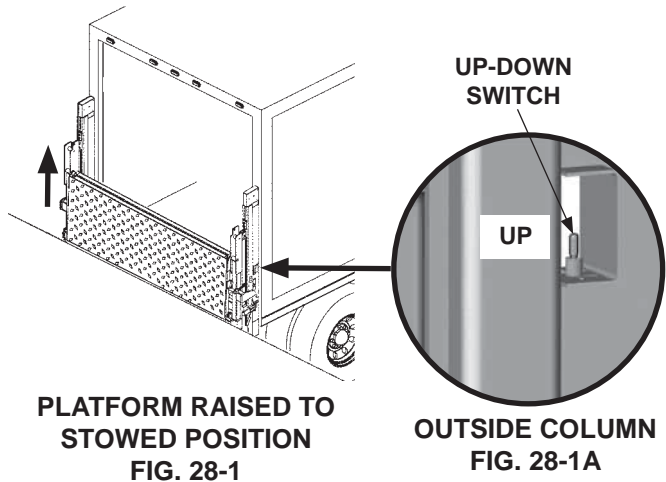

4. Connect platform holding chain to folded platform (**FIG. 28-2**). Next move slide bar under stop block on runner (**FIG. 28-2**). Liftgate is ready for transport.

